

PI33xx-xx-EVAL1 Cool-Power® ZVS Buck Regulator Evaluation Board



Contents	Page
Introduction	1
Evaluation Board Supply & Load Connections	2
Bill of Materials	3
Evaluation Board Notes	4
Optional Test Points & Component Locations	4
Board Dimensions	4
PCB Metal Layers	4

Introduction

The PI33xx-xx-EVAL1 evaluation board demonstrates the features and benefits of the Picor Cool-Power® ZVS Buck Regulator PI33XX family. The board features the ZVS Buck Regulator SIP (U1), along with inductor (L1), ceramic input (C1-C8), and output capacitors (C10-C16).

The evaluation board provides several options for making input power (Vin and GND) and output load (Vout and GND) connections. The user can solder tab style banana jacks or wire, use threaded binding posts secured by a retaining nut, or to simply use a #6 nut and bolt connection.

All the I/O pins are labeled and routed to the board edge for easy access. Each I/O pin is accompanied with an adjacent 50 mil through-hole for adding a test point or to facilitate wiring to external circuitry.

The board has a scope tip jack for measuring output voltage (Vout), and has locations for two optional jacks for measuring Vin and the switching node of the regulator (See Figure 4). There are two headers installed: an ENABLE jumper which can be used to enable or disable the converter and the remote sense jumper (H1) that will connect the buck's remote sense pin to the output at the Vout terminal.

Figure 1.
PI33xx-xx-EVAL1
Evaluation Board*

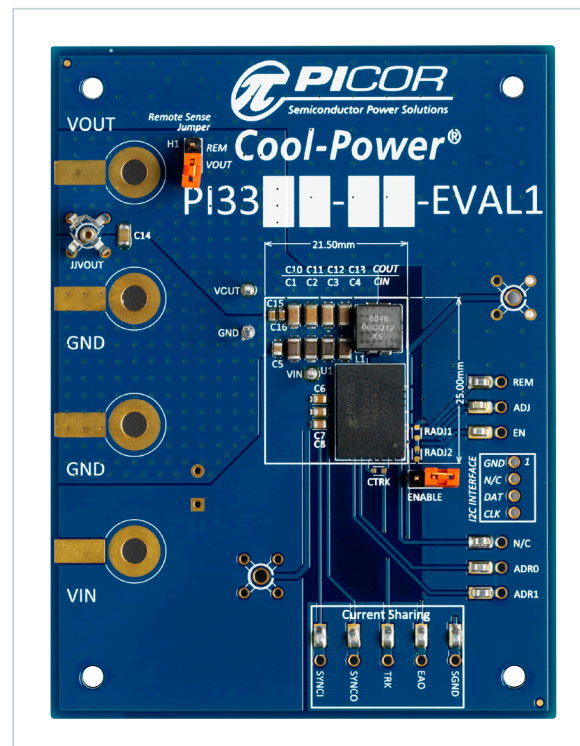

* RSYNCL resistor not shown

Introduction (Cont.)

For PI33XX-20 regulators only, there is a location for a 4-pin I²C header that allows users to set certain device parameters and to read the fault registers of the regulator. Each regulator can be assigned an address from 0 to 7 using the two tri-state address pins (ADR0 and ADR1).

Connections required for parallel regulator operation are grouped together (labeled Current Sharing) to allow for easy connection between evaluation boards. There is a zero ohm jumper between SYNCI and SGND to ensure that SYNCI is grounded when not used for paralleling PI33XX regulators. This resistor must be removed for parallel operation.

There are two unpopulated resistor footprints (RADJ1 and RADJ2) used in trimming the output voltage and a capacitor footprint (CTRK) to add additional capacitance to the output tracking pin. Please refer to the product datasheet for more detailed information on these topics.

The evaluation board is constructed using 4 layers of 2 oz copper and is routed to optimize the regulation path between input and output voltage, which reduces the parasitic losses and yields the best efficiency.

Evaluation Board Supply & Load Connections

Figure 2 displays the recommended connections for input supply and output loading, and the best test points for measuring input and output voltages. All the I/O pins are brought out to the edge to allow for easy measurement and/or connection to the user's external circuitry.

Figure 2.
Evaluation Board
Measurement
Connection

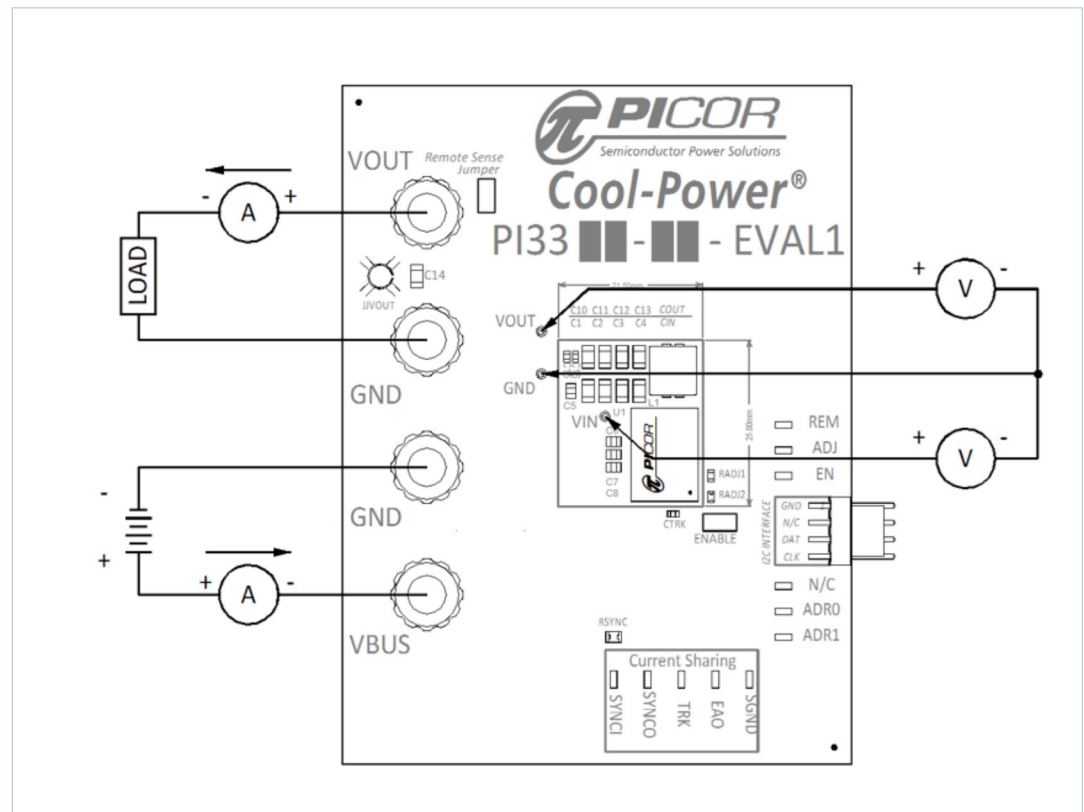
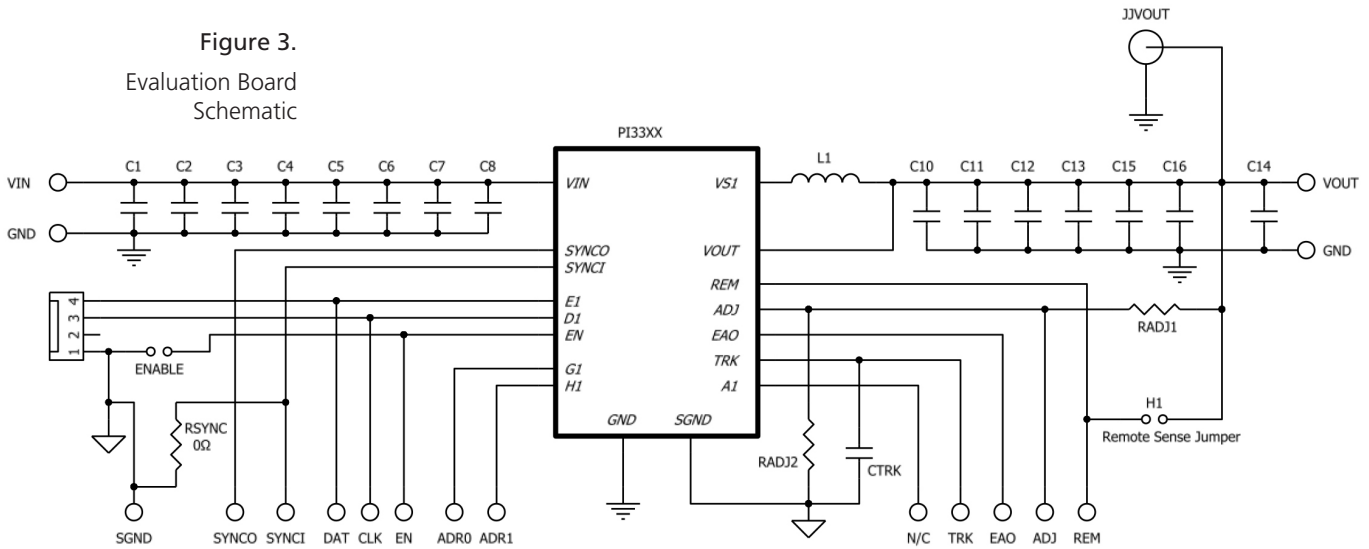

Figure 3.
Evaluation Board
Schematic



Bill of Materials

Table 1.
Bill of Material
Picor Cool-Power®
ZVS Buck Regulator
Evaluation Board

Device	Qty	Designators	Value	Description	Manufacturer	Part Number
PI3312	1	U1	2.5 V ZVS Regulator	ZVS Regulator	PICOR	PI3312-00-LGIZ
	4	C10, C11 C12, C13	100 μ F 6 V	Ceramic Output Capacitor	Murata	GRM31CR60J107ME39L
	1	L1	200 nH	Buck Inductor	Cooper	FPT705-200-R
PI3301	1	U1	3.3 V ZVS Regulator	ZVS Regulator	PICOR	PI3301-00-LGIZ
	4	C10, C11 C12, C13	100 μ F 6V	Ceramic Output Capacitor	Murata	GRM31CR60J107ME39L
	1	L1	200 nH	Buck Inductor	Cooper	FPT705-200-R
PI3302	1	U1	5 V ZVS Regulator	ZVS Regulator	PICOR	PI3302-00-LGIZ
	4	C10, C11 C12, C13	47 μ F 16 V	Ceramic Output Capacitor	Murata	GRM31CR61A476ME15
	1	L1	200 nH	Buck Inductor	Cooper	FPT705-200-R
PI3303	1	U1	12 V ZVS Regulator	ZVS Regulator	PICOR	PI3303-00-LGIZ
	4	C10, C11 C12, C13	22 μ F 25 V	Ceramic Output Capacitor	Murata	GRM31CR61E226KE15L
	1	L1	230 nH	Buck Inductor	Cooper	FPT705-230-R
PI3305	1	U1	15 V ZVS Regulator	ZVS Regulator	PICOR	PI3305-00-LGIZ
	4	C10, C11 C12, C13	22 μ F 25 V	Ceramic Output Capacitor	Murata	GRM31CR61E226KE15L
	1	L1	230 nH	Buck Inductor	Cooper	FPT705-230-R

Bill of Materials (Cont.)

Table 1.
(Continued)

Device	Qty	Designators	Value	Description	Manufacturer	Part Number
Common	10	ADJ, ADR0 ADR1, EAO EN, REM SGND, SYNCI SYNCO, TRK		SM Testpoint	Keystone	5015
	4	C1, C2 C3, C4	4.7 μ F 50 V	Ceramic Capacitor 50 V, X7R	Murata	GRM31CR71H475KA12L
	4	C5, C6 C7, C8	0.1 μ F 50 V	Ceramic Capacitor	TDK	C2012X7R1H104K
	1	C14	0.1 μ F 50 V	Ceramic Capacitor	Murata	RM319R71H104KA01D
	2	C15, C16	1 μ F 50 V	Ceramic Capacitor	Murata	GRM188R71C105KA12J
	1	CTRK	47 nF	Ceramic Capacitor	Murata	GRM188F51H473ZA01D
	2	ENABLE H1		Header Jumper	Samtec	TSW-148-07-F-S
	3	GND, VIN VOUT		TH Testpoint	Vector	K24
	1	JJVOUT		Johnson Jack	Tektronix	131503100
	1	PCB		PI33XX-xx- EVAL1 PCB	PICOR	PCB0108
	1	RSYNCI	0 Ω	0603 Resistor	Rohm	MCR03EZPJ000
User Optional	2	RADJ1 RADJ2	User Defined	0603 Trim resistors	TBD	TBD
	2	JJVIN JJVSW	Optional	Scope Tip Jack	Tektronix	131503100

Evaluation Board Notes

The evaluation board has solder mask openings on the bottom side of the board to allow for the option of additional output capacitance (4 x 1206 or 2 x 1812).

There are two additional, unmarked, scope tip test points (circled in red in figure 4) that allow the user to measure VIN and the switching node (VS1). These are labeled as JJVIN and JJVSW in Figure 4.

There are two thru-hole pads (blue circle) for the addition of an electrolytic bulk storage capacitor. This capacitor is required when the evaluation board is connected to the input voltage source through long leads. A 100 μ F, 50 V Electrolytic is recommended with an ESR between 20 and 50 m Ω .

The two pins labeled as "N/C" (highlighted in green box in figure 4) are not electrically connected to each other.

There is an internal connection within the PI33xx between grounds SGND and PGND. It is not required to tie these two grounds together externally and these two grounds are not connected together on the evaluation board.

Figure 4.
Optional Test Points
& Component Locations

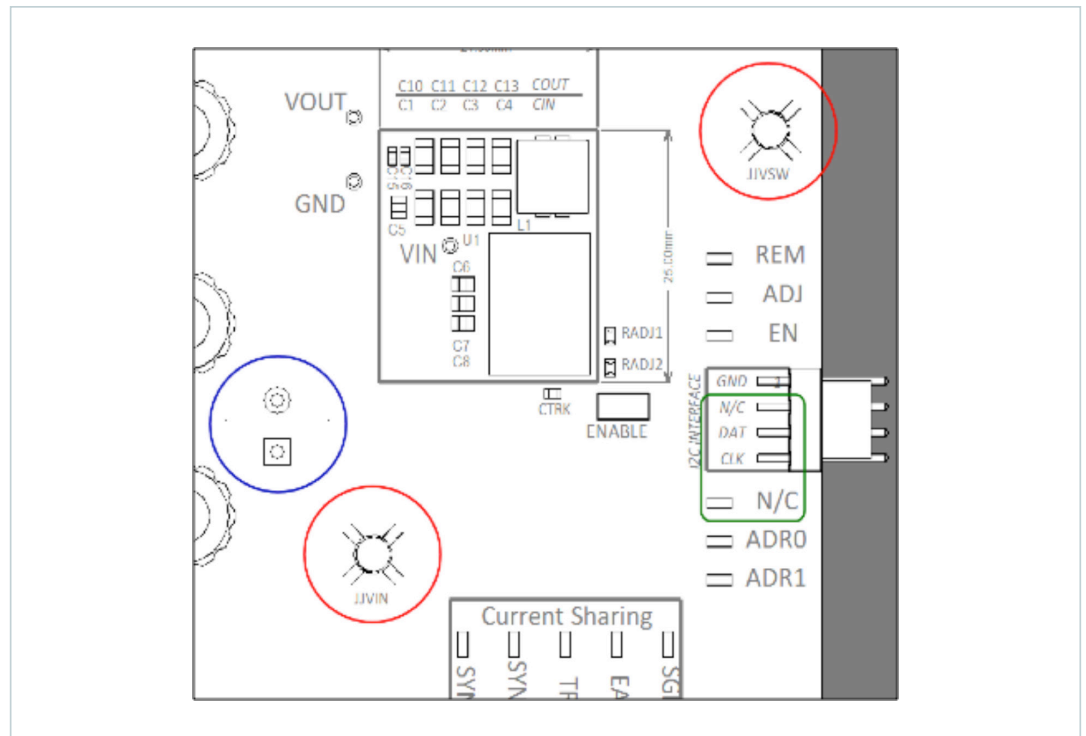

Figure 5.
PI33xx-xx-Eval1
Board Dimensions

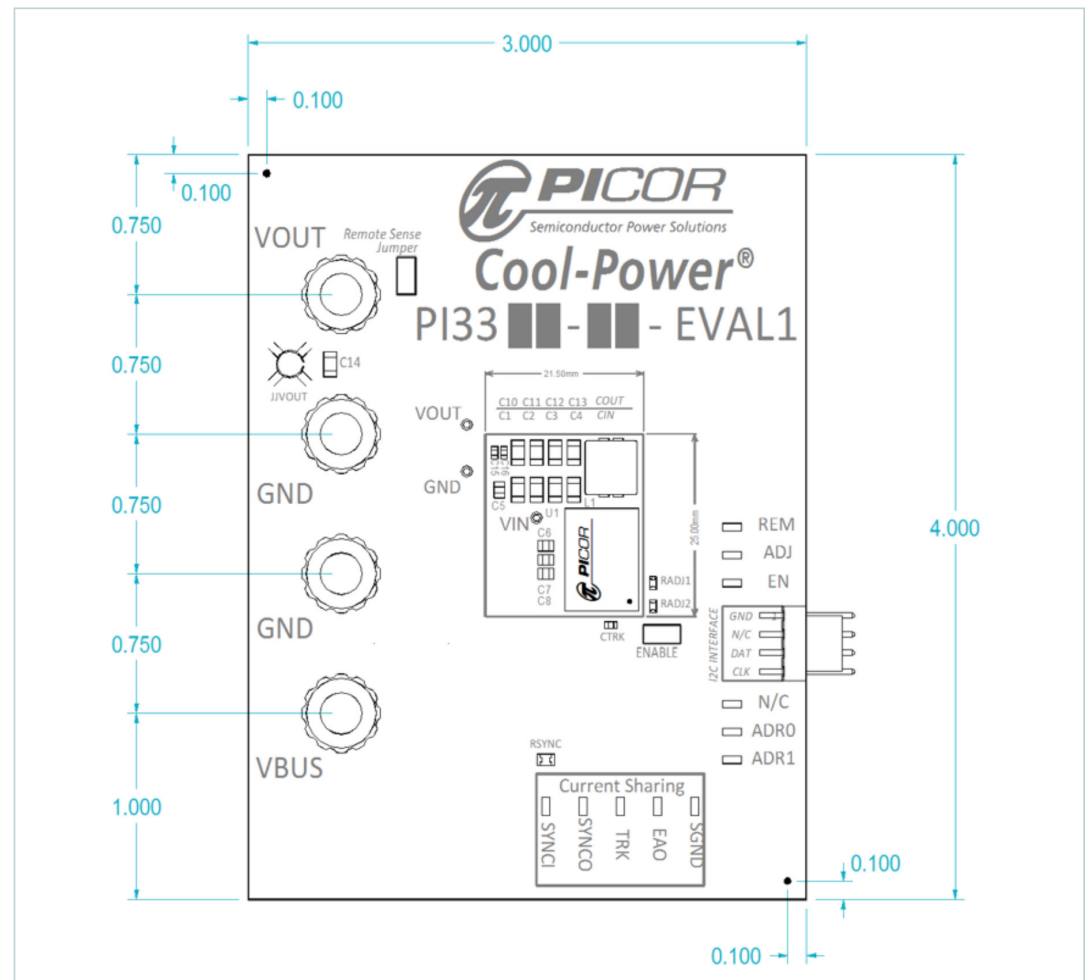
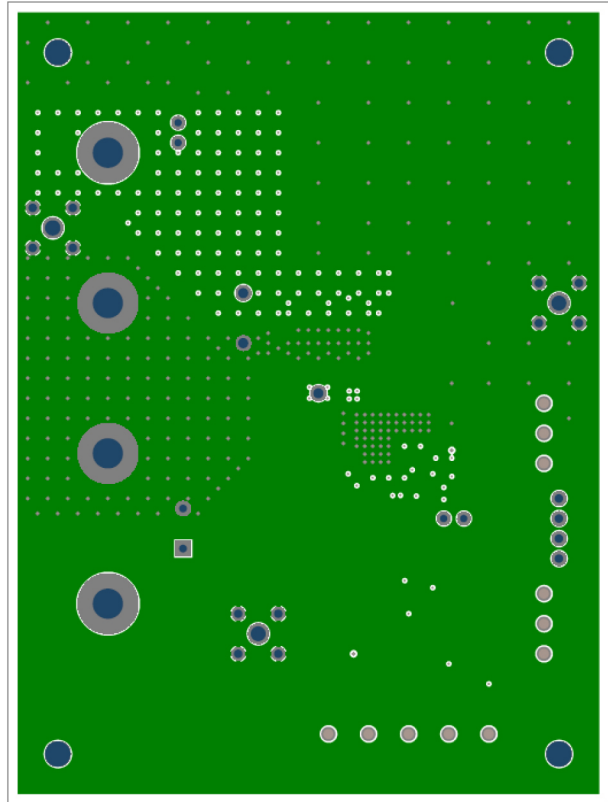

Figure 6.
PCB Metal Layers

Top - Copper



Mid Layer 1 - Copper



Mid Layer 2 - Copper

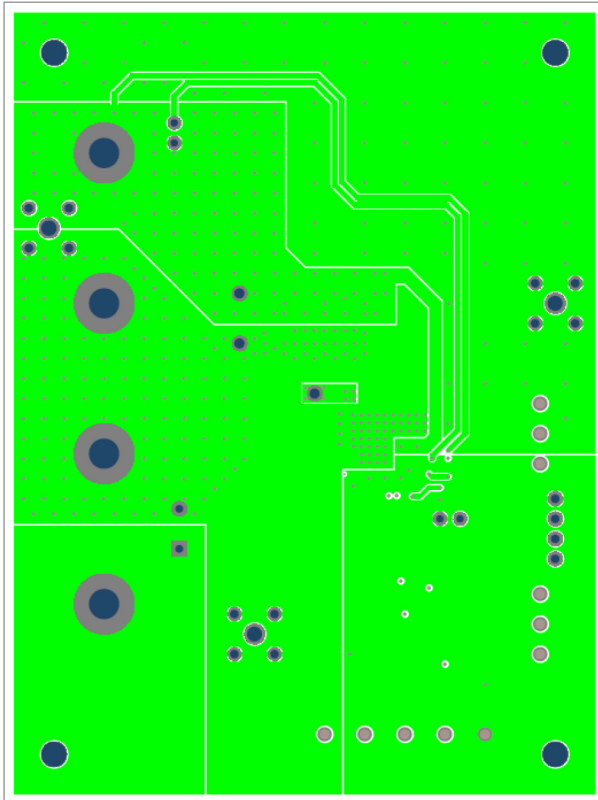

Bottom - Copper

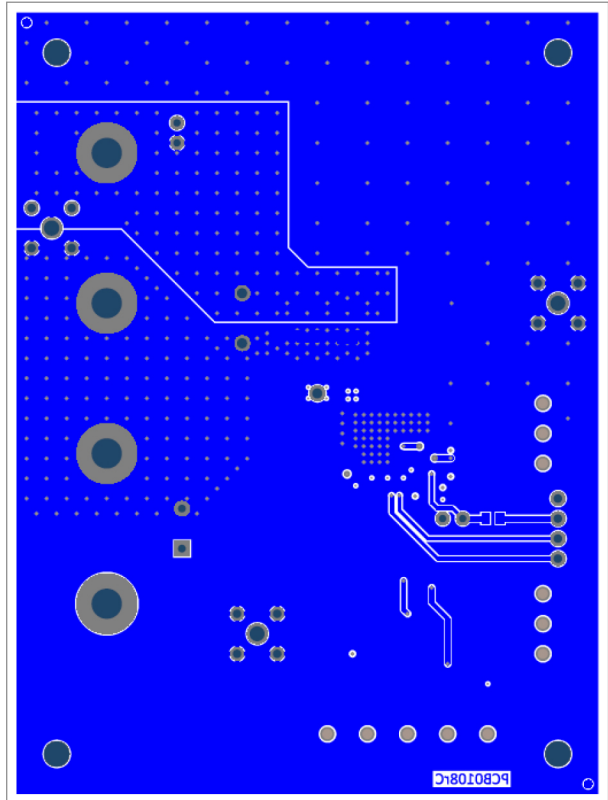



The Power Behind Performance



Стандарт Электрон Связь

Мы молодая и активно развивающаяся компания в области поставок электронных компонентов. Мы поставляем электронные компоненты отечественного и импортного производства напрямую от производителей и с крупнейших складов мира.

Благодаря сотрудничеству с мировыми поставщиками мы осуществляем комплексные и плановые поставки широчайшего спектра электронных компонентов.

Собственная эффективная логистика и склад в обеспечивает надежную поставку продукции в точно указанные сроки по всей России.

Мы осуществляем техническую поддержку нашим клиентам и предпродажную проверку качества продукции. На все поставляемые продукты мы предоставляем гарантию .

Осуществляем поставки продукции под контролем ВП МО РФ на предприятия военно-промышленного комплекса России , а также работаем в рамках 275 ФЗ с открытием отдельных счетов в уполномоченном банке. Система менеджмента качества компании соответствует требованиям ГОСТ ISO 9001.

Минимальные сроки поставки, гибкие цены, неограниченный ассортимент и индивидуальный подход к клиентам являются основой для выстраивания долгосрочного и эффективного сотрудничества с предприятиями радиоэлектронной промышленности, предприятиями ВПК и научно-исследовательскими институтами России.

С нами вы становитесь еще успешнее!

Наши контакты:

Телефон: +7 812 627 14 35

Электронная почта: sales@st-electron.ru

Адрес: 198099, Санкт-Петербург,
Промышленная ул, дом № 19, литера Н,
помещение 100-Н Офис 331