

## DESCRIPTION

Demonstration circuit 579A features the LTC2600 octal 16-bit DAC. This device establishes a new board density benchmark for 16-bit DACs and advances performance standards for output drive, crosstalk and load regulation in single supply, voltage-output multiple DACs.

The DC579A has many features for evaluating the performance of the LTC2600. Onboard 5V and 4.096V precision references are provided, and the LTC2600 may be powered by the 5V reference for evaluating rail-to-rail operation.

Another feature of this board is the onboard LTC2428 20-bit ADC for monitoring DAC output voltage. The 16ppm total error of this device is adequate for taking meaningful measurements of various LTC2600 parameters.

**Design files for this circuit board are available at <http://www.linear.com/demo>**

LT, LT, LTC, LTM, µModule, Linear Technology and the Linear logo are registered trademarks of Linear Technology Corporation. All other trademarks are the property of their respective owners.

## PERFORMANCE SUMMARY

PARAMETER	CONDITIONS	VALUE
Resolution		16 Bits
Monotonicity	$V_{CC} = 5V, V_{REF} = 4.096V$	16 Bits
Differential Nonlinearity	$V_{CC} = 5V, V_{REF} = 4.096V$	$\pm 1LSB$
Integral Nonlinearity	$V_{CC} = 5V, V_{REF} = 4.096V$	$\pm 12LSB$ Typical
Load Regulation	$V_{CC} = V_{REF} = 5V, \text{Mid-Scale}$ $I_{OUT} = \pm 15 \text{ mA}$	2LSB/mA Max
DC Crosstalk	Due to Load Current Change on Any Other Channel	3.5µV/mA

## BOARD PHOTO

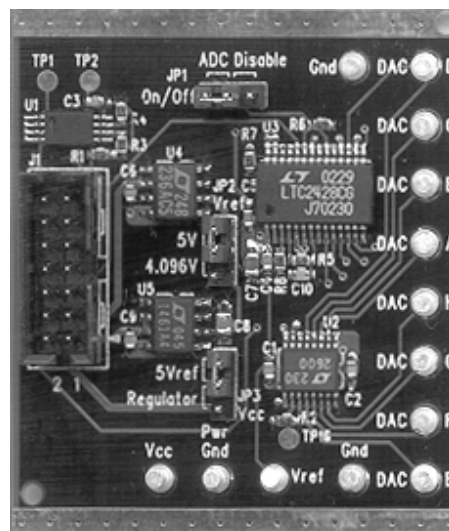

Figure 1. DC579A Demo Board

## QUICK START PROCEDURE

- Connect the DC579A to a DC590 USB serial controller using the supplied 14-conductor ribbon cable.
- Connect the DC590 to a host PC with a standard USB A/B cable.
- Run the evaluation software supplied with the DC590 or download it from [www.linear.com/software](http://www.linear.com/software). The correct control panel will be loaded automatically.
- Click the COLLECT button to begin outputting codes to the DACs and reading back the resulting output voltage for each DAC.

Complete software documentation is available from the Help menu item, as features may be added periodically.

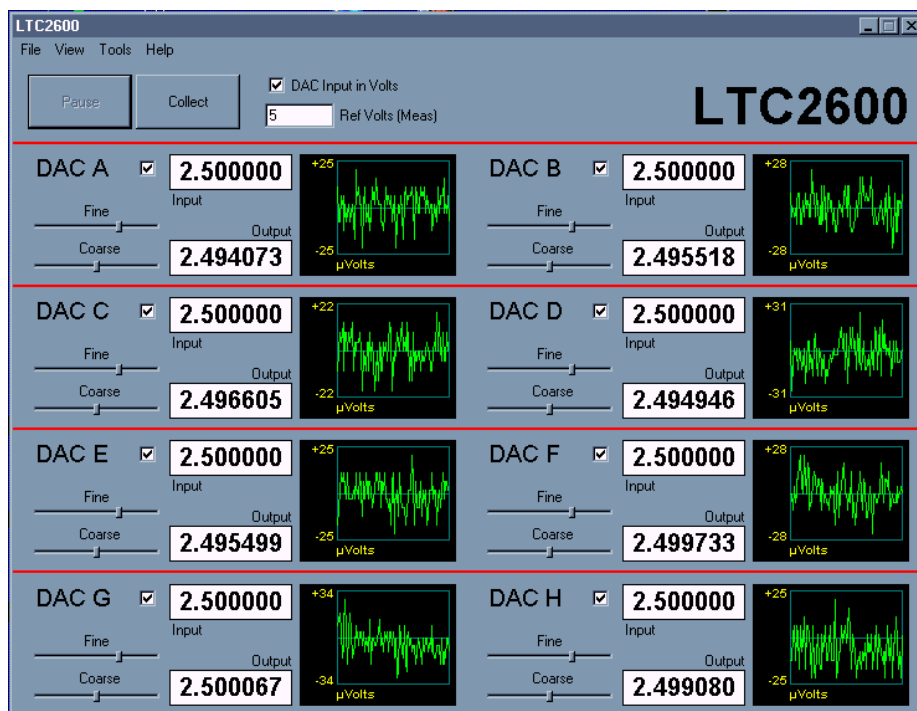

Figure 2. Evaluation Software

## HARDWARE SETUP

### JUMPERS

**JP1 (ADC Disable):** Set to ON for normal operation, with the onboard ADC enabled. For very sensitive noise measurements, the ADC may be disabled. The software will then display a positive full-scale reading.

**JP2 (V<sub>REF</sub> Select):** Either a 5V or 4.096V reference can be selected. To apply an external reference through the V<sub>REF</sub> turret, remove this jumper.

**JP3 (V<sub>CC</sub> Select):** V<sub>CC</sub> is taken either from the onboard 5V reference or the 5V regulated supply from the con-

troller board. Selecting the 5V reference for V<sub>CC</sub> and V<sub>REF</sub> allows characterization of rail-to-rail operation of the LTC2600.

### ANALOG CONNECTIONS

**DAC Outputs:** The eight DAC outputs from the LTC2600 are brought out to turrets labeled DAC A through DAC H. These may be connected to external instruments or other circuitry. DAC outputs are not in alphabetical order on the circuit board.

## HARDWARE SETUP

**V<sub>REF</sub>:** The V<sub>REF</sub> turret is connected directly to the reference terminals of the LTC2600 and LTC2428 ADC. When one of the onboard references is being used, the reference voltage may be monitored at this point. An external reference may also be applied to this turret after removing JP2.

## GROUNDING AND POWER CONNECTIONS

**Power (V<sub>CC</sub>):** Normally the DC579A is powered by the DC590 controller. V<sub>CC</sub> can be supplied to this turret, however the power supply on DC590 must be disabled!

Refer to the DC590 Quick Start Guide for more details on this mode of operation.

**Grounding:** Separate power and signal grounds are provided. Any large currents drawn from the DAC outputs should be returned to power ground. Also, if an external power supply is connected, power ground should be used. Signal ground is connected to the exposed ground planes at the top and bottom edges of the board, and to the two turrets labeled “Gnd.” Use signal ground as the reference point for measurements and connections to external circuits.

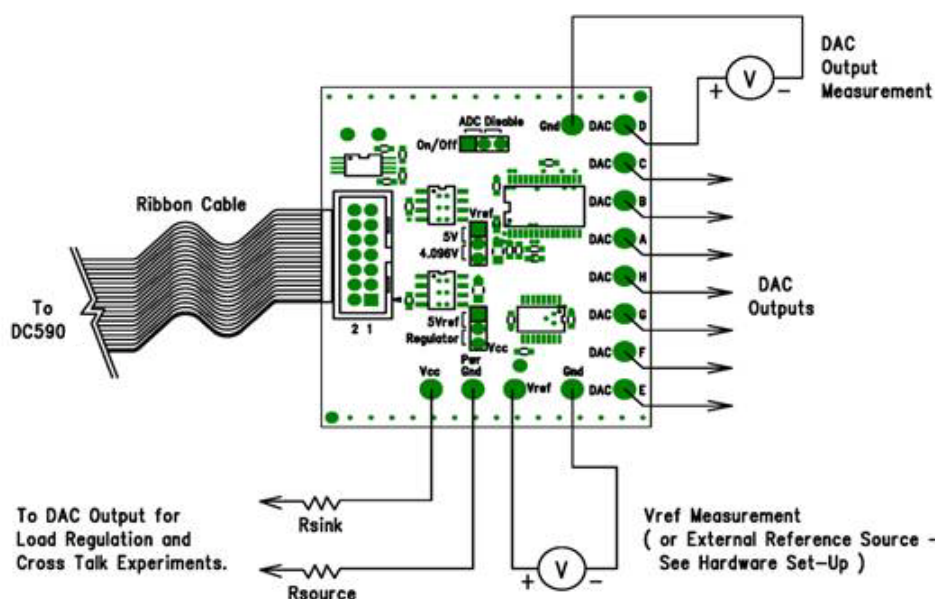

Figure 3. DC579A Setup

## EXPERIMENTS

The following experiments are intended to demonstrate some of the outstanding features of the LTC2600. All can be performed using the onboard LTC2428 to monitor the DAC output voltage. The indicated output voltage will typically agree with an HP3458A voltmeter to five digits. If a DAC will be sinking or sourcing a significant current, then the output voltage should be measured as close to the DAC as possible.

Most of the data sheet specifications use a 4.096V reference, so this is the preferred reference to use for these experiments. Using the 5V reference has the limitation that

V<sub>CC</sub> may be slightly lower than V<sub>REF</sub>, which may affect the full-scale error. Selecting the 5V reference as the source for V<sub>CC</sub> overcomes this, however the total current that the LTC2600 can source will be limited to approximately 5mA.

Using an external power supply is highly recommended for these experiments, especially those that draw significant current. Refer to the DC590 Quick Start Guide for details.

## RESOLUTION

The onboard LTC2428 ADC has an input resolution of 6μV. This will easily resolve a 1LSB (76μV for V<sub>REF</sub> = 5V,

dc579af

## EXPERIMENTS

62.5 $\mu$ V for  $V_{REF} = 4.096V$ ) change in the LTC2600 output. Set one of the DAC channels to a voltage close to mid-scale. Select the FINE slider on the control panel with the mouse and use the right and left arrow keys to step the output by single LSBs. The change should be clearly visible in the output graph. Note: It may be necessary to wait for the graph to clear if a large step has just occurred. This can be sped up by disabling all other DAC channels in the software by unchecking them.

### INTEGRAL NONLINEARITY

A rough measurement of INL can be taken using the onboard ADC. Measure one of the LTC2600 outputs at code 256 and 65,535 and calculate the slope and intercept using a spreadsheet. Next, take several readings at intermediate points. The readings should not deviate from the calculated line by more than 64LSBs, and they will typically be within 12LSBs.

### LOAD REGULATION/DC OUTPUT IMPEDANCE

Select "Regulator" for  $V_{CC}$  source. Set one of the outputs to mid-scale (code 32768). Source or sink 15mA from one of the DAC outputs by pulling it to power ground or  $V_{CC}$  with an appropriate value resistor. The voltage change should be less than 2.25mV, corresponding to an output

impedance of 0.15 $\Omega$ . Output impedance is typically less than 0.030 $\Omega$ . Note: Measure DAC voltage at the output pin if using a voltmeter.

### ZERO-SCALE ERROR

Set one of the DACs to code 0. The measured output should be less than 9mV, and will typically be less than 1mV.

### OFFSET ERROR

Set one of the DACs to code 256. The output voltage should be within 1mV of the correct value, or  $V_{REF} \times 256/65535$ .

### GAIN ERROR

Set one of the DACs to code 65,535. The output voltage should be within 0.7% of  $V_{REF}$ , and will typically be within 0.2%.

### DC CROSSTALK

Set all DACs to mid-scale. Connect a 250 $\Omega$  resistor from one output to  $V_{CC}$  or power ground (to sink or source 10mA, respectively, when the 5V reference is being used). A given output should not change by more than 3.5 $\mu$ V per milliamp of output current in all other DACs combined.

## PARTS LIST

ITEM	QTY	REFERENCE	PART DESCRIPTION	MANUFACTURER/PART NUMBER
1	1	C10	CAP., CHIP, NPO, 100pF, 50V	AVX, 06035A101JAT0603
2	7	C1-C6, C9	CAP., CHIP, X7R, 0.1 $\mu$ F, 16V	AVX, 0603YC104MAT1A0603
3	1	C8	CAP., CHIP, X5R, 1 $\mu$ F, 16V	TAIYO YUDEN, EMK212BJ105MG0805
4	1	C7	CAP., CHIP, X5R, 4.7 $\mu$ F, 6.3V	TAIYO YUDEN, JMK212BJ475MG0805
5	13	TP3-TP15	TURRET, TESTPOINT, 0.064"	MILL-MAX, 2308-2
6	0	TP1, TP2, TP16	OPT.	
7	3	JP1-JP3	HEADER, 3-PIN, 1 ROW, 0.079"	COMM-CON, 2802S-03-G1
8	3	FOR (JP1-JP3)	SHUNT, 0.079" CENTER	COMM-CON, CCIJ2MM-138G
9	1	J1	CONNECTOR, DUAL 2x7, 0.079"	MOLEX, 87331-1420
10	1	R8	RES., CHIP, 22 $\Omega$ , 5%	AAC, CR16-220JM0603
11	3	R1, R3, R4	RES., CHIP, 4.99k, 1%	AAC, CR16-4991FM0603
12	4	R2, R5, R6, R7	RES., CHIP, 7.5k, 5%	AAC, CR16-752JM0603
13	1	U2	I.C., OCTAL, 16-BIT DAC	LINEAR TECHNOLOGY, LTC2600CGN, SSOP-16

dc579af

**PARTS LIST**

ITEM	QTY	REFERENCE	PART DESCRIPTION	MANUFACTURER/PART NUMBER
14	1	U3	I.C., 8-CHANNEL 20-BIT ADC	LINEAR TECHNOLOGY, LTC2428CG, SSOP-28
15	1	U5	I.C., MICROPOWER PRECISION LOW DROPOUT	LINEAR TECHNOLOGY, LT1461ACS8-4, S08
16	1	U4	I.C., PRECISION REFERENCE	LINEAR TECHNOLOGY, LT1236ACS8-5, S08
17	1	U1	I.C., SERIAL EEPROM	MICROCHIP, 24LC025, TSSOP-8

**SCHEMATIC DIAGRAM**

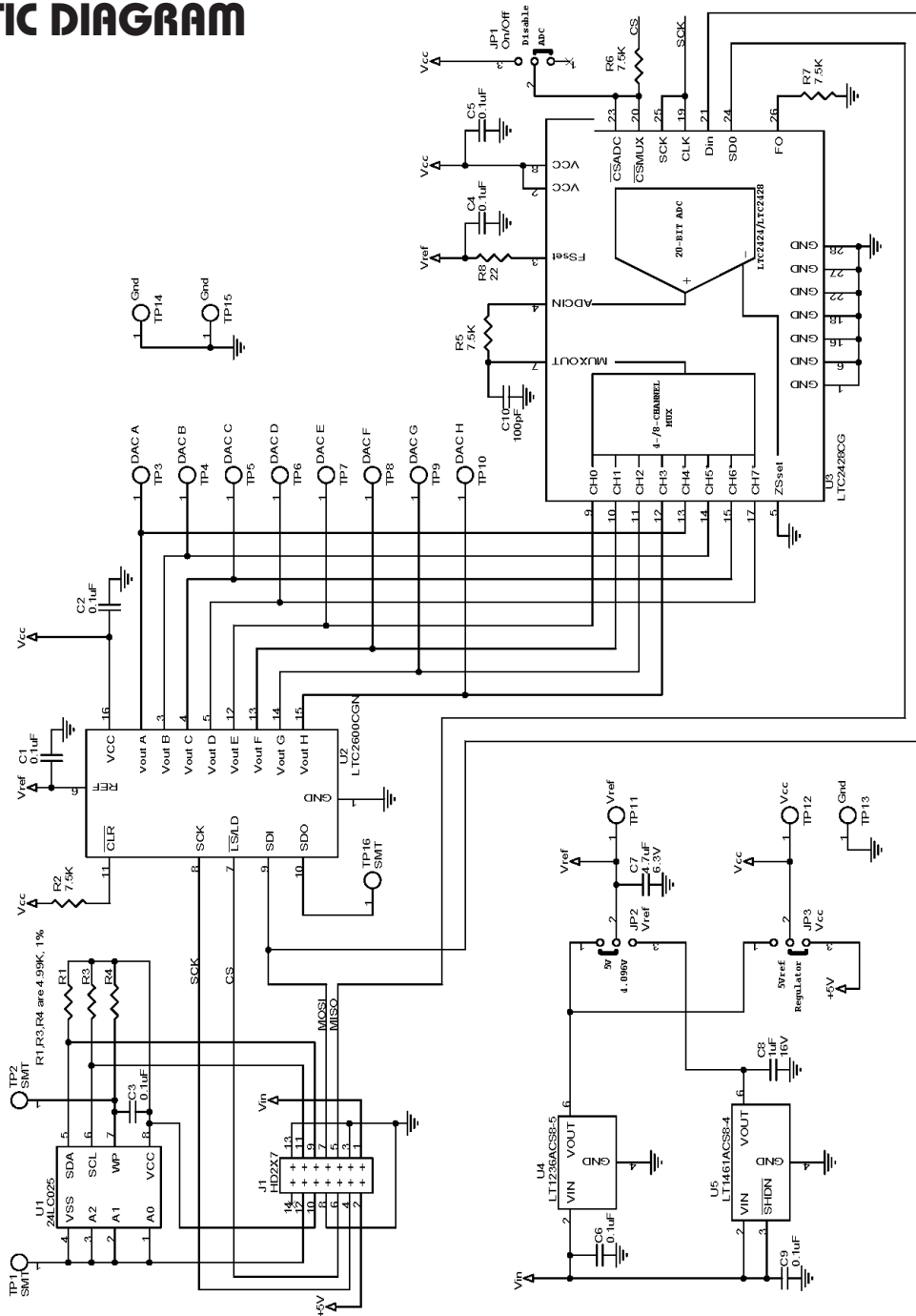

Figure 4. DC579A Octal 16-Bit DAC

# DEMO MANUAL DC579A

---

## DEMONSTRATION BOARD IMPORTANT NOTICE

Linear Technology Corporation (LTC) provides the enclosed product(s) under the following **AS IS** conditions:

This demonstration board (DEMO BOARD) kit being sold or provided by Linear Technology is intended for use for **ENGINEERING DEVELOPMENT OR EVALUATION PURPOSES ONLY** and is not provided by LTC for commercial use. As such, the DEMO BOARD herein may not be complete in terms of required design-, marketing-, and/or manufacturing-related protective considerations, including but not limited to product safety measures typically found in finished commercial goods. As a prototype, this product does not fall within the scope of the European Union directive on electromagnetic compatibility and therefore may or may not meet the technical requirements of the directive, or other regulations.

If this evaluation kit does not meet the specifications recited in the DEMO BOARD manual the kit may be returned within 30 days from the date of delivery for a full refund. **THE FOREGOING WARRANTY IS THE EXCLUSIVE WARRANTY MADE BY THE SELLER TO BUYER AND IS IN LIEU OF ALL OTHER WARRANTIES, EXPRESSED, IMPLIED, OR STATUTORY, INCLUDING ANY WARRANTY OF MERCHANTABILITY OR FITNESS FOR ANY PARTICULAR PURPOSE. EXCEPT TO THE EXTENT OF THIS INDEMNITY, NEITHER PARTY SHALL BE LIABLE TO THE OTHER FOR ANY INDIRECT, SPECIAL, INCIDENTAL, OR CONSEQUENTIAL DAMAGES.**

The user assumes all responsibility and liability for proper and safe handling of the goods. Further, the user releases LTC from all claims arising from the handling or use of the goods. Due to the open construction of the product, it is the user's responsibility to take any and all appropriate precautions with regard to electrostatic discharge. Also be aware that the products herein may not be regulatory compliant or agency certified (FCC, UL, CE, etc.).

No License is granted under any patent right or other intellectual property whatsoever. **LTC assumes no liability for applications assistance, customer product design, software performance, or infringement of patents or any other intellectual property rights of any kind.**

LTC currently services a variety of customers for products around the world, and therefore this transaction **is not exclusive**.

**Please read the DEMO BOARD manual prior to handling the product.** Persons handling this product must have electronics training and observe good laboratory practice standards. **Common sense is encouraged.**

This notice contains important safety information about temperatures and voltages. For further safety concerns, please contact a LTC application engineer.

Mailing Address:

Linear Technology  
1630 McCarthy Blvd.  
Milpitas, CA 95035

Copyright © 2004, Linear Technology Corporation



## Стандарт Электрон Связь

Мы молодая и активно развивающаяся компания в области поставок электронных компонентов. Мы поставляем электронные компоненты отечественного и импортного производства напрямую от производителей и с крупнейших складов мира.

Благодаря сотрудничеству с мировыми поставщиками мы осуществляем комплексные и плановые поставки широчайшего спектра электронных компонентов.

Собственная эффективная логистика и склад в обеспечивает надежную поставку продукции в точно указанные сроки по всей России.

Мы осуществляем техническую поддержку нашим клиентам и предпродажную проверку качества продукции. На все поставляемые продукты мы предоставляем гарантию .

Осуществляем поставки продукции под контролем ВП МО РФ на предприятия военно-промышленного комплекса России , а также работаем в рамках 275 ФЗ с открытием отдельных счетов в уполномоченном банке. Система менеджмента качества компании соответствует требованиям ГОСТ ISO 9001.

Минимальные сроки поставки, гибкие цены, неограниченный ассортимент и индивидуальный подход к клиентам являются основой для выстраивания долгосрочного и эффективного сотрудничества с предприятиями радиоэлектронной промышленности, предприятиями ВПК и научно-исследовательскими институтами России.

С нами вы становитесь еще успешнее!

### Наши контакты:

**Телефон:** +7 812 627 14 35

**Электронная почта:** [sales@st-electron.ru](mailto:sales@st-electron.ru)

**Адрес:** 198099, Санкт-Петербург,  
Промышленная ул, дом № 19, литера Н,  
помещение 100-Н Офис 331