



LatticeECP2/M Family Data Sheet

DS1006 Version 03.3, August 2008

Features

■ High Logic Density for System Integration

- 6K to 95K LUTs
- 90 to 583 I/Os

■ Embedded SERDES (LatticeECP2M Only)

- Data Rates 250 Mbps to 3.125 Gbps
- Up to 16 channels per device
PCI Express, Ethernet (1GbE, SGMII), OBSAI, CPRI and Serial RapidIO.

■ sysDSP™ Block

- 3 to 42 blocks for high performance multiply and accumulate
- Each block supports
 - One 36x36, four 18X18 or eight 9X9 multipliers

■ Flexible Memory Resources

- 55Kbits to 5308Kbits sysMEM™ Embedded Block RAM (EBR)
 - 18Kbit block
 - Single, pseudo dual and true dual port
 - Byte Enable Mode support
- 12K to 202Kbits distributed RAM
 - Single port and pseudo dual port

■ sysCLOCK Analog PLLs and DLLs

- Two GPLLs and up to six SPLLs per device
 - Clock multiply, divide, phase & delay adjust
 - Dynamic PLL adjustment
- Two general purpose DLLs per device

■ Pre-Engineered Source Synchronous I/O

- DDR registers in I/O cells
- Dedicated gearing logic
- Source synchronous standards support
 - SPI4.2, SF14 (DDR Mode), XGMII
 - High Speed ADC/DAC devices
- Dedicated DDR and DDR2 memory support
 - DDR1: 400 (200MHz) / DDR2: 533 (266MHz)
- Dedicated DQS support

■ Programmable sysI/O™ Buffer Supports Wide Range Of Interfaces

- LVTTTL and LVCMOS 33/25/18/15/12
- SSTL 3/2/18 I, II
- HSTL15 I and HSTL18 I, II
- PCI and Differential HSTL, SSTL
- LVDS, RSDS, Bus-LVDS, MLVDS, LVPECL

■ Flexible Device Configuration

- 1149.1 Boundary Scan compliant
- Dedicated bank for configuration I/Os
- SPI boot flash interface
- Dual boot images supported
- TransFR™ I/O for simple field updates
- Soft Error Detect macro embedded

■ Optional Bitstream Encryption (LatticeECP2/M “S” Versions Only)

■ System Level Support

- ispTRACY™ internal logic analyzer capability
- On-chip oscillator for initialization & general use
- 1.2V power supply

Table 1-1. LatticeECP2 (Including “S-Series”) Family Selection Guide

Device	ECP2-6	ECP2-12	ECP2-20	ECP2-35	ECP2-50	ECP2-70
LUTs (K)	6	12	21	32	48	68
Distributed RAM (Kbits)	12	24	42	64	96	136
EBR SRAM (Kbits)	55	221	276	332	387	1032
EBR SRAM Blocks	3	12	15	18	21	60
sysDSP Blocks	3	6	7	8	18	22
18x18 Multipliers	12	24	28	32	72	88
GPLL + SPLL + DLL	2+0+2	2+0+2	2+0+2	2+0+2	2+2+2	2+4+2
Maximum Available I/O	190	297	402	450	500	583
Packages and I/O Combinations						
144-pin TQFP (20 x 20 mm)	90	93				
208-pin PQFP (28 x 28 mm)		131	131			
256-ball fpBGA (17 x 17 mm)	190	193	193			
484-ball fpBGA (23 x 23 mm)		297	331	331	339	
672-ball fpBGA (27 x 27 mm)			402	450	500	500
900-ball fpBGA (31 x 31 mm)						583

© 2007 Lattice Semiconductor Corp. All Lattice trademarks, registered trademarks, patents, and disclaimers are as listed at www.latticesemi.com/legal. All other brand or product names are trademarks or registered trademarks of their respective holders. The specifications and information herein are subject to change without notice.

Table 1-2. LatticeECP2M (Including “S-Series”) Family Selection Guide

Device	ECP2M20	ECP2M35	ECP2M50	ECP2M70	ECP2M100
LUTs (K)	19	34	48	67	95
sysMEM Blocks (18kb)	66	114	225	246	288
Embedded Memory (Kbits)	1217	2101	4147	4534	5308
Distributed Memory (Kbits)	41	71	101	145	202
sysDSP Blocks	6	8	22	24	42
18x18 Multipliers	24	32	88	96	168
GPLL+SPLL+DLL	2+6+2	2+6+2	2+6+2	2+6+2	2+6+2
Maximum Available I/O	304	410	410	436	520
Packages and SERDES / I/O Combinations					
256-ball fpBGA (17 x 17 mm)	4 / 140	4 / 140			
484-ball fpBGA (23 x 23 mm)	4 / 304	4 / 303	4 / 270		
672-ball fpBGA (27 x 27 mm)		4 / 410	8 / 372		
900-ball fpBGA (31 x 31 mm)			8 / 410	16 / 416	16 / 416
1152-ball fpBGA (35 x 35 mm)				16 / 436	16 / 520

Introduction

The LatticeECP2/M family of FPGA devices is optimized to deliver high performance features such as advanced DSP blocks, high speed SERDES (LatticeECP2M family only) and high speed source synchronous interfaces in an economical FPGA fabric. This combination was achieved through advances in device architecture and the use of 90nm technology.

The LatticeECP2/M FPGA fabric is optimized with high performance and low cost in mind. The LatticeECP2/M devices include LUT-based logic, distributed and embedded memory, Phase Locked Loops (PLLs), Delay Locked Loops (DLLs), pre-engineered source synchronous I/O support, enhanced sysDSP blocks and advanced configuration support, including encryption (“S” versions only) and dual boot capabilities.

The LatticeECP2M device family features high speed SERDES with PCS. These high jitter tolerance and low transmission jitter SERDES with PCS blocks can be configured to support an array of popular data protocols including PCI Express, Ethernet (1GbE and SGMII), OBSAI and CPRI. Transmit Pre-emphasis and Receive Equalization settings make SERDES suitable for chip to chip and small form factor backplane applications.

The ispLEVER® design tool suite from Lattice allows large complex designs to be efficiently implemented using the LatticeECP2/M FPGA family. Synthesis library support for LatticeECP2/M is available for popular logic synthesis tools. The ispLEVER tool uses the synthesis tool output along with the constraints from its floor planning tools to place and route the design in the LatticeECP2/M device. The ispLEVER tool extracts the timing from the routing and back-annotates it into the design for timing verification.

Lattice provides many pre-engineered IP (Intellectual Property) ispLeverCORE™ modules for the LatticeECP2/M family. By using these IP cores as standardized blocks, designers are free to concentrate on the unique aspects of their design, increasing their productivity.

Architecture Overview

Each LatticeECP2/M device contains an array of logic blocks surrounded by Programmable I/O Cells (PIC). Interspersed between the rows of logic blocks are rows of sysMEM™ Embedded Block RAM (EBR) and rows of sys-DSP™ Digital Signal Processing blocks, as shown in Figure 2-1. In addition, the LatticeECP2M family contains SERDES Quads in one or more of the corners. Figure 2-2 shows the block diagram of ECP2M20 with one quad.

There are two kinds of logic blocks, the Programmable Functional Unit (PFU) and Programmable Functional Unit without RAM (PFF). The PFU contains the building blocks for logic, arithmetic, RAM and ROM functions. The PFF block contains building blocks for logic, arithmetic and ROM functions. Both PFU and PFF blocks are optimized for flexibility, allowing complex designs to be implemented quickly and efficiently. Logic Blocks are arranged in a two-dimensional array. Only one type of block is used per row.

The LatticeECP2/M devices contain one or more rows of sysMEM EBR blocks. sysMEM EBRs are large dedicated 18K fast memory blocks. Each sysMEM block can be configured in a variety of depths and widths of RAM or ROM. In addition, LatticeECP2/M devices contain up to two rows of DSP Blocks. Each DSP block has multipliers and adder/accumulators, which are the building blocks for complex signal processing capabilities.

The LatticeECP2M devices feature up to 16 embedded 3.125Gbps SERDES (Serializer / Deserializer) channels. Each SERDES channel contains independent 8b/10b encoding / decoding, polarity adjust and elastic buffer logic. Each group of four SERDES channels along with its Physical Coding Sub-layer (PCS) block, creates a quad. The functionality of the SERDES/PCS Quads can be controlled by memory cells set during device configuration or by registers that are addressable during device operation. The registers in every quad can be programmed by a soft IP interface, referred to as the SERDES Client Interface (SCI). These quads (up to four) are located at the corners of the devices.

Each PIC block encompasses two PIOs (PIO pairs) with their respective sysI/O buffers. The sysI/O buffers of the LatticeECP2/M devices are arranged in eight banks, allowing the implementation of a wide variety of I/O standards. In addition, a separate I/O bank is provided for the programming interfaces. PIO pairs on the left and right edges of the device can be configured as LVDS transmit/receive pairs. The PIC logic also includes pre-engineered support to aid in the implementation of high speed source synchronous standards such as SPI4.2, along with memory interfaces including DDR2.

Other blocks provided include PLLs, DLLs and configuration functions. The LatticeECP2/M architecture provides two General PLLs (GPLL) and up to six Standard PLLs (SPLL) per device. In addition, each LatticeECP2/M family member provides two DLLs per device. The GPLLs and DLLs blocks are located in pairs at the end of the bottom-most EBR row; the DLL block is located towards the edge of the device. The SPLL blocks are located at the end of the other EBR/DSP rows.

The configuration block that supports features such as configuration bit-stream decryption, transparent updates and dual boot support is located toward the center of this EBR row. The Ball Grid Array (BGA) package devices in the LatticeECP2/M family supports a sysCONFIG™ port located in the corner between banks four and five, which allows for serial or parallel device configuration.

In addition, every device in the family has a JTAG port. This family also provides an on-chip oscillator and soft error detect capability. The LatticeECP2/M devices use 1.2V as their core voltage.

Figure 2-1. Simplified Block Diagram, ECP2-6 Device (Top Level)

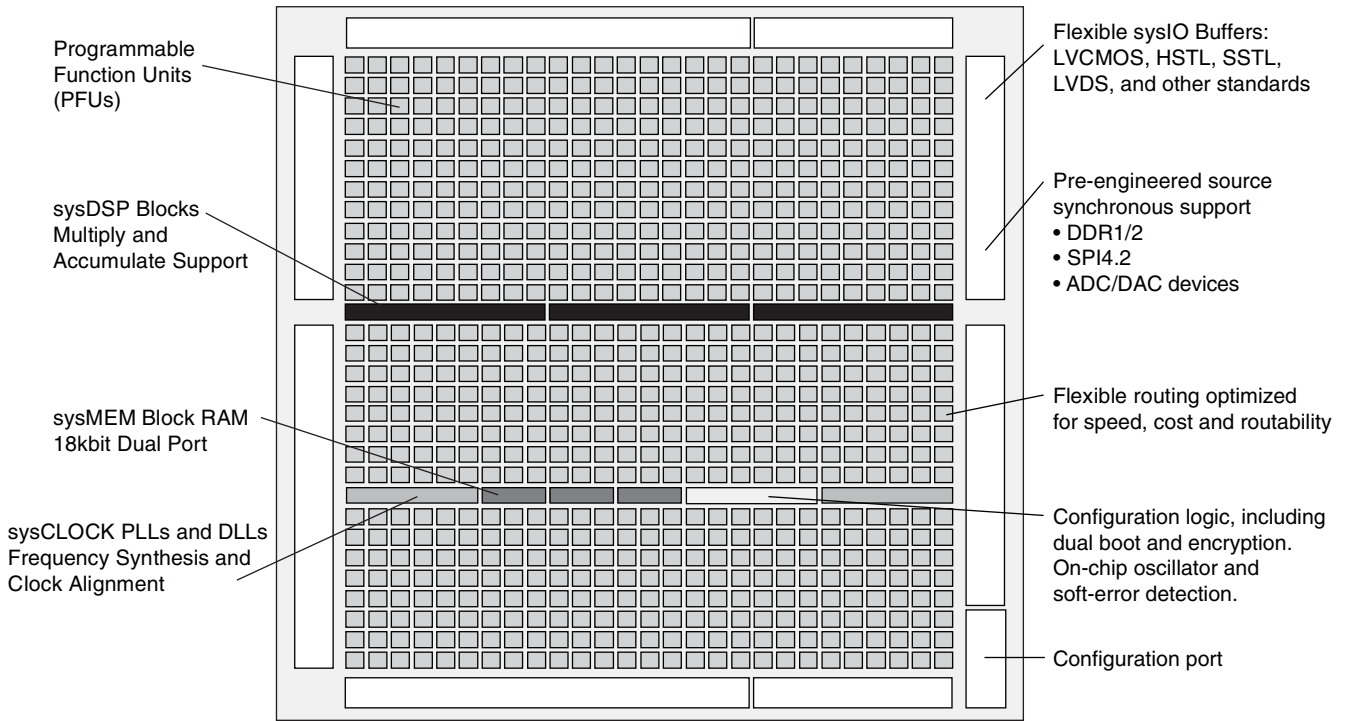
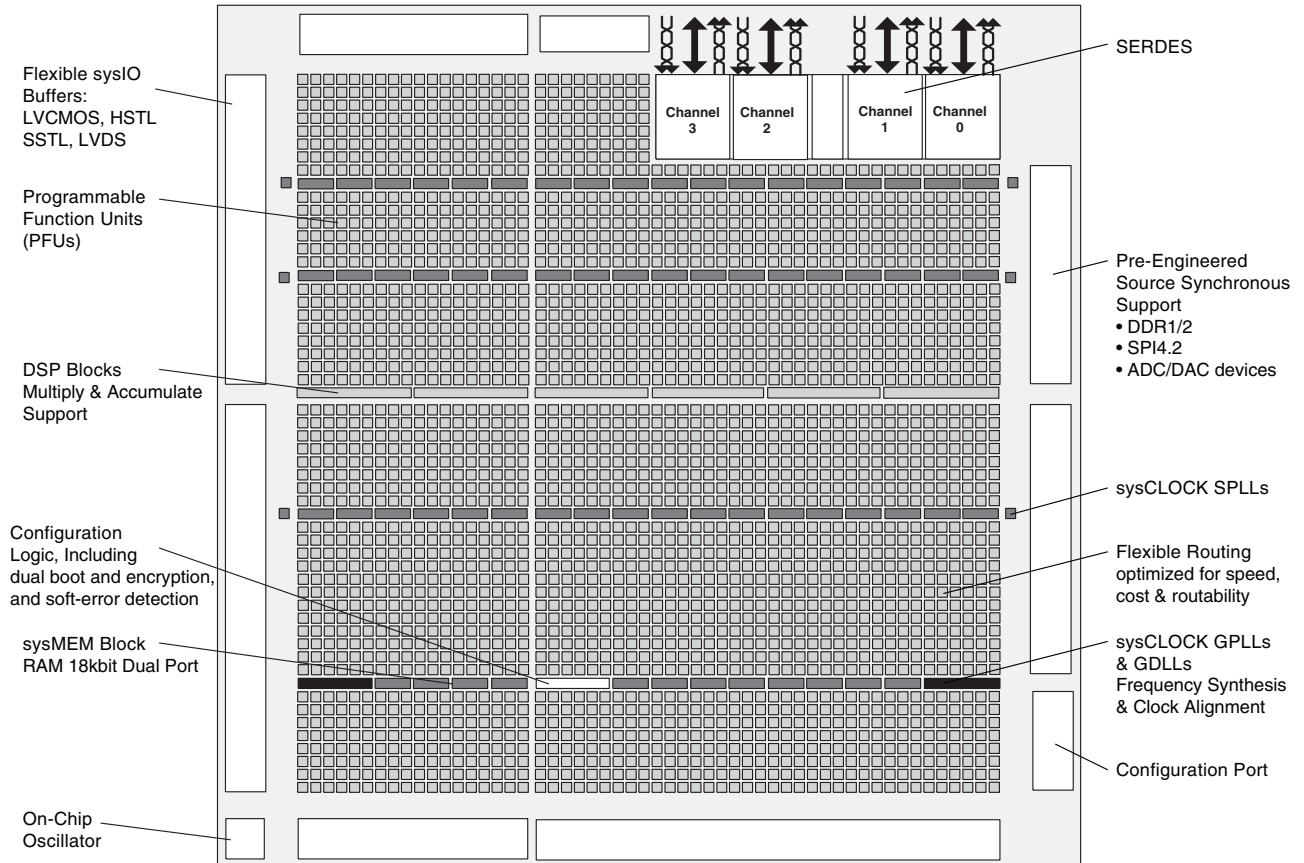

Figure 2-2. Simplified Block Diagram, ECP2M20 Device (Top Level)



PFU Blocks

The core of the LatticeECP2/M device consists of PFU blocks, which are provided in two forms, the PFU and PFF. The PFUs can be programmed to perform Logic, Arithmetic, Distributed RAM and Distributed ROM functions. PFF blocks can be programmed to perform Logic, Arithmetic and ROM functions. Except where necessary, the remainder of this data sheet will use the term PFU to refer to both PFU and PFF blocks.

Each PFU block consists of four interconnected slices, numbered 0-3 as shown in Figure 2-3. All the interconnections to and from PFU blocks are from routing. There are 50 inputs and 23 outputs associated with each PFU block.

Figure 2-3. PFU Diagram

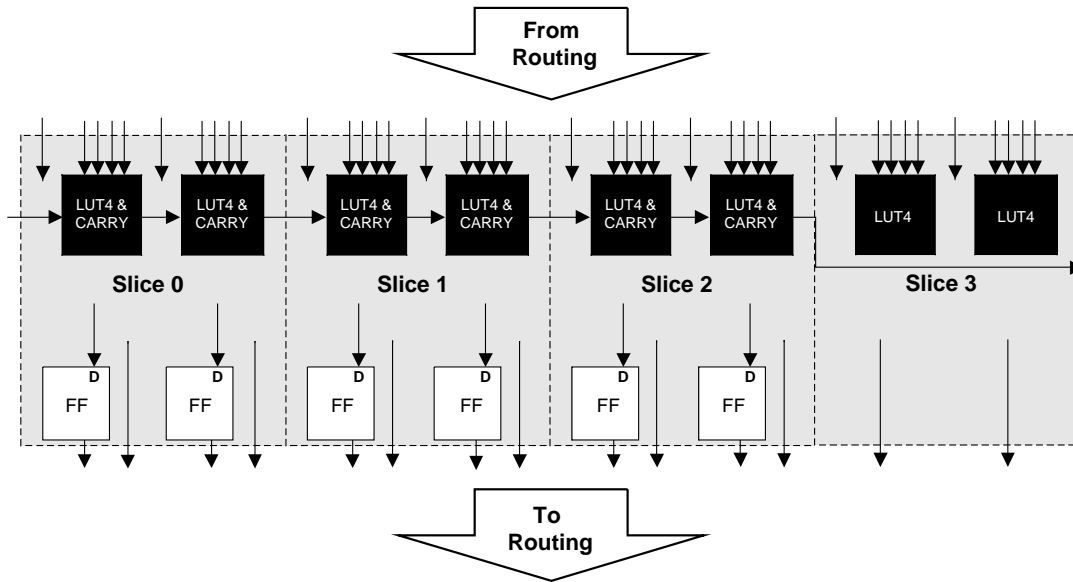

Slice

Slice 0 through Slice 2 contain two LUT4s feeding two registers, whereas Slice 3 contains two LUT4s only. For PFUs, Slice 0 and Slice 2 can also be configured as distributed memory, a capability not available in the PFF. Table 2-1 shows the capability of the slices in both PFF and PFU blocks along with the operation modes they enable. In addition, each PFU contains some logic that allows the LUTs to be combined to perform functions such as LUT5, LUT6, LUT7 and LUT8. There is control logic to perform set/reset functions (programmable as synchronous/asynchronous), clock select, chip-select and wider RAM/ROM functions. Figure 2-4 shows an overview of the internal logic of the slice. The registers in the slice can be configured for positive/negative and edge triggered or level sensitive clocks.

Table 2-1. Resources and Modes Available per Slice

Slice	PFU BLock		PFF Block	
	Resources	Modes	Resources	Modes
Slice 0	2 LUT4s and 2 Registers	Logic, Ripple, RAM, ROM	2 LUT4s and 2 Registers	Logic, Ripple, ROM
Slice 1	2 LUT4s and 2 Registers	Logic, Ripple, ROM	2 LUT4s and 2 Registers	Logic, Ripple, ROM
Slice 2	2 LUT4s and 2 Registers	Logic, Ripple, RAM, ROM	2 LUT4s and 2 Registers	Logic, Ripple, ROM
Slice 3	2 LUT4s	Logic, ROM	2 LUT4s	Logic, ROM

Slices 0, 1 and 2 have 14 input signals: 13 signals from routing and one from the carry-chain (from the adjacent slice or PFU). There are seven outputs: six to routing and one to carry-chain (to the adjacent PFU). Slice 3 has 13 input signals from routing and four signals to routing. Table 2-2 lists the signals associated with Slice 0 to Slice 2.

Figure 2-4. Slice Diagram

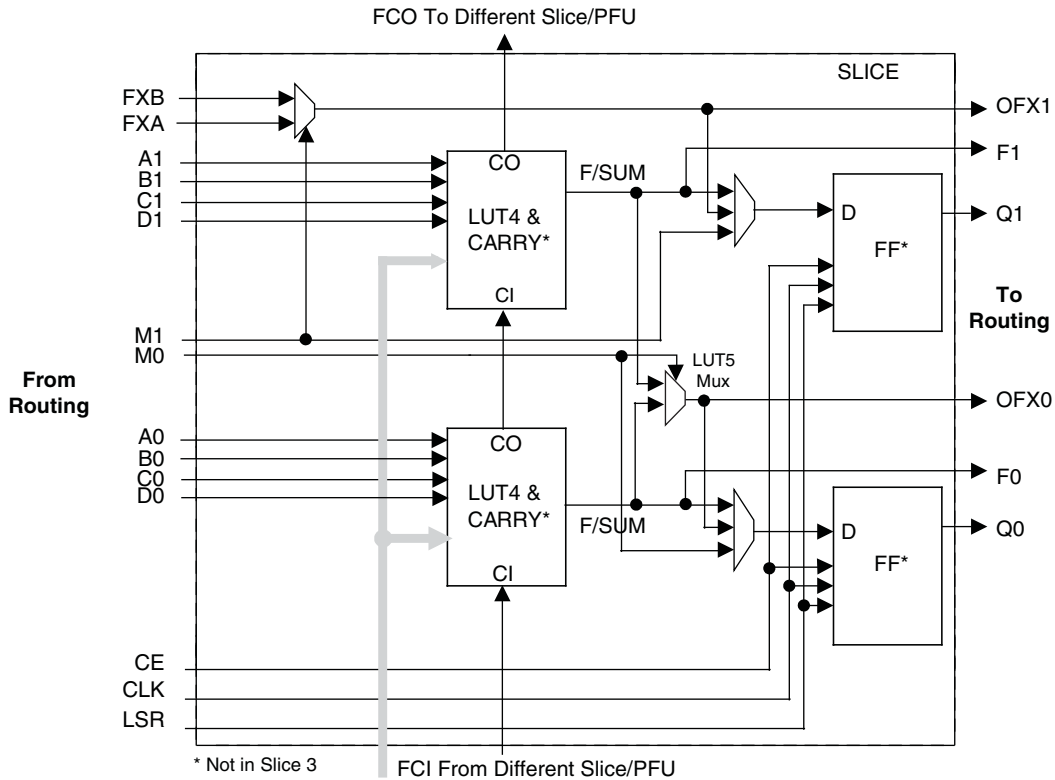

For Slices 0 and 2, memory control signals are generated from Slice 1 as follows:
 WCK is CLK
 WRE is from LSR
 DI[3:2] for Slice 2 and DI[1:0] for Slice 0 data
 WAD [A:D] is a 4bit address from slice 1 LUT input

Table 2-2. Slice Signal Descriptions

Function	Type	Signal Names	Description
Input	Data signal	A0, B0, C0, D0	Inputs to LUT4
Input	Data signal	A1, B1, C1, D1	Inputs to LUT4
Input	Multi-purpose	M0	Multipurpose Input
Input	Multi-purpose	M1	Multipurpose Input
Input	Control signal	CE	Clock Enable
Input	Control signal	LSR	Local Set/Reset
Input	Control signal	CLK	System Clock
Input	Inter-PFU signal	FC	Fast Carry-in ¹
Input	Inter-slice signal	FXA	Intermediate signal to generate LUT6 and LUT7
Input	Inter-slice signal	FXB	Intermediate signal to generate LUT6 and LUT7
Output	Data signals	F0, F1	LUT4 output register bypass signals
Output	Data signals	Q0, Q1	Register outputs
Output	Data signals	OFX0	Output of a LUT5 MUX
Output	Data signals	OFX1	Output of a LUT6, LUT7, LUT8 ² MUX depending on the slice
Output	Inter-PFU signal	FCO	Slice 2 of each PFU is the fast carry chain output ¹

1. See Figure 2-4 for connection details.
 2. Requires two PFUs.

Modes of Operation

Each slice has up to four potential modes of operation: Logic, Ripple, RAM and ROM.

Logic Mode

In this mode, the LUTs in each slice are configured as 4-input combinatorial lookup tables. A LUT4 can have 16 possible input combinations. Any four input logic functions can be generated by programming this lookup table. Since there are two LUT4s per slice, a LUT5 can be constructed within one slice. Larger look-up tables such as LUT6, LUT7 and LUT8 can be constructed by concatenating other slices. Note LUT8 requires more than four slices.

Ripple Mode

Ripple mode supports the efficient implementation of small arithmetic functions. In ripple mode, the following functions can be implemented by each slice:

- Addition 2-bit
- Subtraction 2-bit
- Add/Subtract 2-bit using dynamic control
- Up counter 2-bit
- Down counter 2-bit
- Up/Down counter with Async clear
- Up/Down counter with preload (sync)
- Ripple mode multiplier building block
- Multiplier support
- Comparator functions of A and B inputs
 - A greater-than-or-equal-to B
 - A not-equal-to B
 - A less-than-or-equal-to B

Ripple Mode includes an optional configuration that performs arithmetic using fast carry chain methods. In this configuration (also referred to as CCU2 mode) two additional signals, Carry Generate and Carry Propagate, are generated on a per slice basis to allow fast arithmetic functions to be constructed by concatenating Slices.

RAM Mode

In this mode, a 16x4-bit distributed single port RAM (SPR) can be constructed using each LUT block in Slice 0 and Slice 2 as a 16x1-bit memory. Slice 1 is used to provide memory address and control signals. A 16x2-bit pseudo dual port RAM (PDPR) memory is created by using one Slice as the read-write port and the other companion slice as the read-only port.

The Lattice design tools support the creation of a variety of different size memories. Where appropriate, the software will construct these using distributed memory primitives that represent the capabilities of the PFU. Table 2-3 shows the number of slices required to implement different distributed RAM primitives. For more information about using RAM in LatticeECP2/M devices, please see the list of additional technical documentation at the end of this data sheet.

Table 2-3. Number of Slices Required to Implement Distributed RAM

	SPR 16X4	PDPR 16X4
Number of slices	3	3

Note: SPR = Single Port RAM, PDPR = Pseudo Dual Port RAM

ROM Mode

ROM mode uses the LUT logic; hence, Slices 0 through 3 can be used in ROM mode. Preloading is accomplished through the programming interface during PFU configuration.

Routing

There are many resources provided in the LatticeECP2/M devices to route signals individually or as busses with related control signals. The routing resources consist of switching circuitry, buffers and metal interconnect (routing) segments.

The inter-PFU connections are made with x1 (spans two PFU), x2 (spans three PFU) and x6 (spans seven PFU). The x1 and x2 connections provide fast and efficient connections in horizontal and vertical directions. The x2 and x6 resources are buffered, allowing the routing of both short and long connections between PFUs.

The LatticeECP2/M family has an enhanced routing architecture that produces a compact design. The ispLEVER design tool suite takes the output of the synthesis tool and places and routes the design. Generally, the place and route tool is completely automatic, although an interactive routing editor is available to optimize the design.

sysCLOCK Phase Locked Loops (GPLL/SPLL)

The sysCLOCK PLLs provide the ability to synthesize clock frequencies. All the devices in the LatticeECP2/M family support two General Purpose PLLs (GPLLs) which are full-featured PLLs. In addition, some of the larger devices have two to six Standard PLLs (SPLLs) that have a subset of GPLL functionality.

General Purpose PLL (GPLL)

The architecture of the GPLL is shown in Figure 2-5. A description of the GPLL functionality follows.

CLKI is the reference frequency (generated either from the pin or from routing) for the PLL. CLKI feeds into the Input Clock Divider block. The CLKFB is the feedback signal (generated from CLKOP or from a user clock PIN/logic). This signal feeds into the Feedback Divider. The Feedback Divider is used to multiply the reference frequency.

The Delay Adjust Block adjusts either the delays of the reference or feedback signals. The Delay Adjust Block can either be programmed during configuration or can be adjusted dynamically. The setup, hold or clock-to-out times of the device can be improved by programming a delay in the feedback or input path of the PLL, which will advance or delay the output clock with reference to the input clock.

Following the Delay Adjust Block, both the input path and feedback signals enter the Voltage Controlled Oscillator (VCO) block. In this block the difference between the input path and feedback signals is used to control the frequency and phase of the oscillator. A LOCK signal is generated by the VCO to indicate that the VCO has locked onto the input clock signal. In dynamic mode, the PLL may lose lock after a dynamic delay adjustment and not relock until the t_{LOCK} parameter has been satisfied. LatticeECP2/M devices have two dedicated pins on the left and right edges of the device for connecting optional external capacitors to the VCO. This allows the PLLs to operate at a lower frequency. This is a shared resource that can only be used by one PLL (GPLL or SPLL) per side.

The output of the VCO then enters the post-scalar divider. The post-scalar divider allows the VCO to operate at higher frequencies than the clock output (CLKOP), thereby increasing the frequency range. A secondary divider takes the CLKOP signal and uses it to derive lower frequency outputs (CLKOK). The Phase/Duty Select block adjusts the phase and duty cycle of the CLKOP signal and generates the CLKOS signal. The phase/duty cycle setting can be pre-programmed or dynamically adjusted.

The primary output from the post scalar divider CLKOP along with the outputs from the secondary divider (CLKOK) and Phase/Duty select (CLKOS) are fed to the clock distribution network.

Figure 2-5. General Purpose PLL (GPLL) Diagram

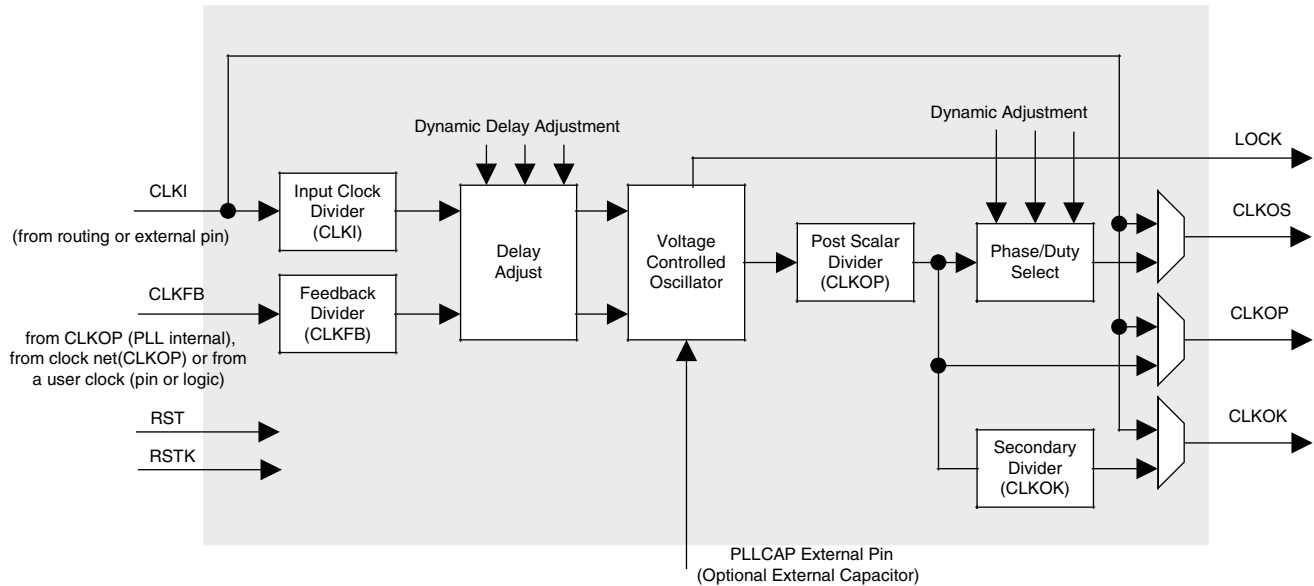

Standard PLL (SPLL)

Some of the larger devices have two to six Standard PLLs (SPLLs). SPLLs have the same features as GPLLs but without delay adjustment capability. SPLLs also provide different parametric specifications. For more information, please see the list of additional technical documentation at the end of this data sheet.

Table 2-4 provides a description of the signals in the GPLL and SPLL blocks.

Table 2-4. GPLL and SPLL Blocks Signal Descriptions

Signal	I/O	Description
CLKI	I	Clock input from external pin or routing
CLKFB	I	PLL feedback input from CLKOP (PLL internal), from clock net (CLKOP) or from a user clock (PIN or logic)
RST	I	"1" to reset PLL counters, VCO, charge pumps and M-dividers
RSTK	I	"1" to reset K-divider
CLKOS	O	PLL output clock to clock tree (phase shifted/duty cycle changed)
CLKOP	O	PLL output clock to clock tree (no phase shift)
CLKOK	O	PLL output to clock tree through secondary clock divider
LOCK	O	"1" indicates PLL LOCK to CLKI
DDAMODE ¹	I	Dynamic Delay Enable. "1": Pin control (dynamic), "0": Fuse Control (static)
DDAIZR ¹	I	Dynamic Delay Zero. "1": delay = 0, "0": delay = on
DDAILAG ¹	I	Dynamic Delay Lag/Lead. "1": Lead, "0": Lag
DDAIDEL[2:0] ¹	I	Dynamic Delay Input
DPA MODES	I	DPA (Dynamic Phase Adjust/Duty Cycle Select) mode
DPHASE [3:0]	I	DPA Phase Adjust inputs
DDDUTY [3:0]	—	DPA Duty Cycle Select inputs

1. These signals are not available in SPLL.

Delay Locked Loops (DLL)

In addition to PLLs, the LatticeECP2/M family of devices has two DLLs per device.

CLKI is the input frequency (generated either from the pin or routing) for the DLL. CLKI feeds into the output muxes block to bypass the DLL, directly to the DELAY CHAIN block and (directly or through divider circuit) to the reference input of the Phase Frequency Detector (PFD) input mux. The reference signal for the PFD can also be generated from the Delay Chain and CLKFB signals. The feedback input to the PFD is generated from the CLKFB pin, CLKI or from tapped signal from the Delay chain.

The PFD produces a binary number proportional to the phase and frequency difference between the reference and feedback signals. This binary output of the PFD is fed into a Arithmetic Logic Unit (ALU). Based on these inputs, the ALU determines the correct digital control codes to send to the delay chain in order to better match the reference and feedback signals. This digital code from the ALU is also transmitted via the Digital Control bus (DCNTL) bus to its associated DLLDELA delay block. The ALUHOLD input allows the user to suspend the ALU output at its current value. The UDDCNTL signal allows the user to latch the current value on the DCNTL bus.

The DLL has two independent clock outputs, CLKOP and CLKOS. These outputs can individually select one of the outputs from the tapped delay line. The CLKOS has optional fine phase shift and divider blocks to allow this output to be further modified, if required. The fine phase shift block allows the CLKOS output to phase shifted a further 45, 22.5 or 11.25 degrees relative to its normal position. Both the CLKOS and CLKOP outputs are available with optional duty cycle correction. Divide by two and divide by four frequencies are available at CLKOS. The LOCK output signal is asserted when the DLL is locked. Figure 2-6 shows the DLL block diagram and Table 2-5 provides a description of the DLL inputs and outputs.

The user can configure the DLL for many common functions such as time reference delay mode and clock injection removal mode. Lattice provides primitives in its design tools for these functions. For more information about the DLL, please see the list of additional technical documentation at the end of this data sheet.

Figure 2-6. Delay Locked Loop Diagram (DLL)

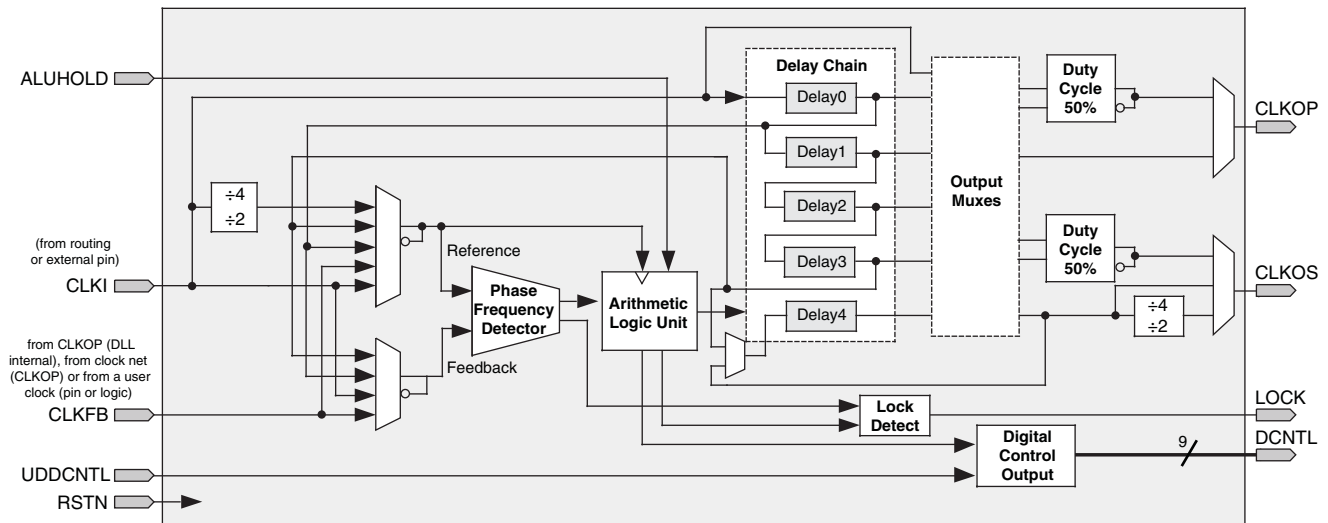

Table 2-5. DLL Signals

Signal	I/O	Description
CLKI	I	Clock input from external pin or routing
CLKFB	I	DLL feed input from DLL output, clock net, routing or external pin
RSTN	I	Active low synchronous reset
ALUHOLD	I	Active high freezes the ALU
UDDCNTL	I	Synchronous enable signal (hold high for two cycles) from routing
DCNTL[8:0]	O	Encoded digital control signals for PIC INDEL and slave delay calibration
CLKOP	O	The primary clock output
CLKOS	O	The secondary clock output with fine phase shift and/or division by 2 or by 4
LOCK	O	Active high phase lock indicator

DLLDELA Delay Block

Closely associated with each DLL is a DLLDELA block. This is a delay block consisting of a delay line with taps and a selection scheme that selects one of the taps. The DCNTL[8:0] bus controls the delay of the CLKO signal. Typically this is the delay setting that the DLL uses to achieve phase alignment. This results in the delay providing a calibrated 90° phase shift that is useful in centering a clock in the middle of a data cycle for source synchronous data. The CLKO signal feeds the edge clock network. Figure 2-7 shows the connections between the DLL block and the DLLDELA delay block. For more information, please see the list of additional technical documentation at the end of this data sheet.

Figure 2-7. DLLDELA Delay Block

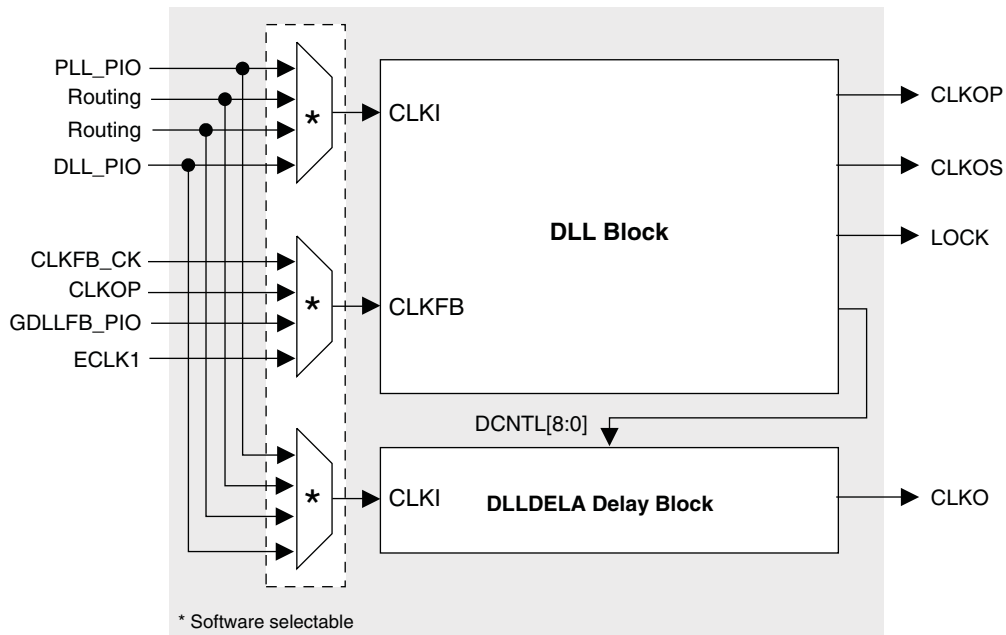

PLL/DLL Cascading

LatticeECP2/M devices have been designed to allow certain combinations of PLL (GPLL and SPLL) and DLL cascading. The allowable combinations are:

- PLL to PLL supported
- PLL to DLL supported

The DLLs in the LatticeECP2/M are used to shift the clock in relation to the data for source synchronous inputs. PLLs are used for frequency synthesis and clock generation for source synchronous interfaces. Cascading PLL and DLL blocks allows applications to utilize the unique benefits of both DLLs and PLLs.

For further information about the DLL, please see the list of additional technical documentation at the end of this data sheet.

GPLL/SPLL/GDLL PIO Input Pin Connections (LatticeECP2M Family Only)

All LatticeECP2M devices contain two GDLLs, two GPLLs and six SPLLs, arranged in quadrants as shown in Figure 2-8. In the LatticeECP2M devices GPLLs, SPLLs and GDLLs share their input pins. Figure 2-8 shows the sharing of SPLLs input pin connections in the upper two quadrants and the sharing of GDLL, GPLL and SPLL input pin connections in the lower two quadrants.

Figure 2-8. Sharing of PIO Pins by GPLL, SPLL and GDLL in LatticeECP2M Devices

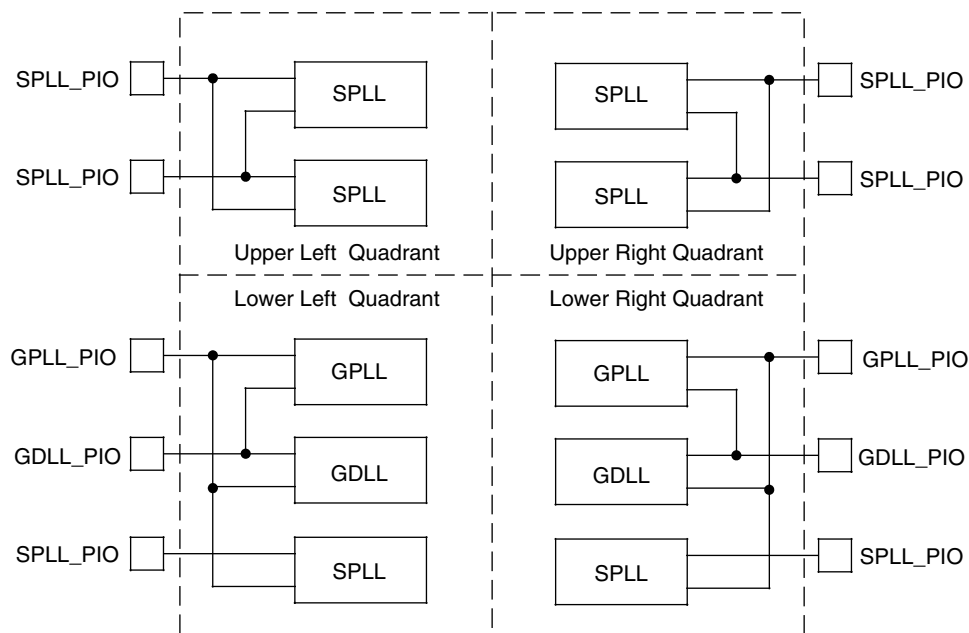

Clock Dividers

LatticeECP2/M devices have two clock dividers, one on the left side and one on the right side of the device. These are intended to generate a slower-speed system clock from a high-speed edge clock. The block operates in a $\div 2$, $\div 4$ or $\div 8$ mode and maintains a known phase relationship between the divided down clock and the high-speed clock based on the release of its reset signal. The clock dividers can be fed from selected PLL/DLL outputs, DLL-DELA delay blocks, routing or from an external clock input. The clock divider outputs serve as primary clock sources and feed into the clock distribution network. The Reset (RST) control signal resets input and synchronously forces all outputs to low. The RELEASE signal releases outputs synchronously to the input clock. For further information about clock dividers, please see the list of additional technical documentation at the end of this data sheet. Figure 2-9 shows the clock divider connections.

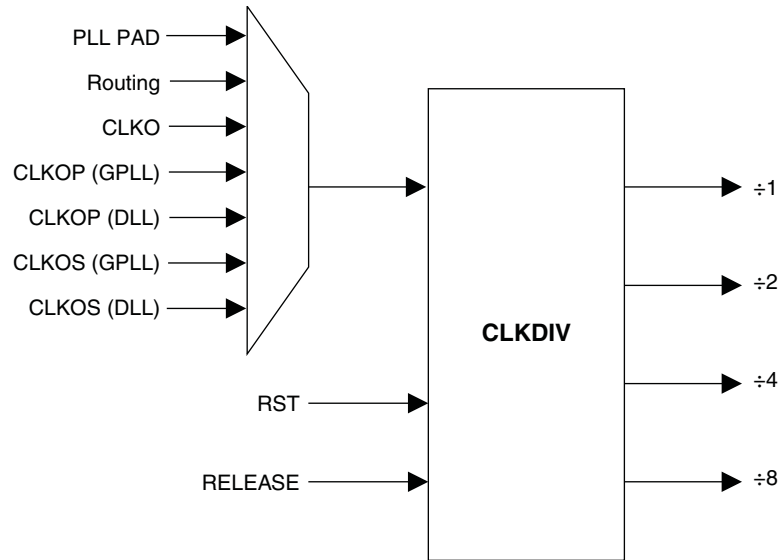
Figure 2-9. Clock Divider Connections

Clock Distribution Network

LatticeECP2/M devices have eight quadrant-based primary clocks and eight flexible region-based secondary clocks/control signals. Two high performance edge clocks are available on each edge of the device to support high speed interfaces. These clock inputs are selected from external I/Os, the sysCLOCK PLLs, DLLs or routing. These clock inputs are fed throughout the chip via a clock distribution system.

Primary Clock Sources

LatticeECP2/M devices derive clocks from five primary sources: PLL (GPLL and SPLL) outputs, DLL outputs, CLKDIV outputs, dedicated clock inputs and routing. LatticeECP2/M devices have two to eight sysCLOCK PLLs and two DLLs, located on the left and right sides of the device. There are eight dedicated clock inputs, two on each side of the device, with the exception of the LatticeECP2M 256-fpBGA package devices which have six dedicated clock inputs on the device. Figure 2-10 shows the primary clock sources.

Figure 2-10. Primary Clock Sources for ECP2-50

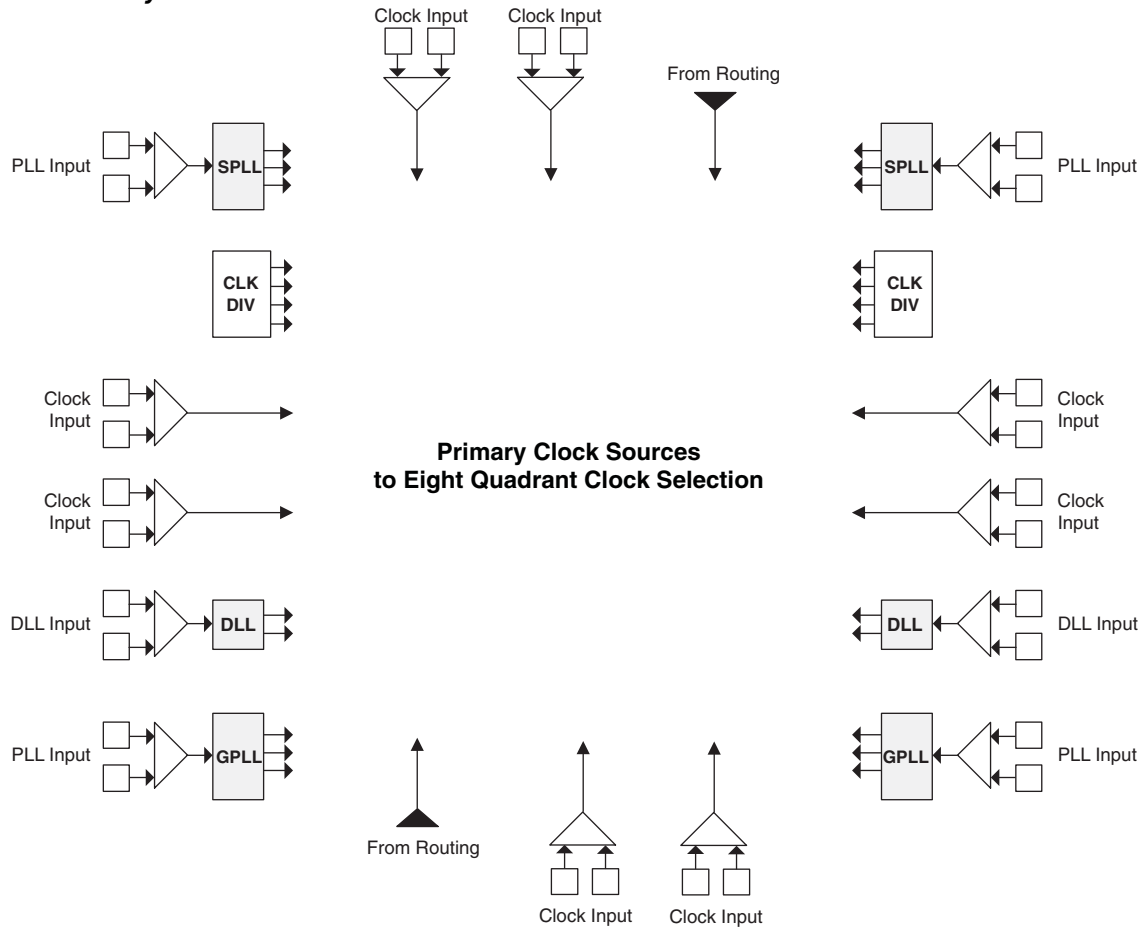

Note: This diagram shows sources for the ECP2-50 device. Smaller LatticeECP2 devices have fewer SPLLs. All LatticeECP2M device have six SPLLs.

Secondary Clock/Control Sources

LatticeECP2/M devices derive secondary clocks (SC0 through SC7) from eight dedicated clock input pads and the rest from routing. Figure 2-11 shows the secondary clock sources.

Figure 2-11. Secondary Clock Sources

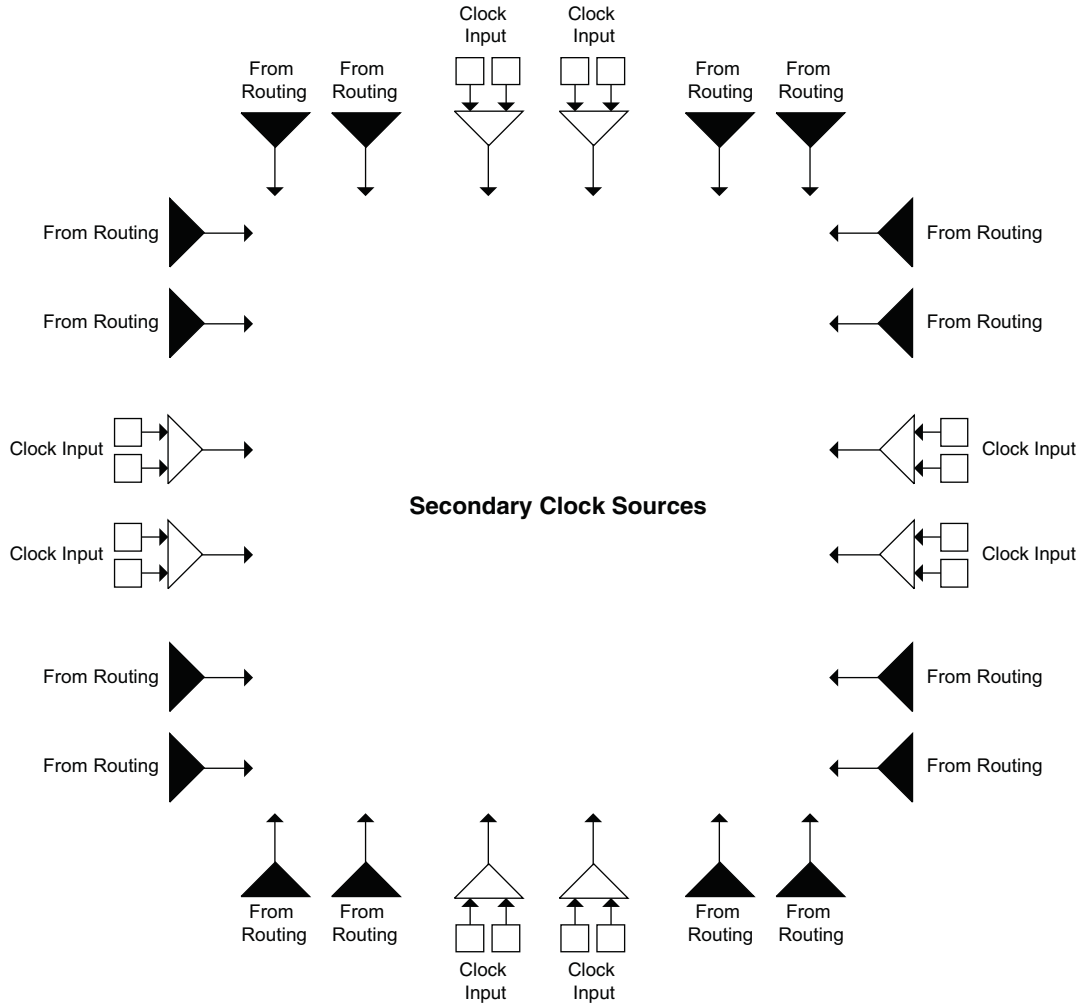

Edge Clock Sources

Edge clock resources can be driven from a variety of sources at the same edge. Edge clock resources can be driven from adjacent edge clock PIOs, primary clock PIOs, PLLs/DLLs and clock dividers as shown in Figure 2-12.

Figure 2-12. Edge Clock Sources

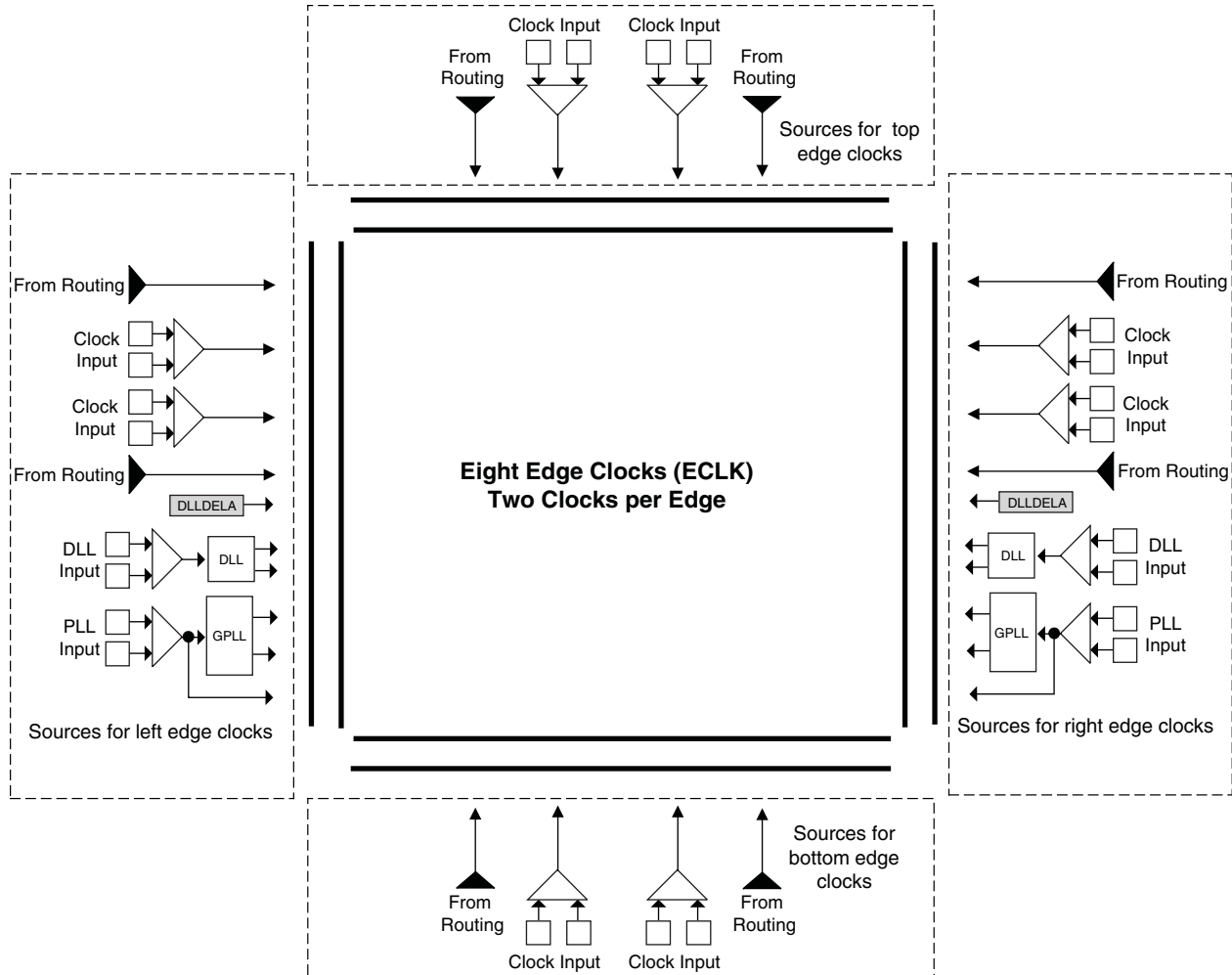

Primary Clock Routing

The clock routing structure in LatticeECP2/M devices consists of a network of eight primary clock lines (CLK0 through CLK7) per quadrant. The primary clocks of each quadrant are generated from muxes located in the center of the device. All the clock sources are connected to these muxes. Figure 2-13 shows the clock routing for one quadrant. Each quadrant mux is identical. If desired, any clock can be routed globally

Figure 2-13. Per Quadrant Primary Clock Selection

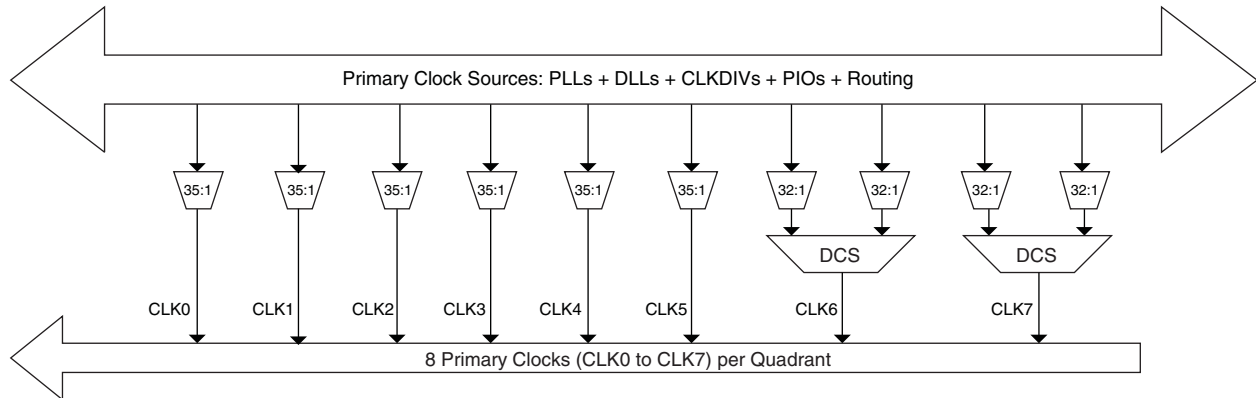

Dynamic Clock Select (DCS)

The DCS is a smart multiplexer function available in the primary clock routing. It switches between two independent input clock sources without any glitches or runt pulses. This is achieved regardless of when the select signal is toggled. There are two DCS blocks per quadrant; in total, there are eight DCS blocks per device. The inputs to the DCS block come from the center muxes. The output of the DCS is connected to primary clocks CLK6 and CLK7 (see Figure 2-13).

Figure 2-14 shows the timing waveforms of the default DCS operating mode. The DCS block can be programmed to other modes. For more information about the DCS, please see the list of additional technical documentation at the end of this data sheet.

Figure 2-14. DCS Waveforms

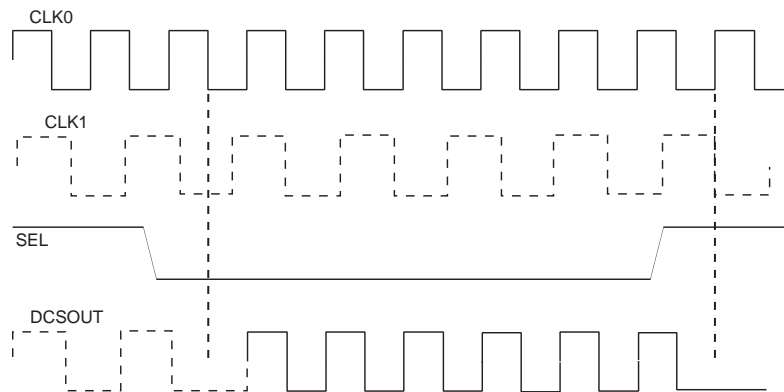

Secondary Clock/Control Routing

Secondary clocks in the LatticeECP2 devices are region-based resources. The benefit of region-based resources is the relatively low injection delay and skew within the region, as compared to primary clocks. EBR/DSP rows and a special vertical routing channel bound the secondary clock regions. This special vertical routing channel aligns with either the left edge of the center DSP block in the DSP row or the center of the DSP row. Figure 2-15 shows

this special vertical routing channel and the eight secondary clock regions for the ECP2-50. LatticeECP2 devices have four secondary clocks (SC0 to SC3) which are distributed to every region.

The secondary clock muxes are located in the center of the device. Figure 2-16 shows the mux structure of the secondary clock routing. Secondary clocks SC0 to SC3 are used for clock and control and SC4 to SC7 are used for high fan-out signals.

Figure 2-15. Secondary Clock Regions ECP2-50

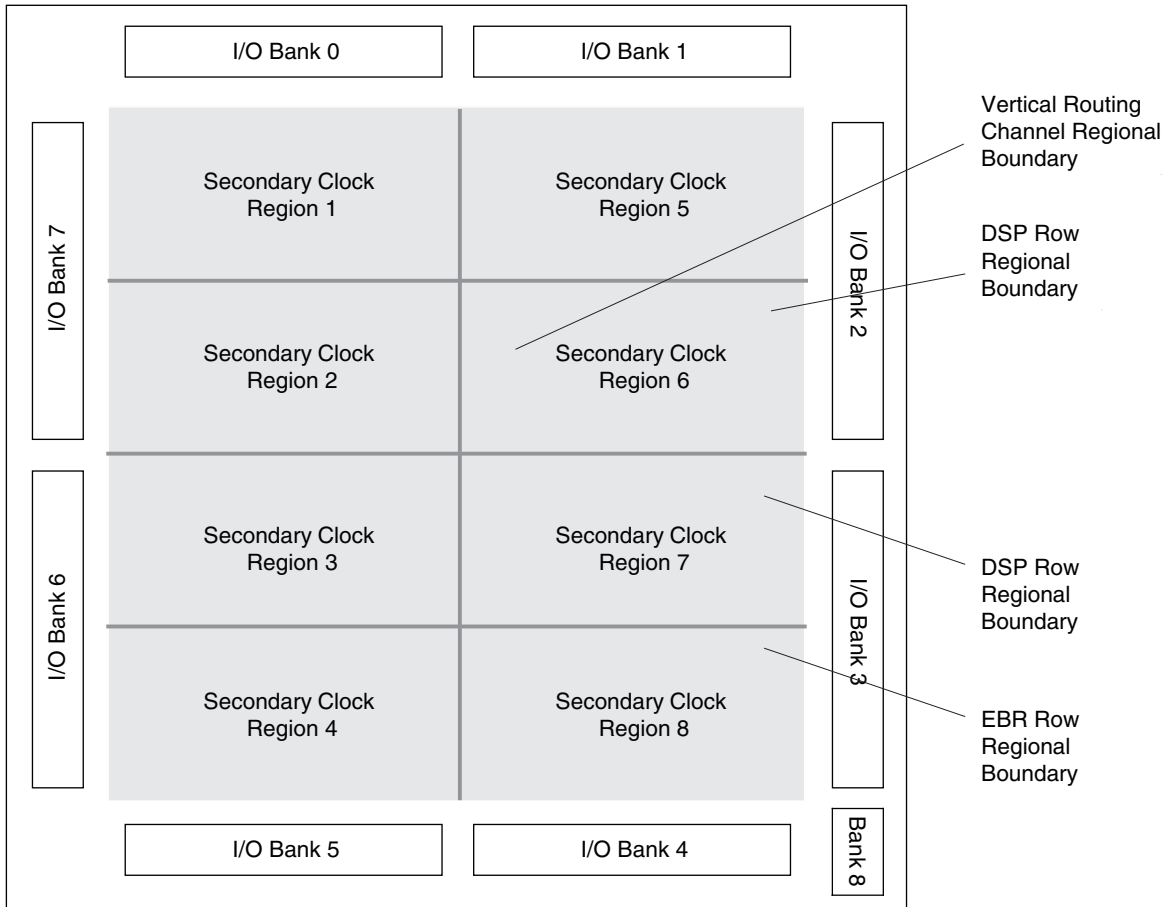
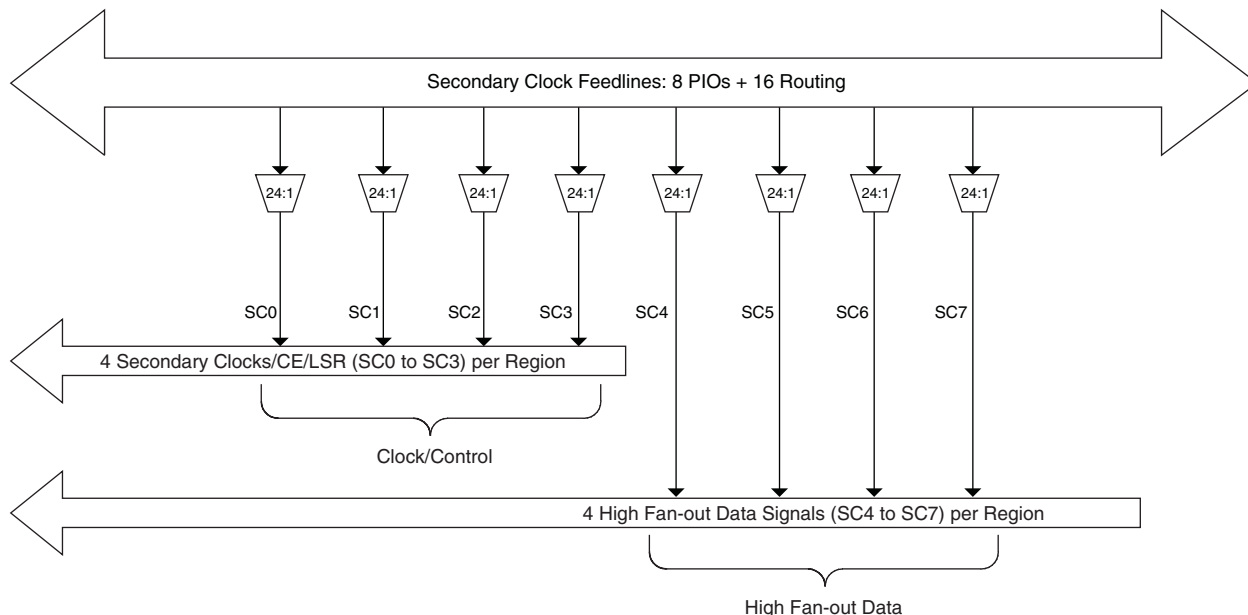

Figure 2-16. Secondary Clock Selection



Slice Clock Selection

Figure 2-17 shows the clock selections and Figure 2-18 shows the control selections for Slice0 through Slice2. All the primary clocks and the four secondary clocks are routed to this clock selection mux. Other signals can be used as a clock input to the slices via routing. Slice controls are generated from the secondary clocks or other signals connected via routing.

If none of the signals are selected for both clock and control then the default value of the mux output is 1. Slice 3 does not have any registers; therefore it does not have the clock or control muxes.

Figure 2-17. Slice0 through Slice2 Clock Selection

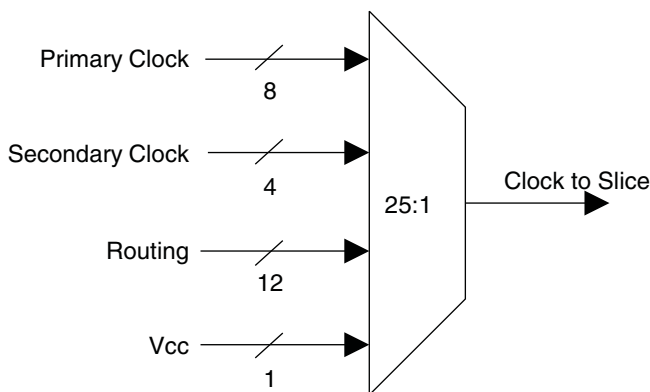
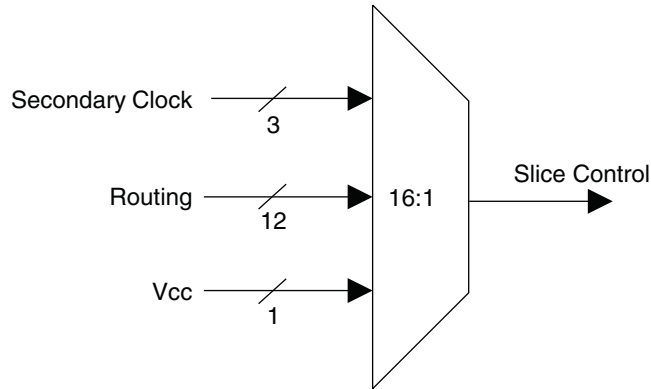

Figure 2-18. Slice0 through Slice2 Control Selection



Edge Clock Routing

LatticeECP2/M devices have a number of high-speed edge clocks that are intended for use with the PIOs in the implementation of high-speed interfaces. There are eight edge clocks per device: two edge clocks per edge. Different PLL and DLL outputs are routed to the two muxes on the left and right sides of the device. In addition, the CLKO signal (generated from the DLLDELA block) is routed to all the edge clock muxes on the left and right sides of the device. Figure 2-19 shows the selection muxes for these clocks.

Figure 2-19. Edge Clock Mux Connections

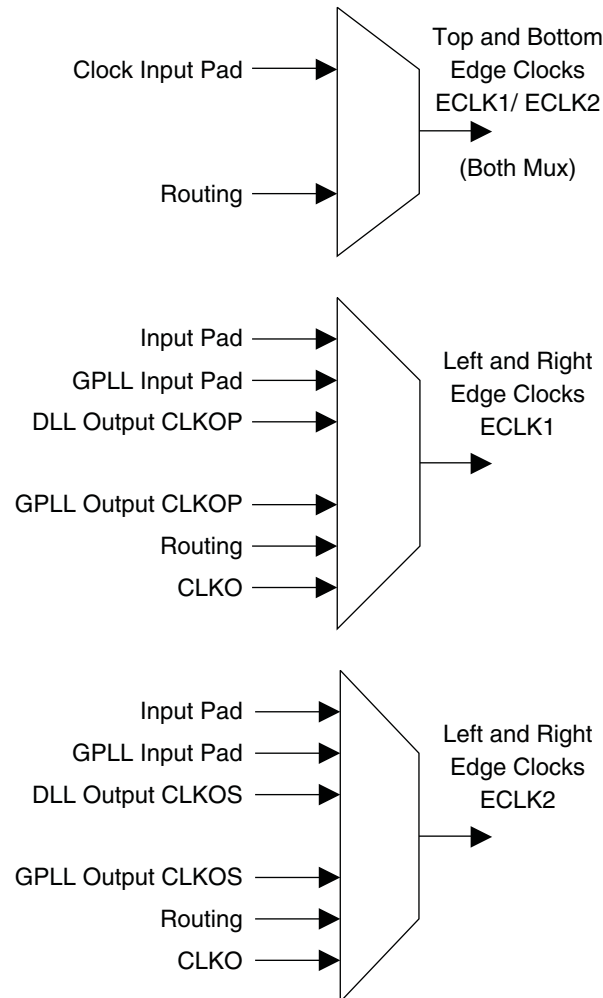

sysMEM Memory

LatticeECP2/M devices contains a number of sysMEM Embedded Block RAM (EBR). The EBR consists of an 18-Kbit RAM with dedicated input and output registers.

sysMEM Memory Block

The sysMEM block can implement single port, dual port or pseudo dual port memories. Each block can be used in a variety of depths and widths as shown in Table 2-6. FIFOs can be implemented in sysMEM EBR blocks by implementing support logic with PFUs. The EBR block facilitates parity checking by supporting an optional parity bit for each data byte. EBR blocks provide byte-enable support for configurations with 18-bit and 36-bit data widths.

Table 2-6. sysMEM Block Configurations

Memory Mode	Configurations
Single Port	16,384 x 1 8,192 x 2 4,096 x 4 2,048 x 9 1,024 x 18 512 x 36
True Dual Port	16,384 x 1 8,192 x 2 4,096 x 4 2,048 x 9 1,024 x 18
Pseudo Dual Port	16,384 x 1 8,192 x 2 4,096 x 4 2,048 x 9 1,024 x 18 512 x 36

Bus Size Matching

All of the multi-port memory modes support different widths on each of the ports. The RAM bits are mapped LSB word 0 to MSB word 0, LSB word 1 to MSB word 1, and so on. Although the word size and number of words for each port varies, this mapping scheme applies to each port.

RAM Initialization and ROM Operation

If desired, the contents of the RAM can be pre-loaded during device configuration. By preloading the RAM block during the chip configuration cycle and disabling the write controls, the sysMEM block can also be utilized as a ROM.

Memory Cascading

Larger and deeper blocks of RAM can be created using EBR sysMEM Blocks. Typically, the Lattice design tools cascade memory transparently, based on specific design inputs.

Single, Dual and Pseudo-Dual Port Modes

In all the sysMEM RAM modes the input data and address for the ports are registered at the input of the memory array. The output data of the memory is optionally registered at the output.

EBR memory supports two forms of write behavior for single port or dual port operation:

1. Normal – Data on the output appears only during a read cycle. During a write cycle, the data (at the current address) does not appear on the output. This mode is supported for all data widths.

- Write Through – A copy of the input data appears at the output of the same port during a write cycle. This mode is supported for all data widths.

Memory Core Reset

The memory array in the EBR utilizes latches at the A and B output ports. These latches can be reset asynchronously or synchronously. RSTA and RSTB are local signals, which reset the output latches associated with Port A and Port B, respectively. The Global Reset (GSRN) signal resets both ports. The output data latches and associated resets for both ports are as shown in Figure 2-20.

Figure 2-20. Memory Core Reset

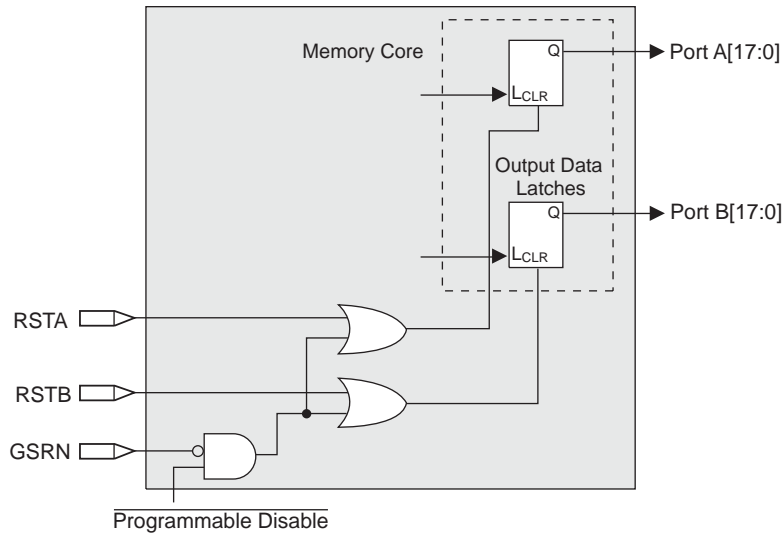

For further information about the sysMEM EBR block, please see the the list of additional technical documentation at the end of this data sheet.

EBR Asynchronous Reset

EBR asynchronous reset or GSR (if used) can only be applied if all clock enables are low for a clock cycle before the reset is applied and released a clock cycle after the reset is released, as shown in Figure 2-21. The GSR input to the EBR is always asynchronous.

Figure 2-21. EBR Asynchronous Reset (Including GSR) Timing Diagram

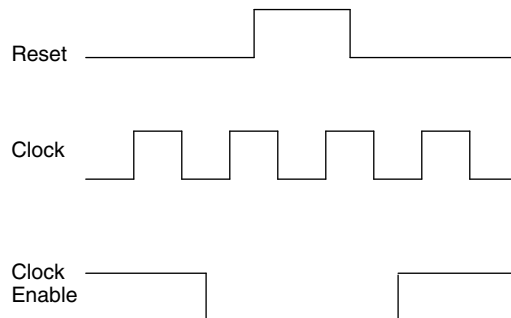

If all clock enables remain enabled, the EBR asynchronous reset or GSR may only be applied and released after the EBR read and write clock inputs are in a steady state condition for a minimum of $1/f_{MAX}$ (EBR clock). The reset release must adhere to the EBR synchronous reset setup time before the next active read or write clock edge.

If an EBR is pre-loaded during configuration, the GSR input must be disabled or the release of the GSR during device Wake Up must occur before the release of the device I/Os becomes active.

These instructions apply to all EBR RAM and ROM implementations.

Note that there are no reset restrictions if the EBR synchronous reset is used and the EBR GSR input is disabled.

sysDSP™ Block

The LatticeECP2/M family provides a sysDSP block, making it ideally suited for low cost, high performance Digital Signal Processing (DSP) applications. Typical functions used in these applications are Finite Impulse Response (FIR) filters, Fast Fourier Transforms (FFT) functions, Correlators, Reed-Solomon/Turbo/Convolution encoders and decoders. These complex signal processing functions use similar building blocks such as multiply-adders and multiply-accumulators.

sysDSP Block Approach Compared to General DSP

Conventional general-purpose DSP chips typically contain one to four (Multiply and Accumulate) MAC units with fixed data-width multipliers; this leads to limited parallelism and limited throughput. Their throughput is increased by higher clock speeds. The LatticeECP2/M, on the other hand, has many DSP blocks that support different data-widths. This allows the designer to use highly parallel implementations of DSP functions. The designer can optimize the DSP performance vs. area by choosing an appropriate level of parallelism. Figure 2-22 compares the fully serial and the mixed parallel and serial implementations.

Figure 2-22. Comparison of General DSP and LatticeECP2/M Approaches

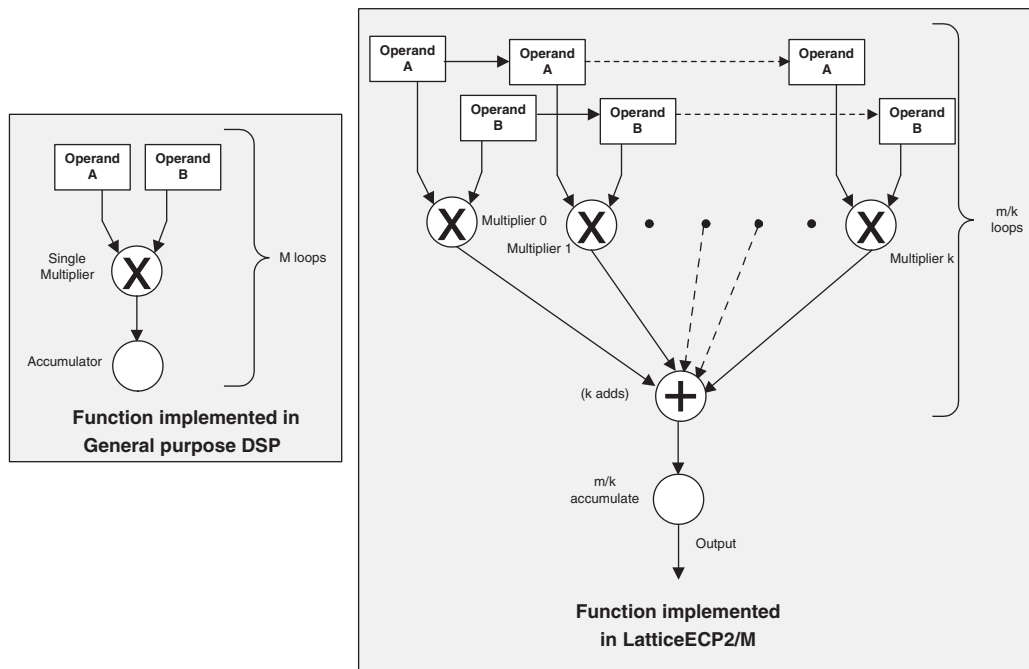

sysDSP Block Capabilities

The sysDSP block in the LatticeECP2/M family supports four functional elements in three 9, 18 and 36 data path widths. The user selects a function element for a DSP block and then selects the width and type (signed/unsigned) of its operands. The operands in the LatticeECP2/M family sysDSP Blocks can be either signed or unsigned but not mixed within a function element. Similarly, the operand widths cannot be mixed within a block. In the LatticeECP2/M family the DSP elements can be concatenated.

The resources in each sysDSP block can be configured to support the following four elements:

- MULT (Multiply)
- MAC (Multiply, Accumulate)
- MULTADDSUB (Multiply, Addition/Subtraction)
- MULTADDSUBSUM (Multiply, Addition/Subtraction, Accumulate)

The number of elements available on each block depends in the width selected from the three available options x9, x18, and x36. A number of these elements are concatenated for highly parallel implementations of DSP functions. Table 2-7 shows the capabilities of the block.

Table 2-7. Maximum Number of Elements in a Block

Width of Multiply	x9	x18	x36
MULT	8	4	1
MAC	2	2	—
MULTADDSUB	4	2	—
MULTADDSUBSUM	2	1	—

Some options are available in four elements. The input register in all the elements can be directly loaded or can be loaded as a shift register from previous operand registers. By selecting “dynamic operation” the following operations are possible:

- In the ‘Signed/Unsigned’ options the operands can be switched between signed and unsigned on every cycle.
- In the ‘Add/Sub’ option the Accumulator can be switched between addition and subtraction on every cycle.
- The loading of operands can switch between parallel and serial operations.

MULT sysDSP Element

This multiplier element implements a multiply with no addition or accumulator nodes. The two operands, A and B, are multiplied and the result is available at the output. The user can enable the input/output and pipeline registers. Figure 2-23 shows the MULT sysDSP element.

Figure 2-23. MULT sysDSP Element

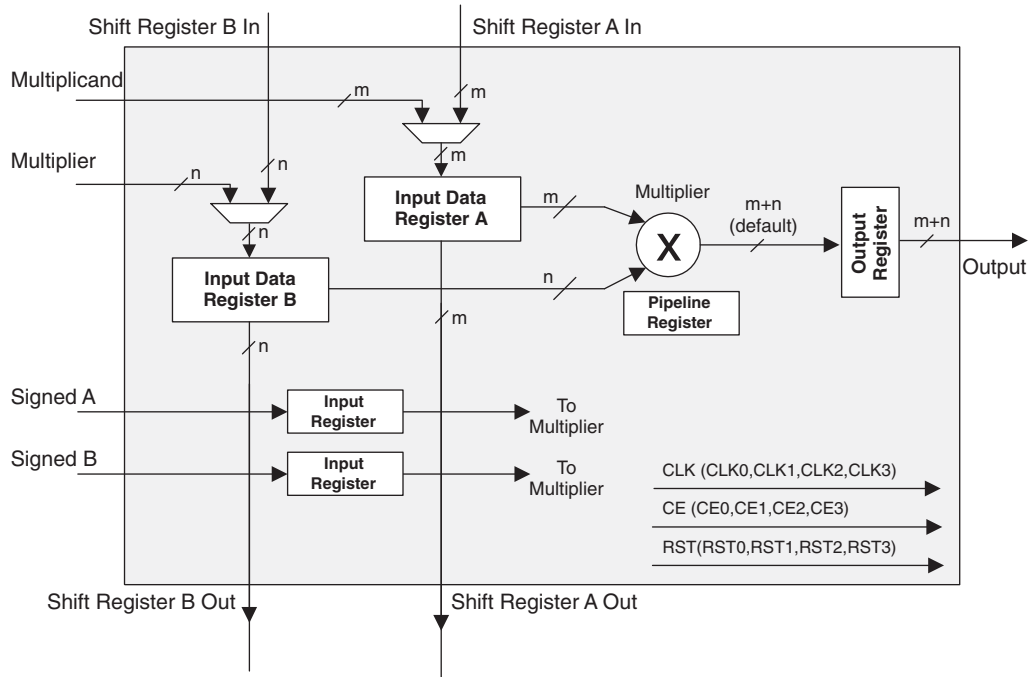

MAC sysDSP Element

In this case, the two operands, A and B, are multiplied and the result is added with the previous accumulated value. This accumulated value is available at the output. The user can enable the input and pipeline registers, but the output register is always enabled. The output register is used to store the accumulated value. The Accumulators in the DSP blocks in the LatticeECP2/M family can be initialized dynamically. A registered overflow signal is also available. The overflow conditions are provided later in this document. Figure 2-24 shows the MAC sysDSP element.

Figure 2-24. MAC sysDSP

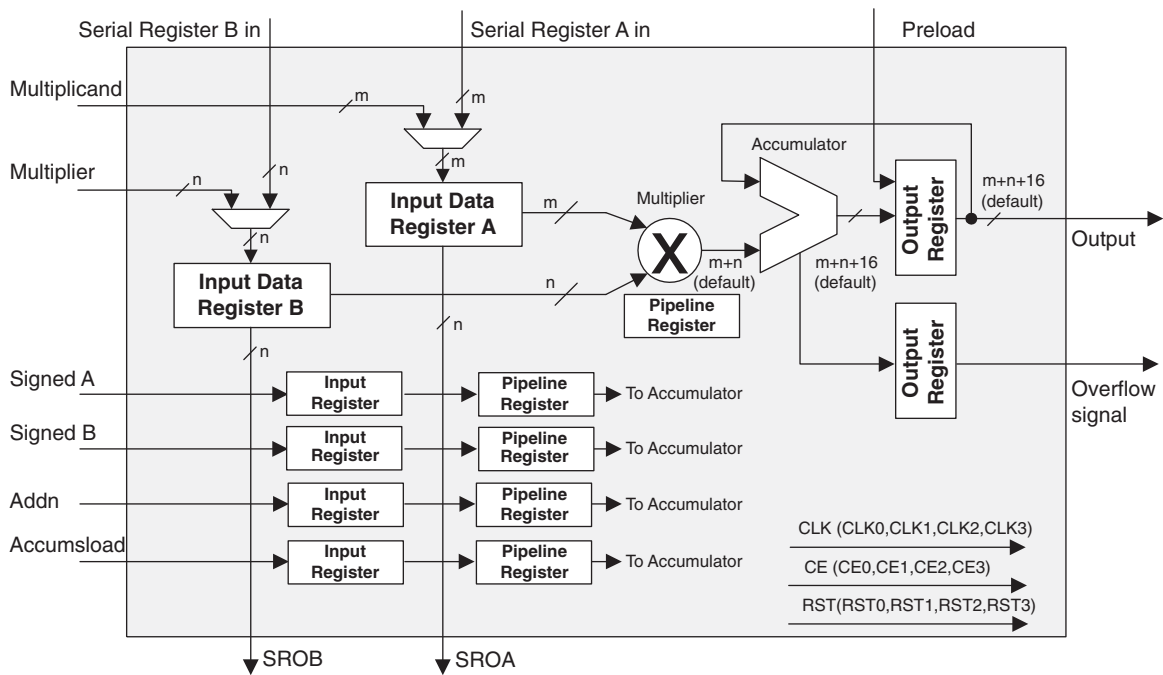

MULTADDSUB sysDSP Element

In this case, the operands A0 and B0 are multiplied and the result is added/subtracted with the result of the multiplier operation of operands A1 and A2. The user can enable the input, output and pipeline registers. Figure 2-25 shows the MULTADDSUB sysDSP element.

Figure 2-25. MULTADDSUB

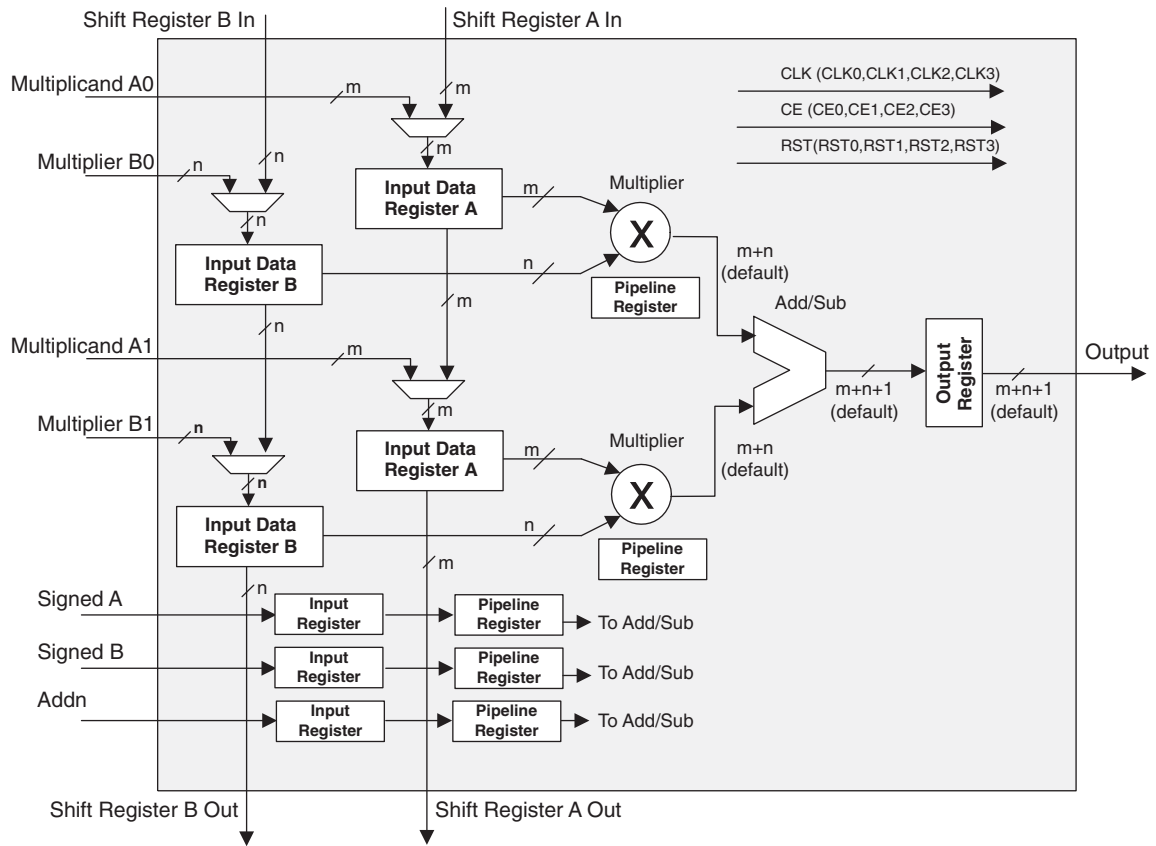

MULTADDSUBSUM sysDSP Element

In this case, the operands A0 and B0 are multiplied and the result is added/subtracted with the result of the multiplier operation of operands A1 and B1. Additionally the operands A2 and B2 are multiplied and the result is added/subtracted with the result of the multiplier operation of operands A3 and B3. The result of both addition/subtraction are added in a summation block. The user can enable the input, output and pipeline registers. Figure 2-26 shows the MULTADDSUBSUM sysDSP element.

Figure 2-26. MULTADDSUBSUM

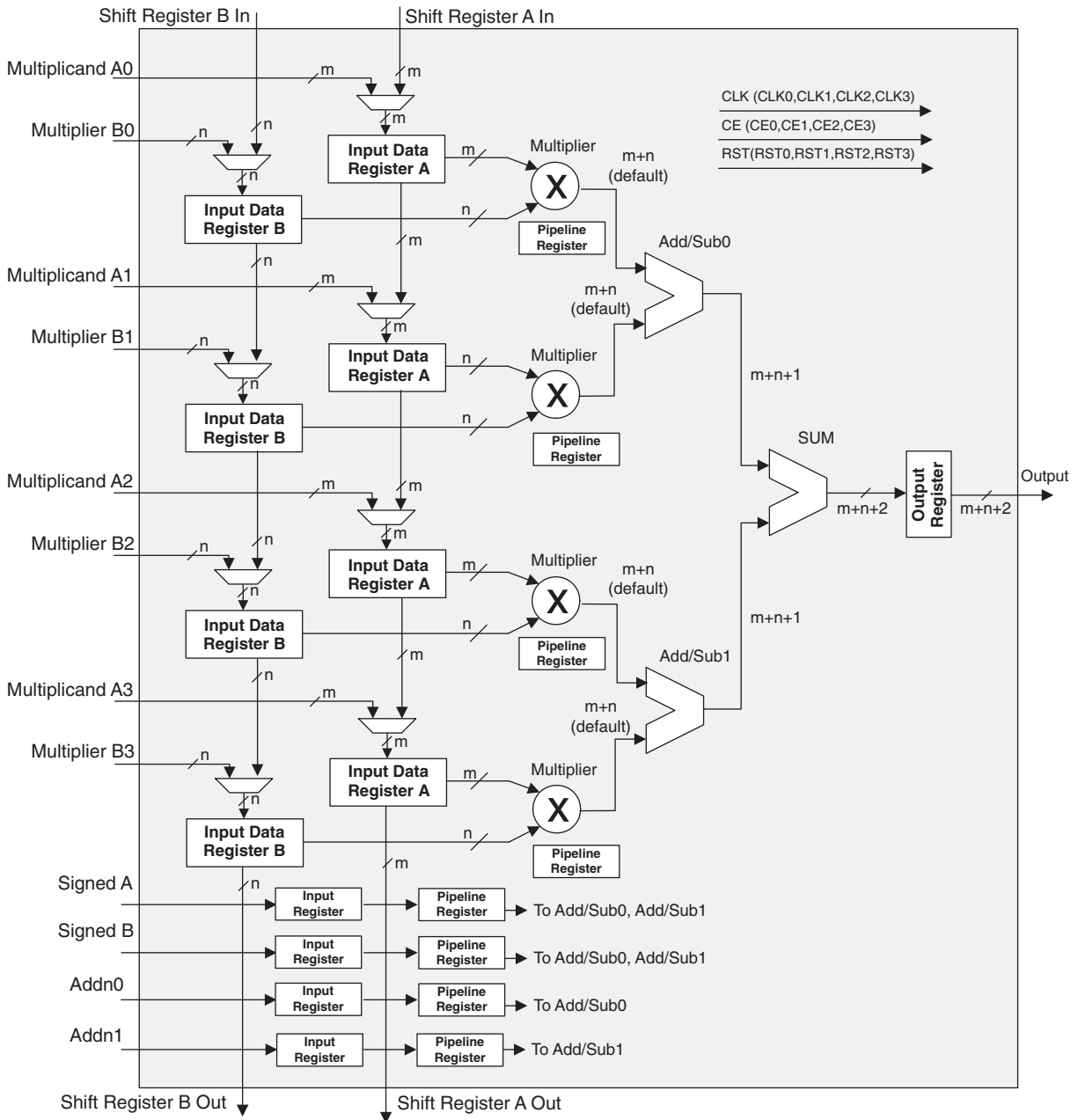

Clock, Clock Enable and Reset Resources

Global Clock, Clock Enable and Reset signals from routing are available to every DSP block. Four Clock, Reset and Clock Enable signals are selected for the sysDSP block. From four clock sources (CLK0, CLK1, CLK2, CLK3)

one clock is selected for each input register, pipeline register and output register. Similarly Clock enable (CE) and Reset (RST) are selected from their four respective sources (CE0, CE1, CE2, CE3 and RST0, RST1, RST2, RST3) at each input register, pipeline register and output register.

Signed and Unsigned with Different Widths

The DSP block supports different widths of signed and unsigned multipliers besides x9, x18 and x36 widths. For unsigned operands, unused upper data bits should be filled to create a valid x9, x18 or x36 operand. For signed two's complement operands, sign extension of the most significant bit should be performed until x9, x18 or x36 width is reached. Table 2-8 provides an example of this.

Table 2-8. Sign Extension Example

Number	Unsigned	Unsigned 9-bit	Unsigned 18-bit	Signed	Two's Complement Signed 9 Bits	Two's Complement Signed 18 Bits
+5	0101	000000101	0000000000000000101	0101	000000101	0000000000000000101
-6	N/A	N/A	N/A	1010	11111010	111111111111111010

OVERFLOW Flag from MAC

The sysDSP block provides an overflow output to indicate that the accumulator has overflowed. When two unsigned numbers are added and the result is a smaller number than the accumulator, “roll-over” is said to have occurred and an overflow signal is indicated. When two positive numbers are added with a negative sum and when two negative numbers are added with a positive sum, then the accumulator “roll-over” is said to have occurred and an overflow signal is indicated. Note that when overflow occurs the overflow flag is present for only one cycle. By counting these overflow pulses in FPGA logic, larger accumulators can be constructed. The conditions overflow signals for signed and unsigned operands are listed in Figure 2-27.

Figure 2-27. Accumulator Overflow/Underflow

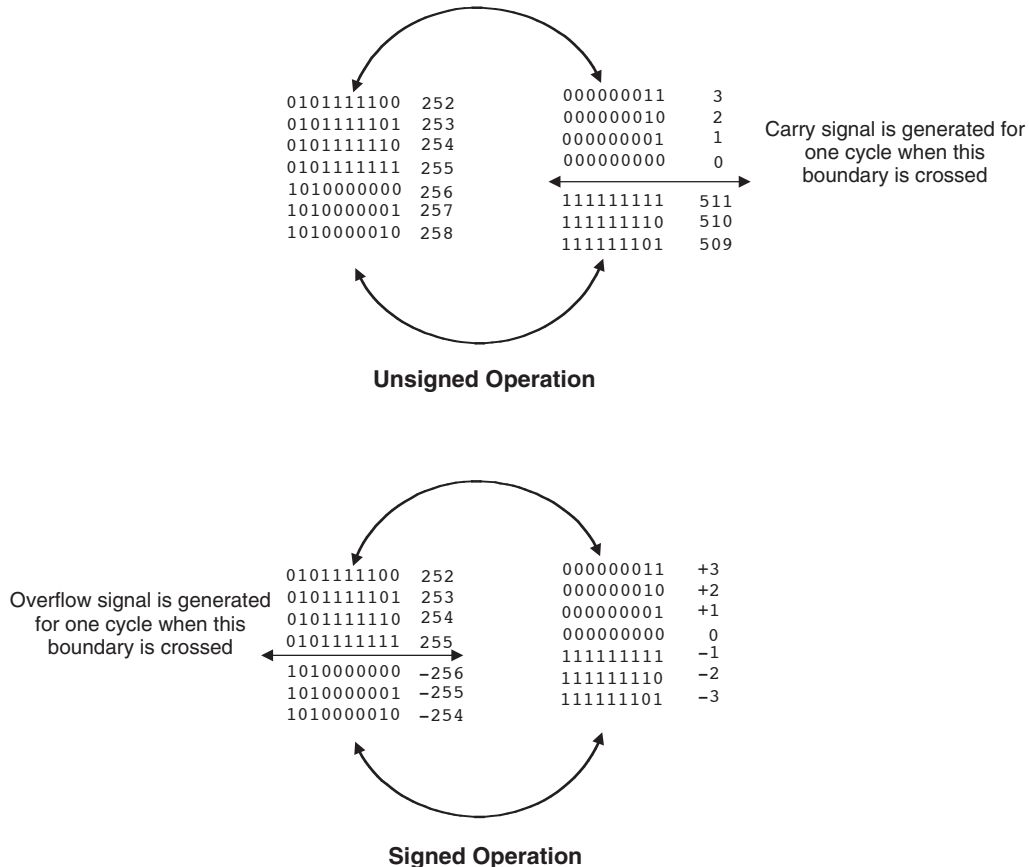

IPexpress™

The user can access the sysDSP block via the ispLEVER IPexpress tool, which provides the option to configure each DSP module (or group of modules) or by direct HDL instantiation. In addition, Lattice has partnered with The MathWorks® to support instantiation in the Simulink® tool, a graphical simulation environment. Simulink works with ispLEVER to dramatically shorten the DSP design cycle in Lattice FPGAs.

Optimized DSP Functions

Lattice provides a library of optimized DSP IP functions. Some of the IP cores planned for the LatticeECP2/M DSP include the Bit Correlator, Fast Fourier Transform, Finite Impulse Response (FIR) Filter, Reed-Solomon Encoder/Decoder, Turbo Encoder/Decoder and Convolutional Encoder/Decoder. Please contact Lattice to obtain the latest list of available DSP IP cores.

Resources Available in the LatticeECP2/M Family

Table 2-9 shows the maximum number of multipliers for each member of the LatticeECP2/M family. Table 2-10 shows the maximum available EBR RAM Blocks in each LatticeECP2/M device. EBR blocks, together with Distributed RAM can be used to store variables locally for fast DSP operations.

Table 2-9. Maximum Number of DSP Blocks in the LatticeECP2/M Family

Device	DSP Block	9x9 Multiplier	18x18 Multiplier	36x36 Multiplier
ECP2-6	3	24	12	3
ECP2-12	6	48	24	6
ECP2-20	7	56	28	7
ECP2-35	8	64	32	8
ECP2-50	18	144	72	18
ECP2-70	22	176	88	22
ECP2M20	6	48	24	6
ECP2M35	8	64	32	8
ECP2M50	22	176	88	22
ECP2M70	24	192	96	24
ECP2M100	42	336	168	42

Table 2-10. Embedded SRAM in the LatticeECP2/M Family

Device	EBR SRAM Block	Total EBR SRAM (Kbits)
ECP2-6	3	55
ECP2-12	12	221
ECP2-20	15	277
ECP2-35	18	332
ECP2-50	21	387
ECP2-70	60	1106
ECP2M20	66	1217
ECP2M35	114	2101
ECP2M50	225	4147
ECP2M70	246	4534
ECP2M100	288	5308

LatticeECP2/M DSP Performance

Table 2-11 lists the maximum performance in millions of MAC operations per second (MMAC) for each member of the LatticeECP2/M family.

Table 2-11. DSP Performance

Device	DSP Block	DSP Performance GMAC
ECP2-6	3	3.9
ECP2-12	6	7.8
ECP2-20	7	9.1
ECP2-35	8	10.4
ECP2-50	18	23.4
ECP2-70	22	28.6
ECP2M20	6	7.8
ECP2M35	8	10.4
ECP2M50	22	28.6
ECP2M70	24	31.2
ECP2M100	42	54.6

For further information about the sysDSP block, please see the list of additional technical information at the end of this data sheet.

Programmable I/O Cells (PIC)

Each PIC contains two PIOs connected to their respective sysI/O buffers as shown in Figure 2-28. The PIO Block supplies the output data (DO) and the tri-state control signal (TO) to the sysI/O buffer and receives input from the buffer. Table 2-12 provides the PIO signal list.

Figure 2-28. PIC Diagram

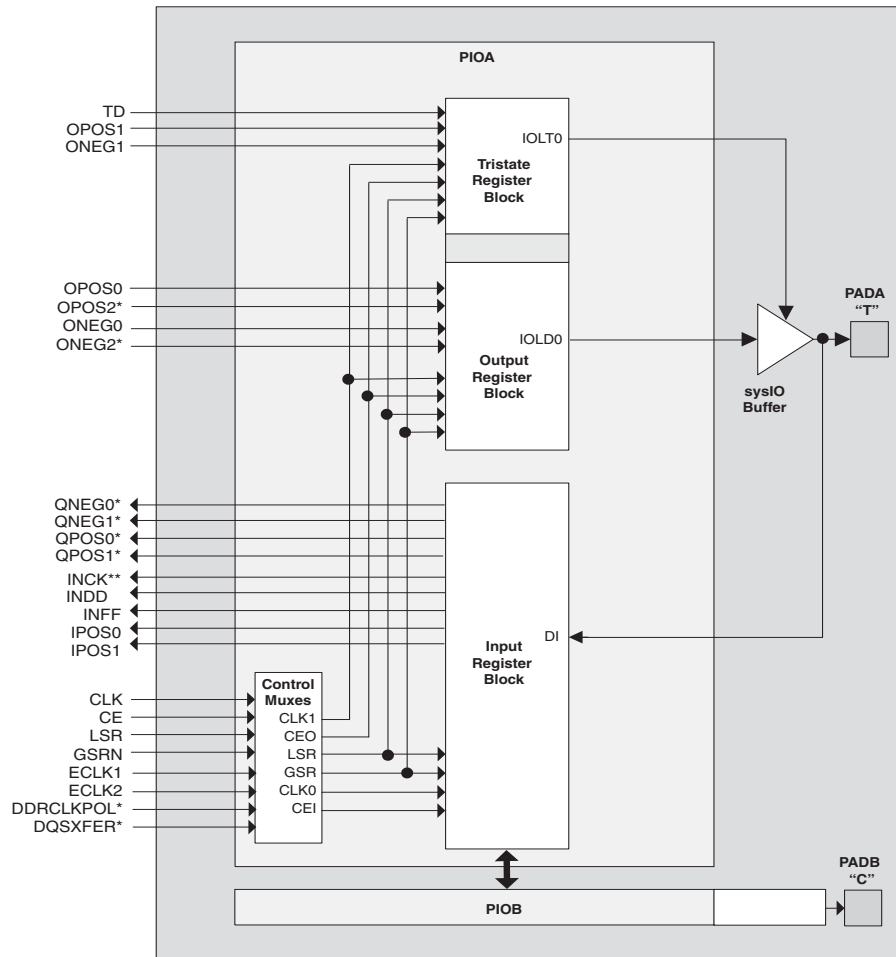

*Signals are available on left/right/bottom edges only.
** Selected blocks.

Two adjacent PIOs can be joined to provide a differential I/O pair (labeled as “T” and “C”) as shown in Figure 2-28. The PAD Labels “T” and “C” distinguish the two PIOs. Approximately 50% of the PIO pairs on the left and right edges of the device can be configured as true LVDS outputs. All I/O pairs can operate as inputs.

Table 2-12. PIO Signals List

Name	Type	Description
CE0, CE1	Control from the core	Clock enables for input and output block flip-flops
CLK0, CLK1	Control from the core	System clocks for input and output blocks
ECLK1, ECLK2	Control from the core	Fast edge clocks
LSR	Control from the core	Local Set/Reset
GSRN	Control from routing	Global Set/Reset (active low)
INCK ²	Input to the core	Input to Primary Clock Network or PLL reference inputs
DQS	Input to PIO	DQS signal from logic (routing) to PIO
INDD	Input to the core	Unregistered data input to core
INFF	Input to the core	Registered input on positive edge of the clock (CLK0)
IPOS0, IPOS1	Input to the core	Double data rate registered inputs to the core
QPOS0 ¹ , QPOS1 ¹	Input to the core	Gearbox pipelined inputs to the core
QNEG0 ¹ , QNEG1 ¹	Input to the core	Gearbox pipelined inputs to the core
OPOS0, ONEG0, OPOS2, ONEG2	Output data from the core	Output signals from the core for SDR and DDR operation
OPOS1 ONEG1	Tristate control from the core	Signals to Tristate Register block for DDR operation
DEL[3:0]	Control from the core	Dynamic input delay control bits
TD	Tristate control from the core	Tristate signal from the core used in SDR operation
DDRCLKPOL	Control from clock polarity bus	Controls the polarity of the clock (CLK0) that feed the DDR input block
DQSXFER	Control from core	Controls signal to the Output block

1. Signals available on left/right/bottom only.

2. Selected I/O.

PIO

The PIO contains four blocks: an input register block, output register block, tristate register block and a control logic block. These blocks contain registers for operating in a variety of modes along with the necessary clock and selection logic.

Input Register Block

The input register blocks for PIOs in left, right and bottom edges contain delay elements and registers that can be used to condition high-speed interface signals, such as DDR memory interfaces and source synchronous interfaces, before they are passed to the device core. Figure 2-29 shows the diagram of the input register block for left, right and bottom edges. The input register block for the top edge contains one memory element to register the input signal as shown in Figure 2-30. The following description applies to the input register block for PIOs in the left, right and bottom edges of the device.

Input signals are fed from the sysI/O buffer to the input register block (as signal DI). If desired, the input signal can bypass the register and delay elements and be used directly as a combinatorial signal (INDD), a clock (INCK) and, in selected blocks, the input to the DQS delay block. If an input delay is desired, designers can select either a fixed delay or a dynamic delay DEL[3:0]. The delay, if selected, reduces input register hold time requirements when using a global clock.

The input block allows three modes of operation. In the single data rate (SDR) the data is registered, by one of the registers in the single data rate sync register block, with the system clock. In DDR Mode, two registers are used to sample the data on the positive and negative edges of the DQS signal, creating two data streams, D0 and D1. These two data streams are synchronized with the system clock before entering the core. Further discussion on this topic is in the DDR Memory section of this data sheet.

By combining input blocks of the complementary PIOs and sharing some registers from output blocks, a gearbox function can be implemented, which takes a double data rate signal applied to PIOA and converts it as four data streams, IPOS0A, IPOS1A, IPOS0B and IPOS1B. Figure 2-29 shows the diagram using this gearbox function. For more information about this topic, please see information regarding additional documentation at the end of this data sheet.

The signal DDRCLKPOL controls the polarity of the clock used in the synchronization registers. It ensures adequate timing when data is transferred from the DQS to the system clock domain. For further information about this topic, see the DDR Memory section of this data sheet.

Figure 2-29. Input Register Block for Left, Right and Bottom Edges

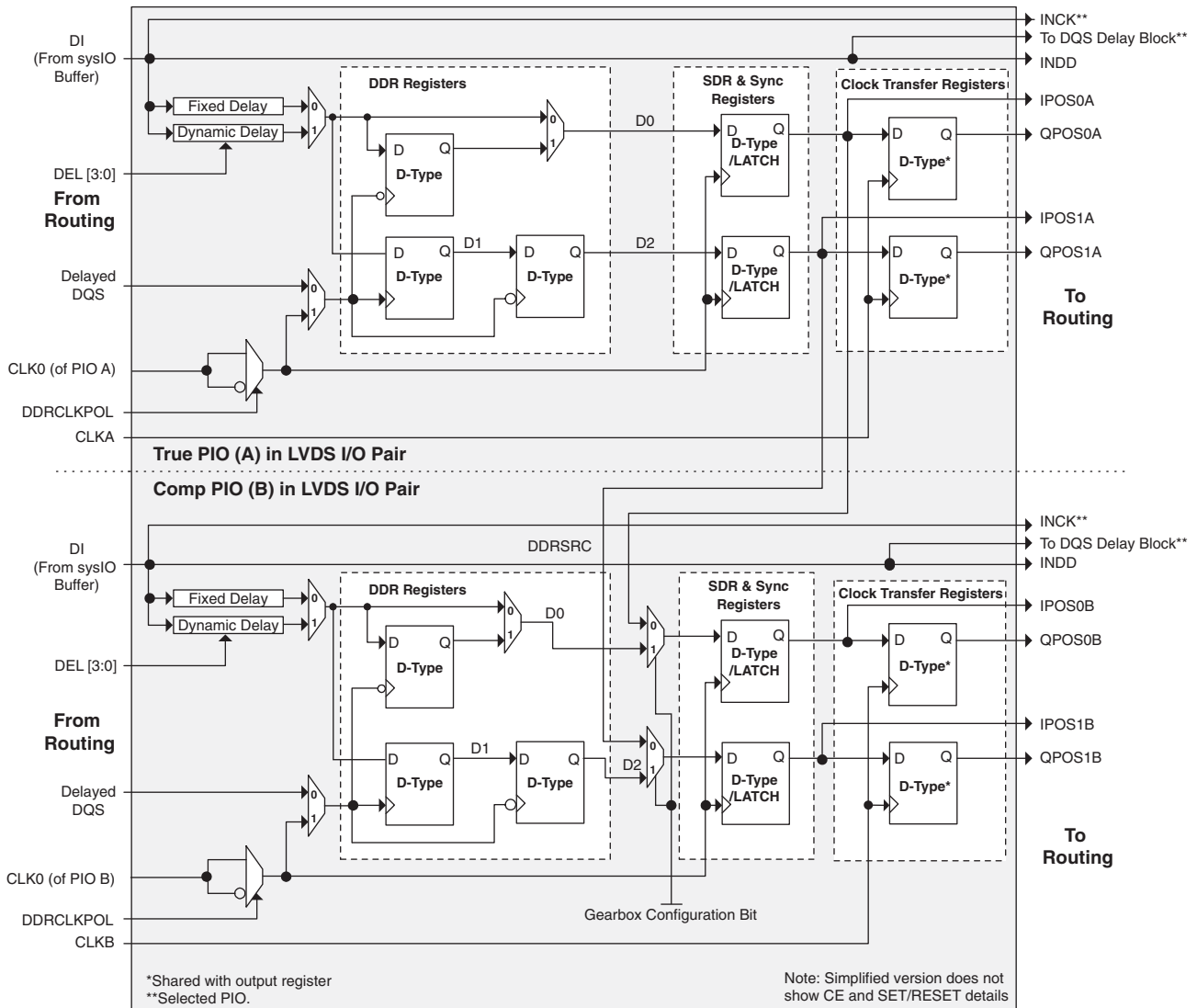
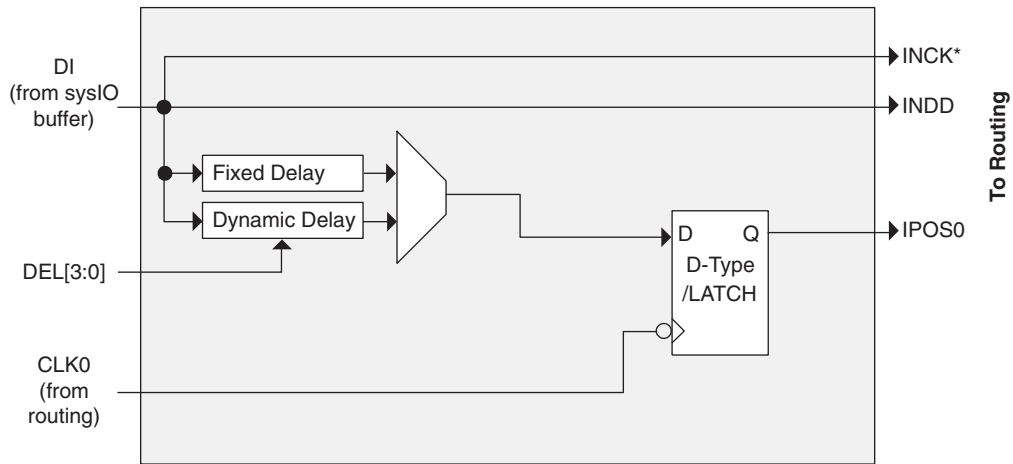

Figure 2-30. Input Register Block Top Edge



Note: Simplified version does not show CE and SET/RESET details.
*On selected blocks.

Output Register Block

The output register block provides the ability to register signals from the core of the device before they are passed to the sysI/O buffers. The blocks on the PIOs on the left, right and bottom contain a register for SDR operation that is combined with an additional latch for DDR operation. Figure 2-31 shows the diagram of the Output Register Block for PIOs on the left, right and the bottom edges. Figure 2-32 shows the diagram of the Output Register Block for PIOs on the top edge of the device.

In SDR mode, ONEG0 feeds one of the flip-flops that then feeds the output. The flip-flop can be configured as a D-type or latch. In DDR mode, ONEG0 and OPOS0 are fed into registers on the positive edge of the clock. Then at the next clock cycle this registered OPOS0 is latched. A multiplexer running off the same clock selects the correct register for feeding to the output (D0).

By combining the output blocks of the complementary PIOs and sharing some registers from input blocks, a gearbox function can be implemented, that takes four data streams: ONEG0A, ONEG1A, ONEG1B and ONEG1B. Figure 2-32 shows the diagram using this gearbox function. For more information about this topic, please see information regarding additional documentation at the end of this data sheet.

Figure 2-31. Output and Tristate Block for Left, Right and Bottom Edges

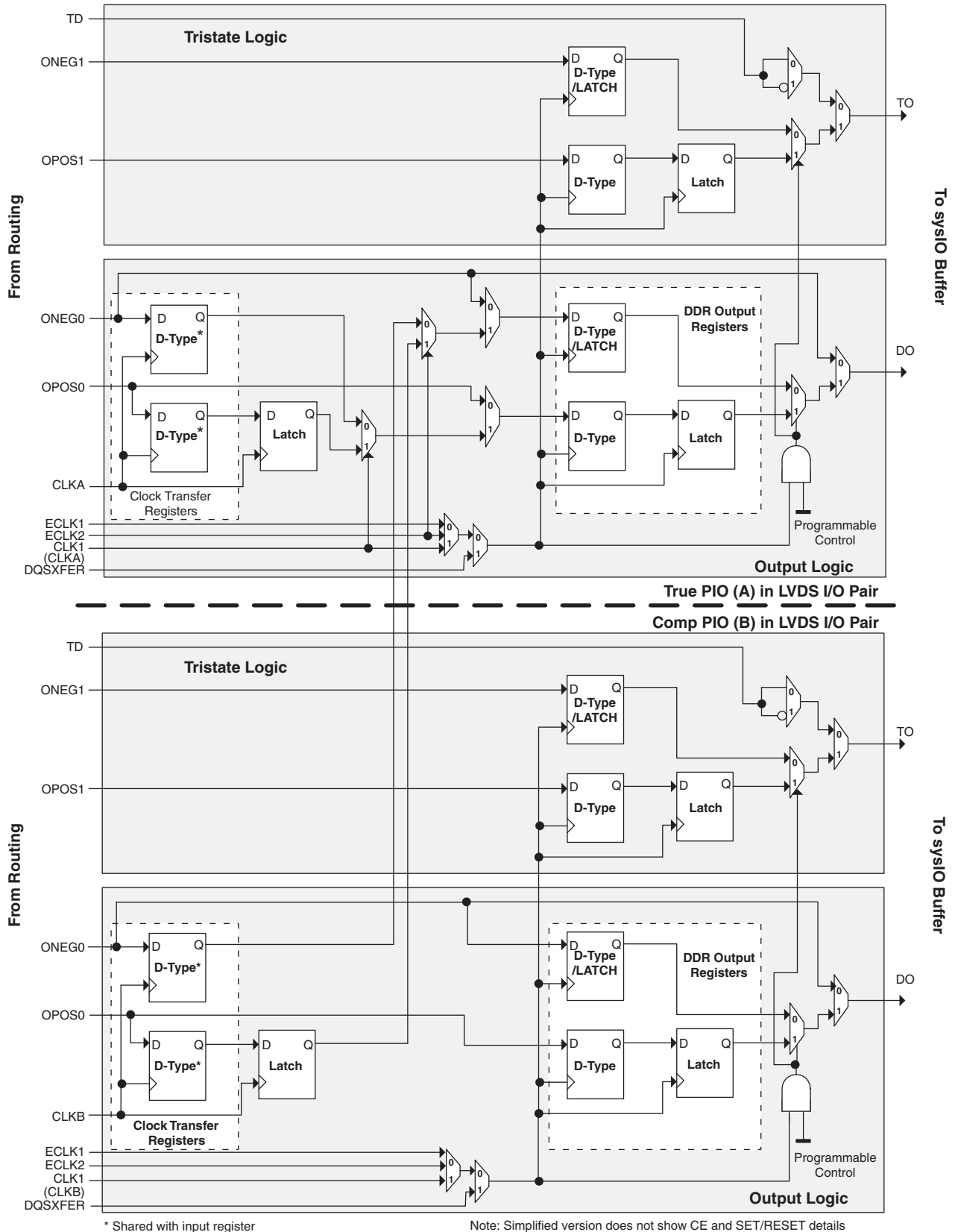

* Shared with input register

Note: Simplified version does not show CE and SET/RESET details

Figure 2-32. Output and Tristate Block, Top Edge

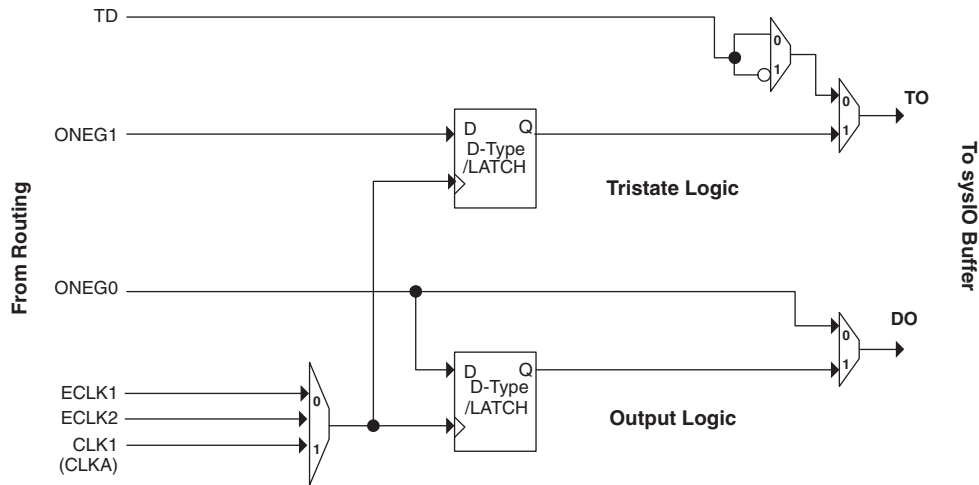

Note: Simplified version does not show CE and SET/RESET details.

Tristate Register Block

The tristate register block provides the ability to register tri-state control signals from the core of the device before they are passed to the sys/O buffers. The block contains a register for SDR operation and an additional latch for DDR operation. Figure 2-31 shows the diagram of the Tristate Register Block with the Output Block for the left, right and bottom edges and Figure 2-32 shows the diagram of the Tristate Register Block with the Output Block for the top edge.

In SDR mode, ONEG1 feeds one of the flip-flops that then feeds the output. The flip-flop can be configured a D-type or latch. In DDR mode, ONEG1 and OPOS1 are fed into registers on the positive edge of the clock. Then in the next clock the registered OPOS1 is latched. A multiplexer running off the same clock cycle selects the correct register for feeding to the output (DO).

Control Logic Block

The control logic block allows the selection and modification of control signals for use in the PIO block. A clock is selected from one of the clock signals provided from the general purpose routing, one of the edge clocks (ECLK1/ECLK2) and a DQS signal provided from the programmable DQS pin and provided to the input register block. The clock can optionally be inverted.

DDR Memory Support

Certain PICs have additional circuitry to allow the implementation of high speed source synchronous and DDR memory interfaces. The support varies by the edge of the device as detailed below.

Left and Right Edges

PICs on these edges have registered elements that support DDR memory interfaces. One of every 16 PIOs contains a delay element to facilitate the generation of DQS signals. The DQS signal feeds the DQS bus that spans the set of 16 PIOs. Figure 2-33 shows the assignment of DQS pins in each set of 16 PIOs.

Bottom Edge

PICs on the bottom edge have registered elements that support DDR memory interfaces. One of every 18 PIOs contains a delay element to facilitate the generation of DQS signals. The DQS signal feeds the DQS bus that spans the set of 18 PIOs. Figure 2-34 shows the assignment of DQS pins in each set of 18 PIOs.

Top Edge

The PICs on the top edge are different from PIOs on the left, right and bottom edges. PIOs on this edge do not have DDR registers or DQS signals.

The exact DQS pins are shown in a dual function in the Logic Signal Connections table in this data sheet. Additional detail is provided in the Signal Descriptions table. The DQS signal from the bus is used to strobe the DDR data from the memory into input register blocks. Interfaces on the left and right edges are designed for DDR memories that support 16 bits of data, whereas interfaces on the bottom are designed for memories that support 18 bits of data.

Figure 2-33. DQS Input Routing for the Left and Right Edges of the Device

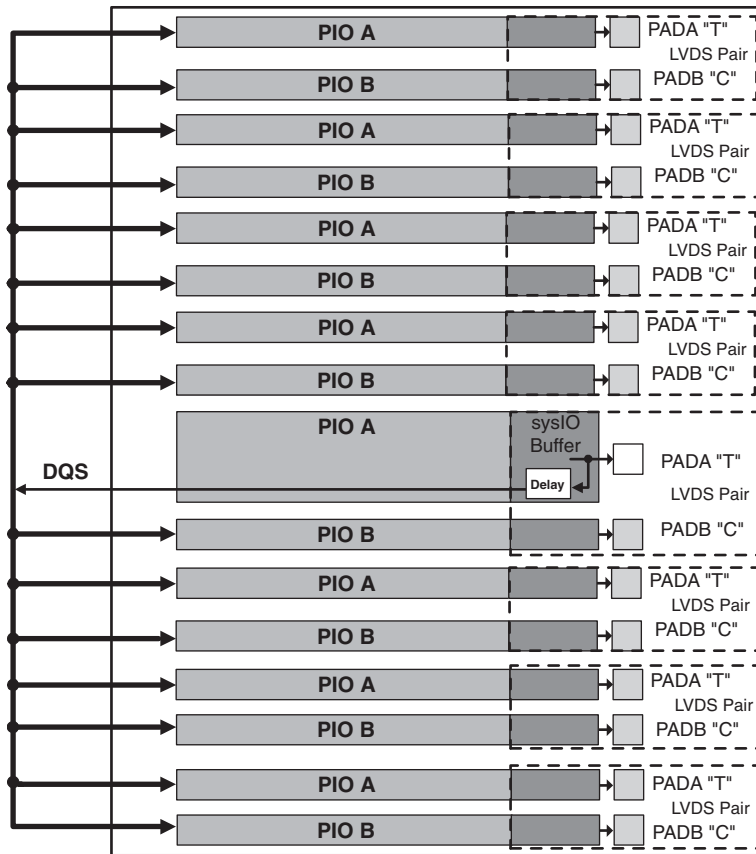
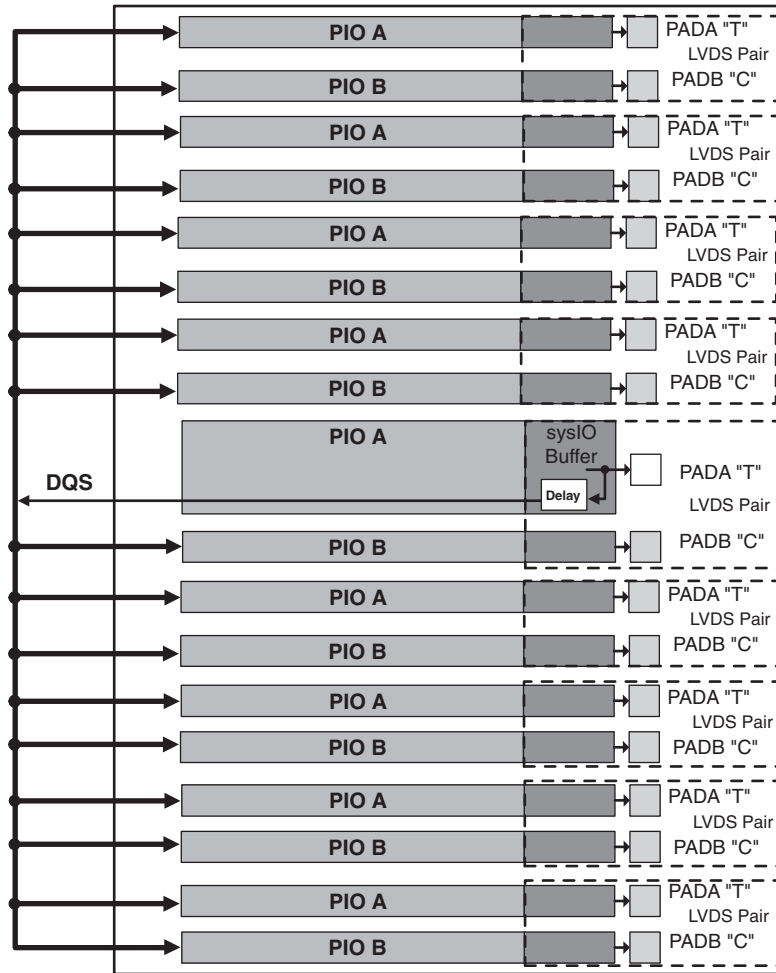

Figure 2-34. DQS Input Routing for the Bottom Edge of the Device



DLL Calibrated DQS Delay Block

Source synchronous interfaces generally require the input clock to be adjusted in order to correctly capture data at the input register. For most interfaces a PLL is used for this adjustment. However, in DDR memories the clock (referred to as DQS) is not free-running so this approach cannot be used. The DQS Delay block provides the required clock alignment for DDR memory interfaces.

The DQS signal (selected PIOs only, as shown in Figure 2-35) feeds from the PAD through a DQS delay element to a dedicated DQS routing resource. The DQS signal also feeds polarity control logic, which controls the polarity of the clock to the sync registers in the input register blocks. Figure 2-35 and Figure 2-36 show how the DQS transition signals are routed to the PIOs.

The temperature, voltage and process variations of the DQS delay block are compensated by a set of calibration (6-bit bus) signals from two dedicated DLLs (DDR_DLL) on opposite sides of the device. Each DLL compensates DQS delays in its half of the device as shown in Figure 2-35. The DLL loop is compensated for temperature, voltage and process variations by the system clock and feedback loop.

Figure 2-35. Edge Clock, DLL Calibration and DQS Local Bus Distribution

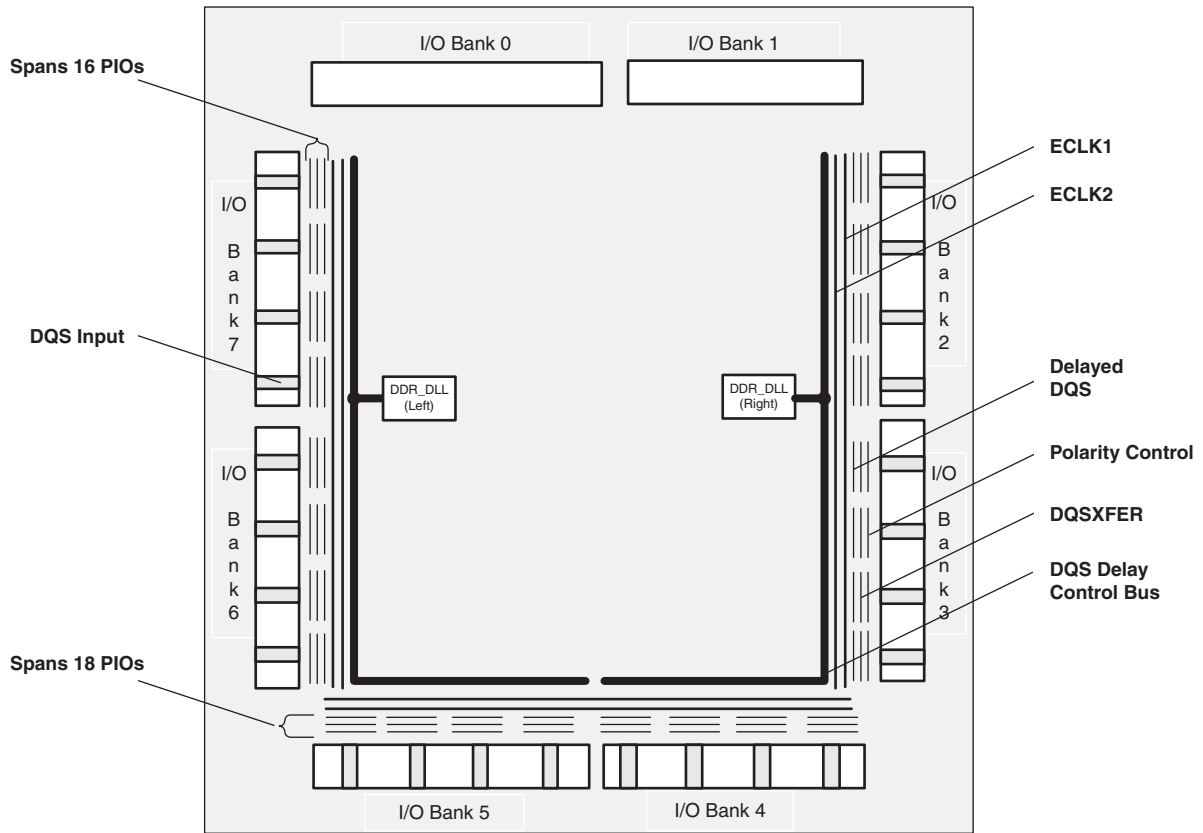

Note: Bank 8 is not shown.

Figure 2-36. DQS Local Bus

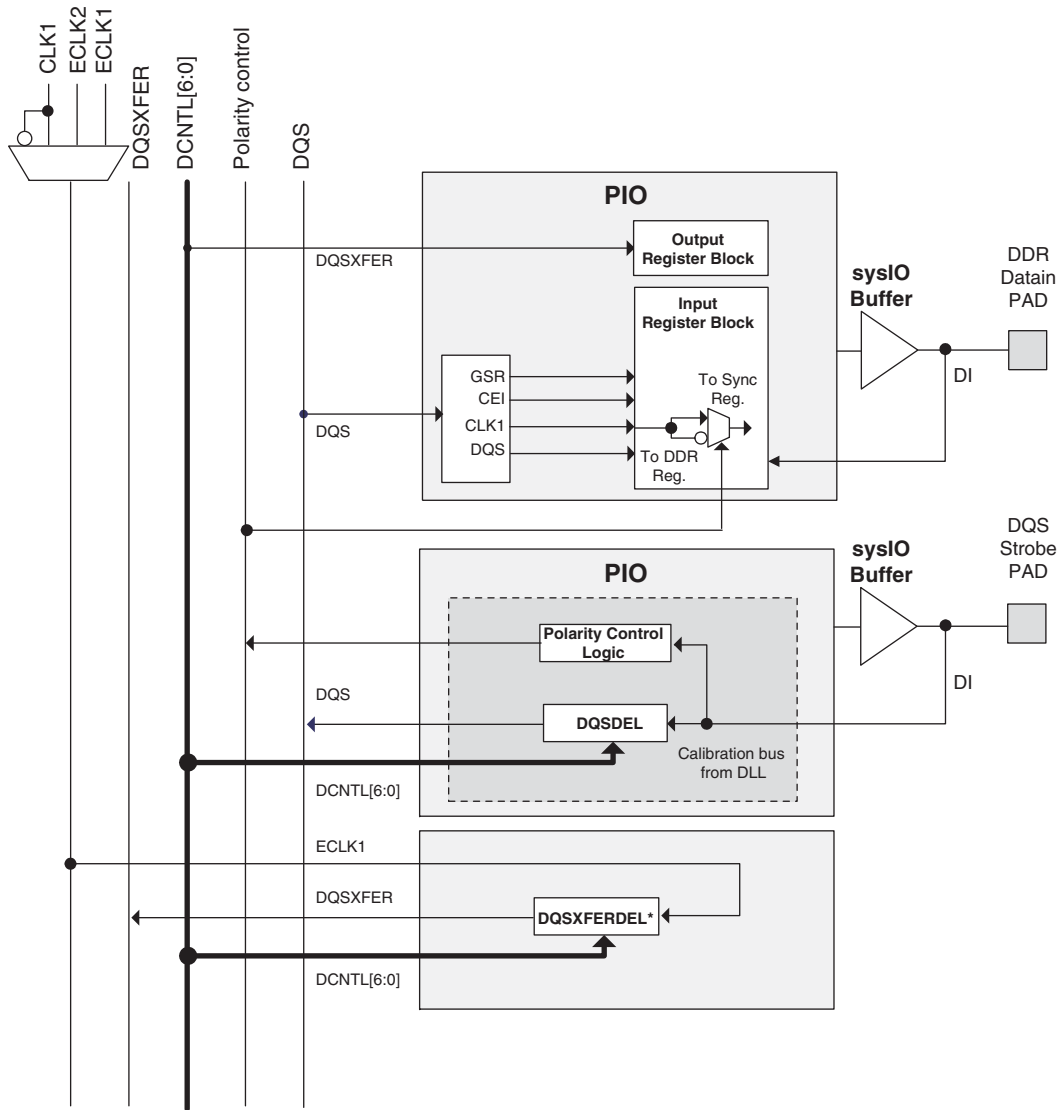

*DQSXFERDEL shifts ECLK1 by 90% and is not associated with a particular PIO.

Polarity Control Logic

In a typical DDR Memory interface design, the phase relationship between the incoming delayed DQS strobe and the internal system clock (during the READ cycle) is unknown.

The LatticeECP2/M family contains dedicated circuits to transfer data between these domains. To prevent set-up and hold violations, at the domain transfer between DQS (delayed) and the system clock, a clock polarity selector is used. This changes the edge on which the data is registered in the synchronizing registers in the input register block. This requires evaluation at the start of each READ cycle for the correct clock polarity.

Prior to the READ operation in DDR memories, DQS is in tristate (pulled by termination). The DDR memory device drives DQS low at the start of the preamble state. A dedicated circuit detects the first DQS rising edge after the preamble state. This signal is used to control the polarity of the clock to the synchronizing registers.

DQSXFER

LatticeECP2/M devices provide a DQSXFER signal to the output buffer to assist it in data transfer to DDR memories that require DQS strobe be shifted 90°. This shifted DQS strobe is generated by the DQSDEL block. The DQSXFER signal runs the span of the data bus.

sysI/O Buffer

Each I/O is associated with a flexible buffer referred to as a sysI/O buffer. These buffers are arranged around the periphery of the device in groups referred to as banks. The sysI/O buffers allow users to implement the wide variety of standards that are found in today's systems including LVCMOS, SSTL, HSTL, LVDS and LVPECL.

sysI/O Buffer Banks

LatticeECP2/M devices have nine sysI/O buffer banks: eight banks for user I/Os arranged two per side. The ninth sysI/O buffer bank (Bank 8) is located adjacent to Bank 3 and has dedicated/shared I/Os for configuration. When a shared pin is not used for configuration it is available as a user I/O. Each bank is capable of supporting multiple I/O standards. Each sysI/O bank has its own I/O supply voltage (V_{CCIO}). In addition, each bank, except Bank 8, has voltage references, V_{REF1} and V_{REF2} , which allow it to be completely independent from the others. Bank 8 shares two voltage references, V_{REF1} and V_{REF2} , with Bank 3. Figure 2-37 shows the nine banks and their associated supplies.

In LatticeECP2/M devices, single-ended output buffers and ratioed input buffers (LVTTL, LVCMOS and PCI) are powered using V_{CCIO} . LVTTL, LVCMOS33, LVCMOS25 and LVCMOS12 can also be set as fixed threshold inputs independent of V_{CCIO} .

Each bank can support up to two separate V_{REF} voltages, V_{REF1} and V_{REF2} , that set the threshold for the referenced input buffers. Some dedicated I/O pins in a bank can be configured to be a reference voltage supply pin. Each I/O is individually configurable based on the bank's supply and reference voltages.

Figure 2-37. LatticeECP2 Banks

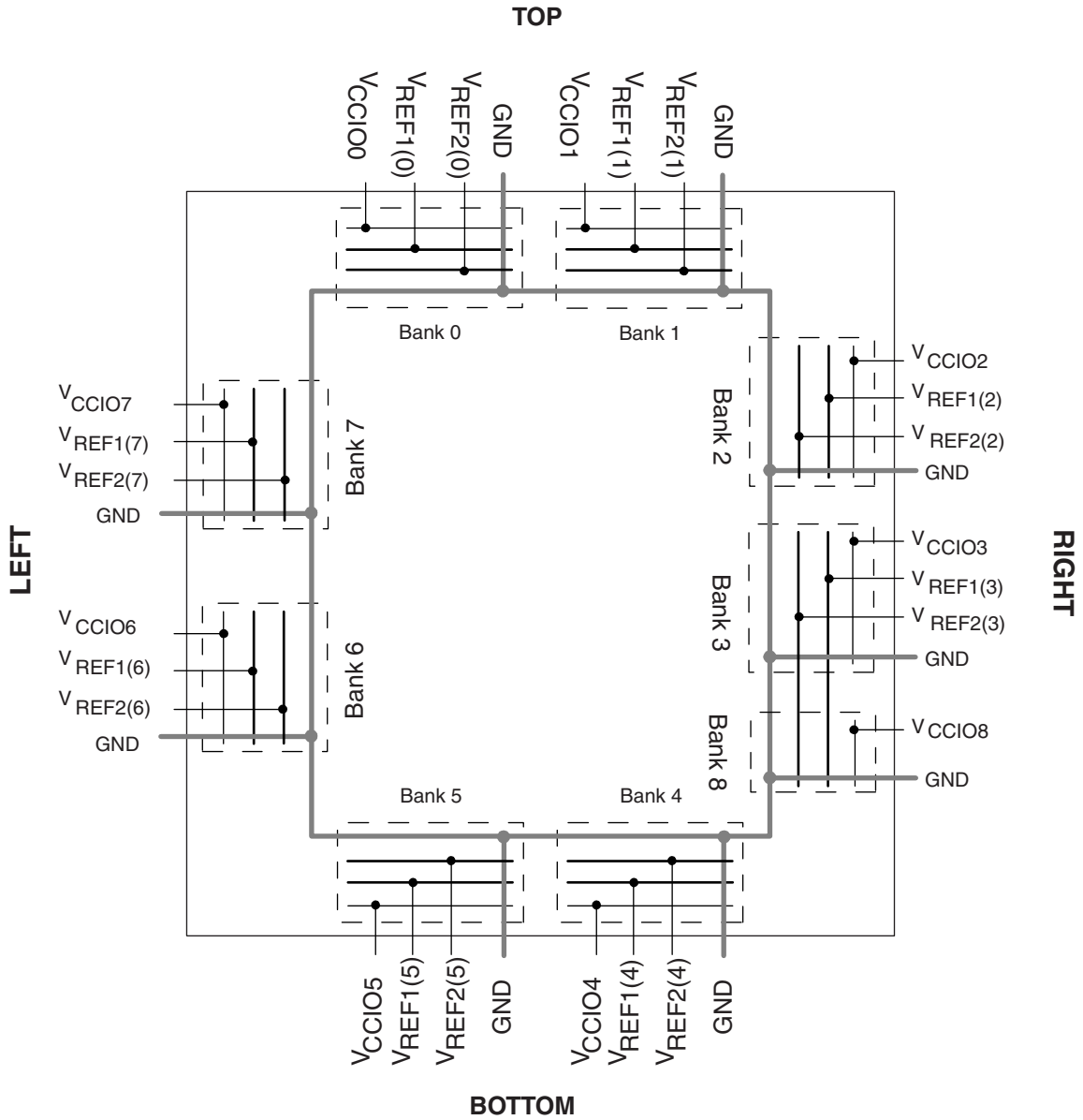
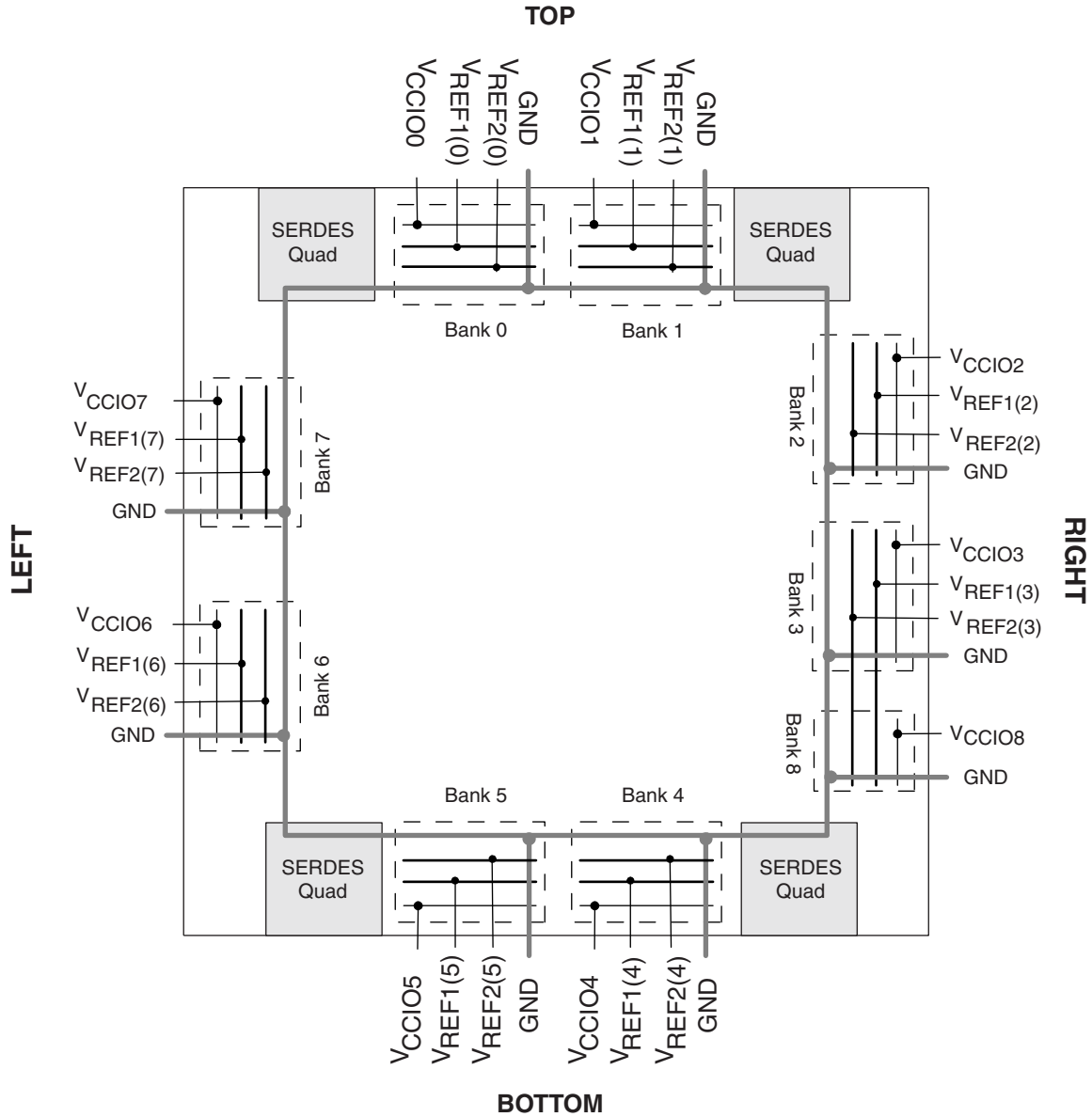

Figure 2-38. LatticeECP2M Banks



LatticeECP2/M devices contain two types of sysI/O buffer pairs.

1. **Top (Bank 0 and Bank 1) sysI/O Buffer Pairs (Single-Ended Outputs Only)**

The sysI/O buffer pairs in the top banks of the device consist of two single-ended output drivers and two sets of single-ended input buffers (both ratioed and referenced). One of the referenced input buffers can also be configured as a differential input.

The two pads in the pair are described as “true” and “comp”, where the true pad is associated with the positive side of the differential input buffer and the comp (complementary) pad is associated with the negative side of the differential input buffer.

2. **Bottom (Bank 4 and Bank 5) sysI/O Buffer Pairs (Single-Ended Outputs Only)**

The sysI/O buffer pairs in the bottom banks of the device consist of two single-ended output drivers and two

sets of single-ended input buffers (both ratioed and referenced). One of the referenced input buffers can also be configured as a differential input.

The two pads in the pair are described as “true” and “comp”, where the true pad is associated with the positive side of the differential input buffer and the comp (complementary) pad is associated with the negative side of the differential input buffer.

3. Left and Right (Banks 2, 3, 6 and 7) sysI/O Buffer Pairs (50% Differential and 100% Single-Ended Outputs)

The sysI/O buffer pairs in the left and right banks of the device consist of two single-ended output drivers, two sets of single-ended input buffers (both ratioed and referenced) and one differential output driver. One of the referenced input buffers can also be configured as a differential input. In these banks the two pads in the pair are described as “true” and “comp”, where the true pad is associated with the positive side of the differential I/O, and the comp (complementary) pad is associated with the negative side of the differential I/O.

LVDS differential output drivers are available on 50% of the buffer pairs on the left and right banks.

4. Bank 8 sysI/O Buffer Pairs (Single-Ended Outputs, Only on Shared Pins When Not Used by Configuration)

The sysI/O buffers in Bank 8 consist of single-ended output drivers and single-ended input buffers (both ratioed and referenced). The referenced input buffer can also be configured as a differential input.

The two pads in the pair are described as “true” and “comp”, where the true pad is associated with the positive side of the differential input buffer and the comp (complementary) pad is associated with the negative side of the differential input buffer.

In LatticeECP2 devices, only the I/Os on the bottom banks have programmable PCI clamps. In LatticeECP2M devices, the I/Os on the left and bottom banks have programmable PCI clamps.

Typical sysI/O I/O Behavior During Power-up

The internal power-on-reset (POR) signal is deactivated when V_{CC} , V_{CCIO8} and V_{CCAUX} have reached satisfactory levels. After the POR signal is deactivated, the FPGA core logic becomes active. It is the user's responsibility to ensure that all other V_{CCIO} banks are active with valid input logic levels to properly control the output logic states of all the I/O banks that are critical to the application. For more information about controlling the output logic state with valid input logic levels during power-up in LatticeECP2/M devices, see the list of additional technical documentation at the end of this data sheet.

The V_{CC} and V_{CCAUX} supply the power to the FPGA core fabric, whereas the V_{CCIO} supplies power to the I/O buffers. In order to simplify system design while providing consistent and predictable I/O behavior, it is recommended that the I/O buffers be powered-up prior to the FPGA core fabric. V_{CCIO} supplies should be powered-up before or together with the V_{CC} and V_{CCAUX} supplies.

Supported sysI/O Standards

The LatticeECP2/M sysI/O buffer supports both single-ended and differential standards. Single-ended standards can be further subdivided into LVCMOS, LVTTTL and other standards. The buffers support the LVTTTL, LVCMOS 1.2V, 1.5V, 1.8V, 2.5V and 3.3V standards. In the LVCMOS and LVTTTL modes, the buffer has individual configuration options for drive strength, bus maintenance (weak pull-up, weak pull-down, or a bus-keeper latch) and open drain. Other single-ended standards supported include SSTL and HSTL. Differential standards supported include LVDS, MLVDS, BLVDS, LVPECL, RSDS, differential SSTL and differential HSTL. Tables 2-13 and 2-14 show the I/O standards (together with their supply and reference voltages) supported by LatticeECP2/M devices. For further information about utilizing the sysI/O buffer to support a variety of standards please see the the list of additional technical information at the end of this data sheet.

Table 2-13. Supported Input Standards

Input Standard	V _{REF} (Nom.)	V _{CCIO} ¹ (Nom.)
Single Ended Interfaces		
LVTTTL	—	—
LVCMOS33	—	—
LVCMOS25	—	—
LVCMOS18	—	1.8
LVCMOS15	—	1.5
LVCMOS12	—	—
PCI 33	—	3.3
HSTL18 Class I, II	0.9	—
HSTL15 Class I	0.75	—
SSTL3 Class I, II	1.5	—
SSTL2 Class I, II	1.25	—
SSTL18 Class I, II	0.9	—
Differential Interfaces		
Differential SSTL18 Class I, II	—	—
Differential SSTL2 Class I, II	—	—
Differential SSTL3 Class I, II	—	—
Differential HSTL15 Class I	—	—
Differential HSTL18 Class I, II	—	—
LVDS, MLVDS, LVPECL, BLVDS, RSDS	—	—

¹ When not specified, V_{CCIO} can be set anywhere in the valid operating range (page 3-1).

Table 2-14. Supported Output Standards

Output Standard	Drive	V _{CCIO} (Nom.)
Single-ended Interfaces		
LVTTTL	4mA, 8mA, 12mA, 16mA, 20mA	3.3
LVC MOS33	4mA, 8mA, 12mA 16mA, 20mA	3.3
LVC MOS25	4mA, 8mA, 12mA, 16mA, 20mA	2.5
LVC MOS18	4mA, 8mA, 12mA, 16mA	1.8
LVC MOS15	4mA, 8mA	1.5
LVC MOS12	2mA, 6mA	1.2
LVC MOS33, Open Drain	4mA, 8mA, 12mA 16mA, 20mA	—
LVC MOS25, Open Drain	4mA, 8mA, 12mA 16mA, 20mA	—
LVC MOS18, Open Drain	4mA, 8mA, 12mA 16mA	—
LVC MOS15, Open Drain	4mA, 8mA	—
LVC MOS12, Open Drain	2mA, 6mA	—
PCI33	N/A	3.3
HSTL18 Class I, II	N/A	1.8
HSTL15 Class I	N/A	1.5
SSTL3 Class I, II	N/A	3.3
SSTL2 Class I, II	N/A	2.5
SSTL18 Class I, II	N/A	1.8
Differential Interfaces		
Differential SSTL3, Class I, II	N/A	3.3
Differential SSTL2, Class I, II	N/A	2.5
Differential SSTL18, Class I, II	N/A	1.8
Differential HSTL18, Class I, II	N/A	1.8
Differential HSTL15, Class I	N/A	1.5
LVDS	N/A	2.5
MLVDS ¹	N/A	2.5
BLVDS ¹	N/A	2.5
LVPECL ¹	N/A	3.3
RSDS ¹	N/A	2.5
LVC MOS33D ¹	4mA, 8mA, 12mA, 16mA, 20mA	3.3

1. Emulated with external resistors. For more detail, please see information regarding additional technical documentation at the end of this data sheet.

Hot Socketing

LatticeECP2/M devices have been carefully designed to ensure predictable behavior during power-up and power-down. During power-up and power-down sequences, the I/Os remain in tri-state until the power supply voltage is high enough to ensure reliable operation. In addition, leakage into I/O pins is controlled within specified limits. This allows for easy integration with the rest of the system. These capabilities make the LatticeECP2/M ideal for many multiple power supply and hot-swap applications.

SERDES and PCS (Physical Coding Sublayer)

LatticeECP2M devices feature up to 16 channels of embedded SERDES arranged in quads at the corners of the devices. Figure 2-39 shows the position of the quad blocks in relation to the PFU array for LatticeECP2M70 and LatticeECP2M100 devices. Table 2-15 shows the location of Quads for all the devices.

Each quad contains four dedicated SERDES (Ch0 to Ch3) for high-speed, full-duplex serial data transfer. Each quad also has a PCS block that interfaces to the SERDES channels and contains digital logic to support an array of popular data protocols. PCS also contains logic to the interface to FPGA core.

Figure 2-39. SERDES Quads (LatticeECP2M70/LatticeECP2M100)

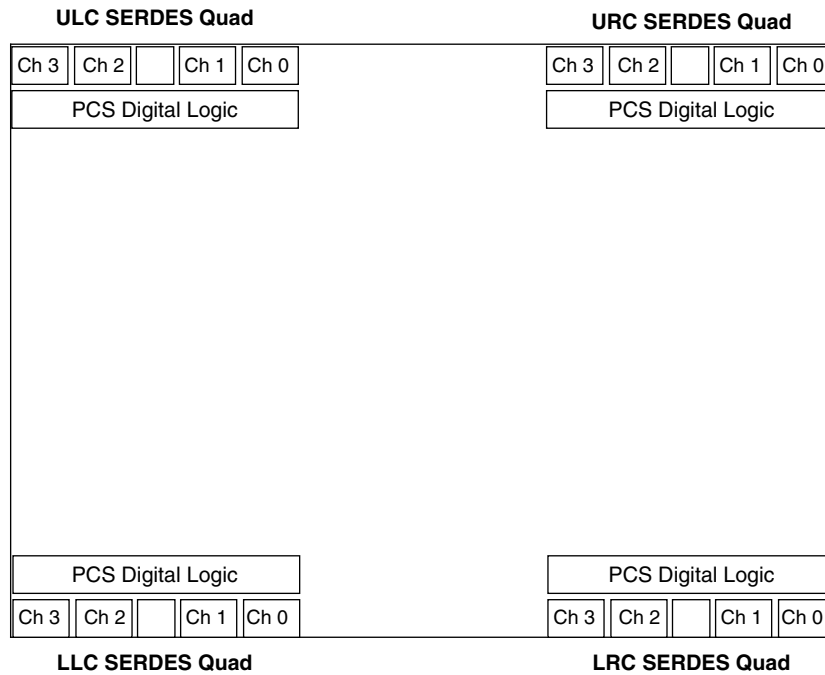

Table 2-15. Available SERDES Quads per LatticeECP2M Devices

Device	URC Quad	ULC Quad	LRC Quad	LLC Quad
ECP2M20	Available	—	—	—
ECP2M35	Available	—	—	—
ECP2M50	Available	—	Available	—
ECP2M70	Available	Available	Available	Available
ECP2M100	Available	Available	Available	Available

SERDES Block

A differential receiver receives the serial encoded data stream, equalizes the signal, extracts the buried clock and de-serializes the data-stream before passing the 8- or 10-bit data to the PCS logic. The transmit channel receives the parallel (8- or 10-bit) encoded data, serializes the data and transmits the serial bit stream through the differential buffers. There is a single transmit clock per quad. Figure 2-40 shows a single channel SERDES and its interface to the PCS logic. Each SERDES receiver channel provides a recovered clock to the PCS block and to the FPGA core logic.

Each Transmit and Receive channel has its independent power supplies. The Output and Input buffers of each channel also have their own independent power supplies. In addition, there are separate power supplies for PLL, terminating resistor per quad.

Figure 2-40. Simplified Channel Block Diagram for SERDES and PCS

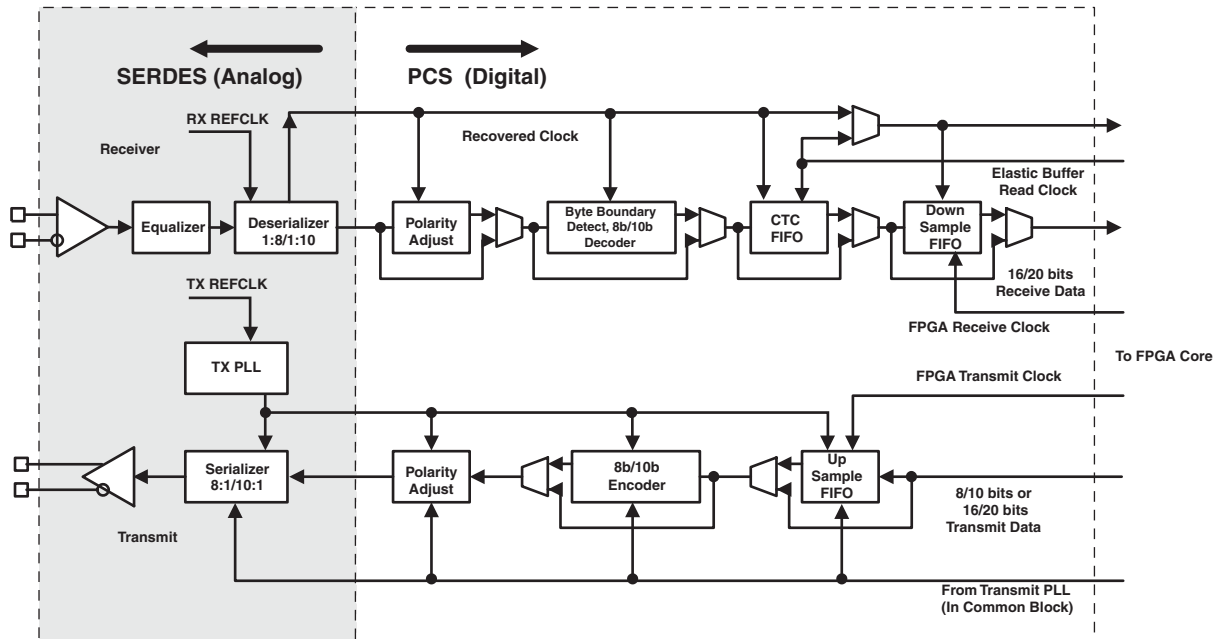

PCS

As shown in Figure 2-40, the PCS receives the parallel digital data from the deserializer receivers and adjusts the polarity, detects, byte boundary, decodes (8b/10b) and provides Clock Tolerance Compensation (CTC) FIFO for changing the clock domain from receiver clock to the FPGA Clock.

For the transmit channel, the PCS block receives the parallel data from the FPGA core, encodes it with 8b/10b, adjusts the polarity and passes the 8/10 bit data to the transmit SERDES channel.

The PCS also provides bypass modes that allow a direct 8-bit or 10-bit interface from the SERDES to the FPGA logic. The PCS interface to FPGA can also be programmed to run at 1/2 speed for a 16-bit or 20-bit interface to the FPGA logic.

SCI (SERDES Client Interface) Bus

The SERDES Client Interface (SCI) is a soft IP interface that allow the SERDES/PCS Quad block to be controlled by registers as opposed to the configuration memory cells. It is a simple register configuration interface.

The ispLEVER design tools from Lattice support all modes of the PCS. Most modes are dedicated to applications associated with a specific industry standard data protocol. Other more general purpose modes allow users to define their own operation. With ispLEVER, the user can define the mode for each quad in a design.

Popular standards such as 10Gb Ethernet and x4 PCI-Express and 4x Serial RapidIO can be implemented using IP (provided by Lattice), a single quad (Four SERDES channels and PCS) and some additional logic from the core.

For further information about SERDES, please see the list of additional technical documentation at the end of this data sheet.

IEEE 1149.1-Compliant Boundary Scan Testability

All LatticeECP2/M devices have boundary scan cells that are accessed through an IEEE 1149.1 compliant Test Access Port (TAP). This allows functional testing of the circuit board, on which the device is mounted, through a serial scan path that can access all critical logic nodes. Internal registers are linked internally, allowing test data to be shifted in and loaded directly onto test nodes, or test data to be captured and shifted out for verification. The test access port consists of dedicated I/Os: TDI, TDO, TCK and TMS. The test access port has its own supply voltage V_{CCJ} and can operate with LVCMOS3.3, 2.5, 1.8, 1.5 and 1.2 standards.

For more details on boundary scan test, please see information regarding additional technical documentation at the end of this data sheet.

Device Configuration

All LatticeECP2/M devices contain two ports that can be used for device configuration. The Test Access Port (TAP), which supports bit-wide configuration, and the sysCONFIG port, support both byte-wide and serial configuration, including the standard SPI Flash interface. The TAP supports both the IEEE Standard 1149.1 Boundary Scan specification and the IEEE Standard 1532 In-System Configuration specification. The sysCONFIG port is a 20-pin interface with six I/Os used as dedicated pins with the remainder used as dual-use pins. See Lattice technical note number TN1108, *LatticeECP2 sysCONFIG Usage Guide* for more information about using the dual-use pins as general purpose I/Os.

On power-up, the FPGA SRAM is ready to be configured using the selected sysCONFIG port. Once a configuration port is selected, it will remain active throughout that configuration cycle. The IEEE 1149.1 port can be activated any time after power-up by sending the appropriate command through the TAP port.

Enhanced Configuration Option

LatticeECP2/M devices have enhanced configuration features such as: decryption support, TransFR™ I/O and dual boot image support.

1. Decryption Support

LatticeECP2/M devices provide on-chip, One Time Programmable (OTP) non-volatile key storage to support decryption of a 128-bit AES encrypted bitstream, securing designs and deterring design piracy.

2. TransFR (Transparent Field Reconfiguration)

TransFR I/O (TFR) is a unique Lattice technology that allows users to update their logic in the field without interrupting system operation using a single ispVM® command. TransFR I/O allows I/O states to be frozen during device configuration. This allows the device to be field updated with a minimum of system disruption and downtime. See Lattice technical note number TN1087, *Minimizing System Interruption During Configuration Using TransFR Technology*, for details.

3. Dual Boot Image Support

Dual boot images are supported for applications requiring reliable remote updates of configuration data for the system FPGA. After the system is running with a basic configuration, a new boot image can be downloaded remotely and stored in a separate location in the configuration storage device. Any time after the update the LatticeECP2/M can be re-booted from this new configuration file. If there is a problem, such as corrupt data during download or incorrect version number with this new boot image, the LatticeECP2/M device can revert back to the original backup configuration and try again. This all can be done without power cycling the system.

For more information about device configuration, please see the list of additional technical documentation at the end of this data sheet.

Software Error Detect (SED) Support

LatticeECP2/M devices have dedicated logic to perform CRC checks. During configuration, the configuration data bitstream can be checked with the CRC logic block. In addition, the LatticeECP2 device can also be programmed

for checking soft errors (SED) in SRAM. This SED operation can be run in the background during user mode. If a soft error occurs, during user mode (normal operation) the device can be programmed to either reload from a known good boot image or generate an error signal.

For further information about Soft Error Detect (SED) support, please see the list of additional technical documentation at the end of this data sheet.

External Resistor

LatticeECP2/M devices require a single external, 10K ohm $\pm 1\%$ value between the XRES pin and ground. Device configuration will not be completed if this resistor is missing. There is no boundary scan register on the external resistor pad.

On-Chip Oscillator

Every LatticeECP2/M device has an internal CMOS oscillator which is used to derive a Master Clock for configuration. The oscillator and the Master Clock run continuously and are available to user logic after configuration is completed. The software default value of the Master Clock is 2.5MHz. Table 2-16 lists all the available Master Configuration Clock frequencies for normal non-encrypted mode and encrypted mode. When a different Master Clock is selected during the design process, the following sequence takes place:

1. Device powers up with a Master Clock frequency of 3.1MHz.
2. During configuration, users select a different master clock frequency.
3. The Master Clock frequency changes to the selected frequency once the clock configuration bits are received.
4. If the user does not select a master clock frequency, then the configuration bitstream defaults to the Master Clock frequency of 2.5MHz.

This internal CMOS oscillator is available to the user by routing it as an input clock to the clock tree. For further information about the use of this oscillator for configuration or user mode, please see the list of additional technical documentation at the end of this data sheet.

Table 2-16. Selectable Master Clock (CCLK) Frequencies During Configuration

Non-Encrypted Mode CCLK (MHz)			Encrypted Mode CCLK (MHz)
2.5 ¹	13.0	45.0	2.5 ¹
4.3	15.0	55.0	5.4
5.4	20.0	60.0	10.0
6.9	26.0	—	34.0
8.1	30.0	—	41.0
9.2	34.0	—	45.0
10.0	41.0	130.0	—

1. Software default frequency.

Density Shifting

The LatticeECP2/M family is designed to ensure that different density devices in the same family and in the same package have the same pinout. Furthermore, the architecture ensures a high success rate when performing design migration from lower density devices to higher density devices. In many cases, it is also possible to shift a lower utilization design targeted for a high-density device to a lower density device. However, the exact details of the final resource utilization will impact the likelihood of success in each case. Design migration between LatticeECP2 and LatticeECP2M families is not possible. For specific requirements relating to sysCONFIG pins of the ECP2M50, M70 and M100, see the Logic Signal Connections tables.

Absolute Maximum Ratings^{1, 2, 3}

Supply Voltage V_{CC}	-0.5 to 1.32V
Supply Voltage V_{CCAUX}	-0.5 to 3.75V
Supply Voltage V_{CCJ}	-0.5 to 3.75V
Output Supply Voltage V_{CCIO}	-0.5 to 3.75V
Input or I/O Tristate Voltage Applied ⁴	-0.5 to 3.75V
Storage Temperature (Ambient)	-65 to 150°C
Junction Temperature (T_j)	+125°C

1. Stress above those listed under the “Absolute Maximum Ratings” may cause permanent damage to the device. Functional operation of the device at these or any other conditions above those indicated in the operational sections of this specification is not implied.
2. Compliance with the Lattice *Thermal Management* document is required.
3. All voltages referenced to GND.
4. Overshoot and undershoot of -2V to ($V_{IHMAX} + 2$) volts is permitted for a duration of <20ns.

Recommended Operating Conditions

Symbol	Parameter	Min.	Max.	Units
$V_{CC}^{1,4,5}$	Core Supply Voltage	1.14	1.26	V
$V_{CCAUX}^{1,3,4,5}$	Auxiliary Supply Voltage	3.135	3.465	V
V_{CCPLL}	PLL Supply Voltage	1.14	1.26	V
$V_{CCIO}^{1,2,4}$	I/O Driver Supply Voltage	1.14	3.465	V
V_{CCJ}^1	Supply Voltage for IEEE 1149.1 Test Access Port	1.14	3.465	V
t_{JCOM}	Junction Temperature, Commercial Operation	0	85	°C
t_{JIND}	Junction Temperature, Industrial Operation	-40	100	°C
SERDES External Power Supply (For LatticeECP2M Family Only)				
V_{CCIB}	Input Buffer Power Supply (1.2V)	1.14	1.26	V
	Input Buffer Power Supply (1.5V)	1.425	1.575	V
V_{CCOB}	Output Buffer Power Supply (1.2V)	1.14	1.26	V
	Output Buffer Power Supply (1.5V)	1.425	1.575	V
$V_{CCAUX33}$	Termination Resistor Switching Power Supply	3.135	3.465	V
$V_{CCR\!X}^6$	Receive Power Supply	1.14	1.26	V
$V_{CCT\!X}^6$	Transmit Power Supply	1.14	1.26	V
V_{CCP}^6	PLL and Reference Clock Buffer Power	1.14	1.26	V

1. If V_{CCIO} or V_{CCJ} is set to 1.2V, they must be connected to the same power supply as V_{CC} . If V_{CCIO} or V_{CCJ} is set to 3.3V, they must be connected to the same power supply as V_{CCAUX} . V_{CC} and V_{CCPLL} must be connected to the same power supply.
2. See recommended voltages by I/O standard in subsequent table.
3. V_{CCAUX} ramp rate must not exceed 30mV/μs during power-up when transitioning between 0V and 3.3V.
4. For proper power-up configuration, users must ensure that the configuration control signals such as the CFGx, INITN, PROGRAMN and DONE pins are driven to the proper logic levels when the device powers up. The device power-up is triggered by the last of V_{CC} , V_{CCAUX} or V_{CCIO8} supplies that reaches its minimum valid levels. Alternatively, if the configuration control signals are pulled up by V_{CCIO8} , the V_{CCIO8} (configuration I/O bank) voltage must be powered up prior to or at the same time as the last of V_{CC} or V_{CCAUX} reaches its minimum levels.
5. For power-up, V_{CC} must reach its valid minimum value before powering up V_{CCAUX} (LatticeECP2/M “S” version devices only).
6. $V_{CCR\!X}$, $V_{CCT\!X}$ and V_{CCP} must be tied together in each quad and all quads need to be powered up.

Hot Socketing Specifications^{1, 2, 3, 4}

Symbol	Parameter	Condition	Min.	Typ.	Max.	Units
I_{DK}	Input or I/O leakage current	$0 \leq V_{IN} \leq V_{IH} \text{ (MAX.)}$	—	—	+/-1000	μA
I_{HDIN}^5	SERDES average input current when device is powered down and inputs are driven		—	—	4	mA

- V_{CC} , V_{CCAUX} and V_{CCIO} should rise/fall monotonically. V_{CC} and V_{CCPLL} must be connected to the same power supply (applies to ECP2-6, ECP2-12 and ECP2-20 only).
- $0 \leq V_{CC} \leq V_{CC} \text{ (MAX)}$, $0 \leq V_{CCIO} \leq V_{CCIO} \text{ (MAX)}$ or $0 \leq V_{CCAUX} \leq V_{CCAUX} \text{ (MAX)}$.
- I_{DK} is additive to I_{PU} , I_{PW} or I_{BH} .
- LVC MOS and LV TTL only.
- Assumes that the device is powered down with all supplies grounded, both P and N inputs driven by a CML driver with maximum allowed V_{CCIB} of 1.575V, 8b10b data and internal AC coupling.

DC Electrical Characteristics

Over Recommended Operating Conditions

Symbol	Parameter	Condition	Min.	Typ.	Max.	Units
I_{IL}, I_{IH}^1	Input or I/O Low Leakage	$0 \leq V_{IN} \leq (V_{CCIO} - 0.2V)$	—	—	10	μA
I_{IH}^1	Input or I/O High Leakage	$(V_{CCIO} - 0.2V) < V_{IN} \leq 3.6V$	—	—	150	μA
I_{PU}	I/O Active Pull-up Current	$0 \leq V_{IN} \leq 0.7 V_{CCIO}$	-30	—	-210	μA
I_{PD}	I/O Active Pull-down Current	$V_{IL} (MAX) \leq V_{IN} \leq V_{IH} (MAX)$	30	—	210	μA
I_{BHLS}	Bus Hold Low Sustaining Current	$V_{IN} = V_{IL} (MAX)$	30	—	—	μA
I_{BHHS}	Bus Hold High Sustaining Current	$V_{IN} = 0.7 V_{CCIO}$	-30	—	—	μA
I_{BHLO}	Bus Hold Low Overdrive Current	$0 \leq V_{IN} \leq V_{CCIO}$	—	—	210	μA
I_{BHHO}	Bus Hold High Overdrive Current	$0 \leq V_{IN} \leq V_{CCIO}$	—	—	-210	μA
V_{BHT}	Bus Hold Trip Points	$0 \leq V_{IN} \leq V_{IH} (MAX)$	$V_{IL} (MAX)$	—	$V_{IH} (MIN)$	V
C1	I/O Capacitance ²	$V_{CCIO} = 3.3V, 2.5V, 1.8V, 1.5V, 1.2V,$ $V_{CC} = 1.2V, V_{IO} = 0 \text{ to } V_{IH} (MAX)$	—	8	—	pf
C2	Dedicated Input Capacitance ²	$V_{CCIO} = 3.3V, 2.5V, 1.8V, 1.5V, 1.2V,$ $V_{CC} = 1.2V, V_{IO} = 0 \text{ to } V_{IH} (MAX)$	—	6	—	pf

1. Input or I/O leakage current is measured with the pin configured as an input or as an I/O with the output driver tri-stated. It is not measured with the output driver active. Bus maintenance circuits are disabled.

2. T_A 25°C, $f = 1.0MHz$.

LatticeECP2 Supply Current (Standby)^{1, 2, 3, 4}**Over Recommended Operating Conditions**

Symbol	Parameter	Device	Typ. ⁵	Units
I _{CC}	Core Power Supply Current	ECP2-6	10	mA
		ECP2-12	20	mA
		ECP2-20	30	mA
		ECP2-35	50	mA
		ECP2-50	70	mA
		ECP2-70	100	mA
I _{CCAUX}	Auxiliary Power Supply Current	ECP2-6	24	mA
		ECP2-12	24	mA
		ECP2-20	24	mA
		ECP2-35	24	mA
		ECP2-50	24	mA
		ECP2-70	24	mA
I _{CCGPLL}	GPLL Power Supply Current (per GPLL)	ECP2-35, -50, -70 Only	0.5	mA
I _{CCSPLL}	GPLL Power Supply Current (per SPLL)	ECP2-35, -50, -70 Only	0.5	mA
I _{CCIO}	Bank Power Supply Current (Per Bank)	ECP2-6	2	mA
		ECP2-12	2	mA
		ECP2-20	2	mA
		ECP2-35	2	mA
		ECP2-50	2	mA
		ECP2-70	2	mA
I _{CCJ}	VCCJ Power Supply Current	All Devices	3	mA

1. For further information about supply current, please see the list of additional technical documentation at the end of this data sheet.
2. Assumes all outputs are tristated, all inputs are configured as LVCMOS and held at the V_{CCIO} or GND.
3. Frequency 0MHz.
4. Pattern represents a "blank" configuration data file.
5. T_J = 25°C, power supplies at normal voltage.

LatticeECP2M Supply Current (Standby)^{1, 2, 3, 4}

Over Recommended Operating Conditions

Symbol	Parameter	Device	Typ. ⁵	Units
I _{CC}	Core Power Supply Current	ECP2M20	25	mA
		ECP2M35	50	mA
		ECP2M50	85	mA
		ECP2M70	100	mA
		ECP2M100	100	mA
I _{CCAUX}	Auxiliary Power Supply Current	ECP2M20	24	mA
		ECP2M35	24	mA
		ECP2M50	24	mA
		ECP2M70	24	mA
		ECP2M100	24	mA
I _{CCGPLL}	GPLL Power Supply Current (per GPLL)	All Devices	0.5	mA
I _{CCSPLL}	GPLL Power Supply Current (per SPLL)	All Devices	0.5	mA
I _{CCIO}	Bank Power Supply Current (Per Bank)	ECP2M20	2	mA
		ECP2M35	2	mA
		ECP2M50	2	mA
		ECP2M70	2	mA
		ECP2M100	2	mA
I _{CCJ}	V _{CCJ} Power Supply Current	All Devices	3	mA

1. For further information about supply current, please see the list of additional technical documentation at the end of this data sheet.
2. Assumes all outputs are tristated, all inputs are configured as LVCMOS and held at the V_{CCIO} or GND.
3. Frequency 0MHz.
4. Pattern represents a “blank” configuration data file.
5. T_J = 25°C, power supplies at normal voltage.

LatticeECP2 Initialization Supply Current^{1, 2, 3, 4}**Over Recommended Operating Conditions**

Symbol	Parameter	Device	Typ. ^{5, 6}	Units
I_{CC}	Core Power Supply Current	ECP2-6	34	mA
		ECP2-12	54	mA
		ECP2-20	82	mA
		ECP2-35	135	mA
		ECP2-50	187	mA
		ECP2-70	267	mA
I_{CCAUX}	Auxiliary Power Supply Current	ECP2-6	30	mA
		ECP2-12	30	mA
		ECP2-20	30	mA
		ECP2-35	30	mA
		ECP2-50	30	mA
		ECP2-70	30	mA
I_{CCGPLL}	GPLL Power Supply Current (per GPLL)	ECP2-35, -50, -70 Only	0.5	mA
I_{CCSPLL}	SPLL Power Supply Current (per SPLL)	ECP2-35, -50, -70 Only	0.5	mA
I_{CCIO}	Bank Power Supply Current (per Bank)	All Devices	3	mA
I_{CCJ}	VCCJ Power Supply Current	All Devices	4	mA

1. Until DONE signal is active.

2. For further information about supply current, please see the list of additional technical documentation at the end of this data sheet.

3. Assumes all outputs are tristated, all inputs are configured as LVCMOS and held at the V_{CCIO} or GND.

4. Frequency 0MHz.

5. $T_J = 25^\circ\text{C}$, power supplies at nominal voltage.

6. A specific configuration pattern is used that scales with the size of the device; consists of 75% PFU utilization, 50% EBR, and 25% I/O configuration.

LatticeECP2M Initialization Supply Current^{1, 2, 3, 4}**Over Recommended Operating Conditions**

Symbol	Parameter	Device	Typ. ^{5, 6}	Units
I_{CC}	Core Power Supply Current	ECP2M20	41	mA
		ECP2M35	107	mA
		ECP2M50	169	mA
		ECP2M70	254	mA
		ECP2M100	378	mA
I_{CCAUX}	Auxiliary Power Supply Current	ECP2M20	30	mA
		ECP2M35	30	mA
		ECP2M50	30	mA
		ECP2M70	30	mA
		ECP2M100	30	mA
I_{CCGPLL}	GPLL Power Supply Current (per GPLL)	All Devices	0.5	mA
I_{CCSPLL}	SPLL Power Supply Current (per SPLL)	All Devices	0.5	mA
I_{CCIO}	Bank Power Supply Current (per Bank)	All Devices	3	mA
I_{CCJ}	VCCJ Power Supply Current	All Devices	4	mA

1. Until DONE signal is active.

2. For further information about supply current, please see the list of additional technical documentation at the end of this data sheet.

3. Assumes all outputs are tristated, all inputs are configured as LVCMOS and held at the V_{CCIO} or GND.

4. Frequency 0MHz.

5. $T_J = 25^\circ\text{C}$, power supplies at nominal voltage.

6. A specific configuration pattern is used that scales with the size of the device; consists of 75% PFU utilization, 50% EBR, and 25% I/O configuration.

SERDES Power Supply Requirements (LatticeECP2M Family Only)¹

Over Recommended Operating Conditions

Symbol	Description	Typ. ²	Units
Standby (Power Down)			
I _{CCTX-SB}	V _{CCTX} current (per channel)	10	μA
I _{CCR_X-SB}	V _{CCR_X} current (per channel)	75	μA
I _{CCIB-SB}	Input buffer current (per channel)	0	μA
I _{CCOB-SB}	Output buffer current (per channel)	0	μA
I _{CCP-SB}	SERDES PLL current (per quad)	30	μA
I _{CCAX33-SB}	SERDES termination current (per quad)	10	μA
Operating (Data Rate = 3.125 Gbps)			
I _{CCTX-OP}	V _{CCTX} current (per channel)	19	mA
I _{CCR_X-OP}	V _{CCR_X} current (per channel)	34	mA
I _{CCIB-OP}	Input buffer current (per channel)	4	mA
I _{CCOB-OP}	Output buffer current (per channel)	13	mA
I _{CCP-OP}	SERDES PLL current (per quad)	26	mA
I _{CCAX33-OP}	SERDES termination current (per quad)	0.01	mA

1. Equalization enabled, pre-emphasis disabled.
2. T_J = 25°C, power supplies at nominal voltage.

SERDES Power (LatticeECP2M Family Only)

Table 3-1 presents the SERDES power for one channel.

Table 3-1. SERDES Power¹

Symbol	Description	Typ. ²	Units
P _{S-1CH-31}	SERDES power (one channel @ 3.125 Gbps)	90	mW
P _{S-1CH-25}	SERDES power (one channel @ 2.5 Gbps)	87	mW
P _{S-1CH-12}	SERDES power (one channel @ 1.25 Gbps)	86	mW
P _{S-1CH-02}	SERDES power (one channel @ 250 Mbps)	76	mW

1. One quarter of the total quad power (includes contribution from common circuits, all channels in the quad operating, pre-emphasis disabled, equalization enabled).
2. Typical values measured at 25°C and 1.2V.

sysI/O Recommended Operating Conditions

Standard	V _{CCIO}			V _{REF} (V)		
	Min.	Typ.	Max.	Min.	Typ.	Max.
LVCMOS 3.3 ²	3.135	3.3	3.465	—	—	—
LVCMOS 2.5 ²	2.375	2.5	2.625	—	—	—
LVCMOS 1.8	1.71	1.8	1.89	—	—	—
LVCMOS 1.5	1.425	1.5	1.575	—	—	—
LVCMOS 1.2 ²	1.14	1.2	1.26	—	—	—
LVTTL ²	3.135	3.3	3.465	—	—	—
PCI	3.135	3.3	3.465	—	—	—
SSTL18 ² Class I, II	1.71	1.8	1.89	0.833	0.9	0.969
SSTL2 ² Class I, II	2.375	2.5	2.625	1.15	1.25	1.35
SSTL3 ² Class I, II	3.135	3.3	3.465	1.3	1.5	1.7
HSTL ² 15 Class I	1.425	1.5	1.575	0.68	0.75	0.9
HSTL ² 18 Class I, II	1.71	1.8	1.89	0.816	0.9	1.08
LVDS ²	2.375	2.5	2.625	—	—	—
MLVDS25 ¹	2.375	2.5	2.625	—	—	—
LVPECL33 ^{1,2}	3.135	3.3	3.465	—	—	—
BLVDS25 ^{1,2}	2.375	2.5	2.625	—	—	—
RSDS ^{1,2}	2.375	2.5	2.625	—	—	—
SSTL18D_I ² , II ²	1.71	1.8	1.89	—	—	—
SSTL25D_I ² , II ²	2.375	2.5	2.625	—	—	—
SSTL33D_I ² , II ²	3.135	3.3	3.465	—	—	—
HSTL15D_I ²	1.425	1.5	1.575	—	—	—
HSTL18D_I ² , II ²	1.71	1.8	1.89	—	—	—

1. Inputs on chip. Outputs are implemented with the addition of external resistors.

2. Input on this standard does not depend on the value of V_{CCIO}.

sysI/O Single-Ended DC Electrical Characteristics

Input/Output Standard	V_{IL}		V_{IH}		V_{OL} Max. (V)	V_{OH} Min. (V)	I_{OL}^1 (mA)	I_{OH}^1 (mA)
	Min. (V)	Max. (V)	Min. (V)	Max. (V)				
LVCMOS 3.3	-0.3	0.8	2.0	3.6	0.4	$V_{CCIO} - 0.4$	20, 16, 12, 8, 4	-20, -16, -12, -8, -4
					0.2	$V_{CCIO} - 0.2$	0.1	-0.1
LVTTTL	-0.3	0.8	2.0	3.6	0.4	$V_{CCIO} - 0.4$	20, 16, 12, 8, 4	-20, -16, -12, -8, -4
					0.2	$V_{CCIO} - 0.2$	0.1	-0.1
LVCMOS 2.5	-0.3	0.7	1.7	3.6	0.4	$V_{CCIO} - 0.4$	20, 16, 12, 8, 4	-20, -16, -12, -8, -4
					0.2	$V_{CCIO} - 0.2$	0.1	-0.1
LVCMOS 1.8	-0.3	$0.35 V_{CCIO}$	$0.65 V_{CCIO}$	3.6	0.4	$V_{CCIO} - 0.4$	16, 12, 8, 4	-16, -12, -8, -4
					0.2	$V_{CCIO} - 0.2$	0.1	-0.1
LVCMOS 1.5	-0.3	$0.35 V_{CCIO}$	$0.65 V_{CCIO}$	3.6	0.4	$V_{CCIO} - 0.4$	8, 4	-8, -4
					0.2	$V_{CCIO} - 0.2$	0.1	-0.1
LVCMOS 1.2	-0.3	$0.35 V_{CC}$	$0.65 V_{CC}$	3.6	0.4	$V_{CCIO} - 0.4$	6, 2	-6, -2
					0.2	$V_{CCIO} - 0.2$	0.1	-0.1
PCI	-0.3	$0.3 V_{CCIO}$	$0.5 V_{CCIO}$	3.6	$0.1 V_{CCIO}$	$0.9 V_{CCIO}$	1.5	-0.5
SSTL3 Class I	-0.3	$V_{REF} - 0.2$	$V_{REF} + 0.2$	3.6	0.7	$V_{CCIO} - 1.1$	8	-8
SSTL3 Class II	-0.3	$V_{REF} - 0.2$	$V_{REF} + 0.2$	3.6	0.5	$V_{CCIO} - 0.9$	16	-16
SSTL2 Class I	-0.3	$V_{REF} - 0.18$	$V_{REF} + 0.18$	3.6	0.54	$V_{CCIO} - 0.62$	7.6	-7.6
							12	-12
SSTL2 Class II	-0.3	$V_{REF} - 0.18$	$V_{REF} + 0.18$	3.6	0.35	$V_{CCIO} - 0.43$	15.2	-15.2
							20	-20
SSTL18 Class I	-0.3	$V_{REF} - 0.125$	$V_{REF} + 0.125$	3.6	0.4	$V_{CCIO} - 0.4$	6.7	-6.7
SSTL18 Class II	-0.3	$V_{REF} - 0.125$	$V_{REF} + 0.125$	3.6	0.28	$V_{CCIO} - 0.28$	8	-8
							11	-11
HSTL Class I	-0.3	$V_{REF} - 0.1$	$V_{REF} + 0.1$	3.6	0.4	$V_{CCIO} - 0.4$	4	-4
							8	-8
HSTL18 Class I	-0.3	$V_{REF} - 0.1$	$V_{REF} + 0.1$	3.6	0.4	$V_{CCIO} - 0.4$	8	-8
							12	-12
HSTL18 Class II	-0.3	$V_{REF} - 0.1$	$V_{REF} + 0.1$	3.6	0.4	$V_{CCIO} - 0.4$	16	-16

1. The average DC current drawn by I/Os between GND connections, or between the last GND in an I/O bank and the end of an I/O bank, as shown in the logic signal connections table shall not exceed $n * 8\text{mA}$, where n is the number of I/Os between bank GND connections or between the last GND in a bank and the end of a bank.

sys/O Differential Electrical Characteristics**LVDS****Over Recommended Operating Conditions**

Parameter	Description	Test Conditions	Min.	Typ.	Max.	Units
V_{INP} V_{INM}	Input Voltage		0	—	2.4	V
V_{CM}	Input Common Mode Voltage	Half the Sum of the Two Inputs	0.05	—	2.35	V
V_{THD}	Differential Input Threshold	Difference Between the Two Inputs	+/-100	—	—	mV
I_{IN}	Input Current	Power On or Power Off	—	—	+/-10	μ A
V_{OH}	Output High Voltage for V_{OP} or V_{OM}	$R_T = 100$ Ohm	—	1.38	1.60	V
V_{OL}	Output Low Voltage for V_{OP} or V_{OM}	$R_T = 100$ Ohm	0.9V	1.03	—	V
V_{OD}	Output Voltage Differential	$(V_{OP} - V_{OM})$, $R_T = 100$ Ohm	250	350	450	mV
ΔV_{OD}	Change in V_{OD} Between High and Low		—	—	50	mV
V_{OS}	Output Voltage Offset	$(V_{OP} + V_{OM})/2$, $R_T = 100$ Ohm	1.125	1.20	1.375	V
ΔV_{OS}	Change in V_{OS} Between H and L		—	—	50	mV
I_{SA}	Output Short Circuit Current	$V_{OD} = 0V$ Driver Outputs Shorted to Ground	—	—	24	mA
I_{SAB}	Output Short Circuit Current	$V_{OD} = 0V$ Driver Outputs Shorted to Each Other	—	—	12	mA

Differential HSTL and SSTL

Differential HSTL and SSTL outputs are implemented as a pair of complementary single-ended outputs. All allowable single-ended output classes (class I and class II) are supported in this mode.

For further information about LVPECL, RSDS, MLVDS, BLVDS and other differential interfaces please see the list of additional technical information at the end of this data sheet.

LVDS25E

The top and bottom sides of LatticeECP2/M devices support LVDS outputs via emulated complementary LVCMOS outputs in conjunction with a parallel resistor across the driver outputs. The scheme shown in Figure 3-1 is one possible solution for point-to-point signals.

Figure 3-1. LVDS25E Output Termination Example

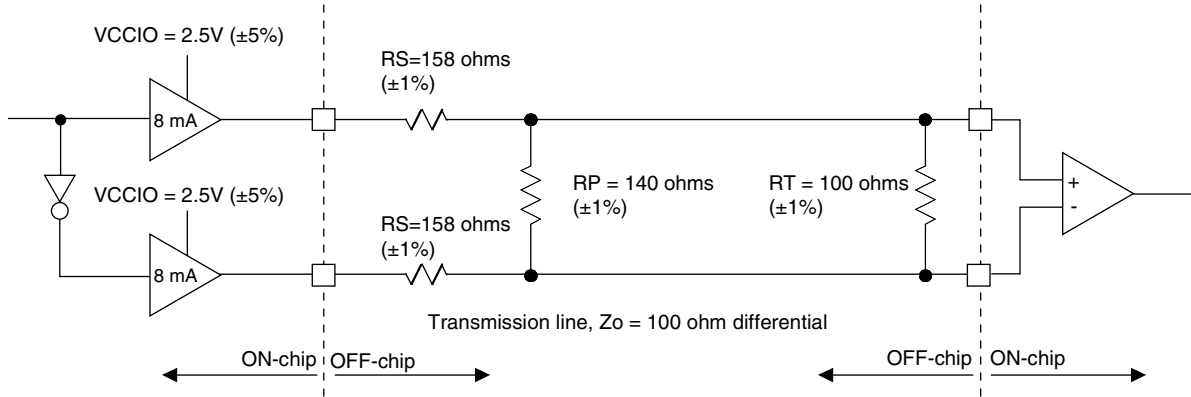

Table 3-2. LVDS25E DC Conditions

Parameter	Description	Typical	Units
V _{CCIO}	Output Driver Supply (+/-5%)	2.50	V
Z _{OUT}	Driver Impedance	20	Ω
R _S	Driver Series Resistor (+/-1%)	158	Ω
R _P	Driver Parallel Resistor (+/-1%)	140	Ω
R _T	Receiver Termination (+/-1%)	100	Ω
V _{OH}	Output High Voltage	1.43	V
V _{OL}	Output Low Voltage	1.07	V
V _{OD}	Output Differential Voltage	0.35	V
V _{CM}	Output Common Mode Voltage	1.25	V
Z _{BACK}	Back Impedance	100.5	Ω
I _{DC}	DC Output Current	6.03	mA

LVCMOS33D

All I/O banks support emulated differential I/O using the LVCMOS33D I/O type. This option, along with the external resistor network, provides the system designer the flexibility to place differential outputs on an I/O bank with 3.3V VCCIO. The default drive current for LVCMOS33D output is 12mA with the option to change the device strength to 4mA, 8mA, 16mA or 20mA. Follow the LVCMOS33 specifications for the DC characteristics of the LVCMOS33D.

BLVDS

The LatticeECP2/M devices support the BLVDS standard. This standard is emulated using complementary LVC-MOS outputs in conjunction with a parallel external resistor across the driver outputs. BLVDS is intended for use when multi-drop and bi-directional multi-point differential signaling is required. The scheme shown in Figure 3-2 is one possible solution for bi-directional multi-point differential signals.

Figure 3-2. BLVDS Multi-point Output Example

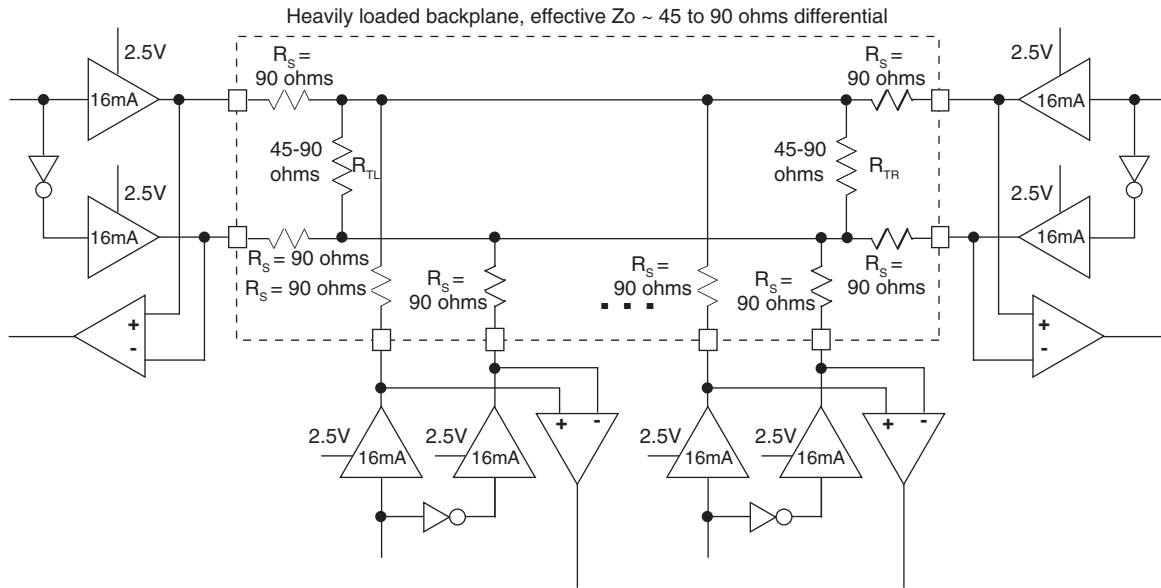

Table 3-3. BLVDS DC Conditions¹

Over Recommended Operating Conditions

Parameter	Description	Typical		Units
		Zo = 45Ω	Zo = 90Ω	
V _{CCIO}	Output Driver Supply (+/- 5%)	2.50	2.50	V
Z _{OUT}	Driver Impedance	10.00	10.00	Ω
R _S	Driver Series Resistor (+/- 1%)	90.00	90.00	Ω
R _{TL}	Driver Parallel Resistor (+/- 1%)	45.00	90.00	Ω
R _{TR}	Receiver Termination (+/- 1%)	45.00	90.00	Ω
V _{OH}	Output High Voltage	1.38	1.48	V
V _{OL}	Output Low Voltage	1.12	1.02	V
V _{OD}	Output Differential Voltage	0.25	0.46	V
V _{CM}	Output Common Mode Voltage	1.25	1.25	V
I _{DC}	DC Output Current	11.24	10.20	mA

1. For input buffer, see LVDS table.

LVPECL

The LatticeECP2/M devices support the differential LVPECL standard. This standard is emulated using complementary LVCMOS outputs in conjunction with a parallel resistor across the driver outputs. The LVPECL input standard is supported by the LVDS differential input buffer. The scheme shown in Figure 3-3 is one possible solution for point-to-point signals.

Figure 3-3. Differential LVPECL

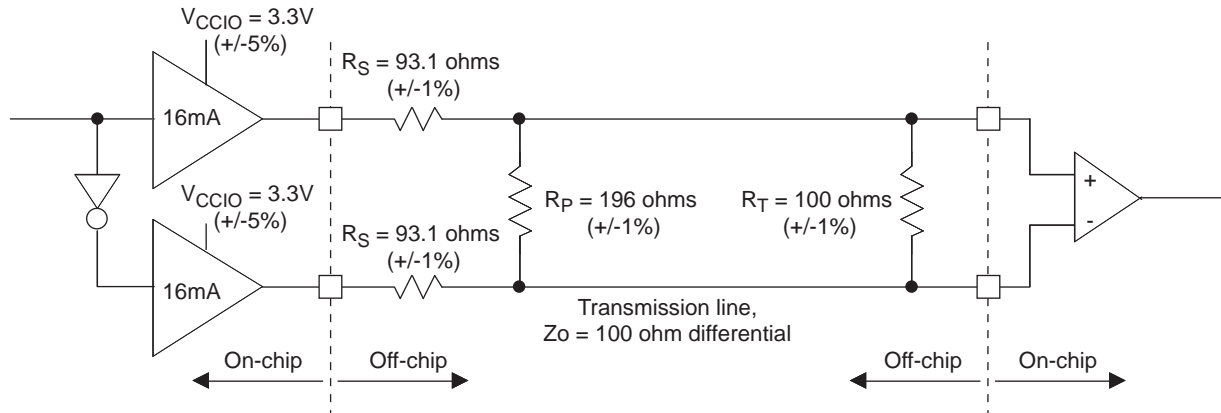

Table 3-4. LVPECL DC Conditions¹

Over Recommended Operating Conditions

Parameter	Description	Typical	Units
V_{CCIO}	Output Driver Supply (+/-5%)	3.30	V
Z_{OUT}	Driver Impedance	10	Ω
R_S	Driver Series Resistor (+/-1%)	93	Ω
R_P	Driver Parallel Resistor (+/-1%)	196	Ω
R_T	Receiver Termination (+/-1%)	100	Ω
V_{OH}	Output High Voltage	2.05	V
V_{OL}	Output Low Voltage	1.25	V
V_{OD}	Output Differential Voltage	0.80	V
V_{CM}	Output Common Mode Voltage	1.65	V
Z_{BACK}	Back Impedance	100.5	Ω
I_{DC}	DC Output Current	12.11	mA

1. For input buffer, see LVDS table.

RSDS

The LatticeECP2/M devices support differential RSDS standard. This standard is emulated using complementary LVCMOS outputs in conjunction with a parallel resistor across the driver outputs. The RSDS input standard is supported by the LVDS differential input buffer. The scheme shown in Figure 3-4 is one possible solution for RSDS standard implementation. Resistor values in Figure 3-4 are industry standard values for 1% resistors.

Figure 3-4. RSDS (Reduced Swing Differential Signaling)

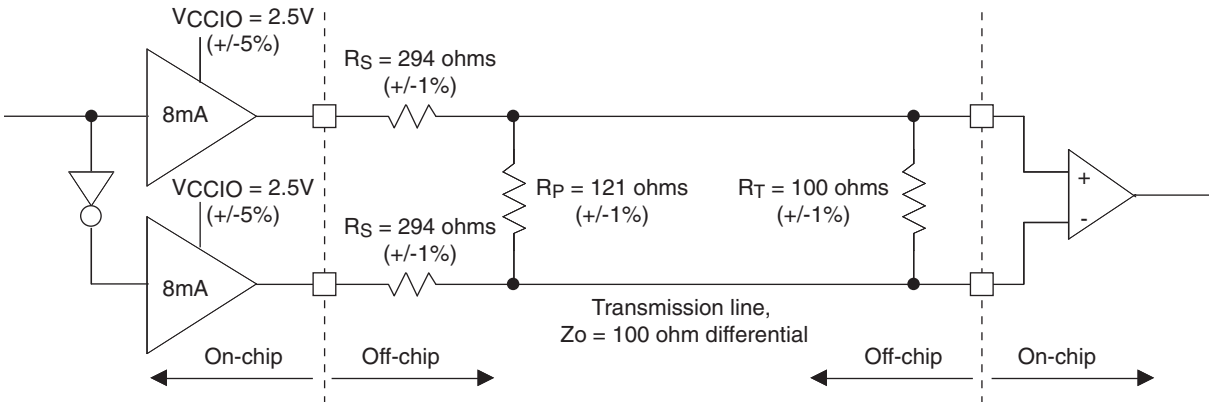

Table 3-5. RSDS DC Conditions¹

Over Recommended Operating Conditions

Parameter	Description	Typical	Units
V_{CCIO}	Output Driver Supply (+/-5%)	2.50	V
Z_{OUT}	Driver Impedance	20	Ω
R_S	Driver Series Resistor (+/-1%)	294	Ω
R_P	Driver Parallel Resistor (+/-1%)	121	Ω
R_T	Receiver Termination (+/-1%)	100	Ω
V_{OH}	Output High Voltage	1.35	V
V_{OL}	Output Low Voltage	1.15	V
V_{OD}	Output Differential Voltage	0.20	V
V_{CM}	Output Common Mode Voltage	1.25	V
Z_{BACK}	Back Impedance	101.5	Ω
I_{DC}	DC Output Current	3.66	mA

1. For input buffer, see LVDS table.

MLVDS

The LatticeECP2/M devices support the differential MLVDS standard. This standard is emulated using complementary LVCMOS outputs in conjunction with a parallel resistor across the driver outputs. The MLVDS input standard is supported by the LVDS differential input buffer. The scheme shown in Figure 3-5 is one possible solution for MLVDS standard implementation. Resistor values in Figure 3-5 are industry standard values for 1% resistors.

Figure 3-5. MLVDS (Multipoint Low Voltage Differential Signaling)

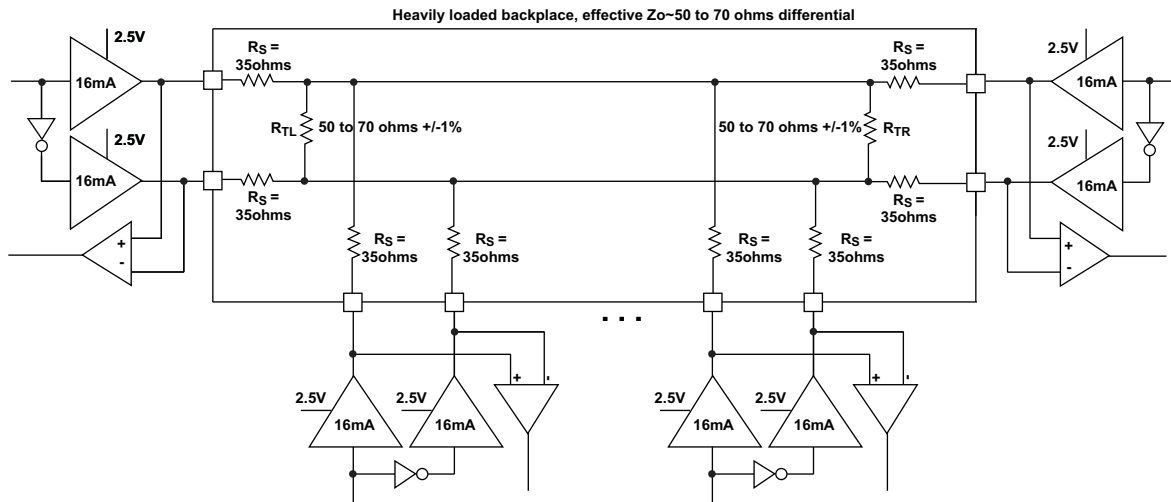

Table 3-6. MLVDS DC Conditions¹

Parameter	Description	Typical		Units
		$Z_o=50\Omega$	$Z_o=70\Omega$	
V_{CCIO}	Output Driver Supply (+/-5%)	2.50	2.50	V
Z_{OUT}	Driver Impedance	10.00	10.00	Ω
R_S	Driver Series Resistor (+/-1%)	35.00	35.00	Ω
R_{TL}	Driver Parallel Resistor (+/-1%)	50.00	70.00	Ω
R_{TR}	Receiver Termination (+/-1%)	50.00	70.00	Ω
V_{OH}	Output High Voltage	1.52	1.60	V
V_{OL}	Output Low Voltage	0.98	0.90	V
V_{OD}	Output Differential Voltage	0.54	0.70	V
V_{CM}	Output Common Mode Voltage	1.25	1.25	V
I_{DC}	DC Output Current	21.74	20.00	mA

1. For input buffer, see LVDS table.

For further information about LVPECL, RSDS, MLVDS, BLVDS and other differential interfaces please see the list of additional technical information at the end of this data sheet.

Typical Building Block Function Performance¹**Pin-to-Pin Performance (LVCMOS25 12mA Drive)**

Function	-7 Timing	Units
Basic Functions		
16-bit Decoder	3.8	ns
32-bit Decoder	4.5	ns
64-bit Decoder	5.0	ns
4:1 MUX	3.2	ns
8:1 MUX	3.4	ns
16:1 MUX	3.5	ns
32:1 MUX	4.0	ns

1. These timing numbers were generated using the ispLEVER design tool. Exact performance may vary with device and tool version. The tool uses internal parameters that have been characterized but are not tested on every device.

Timing v.A 0.11

Register-to-Register Performance

Function	-7 Timing	Units
Basic Functions		
16-bit Decoder	599	MHz
32-bit Decoder	542	MHz
64-bit Decoder	417	MHz
4:1 MUX	847	MHz
8:1 MUX	803	MHz
16:1 MUX	660	MHz
32:1 MUX	577	MHz
8-bit Adder	591	MHz
16-bit Adder	500	MHz
64-bit Adder	306	MHz
16-bit Counter	488	MHz
32-bit Counter	378	MHz
64-bit Counter	260	MHz
64-bit Accumulator	253	MHz
Embedded Memory Functions		
512x36 Single Port RAM, EBR Output Registers	370	MHz
1024x18 True-Dual Port RAM (Write Through or Normal, EBR Output Registers)	370	MHz
1024x18 True-Dual Port RAM (Write Through or Normal, PLC Output Registers)	280	MHz
Distributed Memory Functions		
16x4 Pseudo-Dual Port RAM (One PFU)	819	MHz
32x4 Pseudo-Dual Port RAM	521	MHz
64x8 Pseudo-Dual Port RAM	435	MHz
DSP Functions		
18x18 Multiplier (All Registers)	420	MHz

Register-to-Register Performance (Continued)

Function	-7 Timing	Units
9x9 Multiplier (All Registers)	420	MHz
36x36 Multiplier (All Registers)	372	MHz
18x18 Multiplier/Accumulate (Input and Output Registers)	295	MHz
18x18 Multiplier-Add/Sub-Sum (All Registers)	420	MHz
DSP IP Functions		
16-Tap Fully-Parallel FIR Filter	304	MHz
1024-pt, Radix 4, Decimation in Frequency FFT	227	MHz
8x8 Matrix Multiplier	223	MHz

Timing v.A 0.11

Derating Timing Tables

Logic timing provided in the following sections of this data sheet and the ispLEVER design tools are worst case numbers in the operating range. Actual delays at nominal temperature and voltage for best case process, can be much better than the values given in the tables. The ispLEVER design tool can provide logic timing numbers at a particular temperature and voltage.

LatticeECP2/M External Switching Characteristics⁹

Over Recommended Operating Conditions

Parameter	Description	Device	-7		-6		-5		Units
			Min.	Max.	Min.	Max.	Min.	Max.	
General I/O Pin Parameters (using Primary Clock without PLL)¹									
t _{CO}	Clock to Output - PIO Output Register	LFE2-6	—	3.50	—	3.90	—	4.20	ns
		LFE2-12	—	3.50	—	3.90	—	4.20	ns
		LFE2-20	—	3.50	—	3.90	—	4.20	ns
		LFE2-35	—	3.50	—	3.90	—	4.20	ns
		LFE2-50	—	3.50	—	3.90	—	4.20	ns
		LFE2-70	—	3.70	—	4.10	—	4.40	ns
		LFE2M20	—	3.90	—	4.30	—	4.70	ns
		LFE2M35	—	3.90	—	4.30	—	4.70	ns
		LFE2M50	—	4.50	—	5.00	—	5.40	ns
		LFE2M70	—	4.50	—	5.00	—	5.40	ns
		LFE2M100	—	4.50	—	5.00	—	5.40	ns
t _{SU}	Clock to Data Setup - PIO Input Register	LFE2-6	0.00	—	0.00	—	0.00	—	ns
		LFE2-12	0.00	—	0.00	—	0.00	—	ns
		LFE2-20	0.00	—	0.00	—	0.00	—	ns
		LFE2-35	0.00	—	0.00	—	0.00	—	ns
		LFE2-50	0.00	—	0.00	—	0.00	—	ns
		LFE2-70	0.00	—	0.00	—	0.00	—	ns
		LFE2M20	0.00	—	0.00	—	0.00	—	ns
		LFE2M35	0.00	—	0.00	—	0.00	—	ns
		LFE2M50	0.00	—	0.00	—	0.00	—	ns
		LFE2M70	0.00	—	0.00	—	0.00	—	ns
		LFE2M100	0.00	—	0.00	—	0.00	—	ns
t _H	Clock to Data Hold - PIO Input Register	LFE2-6	1.40	—	1.70	—	1.90	—	ns
		LFE2-12	1.40	—	1.70	—	1.90	—	ns
		LFE2-20	1.40	—	1.70	—	1.90	—	ns
		LFE2-35	1.40	—	1.70	—	1.90	—	ns
		LFE2-50	1.40	—	1.70	—	1.90	—	ns
		LFE2-70	1.40	—	1.70	—	1.90	—	ns
		LFE2M20	1.40	—	1.70	—	1.90	—	ns
		LFE2M35	1.40	—	1.70	—	1.90	—	ns
		LFE2M50	1.80	—	2.10	—	2.30	—	ns
		LFE2M70	1.80	—	2.10	—	2.30	—	ns
		LFE2M100	1.80	—	2.10	—	2.30	—	ns

LatticeECP2/M External Switching Characteristics⁹ (Continued)

Over Recommended Operating Conditions

Parameter	Description	Device	-7		-6		-5		Units
			Min.	Max.	Min.	Max.	Min.	Max.	
t _{SU_DEL}	Clock to Data Setup - PIO Input Register with Data Input Delay	LFE2-6	1.40	—	1.70	—	1.90	—	ns
		LFE2-12	1.40	—	1.70	—	1.90	—	ns
		LFE2-20	1.40	—	1.70	—	1.90	—	ns
		LFE2-35	1.40	—	1.70	—	1.90	—	ns
		LFE2-50	1.40	—	1.70	—	1.90	—	ns
		LFE2-70	1.40	—	1.70	—	1.90	—	ns
		LFE2M20	1.40	—	1.70	—	1.90	—	ns
		LFE2M35	1.40	—	1.70	—	1.90	—	ns
		LFE2M50	1.40	—	1.70	—	1.90	—	ns
		LFE2M70	1.40	—	1.70	—	1.90	—	ns
LFE2M100	1.40	—	1.70	—	1.90	—	ns		
t _{H_DEL}	Clock to Data Hold - PIO Input Register with Input Data Delay	LFE2-6	0.00	—	0.00	—	0.00	—	ns
		LFE2-12	0.00	—	0.00	—	0.00	—	ns
		LFE2-20	0.00	—	0.00	—	0.00	—	ns
		LFE2-35	0.00	—	0.00	—	0.00	—	ns
		LFE2-50	0.00	—	0.00	—	0.00	—	ns
		LFE2-70	0.00	—	0.00	—	0.00	—	ns
		LFE2M20	0.00	—	0.00	—	0.00	—	ns
		LFE2M35	0.00	—	0.00	—	0.00	—	ns
		LFE2M50	0.00	—	0.00	—	0.00	—	ns
		LFE2M70	0.00	—	0.00	—	0.00	—	ns
LFE2M100	0.00	—	0.00	—	0.00	—	ns		
f _{MAX_IO}	Clock Frequency of I/O Register and PFU Register	ECP2/M	—	420	—	357	—	311	MHz
General I/O Pin Parameters (using Edge Clock without PLL)¹									
t _{COE}	Clock to Output - PIO Output Register	LFE2-6	—	2.60	—	2.90	—	3.20	ns
		LFE2-12	—	2.60	—	2.90	—	3.20	ns
		LFE2-20	—	2.60	—	2.90	—	3.20	ns
		LFE2-35	—	2.60	—	2.90	—	3.20	ns
		LFE2-50	—	2.60	—	2.90	—	3.20	ns
		LFE2-70	—	2.60	—	2.90	—	3.20	ns
		LFE2M20	—	2.60	—	2.90	—	3.20	ns
		LFE2M35	—	2.60	—	2.90	—	3.20	ns
		LFE2M50	—	3.10	—	3.40	—	3.70	ns
		LFE2M70	—	3.10	—	3.40	—	3.70	ns
LFE2M100	—	3.10	—	3.40	—	3.70	ns		

LatticeECP2/M External Switching Characteristics⁹ (Continued)

Over Recommended Operating Conditions

Parameter	Description	Device	-7		-6		-5		Units
			Min.	Max.	Min.	Max.	Min.	Max.	
t _{SUE}	Clock to Data Setup - PIO Input Register	LFE2-6	0.00	—	0.00	—	0.00	—	ns
		LFE2-12	0.00	—	0.00	—	0.00	—	ns
		LFE2-20	0.00	—	0.00	—	0.00	—	ns
		LFE2-35	0.00	—	0.00	—	0.00	—	ns
		LFE2-50	0.00	—	0.00	—	0.00	—	ns
		LFE2-70	0.00	—	0.00	—	0.00	—	ns
		LFE2M20	0.00	—	0.00	—	0.00	—	ns
		LFE2M35	0.00	—	0.00	—	0.00	—	ns
		LFE2M50	0.00	—	0.00	—	0.00	—	ns
		LFE2M70	0.00	—	0.00	—	0.00	—	ns
LFE2M100	0.00	—	0.00	—	0.00	—	ns		
t _{HE}	Clock to Data Hold - PIO Input Register	LFE2-6	0.90	—	1.10	—	1.30	—	ns
		LFE2-12	0.90	—	1.10	—	1.30	—	ns
		LFE2-20	0.90	—	1.10	—	1.30	—	ns
		LFE2-35	0.90	—	1.10	—	1.30	—	ns
		LFE2-50	0.90	—	1.10	—	1.30	—	ns
		LFE2-70	0.90	—	1.10	—	1.30	—	ns
		LFE2M20	0.90	—	1.10	—	1.30	—	ns
		LFE2M35	0.90	—	1.10	—	1.30	—	ns
		LFE2M50	1.20	—	1.40	—	1.60	—	ns
		LFE2M70	1.20	—	1.40	—	1.60	—	ns
LFE2M100	1.20	—	1.40	—	1.60	—	ns		
t _{SU_DELE}	Clock to Data Setup - PIO Input Register with Data Input Delay	LFE2-6	1.00	—	1.30	—	1.60	—	ns
		LFE2-12	1.00	—	1.30	—	1.60	—	ns
		LFE2-20	1.00	—	1.30	—	1.60	—	ns
		LFE2-35	1.00	—	1.30	—	1.60	—	ns
		LFE2-50	1.00	—	1.30	—	1.60	—	ns
		LFE2-70	1.00	—	1.30	—	1.60	—	ns
		LFE2M20	1.20	—	1.60	—	1.90	—	ns
		LFE2M35	1.20	—	1.60	—	1.90	—	ns
		LFE2M50	1.20	—	1.60	—	1.90	—	ns
		LFE2M70	1.20	—	1.60	—	1.90	—	ns
LFE2M100	1.20	—	1.60	—	1.90	—	ns		

LatticeECP2/M External Switching Characteristics⁹ (Continued)

Over Recommended Operating Conditions

Parameter	Description	Device	-7		-6		-5		Units
			Min.	Max.	Min.	Max.	Min.	Max.	
t _{H_DELE}	Clock to Data Hold - PIO Input Register with Input Data Delay	LFE2-6	0.00	—	0.00	—	0.00	—	ns
		LFE2-12	0.00	—	0.00	—	0.00	—	ns
		LFE2-20	0.00	—	0.00	—	0.00	—	ns
		LFE2-35	0.00	—	0.00	—	0.00	—	ns
		LFE2-50	0.00	—	0.00	—	0.00	—	ns
		LFE2-70	0.00	—	0.00	—	0.00	—	ns
		LFE2M20	0.00	—	0.00	—	0.00	—	ns
		LFE2M35	0.00	—	0.00	—	0.00	—	ns
		LFE2M50	0.00	—	0.00	—	0.00	—	ns
		LFE2M70	0.00	—	0.00	—	0.00	—	ns
		LFE2M100	0.00	—	0.00	—	0.00	—	ns
f _{MAX_IOE}	Clock Frequency of I/O and PFU Register	ECP2/M	—	420	—	357	—	311	MHz
General I/O Pin Parameters (using Primary Clock with PLL)¹									
t _{COPLL} ¹⁰	Clock to Output - PIO Output Register	LFE2-6	—	2.30	—	2.60	—	2.80	ns
		LFE2-12	—	2.30	—	2.60	—	2.80	ns
		LFE2-20	—	2.30	—	2.60	—	2.80	ns
		LFE2-35	—	2.30	—	2.60	—	2.80	ns
		LFE2-50	—	2.30	—	2.60	—	2.80	ns
		LFE2-70	—	2.30	—	2.60	—	2.80	ns
		LFE2M20	—	2.30	—	2.60	—	2.80	ns
		LFE2M35	—	2.30	—	2.60	—	2.80	ns
		LFE2M50	—	2.60	—	2.90	—	3.10	ns
		LFE2M70	—	2.60	—	2.90	—	3.10	ns
		LFE2M100	—	2.70	—	3.00	—	3.20	ns
t _{SUPLL}	Clock to Data Setup - PIO Input Register	LFE2-6	0.70	—	0.80	—	0.90	—	ns
		LFE2-12	0.70	—	0.80	—	0.90	—	ns
		LFE2-20	0.70	—	0.80	—	0.90	—	ns
		LFE2-35	0.70	—	0.80	—	0.90	—	ns
		LFE2-50	0.70	—	0.80	—	0.90	—	ns
		LFE2-70	0.70	—	0.80	—	0.90	—	ns
		LFE2M20	0.70	—	0.80	—	0.90	—	ns
		LFE2M35	0.70	—	0.80	—	0.90	—	ns
		LFE2M50	0.70	—	0.80	—	0.90	—	ns
		LFE2M70	0.70	—	0.80	—	0.90	—	ns
		LFE2M100	0.80	—	0.90	—	1.00	—	ns

LatticeECP2/M External Switching Characteristics⁹ (Continued)

Over Recommended Operating Conditions

Parameter	Description	Device	-7		-6		-5		Units
			Min.	Max.	Min.	Max.	Min.	Max.	
t _{HPLL}	Clock to Data Hold - PIO Input Register	LFE2-6	1.00	—	1.20	—	1.40	—	ns
		LFE2-12	1.00	—	1.20	—	1.40	—	ns
		LFE2-20	1.00	—	1.20	—	1.40	—	ns
		LFE2-35	1.00	—	1.20	—	1.40	—	ns
		LFE2-50	1.00	—	1.20	—	1.40	—	ns
		LFE2-70	1.00	—	1.20	—	1.40	—	ns
		LFE2M20	1.00	—	1.20	—	1.40	—	ns
		LFE2M35	1.00	—	1.20	—	1.40	—	ns
		LFE2M50	1.00	—	1.20	—	1.40	—	ns
		LFE2M70	1.00	—	1.20	—	1.40	—	ns
LFE2M100	1.00	—	1.20	—	1.40	—	ns		
t _{SU_DELPLL}	Clock to Data Setup - PIO Input Register with Data Input Delay	LFE2-6	1.80	—	2.00	—	2.20	—	ns
		LFE2-12	1.80	—	2.00	—	2.20	—	ns
		LFE2-20	1.80	—	2.00	—	2.20	—	ns
		LFE2-35	1.80	—	2.00	—	2.20	—	ns
		LFE2-50	1.80	—	2.00	—	2.20	—	ns
		LFE2-70	1.80	—	2.00	—	2.20	—	ns
		LFE2M20	1.80	—	2.00	—	2.20	—	ns
		LFE2M35	1.80	—	2.00	—	2.20	—	ns
		LFE2M50	1.90	—	2.10	—	2.30	—	ns
		LFE2M70	1.90	—	2.10	—	2.30	—	ns
LFE2M100	2.00	—	2.20	—	2.40	—	ns		
t _{H_DELPLL}	Clock to Data Hold - PIO Input Register with Input Data Delay	LFE2-6	0.00	—	0.00	—	0.00	—	ns
		LFE2-12	0.00	—	0.00	—	0.00	—	ns
		LFE2-20	0.00	—	0.00	—	0.00	—	ns
		LFE2-35	0.00	—	0.00	—	0.00	—	ns
		LFE2-50	0.00	—	0.00	—	0.00	—	ns
		LFE2-70	0.00	—	0.00	—	0.00	—	ns
		LFE2M20	0.00	—	0.00	—	0.00	—	ns
		LFE2M35	0.00	—	0.00	—	0.00	—	ns
		LFE2M50	0.00	—	0.00	—	0.00	—	ns
		LFE2M70	0.00	—	0.00	—	0.00	—	ns
LFE2M100	0.00	—	0.00	—	0.00	—	ns		
DDR I/O Pin Parameters²									
t _{DVADQ}	Data Valid After DQS (DDR Read)	ECP2/M	—	0.225	—	0.225	—	0.225	UI
t _{DVEDQ}	Data Hold After DQS (DDR Read)	ECP2/M	0.640	—	0.640	—	0.640	—	UI
t _{DQVBS}	Data Valid Before DQS (DDR Write)	ECP2/M	0.250	—	0.250	—	0.250	—	UI
t _{DQVAS}	Data Valid After DQS (DDR Write)	ECP2/M	0.250	—	0.250	—	0.250	—	UI
f _{MAX_DDR}	DDR Clock Frequency ⁶	ECP2/M	95	200	95	166	95	133	MHz
DDR2 I/O Pin Parameters³									
t _{DVADQ}	Data Valid After DQS (DDR Read)	ECP2/M	—	0.225	—	0.225	—	0.225	UI
t _{DVEDQ}	Data Hold After DQS (DDR Read)	ECP2/M	0.640	—	0.640	—	0.640	—	UI

LatticeECP2/M External Switching Characteristics⁹ (Continued)

Over Recommended Operating Conditions

Parameter	Description	Device	-7		-6		-5		Units
			Min.	Max.	Min.	Max.	Min.	Max.	
t _{DQVBS}	Data Valid Before DQS (DDR Write)	ECP2/M	0.250	—	0.250	—	0.250	—	UI
t _{DQVAS}	Data Valid After DQS (DDR Write)	ECP2/M	0.250	—	0.250	—	0.250	—	UI
f _{MAX_DDR2}	DDR Clock Frequency	ECP2/M	133	266	133	200	133	166	MHz
SPI4.2 I/O Pin Parameters Static Alignment^{4, 8, 11}									
	Maximum Data Rate	ECP2-20	—	750	—	622	—	622	Mbps
		ECP2-35	—	750	—	622	—	622	Mbps
		ECP2-50	—	750	—	622	—	622	Mbps
		ECP2-70	—	750	—	622	—	622	Mbps
		ECP2M20	—	622	—	622	—	622	Mbps
		ECP2M35	—	622	—	622	—	622	Mbps
		ECP2M50	—	622	—	622	—	622	Mbps
		ECP2M70	—	622	—	622	—	622	Mbps
		ECP2M100	—	622	—	622	—	622	Mbps
t _{DVACLKSPI}	Data Valid After CLK (Receive)	ECP2-20	—	0.25	—	0.25	—	0.25	UI
		ECP2-35	—	0.25	—	0.25	—	0.25	UI
		ECP2-50	—	0.25	—	0.25	—	0.25	UI
		ECP2-70	—	0.25	—	0.25	—	0.25	UI
		ECP2M20	—	0.21	—	0.21	—	0.21	UI
		ECP2M35	—	0.21	—	0.21	—	0.21	UI
		ECP2M50	—	0.21	—	0.21	—	0.21	UI
		ECP2M70	—	0.21	—	0.21	—	0.21	UI
		ECP2M100	—	0.21	—	0.21	—	0.21	UI
t _{DVECLKSPI}	Data Hold After CLK (Receive)	ECP2-20	0.75	—	0.75	—	0.75	—	UI
		ECP2-35	0.75	—	0.75	—	0.75	—	UI
		ECP2-50	0.75	—	0.75	—	0.75	—	UI
		ECP2-70	0.75	—	0.75	—	0.75	—	UI
		ECP2M20	0.79	—	0.79	—	0.79	—	UI
		ECP2M35	0.79	—	0.79	—	0.79	—	UI
		ECP2M50	0.79	—	0.79	—	0.79	—	UI
		ECP2M70	0.79	—	0.79	—	0.79	—	UI
		ECP2M100	0.79	—	0.79	—	0.79	—	UI
t _{DIASPI}	Data Invalid After Clock (Transmit)	ECP2-20	—	280	—	280	—	280	ps
		ECP2-35	—	280	—	280	—	280	ps
		ECP2-50	—	280	—	280	—	280	ps
		ECP2-70	—	280	—	280	—	280	ps
		ECP2M20	—	230	—	230	—	230	ps
		ECP2M35	—	230	—	230	—	230	ps
		ECP2M50	—	230	—	230	—	230	ps
		ECP2M70	—	230	—	230	—	230	ps
		ECP2M100	—	230	—	230	—	230	ps

LatticeECP2/M External Switching Characteristics⁹ (Continued)

Over Recommended Operating Conditions

Parameter	Description	Device	-7		-6		-5		Units
			Min.	Max.	Min.	Max.	Min.	Max.	
t _{DIBSPI}	Data Invalid Before Clock (Transmit)	ECP2-20	—	280	—	280	—	280	ps
		ECP2-35	—	280	—	280	—	280	ps
		ECP2-50	—	280	—	280	—	280	ps
		ECP2-70	—	280	—	280	—	280	ps
		ECP2M20	—	230	—	230	—	230	ps
		ECP2M35	—	230	—	230	—	230	ps
		ECP2M50	—	230	—	230	—	230	ps
		ECP2M70	—	230	—	230	—	230	ps
		ECP2M100	—	230	—	230	—	230	ps
XGMII I/O Pin Parameters (312 Mbps)⁵									
t _{SUXGMII}	Data Setup Before Read Clock	ECP2/M	480	—	480	—	480	—	ps
t _{HXGMII}	Data Hold After Read Clock	ECP2/M	480	—	480	—	480	—	ps
t _{DVBCKXGMII}	Data Valid Before Clock	ECP2/M	960	—	960	—	960	—	ps
t _{DVACKXGMII}	Data Valid After Clock	ECP2/M	960	—	960	—	960	—	ps
Primary									
f _{MAX_PRI} ⁷	Frequency for Primary Clock Tree	ECP2/M	—	420	—	357	—	311	MHz
t _{W_PRI}	Clock Pulse Width for Primary Clock	ECP2/M	0.95	—	1.19	—	2.00	—	ns
t _{SKEW_PRI}	Primary Clock Skew Within a Bank	ECP2/M	—	300	—	360	—	420	ps
Edge Clock									
f _{MAX_EDGE} ⁷	Frequency for Edge Clock	ECP2/M	—	420	—	357	—	311	MHz
t _{W_EDGE}	Clock Pulse Width for Edge Clock	ECP2/M	0.95	—	1.19	—	2.00	—	ns
t _{SKEW_EDGE}	Edge Clock Skew Within an Edge of the Device	ECP2/M	—	300	—	360	—	420	ps

1. General timing numbers based on LVCMOS 2.5, 12mA, 0pf load.

2. DDR timing numbers based on SSTL25 for BGA packages only.

3. DDR2 timing numbers based on SSTL18 for BGA packages only.

4. SPI4.2 and SF14 timing numbers based on LVDS25 for BGA packages only.

5. XGMII timing numbers based on HSTL class I. A corresponding left/right dedicated clock buffer is used when using the SPI4.2 interface to the left or right edge of the device. For SPI4.2 mode, the software tool will help in selecting the appropriate clock buffer.

6. IP will be used to support DDR and DDR2 memory data rates down to 95MHz. This approach uses a free-running clock and PFU register to sample the data instead of the hardwired DDR memory interface.

7. Using the LVDS I/O standard.

8. ECP2-6 and ECP2-12 do not support SPI4.2

9. The AC numbers do not apply to PCLK6 and PCLK7.

10. Applies to CLKOP only.

11. Please refer to technical note TN1159, LatticeECP2M Pin Assignment Recommendations for best performance.

Timing v.A 0.11

Figure 3-6. SPI4.2 Parameters

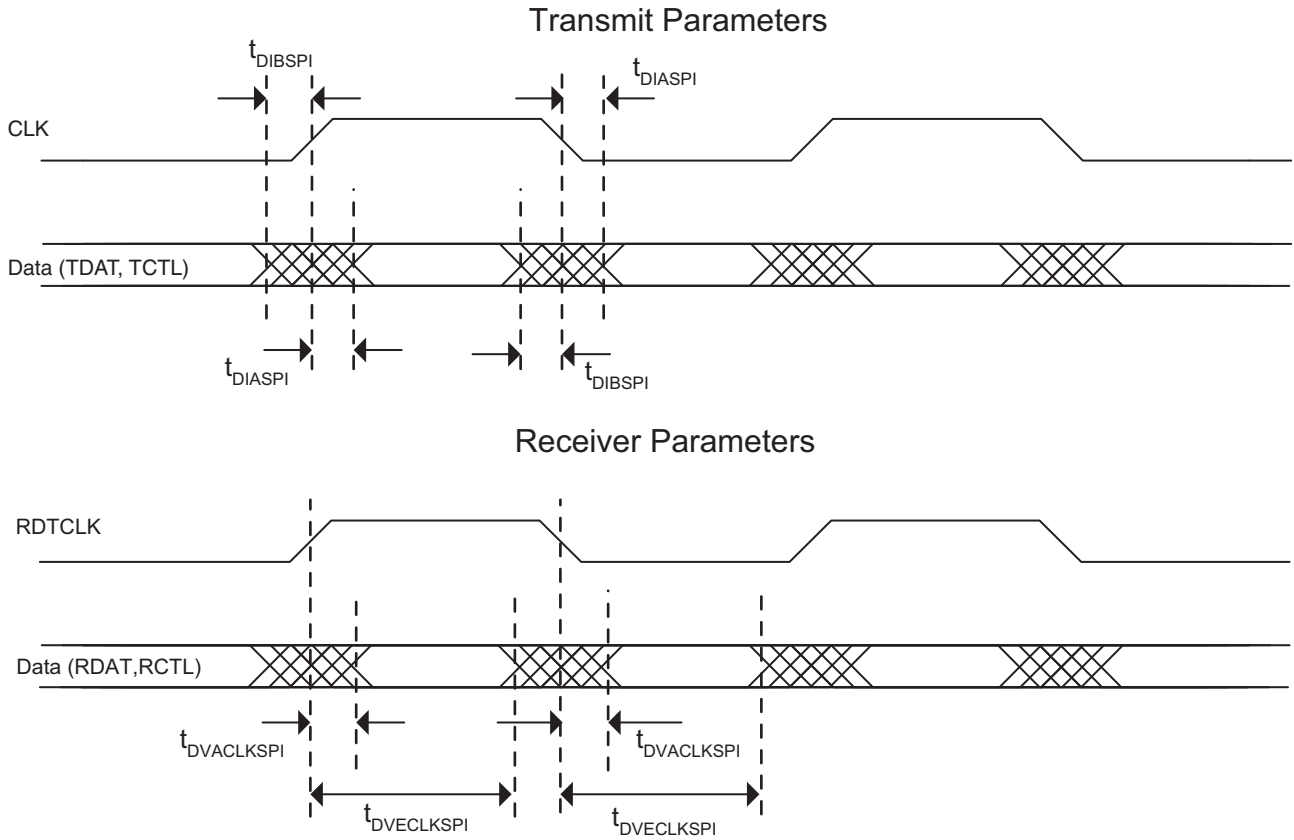

Figure 3-7. DDR and DDR2 Parameters

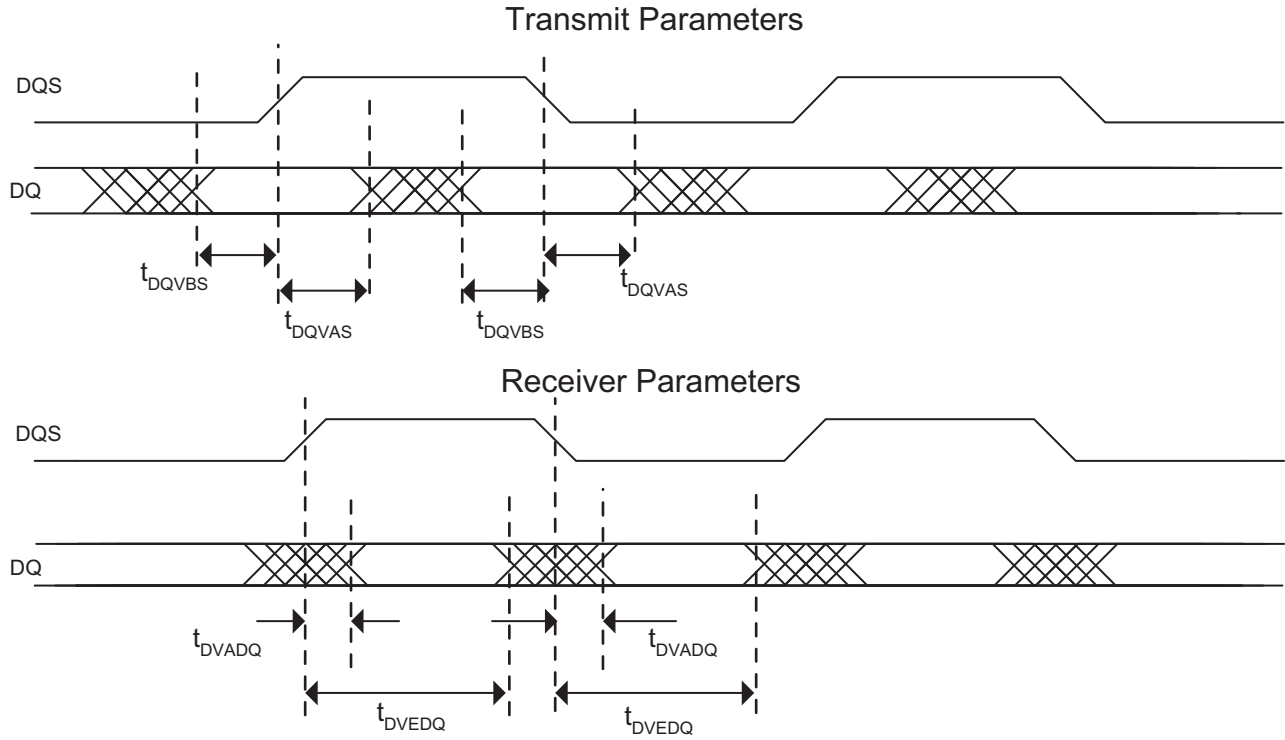
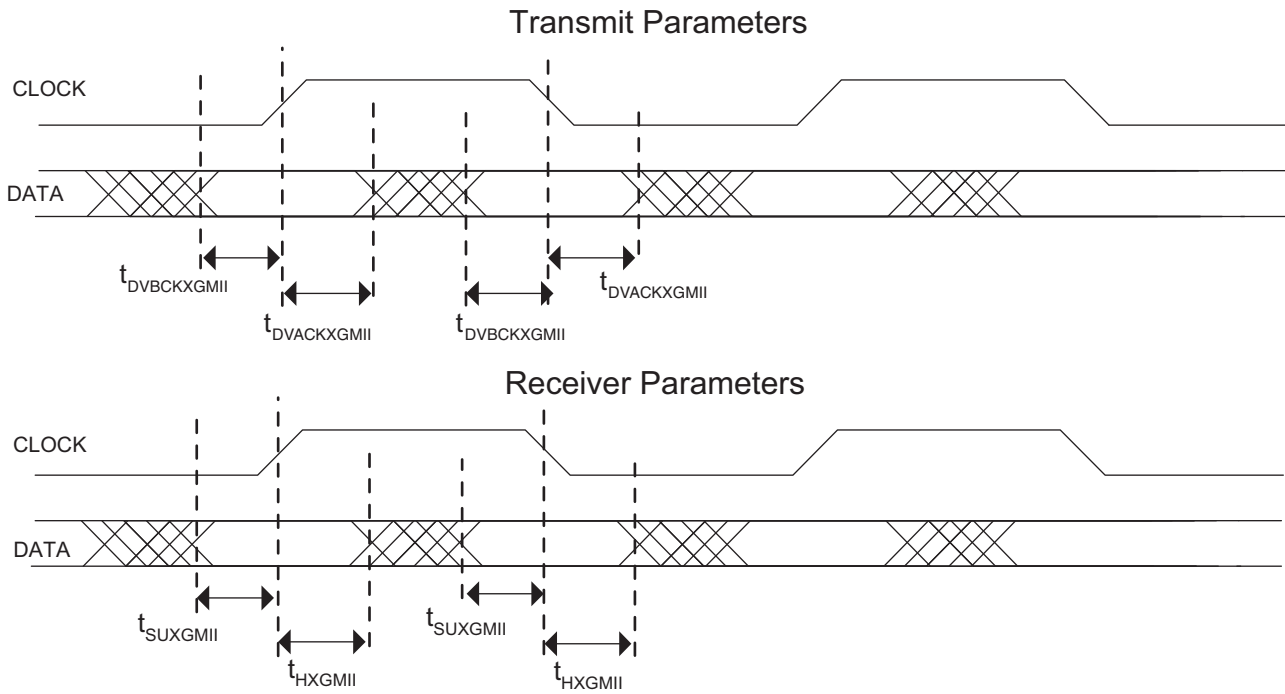

Figure 3-8. XGMII Parameters



LatticeECP2/M Internal Switching Characteristics¹

Over Recommended Operating Conditions

Parameter	Description	-7		-6		-5		Units
		Min.	Max.	Min.	Max.	Min.	Max.	
PFU/PFF Logic Mode Timing								
t _{LUT4_PFU}	LUT4 delay (A to D inputs to F output)	—	0.180	—	0.198	—	0.216	ns
t _{LUT6_PFU}	LUT6 delay (A to D inputs to OFX output)	—	0.304	—	0.331	—	0.358	ns
t _{LSR_PFU}	Set/Reset to output of PFU (Asynchronous)	—	0.600	—	0.655	—	0.711	ns
t _{SUM_PFU}	Clock to Mux (M0,M1) Input Setup Time	0.128	—	0.129	—	0.129	—	ns
t _{HM_PFU}	Clock to Mux (M0,M1) Input Hold Time	-0.051	—	-0.049	—	-0.046	—	ns
t _{SUD_PFU}	Clock to D input setup time	0.061	—	0.071	—	0.081	—	ns
t _{HD_PFU}	Clock to D input hold time	0.002	—	0.003	—	0.003	—	ns
t _{CK2Q_PFU}	Clock to Q delay, (D-type Register Configuration)	—	0.285	—	0.309	—	0.333	ns
PFU Dual Port Memory Mode Timing								
t _{CORAM_PFU}	Clock to Output (F Port)	—	0.902	—	1.083	—	1.263	ns
t _{SUDATA_PFU}	Data Setup Time	-0.172	—	-0.205	—	-0.238	—	ns
t _{HDATA_PFU}	Data Hold Time	0.199	—	0.235	—	0.271	—	ns
t _{SUADDR_PFU}	Address Setup Time	-0.245	—	-0.284	—	-0.323	—	ns
t _{HADDR_PFU}	Address Hold Time	0.246	—	0.285	—	0.324	—	ns
t _{SUWREN_PFU}	Write/Read Enable Setup Time	-0.122	—	-0.145	—	-0.168	—	ns
t _{HWREN_PFU}	Write/Read Enable Hold Time	0.132	—	0.156	—	0.180	—	ns
PIC Timing								
PIO Input/Output Buffer Timing								
t _{IN_PIO}	Input Buffer Delay (LVCMOS25)	—	0.613	—	0.681	—	0.749	ns
t _{OUT_PIO}	Output Buffer Delay (LVCMOS25)	—	1.115	—	1.115	—	1.343	ns
IOLOGIC Input/Output Timing								
t _{SUI_PIO}	Input Register Setup Time (Data Before Clock)	0.596	—	0.645	—	0.694	—	ns
t _{HI_PIO}	Input Register Hold Time (Data after Clock)	-0.570	—	-0.614	—	-0.658	—	ns
t _{COO_PIO}	Output Register Clock to Output Delay	—	0.61	—	0.66	—	0.72	ns
t _{SUCE_PIO}	Input Register Clock Enable Setup Time	0.032	—	0.037	—	0.041	—	ns
t _{HCE_PIO}	Input Register Clock Enable Hold Time	-0.022	—	-0.025	—	-0.028	—	ns
t _{SULSR_PIO}	Set/Reset Setup Time	0.184	—	0.201	—	0.217	—	ns
t _{HLSR_PIO}	Set/Reset Hold Time	-0.080	—	-0.086	—	-0.093	—	ns
EBR Timing								
t _{CO_EBR}	Clock (Read) to output from Address or Data	—	2.51	—	2.75	—	2.99	ns
t _{COO_EBR}	Clock (Write) to output from EBR output Register	—	0.33	—	0.36	—	0.39	ns
t _{SUDATA_EBR}	Setup Data to EBR Memory	-0.157	—	-0.181	—	-0.205	—	ns
t _{HDATA_EBR}	Hold Data to EBR Memory	0.173	—	0.195	—	0.217	—	ns
t _{SUADDR_EBR}	Setup Address to EBR Memory	-0.115	—	-0.130	—	-0.145	—	ns
t _{HADDR_EBR}	Hold Address to EBR Memory	0.138	—	0.155	—	0.172	—	ns
t _{SUWREN_EBR}	Setup Write/Read Enable to PFU Memory	-0.128	—	-0.149	—	-0.170	—	ns

LatticeECP2/M Internal Switching Characteristics¹ (Continued)

Over Recommended Operating Conditions

Parameter	Description	-7		-6		-5		Units
		Min.	Max.	Min.	Max.	Min.	Max.	
t _{HWREN_EBR}	Hold Write/Read Enable to PFU Memory	0.139	—	0.156	—	0.173	—	ns
t _{SUCE_EBR}	Clock Enable Setup Time to EBR Output Register	0.123	—	0.134	—	0.145	—	ns
t _{HCE_EBR}	Clock Enable Hold Time to EBR Output Register	-0.081	—	-0.090	—	-0.100	—	ns
t _{RSTO_EBR}	Reset To Output Delay Time from EBR Output Register	—	1.03	—	1.15	—	1.26	ns
t _{SUBE_EBR}	Byte Enable Set-Up Time to EBR Output Register	-0.115	—	-0.130	—	-0.145	—	ns
t _{HBE_EBR}	Byte Enable Hold Time to EBR Output Register	0.138	—	0.155	—	0.172	—	ns
GPLL Parameters								
t _{RSTREC_GPLL}	Reset Recovery to Rising Clock	1.00	—	1.00	—	1.00	—	ns
SPLL Parameters								
t _{RSTREC_SPLL}	Reset Recovery to Rising Clock	1.00	—	1.00	—	1.00	—	ns
DSP Block Timing^{2,3}								
t _{SUI_DSP}	Input Register Setup Time	0.12	—	0.13	—	0.14	—	ns
t _{HI_DSP}	Input Register Hold Time	0.02	—	-0.01	—	-0.03	—	ns
t _{SUP_DSP}	Pipeline Register Setup Time	2.18	—	2.42	—	2.66	—	ns
t _{IHP_DSP}	Pipeline Register Hold Time	-0.68	—	-0.77	—	-0.86	—	ns
t _{SUO_DSP}	Output Register Setup Time	4.26	—	4.71	—	5.16	—	ns
t _{HO_DSP}	Output Register Hold Time	-1.25	—	-1.40	—	-1.54	—	ns
t _{COI_DSP}	Input Register Clock to Output Time	—	3.92	—	4.30	—	4.68	ns
t _{COP_DSP}	Pipeline Register Clock to Output Time	—	1.87	—	1.98	—	2.08	ns
t _{COO_DSP}	Output Register Clock to Output Time	—	0.50	—	0.52	—	0.55	ns
t _{SUADDSUB}	AddSub Input Register Setup Time	-0.24	—	-0.26	—	-0.28	—	ns
t _{HADDSUB}	AddSub Input Register Hold Time	0.27	—	0.29	—	0.32	—	ns

1. Internal parameters are characterized but not tested on every device.

2. These parameters apply to LatticeECP devices only.

3. DSP Block is configured in Multiply Add/Sub 18x18 Mode.

Timing v.A 0.11

Timing Diagrams

Figure 3-9. Read/Write Mode (Normal)

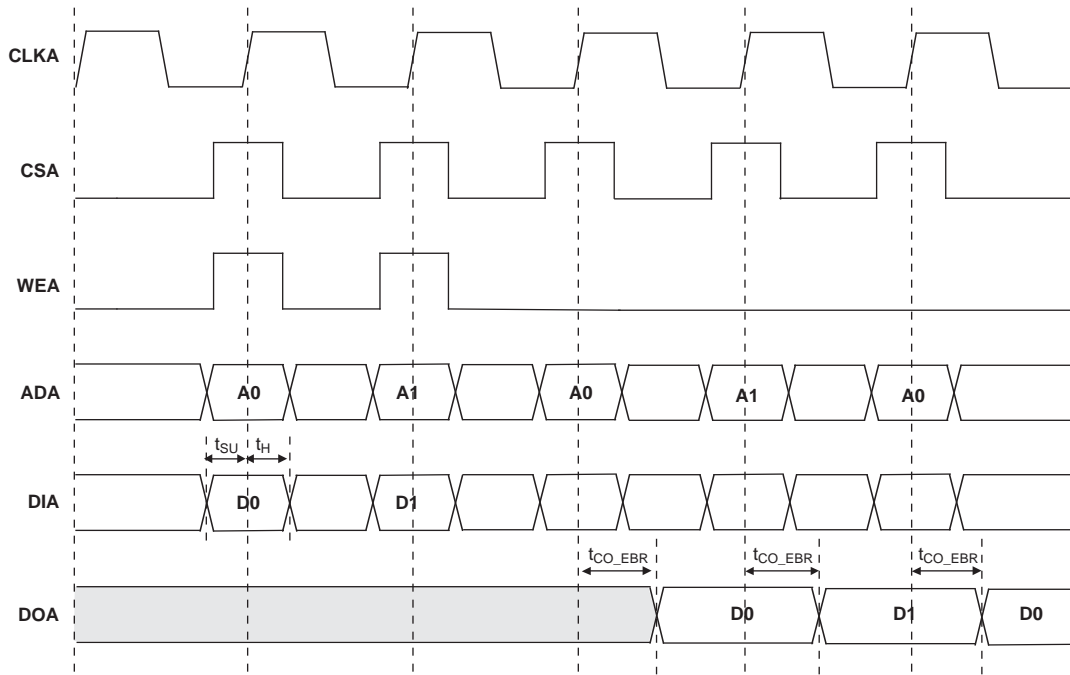

Note: Input data and address are registered at the positive edge of the clock and output data appears after the positive edge of the clock.

Figure 3-10. Read/Write Mode with Input and Output Registers

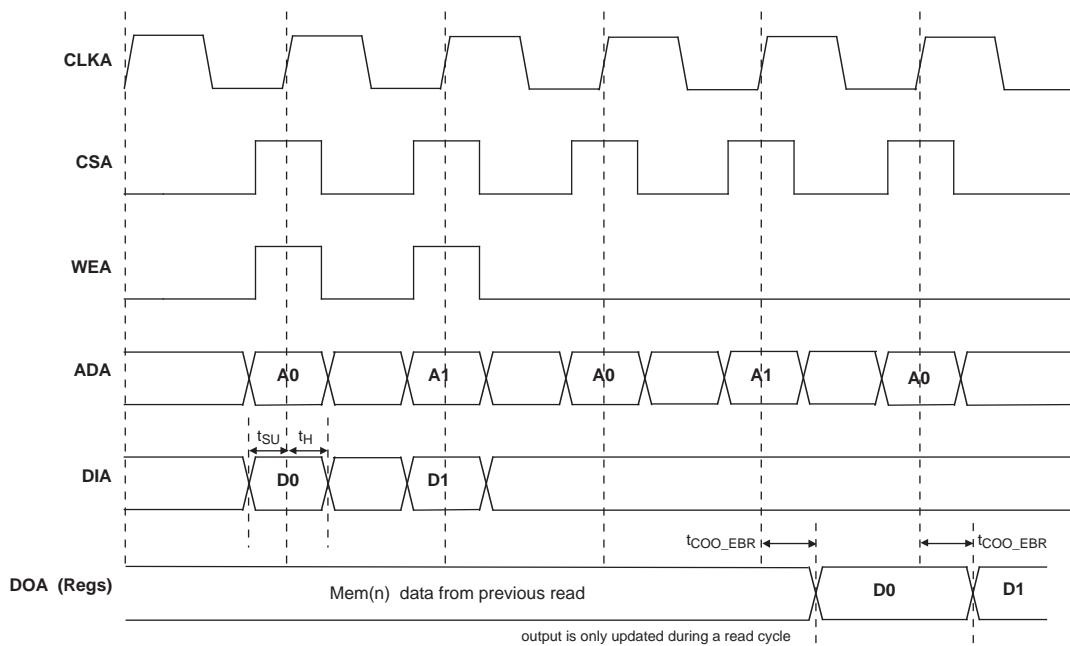
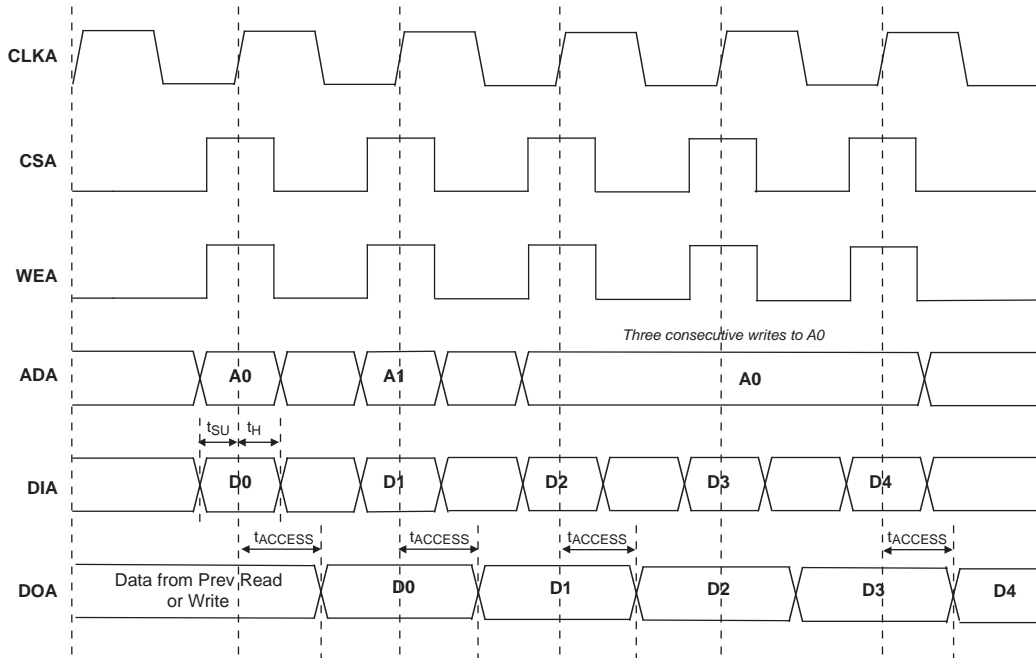

Figure 3-11. Write Through (SP Read/Write on Port A, Input Registers Only)



Note: Input data and address are registered at the positive edge of the clock and output data appears after the positive edge of the clock.

LatticeECP2/M Family Timing Adders^{1, 2, 3}

Over Recommended Operating Conditions

Buffer Type	Description	-7	-6	-5	Units
Input Adjusters					
LVDS25	LVDS	-0.04	-0.02	0.00	ns
BLVDS25	BLVDS	-0.04	-0.09	-0.15	ns
MLVDS	LVDS	-0.15	-0.15	-0.15	ns
RSDS	RSDS	-0.15	-0.15	-0.15	ns
LVPECL33	LVPECL	0.16	0.15	0.13	ns
HSTL18_I	HSTL_18 class I	0.01	-0.01	-0.04	ns
HSTL18_II	HSTL_18 class II	0.01	-0.01	-0.04	ns
HSTL18D_I	Differential HSTL 18 class I	0.01	-0.01	-0.04	ns
HSTL18D_II	Differential HSTL 18 class II	0.01	-0.01	-0.04	ns
HSTL15_I	HSTL_15 class I	0.01	-0.01	-0.04	ns
HSTL15D_I	Differential HSTL 15 class I	0.01	-0.01	-0.04	ns
SSTL33_I	SSTL_3 class I	-0.03	-0.07	-0.10	ns
SSTL33_II	SSTL_3 class II	-0.03	-0.07	-0.10	ns
SSTL33D_I	Differential SSTL_3 class I	-0.03	-0.07	-0.10	ns
SSTL33D_II	Differential SSTL_3 class II	-0.03	-0.07	-0.10	ns
SSTL25_I	SSTL_2 class I	-0.04	-0.07	-0.10	ns
SSTL25_II	SSTL_2 class II	-0.04	-0.07	-0.10	ns
SSTL25D_I	Differential SSTL_2 class I	-0.04	-0.07	-0.10	ns
SSTL25D_II	Differential SSTL_2 class II	-0.04	-0.07	-0.10	ns
SSTL18_I	SSTL_18 class I	-0.01	-0.04	-0.07	ns
SSTL18_II	SSTL_18 class II	-0.01	-0.04	-0.07	ns
SSTL18D_I	Differential SSTL_18 class I	-0.01	-0.04	-0.07	ns
SSTL18D_II	Differential SSTL_18 class II	-0.01	-0.04	-0.07	ns
LVTTTL33	LVTTTL	-0.16	-0.16	-0.16	ns
LVC MOS33	LVC MOS 3.3	-0.08	-0.12	-0.16	ns
LVC MOS25	LVC MOS 2.5	0.00	0.00	0.00	ns
LVC MOS18	LVC MOS 1.8	-0.16	-0.17	-0.17	ns
LVC MOS15	LVC MOS 1.5	-0.14	-0.14	-0.14	ns
LVC MOS12	LVC MOS 1.2	-0.04	-0.01	0.01	ns
PCI33	PCI	-0.08	-0.12	-0.16	ns
Output Adjusters					
LVDS25E	LVDS 2.5 E ⁴	0.25	0.19	0.13	ns
LVDS25	LVDS 2.5	0.10	0.13	0.17	ns
BLVDS25	BLVDS 2.5	0.00	-0.01	-0.03	ns
MLVDS	MLVDS 2.5 ⁴	0.00	-0.01	-0.03	ns
RSDS	RSDS 2.5 ⁴	0.25	0.19	0.13	ns
LVPECL33	LVPECL 3.3 ⁴	-0.02	-0.04	-0.06	ns
HSTL18_I	HSTL_18 class I 8mA drive	-0.19	-0.22	-0.25	ns
HSTL18_II	HSTL_18 class II	-0.30	-0.34	-0.37	ns
HSTL18D_I	Differential HSTL 18 class I 8mA drive	-0.19	-0.22	-0.25	ns
HSTL18D_II	Differential HSTL 18 class II	-0.30	-0.34	-0.37	ns

LatticeECP2/M Family Timing Adders^{1, 2, 3} (Continued)

Over Recommended Operating Conditions

Buffer Type	Description	-7	-6	-5	Units
HSTL15_I	HSTL_15 class I 4mA drive	-0.22	-0.25	-0.27	ns
HSTL15D_I	Differential HSTL 15 class I 4mA drive	-0.22	-0.25	-0.27	ns
SSTL33_I	SSTL_3 class I	-0.12	-0.15	-0.18	ns
SSTL33_II	SSTL_3 class II	-0.20	-0.23	-0.27	ns
SSTL33D_I	Differential SSTL_3 class I	-0.12	-0.15	-0.18	ns
SSTL33D_II	Differential SSTL_3 class II	-0.20	-0.23	-0.27	ns
SSTL25_I	SSTL_2 class I 8mA drive	-0.16	-0.19	-0.22	ns
SSTL25_II	SSTL_2 class II 16mA drive	-0.19	-0.22	-0.25	ns
SSTL25D_I	Differential SSTL_2 class I 8mA drive	-0.16	-0.19	-0.22	ns
SSTL25D_II	Differential SSTL_2 class II 16mA drive	-0.19	-0.22	-0.25	ns
SSTL18_I	SSTL_1.8 class I	-0.14	-0.17	-0.20	ns
SSTL18_II	SSTL_1.8 class II 8mA drive	-0.20	-0.23	-0.25	ns
SSTL18D_I	Differential SSTL_1.8 class I	-0.14	-0.17	-0.20	ns
SSTL18D_II	Differential SSTL_1.8 class II 8mA drive	-0.20	-0.23	-0.25	ns
LVTTTL33_4mA	LVTTTL 4mA drive	0.52	0.60	0.68	ns
LVTTTL33_8mA	LVTTTL 8mA drive	0.06	0.08	0.09	ns
LVTTTL33_12mA	LVTTTL 12mA drive	0.04	0.04	0.05	ns
LVTTTL33_16mA	LVTTTL 16mA drive	0.03	0.02	0.02	ns
LVTTTL33_20mA	LVTTTL 20mA drive	-0.09	-0.09	-0.10	ns
LVC MOS33_4mA	LVC MOS 3.3 4mA drive, fast slew rate	0.52	0.60	0.68	ns
LVC MOS33_8mA	LVC MOS 3.3 8mA drive, fast slew rate	0.06	0.08	0.09	ns
LVC MOS33_12mA	LVC MOS 3.3 12mA drive, fast slew rate	0.04	0.04	0.05	ns
LVC MOS33_16mA	LVC MOS 3.3 16mA drive, fast slew rate	0.03	0.02	0.02	ns
LVC MOS33_20mA	LVC MOS 3.3 20mA drive, fast slew rate	-0.09	-0.09	-0.10	ns
LVC MOS25_4mA	LVC MOS 2.5 4mA drive, fast slew rate	0.41	0.47	0.53	ns
LVC MOS25_8mA	LVC MOS 2.5 8mA drive, fast slew rate	0.01	0.01	0.00	ns
LVC MOS25_12mA	LVC MOS 2.5 12mA drive, fast slew rate	0.00	0.00	0.00	ns
LVC MOS25_16mA	LVC MOS 2.5 16mA drive, fast slew rate	0.04	0.04	0.04	ns
LVC MOS25_20mA	LVC MOS 2.5 20mA drive, fast slew rate	-0.09	-0.10	-0.11	ns
LVC MOS18_4mA	LVC MOS 1.8 4mA drive, fast slew rate	0.37	0.40	0.43	ns
LVC MOS18_8mA	LVC MOS 1.8 8mA drive, fast slew rate	0.10	0.12	0.13	ns
LVC MOS18_12mA	LVC MOS 1.8 12mA drive, fast slew rate	-0.02	-0.02	-0.02	ns
LVC MOS18_16mA	LVC MOS 1.8 16mA drive, fast slew rate	-0.02	-0.03	-0.03	ns
LVC MOS15_4mA	LVC MOS 1.5 4mA drive, fast slew rate	0.29	0.31	0.32	ns
LVC MOS15_8mA	LVC MOS 1.5 8mA drive, fast slew rate	0.05	0.05	0.06	ns
LVC MOS12_2mA	LVC MOS 1.2 2mA drive, fast slew rate	0.58	0.69	0.79	ns
LVC MOS12_6mA	LVC MOS 1.2 6mA drive, fast slew rate	0.13	0.19	0.26	ns
LVC MOS33_4mA	LVC MOS 3.3 4mA drive, slow slew rate	2.17	2.44	2.71	ns
LVC MOS33_8mA	LVC MOS 3.3 8mA drive, slow slew rate	2.50	2.67	2.83	ns
LVC MOS33_12mA	LVC MOS 3.3 12mA drive, slow slew rate	1.72	1.88	2.05	ns
LVC MOS33_16mA	LVC MOS 3.3 16mA drive, slow slew rate	1.64	1.63	1.62	ns
LVC MOS33_20mA	LVC MOS 3.3 20mA drive, slow slew rate	1.33	1.36	1.39	ns

LatticeECP2/M Family Timing Adders^{1, 2, 3} (Continued)

Over Recommended Operating Conditions

Buffer Type	Description	-7	-6	-5	Units
LVC MOS25_4mA	LVC MOS 2.5 4mA drive, slow slew rate	2.18	2.26	2.33	ns
LVC MOS25_8mA	LVC MOS 2.5 8mA drive, slow slew rate	2.19	2.35	2.51	ns
LVC MOS25_12mA	LVC MOS 2.5 12mA drive, slow slew rate	1.50	1.66	1.82	ns
LVC MOS25_16mA	LVC MOS 2.5 16mA drive, slow slew rate	1.60	1.59	1.58	ns
LVC MOS25_20mA	LVC MOS 2.5 20mA drive, slow slew rate	1.43	1.39	1.34	ns
LVC MOS18_4mA	LVC MOS 1.8 4mA drive, slow slew rate	2.22	2.27	2.32	ns
LVC MOS18_8mA	LVC MOS 1.8 8mA drive, slow slew rate	1.93	2.08	2.23	ns
LVC MOS18_12mA	LVC MOS 1.8 12mA drive, slow slew rate	1.43	1.51	1.58	ns
LVC MOS18_16mA	LVC MOS 1.8 16mA drive, slow slew rate	1.47	1.46	1.45	ns
LVC MOS15_4mA	LVC MOS 1.5 4mA drive, slow slew rate	2.32	2.38	2.43	ns
LVC MOS15_8mA	LVC MOS 1.5 8mA drive, slow slew rate	1.84	1.98	2.12	ns
LVC MOS12_2mA	LVC MOS 1.2 2mA drive, slow slew rate	2.52	2.63	2.74	ns
LVC MOS12_6mA	LVC MOS 1.2 6mA drive, slow slew rate	1.69	1.83	1.96	ns
PCI33	PCI33	0.04	0.04	0.04	ns

1. Timing Adders are characterized but not tested on every device.
 2. LVC MOS timing measured with the load specified in Switching Test Condition table.
 3. All other standards tested according to the appropriate specifications.
 4. These timing adders are measured with the recommended resistor values.
- Timing v.A 0.11

sysCLOCK GPLL Timing**Over Recommended Operating Conditions**

Parameter	Description	Conditions	Min.	Typ.	Max.	Units
f _{IN}	Input Clock Frequency (CLKI, CLKFB)	Without external capacitor	20	—	420	MHz
		With external capacitor ^{5, 6}	2	—	420	MHz
f _{OUT}	Output Clock Frequency (CLKOP, CLKOS)	Without external capacitor	20	—	420	MHz
		With external capacitor ⁵	5	—	50	MHz
f _{OUT2}	K-Divider Output Frequency (CLKOK)	Without external capacitor	0.156	—	210	MHz
		With external capacitor ⁵	0.039	—	25	MHz
f _{VCO}	PLL VCO Frequency		640	—	1280	MHz
f _{PDF}	Phase Detector Input Frequency	Without external capacitor	20	—	420	MHz
		With external capacitor ^{5, 6}	2	—	50	MHz
AC Characteristics						
t _{DT}	Output Clock Duty Cycle	Default duty cycle selected ³	45	50	55	%
t _{PH} ⁴	Output Phase Accuracy		—	—	±0.05	UI
t _{OPJIT} ¹	Output Clock Period Jitter	f _{OUT} ≥ 100 MHz	—	—	±125	ps
		50 ≤ f _{OUT} < 100 MHz	—	—	0.025	UIPP
		f _{OUT} < 50 MHz	—	—	0.04	UIPP
t _{SK}	Input Clock to Output Clock Skew	N/M = integer	—	—	±250	ps
t _W	Output Clock Pulse Width	At 90% or 10%	1	—	—	ns
t _{LOCK} ²	PLL Lock-in Time	Without external capacitor	—	—	150	μs
		With external capacitor ⁵	—	—	500	μs
t _{PA}	Programmable Delay Unit		85	130	360	ps
t _{IPJIT}	Input Clock Period Jitter		—	—	±200	ps
t _{FBKDLY}	External Feedback Delay		—	—	10	ns
t _{HI}	Input Clock High Time	90% to 90%	0.5	—	—	ns
t _{LO}	Input Clock Low Time	10% to 10%	0.5	—	—	ns
t _{RST}	RST Pulse Width (RESETM/RESETK)		15	—	—	ns
	Reset Signal Pulse Width (CNTRST)	Without external capacitor	500	—	—	ns
		With external capacitor ⁵	20	—	—	μs

1. Jitter sample is taken over 10,000 samples of the primary PLL output with clean reference clock and no additional I/O pins toggling.

2. Output clock is valid after t_{LOCK} for PLL reset and dynamic delay adjustment.

3. Using LVDS output buffers.

4. Relative to CLKOP.

5. Value of external capacitor: 5.6 nF ±20%, NPO dielectric, ceramic chip capacitor, 1206 or smaller package, connected to PLLCAP pin.

6. f_{OUT} (max) = f_{IN} * 10 for f_{IN} < 5MHz.

Timing v.A 0.11

sysCLOCK SPLL Timing**Over Recommended Operating Conditions**

Parameter	Description	Conditions	Min.	Typ.	Max.	Units
f _{IN}	Input Clock Frequency (CLKI, CLKFB)	Without external capacitor	33	—	420	MHz
		With external capacitor ^{5, 6}	2	—	420	MHz
f _{OUT}	Output Clock Frequency (CLKOP, CLKOS)	Without external capacitor	33	—	420	MHz
		With external capacitor ⁵	5	—	50	MHz
f _{OUT2}	K-Divider Output Frequency (CLKOK)	Without external capacitor	0.258	—	210	MHz
		With external capacitor ⁵	0.039	—	25	MHz
f _{VCO}	PLL VCO Frequency		640	—	1280	MHz
f _{PDF}	Phase Detector Input Frequency	Without external capacitor	33	—	420	MHz
		With external capacitor ⁶	2	—	50	MHz
AC Characteristics						
t _{DT}	Output Clock Duty Cycle	Default Duty Cycle Selected ³	45	50	55	%
t _{PH} ⁴	Output Phase Accuracy		—	—	±0.05	UI
t _{OPJIT} ¹	Output Clock Period Jitter	f _{OUT} ≥ 100 MHz	—	—	±125	ps
		50 ≤ f _{OUT} < 100 MHz	—	—	0.025	UIPP
		f _{OUT} < 50 MHz	—	—	0.04	UIPP
t _{SK}	Input Clock to Output Clock Skew	Divider Ratio = Integer	—	—	±250	ps
t _W	Output Clock Pulse Width	At 90% or 10%	1	—	—	ns
t _{LOCK} ²	PLL Lock-in Time	Without external capacitor	—	—	150	μs
		With external capacitor ⁵	—	—	500	μs
t _{IPJIT}	Input Clock Period Jitter		—	—	±200	ps
t _{FBKDL}	External Feedback Delay		—	—	10	ns
t _{HI}	Input Clock High Time	90% to 90%	0.5	—	—	ns
t _{LO}	Input Clock Low Time	10% to 10%	0.5	—	—	ns
t _{RST}	RST Pulse Width (RESETM/RESETK)		15	—	—	ns
	Reset Signal Pulse Width (CNTRST)	Without external capacitor	500	—	—	ns
		With external capacitor ⁵	20	—	—	μs

1. Jitter sample is taken over 10,000 samples of the primary PLL output with clean reference clock and no additional I/O pins toggling.

2. Output clock is valid after t_{LOCK} for PLL reset and dynamic delay adjustment.

3. Using LVDS output buffers.

4. Phase accuracy of CLKOS compared to CLKOP.

5. Value of external capacitor: 5.6 nF ±20%, NPO dielectric, ceramic chip capacitor, 1206 or smaller package, connected to PLLCAP pin.

6. f_{OUT} (max) = f_{IN} * 10 for f_{IN} < 5MHz.

Timing v.A 0.11

DLL Timing**Over Recommended Operating Conditions**

Parameter	Description	Min.	Typ.	Max.	Units
f_{REF}	Input reference clock frequency (on-chip or off-chip)	100	—	500	MHz
f_{FB}	Feedback clock frequency (on-chip or off-chip)	100	—	500	MHz
f_{CLKOP}^1	Output clock frequency, CLKOP	100	—	500	MHz
f_{CLKOS}^2	Output clock frequency, CLKOS	25	—	500	MHz
t_{PJIT}	Output clock period jitter (clean input)		—	250	ps p-p
t_{CYJIT}	Output clock cycle to cycle jitter (clean input)			250	ps p-p
t_{DUTY}	Output clock duty cycle (at 50% levels, 50% duty cycle input clock, 50% duty cycle circuit turned off, time reference delay mode)	35		65	%
$t_{DUTYTRD}$	Output clock duty cycle (at 50% levels, arbitrary duty cycle input clock, 50% duty cycle circuit enabled, time reference delay mode)	40		60	%
$t_{DUTYCIR}$	Output clock duty cycle (at 50% levels, arbitrary duty cycle input clock, 50% duty cycle circuit enabled, clock injection removal mode)	40		60	%
t_{SKEW}^3	Output clock to clock skew between two outputs with the same phase setting	—	—	100	ps
t_{PWH}	Input clock minimum pulse width high (at 80% level)	750	—	—	ps
t_{PWL}	Input clock minimum pulse width low (at 20% level)	750	—	—	ps
t_R, t_F	Input clock rise and fall time (20% to 80% levels)	—	—	1	ns
t_{INSTB}	Input clock period jitter	—	—	+/-250	ps
t_{LOCK}	DLL lock time	18,500	—	—	cycles
t_{RSWD}	Digital reset minimum pulse width (at 80% level)	3	—	—	ns
t_{PA}	Delay step size	16.5	42	59.4	ps
t_{RANGE1}	Max. delay setting for single delay block (144 taps)	2.376	6	8.553	ns
t_{RANGE4}	Max. delay setting for four chained delay blocks	9.504	24	34.214	ns

1. CLKOP runs at the same frequency as the input clock.

2. CLKOS minimum frequency is obtained with divide by 4.

3. This is intended to be a “path-matching” design guideline and is not a measurable specification.

Timing v.A 0.11

SERDES High Speed Data Transmitter (LatticeECP2M Family Only)^{1,2}

Table 3-7. Serial Output Timing and Levels

Symbol	Description	Frequency	Min.	Typ.	Max.	Units
V _{TX-DIFF-P-P-1.25}	Differential swing (1.25V setting) ^{1,2}	0.25 to 3.125 Gbps	—	1.25	—	V, p-p
V _{TX-DIFF-P-P-1.4}	Differential swing (1.4V setting) ^{1,2}	0.25 to 3.125 Gbps	—	1.4	—	V, p-p
V _{TX-DIFF-P-P-1.0}	Differential swing (1.0V setting) ^{1,2}	0.25 to 3.125 Gbps	—	1.0	—	V, p-p
V _{TX-DIFF-P-P-1.2}	Differential swing (1.2V setting) ^{1,2}	0.25 to 3.125 Gbps	—	1.2	—	V, p-p
V _{OCM}	Output common mode voltage	—	—	0.8	—	V
T _{TX-R}	Rise time (20% to 80%)	—	—	70	—	ps
T _{TX-F}	Fall time (80% to 20%)	—	—	70	—	ps
Z _{TX-OI-SE}	Output Impedance 50/75/HiZ K Ohms (single ended)	—	—	50/75 HiZ	—	Ohms
R _{LTX-RL}	Return loss (with package)	—	—	9	—	dB

1. All measurements are with 50 ohm impedance.

2. See technical note TN1124, *LatticeECP2/M SERDES/PCS Usage Guide* for actual binary settings and the min-max range.

Table 3-8. Channel Output Jitter

Description	Frequency	Min.	Typ.	Max.	Units
Deterministic	3.125 Gbps	—	0.08	0.12	UI, p-p
Random	3.125 Gbps	—	0.22	0.38	UI, p-p
Total	3.125 Gbps	—	0.33	0.43	UI, p-p
Deterministic	2.5Gbps	—	0.05	0.11	UI, p-p
Random	2.5Gbps	—	0.17	0.30	UI, p-p
Total	2.5Gbps	—	0.24	0.39	UI, p-p
Deterministic	1.25 Gbps	—	0.03	0.11	UI, p-p
Random	1.25 Gbps	—	0.10	0.18	UI, p-p
Total	1.25 Gbps	—	0.15	0.29	UI, p-p
Deterministic	250 Mbps	—	0.04	0.17	UI, p-p
Random	250 Mbps	—	0.12	0.13	UI, p-p
Total	250 Mbps	—	0.15	0.29	UI, p-p

Note: Values are measured with PRBS 2⁷-1, all channels operating, FPGA Logic active, I/Os around SERDES pins quiet, reference clock @ 10X mode.

Table 3-9. SERDES/PCS Latency Breakdown (Parallel Clock Cycle)

Item	Description	Min.	Average	Max.	Bypass
Transmit Data Latency					
T1	FPGA Bridge Transmit ²	1	3	5	1
T2	8b10b Encoder	2	2	2	1
T3	SERDES Bridge Transmit	2	2	2	1
T4	Serializer ³			2.4	
Receive Data Latency					
R1	Deserializer ³			1.2	
R2	SERDES Bridge Receive	2	2	2	1
R3	Word Alignment	4	4	4	0
R4	8b10b Decoder	1	1	1	1
R5	Clock Tolerance Compensation	7	15	23	1
R6	FPGA Bridge Receive ²	1	3	5	1

1. PCS internal Parallel Clock. This clock rate is same as the rxfullclk in table 8-6.
2. FPGA Bridge latency varies by UP/DOWN Sample FIFO read/write. These numbers were presented for 8bit/10bit interface. The depth of Down Sample/Up Sample FIFO is 4. The earliest read can be done after write clock cycle (1 clock) in Down Sample FIFO. The latest read will be done after the FIFO is full (4 + 1 = 5). For 16b/20b interface, the numbers become doubled. Min = 2, Max = 10. This latency depends on the internal FIFO flag operation.
3. The maximum latency applies to bit0.
 Bit1 latency = Bit0 latency + 1 UI.
 Bit2 latency = Bit0 latency + 2 UI.

Figure 3-12. Transmitter and Receiver Block Diagram

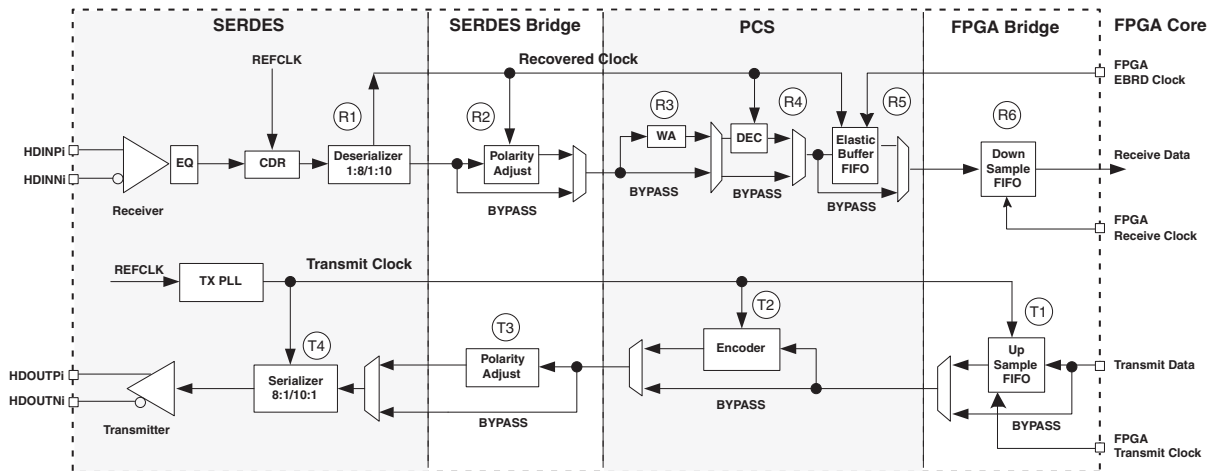

SERDES High Speed Data Receiver (LatticeECP2M Family Only)

Table 3-10. Serial Input Data Specifications

Symbol	Description	Min.	Typ.	Max.	Units
RX-CID _S	Stream of nontransitions ¹ (CID = Consecutive Identical Digits) @ 10 ⁻¹² BER		7 @ 3.125 Gbps 20 @ 1.25 Gbps		Bits
V _{RX-DIFF-S}	Differential input sensitivity	100	—	—	mV, p-p
V _{RX-IN}	Input levels	0	—	V _{CCR_X} + 0.8	V
V _{RX-CM-DC}	Input common mode range (DC coupled)	0.5	—	1.2	V
V _{RX-CM-AC}	Input common mode range (AC coupled) ³	0	—	1.5	V
T _{RX-RELOCK}	CDR re-lock time ²	—	—	3000	Bits
Z _{RX-TERM}	Input termination 50/75 Ohm/High Z	—	50		Ohms
RL _{RX-RL}	Return loss (without package)	—	9	—	dB

1. This is the number of bits allowed without a transition on the incoming data stream when using DC coupling.
2. This is the typical number of bit times to re-lock to a new phase or frequency within +/- 300 ppm, assuming 8b10b encoded data.
3. AC coupling is used to interface to LVPECL and LVDS.

Input Data Jitter Tolerance

A receiver's ability to tolerate incoming signal jitter is very dependent on jitter type. High speed serial interface standards have recognized the dependency on jitter type and have recently modified specifications to indicate tolerance levels for different jitter types as they relate to specific protocols (e.g. FC, etc.). Sinusoidal jitter is considered to be a worst case jitter type.

Table 3-11. Receiver Total Jitter Tolerance Specification¹

Description	Frequency	Condition	Min.	Typ.	Max.	Units
Deterministic	3.125 Gbps	600 mV differential eye	—	—	0.54	UI, p-p
Random		600 mV differential eye	—	—	0.26	UI, p-p
Total		600 mV differential eye	—	—	0.80	UI, p-p
Deterministic	2.5 Gbps	600 mV differential eye	—	—	0.61	UI, p-p
Random		600 mV differential eye	—	—	0.22	UI, p-p
Total		600 mV differential eye	—	—	0.81	UI, p-p
Deterministic	1.25 Gbps	600 mV differential eye	—	—	0.53	UI, p-p
Random		600 mV differential eye	—	—	0.22	UI, p-p
Total		600 mV differential eye	—	—	0.80	UI, p-p
Deterministic	250 Mbps ²	600 mV differential eye	—	—	0.42	UI, p-p
Random		600 mV differential eye	—	—	0.10	UI, p-p
Total		600 mV differential eye	—	—	0.60	UI, p-p

1. Values are measured with PRBS 2⁷-1, all channels operating, FPGA Logic active, I/Os around SERDES pins quiet, voltages are nominal, room temperature.
2. Jitter specification is limited by measurement equipment capability.

Table 3-12. Periodic Receiver Jitter Tolerance Specification¹

Description	Frequency	Condition	Min.	Typ.	Max.	Units
Periodic	3.125 Gbps	600 mV differential eye	—	—	0.20	UI, p-p
	2.5 Gbps	600 mV differential eye	—	—	0.22	UI, p-p
	1.25 Gbps	600 mV differential eye	—	—	0.20	UI, p-p
	250 Mbps ²	600 mV differential eye	—	—	0.08	UI, p-p

1. Values are measured with PRBS 2⁷-1, all channels operating.
2. Jitter specification is limited by measurement equipment capability.

SERDES External Reference Clock (LatticeECP2M Family Only)

The external reference clock selection and its interface are a critical part of system applications for this product. Table 3-13 specifies reference clock requirements, over the full range of operating conditions.

Table 3-13. External Reference Clock Specification (refclkp/refclkn)

Symbol	Description	Min.	Typ.	Max.	Units
F _{REF}	Frequency range	25	—	320	MHz
F _{REF-PPM}	Frequency tolerance	-300	—	300	ppm
V _{REF-IN-SE}	Input swing, single-ended clock ¹	100	—	1200	mV, p-p
V _{REF-IN}	Input levels	0	—	V _{CCP} + 0.8	V
V _{REF-CM-DC}	Input common mode range (DC coupled)	0.5	—	1.2	V
V _{REF-CM-AC}	Input common mode range (AC coupled) ²	0	—	1.5	V
D _{REF}	Duty cycle ³	40	—	60	%
T _{REF-R}	Rise time (20% to 80%)		500	1000	ps
T _{REF-F}	Fall time (80% to 20%)		500	1000	ps
Z _{REF-IN-TERM}	Input termination		50/2K		Ohms
C _{REF-IN-CAP}	Input capacitance ⁴	—	—	1.5	pF

1. The signal swing for a single-ended input clock must be as large as the p-p differential swing of a differential input clock to get the same gain at the input receiver. Lower swings for the clock may be possible, but will tend to increase jitter.
2. When AC coupled, the input common mode range is determined by:
(Min input level) + (Peak-to-peak input swing)/2 ≤ (Input common mode voltage) ≤ (Max input level) - (Peak-to-peak input swing)/2
3. Measured at 50% amplitude.
4. Input capacitance of 1.5pF is total capacitance, including both device and package.

Figure 3-13. Jitter Transfer

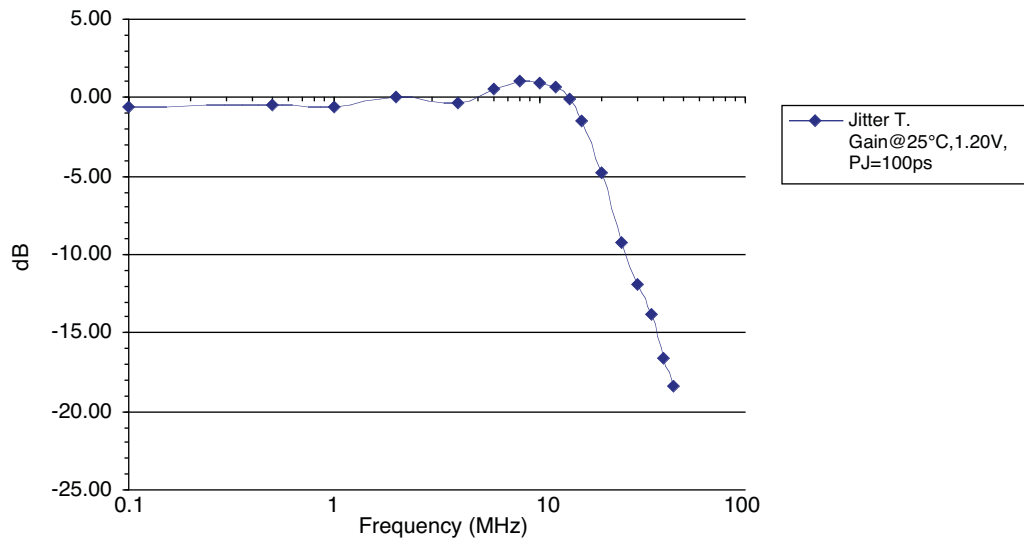

Note: This graph is for a nominal device.

SERDES Power-Down/Power-Up Specification

Table 3-14. Power-Down and Power-Up Specification

Symbol	Description	Max.	Units
t _{PWRDN}	Power-down time after all power down register bits set to '0'	10	s
t _{PWRUP}	Power-up time after all power down register bits set to '1'	5	ms

PCI Express Electrical and Timing Characteristics

AC and DC Characteristics

Table 3-15. Transmit^{1, 2}

Symbol	Description	Test Conditions	Min	Typ	Max	Units
UI	Unit interval		399.88	400	400.12	ps
V _{TX-DIFF_P-P}	Differential peak-to-peak output voltage		0.8	1.0	1.2	V
V _{TX-DE-RATIO}	De-emphasis differential output voltage ratio		0	-3.5	-7.96	dB
V _{TX-CM-AC_P}	RMS AC peak common-mode output voltage		—	20	—	mV
V _{TX-CM-DC-LINE-DELTA}	Maximum Common mode voltage delta between n and p channels		—	—	25	mV
V _{TX-DC-CM}	Tx DC common mode voltage		0	—	V _{CCOB} +5%	V
I _{TX-SHORT}	Output short circuit current	V _{TX-D+} =0.0V V _{TX-D-} =0.0V	—	—	90	mA
Z _{TX-DIFF-DC}	Differential output impedance		80	100	120	Ohms
T _{TX-RISE}	Tx output rise time	20 to 80%	0.125	—	—	UI
T _{TX-FALL}	Tx output fall time	20 to 80%	0.125	—	—	UI
L _{TX-SKEW}	Lane-to-lane static output skew for all lanes in port/link		—	—	1.3	ns
T _{TX-EYE}	Transmitter eye width		0.75	—	—	UI
T _{TX-EYE-MEDIAN-TO-MAX-JITTER} ³			—	—	0.125	UI
C _{TX}	AC coupling capacitor		75	—	200	nF

1. Values are measured at 2.5 Gbps.

2. Compliant to PCI Express v1.1.

3. Measured at 60ps with plug-in board and jitter due to socket removed.

Table 3-16. Receive

Symbol	Description	Test Conditions	Min.	Typ.	Max.	Units
UI	Unit Interval		399.88	400	400.12	ps
V _{RX-DIFF_P-P}	Differential peak-to-peak input voltage		0.175	—	—	V
V _{RX-IDLE-DET-DIFF_P-P}	Idle detect threshold voltage		65	—	175	mV
Z _{RX-DIFF-DC}	DC differential input impedance		80	100	120	Ohms
Z _{RX-DC}	DC input impedance		40	50	60	Ohms
Z _{RX-HIGH-IMP-DC} ¹	Power-down DC input impedance		200K	—	—	Ohms
T _{RX-EYE}	Receiver eye width		0.4	—	—	UI
T _{RX-EYE-MEDIAN-TO-MAX-JITTER}			—	—	0.3	UI

Notes:

1. Measured with external AC-coupling on the receiver

2. Values are measured at 2.5 Gbps

Table 3-17. Reference Clock

Symbol	Description	Test Conditions	Min.	Typ.	Max.	Units
F_{REFCLK}	Reference clock frequency		—	100	—	MHz
V_{CM}	Input common mode voltage		—	0.65	—	V
T_R/T_F	Clock input rise/fall time		—	—	1.0	ns
V_{SW}	Differential input voltage swing		0.6	—	1.6	V
DC_{REFCLK}	Input clock duty cycle		40	50	60	%
PPM	Reference clock tolerance		-300	—	+300	ppm

LatticeECP2/M sysCONFIG Port Timing Specifications

Over Recommended Operating Conditions

Parameter	Description	Min.	Max.	Units
sysCONFIG Byte Data Flow				
t_{SUCBDI}	Byte D[0:7] Setup Time to CCLK	7	—	ns
t_{HCBDI}	Byte D[0:7] Hold Time to CCLK	1	—	ns
t_{CODO}	CCLK to DOUT in Flowthrough Mode	—	12	ns
t_{SUCS}	CSN[0:1] Setup Time to CCLK	7	—	ns
t_{HCS}	CSN[0:1] Hold Time to CCLK	1	—	ns
t_{SUWD}	Write Signal Setup Time to CCLK	7	—	ns
t_{HWD}	Write Signal Hold Time to CCLK	1	—	ns
t_{DCB}	CCLK to BUSY Delay Time	—	12	ns
t_{CORD}	CCLK to Out for Read Data	—	12	ns
sysCONFIG Byte Slave Clocking				
t_{BSCH}	Byte Slave CCLK Minimum High Pulse	6	—	ns
t_{BSCL}	Byte Slave CCLK Minimum Low Pulse	9	—	ns
t_{BSCYC}	Byte Slave CCLK Cycle Time	15	—	ns
sysCONFIG Serial (Bit) Data Flow				
t_{SUSCDI}	DI Setup Time to CCLK Slave Mode	7	—	ns
t_{HSCDI}	DI Hold Time to CCLK Slave Mode	1	—	ns
t_{CODO}	CCLK to DOUT in Flowthrough Mode	—	12	ns
sysCONFIG Serial Slave Clocking				
t_{SSCH}	Serial Slave CCLK Minimum High Pulse	6	—	ns
t_{SSCL}	Serial Slave CCLK Minimum Low Pulse	6	—	ns
sysCONFIG POR, Initialization and Wake-up				
t_{ICFG}	Minimum Vcc to INITN High	—	28	ms
t_{VMC}	Time from t_{ICFG} to Valid Master CCLK	—	2	us
t_{PRGMRJ}	PROGRAMN Pin Pulse Rejection	—	8	ns
t_{PRGM}	PROGRAMN Low Time to Start Configuration	25	—	ns
t_{DINIT}	PROGRAMN High to INITN High Delay	—	1	ms
$t_{DPPINIT}$	Delay Time from PROGRAMN Low to INITN Low	—	37	ns
$t_{DPPDONE}$	Delay Time from PROGRAMN Low to DONE Low	—	37	ns
t_{IODISS}	User I/O Disable from PROGRAMN Low	—	35	ns
t_{IOENSS}	User I/O Enabled Time from CCLK Edge During Wake-up Sequence	—	25	ns
t_{MWC}	Additional Wake Master Clock Signals after DONE Pin High	120	—	cycles
sysCONFIG SPI Port				
t_{CFGX}	INITN High to CCLK Low	—	1	μs
t_{CSSPI}	INITN High to CSSPIN Low	—	2	us
t_{CSCCLK}	CCLK Low before CSSPIN Low	0	—	ns
t_{SOCDO}	CCLK Low to Output Valid	—	15	ns
t_{SOE}	CSSPIN[0:1] Active Setup Time	300	—	ns
t_{CSPID}	CSSPIN[0:1] Low to First CCLK Edge Setup Time	300+3cyc	600+6cyc	ns
f_{MAXSPI}	Max. CCLK Frequency - SPI Flash Read Opcode (0x03) (SPIFASTN = 1)	—	20	MHz
	Max. CCLK Frequency - SPI Flash Fast Read Opcode (0x0B) (SPIFASTN = 0)	—	50	MHz

LatticeECP2/M sysCONFIG Port Timing Specifications (Continued)

Over Recommended Operating Conditions

Parameter	Description	Min.	Max.	Units
t_{SUSPI}	SOSPI Data Setup Time Before CCLK	7	—	ns
t_{HSPI}	SOSPI Data Hold Time After CCLK	2	—	ns

Timing v.A 0.11

Parameter	Min.	Max.	Units
Master Clock Frequency	Selected value - 30%	Selected value + 30%	MHz
Duty Cycle	40	60	%

Timing v.A 0.11

Figure 3-14. sysCONFIG Parallel Port Read Cycle

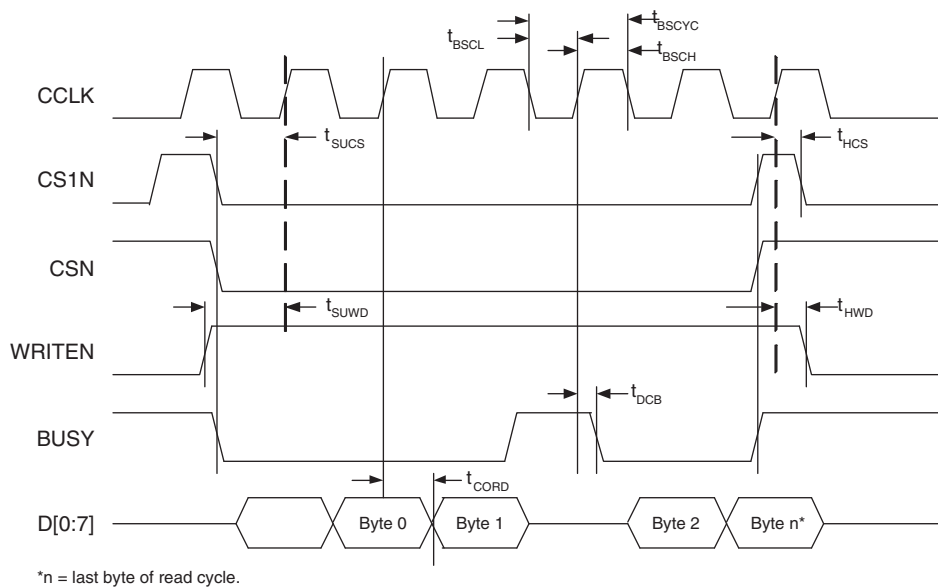

Figure 3-15. sysCONFIG Parallel Port Write Cycle

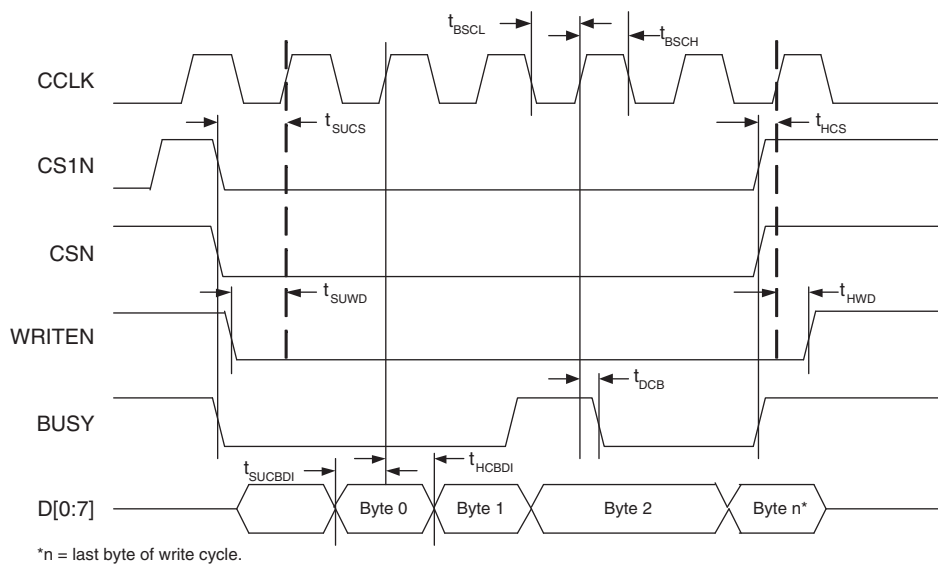

Figure 3-16. sysCONFIG Slave Serial Port Timing

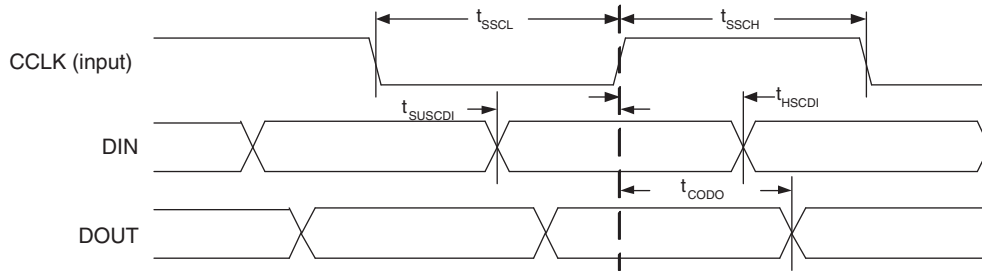
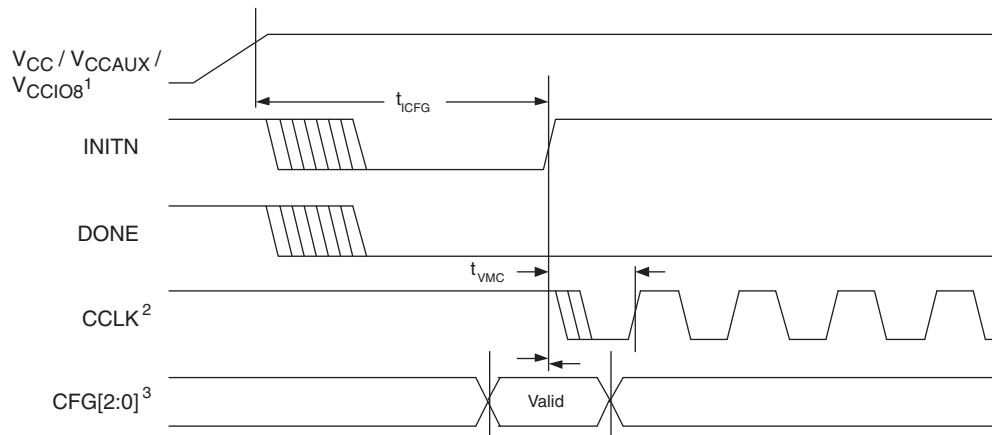
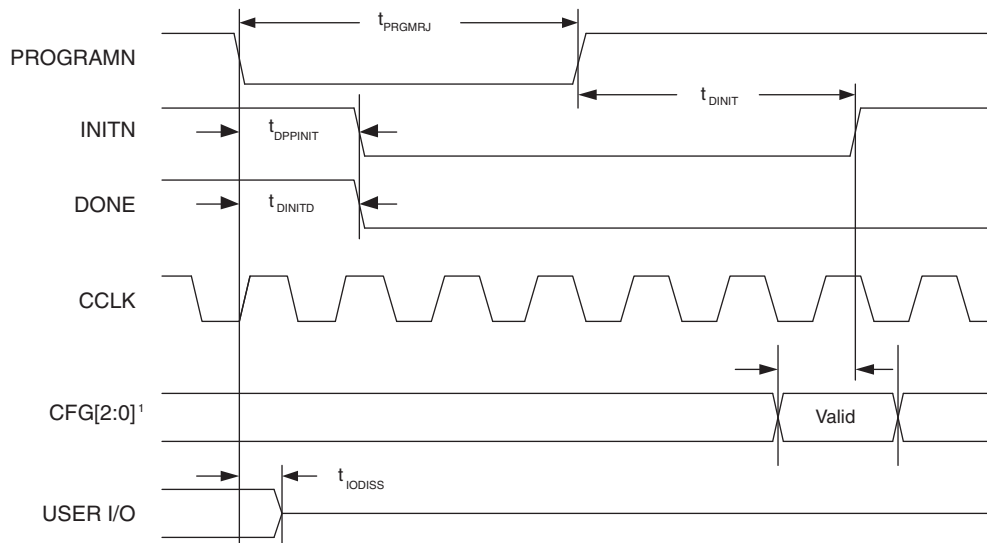

Figure 3-17. Power-On-Reset (POR) Timing



1. Time taken from VCC, VCCAUX or VCCIO8, whichever is the last to cross the POR trip point.
2. Device is in a Master Mode (SPI, SPI_m).
3. The CFG pins are normally static (hard wired).

Figure 3-18. Configuration from PROGRAMN Timing



1. The CFG pins are normally static (hard wired)

Figure 3-19. Wake-Up Timing

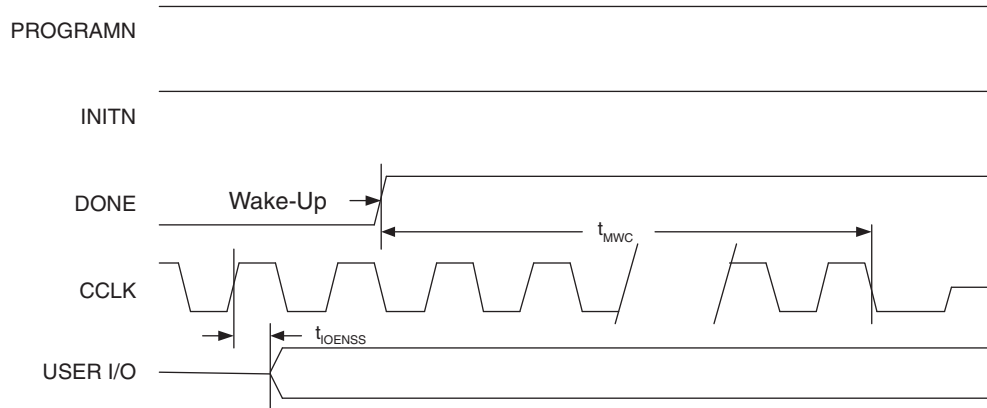
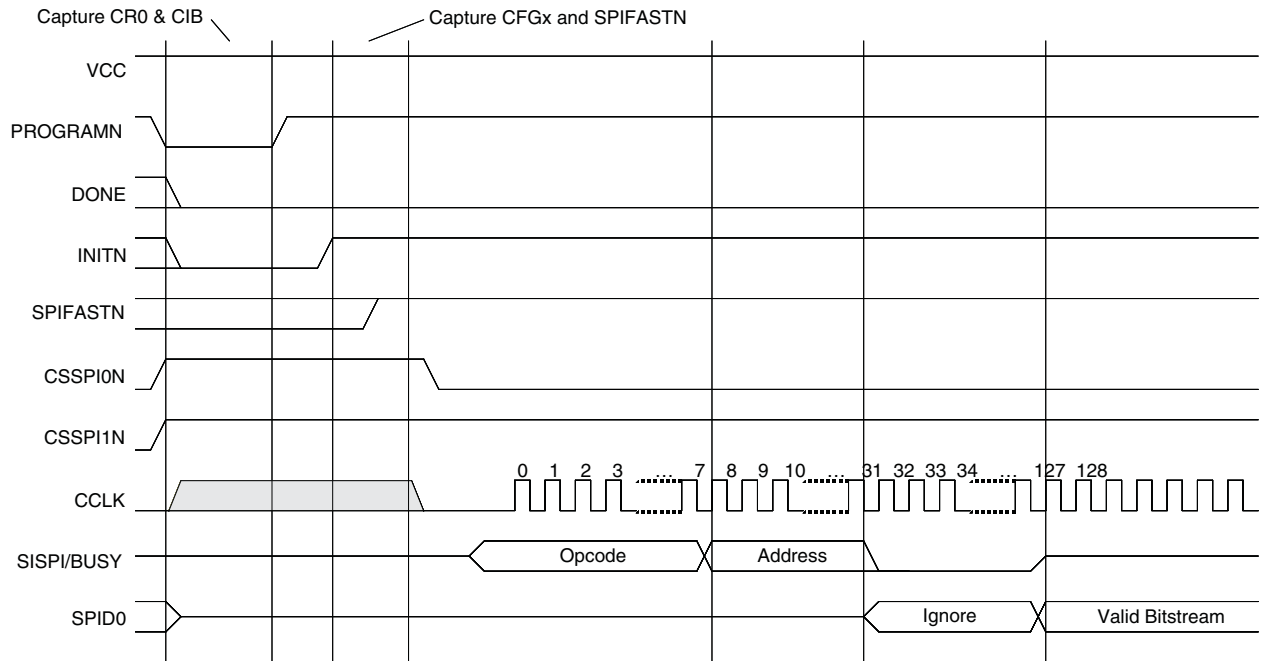

Figure 3-20. SPI/SPI_m Configuration Waveforms



JTAG Port Timing Specifications

Over Recommended Operating Conditions

Symbol	Parameter	Min	Max	Units
f_{MAX}	TCK clock frequency	—	25	MHz
t_{BTCP}	TCK [BSCAN] clock pulse width	40	—	ns
t_{BTCPH}	TCK [BSCAN] clock pulse width high	20	—	ns
t_{BTCPL}	TCK [BSCAN] clock pulse width low	20	—	ns
t_{BTS}	TCK [BSCAN] setup time	8	—	ns
t_{BTH}	TCK [BSCAN] hold time	10	—	ns
t_{BTRF}	TCK [BSCAN] rise/fall time	50	—	mV/ns
t_{BTCO}	TAP controller falling edge of clock to valid output	—	10	ns
$t_{BTCODIS}$	TAP controller falling edge of clock to valid disable	—	10	ns
t_{BTCOEN}	TAP controller falling edge of clock to valid enable	—	10	ns
t_{BTCRS}	BSCAN test capture register setup time	8	—	ns
t_{BTCRH}	BSCAN test capture register hold time	25	—	ns
t_{BUTCO}	BSCAN test update register, falling edge of clock to valid output	—	25	ns
$t_{BTUODIS}$	BSCAN test update register, falling edge of clock to valid disable	—	25	ns
$t_{BTUPOEN}$	BSCAN test update register, falling edge of clock to valid enable	—	25	ns

Timing v.A 0.11

Figure 3-21. JTAG Port Timing Waveforms

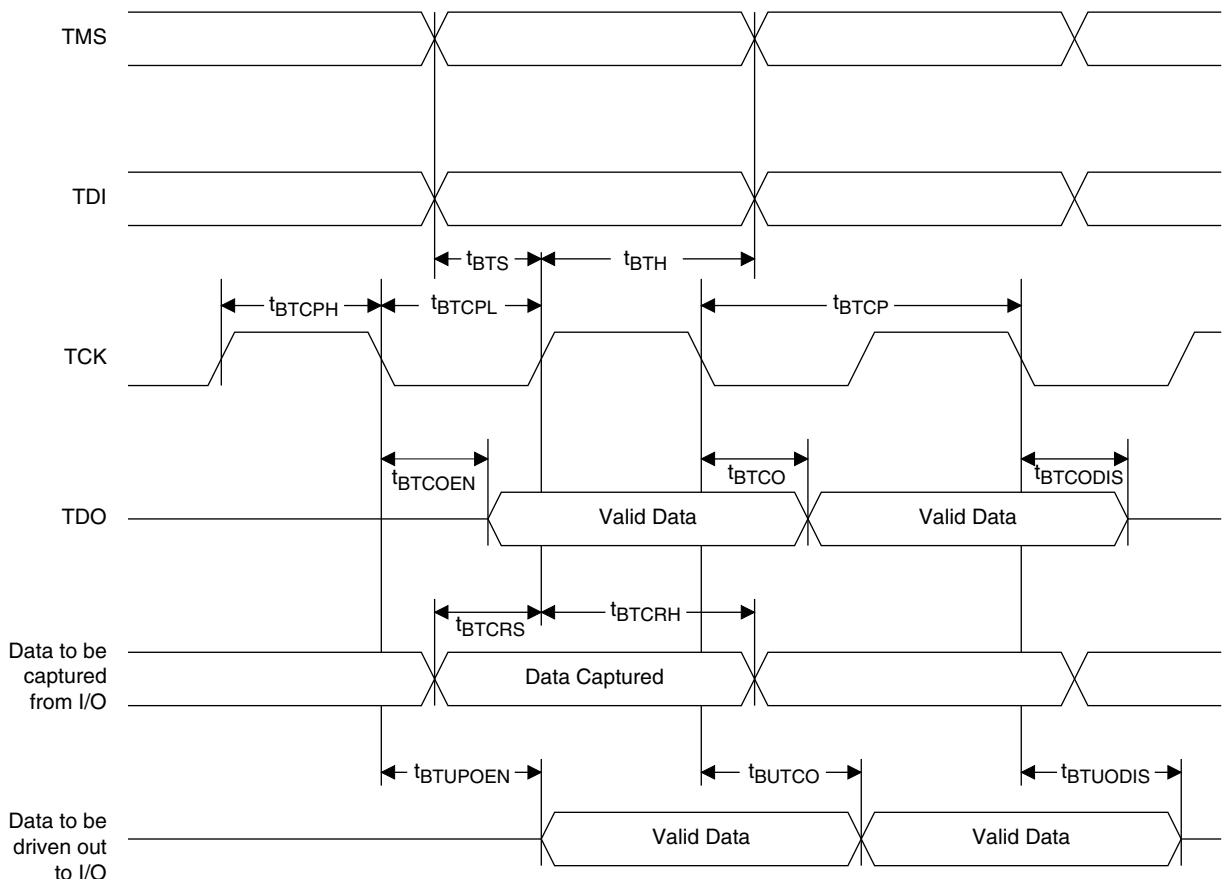

Switching Test Conditions

Figure 3-23 shows the output test load that is used for AC testing. The specific values for resistance, capacitance, voltage, and other test conditions are shown in Table 3-18.

Figure 3-22. Output Test Load, LVTTTL and LVCMOS Standards

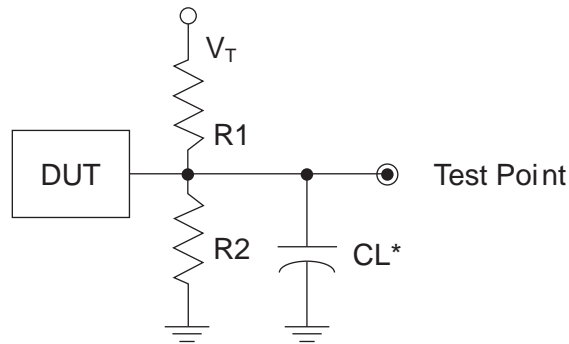

*CL Includes Test Fixture and Probe Capacitance

Table 3-18. Test Fixture Required Components, Non-Terminated Interfaces

Test Condition	R ₁	R ₂	C _L	Timing Ref.	V _T
LVTTTL and other LVCMOS settings (L -> H, H -> L)	∞	∞	0pF	LVCMOS 3.3 = 1.5V	—
				LVCMOS 2.5 = V _{CCIO} /2	—
				LVCMOS 1.8 = V _{CCIO} /2	—
				LVCMOS 1.5 = V _{CCIO} /2	—
				LVCMOS 1.2 = V _{CCIO} /2	—
LVCMOS 2.5 I/O (Z -> H)	∞	1MΩ		V _{CCIO} /2	—
LVCMOS 2.5 I/O (Z -> L)	1MΩ	∞		V _{CCIO} /2	V _{CCIO}
LVCMOS 2.5 I/O (H -> Z)	∞	100		V _{OH} - 0.10	—
LVCMOS 2.5 I/O (L -> Z)	100	∞		V _{OL} + 0.10	V _{CCIO}

Note: Output test conditions for all other interfaces are determined by the respective standards.

Signal Descriptions

Signal Name	I/O	Description
General Purpose		
P[Edge] [Row/Column Number*]_[A/B]	I/O	<p>[Edge] indicates the edge of the device on which the pad is located. Valid edge designations are L (Left), B (Bottom), R (Right), T (Top).</p> <p>[Row/Column Number] indicates the PFU row or the column of the device on which the PIC exists. When Edge is T (Top) or B (Bottom), only need to specify Row Number. When Edge is L (Left) or R (Right), only need to specify Column Number.</p> <p>[A/B] indicates the PIO within the PIC to which the pad is connected. Some of these user-programmable pins are shared with special function pins. These pins, when not used as special purpose pins, can be programmed as I/Os for user logic. During configuration the user-programmable I/Os are tri-stated with an internal pull-up resistor enabled. If any pin is not used (or not bonded to a package pin), it is also tri-stated with an internal pull-up resistor enabled after configuration.</p>
GSRN	I	Global RESET signal (active low). Any I/O pin can be GSRN.
NC	—	No connect.
GND	—	Ground. Dedicated pins.
V _{CC}	—	Power supply pins for core logic. Dedicated pins.
V _{CCAUX}	—	Auxiliary power supply pin. This dedicated pin powers all the differential and referenced input buffers.
V _{CCIOx}	—	Dedicated power supply pins for I/O bank x.
V _{CCPLL}	—	PLL supply pins. Should be tied to V _{CC} even when the corresponding PLL is unused.
V _{REF1_x} , V _{REF2_x}	—	Reference supply pins for I/O bank x. Pre-determined pins in each bank are assigned as V _{REF} inputs. When not used, they may be used as I/O pins.
XRES ⁴	—	10K ohm +/-1% resistor must be connected between this pad and ground.
PLLCAP ⁴	—	External capacitor connection for PLL.
PLL, DLL and Clock Functions (Used as user programmable I/O pins when not in use for PLL or clock pins)		
[LOC][num]_V _{CCPLL}	—	Power supply pin for PLL: ULM, LLM, URM, LRM, num = row from center.
[LOC][num]_GPLL[T, C]_IN_A	I	General Purpose PLL (GPLL) input pads: ULM, LLM, URM, LRM, num = row from center, T = true and C = complement, index A,B,C...at each side.
[LOC][num]_GPLL[T, C]_FB_A	I	Optional feedback GPLL input pads: ULM, LLM, URM, LRM, num = row from center, T = true and C = complement, index A,B,C...at each side.
[LOC][num]_SPLL[T, C]_IN_A	I	Secondary PLL (SPLL) input pads: ULM, LLM, URM, LRM, num = row from center, T = true and C = complement, index A,B,C...at each side.
[LOC][num]_SPLL[T, C]_FB_A	I	Optional feedback (SPLL) input pads: ULM, LLM, URM, LRM, num = row from center, T = true and C = complement, index A,B,C...at each side.
[LOC][num]_DLL[T, C]_IN_A	I	DLL input pads: ULM, LLM, URM, LRM, num = row from center, T = true and C = complement, index A,B,C...at each side.
[LOC][num]_DLL[T, C]_FB_A	I	Optional feedback (DLL) input pads: ULM, LLM, URM, LRM, num = row from center, T = true and C = complement, index A,B,C...at each side.
PCLK[T, C]_[n:0]_[3:0]	I	Primary Clock pads, T = true and C = complement, n per side, indexed by bank and 0,1,2,3 within bank.

© 2008 Lattice Semiconductor Corp. All Lattice trademarks, registered trademarks, patents, and disclaimers are as listed at www.latticesemi.com/legal. All other brand or product names are trademarks or registered trademarks of their respective holders. The specifications and information herein are subject to change without notice.

Signal Descriptions (Cont.)

Signal Name	I/O	Description
[LOC]DQS[num]	I/O	DQ input/output pads: T (top), R (right), B (bottom), L (left), DQS, num = ball function number.
[LOC]DQ[num]	I/O	DQ input/output pads: T (top), R (right), B (bottom), L (left), DQ, associated DQS number.
Test and Programming (Dedicated Pins)		
TMS	I	Test Mode Select input, used to control the 1149.1 state machine. Pull-up is enabled during configuration.
TCK	I	Test Clock input pin, used to clock the 1149.1 state machine. No pull-up enabled.
TDI	I	Test Data in pin. Used to load data into device using 1149.1 state machine. After power-up, this TAP port can be activated for configuration by sending appropriate command. (Note: once a configuration port is selected it is locked. Another configuration port cannot be selected until the power-up sequence). Pull-up is enabled during configuration.
TDO	O	Output pin. Test Data Out pin used to shift data out of a device using 1149.1.
VCCJ	—	Power supply pin for JTAG Test Access Port.
Configuration Pads (Used During sysCONFIG)		
CFG[2:0]	I	Mode pins used to specify configuration mode values latched on rising edge of INITN. During configuration, a pull-up is enabled. These are dedicated pins.
INITN	I/O	Open Drain pin. Indicates the FPGA is ready to be configured. During configuration, a pull-up is enabled. It is a dedicated pin.
PROGRAMN	I	Initiates configuration sequence when asserted low. This pin always has an active pull-up. This is a dedicated pin.
DONE	I/O	Open Drain pin. Indicates that the configuration sequence is complete, and the startup sequence is in progress. This is a dedicated pin.
CCLK	I/O	Configuration Clock for configuring an FPGA in sysCONFIG mode.
BUSY/SISPI	I/O	Read control command in SPI or SPIm mode.
CSN	I	sysCONFIG chip select (active low). During configuration, a pull-up is enabled.
CS1N	I	sysCONFIG chip select (active low). During configuration, a pull-up is enabled.
WRITEN	I	Write Data on Parallel port (active low).
D[0]/SPIFASTN	I/O	sysCONFIG Port Data I/O for Parallel mode. sysCONFIG Port Data I/O for SPI or SPIm. When using the SPI or SPIm mode, this pin should either be tied high or low, must not be left floating.
D[1:6]	I/O	sysCONFIG Port Data I/O for Parallel
D[7]/SPID0	I/O	sysCONFIG Port Data I/O for Parallel, SPI, SPIm
DOUT/CSN	O	Output for serial configuration data (rising edge of CCLK) when using sysCONFIG port.
DI/CSSPI0N	I/O	Input for serial configuration data (clocked with CCLK) when using sysCONFIG port. During configuration, a pull-up is enabled. Output when used in SPI/SPIm modes.
Dedicated SERDES Signals^{1,2,3}		
[LOC]_SQ_VCCAUX33	—	Termination resistor switching power (3.3V). This pin must be tied to 3.3V even if the quad is unused.
[LOC]_SQ_REFCLKN	I	Negative Reference Clock Input
[LOC]_SQ_REFCLKP	I	Positive Reference Clock Input
[LOC]_SQ_VCCP	—	PLL and Reference clock buffer power (1.2V). This pin must be tied to 1.2V even if the quad is unused.

Signal Descriptions (Cont.)

Signal Name	I/O	Description
[LOC]_SQ_VCCIBm	—	Input buffer power supply, channel m (1.2V/1.5V). This pin should be left floating if the channel is unused.
[LOC]_SQ_VCCOBm	—	Output buffer power supply, channel m (1.2V/1.5V). This pin should be left floating if the channel is unused.
[LOC]_SQ_HDOUINm	O	High-speed output, negative channel m
[LOC]_SQ_HDOUOPm	O	High-speed output, positive channel m
[LOC]_SQ_HDINNm	I	High-speed input, negative channel m
[LOC]_SQ_HDINPm	I	High-speed input, positive channel m
[LOC]_SQ_VCCTXm ⁴	—	Transmitter power supply, channel m (1.2V). This pin must be tied to 1.2V even if the channel is unused.
[LOC]_SQ_VCCR Xm ⁴	—	Receiver power supply, channel m (1.2V). This pin must be tied to 1.2V even if the channel is unused.

1. These signals are relevant for LatticeECP2M family.
2. m defines the associated channel in the Quad.
3. These signals are defined in Quads [LOC] indicates the corner SERDES Quad is located: ULC (upper left), URC (upper right), LLC (lower left), LRC (lower right).
4. When placing switching I/Os around these critical pins that are designed to supply the device with the proper reference or supply voltage, care must be given. For more information, refer to technical note TN1159, *LatticeECP2/M Pin Assignment Recommendations*.

PICs and DDR Data (DQ) Pins Associated with the DDR Strobe (DQS) Pin

PICs Associated with DQS Strobe	PIO Within PIC	DDR Strobe (DQS) and Data (DQ) Pins
For Left and Right Edges of the Device		
P[Edge] [n-4]	A	DQ
	B	DQ
P[Edge] [n-3]	A	DQ
	B	DQ
P[Edge] [n-2]	A	DQ
	B	DQ
P[Edge] [n-1]	A	DQ
	B	DQ
P[Edge] [n]	A	[Edge]DQSn
	B	DQ
P[Edge] [n+1]	A	DQ
	B	DQ
P[Edge] [n+2]	A	DQ
	B	DQ
P[Edge] [n+3]	A	DQ
	B	DQ
For Bottom Edge of the Device		
P[Edge] [n-4]	A	DQ
	B	DQ
P[Edge] [n-3]	A	DQ
	B	DQ
P[Edge] [n-2]	A	DQ
	B	DQ
P[Edge] [n-1]	A	DQ
	B	DQ
P[Edge] [n]	A	[Edge]DQSn
	B	DQ
P[Edge] [n+1]	A	DQ
	B	DQ
P[Edge] [n+2]	A	DQ
	B	DQ
P[Edge] [n+3]	A	DQ
	B	DQ
P[Edge] [n+4]	A	DQ
	B	DQ

Notes:

1. "n" is a row PIC number.
2. The DDR interface is designed for memories that support one DQS strobe up to 15 bits of data for the left and right edges and up to 17 bits of data for the bottom edge. In some packages, all the potential DDR data (DQ) pins may not be available. PIC numbering definitions are provided in the "Signal Names" column of the Signal Descriptions table.

LatticeECP2 Pin Information Summary, LFE2-6 and LFE2-12

Pin Type		LFE2-6		LFE2-12			
		144 TQFP	256 fpBGA	144 TQFP	208 PQFP	256 fpBGA	484 fpBGA
Single Ended User I/O		90	190	93	131	193	297
Differential Pair User I/O		43	95	45	62	96	148
Configuration	TAP Pins	5	5	5	5	5	5
	Muxed Pins	14	14	14	14	14	14
	Dedicated Pins (Non TAP)	7	7	7	7	7	7
Non Configuration	Muxed Pins	34	54	33	40	54	57
	Dedicated Pins	3	3	3	3	3	3
VCC		10	7	10	14	7	16
VCCAUX		4	4	4	8	4	16
VCCPLL		0	0	0	0	0	0
VCCIO	Bank0	1	2	1	2	2	4
	Bank1	1	2	1	2	2	4
	Bank2	1	2	1	2	2	4
	Bank3	1	2	1	2	2	4
	Bank4	1	2	1	2	2	4
	Bank5	1	2	1	2	2	4
	Bank6	1	2	1	2	2	4
	Bank7	1	2	1	2	2	4
	Bank8	1	1	1	2	1	2
GND, GND0 to GND7		12	20	12	22	20	60
NC		4	3	1	0	0	44
Single Ended/ Differential I/O Pairs per Bank (including emulated with resistors)	Bank0	8/4	18/6	8/4	18/9	18/9	50/25
	Bank1	17/8	34/17	18/9	18/9	34/17	46/23
	Bank2	4/2	20/10	4/2	11/5	20/10	24/12
	Bank3	8/4	12/6	8/4	11/5	12/6	16/8
	Bank4	18/9	32/16	18/9	19/9	32/16	46/23
	Bank5	8/4	14/7	10/5	18/9	17/8	46/23
	Bank6	9/4	26/13	9/4	18/8	26/13	32/16
	Bank7	12/6	20/10	12/6	12/6	20/10	23/11
	Bank8	6/2	14/7	6/2	6/2	14/7	14/7
True LVDS I/O Pairs per Bank	Bank0 (Top Edge)	0	0	0	0	0	0
	Bank1 (Top Edge)	0	0	0	0	0	0
	Bank2 (Right Edge)	1	5	1	4	5	6
	Bank3 (Right Edge)	3	3	3	3	3	4
	Bank4 (Bottom Edge)	0	0	0	0	0	0
	Bank5 (Bottom Edge)	0	0	0	0	0	0
	Bank6 (Left Edge)	2	7	2	6	7	8
	Bank7 (Left Edge)	5	5	5	5	5	5
	Bank8 (Right Edge)	0	0	0	0	0	0

LatticeECP2 Pin Information Summary, LFE2-6 and LFE2-12 (Cont.)

Pin Type		LFE2-6		LFE2-12			
		144 TQFP	256 fpBGA	144 TQFP	208 PQFP	256 fpBGA	484 fpBGA
Available DDR-Interfaces per I/O Bank ¹	Bank0	0	0	0	0	0	0
	Bank1	0	0	0	0	0	0
	Bank2	0	1	0	0	1	1
	Bank3	0	0	0	0	0	0
	Bank4	0	2	0	0	2	3
	Bank5	0	1	0	0	1	3
	Bank6	0	1	0	0	1	1
	Bank7	0	1	0	0	1	1
	Bank8	0	0	0	0	0	0
PCI Capable I/Os per Bank	Bank0	0	0	0	0	0	0
	Bank1	0	0	0	0	0	0
	Bank2	0	0	0	0	0	0
	Bank3	0	0	0	0	0	0
	Bank4	18	32	18	19	32	46
	Bank5	8	14	10	18	17	46
	Bank6	0	0	0	0	0	0
	Bank7	0	0	0	0	0	0
	Bank8	0	0	0	0	0	0

1. Minimum requirement to implement a fully functional 8-bit wide DDR bus. Available DDR interface consists of at least 12 I/Os (1 DQS + 1 DQSB + 8 DQs + 1 DM + Bank VREF1).

LatticeECP2 Pin Information Summary, LFE2-20 and LFE2-35

Pin Type		LFE2-20				LFE2-35	
		208 PQFP	256 fpBGA	484 fpBGA	672 fpBGA	484 fpBGA	672 fpBGA
Single Ended User I/O		131	193	331	402	331	450
Differential Pair User I/O		62	96	165	200	165	224
Configuration	TAP Pins	5	5	5	5	5	5
	Muxed Pins	14	14	14	14	14	14
	Dedicated Pins (Non TAP)	7	7	7	7	7	7
Non Configuration	Muxed Pins	42	54	60	64	60	68
	Dedicated Pins	3	3	3	3	3	3
VCC		14	7	18	24	16	22
VCCAUX		8	4	16	16	16	16
VCCPLL		0	0	0	0	2	2
VCCIO	Bank0	2	2	4	5	4	5
	Bank1	2	2	4	5	4	5
	Bank2	2	2	4	5	4	5
	Bank3	2	2	4	5	4	5
	Bank4	2	2	4	5	4	5
	Bank5	2	2	4	5	4	5
	Bank6	2	2	4	5	4	5
	Bank7	2	2	4	5	4	5
	Bank8	2	1	2	2	2	2
GND, GND0 to GND7		22	20	60	72	60	72
NC		0	1	8	101	8	102
Single Ended/ Differential I/O Pairs per Bank (including emulated with resistors)	Bank0	18/9	18/9	50/25	67/33	50/25	67/33
	Bank1	18/9	34/17	46/23	52/26	46/23	52/26
	Bank2	11/5	20/10	34/17	36/18	34/17	48/24
	Bank3	11/5	12/6	22/11	32/16	22/11	42/21
	Bank4	19/9	32/16	46/23	50/25	46/23	54/27
	Bank5	18/9	17/8	46/23	68/34	46/23	68/34
	Bank6	18/8	26/13	40/20	48/24	40/20	58/29
	Bank7	12/6	20/10	33/16	35/17	33/16	47/23
	Bank8	6/2	14/7	14/7	14/7	14/7	14/7
True LVDS I/O Pairs per Bank	Bank0 (Top Edge)	0	0	0	0	0	0
	Bank1 (Top Edge)	0	0	0	0	0	0
	Bank2 (Right Edge)	4	5	9	9	9	12
	Bank3 (Right Edge)	3	3	5	8	5	9
	Bank4 (Bottom Edge)	0	0	0	0	0	0
	Bank5 (Bottom Edge)	0	0	0	0	0	0
	Bank6 (Left Edge)	6	7	10	12	10	13
	Bank7 (Left Edge)	5	5	8	8	8	11
	Bank8 (Right Edge)	0	0	0	0	0	0

LatticeECP2 Pin Information Summary, LFE2-20 and LFE2-35 (Cont.)

Pin Type		LFE2-20				LFE2-35	
		208 PQFP	256 fpBGA	484 fpBGA	672 fpBGA	484 fpBGA	672 fpBGA
Available DDR-Interfaces per I/O Bank ¹	Bank0	0	0	0	0	0	0
	Bank1	0	0	0	0	0	0
	Bank2	0	1	2	2	2	3
	Bank3	0	0	0	2	0	2
	Bank4	0	2	3	3	3	3
	Bank5	0	1	3	4	3	4
	Bank6	0	1	2	3	1	3
	Bank7	0	1	2	2	2	3
	Bank8	0	0	0	0	0	0
PCI Capable I/Os per Bank	Bank0	0	0	0	0	0	0
	Bank1	0	0	0	0	0	0
	Bank2	0	0	0	0	0	0
	Bank3	0	0	0	0	0	0
	Bank4	19	32	46	50	46	54
	Bank5	18	17	46	68	46	68
	Bank6	0	0	0	0	0	0
	Bank7	0	0	0	0	0	0
	Bank8	0	0	0	0	0	0

1. Minimum requirement to implement a fully functional 8-bit wide DDR bus. Available DDR interface consists of at least 12 I/Os (1 DQS + 1 DQSB + 8 DQs + 1 DM + Bank VREF1).

LatticeECP2 Pin Information Summary, LFE2-50 and LFE2-70

Pin Type		LFE2-50		LFE2-70	
		484 fpBGA	672 fpBGA	672 fpBGA	900 fpBGA
Single Ended User I/O		339	500	500	583
Differential Pair User I/O		169	249	249	290
Configuration	TAP Pins	5	5	5	5
	Muxed Pins	14	14	14	14
	Dedicated Pins (Non TAP)	7	7	7	7
Non Configuration	Muxed Pins	68	79	79	89
	Dedicated Pins	3	3	3	3
VCC		16	20	20	26
VCCAUX		16	16	16	17
VCCPLL		4	4	2	4
VCCIO	Bank0	4	5	5	6
	Bank1	4	5	5	6
	Bank2	4	5	5	6
	Bank3	4	5	5	6
	Bank4	4	5	5	6
	Bank5	4	5	5	6
	Bank6	4	5	5	6
	Bank7	4	5	5	6
	Bank8	2	2	2	2
GND, GND0 to GND7		60	72	72	104
NC		0	3	5	101
Single Ended/ Differential I/O Pairs per Bank (including emulated with resistors)	Bank0	50/25	67/33	67/33	84/42
	Bank1	46/23	66/33	66/33	76/38
	Bank2	38/19	56/28	56/28	74/37
	Bank3	22/11	48/24	48/24	48/24
	Bank4	46/23	62/31	62/31	72/35
	Bank5	46/23	68/34	68/34	80/40
	Bank6	40/20	64/32	64/32	64/32
	Bank7	37/18	55/27	55/27	71/35
	Bank8	14/7	14/7	14/7	14/7
True LVDS I/O Pairs per Bank	Bank0 (Top Edge)	0	0	0	0
	Bank1 (Top Edge)	0	0	0	0
	Bank2 (Right Edge)	9	13	13	18
	Bank3 (Right Edge)	5	12	12	12
	Bank4 (Bottom Edge)	0	0	0	0
	Bank5 (Bottom Edge)	0	0	0	0
	Bank6 (Left Edge)	10	16	16	16
	Bank7 (Left Edge)	8	12	12	16
	Bank8 (Right Edge)	0	0	0	0

LatticeECP2 Pin Information Summary, LFE2-50 and LFE2-70 (Cont.)

Pin Type		LFE2-50		LFE2-70	
		484 fpBGA	672 fpBGA	672 fpBGA	900 fpBGA
Available DDR-Interfaces per I/O Bank ¹	Bank0	0	0	0	0
	Bank1	0	0	0	0
	Bank2	2	3	3	4
	Bank3	0	3	3	3
	Bank4	3	4	4	4
	Bank5	3	4	4	5
	Bank6	1	4	4	4
	Bank7	2	3	3	4
	Bank8	0	0	0	0
PCI Capable I/Os per Bank	Bank0	0	0	0	0
	Bank1	0	0	0	0
	Bank2	0	0	0	0
	Bank3	0	0	0	0
	Bank4	46	62	62	72
	Bank5	46	68	68	80
	Bank6	0	0	0	0
	Bank7	0	0	0	0
	Bank8	0	0	0	0

1. Minimum requirement to implement a fully functional 8-bit wide DDR bus. Available DDR interface consists of at least 12 I/Os (1 DQS + 1 DQSB + 8 DQs + 1 DM + Bank VREF1).

LatticeECP2M Pin Information Summary, LFE2M20 and LFE2M35

Pin Type		LFE2M20		LFE2M35		
		256 fpBGA	484 fpBGA	256 fpBGA	484 fpBGA	672 fpBGA
Single Ended User I/O		140	304	140	303	410
Differential Pair User I/O		70	152	70	151	199
Configuration	TAP Pins	5	5	5	5	5
	Muxed Pins	14	14	14	14	14
	Dedicated Pins (Non TAP)	7	7	7	7	7
Non Configuration	Muxed Pins	64	84	60	84	89
	Dedicated Pins	3	3	3	3	3
VCC		6	16	6	16	29
VCCAUX		4	8	4	8	17
VCCPLL		1	4	1	4	8
VCCIO	Bank0	1	4	1	4	5
	Bank1	1	3	1	3	4
	Bank2	2	4	2	4	5
	Bank3	2	4	2	4	5
	Bank4	2	4	2	4	4
	Bank5	2	4	2	4	5
	Bank6	2	4	2	4	5
	Bank7	2	4	2	4	5
	Bank8	1	2	1	2	2
GND, GND0 to GND7		22	57	22	57	80
NC		17	11	17	12	37
Single Ended/ Differential I/O Pairs per Bank (including emulated with resistors)	Bank0	0/0	36/18	0/0	36/18	63/31
	Bank1	0/0	18/9	0/0	18/9	18/9
	Bank2	14/7	30/15	14/7	30/15	50/25
	Bank3	16/8	36/18	16/8	36/18	43/21
	Bank4	32/16	62/31	32/16	62/31	50/21
	Bank5	20/10	28/14	20/10	28/14	60/30
	Bank6	16/8	40/20	16/8	39/19	52/25
	Bank7	28/14	40/20	28/14	40/20	60/30
	Bank8	14/7	14/7	14/7	14/7	14/7
True LVDS I/O Pairs per Bank	Bank0 (Top Edge)	0	0	0	0	0
	Bank1 (Top Edge)	0	0	0	0	0
	Bank2 (Right Edge)	3	7	3	7	12
	Bank3 (Right Edge)	4	9	4	9	11
	Bank4 (Bottom Edge)	0	0	0	0	0
	Bank5 (Bottom Edge)	0	0	0	0	0
	Bank6 (Left Edge)	4	10	4	10	14
	Bank7 (Left Edge)	7	10	7	10	15
	Bank8 (Right Edge)	0	0	0	0	0

LatticeECP2M Pin Information Summary, LFE2M20 and LFE2M35 (Cont.)

Pin Type		LFE2M20		LFE2M35		
		256 fpBGA	484 fpBGA	256 fpBGA	484 fpBGA	672 fpBGA
Available DDR-Interfaces per I/O Bank ¹	Bank0	0	0	0	0	0
	Bank1	0	0	0	0	0
	Bank2	0	1	0	1	3
	Bank3	0	1	0	1	2
	Bank4	2	4	2	4	3
	Bank5	1	2	1	2	3
	Bank6	0	3	0	1	2
	Bank7	1	2	1	2	3
	Bank8	0	0	0	0	0
PCI Capable I/Os per Bank	Bank0	0	0	0	0	0
	Bank1	0	0	0	0	0
	Bank2	0	0	0	0	0
	Bank3	0	0	0	0	0
	Bank4	32	62	32	62	50
	Bank5	20	28	20	28	60
	Bank6	16	40	16	39	52
	Bank7	28	40	28	40	60
	Bank8	0	0	0	0	0

1. Minimum requirement to implement a fully functional 8-bit wide DDR bus. Available DDR interface consists of at least 12 I/Os (1 DQS + 1 DQSB + 8 DQs + 1 DM + Bank VREF1).

LatticeECP2M Pin Information Summary, LFE2M50, LFE2M70 and LFE2M100

Pin Type		LFE2M50			LFE2M70		LFE2M100	
		484 fpBGA	672 fpBGA	900 fpBGA	900 fpBGA	1152 fpBGA	900 fpBGA	1152 fpBGA
Single Ended User I/O		270	372	410	416	436	416	520
Differential Pair User I/O		135	185	205	208	218	207	260
Configuration	TAP Pins	5	5	5	5	5	5	5
	Muxed Pins	14	14	14	14	14	14	14
	Dedicated Pins (Non TAP)	7	7	7	7	7	7	7
Non Configuration	Muxed Pins	69	72	72	75	76	74	78
	Dedicated Pins	3	3	3	3	3	3	3
VCC		16	20	62	44	44	44	44
VCCAUX		8	26	18	16	12	16	12
VCCPLL		4	8	4	4	4	4	4
VCCIO	Bank0	4	5	6	6	7	6	7
	Bank1	3	4	6	6	7	6	7
	Bank2	4	5	9	9	9	9	9
	Bank3	4	5	9	9	9	9	9
	Bank4	4	4	6	6	7	6	7
	Bank5	4	5	6	6	7	6	7
	Bank6	4	5	9	9	9	9	9
	Bank7	4	5	9	9	9	9	9
	Bank8	2	2	2	2	2	2	2
GND, GND0 to GND7		57	80	122	122	134	122	134
NC		31	35	121	63	283	63	199
Single Ended/ Differential I/O Pairs per Bank (including emulated with resistors)	Bank0	36/18	63/31	56/28	34/17	46/23	34/17	54/27
	Bank1	18/9	18/9	36/18	42/21	34/17	42/21	44/22
	Bank2	30/15	50/25	54/27	70/35	72/36	70/35	80/40
	Bank3	36/18	43/21	44/22	60/30	64/32	60/30	80/40
	Bank4	42/21	24/12	38/19	38/19	40/20	38/19	44/22
	Bank5	28/14	60/30	58/29	40/20	40/20	40/20	46/23
	Bank6	40/20	54/27	60/30	62/31	66/33	62/31	82/41
	Bank7	40/20	60/30	64/32	70/35	74/37	70/35	90/45
	Bank8	0/0	0/0	0/0	0/0	0/0	0/0	0/0
True LVDS I/O Pairs per Bank	Bank0 (Top Edge)	0	0	0	0	0	0	0
	Bank1 (Top Edge)	0	0	0	0	0	0	0
	Bank2 (Right Edge)	7	12	13	17	18	17	20
	Bank3 (Right Edge)	9	11	11	15	16	15	20
	Bank4 (Bottom Edge)	0	0	0	0	0	0	0
	Bank5 (Bottom Edge)	0	0	0	0	0	0	0
	Bank6 (Left Edge)	10	14	15	15	16	15	20
	Bank7 (Left Edge)	10	15	17	17	18	17	22
	Bank8 (Right Edge)	0	0	0	0	0	0	0

LatticeECP2M Pin Information Summary, LFE2M50, LFE2M70 and LFE2M100 (Cont.)

Pin Type		LFE2M50			LFE2M70		LFE2M100	
		484 fpBGA	672 fpBGA	900 fpBGA	900 fpBGA	1152 fpBGA	900 fpBGA	1152 fpBGA
Available DDR-Interfaces per I/O Bank ¹	Bank0	0	0	0	0	0	0	0
	Bank1	0	0	0	0	0	0	0
	Bank2	2	4	2	4	4	4	4
	Bank3	2	3	1	3	4	3	5
	Bank4	3	1	3	3	3	3	3
	Bank5	2	3	3	2	3	2	3
	Bank6	1	3	2	3	4	3	5
	Bank7	3	4	3	4	4	4	5
	Bank8	0	0	0	0	0	0	0
PCI Capable I/Os per Bank	Bank0	0	0	0	0	0	0	0
	Bank1	0	0	0	0	0	0	0
	Bank2	0	0	0	0	72	0	80
	Bank3	0	0	0	0	64	0	80
	Bank4	50	24	48	48	40	48	44
	Bank5	60	60	50	40	40	40	46
	Bank6	52	54	60	62	66	62	82
	Bank7	60	60	68	70	74	70	90
	Bank8	0	0	0	0	0	0	0

1. Minimum requirement to implement a fully functional 8-bit wide DDR bus. Available DDR interface consists of at least 12 I/Os (1 DQS + 1 DQSB + 8 DQs + 1 DM + Bank VREF1).

Available Device Resources by Package, LatticeECP2

Resource	Device	256 fpBGA	484 fpBGA	672 fpBGA	900 fpBGA
PLL/DLL	ECP2-6	4	—	—	—
	ECP2-12	4	4	—	—
	ECP2-20	4	4	4	—
	ECP2-35	—	4	4	—
	ECP2-50	—	6	6	—
	ECP2-70	—	—	8	8

Available Device Resources by Package, LatticeECP2M

Resource	Device	256 fpBGA	484 fpBGA	672 fpBGA	900 fpBGA	1152 fpBGA
PLL/DLL	ECP2M20	10	10	—	—	—
	ECP2M35	10	10	10	—	—
	ECP2M50	—	10	10	10	—
	ECP2M70	—	—	—	10	10
	ECP2M100	—	—	—	10	10

LatticeECP2 Power Supply and NC

Signals	144 TQFP ³	208 PQFP ³	256 fpBGA ⁴	484 fpBGA ⁴
VCC	16, 22, 29, 48, 54, 83, 94, 102, 128, 135	12, 19, 28, 40, 74, 80, 97, 116, 129, 140, 146, 171, 188, 198	LFE2-6: G7, G9, G10, H7, J10, K10, K8 LFE2-12/LFE2-20: G7, G9, G10, H7, J10, K10, K8	LFE2-12/LFE2-20: N6, N18, J10, J11, J12, J13, K14, K9, L14, L9, M14, M9, N14, N9, P10, P11, P12, P13 LFE2-35/LFE2-50: J10, J11, J12, J13, K14, K9, L14, L9, M14, M9, N14, N9, P10, P11, P12, P13
VCCIO0	139	195, 206	C5, E7	G10, G9, H8, H9
VCCIO1	117	162, 170	C12, E10	G11, G12, G13, G14
VCCIO2	106	143, 148	E14, G12	H14, H15, J15, K16
VCCIO3	89	123, 135	K12, M14	L16, M16, N16, P16
VCCIO4	64	93, 100	M10, P12	R14, T12, T13, T14
VCCIO5	42	55, 63	M7, P5	R9, T10, T11, T9
VCCIO6	31	38, 44	K5, M3	N7, P7, P8, R8
VCCIO7	9	10, 14	E3, G5	J8, K7, L7, M7
VCCIO8	85	113, 118	T15	P15, R15
VCCJ	35	51	K7	T8
VCCAUX	6, 39, 90, 142	7, 30, 70, 86, 125, 151, 174, 190	G8, H10, J7, K9	G5, K5, R5, V7, V11, V8, V13, V15, M17, P17, E17, G18, D11, F13, C5, E6
VCCPLL	None	None	None	LFE2-12/LFE2-20: None LFE2-35: N6, N18 LFE2-50: N6, N18, K6, J16
GND ¹	11, 21, 30, 47, 51, 61, 81, 95, 105, 120, 133, 138	5, 13, 17, 25, 32, 42, 60, 68, 77, 81, 89, 102, 115, 122, 139, 145, 159, 169, 175, 184, 192, 201	A1, A16, B12, B5, C8, E15, E2, H14, H8, H9, J3, J8, J9, M15, M2, P9, R12, R5, T1, T16	A22, AA19, AA4, AB1, AB22, B19, B4, C14, C9, D2, D21, F17, F6, H10, H11, H12, H13, J14, J20, J3, J9, K10, K11, K12, K13, K15, K8, L10, L11, L12, L13, L15, L8, M10, M11, M12, M13, M15, M8, N10, N11, N12, N13, N15, N8, P14, P20, P3, P9, R10, R11, R12, R13, U17, U6, W2, W21, Y14, Y9, A1
NC ²	LFE2-6: 45, 46, 124, 127 LFE2-12: 127	None	LFE2-6: K6, R3, P4 LFE2-12/LFE2-20: None	LFE2-12: E3, F3, F1, H4, F2, H5, G1, G3, G2, G4, K6, N1, M2, N2, M1, N3, N5, N4, P5, N19, M19, J22, L22, H22, K22, J16, D22, F21, E21, E22, H19, G20, G19, F20, C21, C22, H6, J6, H3, H2, H17, H16, H20, H18 LFE2-20/LFE2-35: K6, J16, H6, J6, H3, H2, H17, H16, H20, H18 LFE2-50: None

1. All grounds must be electrically connected at the board level. For fpBGA packages, the total number of GND balls is less than the actual number of GND logic connections from the die to the common package GND plane.
2. NC pins should not be connected to any active signals, VCC or GND.
3. Pin orientation follows the conventional order from the pin 1 marking of the top side view and counter-clockwise.
4. Pin orientation A1 starts from the upper left corner of the top side view with alphabetical order ascending vertically and numerical order ascending horizontally.

LatticeECP2 Power Supply and NC (Cont.)

Signals	672 fpBGA ³	900 fpBGA ³
VCC	LFE2-20: R8, P18, M8, L20, L12, L13, L14, L15, M11, M12, M15, M16, N11, N16, P11, P16, R11, R12, R15, R16, T12, T13, T14, T15 LFE2-35/LFE2-50: L12, L13, L14, L15, M11, M12, M15, M16, N11, N16, P11, P16, R11, R12, R15, R16, T12, T13, T14, T15 LFE2-70: L12, L13, L14, L15, M11, M12, M15, M16, N11, N16, P11, P16, R11, R12, R15, R16, T12, T13, T14, T15	AA11, AA20, K11, K21, K22, L11, L12, L13, L18, L19, L20, M11, M20, N11, N20, V11, V20, W11, W20, Y10, Y11, Y12, Y13, Y18, Y19, Y20
VCCIO0	D11, D6, G9, J12, K12	J13, J14, K12, K13, K14, K15
VCCIO1	D16, D21, G18, J15, K15	J17, J18, J20, K17, K18, K20
VCCIO2	F23, J20, L23, M17, M18	L21, M21, M22, N21, N22, R21
VCCIO3	AA23, R17, R18, T23, V20	U21, U22, V21, V22, W21, Y22
VCCIO4	AC16, AC21, U15, V15, Y18	AA16, AA17, AA18, AA19, AB17, AB18
VCCIO5	AC11, AC6, U12, V12, Y9	AA12, AA13, AA14, AB12, AB13, AB14
VCCIO6	AA4, R10, R9, T4, V7	U10, U9, V10, W10, W9, Y9
VCCIO7	F4, J7, L4, M10, M9	L10, L9, M10, N10, P10, R10
VCCIO8	AE25, V18	AA21, Y21
VCCJ	AB5	AD3
VCCAUX	J10, J11, J16, J17, K18, L18, T18, U18, V16, V17, V10, V11, T9, U9, K9, L9	AA15, AB11, AB19, AB20, J11, J12, J19, K19, L22, M9, N9, P21, P9, T10, T21, V9, W22
VCCPLL	LFE2-20: None LFE2-35/LFE2-70: R8, P18 LFE2-50: R8, P18, M8, L20	P22, P8, T22, Y7
GND ¹	A2, A25, AA18, AA24, AA3, AA9, AD11, AD16, AD21, AD6, AE1, AE26, AF2, AF25, B1, B26, C11, C16, C21, C6, F18, F24, F3, F9, J13, J14, J21, J6, K10, K11, K13, K14, K16, K17, L10, L11, L16, L17, L24, L3, M13, M14, N10, N12, N13, N14, N15, N17, P10, P12, P13, P14, P15, P17, R13, R14, T10, T11, T16, T17, T24, T3, U10, U11, U13, U14, U16, U17, V13, V14, V21, V6	A1, A30, AC28, AC3, AH13, AH18, AH23, AH28, AH3, AH8, AK1, AK30, C13, C18, C23, C28, C3, C8, H28, H3, L14, L15, L16, L17, M12, M13, M14, M15, M16, M17, M18, M19, N12, N13, N14, N15, N16, N17, N18, N19, N28, N3, P11, P12, P13, P14, P15, P16, P17, P18, P19, P20, R11, R12, R13, R14, R15, R16, R17, R18, R19, R20, T11, T12, T13, T14, T15, T16, T17, T18, T19, T20, U11, U12, U13, U14, U15, U16, U17, U18, U19, U20, V12, V13, V14, V15, V16, V17, V18, V19, V28, V3, W12, W13, W14, W15, W16, W17, W18, W19, Y14, Y15, Y16, Y17
NC ²	LFE2-20: E4, E3, E2, E1, H6, H5, F2, F1, H8, J9, G4, G3, K3, K2, K1, L2, L1, M2, M1, N2, T1, T2, P8, P6, P5, P4, U1, V1, P3, R3, R4, U2, V2, W2, T6, R5, AA19, W17, Y19, Y17, AF20, AE20, AA20, W18, AD20, AE21, AF21, AF22, R22, T21, P26, P25, R24, R23, P20, R19, P21, P19, P23, P22, N22, R21, N26, N25, J26, J25, J23, K23, H26, H25, H24, H23, F22, E24, D25, C25, D24, B25, H21, G22, B24, C24, D23, C23, E19, C19, B21, B20, D19, B19, G17, E18, G19, F17, A20, A19, E17, D18, M3, N6, P24 LFE2-35: K3, K2, K1, L2, L1, M2, M1, N2, M8, P3, R3, R4, U2, V2, W2, AF20, AE20, AA20, W18, AD20, AE21, AF21, AF22, P26, P25, R24, R23, P20, R19, L20, J26, J25, J23, K23, H26, H25, H24, H23, E19, C19, B21, B20, D19, B19, G17, E18, G19, F17, A20, A19, E17, D18, M3, N6, P24 LFE2-50: N6, P24, M3 LFE2-70: M8, L20, M3, P24, N6	A2, A3, A4, A5, AB28, AC4, AD23, AE1, AE2, AE29, AE3, AE30, AE4, AE5, AE6, AF1, AF2, AF23, AF26, AF27, AF28, AF29, AF3, AF30, AF4, AF5, AG1, AG13, AG16, AG18, AG2, AG26, AG27, AG28, AG29, AG3, AG30, AG4, AG8, AH1, AH16, AH2, AH26, AH27, AH29, AH30, AH4, AJ1, AJ2, AJ27, AJ28, AJ29, AJ3, AJ30, AK2, AK27, AK28, AK29, AK3, B1, B2, B3, B30, B4, B5, C1, C2, C29, C30, C4, D13, D18, D23, D28, D29, D3, D30, D4, E25, E26, E27, E28, E29, E3, E30, E4, E5, E6, F25, F5, F6, G6, G7, K10, K9, N27, N4, R1, R2, V27, V4

1. All grounds must be electrically connected at the board level. For fpBGA packages, the total number of GND balls is less than the actual number of GND logic connections from the die to the common package GND plane.

2. NC pins should not be connected to any active signals, VCC or GND.

3. Pin orientation A1 starts from the upper left corner of the top side view with alphabetical order ascending vertically and numerical order ascending horizontally.

LatticeECP2M Power Supply and NC

Signal	256 fpBGA	484 fpBGA
V _{CC}	G7, G9, H7, J10, K10, K8	J10, J11, J12, J13, K14, K9, L14, L9, M14, M9, N14, N9, P10, P11, P12, P13
V _{CCIO0}	E7	B5, B9, E7, H9
V _{CCIO1}	E10	D13, E16, H14
V _{CCIO2}	E14, G12	E21, G18, J15, K19
V _{CCIO3}	K12, M14	N19, P15, T18, V21
V _{CCIO4}	M10, P12	AA18, R14, V16, W13
V _{CCIO5}	M7, P5	AA5, R9, V7, W10
V _{CCIO6}	K5, M3	N4, P8, T5, V2
V _{CCIO7}	E3, G5	E2, G5, J8, K4
V _{CCIO8}	T15	AA22, U19
V _{CCJ}	K7	W4
V _{CCAUX}	G8, H10, J7, K9	H11, H12, L15, L8, M15, M8, R11, R12
V _{CCPLL}	G10	R8, H15, H8, R15
SERDES Power ³	C15, B15, C12, A12, C11, C10, C14, C13, B9, C9, C5, C4, C8, C7, A6, C6, B3, C3	C22, B22, C19, A19, C18, C17, C21, C20, B16, C16, C12, C11, C15, C14, A13, C13, B10, C10
GND ¹	A1, A15, A16, A3, A9, B12, B6, E15, E2, H14, H8, H9, J3, J8, J9, M15, M2, P9, R12, R5, T1, T16	A1, A10, A16, A22, AA19, AA4, AB1, AB22, B13, B19, B4, D16, D2, D21, D7, G19, G4, H10, H13, J14, J9, K10, K11, K12, K13, K15, K20, K3, K8, L10, L11, L12, L13, M10, M11, M12, M13, N10, N11, N12, N13, N15, N20, N3, N8, P14, P9, R10, R13, T19, T4, W16, W2, W21, W7, Y10, Y13
NC ²	D10, D11, D12, D13, D14, D4, D5, D6, D7, E11, E6, E8, E9, F10, F7, F8, F9	LFE2M20: D14, D15, E14, E15, F13, F14, F15, G12, G13, G14, G15 LFE2M35: D14, D15, E14, E15, F13, F14, F15, G12, G13, G14, G15, U6 LFE2M50: Y15, W15, AB20, AB21, AA20, AB19, AB18, Y22, Y21, Y17, Y18, Y16, W17, Y19, Y20, W19, W18, V17, V18, D15, G14, G15, D14, E15, E14, F15, F14, F13, G12, G13

1. All grounds must be electrically connected at the board level. For fpBGA packages, the total number of GND balls is less than the actual number of GND logic connections from the die to the common package GND plane.
2. NC pins should not be connected to any active signals, VCC or GND.
3. For package migration across device densities, the designer must comprehend the package pin requirements for the SERDES blocks. Specifically, the SERDES power pins of the largest density device must be accounted to accommodate migration to other smaller devices using the same package. Please refer to technical note TN1160, *LatticeECP2/M Density Migration*, for more details.

LatticeECP2M Power Supply and NC (Cont.)

Signal	672 fpBGA	900 fpBGA
V _{CC}	<p>LFE2M35: AD13, AD14, AD16, AD17, AD19, AD21, AD22, AD24, AD25, L12, L13, L14, L15, M11, M12, M15, M16, N11, N16, P11, P16, R11, R12, R15, R16, T12, T13, T14, T15</p> <p>LFE2M50: L12, L13, L14, L15, M11, M12, M15, M16, N11, N16, P11, P16, R11, R12, R15, R16, T12, T13, T14, T15</p>	<p>LFE2M50: AH1, AH4, AH5, AH2, AH7, AH12, AH9, AH10, AH13, C13, C10, C9, C12, C7, C2, C5, C4, C1, L12, L13, L18, L19, M11, M12, M13, M14, M15, M16, M17, M18, M19, M20, N11, N12, N19, N20, P12, P19, R12, R19, T12, T19, U12, U19, V11, V12, V19, V20, W11, W12, W13, W14, W15, W16, W17, W18, W19, W20, Y12, Y13, Y18, Y19</p> <p>LFE2M70/LFE2M100: L12, L13, L18, L19, M11, M12, M13, M14, M15, M16, M17, M18, M19, M20, N11, N12, N19, N20, P12, P19, R12, R19, T12, T19, U12, U19, V11, V12, V19, V20, W11, W12, W13, W14, W15, W16, W17, W18, W19, W20, Y12, Y13, Y18, Y19</p>
V _{CCIO0}	B12, B7, F11, J13, K12	D14, E6, E9, F12, K12, K13
V _{CCIO1}	D18, F16, J14, K15	D17, E22, E25, F19, K18, K19
V _{CCIO2}	G25, L21, M17, M25, N18	F28, J25, K28, M21, M24, N21, N28, P21, R25
V _{CCIO3}	P18, R17, R25, T21, Y25	AA28, AB25, AE28, T25, U21, V21, V28, W21, W24
V _{CCIO4}	AA16, AC18, U15, V14	AA18, AA19, AE19, AF22, AG17, AG25
V _{CCIO5}	AA11, AE12, AE7, U12, V13	AA12, AA13, AE12, AF9, AG14, AG6
V _{CCIO6}	P9, R10, R2, T6, Y2	AA3, AB6, AE3, T6, U10, V10, V3, W10, W7
V _{CCIO7}	G2, L6, M10, M2, N9	F3, J6, K3, M10, M7, N10, N3, P10, R6
V _{CCIO8}	AC24, U17	AA25, AD28
V _{CCJ}	AA7	AG1
V _{CCAUX}	<p>LFE2M35: AE19, J11, J12, J15, J16, L18, L9, M18, M9, R18, R9, T18, T9, V11, V12, V15, V16</p> <p>LFE2M50: J11, J12, J15, J16, L18, L9, M18, M9, R18, R9, T18, T9, V11, V12, V15, V16</p>	<p>LFE2M50: AJ7, B7, AA10, AA11, AA20, AA21, K10, K11, K20, K21, L10, L11, L20, L21, Y10, Y11, Y20, Y21</p> <p>LFE2M70/LFE2M100: AA10, AA11, AA20, AA21, K10, K11, K20, K21, L10, L11, L20, L21, Y10, Y11, Y20, Y21</p>
V _{CCPLL}	H7, K6, P7, R8, V18, P20, J17, G19	N13, N18, V13, V18
SERDES Power ³	<p>LFE2M35: C25, B25, C22, A22, C21, C20, C24, C23, B19, C19, C15, C14, C18, C17, A16, C16, B13, C13</p> <p>LFE2M50: AD13, AE13, AD16, AF16, AD17, AD18, AD14, AD15, AD19, AE19, AD23, AD24, AD20, AD21, AF22, AD22, AE25, AD25, C25, B25, C22, A22, C21, C20, C24, C23, B19, C19, C15, C14, C18, C17, A16, C16, B13, C13</p>	<p>LFE2M50: AH18, AJ18, AH21, AK21, AH22, AH23, AH19, AH20, AH24, AJ24, AH28, AH29, AH25, AH26, AK27, AH27, AJ30, AH30, C30, B30, C27, A27, C26, C25, C29, C28, B24, C24, C20, C19, C23, C22, A21, C21, B18, C18</p> <p>LFE2M70/LFE2M100: C13, B13, C10, A10, C9, C8, C12, C11, B7, C7, C3, C2, C6, C5, A4, C4, B1, C1, C30, B30, C27, A27, C26, C25, C29, C28, B24, C24, C20, C19, C23, C22, A21, C21, B18, C18, AH18, AJ18, AH21, AK21, AH22, AH23, AH19, AH20, AH24, AJ24, AH28, AH29, AH25, AH26, AK27, AH27, AJ30, AH30, AH1, AJ1, AH4, AK4, AH5, AH6, AH2, AH3, AH7, AJ7, AH11, AH12, AH8, AH9, AK10, AH10, AJ13, AH13</p>

LatticeECP2M Power Supply and NC (Cont.)

Signal	672 fpBGA	900 fpBGA
GND ¹	A13, A19, A2, A25, AA2, AA25, AB18, AB22, AB5, AB9, AE1, AE11, AE16, AE22, AE26, AE6, AF13, AF19, AF2, AF25, B1, B11, B16, B22, B26, B6, E18, E22, E5, E9, F2, F25, G11, G16, J22, J5, K11, K13, K14, K16, L10, L11, L16, L17, L2, L20, L25, L7, M13, M14, N10, N12, N13, N14, N15, N17, P10, P12, P13, P14, P15, P17, R13, R14, T10, T11, T16, T17, T2, T20, T25, T7, U11, U13, U14, U16, V22, V5, Y11, Y16	<p>LFE2M50: A1, A13, A18, A24, A30, A7, AA14, AA15, AA16, AA17, AA24, AA27, AA4, AB24, AB7, AD12, AD19, AD27, AE22, AE27, AE4, AE9, AF14, AF17, AF25, AF6, AJ10, AJ21, AJ27, AJ4, AK1, AK13, AK18, AK24, AK30, AK7, B10, B21, B27, B4, D25, D6, E14, E17, F22, F27, F4, F9, G12, G19, J24, J7, K14, K15, K16, K17, K27, K4, L14, L15, L16, L17, M23, M8, N14, N15, N16, N17, N27, N4, P11, P13, P14, P15, P16, P17, P18, P20, R10, R11, R13, R14, R15, R16, R17, R18, R20, R21, R24, R7, T10, T11, T13, T14, T15, T16, T17, T18, T20, T21, T24, T7, U11, U13, U14, U15, U16, U17, U18, U20, V14, V15, V16, V17, V27, V4, W23, W8, Y14, Y15, Y16, Y17</p> <p>LFE2M70/LFE2M100: A1, A13, A18, A24, A30, A7, AA14, AA15, AA16, AA17, AA24, AA27, AA4, AB24, AB7, AD12, AD19, AD27, AE22, AE27, AE4, AE9, AF14, AF17, AF25, AF6, AJ10, AJ21, AJ27, AJ4, AK1, AK13, AK18, AK24, AK30, AK7, B10, B21, B27, B4, D25, D6, E14, E17, F22, F27, F4, F9, G12, G19, J24, J7, K14, K15, K16, K17, K27, K4, L14, L15, L16, L17, M23, M8, N15, N16, N17, N27, N4, P11, P13, P14, P15, P16, P17, P18, P20, R10, R11, R13, R14, R15, R16, R17, R18, R20, R21, R24, R7, T10, T11, T13, T14, T15, T16, T17, T18, T20, T21, T24, T7, U11, U13, U14, U15, U16, U17, U18, U20, V14, V15, V16, V17, V27, V4, W23, W8, Y14, Y15, Y16, Y17</p>
NC ²	<p>LFE2M35: AB3, AB4, AC1, AC2, AD15, AD18, AD20, AD23, AE13, AE25, AF16, AF22, B4, B5, C26, D20, D21, D22, D23, D24, D25, D26, E20, E21, E25, E26, F20, G20, K10, K17, R4, U10, U23, V10, W7, N7, V7</p> <p>LFE2M50: AB3, AB4, AC1, AC2, B4, B5, C26, D20, D21, D22, D23, D24, D25, D26, E20, E21, E25, E26, F20, G20, K10, K17, R4, U10, U23, V10, W7, AB21, AC20, AC21, AC22, AC23, AC25, AD26, W20</p>	<p>LFE2M50: G5, G4, K7, K8, E1, F2, F1, G3, G2, G1, L9, L7, K6, K5, L8, L6, AA1, AA2, Y3, AB1, Y9, Y8, Y7, AA7, AB2, AB3, AA5, AA6, AB4, AB5, AA8, AA9, AJ1, AK4, AH6, AH3, AH11, AH8, AK10, AJ13, AB26, AB27, Y24, Y25, AA29, Y28, Y30, Y29, W22, V22, Y27, Y26, W30, W29, W25, W26, L24, L23, D30, D29, K24, K25, J27, K26, J26, H26, H27, G26, H23, H24, D28, E28, J18, J19, H17, J17, F18, F17, B13, A10, C8, C11, C3, C6, A4, B1, AA26, AB11, AB12, AB13, AB14, AB15, AB16, AB17, AB19, AB20, AB21, AC11, AC21, AC22, AD21, AD22, AE23, AF20, AF23, AG23, AG26, F20, F23, G10, G20, G21, H19, H20, H21, H22, J20, J21, R9, U22, W9</p> <p>LFE2M70/LFE2M100: AA26, AB10, AB11, AB12, AB13, AB14, AB15, AB16, AB17, AB19, AB20, AB21, AB9, AC10, AC11, AC21, AC22, AC8, AC9, AD21, AD22, AD4, AD5, AD6, AD7, AD8, AE23, AE5, AE6, AE7, AF20, AF23, AF5, AG23, AG26, D10, E10, E11, F10, F20, F23, F8, G10, G20, G21, G7, G8, G9, H19, H20, H21, H22, H6, H8, H9, J10, J20, J21, J9, K9, R9, U22, W9</p>

1. All grounds must be electrically connected at the board level. For fpBGA packages, the total number of GND balls is less than the actual number of GND logic connections from the die to the common package GND plane.
2. NC pins should not be connected to any active signals, VCC or GND.
3. For package migration across device densities, the designer must comprehend the package pin requirements for the SERDES blocks. Specifically, the SERDES power pins of the largest density device must be accounted to accommodate migration to other smaller devices using the same package. Please refer to technical note TN1160, *LatticeECP2/M Density Migration*, for more details.

LatticeECP2M Power Supply and NC (Cont.)

Signal	1152 fpBGA
V _{CC}	AA13, AA14, AA15, AA16, AA17, AA18, AA19, AA20, AA21, AA22, AB14, AB15, AB20, AB21, N14, N15, N20, N21, P13, P14, P15, P16, P17, P18, P19, P20, P21, P22, R13, R14, R21, R22, T14, T21, U14, U21, V14, V21, W14, W21, Y13, Y14, Y21, Y22
V _{CCI00}	C12, C16, E14, H12, H16, M14, M15
V _{CCI01}	C19, C23, E21, H19, H23, M20, M21
V _{CCI02}	G32, K28, K32, N27, N32, P23, R23, T27, T32
V _{CCI03}	AA23, AB27, AB32, AE28, AE32, AH32, W27, W32, Y23
V _{CCI04}	AC20, AC21, AG19, AG23, AK21, AM19, AM23
V _{CCI05}	AC14, AC15, AG12, AG16, AK14, AM12, AM16
V _{CCI06}	AA12, AB3, AB8, AE3, AE7, AH3, W3, W8, Y12
V _{CCI07}	G3, K3, K7, N3, N8, P12, R12, T3, T8
V _{CCI08}	AD28, AG32
V _{CCJ}	AK3
V _{CCAUX}	AB12, AB13, AB22, AB23, AC13, AC22, M13, M22, N12, N13, N22, N23
V _{CCPLL}	R15, R20, Y15, Y20
SERDES Power ³	D7, B9, B8, D9, B7, E7, B6, D8, E6, D6, D4, B5, D3, B4, C1, B3, B1, B2, B33, B34, B32, C34, B31, D32, B30, D31, E29, D29, D27, B29, E28, B28, D26, B27, B26, D28, AL28, AN26, AN27, AL26, AN28, AK28, AN29, AL27, AL29, AK29, AL31, AN30, AL32, AN31, AM34, AN32, AN34, AN33, AN2, AN1, AN3, AM1, AN4, AL3, AN5, AL4, AL6, AK6, AL8, AN6, AK7, AN7, AL9, AN8, AN9, AL7
GND ¹	A1, A10, A13, A22, A25, A34, AB16, AB17, AB18, AB19, AB26, AB31, AB4, AB9, AC16, AC17, AC18, AC19, AD27, AE27, AE31, AE4, AE8, AF12, AF16, AF19, AF23, AG31, AH31, AH4, AJ14, AJ21, AK27, AK8, AL10, AL16, AL19, AL2, AL25, AL33, AP1, AP10, AP13, AP22, AP25, AP34, D10, D16, D19, D2, D25, D33, E27, E8, F14, F21, G31, G4, J12, J16, J19, J23, K27, K31, K4, K8, M16, M17, M18, M19, N16, N17, N18, N19, N26, N31, N4, N9, R16, R17, R18, R19, T12, T13, T15, T16, T17, T18, T19, T20, T22, T23, T26, T31, T4, T9, U12, U13, U15, U16, U17, U18, U19, U20, U22, U23, V12, V13, V15, V16, V17, V18, V19, V20, V22, V23, W12, W13, W15, W16, W17, W18, W19, W20, W22, W23, W26, W31, W4, W9, Y16, Y17, Y18, Y19
NC ²	LFE2M70: H2, H1, G5, G6, M9, M10, H3, H4, P3, P4, P9, M7, P1, P2, N7, P7, AC7, AC5, AC6, AD5, AD4, AD3, AD10, AD8, AD2, AD1, AD9, AC11, AD6, AD7, AE1, AE2, AJ12, AH12, AL13, AK13, AE14, AG13, AH22, AH21, AG22, AG21, AF33, AF34, AC27, AC28, AD29, AD30, AE33, AE34, AD32, AD31, AB25, AC25, AB28, AA26, AD33, AD34, P30, P29, P31, P32, R25, T24, N34, N33, F24, G23, J22, G22, H21, K21, L19, L20, L18, K19, J14, L15, H14, K14, F12, D11, F11, E11, A11, A12, A23, A24, AA11, AB11, AC26, AC30, AD11, AD12, AD13, AD14, AD15, AD19, AD21, AD22, AD23, AE10, AE11, AE12, AE13, AE19, AE21, AE22, AE23, AF11, AF21, AF22, AF24, AF8, AF9, AG10, AG11, AG24, AG25, AG26, AG3, AG7, AG8, AG9, AH10, AH11, AH13, AH24, AH25, AH26, AH27, AH5, AH6, AH7, AH8, AH9, AJ10, AJ11, AJ13, AJ24, AJ25, AJ26, AJ27, AJ3, AJ4, AJ5, AJ6, AJ7, AJ8, AJ9, AK10, AK11, AK12, AK24, AK25, AK26, AK4, AK9, AL11, AL12, AL34, AM10, AM11, AM13, AM25, AN10, AN11, AN12, AN13, AN24, AN25, AP11, AP12, AP24, B10, B11, B12, B13, B22, B23, B24, B25, C10, C11, C13, C22, C24, C25, D1, D15, D24, D34, E10, E24, E25, E26, E3, E31, E32, E33, E34, E4, E9, F10, F25, F26, F27, F28, F29, F30, F31, F32, F33, F34, F5, F6, F7, F8, F9, G10, G11, G24, G25, G26, G27, G28, G29, G30, G33, G34, G7, G8, G9, H10, H11, H24, H25, H26, H27, H28, H29, H8, H9, J10, J11, J24, J25, J26, J9, K10, K11, K12, K13, K23, K24, K25, K26, L11, L12, L13, L14, L21, L22, L23, L24, L25, L26, M11, M24, M25, M6, M8, N10, N11, P10, P25, P26, R9, T11, U11, W11, Y10, Y11 LFE2M100: A11, A12, A23, A24, AA11, AB11, AC26, AC30, AD11, AD12, AD13, AD14, AD15, AD19, AD21, AD22, AD23, AE10, AE11, AE12, AE13, AE19, AE21, AE22, AE23, AF11, AF21, AF22, AF24, AF8, AF9, AG10, AG11, AG24, AG25, AG26, AG3, AG7, AG8, AG9, AH10, AH11, AH13, AH24, AH25, AH26, AH27, AH5, AH6, AH7, AH8, AH9, AJ10, AJ11, AJ13, AJ24, AJ25, AJ26, AJ27, AJ3, AJ4, AJ5, AJ6, AJ7, AJ8, AJ9, AK10, AK11, AK12, AK24, AK25, AK26, AK4, AK9, AL11, AL12, AL34, AM10, AM11, AM13, AM25, AN10, AN11, AN12, AN13, AN24, AN25, AP11, AP12, AP24, B10, B11, B12, B13, B22, B23, B24, B25, C10, C11, C13, C22, C24, C25, D1, D15, D24, D34, E10, E24, E25, E26, E3, E31, E32, E33, E34, E4, E9, F10, F25, F26, F27, F28, F29, F30, F31, F32, F33, F34, F5, F6, F7, F8, F9, G10, G11, G24, G25, G26, G27, G28, G29, G30, G33, G34, G7, G8, G9, H10, H11, H24, H25, H26, H27, H28, H29, H8, H9, J10, J11, J24, J25, J26, J9, K10, K11, K12, K13, K23, K24, K25, K26, L11, L12, L13, L14, L21, L22, L23, L24, L25, L26, M11, M24, M25, M6, M8, N10, N11, P10, P25, P26, R9, T11, U11, W11, Y10, Y11

- All grounds must be electrically connected at the board level. For fpBGA packages, the total number of GND balls is less than the actual number of GND logic connections from the die to the common package GND plane.
- NC pins should not be connected to any active signals, VCC or GND.
- For package migration across device densities, the designer must comprehend the package pin requirements for the SERDES blocks. Specifically, the SERDES power pins of the largest density device must be accounted to accommodate migration to other smaller devices using the same package. Please refer to technical note TN1160, *LatticeECP2M Density Migration*, for more details.

LFE2-6E/SE and LFE2-12E/SE Logic Signal Connections: 144 TQFP

LFE2-6E/SE					LFE2-12E/12SE				
Pin Number	Pin/Pad Function	Bank	Dual Function	Differential	Pin/Pad Function	Bank	Dual Function	Differential	
1	PL2A	7	VREF2_7	T (LVDS)*	PL2A	7	VREF2_7	T (LVDS)*	
2	PL2B	7	VREF1_7	C (LVDS)*	PL2B	7	VREF1_7	C (LVDS)*	
3	PL4A	7		T (LVDS)*	PL4A	7		T (LVDS)*	
4	PL4B	7		C (LVDS)*	PL4B	7		C (LVDS)*	
5	PL6A	7	LDQ10	T (LVDS)*	PL6A	7	LDQ10	T (LVDS)*	
6	VCCAUX	-			VCCAUX	-			
7	PL6B	7	LDQ10	C (LVDS)*	PL6B	7	LDQ10	C (LVDS)*	
8	PL8A	7	LDQ10	T (LVDS)*	PL8A	7	LDQ10	T (LVDS)*	
9	VCCIO7	7			VCCIO7	7			
10	PL8B	7	LDQ10	C (LVDS)*	PL8B	7	LDQ10	C (LVDS)*	
11	GND	-			GND	-			
12	PL12A	7	LDQ10	T (LVDS)*	PL12A	7	LDQ10	T (LVDS)*	
13	PL12B	7	LDQ10	C (LVDS)*	PL12B	7	LDQ10	C (LVDS)*	
14	PL13A	7	PCLKT7_0/LDQ10	T	PL13A	7	PCLKT7_0/LDQ10	T	
15	PL13B	7	PCLKC7_0/LDQ10	C	PL13B	7	PCLKC7_0/LDQ10	C	
16	VCC	-			VCC	-			
17	PL15A	6	PCLKT6_0	T (LVDS)*	PL15A	6	PCLKT6_0	T (LVDS)*	
18	PL15B	6	PCLKC6_0	C (LVDS)*	PL15B	6	PCLKC6_0	C (LVDS)*	
19	PL16A	6	VREF2_6	T	PL16A	6	VREF2_6	T	
20	PL16B	6	VREF1_6	C	PL16B	6	VREF1_6	C	
21	GND	-			GND	-			
22	VCC	-			VCC	-			
23	PL18A	6	LLM0_GDLLT_FB_A	T	PL18A	6	LLM0_GDLLT_FB_A	T	
24	PL18B	6	LLM0_GDLLC_FB_A	C	PL18B	6	LLM0_GDLLC_FB_A	C	
25	LLM0_PLCCAP	6			LLM0_PLCCAP	6			
26	PL20A	6	LLM0_GPLLT_IN_A**	T (LVDS)*	PL20A	6	LLM0_GPLLT_IN_A**	T (LVDS)*	
27	PL20B	6	LLM0_GPLLC_IN_A**	C (LVDS)*	PL20B	6	LLM0_GPLLC_IN_A**	C (LVDS)*	
28	PL22A	6			PL22A	6			
29	VCC	-			VCC	-			
30	GND	-			GND	-			
31	VCCIO6	6			VCCIO6	6			
32	TCK	-			TCK	-			
33	TDI	-			TDI	-			
34	TDO	-			TDO	-			
35	VCCJ	-			VCCJ	-			
36	TMS	-			TMS	-			
37	PB2A	5	VREF2_5/BDQ6	T	PB2A	5	VREF2_5/BDQ6	T	
38	PB2B	5	VREF1_5/BDQ6	C	PB2B	5	VREF1_5/BDQ6	C	
39	VCCAUX	-			VCCAUX	-			
40	PB4A	5	BDQ6	T	PB6A	5	BDQS6	T	
41	PB4B	5	BDQ6	C	PB6B	5	BDQ6	C	
42	VCCIO5	5			VCCIO5	5			
43	PB6A	5	BDQS6	T	PB12A	5	BDQ15	T	
44	PB6B	5	BDQ6	C	PB12B	5	BDQ15	C	
45	NC	5			PB16A	5	BDQ15	T	

LFE2-6E/SE and LFE2-12E/SE Logic Signal Connections: 144 TQFP (Cont.)

LFE2-6E/SE					LFE2-12E/12SE			
Pin Number	Pin/Pad Function	Bank	Dual Function	Differential	Pin/Pad Function	Bank	Dual Function	Differential
46	NC	5			PB16B	5	BDQ15	C
47	GND	-			GND	-		
48	VCC				VCC	-		
49	PB8A	5	PCLKT5_0/BDQ6	T	PB26A	5	PCLKT5_0/BDQ24	T
50	PB8B	5	PCLKC5_0/BDQ6	C	PB26B	5	PCLKC5_0/BDQ24	C
51	GND	-			GND	-		
52	PB13A	4	PCLKT4_0/BDQ15	T	PB31A	4	PCLKT4_0/BDQ33	T
53	PB13B	4	PCLKC4_0/BDQ15	C	PB31B	4	PCLKC4_0/BDQ33	C
54	VCC	-			VCC	-		
55	PB14A	4	BDQ15	T	PB34A	4	BDQ33	T
56	PB14B	4	BDQ15	C	PB34B	4	BDQ33	C
57	PB16A	4	BDQ15	T	PB40A	4	BDQ42	T
58	PB16B	4	BDQ15	C	PB40B	4	BDQ42	C
59	PB18A	4	BDQ15	T	PB44A	4	BDQ42	T
60	PB18B	4	BDQ15	C	PB44B	4	BDQ42	C
61	GND	-			GND	-		
62	PB20A	4	BDQ24	T	PB48A	4	BDQ51	T
63	PB20B	4	BDQ24	C	PB48B	4	BDQ51	C
64	VCCIO4	4			VCCIO4	4		
65	PB22A	4	BDQ24	T	PB50A	4	BDQ51	T
66	PB22B	4	BDQ24	C	PB50B	4	BDQ51	C
67	PB24A	4	BDQS24	T	PB52A	4	BDQ51	T
68	PB24B	4	BDQ24	C	PB52B	4	BDQ51	C
69	PB26A	4	BDQ24	T	PB54A	4	BDQ51	T
70	PB26B	4	BDQ24	C	PB54B	4	BDQ51	C
71	PB28A	4	VREF2_4/BDQ24	T	PB55A	4	VREF2_4/BDQ51	T
72	PB28B	4	VREF1_4/BDQ24	C	PB55B	4	VREF1_4/BDQ51	C
73	CFG1	8			CFG1	8		
74	CFG2	8			CFG2	8		
75	PROGRAMN	8			PROGRAMN	8		
76	INITN	8			INITN	8		
77	CFG0	8			CFG0	8		
78	CCLK	8			CCLK	8		
79	DONE	8			DONE	8		
80	PR29A	8	D0/SPIFASTN		PR29A	8	D0/SPIFASTN	
81	GND	-			GND	-		
82	PR26A	8	D6		PR26A	8	D6	
83	VCC	-			VCC	-		
84	PR25B	8	D7	C	PR25B	8	D7	C
85	VCCIO8	8			VCCIO8	8		
86	PR25A	8	DI/CSSPI0N	T	PR25A	8	DI/CSSPI0N	T
87	PR24B	8	DOUT/CSON	C	PR24B	8	DOUT/CSON	C
88	PR24A	8	BUSY/SISPI	T	PR24A	8	BUSY/SISPI	T
89	VCCIO3	3			VCCIO3	3		
90	VCCAUX	-			VCCAUX	-		

LFE2-6E/SE and LFE2-12E/SE Logic Signal Connections: 144 TQFP (Cont.)

LFE2-6E/SE					LFE2-12E/12SE				
Pin Number	Pin/Pad Function	Bank	Dual Function	Differential	Pin/Pad Function	Bank	Dual Function	Differential	
91	PR20B	3	RLM0_GPLL_C_IN_A**	C (LVDS)*	PR20B	3	RLM0_GPLL_C_IN_A**	C (LVDS)*	
92	PR20A	3	RLM0_GPLL_T_IN_A**	T (LVDS)*	PR20A	3	RLM0_GPLL_T_IN_A**	T (LVDS)*	
93	RLM0_PLLCAP	3			RLM0_PLLCAP	3			
94	VCC	-			VCC	-			
95	GND	-			GND	-			
96	PR17B	3	RLM0_GDLL_C_IN_A**	C (LVDS)*	PR17B	3	RLM0_GDLL_C_IN_A**	C (LVDS)*	
97	PR17A	3	RLM0_GDLL_T_IN_A**	T (LVDS)*	PR17A	3	RLM0_GDLL_T_IN_A**	T (LVDS)*	
98	PR16B	3	VREF2_3	C	PR16B	3	VREF2_3	C	
99	PR16A	3	VREF1_3	T	PR16A	3	VREF1_3	T	
100	PR15B	3	PCLKC3_0	C (LVDS)*	PR15B	3	PCLKC3_0	C (LVDS)*	
101	PR15A	3	PCLKT3_0	T (LVDS)*	PR15A	3	PCLKT3_0	T (LVDS)*	
102	VCC	-			VCC	-			
103	PR13B	2	PCLKC2_0/RDQ10	C	PR13B	2	PCLKC2_0/RDQ10	C	
104	PR13A	2	PCLKT2_0/RDQ10	T	PR13A	2	PCLKT2_0/RDQ10	T	
105	GND	-			GND	-			
106	VCCIO2	2			VCCIO2	2			
107	PR2B	2	VREF2_2	C (LVDS)*	PR2B	2	VREF2_2	C (LVDS)*	
108	PR2A	2	VREF1_2	T (LVDS)*	PR2A	2	VREF1_2	T (LVDS)*	
109	PT28B	1	VREF2_1	C	PT55B	1	VREF2_1	C	
110	PT28A	1	VREF1_1	T	PT55A	1	VREF1_1	T	
111	PT26B	1		C	PT54B	1		C	
112	PT26A	1		T	PT54A	1		T	
113	PT24B	1		C	PT52B	1		C	
114	PT24A	1		T	PT52A	1		T	
115	PT22B	1		C	PT50B	1		C	
116	PT22A	1		T	PT50A	1		T	
117	VCCIO1	1			VCCIO1	1			
118	PT20B	1		C	PT48B	1		C	
119	PT20A	1		T	PT48A	1		T	
120	GND	-			GND	-			
121	PT18B	1		C	PT44B	1		C	
122	PT18A	1		T	PT44A	1		T	
123	PT16A	1			PT40B	1		C	
124	NC	1			PT40A	1		T	
125	PT14B	1		C	PT34B	1		C	
126	PT14A	1		T	PT34A	1		T	
127	NC	1			NC	1			
128	VCC	-			VCC	-			
129	PT12B	1	PCLKC1_0	C	PT30B	1	PCLKC1_0	C	
130	PT12A	1	PCLKT1_0	T	PT30A	1	PCLKT1_0	T	
131	PT10B	0	PCLKC0_0	C	PT28B	0	PCLKC0_0	C	
132	XRES	0			XRES	0			
133	GND	-			GND	-			
134	PT10A	0	PCLKT0_0	T	PT28A	0	PCLKT0_0	T	
135	VCC	-			VCC	-			

LFE2-6E/SE and LFE2-12E/SE Logic Signal Connections: 144 TQFP (Cont.)

LFE2-6E/SE					LFE2-12E/12SE			
Pin Number	Pin/Pad Function	Bank	Dual Function	Differential	Pin/Pad Function	Bank	Dual Function	Differential
136	PT6B	0		C	PT16B	0		C
137	PT6A	0		T	PT16A	0		T
138	GND	-			GND	-		
139	VCCIO0	0			VCCIO0	0		
140	PT4B	0		C	PT6B	0		C
141	PT4A	0		T	PT6A	0		T
142	VCCAUX	-			VCCAUX	-		
143	PT2B	0	VREF2_0	C	PT2B	0	VREF2_0	C
144	PT2A	0	VREF1_0	T	PT2A	0	VREF1_0	T

* Supports true LVDS. Other differential signals must be emulated with external resistors.

** These dedicated input pins can be used for GPLLs or GDLLs within the respective quadrant.

Note: VCCIO and GND pads are used to determine the average DC current drawn by I/Os between GND/VCCIO connections, or between the last GND/VCCIO in an I/O bank and the end of an I/O bank. The substrate pads listed in the Pin Table do not necessarily have a one-to-one connection with a package ball or pin.

LFE2-12E/SE and LFE2-20E/SE Logic Signal Connections: 208 PQFP

LFE2-12E/SE					LFE2-20E/SE				
Pin Number	Pin/Pad Function	Bank	Dual Function	Differential	Pin/Pad Function	Bank	Dual Function	Differential	
1	PL2A	7	VREF2_7	T (LVDS)*	PL2A	7	VREF2_7	T (LVDS)*	
2	PL2B	7	VREF1_7	C (LVDS)*	PL2B	7	VREF1_7	C (LVDS)*	
3	PL4A	7		T (LVDS)*	PL6A	7	LDQ8	T (LVDS)*	
4	PL4B	7		C (LVDS)*	PL6B	7	LDQ8	C (LVDS)*	
5	GND	-			GND	-			
6	PL6A	7	LDQ10	T (LVDS)*	PL12A	7	LDQ16	T (LVDS)*	
7	VCCAUX	-			VCCAUX	-			
8	PL6B	7	LDQ10	C (LVDS)*	PL12B	7	LDQ16	C (LVDS)*	
9	PL8A	7	LDQ10	T (LVDS)*	PL14A	7	LDQ16	T (LVDS)*	
10	VCCIO7	7			VCCIO7	7			
11	PL8B	7	LDQ10	C (LVDS)*	PL14B	7	LDQ16	C (LVDS)*	
12	VCC	-			VCC	-			
13	GND	-			GND	-			
14	VCCIO7	7			VCCIO7	7			
15	PL12A	7	LDQ10	T (LVDS)*	PL18A	7	LDQ16	T (LVDS)*	
16	PL12B	7	LDQ10	C (LVDS)*	PL18B	7	LDQ16	C (LVDS)*	
17	GND	-			GND	-			
18	PL13A	7	PCLKT7_0/LDQ10	T	PL19A	7	PCLKT7_0/LDQ16	T	
19	VCC	-			VCC	-			
20	PL13B	7	PCLKC7_0/LDQ10	C	PL19B	7	PCLKC7_0/LDQ16	C	
21	PL15A	6	PCLKT6_0	T (LVDS)*	PL21A	6	PCLKT6_0/LDQ25	T (LVDS)*	
22	PL15B	6	PCLKC6_0	C (LVDS)*	PL21B	6	PCLKC6_0/LDQ25	C (LVDS)*	
23	PL16A	6	VREF2_6	T	PL22A	6	VREF2_6/LDQ25	T	
24	PL16B	6	VREF1_6	C	PL22B	6	VREF1_6/LDQ25	C	
25	GND	-			GND	-			
26	PL17A	6	LLM0_GDLLT_IN_A**	T (LVDS)*	PL27A	6	LLM0_GDLLT_IN_A**/LDQ25	T (LVDS)*	
27	PL17B	6	LLM0_GDLLC_IN_A**	C (LVDS)*	PL27B	6	LLM0_GDLLC_IN_A**/LDQ25	C (LVDS)*	
28	VCC	-			VCC	-			
29	LLM0_PLLCAP	6			LLM0_PLLCAP	6			
30	VCCAUX	-			VCCAUX	-			
31	PL20A	6	LLM0_GPLLT_IN_A**	T (LVDS)*	PL30A	6	LLM0_GPLLT_IN_A**/LDQ34	T (LVDS)*	
32	GND	-			GND	-			
33	PL21A	6	LLM0_GPLLT_FB_A	T	PL31A	6	LLM0_GPLLT_FB_A/LDQ34	T	
34	PL20B	6	LLM0_GPLLC_IN_A**	C (LVDS)*	PL30B	6	LLM0_GPLLC_IN_A**/LDQ34	C (LVDS)*	
35	PL21B	6	LLM0_GPLLC_FB_A	C	PL31B	6	LLM0_GPLLC_FB_A/LDQ34	C	
36	PL23A	6			PL33A	6	LDQ34		
37	PL24A	6	LDQ28	T (LVDS)*	PL38A	6	LDQ42	T (LVDS)*	
38	VCCIO6	6			VCCIO6	6			
39	PL24B	6	LDQ28	C (LVDS)*	PL38B	6	LDQ42	C (LVDS)*	
40	VCC	-			VCC	-			
41	PL26A	6	LDQ28	T (LVDS)*	PL40A	6	LDQ42	T (LVDS)*	
42	GND	-			GND	-			
43	PL26B	6	LDQ28	C (LVDS)*	PL40B	6	LDQ42	C (LVDS)*	
44	VCCIO6	6			VCCIO6	6			
45	PL28A	6	LDQS28	T (LVDS)*	PL42A	6	LDQS42	T (LVDS)*	

LFE2-12E/SE and LFE2-20E/SE Logic Signal Connections: 208 PQFP (Cont.)

LFE2-12E/SE					LFE2-20E/SE				
Pin Number	Pin/Pad Function	Bank	Dual Function	Differential	Pin/Pad Function	Bank	Dual Function	Differential	
46	PL28B	6	LDQ28	C (LVDS)*	PL42B	6	LDQ42	C (LVDS)*	
47	PL30A	6	LDQ28		PL44A	6	LDQ42		
48	TCK	-			TCK	-			
49	TDI	-			TDI	-			
50	TDO	-			TDO	-			
51	VCCJ	-			VCCJ	-			
52	TMS	-			TMS	-			
53	PB2A	5	VREF2_5/BDQ6	T	PB2A	5	VREF2_5/BDQ6	T	
54	PB2B	5	VREF1_5/BDQ6	C	PB2B	5	VREF1_5/BDQ6	C	
55	VCCIO5	5			VCCIO5	5			
56	PB6A	5	BDQS6	T	PB6A	5	BDQS6	T	
57	PB6B	5	BDQ6	C	PB6B	5	BDQ6	C	
58	PB8A	5	BDQ6	T	PB8A	5	BDQ6	T	
59	PB8B	5	BDQ6	C	PB8B	5	BDQ6	C	
60	GND	-			GND	-			
61	PB12A	5	BDQ15	T	PB12A	5	BDQ15	T	
62	PB12B	5	BDQ15	C	PB12B	5	BDQ15	C	
63	VCCIO5	5			VCCIO5	5			
64	PB16A	5	BDQ15	T	PB16A	5	BDQ15	T	
65	PB16B	5	BDQ15	C	PB16B	5	BDQ15	C	
66	PB18A	5	BDQ15	T	PB18A	5	BDQ15	T	
67	PB18B	5	BDQ15	C	PB18B	5	BDQ15	C	
68	GND	-			GND	-			
69	PB20A	5	BDQ24	T	PB30A	5	BDQ33	T	
70	VCCAUX	-			VCCAUX	-			
71	PB20B	5	BDQ24	C	PB30B	5	BDQ33	C	
72	PB22A	5	BDQ24	T	PB32A	5	BDQ33	T	
73	PB22B	5	BDQ24	C	PB32B	5	BDQ33	C	
74	VCC	-			VCC	-			
75	PB26A	5	PCLKT5_0/BDQ24	T	PB35A	5	PCLKT5_0/BDQ33	T	
76	PB26B	5	PCLKC5_0/BDQ24	C	PB35B	5	PCLKC5_0/BDQ33	C	
77	GND	-			GND	-			
78	PB31A	4	PCLKT4_0/BDQ33	T	PB40A	4	PCLKT4_0/BDQ42	T	
79	PB31B	4	PCLKC4_0/BDQ33	C	PB40B	4	PCLKC4_0/BDQ42	C	
80	VCC	-			VCC	-			
81	GND	-			GND	-			
82	PB34A	4	BDQ33	T	PB42A	4	BDQS42	T	
83	PB34B	4	BDQ33	C	PB42B	4	BDQ42	C	
84	PB36A	4	BDQ33	T	PB44A	4	BDQ42	T	
85	PB36B	4	BDQ33	C	PB44B	4	BDQ42	C	
86	VCCAUX	-			VCCAUX	-			
87	PB40A	4	BDQ42	T	PB50A	4	BDQ51	T	
88	PB40B	4	BDQ42	C	PB50B	4	BDQ51	C	
89	GND	-			GND	-			
90	PB42A	4	BDQS42	T	PB52A	4	BDQ51	T	
91	PB42B	4	BDQ42	C	PB52B	4	BDQ51	C	

LFE2-12E/SE and LFE2-20E/SE Logic Signal Connections: 208 PQFP (Cont.)

LFE2-12E/SE					LFE2-20E/SE			
Pin Number	Pin/Pad Function	Bank	Dual Function	Differential	Pin/Pad Function	Bank	Dual Function	Differential
92	PB44A	4	BDQ42	T	PB54A	4	BDQ51	T
93	VCCIO4	4			VCCIO4	4		
94	PB44B	4	BDQ42	C	PB54B	4	BDQ51	C
95	PB48A	4	BDQ51	T	PB58A	4	BDQ60	T
96	PB48B	4	BDQ51	C	PB58B	4	BDQ60	C
97	VCC	-			VCC	-		
98	PB52A	4	BDQ51	T	PB60A	4	BDQS60	T
99	PB52B	4	BDQ51	C	PB60B	4	BDQ60	C
100	VCCIO4	4			VCCIO4	4		
101	PB54A	4	BDQ51		PB63A	4	BDQ60	
102	GND	-			GND	-		
103	PB55A	4	VREF2_4/BDQ51	T	PB64A	4	VREF2_4/BDQ60	T
104	PB55B	4	VREF1_4/BDQ51	C	PB64B	4	VREF1_4/BDQ60	C
105	CFG1	8			CFG1	8		
106	PROGRAMN	8			PROGRAMN	8		
107	CFG2	8			CFG2	8		
108	INITN	8			INITN	8		
109	CFG0	8			CFG0	8		
110	CCLK	8			CCLK	8		
111	DONE	8			DONE	8		
112	PR29A	8	D0/SPIFASTN		PR43A	8	D0/SPIFASTN	
113	VCCIO8	8			VCCIO8	8		
114	PR26A	8	D6		PR40A	8	D6	
115	GND	-			GND	-		
116	VCC	-			VCC	-		
117	PR25B	8	D7	C	PR39B	8	D7	C
118	VCCIO8	8			VCCIO8	8		
119	PR25A	8	DI/CSSPI0N	T	PR39A	8	DI/CSSPI0N	T
120	PR24B	8	DOU/CSON	C	PR38B	8	DOU/CSON	C
121	PR24A	8	BUSY/SISPI	T	PR38A	8	BUSY/SISPI	T
122	GND	-			GND	-		
123	VCCIO3	3			VCCIO3	3		
124	PR21A	3	RLM0_GPLLT_FB_A		PR31A	3	RLM0_GPLLT_FB_A/RDQ34	
125	VCCAUX	-			VCCAUX	-		
126	PR20B	3	RLM0_GPLLC_IN_A**	C (LVDS)*	PR30B	3	RLM0_GPLLC_IN_A**/RDQ34	C (LVDS)*
127	PR20A	3	RLM0_GPLLT_IN_A**	T (LVDS)*	PR30A	3	RLM0_GPLLT_IN_A**/RDQ34	T (LVDS)*
128	RLM0_PLLCAP	3			RLM0_PLLCAP	3		
129	VCC	-			VCC	-		
130	PR18B	3	RLM0_GDLLC_FB_A	C	PR28B	3	RLM0_GDLLC_FB_A/RDQ25	C
131	PR18A	3	RLM0_GDLLT_FB_A	T	PR28A	3	RLM0_GDLLT_FB_A**/RDQ25	T
132	PR17B	3	RLM0_GDLLC_IN_A**	C (LVDS)*	PR27B	3	RLM0_GDLLC_IN_A/RDQ25	C (LVDS)*
133	PR17A	3	RLM0_GDLLT_IN_A**	T (LVDS)*	PR27A	3	RLM0_GDLLT_IN_A**/RDQ25	T (LVDS)*
134	PR16B	3	VREF2_3	C	PR22B	3	VREF2_3/RDQ25	C
135	VCCIO3	3			VCCIO3	3		
136	PR16A	3	VREF1_3	T	PR22A	3	VREF1_3/RDQ25	T
137	PR15B	3	PCLKC3_0	C (LVDS)*	PR21B	3	PCLKC3_0/RDQ25	C (LVDS)*

LFE2-12E/SE and LFE2-20E/SE Logic Signal Connections: 208 PQFP (Cont.)

LFE2-12E/SE					LFE2-20E/SE				
Pin Number	Pin/Pad Function	Bank	Dual Function	Differential	Pin/Pad Function	Bank	Dual Function	Differential	
138	PR15A	3	PCLKT3_0	T (LVDS)*	PR21A	3	PCLKT3_0/RDQ25	T (LVDS)*	
139	GND	-			GND	-			
140	VCC	-			VCC	-			
141	PR13B	2	PCLKC2_0/RDQ10	C	PR19B	2	PCLKC2_0/RDQ16	C	
142	PR13A	2	PCLKT2_0/RDQ10	T	PR19A	2	PCLKT2_0/RDQ16	T	
143	VCCIO2	2			VCCIO2	2			
144	PR12A	2	RDQ10		PR16A	2	RDQS16		
145	GND	-			GND	-			
146	VCC	-			VCC	-			
147	PR8B	2	RDQ10	C (LVDS)*	PR14B	2	RDQ16	C (LVDS)*	
148	VCCIO2	2			VCCIO2	2			
149	PR8A	2	RDQ10	T (LVDS)*	PR14A	2	RDQ16	T (LVDS)*	
150	PR6B	2	RDQ10	C (LVDS)*	PR12B	2	RDQ16	C (LVDS)*	
151	VCCAUX	-			VCCAUX	-			
152	PR6A	2	RDQ10	T (LVDS)*	PR12A	2	RDQ16	T (LVDS)*	
153	PR4B	2		C (LVDS)*	PR6B	2	RDQ8	C (LVDS)*	
154	PR4A	2		T (LVDS)*	PR6A	2	RDQ8	T (LVDS)*	
155	PR2B	2	VREF2_2	C (LVDS)*	PR2B	2	VREF2_2	C (LVDS)*	
156	PR2A	2	VREF1_2	T (LVDS)*	PR2A	2	VREF1_2	T (LVDS)*	
157	PT55B	1	VREF2_1	C	PT64B	1	VREF2_1	C	
158	PT55A	1	VREF1_1	T	PT64A	1	VREF1_1	T	
159	GND	-			GND	-			
160	PT54B	1		C	PT62B	1		C	
161	PT54A	1		T	PT62A	1		T	
162	VCCIO1	1			VCCIO1	1			
163	PT52B	1		C	PT60B	1		C	
164	PT52A	1		T	PT60A	1		T	
165	PT50B	1		C	PT58B	1		C	
166	PT50A	1		T	PT58A	1		T	
167	PT48B	1		C	PT56B	1		C	
168	PT48A	1		T	PT56A	1		T	
169	GND	-			GND	-			
170	VCCIO1	1			VCCIO1	1			
171	VCC	-			VCC	-			
172	PT40B	1		C	PT50B	1		C	
173	PT40A	1		T	PT50A	1		T	
174	VCCAUX	-			VCCAUX	-			
175	GND	-			GND	-			
176	PT36B	1		C	PT44B	1		C	
177	PT36A	1		T	PT44A	1		T	
178	PT34B	1		C	PT42B	1		C	
179	PT34A	1		T	PT42A	1		T	
180	PT30B	1	PCLKC1_0	C	PT39B	1	PCLKC1_0	C	
181	PT30A	1	PCLKT1_0	T	PT39A	1	PCLKT1_0	T	
182	XRES	1			XRES	1			
183	PT28B	0	PCLKC0_0	C	PT37B	0	PCLKC0_0	C	

LFE2-12E/SE and LFE2-20E/SE Logic Signal Connections: 208 PQFP (Cont.)

LFE2-12E/SE					LFE2-20E/SE				
Pin Number	Pin/Pad Function	Bank	Dual Function	Differential	Pin/Pad Function	Bank	Dual Function	Differential	
184	GND	-			GND	-			
185	PT28A	0	PCLKT0_0	T	PT37A	0	PCLKT0_0	T	
186	PT26B	0		C	PT36B	0		C	
187	PT26A	0		T	PT36A	0		T	
188	VCC	-			VCC	-			
189	PT20B	0		C	PT30B	0		C	
190	VCCAUX	-			VCCAUX	-			
191	PT20A	0		T	PT30A	0		T	
192	GND	-			GND	-			
193	PT18B	0		C	PT26B	0		C	
194	PT18A	0		T	PT26A	0		T	
195	VCCIO0	0			VCCIO0	0			
196	PT16B	0		C	PT20B	0		C	
197	PT16A	0		T	PT20A	0		T	
198	VCC	-			VCC	-			
199	PT12B	0		C	PT12B	0		C	
200	PT12A	0		T	PT12A	0		T	
201	GND	-			GND	-			
202	PT8B	0		C	PT8B	0		C	
203	PT8A	0		T	PT8A	0		T	
204	PT6B	0		C	PT6B	0		C	
205	PT6A	0		T	PT6A	0		T	
206	VCCIO0	0			VCCIO0	0			
207	PT2B	0	VREF2_0	C	PT2B	0	VREF2_0	C	
208	PT2A	0	VREF1_0	T	PT2A	0	VREF1_0	T	

* Supports true LVDS. Other differential signals must be emulated with external resistors.

** These dedicated input pins can be used for GPLLs or GDLLs within the respective quadrant.

Note: VCCIO and GND pads are used to determine the average DC current drawn by I/Os between GND/VCCIO connections, or between the last GND/VCCIO in an I/O bank and the end of an I/O bank. The substrate pads listed in the Pin Table do not necessarily have a one to one connection with a package ball or pin.

LFE2-6E/SE and LFE2-12E/SE Logic Signal Connections: 256 fpBGA

LFE2-6E/SE					LFE2-12E/SE			
Ball Number	Ball/Pad Function	Bank	Dual Function	Differential	Ball/Pad Function	Bank	Dual Function	Differential
C3	PL2A	7	VREF2_7	T (LVDS)*	PL2A	7	VREF2_7	T (LVDS)*
C2	PL2B	7	VREF1_7	C (LVDS)*	PL2B	7	VREF1_7	C (LVDS)*
VCCIO	VCCIO7	7			VCCIO7	7		
-	-	-			-	-		
D3	PL5A	7		T	PL5A	7		T
D4	PL4A	7		T (LVDS)*	PL4A	7		T (LVDS)*
D2	PL5B	7		C	PL5B	7		C
GND	GNDIO7	-			GNDIO7	-		
E4	PL4B	7		C (LVDS)*	PL4B	7		C (LVDS)*
B1	PL7A	7	LDQ10	T	PL7A	7	LDQ10	T
C1	PL7B	7	LDQ10	C	PL7B	7	LDQ10	C
F5	PL9A	7	LDQ10	T	PL9A	7	LDQ10	T
VCCIO	VCCIO7	7			VCCIO7	7		
F4	PL8A	7	LDQ10	T (LVDS)*	PL8A	7	LDQ10	T (LVDS)*
G6	PL9B	7	LDQ10	C	PL9B	7	LDQ10	C
G4	PL8B	7	LDQ10	C (LVDS)*	PL8B	7	LDQ10	C (LVDS)*
D1	PL10A	7	LDQS10	T (LVDS)*	PL10A	7	LDQS10	T (LVDS)*
GND	GNDIO7	-			GNDIO7	-		
E1	PL10B	7	LDQ10	C (LVDS)*	PL10B	7	LDQ10	C (LVDS)*
F3	PL11A	7	LDQ10	T	PL11A	7	LDQ10	T
G3	PL11B	7	LDQ10	C	PL11B	7	LDQ10	C
VCCIO	VCCIO7	7			VCCIO7	7		
F2	PL12A	7	LDQ10	T (LVDS)*	PL12A	7	LDQ10	T (LVDS)*
F1	PL12B	7	LDQ10	C (LVDS)*	PL12B	7	LDQ10	C (LVDS)*
GND	GNDIO7	-			GNDIO7	-		
G2	PL13A	7	PCLKT7_0/LDQ10	T	PL13A	7	PCLKT7_0/LDQ10	T
G1	PL13B	7	PCLKC7_0/LDQ10	C	PL13B	7	PCLKC7_0/LDQ10	C
H6	PL15A	6	PCLKT6_0	T (LVDS)*	PL15A	6	PCLKT6_0	T (LVDS)*
VCCIO	VCCIO6	6			VCCIO6	6		
H5	PL15B	6	PCLKC6_0	C (LVDS)*	PL15B	6	PCLKC6_0	C (LVDS)*
H4	PL16A	6	VREF2_6	T	PL16A	6	VREF2_6	T
GND	GNDIO6	-			GNDIO6	-		
H3	PL16B	6	VREF1_6	C	PL16B	6	VREF1_6	C
H2	PL17A	6	LLM0_GDLLT_IN_A**	T (LVDS)*	PL17A	6	LLM0_GDLLT_IN_A**	T (LVDS)*
H1	PL17B	6	LLM0_GDLLC_IN_A**	C (LVDS)*	PL17B	6	LLM0_GDLLC_IN_A**	C (LVDS)*
G10	VCC	-			VCC	-		
J4	PL18A	6	LLM0_GDLLT_FB_A	T	PL18A	6	LLM0_GDLLT_FB_A	T
J5	PL18B	6	LLM0_GDLLC_FB_A	C	PL18B	6	LLM0_GDLLC_FB_A	C
J6	LLM0_PLLCAP	6			LLM0_PLLCAP	6		
K4	PL20A	6	LLM0_GPLLT_IN_A**	T (LVDS)*	PL20A	6	LLM0_GPLLT_IN_A**	T (LVDS)*
GND	GNDIO6	-			GNDIO6	-		
J1	PL21A	6	LLM0_GPLLT_FB_A	T	PL21A	6	LLM0_GPLLT_FB_A	T
K3	PL20B	6	LLM0_GPLLC_IN_A**	C (LVDS)*	PL20B	6	LLM0_GPLLC_IN_A**	C (LVDS)*
VCCIO	VCCIO6	6			VCCIO6	6		
J2	PL21B	6	LLM0_GPLLC_FB_A	C	PL21B	6	LLM0_GPLLC_FB_A	C

LFE2-6E/SE and LFE2-12E/SE Logic Signal Connections: 256 fpBGA (Cont.)

LFE2-6E/SE					LFE2-12E/SE			
Ball Number	Ball/Pad Function	Bank	Dual Function	Differential	Ball/Pad Function	Bank	Dual Function	Differential
GND	GNDIO6	-			GNDIO6	-		
L2	PL24A	6	LDQ28	T (LVDS)*	PL24A	6	LDQ28	T (LVDS)*
K2	PL25A	6	LDQ28	T	PL25A	6	LDQ28	T
L3	PL24B	6	LDQ28	C (LVDS)*	PL24B	6	LDQ28	C (LVDS)*
K1	PL25B	6	LDQ28	C	PL25B	6	LDQ28	C
VCCIO	VCCIO6	6			VCCIO6	6		
L4	PL26A	6	LDQ28	T (LVDS)*	PL26A	6	LDQ28	T (LVDS)*
L1	PL27A	6	LDQ28	T	PL27A	6	LDQ28	T
L5	PL26B	6	LDQ28	C (LVDS)*	PL26B	6	LDQ28	C (LVDS)*
M1	PL27B	6	LDQ28	C	PL27B	6	LDQ28	C
GND	GNDIO6	-			GNDIO6	-		
N1	PL29A	6	LDQ28	T	PL29A	6	LDQ28	T
N2	PL28A	6	LDQS28	T (LVDS)*	PL28A	6	LDQS28	T (LVDS)*
P1	PL29B	6	LDQ28	C	PL29B	6	LDQ28	C
VCCIO	VCCIO6	6			VCCIO6	6		
P2	PL28B	6	LDQ28	C (LVDS)*	PL28B	6	LDQ28	C (LVDS)*
R1	PL30A	6	LDQ28	T (LVDS)*	PL30A	6	LDQ28	T (LVDS)*
GND	GNDIO6	-			GNDIO6	-		
R2	PL30B	6	LDQ28	C (LVDS)*	PL30B	6	LDQ28	C (LVDS)*
N4	TDI	-			TDI	-		
M4	TCK	-			TCK	-		
P3	TDO	-			TDO	-		
N3	TMS	-			TMS	-		
K7	VCCJ	-			VCCJ	-		
M5	PB2A	5	VREF2_5/BDQ6	T	PB2A	5	VREF2_5/BDQ6	T
K6	NC	-			PB3A	5	BDQ6	
M6	PB2B	5	VREF1_5/BDQ6	C	PB2B	5	VREF1_5/BDQ6	C
R3	NC	-			PB5A	5	BDQ6	T
P4	NC	-			PB5B	5	BDQ6	C
-	-	-			VCCIO	5		
-	-	-			GNDIO5	5		
N5	PB3A	5	BDQ6	T	PB21A	5	BDQ24	T
N6	PB3B	5	BDQ6	C	PB21B	5	BDQ24	C
T2	PB4A	5	BDQ6	T	PB22A	5	BDQ24	T
P6	PB5A	5	BDQ6	T	PB23A	5	BDQ24	T
VCCIO	VCCIO5	5			VCCIO5	5		
T3	PB4B	5	BDQ6	C	PB22B	5	BDQ24	C
R6	PB5B	5	BDQ6	C	PB23B	5	BDQ24	C
GND	GNDIO5	-			GNDIO5	-		
R4	PB6A	5	BDQS6	T	PB24A	5	BDQS24	T
L6	PB7A	5	BDQ6	T	PB25A	5	BDQ24	T
T4	PB6B	5	BDQ6	C	PB24B	5	BDQ24	C
L7	PB7B	5	BDQ6	C	PB25B	5	BDQ24	C
N7	PB8A	5	PCLKT5_0/BDQ6	T	PB26A	5	PCLKT5_0/BDQ24	T
VCCIO	VCCIO5	5			VCCIO5	5		

LFE2-6E/SE and LFE2-12E/SE Logic Signal Connections: 256 fpBGA (Cont.)

LFE2-6E/SE					LFE2-12E/SE			
Ball Number	Ball/Pad Function	Bank	Dual Function	Differential	Ball/Pad Function	Bank	Dual Function	Differential
M8	PB8B	5	PCLKC5_0/BDQ6	C	PB26B	5	PCLKC5_0/BDQ24	C
GND	GNDIO5	-			GNDIO5	-		
P7	PB13A	4	PCLKT4_0/BDQ15	T	PB31A	4	PCLKT4_0/BDQ33	T
R8	PB13B	4	PCLKC4_0/BDQ15	C	PB31B	4	PCLKC4_0/BDQ33	C
VCCIO	VCCIO4	4			VCCIO4	4		
T5	PB14A	4	BDQ15	T	PB32A	4	BDQ33	T
T6	PB14B	4	BDQ15	C	PB32B	4	BDQ33	C
T8	PB15A	4	BDQS15	T	PB33A	4	BDQS33	T
GND	GNDIO4	-			GNDIO4	-		
R7	PB16A	4	BDQ15	T	PB34A	4	BDQ33	T
T9	PB15B	4	BDQ15	C	PB33B	4	BDQ33	C
T7	PB16B	4	BDQ15	C	PB34B	4	BDQ33	C
L8	PB17A	4	BDQ15	T	PB35A	4	BDQ33	T
VCCIO	VCCIO4	4			VCCIO4	4		
P8	PB18A	4	BDQ15	T	PB36A	4	BDQ33	T
L9	PB17B	4	BDQ15	C	PB35B	4	BDQ33	C
N8	PB18B	4	BDQ15	C	PB36B	4	BDQ33	C
R9	PB19A	4	BDQ15	T	PB37A	4	BDQ33	T
GND	GNDIO4	-			GNDIO4	-		
R10	PB19B	4	BDQ15	C	PB37B	4	BDQ33	C
-	-	-			VCCIO	4		
-	-	-			GNDIO4	4		
N9	PB20A	4	BDQ24	T	PB47A	4	BDQ51	T
T10	PB21A	4	BDQ24	T	PB48A	4	BDQ51	T
M9	PB20B	4	BDQ24	C	PB47B	4	BDQ51	C
R11	PB21B	4	BDQ24	C	PB48B	4	BDQ51	C
P10	PB22A	4	BDQ24	T	PB49A	4	BDQ51	T
N11	PB23A	4	BDQ24	T	PB50A	4	BDQ51	T
VCCIO	VCCIO4	4			VCCIO4	4		
N10	PB22B	4	BDQ24	C	PB49B	4	BDQ51	C
P11	PB23B	4	BDQ24	C	PB50B	4	BDQ51	C
T11	PB24A	4	BDQS24	T	PB51A	4	BDQS51	T
GND	GNDIO4	-			GNDIO4	-		
M11	PB25A	4	BDQ24	T	PB52A	4	BDQ51	T
T12	PB24B	4	BDQ24	C	PB51B	4	BDQ51	C
L11	PB25B	4	BDQ24	C	PB52B	4	BDQ51	C
T13	PB26A	4	BDQ24	T	PB53A	4	BDQ51	T
R13	PB27A	4	BDQ24	T	PB54A	4	BDQ51	T
VCCIO	VCCIO4	4			VCCIO4	4		
T14	PB26B	4	BDQ24	C	PB53B	4	BDQ51	C
P13	PB27B	4	BDQ24	C	PB54B	4	BDQ51	C
GND	GNDIO4	-			GNDIO4	-		
N12	PB28A	4	VREF2_4/BDQ24	T	PB55A	4	VREF2_4/BDQ51	T
M12	PB28B	4	VREF1_4/BDQ24	C	PB55B	4	VREF1_4/BDQ51	C
R15	CFG2	8			CFG2	8		

LFE2-6E/SE and LFE2-12E/SE Logic Signal Connections: 256 fpBGA (Cont.)

LFE2-6E/SE					LFE2-12E/SE			
Ball Number	Ball/Pad Function	Bank	Dual Function	Differential	Ball/Pad Function	Bank	Dual Function	Differential
N14	CFG1	8			CFG1	8		
N13	PROGRAMN	8			PROGRAMN	8		
N15	CFG0	8			CFG0	8		
P15	PR30B	8	WRITEN	C	PR30B	8	WRITEN	C
L12	INITN	8			INITN	8		
N16	PR29B	8	CSN	C	PR29B	8	CSN	C
GND	GNDIO8	-			GNDIO8	-		
R14	CCLK	8			CCLK	8		
P14	PR30A	8	CS1N	T	PR30A	8	CS1N	T
M13	DONE	8			DONE	8		
R16	PR28B	8	D1	C	PR28B	8	D1	C
VCCIO	VCCIO8	8			VCCIO8	8		
M16	PR29A	8	D0/SPIFASTN	T	PR29A	8	D0/SPIFASTN	T
P16	PR28A	8	D2	T	PR28A	8	D2	T
L15	PR27B	8	D3	C	PR27B	8	D3	C
GND	GNDIO8	-			GNDIO8	-		
L14	PR26A	8	D6	T	PR26A	8	D6	T
L16	PR27A	8	D4	T	PR27A	8	D4	T
L10	PR25B	8	D7	C	PR25B	8	D7	C
L13	PR26B	8	D5	C	PR26B	8	D5	C
VCCIO	VCCIO8	8			VCCIO8	8		
K11	PR25A	8	DI/CSSPI0N	T	PR25A	8	DI/CSSPI0N	T
K14	PR24B	8	DOUT/CSON	C	PR24B	8	DOUT/CSON	C
K13	PR24A	8	BUSY/SISPI	T	PR24A	8	BUSY/SISPI	T
GND	GNDIO8	-			GNDIO8	-		
K15	PR21B	3	RLM0_GPLL_C_FB_A	C	PR21B	3	RLM0_GPLL_C_FB_A	C
VCCIO	VCCIO3	3			VCCIO3	3		
K16	PR21A	3	RLM0_GPLL_T_FB_A	T	PR21A	3	RLM0_GPLL_T_FB_A	T
GND	GNDIO3	-			GNDIO3	-		
J16	PR20B	3	RLM0_GPLL_C_IN_A**	C (LVDS)*	PR20B	3	RLM0_GPLL_C_IN_A**	C (LVDS)*
J15	PR20A	3	RLM0_GPLL_T_IN_A**	T (LVDS)*	PR20A	3	RLM0_GPLL_T_IN_A**	T (LVDS)*
J14	RLM0_PLLCAP	3			RLM0_PLLCAP	3		
J13	PR18B	3	RLM0_GDLL_C_FB_A	C	PR18B	3	RLM0_GDLL_C_FB_A	C
J12	PR18A	3	RLM0_GDLL_T_FB_A	T	PR18A	3	RLM0_GDLL_T_FB_A	T
H12	PR17B	3	RLM0_GDLL_C_IN_A**	C (LVDS)*	PR17B	3	RLM0_GDLL_C_IN_A**	C (LVDS)*
GND	GNDIO3	-			GNDIO3	-		
H13	PR17A	3	RLM0_GDLL_T_IN_A**	T (LVDS)*	PR17A	3	RLM0_GDLL_T_IN_A**	T (LVDS)*
H15	PR16B	3	VREF2_3	C	PR16B	3	VREF2_3	C
VCCIO	VCCIO3	3			VCCIO3	3		
H16	PR16A	3	VREF1_3	T	PR16A	3	VREF1_3	T
H11	PR15B	3	PCLKC3_0	C (LVDS)*	PR15B	3	PCLKC3_0	C (LVDS)*
J11	PR15A	3	PCLKT3_0	T (LVDS)*	PR15A	3	PCLKT3_0	T (LVDS)*
G16	PR13B	2	PCLKC2_0/RDQ10	C	PR13B	2	PCLKC2_0/RDQ10	C
GND	GNDIO2	-			GNDIO2	-		
G15	PR13A	2	PCLKT2_0/RDQ10	T	PR13A	2	PCLKT2_0/RDQ10	T

LFE2-6E/SE and LFE2-12E/SE Logic Signal Connections: 256 fpBGA (Cont.)

LFE2-6E/SE					LFE2-12E/SE			
Ball Number	Ball/Pad Function	Bank	Dual Function	Differential	Ball/Pad Function	Bank	Dual Function	Differential
F15	PR11B	2	RDQ10	C	PR11B	2	RDQ10	C
G11	PR12B	2	RDQ10	C (LVDS)*	PR12B	2	RDQ10	C (LVDS)*
F14	PR11A	2	RDQ10	T	PR11A	2	RDQ10	T
VCCIO	VCCIO2	2			VCCIO2	2		
F12	PR12A	2	RDQ10	T (LVDS)*	PR12A	2	RDQ10	T (LVDS)*
G14	PR10B	2	RDQ10	C (LVDS)*	PR10B	2	RDQ10	C (LVDS)*
G13	PR10A	2	RDQS10	T (LVDS)*	PR10A	2	RDQS10	T (LVDS)*
GND	GNDIO2	-			GNDIO2	-		
F16	PR8B	2	RDQ10	C (LVDS)*	PR8B	2	RDQ10	C (LVDS)*
F9	PR9B	2	RDQ10	C	PR9B	2	RDQ10	C
E16	PR8A	2	RDQ10	T (LVDS)*	PR8A	2	RDQ10	T (LVDS)*
F10	PR9A	2	RDQ10	T	PR9A	2	RDQ10	T
VCCIO	VCCIO2	2			VCCIO2	2		
D16	PR7B	2	RDQ10	C	PR7B	2	RDQ10	C
D15	PR7A	2	RDQ10	T	PR7A	2	RDQ10	T
C15	PR4B	2		C (LVDS)*	PR4B	2		C (LVDS)*
C16	PR5B	2		C	PR5B	2		C
GND	GNDIO2	-			GNDIO2	-		
D14	PR4A	2		T (LVDS)*	PR4A	2		T (LVDS)*
B16	PR5A	2		T	PR5A	2		T
F13	PR2B	2	VREF2_2	C (LVDS)*	PR2B	2	VREF2_2	C (LVDS)*
VCCIO	VCCIO2	2			VCCIO2	2		
E13	PR2A	2	VREF1_2	T (LVDS)*	PR2A	2	VREF1_2	T (LVDS)*
F11	PT28B	1	VREF2_1	C	PT55B	1	VREF2_1	C
E11	PT28A	1	VREF1_1	T	PT55A	1	VREF1_1	T
GND	GNDIO1	-			GNDIO1	-		
A15	PT27B	1		C	PT54B	1		C
E12	PT26B	1		C	PT53B	1		C
B15	PT27A	1		T	PT54A	1		T
VCCIO	VCCIO1	1			VCCIO1	1		
D12	PT26A	1		T	PT53A	1		T
B14	PT25B	1		C	PT52B	1		C
C14	PT24B	1		C	PT51B	1		C
A14	PT25A	1		T	PT52A	1		T
D13	PT24A	1		T	PT51A	1		T
C13	PT23B	1		C	PT50B	1		C
GND	GNDIO1	-			GNDIO1	-		
A13	PT22B	1		C	PT49B	1		C
B13	PT23A	1		T	PT50A	1		T
VCCIO	VCCIO1	1			VCCIO1	1		
A12	PT22A	1		T	PT49A	1		T
B11	PT21B	1		C	PT48B	1		C
D11	PT20B	1		C	PT47B	1		C
A11	PT21A	1		T	PT48A	1		T
C11	PT20A	1		T	PT47A	1		T

LFE2-6E/SE and LFE2-12E/SE Logic Signal Connections: 256 fpBGA (Cont.)

LFE2-6E/SE					LFE2-12E/SE			
Ball Number	Ball/Pad Function	Bank	Dual Function	Differential	Ball/Pad Function	Bank	Dual Function	Differential
-	-	-			GNDIO1	1		
-	-	-			VCCIO	1		
D10	PT19B	1		C	PT37B	1		C
C10	PT19A	1		T	PT37A	1		T
GND	GNDIO1	-			GNDIO1	-		
B10	PT18B	1		C	PT36B	1		C
A9	PT17B	1		C	PT35B	1		C
A10	PT18A	1		T	PT36A	1		T
B9	PT17A	1		T	PT35A	1		T
VCCIO	VCCIO1	1			VCCIO1	1		
A8	PT16B	1		C	PT34B	1		C
D9	PT15B	1		C	PT33B	1		C
B8	PT16A	1		T	PT34A	1		T
C9	PT15A	1		T	PT33A	1		T
GND	GNDIO1	-			GNDIO1	-		
B7	PT14B	1		C	PT32B	1		C
E9	PT13B	1		C	PT31B	1		C
A7	PT14A	1		T	PT32A	1		T
D8	PT13A	1		T	PT31A	1		T
VCCIO	VCCIO1	1			VCCIO1	1		
A6	PT12B	1	PCLKC1_0	C	PT30B	1	PCLKC1_0	C
B6	PT12A	1	PCLKT1_0	T	PT30A	1	PCLKT1_0	T
E6	XRES	-			XRES	1		
F8	PT10B	0	PCLKC0_0	C	PT28B	0	PCLKC0_0	C
GND	GNDIO0	-			GNDIO0	-		
E8	PT10A	0	PCLKT0_0	T	PT28A	0	PCLKT0_0	T
A5	PT9B	0		C	PT27B	0		C
A3	PT8B	0		C	PT26B	0		C
A4	PT9A	0		T	PT27A	0		T
VCCIO	VCCIO0	0			VCCIO0	0		
B3	PT8A	0		T	PT26A	0		T
A2	PT7B	0		C	PT25B	0		C
C7	PT6B	0		C	PT24B	0		C
B2	PT7A	0		T	PT25A	0		T
D7	PT6A	0		T	PT24A	0		T
D6	PT5B	0		C	PT23B	0		C
GND	GNDIO0	-			GNDIO0	-		
F7	PT4B	0		C	PT22B	0		C
C6	PT5A	0		T	PT23A	0		T
VCCIO	VCCIO0	0			VCCIO0	0		
F6	PT4A	0		T	PT22A	0		T
C4	PT3B	0		C	PT21B	0		C
B4	PT3A	0		T	PT21A	0		T
-	-	-			GNDIO0	0		
-	-	-			VCCIO	0		

LFE2-6E/SE and LFE2-12E/SE Logic Signal Connections: 256 fpBGA (Cont.)

LFE2-6E/SE					LFE2-12E/SE			
Ball Number	Ball/Pad Function	Bank	Dual Function	Differential	Ball/Pad Function	Bank	Dual Function	Differential
D5	PT2B	0	VREF2_0	C	PT2B	0	VREF2_0	C
E5	PT2A	0	VREF1_0	T	PT2A	0	VREF1_0	T
G7	VCC	-			VCC	-		
G9	VCC	-			VCC	-		
H7	VCC	-			VCC	-		
J10	VCC	-			VCC	-		
K10	VCC	-			VCC	-		
K8	VCC	-			VCC	-		
G8	VCCAUX	-			VCCAUX	-		
H10	VCCAUX	-			VCCAUX	-		
J7	VCCAUX	-			VCCAUX	-		
K9	VCCAUX	-			VCCAUX	-		
C5	VCCIO0	0			VCCIO0	0		
E7	VCCIO0	0			VCCIO0	0		
C12	VCCIO1	1			VCCIO1	1		
E10	VCCIO1	1			VCCIO1	1		
E14	VCCIO2	2			VCCIO2	2		
G12	VCCIO2	2			VCCIO2	2		
K12	VCCIO3	3			VCCIO3	3		
M14	VCCIO3	3			VCCIO3	3		
M10	VCCIO4	4			VCCIO4	4		
P12	VCCIO4	4			VCCIO4	4		
M7	VCCIO5	5			VCCIO5	5		
P5	VCCIO5	5			VCCIO5	5		
K5	VCCIO6	6			VCCIO6	6		
M3	VCCIO6	6			VCCIO6	6		
E3	VCCIO7	7			VCCIO7	7		
G5	VCCIO7	7			VCCIO7	7		
T15	VCCIO8	8			VCCIO8	8		
A1	GND	-			GND	-		
A16	GND	-			GND	-		
B12	GND	-			GND	-		
B5	GND	-			GND	-		
C8	GND	-			GND	-		
E15	GND	-			GND	-		
E2	GND	-			GND	-		
H14	GND	-			GND	-		
H8	GND	-			GND	-		
H9	GND	-			GND	-		
J3	GND	-			GND	-		
J8	GND	-			GND	-		
J9	GND	-			GND	-		
M15	GND	-			GND	-		
M2	GND	-			GND	-		
P9	GND	-			GND	-		

LFE2-6E/SE and LFE2-12E/SE Logic Signal Connections: 256 fpBGA (Cont.)

LFE2-6E/SE					LFE2-12E/SE			
Ball Number	Ball/Pad Function	Bank	Dual Function	Differential	Ball/Pad Function	Bank	Dual Function	Differential
R12	GND	-			GND	-		
R5	GND	-			GND	-		
T1	GND	-			GND	-		
T16	GND	-			GND	-		

* Supports true LVDS. Other differential signals must be emulated with external resistors.

** These dedicated input pins can be used for GPLLs or GDLLs within the respective quadrant.

Note: VCCIO and GND pads are used to determine the average DC current drawn by I/Os between GND/VCCIO connections, or between the last GND/VCCIO in an I/O bank and the end of an I/O bank. The substrate pads listed in the Pin Table do not necessarily have a one to one connection with a package ball or pin.

LFE2-20E/SE Logic Signal Connections: 256 fpBGA

LFE2-20E/SE					
Ball Number	Ball Number	Ball/Pad Function	Bank	Dual Function	Differential
C3	C3	PL2A	7	VREF2_7	T (LVDS)*
C2	C2	PL2B	7	VREF1_7	C (LVDS)*
VCCIO	VCCIO	VCCIO7	7		
-	GND	GNDIO7	7		
D3	D3	PL7A	7	LDQ8	T
D4	D4	PL6A	7	LDQ8	T (LVDS)*
D2	D2	PL7B	7	LDQ8	C
GND	GND	GNDIO7	-		
E4	E4	PL6B	7	LDQ8	C (LVDS)*
B1	B1	PL13A	7	LDQ16	T
C1	C1	PL13B	7	LDQ16	C
F5	F5	PL15A	7	LDQ16	T
VCCIO	VCC	VCCIO	7		
F4	F4	PL14A	7	LDQ16	T (LVDS)*
G6	G6	PL15B	7	LDQ16	C
G4	G4	PL14B	7	LDQ16	C (LVDS)*
D1	D1	PL16A	7	LDQS16	T (LVDS)*
GND	GND	GNDIO7	-		
E1	E1	PL16B	7	LDQ16	C (LVDS)*
F3	F3	PL17A	7	LDQ16	T
G3	G3	PL17B	7	LDQ16	C
VCCIO	VCCIO	VCCIO7	7		
F2	F2	PL18A	7	LDQ16	T (LVDS)*
F1	F1	PL18B	7	LDQ16	C (LVDS)*
GND	GND	GNDIO7	-		
G2	G2	PL19A	7	PCLKT7_0/LDQ16	T
G1	G1	PL19B	7	PCLKC7_0/LDQ16	C
H6	H6	PL21A	6	PCLKT6_0/LDQ25	T (LVDS)*
VCCIO	VCCIO	VCCIO6	6		
H5	H5	PL21B	6	PCLKC6_0/LDQ25	C (LVDS)*
H4	H4	PL22A	6	VREF2_6/LDQ25	T
GND	GND	GNDIO6	-		
H3	H3	PL22B	6	VREF1_6/LDQ25	C
H2	H2	PL27A	6	LLM0_GDLLT_IN_A**/LDQ25	T (LVDS)*
H1	H1	PL27B	6	LLM0_GDLLC_IN_A**/LDQ25	C (LVDS)*
G10	G10	VCC	-		
J4	J4	PL28A	6	LLM0_GDLLT_FB_A/LDQ25	T
J5	J5	PL28B	6	LLM0_GDLLC_FB_A/LDQ25	C
J6	J6	LLM0_PLLCAP	6		
K4	K4	PL30A	6	LLM0_GPLLT_IN_A**/LDQ34	T (LVDS)*
GND	GND	GNDIO6	-		

LFE2-20E/SE Logic Signal Connections: 256 fpBGA (Cont.)

LFE2-20E/SE					
Ball Number	Ball Number	Ball/Pad Function	Bank	Dual Function	Differential
J1	J1	PL31A	6	LLM0_GPLLT_FB_A/LDQ34	T
K3	K3	PL30B	6	LLM0_GPLLC_IN_A**/LDQ34	C (LVDS)*
VCCIO	VCCIO	VCCIO6	6		
J2	J2	PL31B	6	LLM0_GPLLC_FB_A/LDQ34	C
GND	GND	GNDIO6	-		
L2	L2	PL38A	6	LDQ42	T (LVDS)*
K2	K2	PL39A	6	LDQ42	T
L3	L3	PL38B	6	LDQ42	C (LVDS)*
K1	K1	PL39B	6	LDQ42	C
VCCIO	VCCIO	VCCIO6	6		
L4	L4	PL40A	6	LDQ42	T (LVDS)*
L1	L1	PL41A	6	LDQ42	T
L5	L5	PL40B	6	LDQ42	C (LVDS)*
M1	M1	PL41B	6	LDQ42	C
GND	GND	GNDIO6	-		
N1	N1	PL43A	6	LDQ42	T
N2	N2	PL42A	6	LDQS42	T (LVDS)*
P1	P1	PL43B	6	LDQ42	C
VCCIO	VCCIO	VCCIO6	6		
P2	P2	PL42B	6	LDQ42	C (LVDS)*
R1	R1	PL44A	6	LDQ42	T (LVDS)*
GND	GND	GNDIO6	-		
R2	R2	PL44B	6	LDQ42	C (LVDS)*
N4	N4	TDI	-		
M4	M4	TCK	-		
P3	P3	TDO	-		
N3	N3	TMS	-		
K7	K7	VCCJ	-		
M5	M5	PB2A	5	VREF2_5/BDQ6	T
K6	K6	PB3A	5	BDQ6	
M6	M6	PB2B	5	VREF1_5/BDQ6	C
R3	R3	PB5A	5	BDQ6	T
P4	P4	PB5B	5	BDQ6	C
-	VCC	VCCIO	5		
-	GND	GNDIO5	5		
N5	N5	PB30A	5	BDQ33	T
N6	N6	PB30B	5	BDQ33	C
T2	T2	PB31A	5	BDQ33	T
P6	P6	PB32A	5	BDQ33	T
VCCIO	VCCIO	VCCIO5	5		
T3	T3	PB31B	5	BDQ33	C
R6	R6	PB32B	5	BDQ33	C

LFE2-20E/SE Logic Signal Connections: 256 fpBGA (Cont.)

LFE2-20E/SE					
Ball Number	Ball Number	Ball/Pad Function	Bank	Dual Function	Differential
GND	GND	GNDIO5	-		
R4	R4	PB33A	5	BDQS33	T
L6	L6	PB34A	5	BDQ33	T
T4	T4	PB33B	5	BDQ33	C
L7	L7	PB34B	5	BDQ33	C
N7	N7	PB35A	5	PCLKT5_0/BDQ33	T
VCCIO	VCCIO	VCCIO5	5		
M8	M8	PB35B	5	PCLKC5_0/BDQ33	C
GND	GND	GNDIO5	-		
P7	P7	PB40A	4	PCLKT4_0/BDQ42	T
R8	R8	PB40B	4	PCLKC4_0/BDQ42	C
VCCIO	VCCIO	VCCIO4	4		
T5	T5	PB41A	4	BDQ42	T
T6	T6	PB41B	4	BDQ42	C
T8	T8	PB42A	4	BDQS42	T
GND	GND	GNDIO4	-		
R7	R7	PB43A	4	BDQ42	T
T9	T9	PB42B	4	BDQ42	C
T7	T7	PB43B	4	BDQ42	C
L8	L8	PB44A	4	BDQ42	T
VCCIO	VCCIO	VCCIO4	4		
P8	P8	PB45A	4	BDQ42	T
L9	L9	PB44B	4	BDQ42	C
N8	N8	PB45B	4	BDQ42	C
R9	R9	PB46A	4	BDQ42	T
GND	GND	GNDIO4	-		
R10	R10	PB46B	4	BDQ42	C
-	VCC	VCCIO	4		
-	GND	GNDIO4	4		
N9	N9	PB56A	4	BDQ60	T
T10	T10	PB57A	4	BDQ60	T
M9	M9	PB56B	4	BDQ60	C
R11	R11	PB57B	4	BDQ60	C
P10	P10	PB58A	4	BDQ60	T
N11	N11	PB59A	4	BDQ60	T
VCCIO	VCCIO	VCCIO4	4		
N10	N10	PB58B	4	BDQ60	C
P11	P11	PB59B	4	BDQ60	C
T11	T11	PB60A	4	BDQS60	T
GND	GND	GNDIO4	-		
M11	M11	PB61A	4	BDQ60	T
T12	T12	PB60B	4	BDQ60	C

LFE2-20E/SE Logic Signal Connections: 256 fpBGA (Cont.)

LFE2-20E/SE					
Ball Number	Ball Number	Ball/Pad Function	Bank	Dual Function	Differential
L11	L11	PB61B	4	BDQ60	C
T13	T13	PB62A	4	BDQ60	T
R13	R13	PB63A	4	BDQ60	T
VCCIO	VCCIO	VCCIO4	4		
T14	T14	PB62B	4	BDQ60	C
P13	P13	PB63B	4	BDQ60	C
GND	GND	GNDIO4	-		
N12	N12	PB64A	4	VREF2_4/BDQ60	T
M12	M12	PB64B	4	VREF1_4/BDQ60	C
R15	R15	CFG2	8		
N14	N14	CFG1	8		
N13	N13	PROGRAMN	8		
N15	N15	CFG0	8		
P15	P15	PR44B	8	WRITEN	C
L12	L12	INITN	8		
N16	N16	PR43B	8	CSN	C
GND	GND	GNDIO8	-		
R14	R14	CCLK	8		
P14	P14	PR44A	8	CS1N	T
M13	M13	DONE	8		
R16	R16	PR42B	8	D1	C
VCCIO	VCCIO	VCCIO8	8		
M16	M16	PR43A	8	D0/SPIFASTN	T
P16	P16	PR42A	8	D2	T
L15	L15	PR41B	8	D3	C
GND	GND	GNDIO8	-		
L14	L14	PR40A	8	D6	T
L16	L16	PR41A	8	D4	T
L10	L10	PR39B	8	D7	C
L13	L13	PR40B	8	D5	C
VCCIO	VCCIO	VCCIO8	8		
K11	K11	PR39A	8	DI/CSSPI0N	T
K14	K14	PR38B	8	DOU/CSON	C
K13	K13	PR38A	8	BUSY/SISPI	T
GND	GND	GNDIO8	-		
K15	K15	PR31B	3	RLM0_GPLL_C_FB_A/RDQ34	C
VCCIO	VCCIO	VCCIO3	3		
K16	K16	PR31A	3	RLM0_GPLLT_FB_A/RDQ34	T
GND	GND	GNDIO3	-		
J16	J16	PR30B	3	RLM0_GPLL_C_IN_A**/RDQ34	C (LVDS)*
J15	J15	PR30A	3	RLM0_GPLLT_IN_A**/RDQ34	T (LVDS)*
J14	J14	RLM0_PLLCAP	3		

LFE2-20E/SE Logic Signal Connections: 256 fpBGA (Cont.)

LFE2-20E/SE					
Ball Number	Ball Number	Ball/Pad Function	Bank	Dual Function	Differential
J13	J13	PR28B	3	RLM0_GDLLC_FB_A/RDQ25	C
J12	J12	PR28A	3	RLM0_GDLLT_FB_A/RDQ25	T
H12	H12	PR27B	3	RLM0_GDLLC_IN_A**/RDQ25	C (LVDS)*
GND	GND	GNDIO3	-		
H13	H13	PR27A	3	RLM0_GDLLT_IN_A**/RDQ25	T (LVDS)*
H15	H15	PR22B	3	VREF2_3/RDQ25	C
VCCIO	VCCIO	VCCIO3	3		
H16	H16	PR22A	3	VREF1_3/RDQ25	T
H11	H11	PR21B	3	PCLKC3_0/RDQ25	C (LVDS)*
J11	J11	PR21A	3	PCLKT3_0/RDQ25	T (LVDS)*
G16	G16	PR19B	2	PCLKC2_0/RDQ16	C
GND	GND	GNDIO2	-		
G15	G15	PR19A	2	PCLKT2_0/RDQ16	T
F15	F15	PR17B	2	RDQ16	C
G11	G11	PR18B	2	RDQ16	C (LVDS)*
F14	F14	PR17A	2	RDQ16	T
VCCIO	VCCIO	VCCIO2	2		
F12	F12	PR18A	2	RDQ16	T (LVDS)*
G14	G14	PR16B	2	RDQ16	C (LVDS)*
G13	G13	PR16A	2	RDQS16	T (LVDS)*
GND	GND	GNDIO2	-		
F16	F16	PR14B	2	RDQ16	C (LVDS)*
F9	F9	PR15B	2	RDQ16	C
E16	E16	PR14A	2	RDQ16	T (LVDS)*
F10	F10	PR15A	2	RDQ16	T
VCCIO	VCCIO	VCCIO2	2		
D16	D16	PR13B	2	RDQ16	C
D15	D15	PR13A	2	RDQ16	T
C15	C15	PR6B	2	RDQ8	C (LVDS)*
C16	C16	PR7B	2	RDQ8	C
GND	GND	GNDIO2	-		
D14	D14	PR6A	2	RDQ8	T (LVDS)*
B16	B16	PR7A	2	RDQ8	T
F13	F13	PR2B	2	VREF2_2	C (LVDS)*
VCCIO	VCCIO	VCCIO2	2		
E13	E13	PR2A	2	VREF1_2	T (LVDS)*
F11	F11	PT64B	1	VREF2_1	C
E11	E11	PT64A	1	VREF1_1	T
GND	GND	GNDIO1	-		
A15	A15	PT63B	1		C
E12	E12	PT62B	1		C
B15	B15	PT63A	1		T

LFE2-20E/SE Logic Signal Connections: 256 fpBGA (Cont.)

LFE2-20E/SE					
Ball Number	Ball Number	Ball/Pad Function	Bank	Dual Function	Differential
VCCIO	VCCIO	VCCIO1	1		
D12	D12	PT62A	1		T
B14	B14	PT61B	1		C
C14	C14	PT60B	1		C
A14	A14	PT61A	1		T
D13	D13	PT60A	1		T
C13	C13	PT59B	1		C
GND	GND	GNDIO1	-		
A13	A13	PT58B	1		C
B13	B13	PT59A	1		T
VCCIO	VCCIO	VCCIO1	1		
A12	A12	PT58A	1		T
B11	B11	PT57B	1		C
D11	D11	PT56B	1		C
A11	A11	PT57A	1		T
C11	C11	PT56A	1		T
-	GND	GNDIO1	1		
-	VCC	VCCIO	1		
D10	D10	PT46B	1		C
C10	C10	PT46A	1		T
GND	GND	GNDIO1	-		
B10	B10	PT45B	1		C
A9	A9	PT44B	1		C
A10	A10	PT45A	1		T
B9	B9	PT44A	1		T
VCCIO	VCCIO	VCCIO1	1		
A8	A8	PT43B	1		C
D9	D9	PT42B	1		C
B8	B8	PT43A	1		T
C9	C9	PT42A	1		T
GND	GND	GNDIO1	-		
B7	B7	PT41B	1		C
E9	E9	PT40B	1		C
A7	A7	PT41A	1		T
D8	D8	PT40A	1		T
VCCIO	VCCIO	VCCIO1	1		
A6	A6	PT39B	1	PCLKC1_0	C
B6	B6	PT39A	1	PCLKT1_0	T
E6	E6	XRES	1		
F8	F8	PT37B	0	PCLKC0_0	C
GND	GND	GNDIO0	-		
E8	E8	PT37A	0	PCLKT0_0	T

LFE2-20E/SE Logic Signal Connections: 256 fpBGA (Cont.)

LFE2-20E/SE					
Ball Number	Ball Number	Ball/Pad Function	Bank	Dual Function	Differential
A5	A5	PT36B	0		C
A3	A3	PT35B	0		C
A4	A4	PT36A	0		T
VCCIO	VCCIO	VCCIO0	0		
B3	B3	PT35A	0		T
A2	A2	PT34B	0		C
C7	C7	PT33B	0		C
B2	B2	PT34A	0		T
D7	D7	PT33A	0		T
D6	D6	PT32B	0		C
GND	GND	GNDIO0	-		
F7	F7	PT31B	0		C
C6	C6	PT32A	0		T
VCCIO	VCCIO	VCCIO0	0		
F6	F6	PT31A	0		T
C4	C4	PT30B	0		C
B4	B4	PT30A	0		T
-	GND	GNDIO0	0		
-	VCC	VCCIO	0		
D5	D5	PT2B	0	VREF2_0	C
E5	E5	PT2A	0	VREF1_0	T
G7	G7	VCC	-		
G9	G9	VCC	-		
H7	H7	VCC	-		
J10	J10	VCC	-		
K10	K10	VCC	-		
K8	K8	VCC	-		
G8	G8	VCCAUX	-		
H10	H10	VCCAUX	-		
J7	J7	VCCAUX	-		
K9	K9	VCCAUX	-		
C5	C5	VCCIO0	0		
E7	E7	VCCIO0	0		
C12	C12	VCCIO1	1		
E10	E10	VCCIO1	1		
E14	E14	VCCIO2	2		
G12	G12	VCCIO2	2		
K12	K12	VCCIO3	3		
M14	M14	VCCIO3	3		
M10	M10	VCCIO4	4		
P12	P12	VCCIO4	4		
M7	M7	VCCIO5	5		

LFE2-20E/SE Logic Signal Connections: 256 fpBGA (Cont.)

LFE2-20E/SE					
Ball Number	Ball Number	Ball/Pad Function	Bank	Dual Function	Differential
P5	P5	VCCIO5	5		
K5	K5	VCCIO6	6		
M3	M3	VCCIO6	6		
E3	E3	VCCIO7	7		
G5	G5	VCCIO7	7		
T15	T15	VCCIO8	8		
A1	A1	GND	-		
A16	A16	GND	-		
B12	B12	GND	-		
B5	B5	GND	-		
C8	C8	GND	-		
E15	E15	GND	-		
E2	E2	GND	-		
H14	H14	GND	-		
H8	H8	GND	-		
H9	H9	GND	-		
J3	J3	GND	-		
J8	J8	GND	-		
J9	J9	GND	-		
M15	M15	GND	-		
M2	M2	GND	-		
P9	P9	GND	-		
R12	R12	GND	-		
R5	R5	GND	-		
T1	T1	GND	-		
T16	T16	GND	-		

* Supports true LVDS. Other differential signals must be emulated with external resistors.

** These dedicated input pins can be used for GPLLs or GDLLs within the respective quadrant.

Note: VCCIO and GND pads are used to determine the average DC current drawn by I/Os between GND/VCCIO connections, or between the last GND/VCCIO in an I/O bank and the end of an I/O bank. The substrate pads listed in the Pin Table do not necessarily have a one to one connection with a package ball or pin.

LFE2-12E/SE and LFE2-20E/SE Logic Signal Connections: 484 fpBGA

LFE2-12E/12SE					LFE2-20E/20SE			
Ball Number	Ball/Pad Function	Bank	Dual Function	Differential	Ball/Pad Function	Bank	Dual Function	Differential
E4	PL2A	7	VREF2_7	T (LVDS)*	PL2A	7	VREF2_7	T (LVDS)*
E5	PL2B	7	VREF1_7	C (LVDS)*	PL2B	7	VREF1_7	C (LVDS)*
-	-	-			GNDIO7	-		
E3	NC	-			PL4A	7	LDQ8	T (LVDS)*
F4	PL3A	7		T	PL5A	7	LDQ8	T
F3	NC	-			PL4B	7	LDQ8	C (LVDS)*
F5	PL3B	7		C	PL5B	7	LDQ8	C
VCCIO	VCCIO7	7			VCCIO7	7		
E2	PL4A	7		T (LVDS)*	PL6A	7	LDQ8	T (LVDS)*
G6	PL5A	7		T	PL7A	7	LDQ8	T
E1	PL4B	7		C (LVDS)*	PL6B	7	LDQ8	C (LVDS)*
G7	PL5B	7		C	PL7B	7	LDQ8	C
GNDIO	GNDIO7	-			GNDIO7	-		
F1	NC	-			PL9A	7	LDQ8	T
H4	NC	-			PL8A	7	LDQS8	T (LVDS)*
F2	NC	-			PL9B	7	LDQ8	C
-	-	-			VCCIO7	7		
H5	NC	-			PL8B	7	LDQ8	C (LVDS)*
G1	NC	-			PL11A	7	LDQ8	T
G3	NC	-			PL10A	7	LDQ8	T (LVDS)*
G2	NC	-			PL11B	7	LDQ8	C
-	-	-			GNDIO	-		
G4	NC	-			PL10B	7	LDQ8	C (LVDS)*
J4	PL7A	7	LDQ10	T	PL13A	7	LDQ16	T
H1	PL6A	7	LDQ10		PL12A	7	LDQ16	T (LVDS)*
J5	PL7B	7	LDQ10	C	PL13B	7	LDQ16	C
L6	PL9A	7	LDQ10	T	PL15A	7	LDQ16	T
VCCIO	VCCIO7	7			VCCIO7	7		
J2	PL8A	7	LDQ10	T (LVDS)*	PL14A	7	LDQ16	T (LVDS)*
L5	PL9B	7	LDQ10	C	PL15B	7	LDQ16	C
J1	PL8B	7	LDQ10	C (LVDS)*	PL14B	7	LDQ16	C (LVDS)*
K3	PL10A	7	LDQS10	T (LVDS)*	PL16A	7	LDQS16	T (LVDS)*
GNDIO	GNDIO7	-			GNDIO	-		
K4	PL10B	7	LDQ10	C (LVDS)*	PL16B	7	LDQ16	C (LVDS)*
K2	PL11A	7	LDQ10	T	PL17A	7	LDQ16	T
VCCIO	VCCIO7	7			VCCIO7	7		
K1	PL11B	7	LDQ10	C	PL17B	7	LDQ16	C
L4	PL12A	7	LDQ10	T (LVDS)*	PL18A	7	LDQ16	T (LVDS)*
GNDIO	GNDIO7	-			GNDIO	-		
L3	PL12B	7	LDQ10	C (LVDS)*	PL18B	7	LDQ16	C (LVDS)*
L2	PL13A	7	PCLKT7_0/LDQ10	T	PL19A	7	PCLKT7_0/LDQ16	T
L1	PL13B	7	PCLKC7_0/LDQ10	C	PL19B	7	PCLKC7_0/LDQ16	C
M5	PL15A	6	PCLKT6_0	T (LVDS)*	PL21A	6	PCLKT6_0/LDQ25	T (LVDS)*
VCCIO	VCCIO6	6			-	-		
M6	PL15B	6	PCLKC6_0	C (LVDS)*	PL21B	6	PCLKC6_0/LDQ25	C (LVDS)*

LFE2-12E/SE and LFE2-20E/SE Logic Signal Connections: 484 fpBGA

LFE2-12E/12SE					LFE2-20E/20SE			
Ball Number	Ball/Pad Function	Bank	Dual Function	Differential	Ball/Pad Function	Bank	Dual Function	Differential
M3	PL16A	6	VREF2_6	T	PL22A	6	VREF2_6/LDQ25	T
GNDIO	GNDIO6	-			-	-		
M4	PL16B	6	VREF1_6	C	PL22B	6	VREF1_6/LDQ25	C
-	-	-			VCCIO6	6		
N1	NC	-			PL24A	6	LDQ25	T
M2	NC	-			PL23A	6	LDQ25	T (LVDS)*
N2	NC	-			PL24B	6	LDQ25	C
M1	NC	-			PL23B	6	LDQ25	C (LVDS)*
-	-	-			GNDIO	-		
N3	NC	-			PL25A	6	LDQS25	T (LVDS)*
N5	NC	-			PL26A	6	LDQ25	T
N4	NC	-			PL25B	6	LDQ25	C (LVDS)*
-	-	-			VCCIO6	6		
P5	NC	-			PL26B	6	LDQ25	C
P1	PL17A	6	LLM0_GDLLT_IN_A**	T (LVDS)*	PL27A	6	LLM0_GDLLT_IN_A**/LDQ25	T (LVDS)*
P2	PL17B	6	LLM0_GDLLC_IN_A**	C (LVDS)*	PL27B	6	LLM0_GDLLC_IN_A**/LDQ25	C (LVDS)*
P4	PL18A	6	LLM0_GDLLT_FB_A	T	PL28A	6	LLM0_GDLLT_FB_A/LDQ25	T
-	-	-			GNDIO	-		
R4	PL18B	6	LLM0_GDLLC_FB_A	C	PL28B	6	LLM0_GDLLC_FB_A/LDQ25	C
P6	LLM0_PLCCAP	6			LLM0_PLCCAP	6		
R1	PL20A	6	LLM0_GPLLT_IN_A**	T (LVDS)*	PL30A	6	LLM0_GPLLT_IN_A**/LDQ34	T (LVDS)*
GNDIO	GNDIO6	-			-	-		
R3	PL21A	6	LLM0_GPLLT_FB_A	T	PL31A	6	LLM0_GPLLT_FB_A/LDQ34	T
R2	PL20B	6	LLM0_GPLLC_IN_A**	C (LVDS)*	PL30B	6	LLM0_GPLLC_IN_A**/LDQ34	C (LVDS)*
T4	PL21B	6	LLM0_GPLLC_FB_A	C	PL31B	6	LLM0_GPLLC_FB_A/LDQ34	C
T5	PL23A	6		T	PL33A	6	LDQ34	T
VCCIO	VCCIO6	6			VCCIO6	6		
T1	PL22A	6		T (LVDS)*	PL32A	6	LDQ34	T (LVDS)*
T3	PL23B	6		C	PL33B	6	LDQ34	C
T2	PL22B	6		C (LVDS)*	PL32B	6	LDQ34	C (LVDS)*
GNDIO	GNDIO6	-			GNDIO6	-		
-	-	-			VCCIO6	6		
V1	PL25A	6	LDQ28	T	PL39A	6	LDQ42	T
-	-	-			GNDIO	-		
V2	PL25B	6	LDQ28	C	PL39B	6	LDQ42	C
U1	PL24A	6	LDQ28	T (LVDS)*	PL38A	6	LDQ42	T (LVDS)*
U3	PL27A	6	LDQ28	T	PL41A	6	LDQ42	T
VCCIO	VCCIO6	6			VCCIO6	6		
U2	PL24B	6	LDQ28	C (LVDS)*	PL38B	6	LDQ42	C (LVDS)*
U4	PL27B	6	LDQ28	C	PL41B	6	LDQ42	C
R6	PL26A	6	LDQ28	T (LVDS)*	PL40A	6	LDQ42	T (LVDS)*
R7	PL29A	6	LDQ28	T	PL43A	6	LDQ42	T
GNDIO	GNDIO6	-			GNDIO	-		
T7	PL29B	6	LDQ28	C	PL43B	6	LDQ42	C
T6	PL26B	6	LDQ28	C (LVDS)*	PL40B	6	LDQ42	C (LVDS)*

LFE2-12E/SE and LFE2-20E/SE Logic Signal Connections: 484 fpBGA

LFE2-12E/12SE					LFE2-20E/20SE			
Ball Number	Ball/Pad Function	Bank	Dual Function	Differential	Ball/Pad Function	Bank	Dual Function	Differential
AA2	PL31A	6	LDQ28	T	PL45A	6	LDQ42	T
VCCIO	VCCIO6	6			VCCIO6	6		
Y1	PL28A	6	LDQS28	T (LVDS)*	PL42A	6	LDQS42	T (LVDS)*
AA1	PL31B	6	LDQ28	C	PL45B	6	LDQ42	C
W1	PL28B	6	LDQ28	C (LVDS)*	PL42B	6	LDQ42	C (LVDS)*
V3	PL30B	6	LDQ28	C (LVDS)*	PL44B	6	LDQ42	C (LVDS)*
GNDIO	GNDIO6	-			GNDIO	-		
V4	PL30A	6	LDQ28	T (LVDS)*	PL44A	6	LDQ42	T (LVDS)*
U5	TDI	-			TDI	-		
U7	TCK	-			TCK	-		
V6	TDO	-			TDO	-		
V5	TMS	-			TMS	-		
T8	VCCJ	-			VCCJ	-		
W4	PB3A	5	BDQ6	T	PB3A	5	BDQ6	T
Y3	PB2A	5	VREF2_5/BDQ6	T	PB2A	5	VREF2_5/BDQ6	T
W3	PB3B	5	BDQ6	C	PB3B	5	BDQ6	C
Y2	PB2B	5	VREF1_5/BDQ6	C	PB2B	5	VREF1_5/BDQ6	C
AB3	PB5A	5	BDQ6	T	PB5A	5	BDQ6	T
VCCIO	VCCIO5	5			VCCIO5	5		
W5	PB4A	5	BDQ6	T	PB4A	5	BDQ6	T
AB2	PB5B	5	BDQ6	C	PB5B	5	BDQ6	C
W6	PB4B	5	BDQ6	C	PB4B	5	BDQ6	C
AB5	PB7A	5	BDQ6	T	PB7A	5	BDQ6	T
GNDIO	GNDIO5	-			GNDIO	-		
Y4	PB6A	5	BDQS6	T	PB6A	5	BDQS6	T
AB4	PB7B	5	BDQ6	C	PB7B	5	BDQ6	C
AA3	PB6B	5	BDQ6	C	PB6B	5	BDQ6	C
AB6	PB9A	5	BDQ6	T	PB9A	5	BDQ6	T
VCCIO	VCCIO5	5			VCCIO5	5		
AA5	PB8A	5	BDQ6	T	PB8A	5	BDQ6	T
AA6	PB9B	5	BDQ6	C	PB9B	5	BDQ6	C
Y5	PB8B	5	BDQ6	C	PB8B	5	BDQ6	C
GNDIO	GNDIO5	-			GNDIO	-		
-	-	-			VCCIO5	5		
Y6	PB12A	5	BDQ15	T	PB21A	5	BDQ24	T
W7	PB11A	5	BDQ15	T	PB20A	5	BDQ24	T
Y7	PB12B	5	BDQ15	C	PB21B	5	BDQ24	C
W8	PB11B	5	BDQ15	C	PB20B	5	BDQ24	C
U8	PB14A	5	BDQ15	T	PB23A	5	BDQ24	T
VCCIO	VCCIO5	5			VCCIO5	5		
AA7	PB13A	5	BDQ15	T	PB22A	5	BDQ24	T
U9	PB14B	5	BDQ15	C	PB23B	5	BDQ24	C
AB7	PB13B	5	BDQ15	C	PB22B	5	BDQ24	C
Y8	PB16A	5	BDQ15	T	PB25A	5	BDQ24	T
GNDIO	GNDIO5	-			GNDIO	-		

LFE2-12E/SE and LFE2-20E/SE Logic Signal Connections: 484 fpBGA

LFE2-12E/12SE					LFE2-20E/20SE			
Ball Number	Ball/Pad Function	Bank	Dual Function	Differential	Ball/Pad Function	Bank	Dual Function	Differential
W9	PB15A	5	BDQS15	T	PB24A	5	BDQS24	T
AA8	PB16B	5	BDQ15	C	PB25B	5	BDQ24	C
V9	PB15B	5	BDQ15	C	PB24B	5	BDQ24	C
AB8	PB18A	5	BDQ15	T	PB27A	5	BDQ24	T
VCCIO	VCCIO5	5			VCCIO5	5		
W10	PB17A	5	BDQ15	T	PB26A	5	BDQ24	T
AA9	PB18B	5	BDQ15	C	PB27B	5	BDQ24	C
V10	PB17B	5	BDQ15	C	PB26B	5	BDQ24	C
GNDIO	GNDIO5	-			GNDIO	-		
Y10	PB21A	5	BDQ24	T	PB30A	5	BDQ33	T
AB9	PB20A	5	BDQ24	T	PB29A	5	BDQ33	T
AA10	PB21B	5	BDQ24	C	PB30B	5	BDQ33	C
AB10	PB20B	5	BDQ24	C	PB29B	5	BDQ33	C
AB11	PB23A	5	BDQ24	T	PB32A	5	BDQ33	T
U10	PB22A	5	BDQ24	T	PB31A	5	BDQ33	T
VCCIO	VCCIO5	5			VCCIO5	5		
AA11	PB23B	5	BDQ24	C	PB32B	5	BDQ33	C
U11	PB22B	5	BDQ24	C	PB31B	5	BDQ33	C
GNDIO	GNDIO5	-			GNDIO5	-		
AB12	PB25A	5	BDQ24	T	PB34A	5	BDQ33	T
Y11	PB24A	5	BDQS24	T	PB33A	5	BDQS33	T
AA12	PB25B	5	BDQ24	C	PB34B	5	BDQ33	C
W11	PB24B	5	BDQ24	C	PB33B	5	BDQ33	C
AB13	PB26A	5	PCLKT5_0/BDQ24	T	PB35A	5	PCLKT5_0/BDQ33	T
VCCIO	VCCIO5	5			VCCIO5	5		
AB14	PB26B	5	PCLKC5_0/BDQ24	C	PB35B	5	PCLKC5_0/BDQ33	C
GNDIO	GNDIO5	-			GNDIO5	-		
Y12	PB32A	4	BDQ33	T	PB41A	4	BDQ42	T
W12	PB32B	4	BDQ33	C	PB41B	4	BDQ42	C
VCCIO	VCCIO4	4			VCCIO4	4		
U12	PB31A	4	PCLKT4_0/BDQ33	T	PB40A	4	PCLKT4_0/BDQ42	T
V12	PB31B	4	PCLKC4_0/BDQ33	C	PB40B	4	PCLKC4_0/BDQ42	C
U13	PB34A	4	BDQ33	T	PB43A	4	BDQ42	T
GNDIO	GNDIO4	-			GNDIO4	-		
AA13	PB33A	4	BDQS33	T	PB42A	4	BDQS42	T
U14	PB34B	4	BDQ33	C	PB43B	4	BDQ42	C
Y13	PB33B	4	BDQ33	C	PB42B	4	BDQ42	C
AB16	PB36A	4	BDQ33	T	PB45A	4	BDQ42	T
VCCIO	VCCIO4	4			VCCIO4	4		
AB15	PB35A	4	BDQ33	T	PB44A	4	BDQ42	T
AB17	PB36B	4	BDQ33	C	PB45B	4	BDQ42	C
AA14	PB35B	4	BDQ33	C	PB44B	4	BDQ42	C
W13	PB37A	4	BDQ33	T	PB46A	4	BDQ42	T
GNDIO	GNDIO4	-			GNDIO4	-		
W14	PB37B	4	BDQ33	C	PB46B	4	BDQ42	C

LFE2-12E/SE and LFE2-20E/SE Logic Signal Connections: 484 fpBGA

LFE2-12E/12SE					LFE2-20E/20SE			
Ball Number	Ball/Pad Function	Bank	Dual Function	Differential	Ball/Pad Function	Bank	Dual Function	Differential
AB18	PB39A	4	BDQ42	T	PB48A	4	BDQ51	T
AB19	PB39B	4	BDQ42	C	PB48B	4	BDQ51	C
Y15	PB41A	4	BDQ42	T	PB50A	4	BDQ51	T
V14	PB40A	4	BDQ42	T	PB49A	4	BDQ51	T
VCCIO	VCCIO4	4			VCCIO4	4		
AA15	PB41B	4	BDQ42	C	PB50B	4	BDQ51	C
W15	PB40B	4	BDQ42	C	PB49B	4	BDQ51	C
GNDIO	GNDIO4	-			GNDIO	-		
AB20	PB43A	4	BDQ42	T	PB52A	4	BDQ51	T
AA16	PB42A	4	BDQS42	T	PB51A	4	BDQS51	T
AB21	PB43B	4	BDQ42	C	PB52B	4	BDQ51	C
AA17	PB42B	4	BDQ42	C	PB51B	4	BDQ51	C
Y16	PB45A	4	BDQ42	T	PB54A	4	BDQ51	T
U15	PB44A	4	BDQ42	T	PB53A	4	BDQ51	T
VCCIO	VCCIO4	4			VCCIO4	4		
W16	PB45B	4	BDQ42	C	PB54B	4	BDQ51	C
U16	PB44B	4	BDQ42	C	PB53B	4	BDQ51	C
AA18	PB46A	4	BDQ42	T	PB55A	4	BDQ51	T
AA20	PB46B	4	BDQ42	C	PB55B	4	BDQ51	C
GNDIO	GNDIO4	-			GNDIO	-		
V16	PB49A	4	BDQ51	T	PB58A	4	BDQ60	T
V17	PB49B	4	BDQ51	C	PB58B	4	BDQ60	C
AA21	PB48A	4	BDQ51	T	PB57A	4	BDQ60	T
VCCIO	VCCIO4	4			VCCIO4	4		
Y19	PB51A	4	BDQS51	T	PB60A	4	BDQS60	T
AA22	PB48B	4	BDQ51	C	PB57B	4	BDQ60	C
Y20	PB51B	4	BDQ51	C	PB60B	4	BDQ60	C
Y18	PB50A	4	BDQ51	T	PB59A	4	BDQ60	T
GNDIO	GNDIO4	-			GNDIO4	-		
Y21	PB53A	4	BDQ51	T	PB62A	4	BDQ60	T
Y17	PB50B	4	BDQ51	C	PB59B	4	BDQ60	C
Y22	PB53B	4	BDQ51	C	PB62B	4	BDQ60	C
W17	PB52A	4	BDQ51	T	PB61A	4	BDQ60	T
VCCIO	VCCIO4	4			VCCIO4	4		
U18	PB54A	4	BDQ51	T	PB63A	4	BDQ60	T
W18	PB52B	4	BDQ51	C	PB61B	4	BDQ60	C
V18	PB54B	4	BDQ51	C	PB63B	4	BDQ60	C
GNDIO	GNDIO4	-			GNDIO4	-		
T15	PB55A	4	VREF2_4/BDQ51	T	PB64A	4	VREF2_4/BDQ60	T
T16	PB55B	4	VREF1_4/BDQ51	C	PB64B	4	VREF1_4/BDQ60	C
W19	CFG2	8			CFG2	8		
V19	CFG1	8			CFG1	8		
V20	PROGRAMN	8			PROGRAMN	8		
W20	CFG0	8			CFG0	8		
U22	PR28B	8	D1/SPID6	C	PR42B	8	D1/SPID6	C

LFE2-12E/SE and LFE2-20E/SE Logic Signal Connections: 484 fpBGA

LFE2-12E/12SE					LFE2-20E/20SE			
Ball Number	Ball/Pad Function	Bank	Dual Function	Differential	Ball/Pad Function	Bank	Dual Function	Differential
V22	INITN	8			INITN	8		
R16	PR30B	8	WRITEN	C	PR44B	8	WRITEN	C
GNDIO	GNDIO8	-			GNDIO8	-		
W22	CCLK	8			CCLK	8		
R17	PR30A	8	CS1N	T	PR44A	8	CS1N	T
V21	DONE	8			DONE	8		
VCCIO	VCCIO8	8			VCCIO8	8		
U19	PR29B	8	CSN	C	PR43B	8	CSN	C
T17	PR26B	8	D5	C	PR40B	8	D5	C
U20	PR29A	8	D0/SPIFASTN	T	PR43A	8	D0/SPIFASTN	T
U21	PR28A	8	D2	T	PR42A	8	D2	T
GNDIO	GNDIO8	-			GNDIO8	-		
T18	PR26A	8	D6	T	PR40A	8	D6	T
T20	PR27B	8	D3	C	PR41B	8	D3	C
T21	PR25B	8	D7	C	PR39B	8	D7	C
T19	PR27A	8	D4	T	PR41A	8	D4	T
VCCIO	VCCIO8	8			VCCIO8	8		
T22	PR25A	8	DI/CSSPI0N	T	PR39A	8	DI/CSSPI0N	T
R18	PR24B	8	DOUT/CSON	C	PR38B	8	DOUT/CSON	C
R19	PR24A	8	BUSY/SISPI	T	PR38A	8	BUSY/SISPI	T
-	-	-			VCCIO3	3		
GNDIO	GNDIO3	-			GNDIO3	-		
P18	PR22B	3		C (LVDS)*	PR32B	3	RDQ34	C (LVDS)*
R22	PR23B	3		C	PR33B	3	RDQ34	C
P19	PR22A	3		T (LVDS)*	PR32A	3	RDQ34	T (LVDS)*
R21	PR23A	3		T	PR33A	3	RDQ34	T
VCCIO	VCCIO3	3			VCCIO3	3		
R20	PR21B	3	RLM0_GPLL_C_FB_A	C	PR31B	3	RLM0_GPLL_C_FB_A/RDQ34	C
P22	PR21A	3	RLM0_GPLLT_FB_A	T	PR31A	3	RLM0_GPLLT_FB_A/RDQ34	T
P21	PR20B	3	RLM0_GPLL_C_IN_A**	C (LVDS)*	PR30B	3	RLM0_GPLL_C_IN_A**/RDQ34	C (LVDS)*
N21	PR20A	3	RLM0_GPLLT_IN_A**	T (LVDS)*	PR30A	3	RLM0_GPLLT_IN_A**/RDQ34	T (LVDS)*
N17	RLM0_PLLCAP	3			RLM0_PLLCAP	3		
N22	PR18B	3	RLM0_GDLL_C_FB_A	C	PR28B	3	RLM0_GDLL_C_FB_A/RDQ25	C
M22	PR17B	3	RLM0_GDLL_C_IN_A**	C (LVDS)*	PR27B	3	RLM0_GDLL_C_IN_A**/RDQ25	C (LVDS)*
GNDIO	GNDIO3	-			GNDIO3	-		
N20	PR18A	3	RLM0_GDLLT_FB_A	T	PR28A	3	RLM0_GDLLT_FB_A/RDQ25	T
M21	PR17A	3	RLM0_GDLLT_IN_A**	T (LVDS)*	PR27A	3	RLM0_GDLLT_IN_A**/RDQ25	T (LVDS)*
N19	NC	-			PR26B	3	RDQ25	C
-	-	-			VCCIO3	3		
M19	NC	-			PR26A	3	RDQ25	T
J22	NC	-			PR23B	3	RDQ25	C (LVDS)*
-	-	-			GNDIO	-		
L22	NC	-			PR24B	3	RDQ25	C
H22	NC	-			PR23A	3	RDQ25	T (LVDS)*
K22	NC	-			PR24A	3	RDQ25	T

LFE2-12E/SE and LFE2-20E/SE Logic Signal Connections: 484 fpBGA

LFE2-12E/12SE					LFE2-20E/20SE			
Ball Number	Ball/Pad Function	Bank	Dual Function	Differential	Ball/Pad Function	Bank	Dual Function	Differential
M20	PR16B	3	VREF2_3	C	PR22B	3	VREF2_3/RDQ25	C
VCCIO	VCCIO3	3			VCCIO3	3		
L21	PR16A	3	VREF1_3	T	PR22A	3	VREF1_3/RDQ25	T
K21	PR15B	3	PCLKC3_0	C (LVDS)*	PR21B	3	PCLKC3_0/RDQ25	C (LVDS)*
J21	PR15A	3	PCLKT3_0	T (LVDS)*	PR21A	3	PCLKT3_0/RDQ25	T (LVDS)*
M18	PR13B	2	PCLKC2_0/RDQ10	C	PR19B	2	PCLKC2_0/RDQ16	C
GNDIO	GNDIO2	-			GNDIO2	-		
L17	PR13A	2	PCLKT2_0/RDQ10	T	PR19A	2	PCLKT2_0/RDQ16	T
L19	PR12B	2	RDQ10	C (LVDS)*	PR18B	2	RDQ16	C (LVDS)*
K18	PR10B	2	RDQ10	C (LVDS)*	PR16B	2	RDQ16	C (LVDS)*
L20	PR12A	2	RDQ10	T (LVDS)*	PR18A	2	RDQ16	T (LVDS)*
VCCIO	VCCIO2	2			VCCIO2	2		
K19	PR10A	2	RDQS10	T (LVDS)*	PR16A	2	RDQS16	T (LVDS)*
L18	PR11B	2	RDQ10	C	PR17B	2	RDQ16	C
K17	PR11A	2	RDQ10	T	PR17A	2	RDQ16	T
GNDIO	GNDIO2	-			GNDIO2	-		
J17	PR8B	2	RDQ10	C (LVDS)*	PR14B	2	RDQ16	C (LVDS)*
G22	PR9B	2	RDQ10	C	PR15B	2	RDQ16	C
J18	PR8A	2	RDQ10	T (LVDS)*	PR14A	2	RDQ16	T (LVDS)*
F22	PR9A	2	RDQ10	T	PR15A	2	RDQ16	T
VCCIO	VCCIO2	2			VCCIO2	2		
H21	PR6B	2	RDQ10	C (LVDS)*	PR12B	2	RDQ16	C (LVDS)*
K20	PR7B	2	RDQ10	C	PR13B	2	RDQ16	C
G21	PR6A	2	RDQ10	T (LVDS)*	PR12A	2	RDQ16	T (LVDS)*
J19	PR7A	2	RDQ10	T	PR13A	2	RDQ16	T
D22	NC	-			PR10B	2	RDQ8	C (LVDS)*
F21	NC	-			PR11B	2	RDQ8	C
-	-	-			GNDIO	-		
E21	NC	-			PR10A	2	RDQ8	T (LVDS)*
E22	NC	-			PR11A	2	RDQ8	T
H19	NC	-			PR8B	2	RDQ8	C (LVDS)*
G20	NC	-			PR9B	2	RDQ8	C
-	-	-			VCCIO2	2		
G19	NC	-			PR8A	2	RDQS8	T (LVDS)*
F20	NC	-			PR9A	2	RDQ8	T
G17	PR5B	2		C	PR7B	2	RDQ8	C
GNDIO	GNDIO2	-			GNDIO2	-		
E20	PR4B	2		C (LVDS)*	PR6B	2	RDQ8	C (LVDS)*
F19	PR5A	2		T	PR7A	2	RDQ8	T
D20	PR4A	2		T (LVDS)*	PR6A	2	RDQ8	T (LVDS)*
F18	PR3B	2		C	PR5B	2	RDQ8	C
VCCIO	VCCIO2	2			VCCIO2	2		
C21	NC	-			PR4B	2	RDQ8	C (LVDS)*
F16	PR3A	2		T	PR5A	2	RDQ8	T
C22	NC	-			PR4A	2	RDQ8	T (LVDS)*

LFE2-12E/SE and LFE2-20E/SE Logic Signal Connections: 484 fpBGA

LFE2-12E/12SE					LFE2-20E/20SE			
Ball Number	Ball/Pad Function	Bank	Dual Function	Differential	Ball/Pad Function	Bank	Dual Function	Differential
-	-	-			GNDIO	-		
D19	PR2B	2	VREF2_2	C (LVDS)*	PR2B	2	VREF2_2	C (LVDS)*
E19	PR2A	2	VREF1_2	T (LVDS)*	PR2A	2	VREF1_2	T (LVDS)*
B21	PT55B	1	VREF2_1	C	PT64B	1	VREF2_1	C
B22	PT55A	1	VREF1_1	T	PT64A	1	VREF1_1	T
GNDIO	GNDIO1	-			GNDIO1	-		
D18	PT53B	1		C	PT62B	1		C
C20	PT54B	1		C	PT63B	1		C
E18	PT53A	1		T	PT62A	1		T
C19	PT54A	1		T	PT63A	1		T
VCCIO	VCCIO1	1			VCCIO1	1		
D17	PT51B	1		C	PT60B	1		C
B20	PT52B	1		C	PT61B	1		C
C18	PT51A	1		T	PT60A	1		T
A19	PT52A	1		T	PT61A	1		T
GNDIO	GNDIO1	-			GNDIO1	-		
A18	PT49B	1		C	PT58B	1		C
A21	PT50B	1		C	PT59B	1		C
B18	PT49A	1		T	PT58A	1		T
A20	PT50A	1		T	PT59A	1		T
VCCIO	VCCIO1	1			VCCIO1	1		
D16	PT47B	1		C	PT56B	1		C
G16	PT48B	1		C	PT57B	1		C
E16	PT47A	1		T	PT56A	1		T
G15	PT48A	1		T	PT57A	1		T
C17	PT46B	1		C	PT55B	1		C
GNDIO	GNDIO1	-			GNDIO1	-		
C16	PT46A	1		T	PT55A	1		T
A17	PT44B	1		C	PT53B	1		C
B17	PT45B	1		C	PT54B	1		C
A16	PT44A	1		T	PT53A	1		T
VCCIO	VCCIO1	1			VCCIO1	1		
B16	PT45A	1		T	PT54A	1		T
E15	PT42B	1		C	PT51B	1		C
C15	PT43B	1		C	PT52B	1		C
F15	PT42A	1		T	PT51A	1		T
D15	PT43A	1		T	PT52A	1		T
B15	PT40B	1		C	PT49B	1		C
GNDIO	GNDIO1	-			GNDIO1	-		
A15	PT40A	1		T	PT49A	1		T
VCCIO	VCCIO1	1			VCCIO1	1		
A14	PT39A	1		T	PT48A	1		T
B14	PT39B	1		C	PT48B	1		C
D14	PT37B	1		C	PT46B	1		C
E14	PT36B	1		C	PT45B	1		C

LFE2-12E/SE and LFE2-20E/SE Logic Signal Connections: 484 fpBGA

LFE2-12E/12SE					LFE2-20E/20SE			
Ball Number	Ball/Pad Function	Bank	Dual Function	Differential	Ball/Pad Function	Bank	Dual Function	Differential
GNDIO	GNDIO1	-			GNDIO1	-		
C13	PT37A	1		T	PT46A	1		T
F14	PT36A	1		T	PT45A	1		T
A13	PT35B	1		C	PT44B	1		C
E13	PT34B	1		C	PT43B	1		C
VCCIO	VCCIO1	1			VCCIO1	1		
B13	PT35A	1		T	PT44A	1		T
D13	PT34A	1		T	PT43A	1		T
E12	PT33B	1		C	PT42B	1		C
GNDIO	GNDIO1	-			GNDIO1	-		
D12	PT33A	1		T	PT42A	1		T
A12	PT31B	1		C	PT40B	1		C
B12	PT30B	1	PCLKC1_0	C	PT39B	1	PCLKC1_0	C
VCCIO	VCCIO1	1			VCCIO1	1		
A11	PT31A	1		T	PT40A	1		T
C12	PT30A	1	PCLKT1_0	T	PT39A	1	PCLKT1_0	T
F12	XRES	1			XRES	1		
B10	PT28B	0	PCLKC0_0	C	PT37B	0	PCLKC0_0	C
GNDIO	GNDIO0	-			GNDIO0	-		
B11	PT28A	0	PCLKT0_0	T	PT37A	0	PCLKT0_0	T
C11	PT26B	0		C	PT35B	0		C
A10	PT27B	0		C	PT36B	0		C
C10	PT26A	0		T	PT35A	0		T
VCCIO	VCCIO0	0			VCCIO0	0		
A9	PT27A	0		T	PT36A	0		T
A8	PT24B	0		C	PT33B	0		C
E11	PT25B	0		C	PT34B	0		C
A7	PT24A	0		T	PT33A	0		T
F11	PT25A	0		T	PT34A	0		T
GNDIO	GNDIO0	-			GNDIO0	-		
B8	PT23B	0		C	PT32B	0		C
VCCIO	VCCIO0	0			VCCIO0	0		
B9	PT23A	0		T	PT32A	0		T
C8	PT20B	0		C	PT29B	0		C
B7	PT21B	0		C	PT30B	0		C
D8	PT20A	0		T	PT29A	0		T
A6	PT21A	0		T	PT30A	0		T
GNDIO	GNDIO0	-			GNDIO0	-		
C7	PT17B	0		C	PT26B	0		C
D10	PT18B	0		C	PT27B	0		C
C6	PT17A	0		T	PT26A	0		T
E10	PT18A	0		T	PT27A	0		T
VCCIO	VCCIO0	0			VCCIO0	0		
F10	PT15B	0		C	PT24B	0		C
B6	PT16B	0		C	PT25B	0		C

LFE2-12E/SE and LFE2-20E/SE Logic Signal Connections: 484 fpBGA

LFE2-12E/12SE					LFE2-20E/20SE			
Ball Number	Ball/Pad Function	Bank	Dual Function	Differential	Ball/Pad Function	Bank	Dual Function	Differential
D9	PT15A	0		T	PT24A	0		T
B5	PT16A	0		T	PT25A	0		T
GNDIO	GNDIO0	-			GNDIO0	-		
A5	PT13B	0		C	PT22B	0		C
F9	PT14B	0		C	PT23B	0		C
A4	PT13A	0		T	PT22A	0		T
E9	PT14A	0		T	PT23A	0		T
VCCIO	VCCIO0	0			VCCIO0	0		
G8	PT11B	0		C	PT20B	0		C
A3	PT12B	0		C	PT21B	0		C
E8	PT11A	0		T	PT20A	0		T
A2	PT12A	0		T	PT21A	0		T
GNDIO	GNDIO0	-			GNDIO0	-		
-	-	-			VCCIO0	0		
C3	PT10B	0		C	PT10B	0		C
B3	PT10A	0		T	PT10A	0		T
-	-	-			GNDIO0	-		
E7	PT8B	0		C	PT8B	0		C
F8	PT9B	0		C	PT9B	0		C
F7	PT8A	0		T	PT8A	0		T
D7	PT9A	0		T	PT9A	0		T
VCCIO	VCCIO0	0			VCCIO0	0		
D4	PT6B	0		C	PT6B	0		C
D5	PT7B	0		C	PT7B	0		C
C4	PT6A	0		T	PT6A	0		T
D6	PT7A	0		T	PT7A	0		T
GNDIO	GNDIO0	-			GNDIO	-		
J7	PT4B	0		C	PT4B	0		C
B2	PT5B	0		C	PT5B	0		C
H7	PT4A	0		T	PT4A	0		T
B1	PT5A	0		T	PT5A	0		T
VCCIO	VCCIO0	0			VCCIO0	0		
D1	PT2B	0	VREF2_0	C	PT2B	0	VREF2_0	C
D3	PT3B	0		C	PT3B	0		C
C1	PT2A	0	VREF1_0	T	PT2A	0	VREF1_0	T
C2	PT3A	0		T	PT3A	0		T
J10	VCC	-			VCC	-		
J11	VCC	-			VCC	-		
J12	VCC	-			VCC	-		
J13	VCC	-			VCC	-		
K14	VCC	-			VCC	-		
K9	VCC	-			VCC	-		
L14	VCC	-			VCC	-		
L9	VCC	-			VCC	-		
M14	VCC	-			VCC	-		

LFE2-12E/SE and LFE2-20E/SE Logic Signal Connections: 484 fpBGA

LFE2-12E/12SE					LFE2-20E/20SE			
Ball Number	Ball/Pad Function	Bank	Dual Function	Differential	Ball/Pad Function	Bank	Dual Function	Differential
M9	VCC	-			VCC	-		
N14	VCC	-			VCC	-		
N9	VCC	-			VCC	-		
P10	VCC	-			VCC	-		
P11	VCC	-			VCC	-		
P12	VCC	-			VCC	-		
P13	VCC	-			VCC	-		
G10	VCCIO0	0			VCCIO0	0		
G9	VCCIO0	0			VCCIO0	0		
H9	VCCIO0	0			VCCIO0	0		
H8	VCCIO0	0			VCCIO0	0		
G11	VCCIO1	1			VCCIO1	1		
G12	VCCIO1	1			VCCIO1	1		
G13	VCCIO1	1			VCCIO1	1		
G14	VCCIO1	1			VCCIO1	1		
H14	VCCIO2	2			VCCIO2	2		
H15	VCCIO2	2			VCCIO2	2		
J15	VCCIO2	2			VCCIO2	2		
K16	VCCIO2	2			VCCIO2	2		
L16	VCCIO3	3			VCCIO3	3		
M16	VCCIO3	3			VCCIO3	3		
N16	VCCIO3	3			VCCIO3	3		
P16	VCCIO3	3			VCCIO3	3		
R14	VCCIO4	4			VCCIO4	4		
T12	VCCIO4	4			VCCIO4	4		
T13	VCCIO4	4			VCCIO4	4		
T14	VCCIO4	4			VCCIO4	4		
R9	VCCIO5	5			VCCIO5	5		
T10	VCCIO5	5			VCCIO5	5		
T11	VCCIO5	5			VCCIO5	5		
T9	VCCIO5	5			VCCIO5	5		
N7	VCCIO6	6			VCCIO6	6		
P7	VCCIO6	6			VCCIO6	6		
P8	VCCIO6	6			VCCIO6	6		
R8	VCCIO6	6			VCCIO6	6		
J8	VCCIO7	7			VCCIO7	7		
K7	VCCIO7	7			VCCIO7	7		
L7	VCCIO7	7			VCCIO7	7		
M7	VCCIO7	7			VCCIO7	7		
P15	VCCIO8	8			VCCIO8	8		
R15	VCCIO8	8			VCCIO8	8		
C5	VCCAUX	-			VCCAUX	-		
D11	VCCAUX	-			VCCAUX	-		
E17	VCCAUX	-			VCCAUX	-		
E6	VCCAUX	-			VCCAUX	-		

LFE2-12E/SE and LFE2-20E/SE Logic Signal Connections: 484 fpBGA

LFE2-12E/12SE					LFE2-20E/20SE			
Ball Number	Ball/Pad Function	Bank	Dual Function	Differential	Ball/Pad Function	Bank	Dual Function	Differential
F13	VCCAUX	-			VCCAUX	-		
G18	VCCAUX	-			VCCAUX	-		
G5	VCCAUX	-			VCCAUX	-		
K5	VCCAUX	-			VCCAUX	-		
M17	VCCAUX	-			VCCAUX	-		
P17	VCCAUX	-			VCCAUX	-		
R5	VCCAUX	-			VCCAUX	-		
V11	VCCAUX	-			VCCAUX	-		
V13	VCCAUX	-			VCCAUX	-		
V15	VCCAUX	-			VCCAUX	-		
V7	VCCAUX	-			VCCAUX	-		
V8	VCCAUX	-			VCCAUX	-		
A1	GND	-			GND	-		
A22	GND	-			GND	-		
AA19	GND	-			GND	-		
AA4	GND	-			GND	-		
AB1	GND	-			GND	-		
AB22	GND	-			GND	-		
B19	GND	-			GND	-		
B4	GND	-			GND	-		
C14	GND	-			GND	-		
C9	GND	-			GND	-		
D2	GND	-			GND	-		
D21	GND	-			GND	-		
F17	GND	-			GND	-		
F6	GND	-			GND	-		
H10	GND	-			GND	-		
H11	GND	-			GND	-		
H12	GND	-			GND	-		
H13	GND	-			GND	-		
J14	GND	-			GND	-		
J20	GND	-			GND	-		
J3	GND	-			GND	-		
J9	GND	-			GND	-		
K10	GND	-			GND	-		
K11	GND	-			GND	-		
K12	GND	-			GND	-		
K13	GND	-			GND	-		
K15	GND	-			GND	-		
K8	GND	-			GND	-		
L10	GND	-			GND	-		
L11	GND	-			GND	-		
L12	GND	-			GND	-		
L13	GND	-			GND	-		
L15	GND	-			GND	-		

LFE2-12E/SE and LFE2-20E/SE Logic Signal Connections: 484 fpBGA

LFE2-12E/12SE					LFE2-20E/20SE			
Ball Number	Ball/Pad Function	Bank	Dual Function	Differential	Ball/Pad Function	Bank	Dual Function	Differential
L8	GND	-			GND	-		
M10	GND	-			GND	-		
M11	GND	-			GND	-		
M12	GND	-			GND	-		
M13	GND	-			GND	-		
M15	GND	-			GND	-		
M8	GND	-			GND	-		
N10	GND	-			GND	-		
N11	GND	-			GND	-		
N12	GND	-			GND	-		
N13	GND	-			GND	-		
N15	GND	-			GND	-		
N8	GND	-			GND	-		
P14	GND	-			GND	-		
P20	GND	-			GND	-		
P3	GND	-			GND	-		
P9	GND	-			GND	-		
R10	GND	-			GND	-		
R11	GND	-			GND	-		
R12	GND	-			GND	-		
R13	GND	-			GND	-		
U17	GND	-			GND	-		
U6	GND	-			GND	-		
W2	GND	-			GND	-		
W21	GND	-			GND	-		
Y14	GND	-			GND	-		
Y9	GND	-			GND	-		
H6	NC	-			NC	-		
J6	NC	-			NC	-		
H3	NC	-			NC	-		
H2	NC	-			NC	-		
H17	NC	-			NC	-		
H16	NC	-			NC	-		
H20	NC	-			NC	-		
H18	NC	-			NC	-		
K6	NC	-			NC	-		
J16	NC	-			NC	-		
N18	VCC	-			VCC	-		
N6	VCC	-			VCC	-		

* Supports true LVDS. Other differential signals must be emulated with external resistors.

** These dedicated input pins can be used for GPLLs or GDLLs within the respective quadrant.

Note: VCCIO and GND pads are used to determine the average DC current drawn by I/Os between GND/VCCIO connections, or between the last GND/VCCIO in an I/O bank and the end of an I/O bank. The substrate pads listed in the Pin Table do not necessarily have a one to one connection with a package ball or pin.

LFE2-35E/SE and LFE2-50E/SE Logic Signal Connections: 484 fpBGA

LFE2-35E/SE					LFE2-50E/SE			
Ball Number	Ball/Pad Function	Bank	Dual Function	Differential	Ball/Pad Function	Bank	Dual Function	Differential
E4	PL2A	7	VREF2_7/LDQ6	T (LVDS)*	PL2A	7	VREF2_7	T (LVDS)*
E5	PL2B	7	VREF1_7/LDQ6	C (LVDS)*	PL2B	7	VREF1_7	C (LVDS)*
VCCIO	VCCIO7	-			GNDIO7	-		
GNDIO	GNDIO7	-			VCCIO	7		
E3	PL10A	7	LDQ14	T (LVDS)*	PL12A	7	LDQ16	T (LVDS)*
F3	PL10B	7	LDQ14	C (LVDS)*	PL12B	7	LDQ16	C (LVDS)*
F4	PL11A	7	LDQ14	T	PL13A	7	LDQ16	T
F5	PL11B	7	LDQ14	C	PL13B	7	LDQ16	C
E2	PL12A	7	LDQ14	T (LVDS)*	PL14A	7	LDQ16	T (LVDS)*
VCCIO	VCCIO7	7			VCCIO	7		
E1	PL12B	7	LDQ14	C (LVDS)*	PL14B	7	LDQ16	C (LVDS)*
G6	PL13A	7	LDQ14	T	PL15A	7	LDQ16	T
G7	PL13B	7	LDQ14	C	PL15B	7	LDQ16	C
H4	PL14A	7	LDQS14	T (LVDS)*	PL16A	7	LDQS16	T (LVDS)*
GNDIO	GNDIO7	-			GNDIO7	-		
H5	PL14B	7	LDQ14	C (LVDS)*	PL16B	7	LDQ16	C (LVDS)*
F1	PL15A	7	LDQ14	T	PL17A	7	LDQ16	T
F2	PL15B	7	LDQ14	C	PL17B	7	LDQ16	C
VCCIO	VCCIO7	7			VCCIO	7		
G3	PL16A	7	LDQ14	T (LVDS)*	PL18A	7	LDQ16	T (LVDS)*
G4	PL16B	7	LDQ14	C (LVDS)*	PL18B	7	LDQ16	C (LVDS)*
G1	PL17A	7	LDQ14	T	PL19A	7	LDQ16	T
G2	PL17B	7	LDQ14	C	PL19B	7	LDQ16	C
GNDIO	GNDIO7	-			GNDIO7	-		
-	-	-			VCCIO	7		
H6	NC	-			PL25A	7	LUM0_SPLLT_IN_A/LDQ24	T
-	-	-			VCCIO	7		
J6	NC	-			PL25B	7	LUM0_SPLLC_IN_A/LDQ24	C
H3	NC	-			PL26A	7	LUM0_SPLLT_FB_A/LDQ24	T
H2	NC	-			PL26B	7	LUM0_SPLLC_FB_A/LDQ24	C
-	-	-			GNDIO7	-		
-	-	-			VCCIO	7		
H1	PL18A	7	LDQ22		PL37A	7	LDQ41	
J4	PL19A	7	LDQ22	T	PL38A	7	LDQ41	T
J5	PL19B	7	LDQ22	C	PL38B	7	LDQ41	C
VCCIO	VCCIO7	7			VCCIO	7		
J2	PL20A	7	LDQ22	T (LVDS)*	PL39A	7	LDQ41	T (LVDS)*
J1	PL20B	7	LDQ22	C (LVDS)*	PL39B	7	LDQ41	C (LVDS)*
L6	PL21A	7	LDQ22	T	PL40A	7	LDQ41	T
L5	PL21B	7	LDQ22	C	PL40B	7	LDQ41	C
GNDIO	GNDIO7	-			GNDIO7	-		
K3	PL22A	7	LDQS22	T (LVDS)*	PL41A	7	LDQS41	T (LVDS)*
K4	PL22B	7	LDQ22	C (LVDS)*	PL41B	7	LDQ41	C (LVDS)*
K2	PL23A	7	LDQ22	T	PL42A	7	LDQ41	T
VCCIO	VCCIO7	7			VCCIO	7		
K1	PL23B	7	LDQ22	C	PL42B	7	LDQ41	C
L4	PL24A	7	LDQ22	T (LVDS)*	PL43A	7	LDQ41	T (LVDS)*

LFE2-35E/SE and LFE2-50E/SE Logic Signal Connections: 484 fpBGA

LFE2-35E/SE					LFE2-50E/SE			
Ball Number	Ball/Pad Function	Bank	Dual Function	Differential	Ball/Pad Function	Bank	Dual Function	Differential
L3	PL24B	7	LDQ22	C (LVDS)*	PL43B	7	LDQ41	C (LVDS)*
L2	PL25A	7	PCLKT7_0/LDQ22	T	PL44A	7	PCLKT7_0/LDQ41	T
GNDIO	GNDIO7	-			GNDIO7	-		
L1	PL25B	7	PCLKC7_0/LDQ22	C	PL44B	7	PCLKC7_0/LDQ41	C
M5	PL27A	6	PCLKT6_0/LDQ31	T (LVDS)*	PL46A	6	PCLKT6_0/LDQ50	T (LVDS)*
M6	PL27B	6	PCLKC6_0/LDQ31	C (LVDS)*	PL46B	6	PCLKC6_0/LDQ50	C (LVDS)*
M3	PL28A	6	VREF2_6/LDQ31	T	PL47A	6	VREF2_6/LDQ50	T
M4	PL28B	6	VREF1_6/LDQ31	C	PL47B	6	VREF1_6/LDQ50	C
M2	PL29A	6	LDQ31	T (LVDS)*	PL48A	6	LDQ50	T (LVDS)*
VCCIO	VCCIO6	6			VCCIO	6		
M1	PL29B	6	LDQ31	C (LVDS)*	PL48B	6	LDQ50	C (LVDS)*
N1	PL30A	6	LDQ31	T	PL49A	6	LDQ50	T
N2	PL30B	6	LDQ31	C	PL49B	6	LDQ50	C
GNDIO	GNDIO6	-			GNDIO6	-		
VCCIO	VCCIO6	6			VCCIO	6		
N3	PL39A	6	LDQS39***	T (LVDS)*	PL58A	6	LDQS58***	T (LVDS)*
N4	PL39B	6	LDQ39	C (LVDS)*	PL58B	6	LDQ58	C (LVDS)*
N5	PL40A	6	LDQ39	T	PL59A	6	LDQ58	T
VCCIO	VCCIO6	6			VCCIO	6		
P5	PL40B	6	LDQ39	C	PL59B	6	LDQ58	C
P1	PL41A	6	LLM0_GDLLT_IN_A**/LDQ39	T (LVDS)*	PL60A	6	LLM0_GDLLT_IN_A**/LDQ58	T (LVDS)*
P2	PL41B	6	LLM0_GDLLC_IN_A**/LDQ39	C (LVDS)*	PL60B	6	LLM0_GDLLC_IN_A**/LDQ58	C (LVDS)*
P4	PL42A	6	LLM0_GDLLT_FB_A/LDQ39	T	PL61A	6	LLM0_GDLLT_FB_A/LDQ58	T
GNDIO	GNDIO6	-			GNDIO6	-		
R4	PL42B	6	LLM0_GDLLC_FB_A/LDQ39	C	PL61B	6	LLM0_GDLLC_FB_D/LDQ58	C
P6	LLM0_PLLCAP	6			LLM0_PLLCAP	6		
R1	PL44A	6	LLM0_GPLLT_IN_A**/LDQ48	T (LVDS)*	PL63A	6	LLM0_GPLLT_IN_A**/LDQ67	T (LVDS)*
R2	PL44B	6	LLM0_GPLLC_IN_A**/LDQ48	C (LVDS)*	PL63B	6	LLM0_GPLLC_IN_A**/LDQ67	C (LVDS)*
R3	PL45A	6	LLM0_GPLLT_FB_A/LDQ48	T	PL64A	6	LLM0_GPLLT_FB_A/LDQ67	T
T4	PL45B	6	LLM0_GPLLC_FB_A/LDQ48	C	PL64B	6	LLM0_GPLLC_FB_A/LDQ67	C
T1	PL46A	6	LDQ48	T (LVDS)*	PL65A	6	LDQ67	T (LVDS)*
VCCIO	VCCIO6	6			VCCIO	6		
T2	PL46B	6	LDQ48	C (LVDS)*	PL65B	6	LDQ67	C (LVDS)*
T5	PL47A	6	LDQ48	T	PL66A	6	LDQ67	T
T3	PL47B	6	LDQ48	C	PL66B	6	LDQ67	C
GNDIO	GNDIO6	-			VCCIO	6		
VCCIO	VCCIO6	-			GNDIO6	-		
U1	PL52A	6	LDQ56	T (LVDS)*	PL71A	6	LDQ75	T (LVDS)*
U2	PL52B	6	LDQ56	C (LVDS)*	PL71B	6	LDQ75	C (LVDS)*
V1	PL53A	6	LDQ56	T	PL72A	6	LDQ75	T
V2	PL53B	6	LDQ56	C	PL72B	6	LDQ75	C
VCCIO	VCCIO6	6			VCCIO	6		
R6	PL54A	6	LDQ56	T (LVDS)*	PL73A	6	LDQ75	T (LVDS)*
T6	PL54B	6	LDQ56	C (LVDS)*	PL73B	6	LDQ75	C (LVDS)*
U3	PL55A	6	LDQ56	T	PL74A	6	LDQ75	T
U4	PL55B	6	LDQ56	C	PL74B	6	LDQ75	C
GNDIO	GNDIO6	-			GNDIO6	-		

LFE2-35E/SE and LFE2-50E/SE Logic Signal Connections: 484 fpBGA

LFE2-35E/SE					LFE2-50E/SE			
Ball Number	Ball/Pad Function	Bank	Dual Function	Differential	Ball/Pad Function	Bank	Dual Function	Differential
Y1	PL56A	6	LDQS56	T (LVDS)*	PL75A	6	LDQS75	T (LVDS)*
W1	PL56B	6	LDQ56	C (LVDS)*	PL75B	6	LDQ75	C (LVDS)*
R7	PL57A	6	LDQ56	T	PL76A	6	LDQ75	T
VCCIO	VCCIO6	6			VCCIO	6		
T7	PL57B	6	LDQ56	C	PL76B	6	LDQ75	C
V4	PL58A	6	LDQ56	T (LVDS)*	PL77A	6	LDQ75	T (LVDS)*
V3	PL58B	6	LDQ56	C (LVDS)*	PL77B	6	LDQ75	C (LVDS)*
AA2	PL59A	6	LDQ56	T	PL78A	6	LDQ75	T
GNDIO	GNDIO6	-			GNDIO6	-		
AA1	PL59B	6	LDQ56	C	PL78B	6	LDQ75	C
U7	TCK	-			TCK	-		
U5	TDI	-			TDI	-		
V5	TMS	-			TMS	-		
V6	TDO	-			TDO	-		
T8	VCCJ	-			VCCJ	-		
Y3	PB2A	5	VREF2_5/BDQ6	T	PB2A	5	VREF2_5/BDQ6	T
Y2	PB2B	5	VREF1_5/BDQ6	C	PB2B	5	VREF1_5/BDQ6	C
W4	PB3A	5	BDQ6	T	PB3A	5	BDQ6	T
W3	PB3B	5	BDQ6	C	PB3B	5	BDQ6	C
W5	PB4A	5	BDQ6	T	PB4A	5	BDQ6	T
W6	PB4B	5	BDQ6	C	PB4B	5	BDQ6	C
VCCIO	VCCIO5	5			VCCIO	5		
AB3	PB5A	5	BDQ6	T	PB5A	5	BDQ6	T
AB2	PB5B	5	BDQ6	C	PB5B	5	BDQ6	C
GNDIO	GNDIO5	-			GNDIO5	-		
Y4	PB6A	5	BDQS6	T	PB6A	5	BDQS6	T
AA3	PB6B	5	BDQ6	C	PB6B	5	BDQ6	C
AB5	PB7A	5	BDQ6	T	PB7A	5	BDQ6	T
AB4	PB7B	5	BDQ6	C	PB7B	5	BDQ6	C
AA5	PB8A	5	BDQ6	T	PB8A	5	BDQ6	T
Y5	PB8B	5	BDQ6	C	PB8B	5	BDQ6	C
VCCIO	VCCIO5	5			VCCIO	5		
AB6	PB9A	5	BDQ6	T	PB9A	5	BDQ6	T
AA6	PB9B	5	BDQ6	C	PB9B	5	BDQ6	C
GNDIO	GNDIO5	-			GNDIO5	-		
VCCIO	VCCIO5	5			VCCIO	5		
W7	PB20A	5	BDQ24	T	PB29A	5	BDQ33	T
W8	PB20B	5	BDQ24	C	PB29B	5	BDQ33	C
Y6	PB21A	5	BDQ24	T	PB30A	5	BDQ33	T
Y7	PB21B	5	BDQ24	C	PB30B	5	BDQ33	C
AA7	PB22A	5	BDQ24	T	PB31A	5	BDQ33	T
VCCIO	VCCIO5	5			VCCIO	5		
AB7	PB22B	5	BDQ24	C	PB31B	5	BDQ33	C
U8	PB23A	5	BDQ24	T	PB32A	5	BDQ33	T
U9	PB23B	5	BDQ24	C	PB32B	5	BDQ33	C
W9	PB24A	5	BDQS24	T	PB33A	5	BDQS33	T
GNDIO	GNDIO5	-			GNDIO5	-		

LFE2-35E/SE and LFE2-50E/SE Logic Signal Connections: 484 fpBGA

LFE2-35E/SE					LFE2-50E/SE				
Ball Number	Ball/Pad Function	Bank	Dual Function	Differential	Ball/Pad Function	Bank	Dual Function	Differential	
V9	PB24B	5	BDQ24	C	PB33B	5	BDQ33	C	
Y8	PB25A	5	BDQ24	T	PB34A	5	BDQ33	T	
AA8	PB25B	5	BDQ24	C	PB34B	5	BDQ33	C	
W10	PB26A	5	BDQ24	T	PB35A	5	BDQ33	T	
VCCIO	VCCIO5	5			VCCIO	5			
V10	PB26B	5	BDQ24	C	PB35B	5	BDQ33	C	
AB8	PB27A	5	BDQ24	T	PB36A	5	BDQ33	T	
AA9	PB27B	5	BDQ24	C	PB36B	5	BDQ33	C	
GNDIO	GNDIO5	-			GNDIO5	-			
AB9	PB29A	5	BDQ33	T	PB38A	5	BDQ42	T	
AB10	PB29B	5	BDQ33	C	PB38B	5	BDQ42	C	
Y10	PB30A	5	BDQ33	T	PB39A	5	BDQ42	T	
AA10	PB30B	5	BDQ33	C	PB39B	5	BDQ42	C	
U10	PB31A	5	BDQ33	T	PB40A	5	BDQ42	T	
U11	PB31B	5	BDQ33	C	PB40B	5	BDQ42	C	
VCCIO	VCCIO5	5			VCCIO	5			
AB11	PB32A	5	BDQ33	T	PB41A	5	BDQ42	T	
AA11	PB32B	5	BDQ33	C	PB41B	5	BDQ42	C	
GNDIO	GNDIO5	-			GNDIO5	-			
Y11	PB33A	5	BDQS33	T	PB42A	5	BDQS42	T	
W11	PB33B	5	BDQ33	C	PB42B	5	BDQ42	C	
AB12	PB34A	5	BDQ33	T	PB43A	5	BDQ42	T	
AA12	PB34B	5	BDQ33	C	PB43B	5	BDQ42	C	
AB13	PB35A	5	PCLKT5_0/BDQ33	T	PB44A	5	PCLKT5_0/BDQ42	T	
AB14	PB35B	5	PCLKC5_0/BDQ33	C	PB44B	5	PCLKC5_0/BDQ42	C	
VCCIO	VCCIO5	5			VCCIO	5			
GNDIO	GNDIO5	-			GNDIO5	-			
U12	PB40A	4	PCLKT4_0/BDQ42	T	PB49A	4	PCLKT4_0/BDQ51	T	
VCCIO	VCCIO4	4			VCCIO	4			
V12	PB40B	4	PCLKC4_0/BDQ42	C	PB49B	4	PCLKC4_0/BDQ51	C	
Y12	PB41A	4	BDQ42	T	PB50A	4	BDQ51	T	
W12	PB41B	4	BDQ42	C	PB50B	4	BDQ51	C	
AA13	PB42A	4	BDQS42	T	PB51A	4	BDQS51	T	
GNDIO	GNDIO4	-			GNDIO4	-			
Y13	PB42B	4	BDQ42	C	PB51B	4	BDQ51	C	
U13	PB43A	4	BDQ42	T	PB52A	4	BDQ51	T	
U14	PB43B	4	BDQ42	C	PB52B	4	BDQ51	C	
AB15	PB44A	4	BDQ42	T	PB53A	4	BDQ51	T	
VCCIO	VCCIO4	4			VCCIO	4			
AA14	PB44B	4	BDQ42	C	PB53B	4	BDQ51	C	
AB16	PB45A	4	BDQ42	T	PB54A	4	BDQ51	T	
AB17	PB45B	4	BDQ42	C	PB54B	4	BDQ51	C	
W13	PB46A	4	BDQ42	T	PB55A	4	BDQ51	T	
GNDIO	GNDIO4	-			GNDIO4	-			
W14	PB46B	4	BDQ42	C	PB55B	4	BDQ51	C	
AB18	PB48A	4	BDQ51	T	PB57A	4	BDQ60	T	
AB19	PB48B	4	BDQ51	C	PB57B	4	BDQ60	C	

LFE2-35E/SE and LFE2-50E/SE Logic Signal Connections: 484 fpBGA

LFE2-35E/SE					LFE2-50E/SE				
Ball Number	Ball/Pad Function	Bank	Dual Function	Differential	Ball/Pad Function	Bank	Dual Function	Differential	
V14	PB49A	4	BDQ51	T	PB58A	4	BDQ60	T	
W15	PB49B	4	BDQ51	C	PB58B	4	BDQ60	C	
VCCIO	VCCIO4	4			VCCIO	4			
Y15	PB50A	4	BDQ51	T	PB59A	4	BDQ60	T	
AA15	PB50B	4	BDQ51	C	PB59B	4	BDQ60	C	
GNDIO	GNDIO4	-			GNDIO4	-			
AA16	PB51A	4	BDQS51	T	PB60A	4	BDQS60	T	
AA17	PB51B	4	BDQ51	C	PB60B	4	BDQ60	C	
AB20	PB52A	4	BDQ51	T	PB61A	4	BDQ60	T	
AB21	PB52B	4	BDQ51	C	PB61B	4	BDQ60	C	
U15	PB53A	4	BDQ51	T	PB62A	4	BDQ60	T	
U16	PB53B	4	BDQ51	C	PB62B	4	BDQ60	C	
VCCIO	VCCIO4	4			VCCIO	4			
Y16	PB54A	4	BDQ51	T	PB63A	4	BDQ60	T	
W16	PB54B	4	BDQ51	C	PB63B	4	BDQ60	C	
AA18	PB55A	4	BDQ51	T	PB64A	4	BDQ60	T	
AA20	PB55B	4	BDQ51	C	PB64B	4	BDQ60	C	
GNDIO	GNDIO4	-			GNDIO4	-			
VCCIO	VCCIO4	4			VCCIO	4			
AA21	PB66A	4	BDQ69	T	PB75A	4	BDQ78	T	
AA22	PB66B	4	BDQ69	C	PB75B	4	BDQ78	C	
V16	PB67A	4	BDQ69	T	PB76A	4	BDQ78	T	
V17	PB67B	4	BDQ69	C	PB76B	4	BDQ78	C	
VCCIO	VCCIO4	4			VCCIO	4			
Y18	PB68A	4	BDQ69	T	PB77A	4	BDQ78	T	
Y17	PB68B	4	BDQ69	C	PB77B	4	BDQ78	C	
GNDIO	GNDIO4	-			GNDIO4	-			
Y19	PB69A	4	BDQS69	T	PB78A	4	BDQS78	T	
Y20	PB69B	4	BDQ69	C	PB78B	4	BDQ78	C	
W17	PB70A	4	BDQ69	T	PB79A	4	BDQ78	T	
W18	PB70B	4	BDQ69	C	PB79B	4	BDQ78	C	
Y21	PB71A	4	BDQ69	T	PB80A	4	BDQ78	T	
Y22	PB71B	4	BDQ69	C	PB80B	4	BDQ78	C	
VCCIO	VCCIO4	4			VCCIO	4			
U18	PB72A	4	BDQ69	T	PB81A	4	BDQ78	T	
V18	PB72B	4	BDQ69	C	PB81B	4	BDQ78	C	
T15	PB73A	4	VREF2_4/BDQ69	T	PB82A	4	VREF2_4/BDQ78	T	
T16	PB73B	4	VREF1_4/BDQ69	C	PB82B	4	VREF1_4/BDQ78	C	
GNDIO	GNDIO4	-			GNDIO4	-			
W19	CFG2	8			CFG2	8			
V19	CFG1	8			CFG1	8			
W20	CFG0	8			CFG0	8			
V20	PROGRAMN	8			PROGRAMN	8			
W22	CCLK	8			CCLK	8			
V22	INITN	8			INITN	8			
V21	DONE	8			DONE	8			
GNDIO	GNDIO8	-			GNDIO8	-			

LFE2-35E/SE and LFE2-50E/SE Logic Signal Connections: 484 fpBGA

LFE2-35E/SE					LFE2-50E/SE			
Ball Number	Ball/Pad Function	Bank	Dual Function	Differential	Ball/Pad Function	Bank	Dual Function	Differential
R16	PR58B	8	WRITEN	C	PR77B	8	WRITEN	C
R17	PR58A	8	CS1N	T	PR77A	8	CS1N	T
U19	PR57B	8	CSN	C	PR76B	8	CSN	C
U20	PR57A	8	D0/SPIFASTN	T	PR76A	8	D0/SPIFASTN	T
VCCIO	VCCIO8	8			VCCIO	8		
U22	PR56B	8	D1	C	PR75B	8	D1	C
U21	PR56A	8	D2	T	PR75A	8	D2	T
T20	PR55B	8	D3	C	PR74B	8	D3	C
GNDIO	GNDIO8	-			GNDIO8	-		
T19	PR55A	8	D4	T	PR74A	8	D4	T
T17	PR54B	8	D5	C	PR73B	8	D5	C
T18	PR54A	8	D6	T	PR73A	8	D6	T
T21	PR53B	8	D7	C	PR72B	8	D7	C
VCCIO	VCCIO8	8			VCCIO	8		
T22	PR53A	8	DI/CSSPION	T	PR72A	8	DI/CSSPION	T
R18	PR52B	8	DOUT/CSON	C	PR71B	8	DOUT/CSON	C
R19	PR52A	8	BUSY/SISPI	T	PR71A	8	BUSY/SISPI	T
GNDIO	GNDIO3	-			GNDIO3	-		
VCCIO	VCCIO3	3			VCCIO	3		
R22	PR47B	3	RDQ48	C	PR66B	3	RDQ67	C
R21	PR47A	3	RDQ48	T	PR66A	3	RDQ67	T
P18	PR46B	3	RDQ48	C (LVDS)*	PR65B	3	RDQ67	C (LVDS)*
P19	PR46A	3	RDQ48	T (LVDS)*	PR65A	3	RDQ67	T (LVDS)*
VCCIO	VCCIO3	3			VCCIO	3		
R20	PR45B	3	RLM0_GPLL_CFB_A/RDQ48	C	PR64B	3	RLM0_GPLL_CFB_A/RDQ67	C
P22	PR45A	3	RLM0_GPLLT_CFB_A/RDQ48	T	PR64A	3	RLM0_GPLLT_CFB_A/RDQ67	T
P21	PR44B	3	RLM0_GPLL_IN_A**/RDQ48	C (LVDS)*	PR63B	3	RLM0_GPLL_IN_A**/RDQ67	C (LVDS)*
N21	PR44A	3	RLM0_GPLLT_IN_A**/RDQ48	T (LVDS)*	PR63A	3	RLM0_GPLLT_IN_A**/RDQ67	T (LVDS)*
N17	RLM0_PLLCAP	3			RLM0_PLLCAP	3		
N22	PR42B	3	RLM0_GDLL_CFB_A/RDQ39	C	PR61B	3	RLM0_GDLL_CFB_A/RDQ58	C
N20	PR42A	3	RLM0_GDLLT_CFB_A/RDQ39	T	PR61A	3	RLM0_GDLLT_CFB_A/RDQ58	T
GNDIO	GNDIO3	-			GNDIO3	-		
M22	PR41B	3	RLM0_GDLL_IN_A**/RDQ39	C (LVDS)*	PR60B	3	RLM0_GDLL_IN_A**/RDQ58	C (LVDS)*
M21	PR41A	3	RLM0_GDLLT_IN_A**/RDQ39	T (LVDS)*	PR60A	3	RLM0_GDLLT_IN_A**/RDQ58	T (LVDS)*
N19	PR40B	3	RDQ39	C	PR59B	3	RDQ58	C
M19	PR40A	3	RDQ39	T	PR59A	3	RDQ58	T
VCCIO	VCCIO3	3			VCCIO	3		
GNDIO	GNDIO3	-			GNDIO3	-		
L22	PR30B	3	RDQ31	C	PR49B	3	RDQ50	C
K22	PR30A	3	RDQ31	T	PR49A	3	RDQ50	T
J22	PR29B	3	RDQ31	C (LVDS)*	PR48B	3	RDQ50	C (LVDS)*
H22	PR29A	3	RDQ31	T (LVDS)*	PR48A	3	RDQ50	T (LVDS)*
VCCIO	VCCIO3	3			VCCIO	3		
M20	PR28B	3	VREF2_3/RDQ31	C	PR47B	3	VREF2_3/RDQ50	C
L21	PR28A	3	VREF1_3/RDQ31	T	PR47A	3	VREF1_3/RDQ50	T
K21	PR27B	3	PCLKC3_0/RDQ31	C (LVDS)*	PR46B	3	PCLKC3_0/RDQ50	C (LVDS)*
J21	PR27A	3	PCLKT3_0/RDQ31	T (LVDS)*	PR46A	3	PCLKT3_0/RDQ50	T (LVDS)*

LFE2-35E/SE and LFE2-50E/SE Logic Signal Connections: 484 fpBGA

LFE2-35E/SE					LFE2-50E/SE			
Ball Number	Ball/Pad Function	Bank	Dual Function	Differential	Ball/Pad Function	Bank	Dual Function	Differential
M18	PR25B	2	PCLKC2_0/RDQ22	C	PR44B	2	PCLKC2_0/RDQ41	C
L17	PR25A	2	PCLKT2_0/RDQ22	T	PR44A	2	PCLKT2_0/RDQ41	T
GNDIO	GNDIO2	-			GNDIO2	-		
L19	PR24B	2	RDQ22	C (LVDS)*	PR43B	2	RDQ41	C (LVDS)*
L20	PR24A	2	RDQ22	T (LVDS)*	PR43A	2	RDQ41	T (LVDS)*
L18	PR23B	2	RDQ22	C	PR42B	2	RDQ41	C
K17	PR23A	2	RDQ22	T	PR42A	2	RDQ41	T
VCCIO	VCCIO2	2			VCCIO	2		
K18	PR22B	2	RDQ22	C (LVDS)*	PR41B	2	RDQ41	C (LVDS)*
K19	PR22A	2	RDQS22	T (LVDS)*	PR41A	2	RDQS41	T (LVDS)*
G22	PR21B	2	RDQ22	C	PR40B	2	RDQ41	C
GNDIO	GNDIO2	-			GNDIO2	-		
F22	PR21A	2	RDQ22	T	PR40A	2	RDQ41	T
J17	PR20B	2	RDQ22	C (LVDS)*	PR39B	2	RDQ41	C (LVDS)*
J18	PR20A	2	RDQ22	T (LVDS)*	PR39A	2	RDQ41	T (LVDS)*
K20	PR19B	2	RDQ22	C	PR38B	2	RDQ41	C
VCCIO	VCCIO2	2			VCCIO	2		
J19	PR19A	2	RDQ22	T	PR38A	2	RDQ41	T
H21	PR18B	2	RDQ22	C (LVDS)*	PR37B	2	RDQ41	C (LVDS)*
G21	PR18A	2	RDQ22	T (LVDS)*	PR37A	2	RDQ41	T (LVDS)*
-	-	-			GNDIO2	-		
-	-	-			VCCIO	2		
H17	NC	-			PR26B	2	RUM0_SPLLC_FB_A/RDQ24	C
H16	NC	-			PR26A	2	RUM0_SPLLT_FB_A/RDQ24	T
H20	NC	-			PR25B	2	RUM0_SPLLC_IN_A/RDQ24	C
H18	NC	-			PR25A	2	RUM0_SPLLT_IN_A/RDQ24	T
-	-	-			GNDIO2	-		
-	-	-			VCCIO	2		
F21	PR17B	2	RDQ14	C	PR19B	2	RDQ16	C
GNDIO	GNDIO2	-			GNDIO2	-		
E22	PR17A	2	RDQ14	T	PR19A	2	RDQ16	T
D22	PR16B	2	RDQ14	C (LVDS)*	PR18B	2	RDQ16	C (LVDS)*
E21	PR16A	2	RDQ14	T (LVDS)*	PR18A	2	RDQ16	T (LVDS)*
G20	PR15B	2	RDQ14	C	PR17B	2	RDQ16	C
VCCIO	VCCIO2	2			VCCIO	2		
F20	PR15A	2	RDQ14	T	PR17A	2	RDQ16	T
H19	PR14B	2	RDQ14	C (LVDS)*	PR16B	2	RDQ16	C (LVDS)*
G19	PR14A	2	RDQS14	T (LVDS)*	PR16A	2	RDQS16	T (LVDS)*
GNDIO	GNDIO2	-			GNDIO2	-		
G17	PR13B	2	RDQ14	C	PR15B	2	RDQ16	C
F19	PR13A	2	RDQ14	T	PR15A	2	RDQ16	T
E20	PR12B	2	RDQ14	C (LVDS)*	PR14B	2	RDQ16	C (LVDS)*
D20	PR12A	2	RDQ14	T (LVDS)*	PR14A	2	RDQ16	T (LVDS)*
VCCIO	VCCIO2	2			VCCIO	2		
F18	PR11B	2	RDQ14	C	PR13B	2	RDQ16	C
F16	PR11A	2	RDQ14	T	PR13A	2	RDQ16	T
C21	PR10B	2	RDQ14	C (LVDS)*	PR12B	2	RDQ16	C (LVDS)*

LFE2-35E/SE and LFE2-50E/SE Logic Signal Connections: 484 fpBGA

LFE2-35E/SE					LFE2-50E/SE			
Ball Number	Ball/Pad Function	Bank	Dual Function	Differential	Ball/Pad Function	Bank	Dual Function	Differential
C22	PR10A	2	RDQ14	T (LVDS)*	PR12A	2	RDQ16	T (LVDS)*
VCCIO	VCCIO2	2			VCCIO	2		
GNDIO	GNDIO2	-			GNDIO2	-		
D19	PR2B	2	VREF2_2/RDQ6	C (LVDS)*	PR2B	2	VREF2_2	C (LVDS)*
E19	PR2A	2	VREF1_2/RDQ6	T (LVDS)*	PR2A	2	VREF1_2	T (LVDS)*
B21	PT73B	1	VREF2_1	C	PT82B	1	VREF2_1	C
GNDIO	GNDIO1	-			GNDIO1	-		
B22	PT73A	1	VREF1_1	T	PT82A	1	VREF1_1	T
C20	PT72B	1		C	PT81B	1		C
C19	PT72A	1		T	PT81A	1		T
D18	PT71B	1		C	PT80B	1		C
VCCIO	VCCIO1	1			VCCIO	1		
E18	PT71A	1		T	PT80A	1		T
B20	PT70B	1		C	PT79B	1		C
A19	PT70A	1		T	PT79A	1		T
D17	PT69B	1		C	PT78B	1		C
C18	PT69A	1		T	PT78A	1		T
A21	PT68B	1		C	PT77B	1		C
GNDIO	GNDIO1	-			GNDIO1	-		
A20	PT68A	1		T	PT77A	1		T
A18	PT67B	1		C	PT76B	1		C
VCCIO	VCCIO1	1			VCCIO	1		
B18	PT67A	1		T	PT76A	1		T
G16	PT66B	1		C	PT75B	1		C
G15	PT66A	1		T	PT75A	1		T
D16	PT65B	1		C	PT74B	1		C
E16	PT65A	1		T	PT74A	1		T
GNDIO	GNDIO1	-			GNDIO1	-		
VCCIO	VCCIO1	1			VCCIO	1		
C17	PT55B	1		C	PT64B	1		C
GNDIO	GNDIO1	-			GNDIO1	-		
C16	PT55A	1		T	PT64A	1		T
B17	PT54B	1		C	PT63B	1		C
B16	PT54A	1		T	PT63A	1		T
A17	PT53B	1		C	PT62B	1		C
VCCIO	VCCIO1	1			VCCIO	1		
A16	PT53A	1		T	PT62A	1		T
C15	PT52B	1		C	PT61B	1		C
D15	PT52A	1		T	PT61A	1		T
E15	PT51B	1		C	PT60B	1		C
F15	PT51A	1		T	PT60A	1		T
GNDIO	GNDIO1	-			GNDIO1	-		
B15	PT49B	1		C	PT58B	1		C
VCCIO	VCCIO1	1			VCCIO	1		
A15	PT49A	1		T	PT58A	1		T
B14	PT48B	1		C	PT57B	1		C
A14	PT48A	1		T	PT57A	1		T

LFE2-35E/SE and LFE2-50E/SE Logic Signal Connections: 484 fpBGA

LFE2-35E/SE					LFE2-50E/SE			
Ball Number	Ball/Pad Function	Bank	Dual Function	Differential	Ball/Pad Function	Bank	Dual Function	Differential
D14	PT46B	1		C	PT55B	1		C
C13	PT46A	1		T	PT55A	1		T
GNDIO	GNDIO1	-			GNDIO1	-		
E14	PT45B	1		C	PT54B	1		C
F14	PT45A	1		T	PT54A	1		T
A13	PT44B	1		C	PT53B	1		C
B13	PT44A	1		T	PT53A	1		T
VCCIO	VCCIO1	1			VCCIO	1		
E13	PT43B	1		C	PT52B	1		C
D13	PT43A	1		T	PT52A	1		T
E12	PT42B	1		C	PT51B	1		C
D12	PT42A	1		T	PT51A	1		T
GNDIO	GNDIO1	-			GNDIO1	-		
A12	PT40B	1		C	PT49B	1		C
A11	PT40A	1		T	PT49A	1		T
VCCIO	VCCIO1	1			VCCIO	1		
B12	PT39B	1	PCLKC1_0	C	PT48B	1	PCLKC1_0	C
C12	PT39A	1	PCLKT1_0	T	PT48A	1	PCLKT1_0	T
F12	XRES	1			XRES	1		
B10	PT37B	0	PCLKC0_0	C	PT46B	0	PCLKC0_0	C
GNDIO	GNDIO0	-			GNDIO0	0		
B11	PT37A	0	PCLKT0_0	T	PT46A	0	PCLKT0_0	T
A10	PT36B	0		C	PT45B	0		C
A9	PT36A	0		T	PT45A	0		T
C11	PT35B	0		C	PT44B	0		C
VCCIO	VCCIO0	0			VCCIO	0		
C10	PT35A	0		T	PT44A	0		T
E11	PT34B	0		C	PT43B	0		C
F11	PT34A	0		T	PT43A	0		T
A8	PT33B	0		C	PT42B	0		C
A7	PT33A	0		T	PT42A	0		T
B8	PT32B	0		C	PT41B	0		C
GNDIO	GNDIO0	-			GNDIO0	0		
B9	PT32A	0		T	PT41A	0		T
VCCIO	VCCIO0	0			VCCIO	0		
B7	PT30B	0		C	PT39B	0		C
A6	PT30A	0		T	PT39A	0		T
C8	PT29B	0		C	PT38B	0		C
D8	PT29A	0		T	PT38A	0		T
GNDIO	GNDIO0	-			GNDIO0	0		
D10	PT27B	0		C	PT36B	0		C
E10	PT27A	0		T	PT36A	0		T
C7	PT26B	0		C	PT35B	0		C
C6	PT26A	0		T	PT35A	0		T
VCCIO	VCCIO0	0			VCCIO	0		
B6	PT25B	0		C	PT34B	0		C
B5	PT25A	0		T	PT34A	0		T

LFE2-35E/SE and LFE2-50E/SE Logic Signal Connections: 484 fpBGA

LFE2-35E/SE					LFE2-50E/SE			
Ball Number	Ball/Pad Function	Bank	Dual Function	Differential	Ball/Pad Function	Bank	Dual Function	Differential
F10	PT24B	0		C	PT33B	0		C
D9	PT24A	0		T	PT33A	0		T
GNDIO	GNDIO0	-			GNDIO0	0		
F9	PT23B	0		C	PT32B	0		C
E9	PT23A	0		T	PT32A	0		T
A5	PT22B	0		C	PT31B	0		C
A4	PT22A	0		T	PT31A	0		T
VCCIO	VCCIO0	0			VCCIO	0		
A3	PT21B	0		C	PT30B	0		C
A2	PT21A	0		T	PT30A	0		T
G8	PT20B	0		C	PT29B	0		C
E8	PT20A	0		T	PT29A	0		T
GNDIO	GNDIO0	-			GNDIO0	0		
VCCIO	VCCIO0	0			VCCIO	0		
C3	PT10B	0		C	PT10B	0		C
B3	PT10A	0		T	PT10A	0		T
GNDIO	GNDIO0	-			GNDIO0	0		
F8	PT9B	0		C	PT9B	0		C
D7	PT9A	0		T	PT9A	0		T
E7	PT8B	0		C	PT8B	0		C
VCCIO	VCCIO0	0			VCCIO	0		
F7	PT8A	0		T	PT8A	0		T
D5	PT7B	0		C	PT7B	0		C
D6	PT7A	0		T	PT7A	0		T
D4	PT6B	0		C	PT6B	0		C
C4	PT6A	0		T	PT6A	0		T
GNDIO	GNDIO0	-			GNDIO0	0		
B2	PT5B	0		C	PT5B	0		C
B1	PT5A	0		T	PT5A	0		T
J7	PT4B	0		C	PT4B	0		C
VCCIO	VCCIO0	0			VCCIO	0		
H7	PT4A	0		T	PT4A	0		T
D3	PT3B	0		C	PT3B	0		C
C2	PT3A	0		T	PT3A	0		T
D1	PT2B	0	VREF2_0	C	PT2B	0	VREF2_0	C
C1	PT2A	0	VREF1_0	T	PT2A	0	VREF1_0	T
J10	VCC	-			VCC	-		
J11	VCC	-			VCC	-		
J12	VCC	-			VCC	-		
J13	VCC	-			VCC	-		
K14	VCC	-			VCC	-		
K9	VCC	-			VCC	-		
L14	VCC	-			VCC	-		
L9	VCC	-			VCC	-		
M14	VCC	-			VCC	-		
M9	VCC	-			VCC	-		
N14	VCC	-			VCC	-		

LFE2-35E/SE and LFE2-50E/SE Logic Signal Connections: 484 fpBGA

LFE2-35E/SE					LFE2-50E/SE			
Ball Number	Ball/Pad Function	Bank	Dual Function	Differential	Ball/Pad Function	Bank	Dual Function	Differential
N9	VCC	-			VCC	-		
P10	VCC	-			VCC	-		
P11	VCC	-			VCC	-		
P12	VCC	-			VCC	-		
P13	VCC	-			VCC	-		
G5	VCCAUX	-			VCCAUX	0		
K5	VCCAUX	-			VCCAUX	0		
R5	VCCAUX	-			VCCAUX	1		
V7	VCCAUX	-			VCCAUX	1		
V11	VCCAUX	-			VCCAUX	2		
V8	VCCAUX	-			VCCAUX	2		
V13	VCCAUX	-			VCCAUX	3		
V15	VCCAUX	-			VCCAUX	3		
M17	VCCAUX	-			VCCAUX	4		
P17	VCCAUX	-			VCCAUX	4		
E17	VCCAUX	-			VCCAUX	5		
G18	VCCAUX	-			VCCAUX	5		
D11	VCCAUX	-			VCCAUX	6		
F13	VCCAUX	-			VCCAUX	6		
C5	VCCAUX	-			VCCAUX	7		
E6	VCCAUX	-			VCCAUX	7		
G10	VCCIO0	0			VCCIO0	0		
G9	VCCIO0	0			VCCIO0	0		
H8	VCCIO0	0			VCCIO0	0		
H9	VCCIO0	0			VCCIO0	0		
G11	VCCIO1	1			VCCIO1	1		
G12	VCCIO1	1			VCCIO1	1		
G13	VCCIO1	1			VCCIO1	1		
G14	VCCIO1	1			VCCIO1	1		
H14	VCCIO2	2			VCCIO2	2		
H15	VCCIO2	2			VCCIO2	2		
J15	VCCIO2	2			VCCIO2	2		
K16	VCCIO2	2			VCCIO2	2		
L16	VCCIO3	3			VCCIO3	3		
M16	VCCIO3	3			VCCIO3	3		
N16	VCCIO3	3			VCCIO3	3		
P16	VCCIO3	3			VCCIO3	3		
R14	VCCIO4	4			VCCIO4	4		
T12	VCCIO4	4			VCCIO4	4		
T13	VCCIO4	4			VCCIO4	4		
T14	VCCIO4	4			VCCIO4	4		
R9	VCCIO5	5			VCCIO5	5		
T10	VCCIO5	5			VCCIO5	5		
T11	VCCIO5	5			VCCIO5	5		
T9	VCCIO5	5			VCCIO5	5		
N7	VCCIO6	6			VCCIO6	6		
P7	VCCIO6	6			VCCIO6	6		

LFE2-35E/SE and LFE2-50E/SE Logic Signal Connections: 484 fpBGA

LFE2-35E/SE					LFE2-50E/SE			
Ball Number	Ball/Pad Function	Bank	Dual Function	Differential	Ball/Pad Function	Bank	Dual Function	Differential
P8	VCCIO6	6			VCCIO6	6		
R8	VCCIO6	6			VCCIO6	6		
J8	VCCIO7	7			VCCIO7	7		
K7	VCCIO7	7			VCCIO7	7		
L7	VCCIO7	7			VCCIO7	7		
M7	VCCIO7	7			VCCIO7	7		
P15	VCCIO8	8			VCCIO8	8		
R15	VCCIO8	8			VCCIO8	8		
A22	GND	-			GND	-		
AA19	GND	-			GND	-		
AA4	GND	-			GND	-		
AB1	GND	-			GND	-		
AB22	GND	-			GND	-		
B19	GND	-			GND	-		
B4	GND	-			GND	-		
C14	GND	-			GND	-		
C9	GND	-			GND	-		
D2	GND	-			GND	-		
D21	GND	-			GND	-		
F17	GND	-			GND	-		
F6	GND	-			GND	-		
H10	GND	-			GND	-		
H11	GND	-			GND	-		
H12	GND	-			GND	-		
H13	GND	-			GND	-		
J14	GND	-			GND	-		
J20	GND	-			GND	-		
J3	GND	-			GND	-		
J9	GND	-			GND	-		
K10	GND	-			GND	-		
K11	GND	-			GND	-		
K12	GND	-			GND	-		
K13	GND	-			GND	-		
K15	GND	-			GND	-		
K8	GND	-			GND	-		
L10	GND	-			GND	-		
L11	GND	-			GND	-		
L12	GND	-			GND	-		
L13	GND	-			GND	-		
L15	GND	-			GND	-		
L8	GND	-			GND	-		
M10	GND	-			GND	-		
M11	GND	-			GND	-		
M12	GND	-			GND	-		
M13	GND	-			GND	-		
M15	GND	-			GND	-		
M8	GND	-			GND	-		

LFE2-35E/SE and LFE2-50E/SE Logic Signal Connections: 484 fpBGA

LFE2-35E/SE					LFE2-50E/SE			
Ball Number	Ball/Pad Function	Bank	Dual Function	Differential	Ball/Pad Function	Bank	Dual Function	Differential
N10	GND	-			GND	-		
N11	GND	-			GND	-		
N12	GND	-			GND	-		
N13	GND	-			GND	-		
N15	GND	-			GND	-		
N8	GND	-			GND	-		
P14	GND	-			GND	-		
P20	GND	-			GND	-		
P3	GND	-			GND	-		
P9	GND	-			GND	-		
R10	GND	-			GND	-		
R11	GND	-			GND	-		
R12	GND	-			GND	-		
R13	GND	-			GND	-		
U17	GND	-			GND	-		
U6	GND	-			GND	-		
W2	GND	-			GND	-		
W21	GND	-			GND	-		
Y14	GND	-			GND	-		
Y9	GND	-			GND	-		
A1	GND	-			GND	-		
N18	VCCPLL	-			VCCPLL	-		
K6	NC	-			VCCPLL	-		
N6	VCCPLL	-			VCCPLL	-		
J16	NC	-			VCCPLL	-		

* Supports true LVDS. Other differential signals must be emulated with external resistors.

** These dedicated input pins can be used for GPLLs or GDLLs within the respective quadrant.

***Due to packaging bond out option, this DQS does not have all the necessary DQ pins bonded out for a full 8-bit data width.

Note: VCCIO and GND pads are used to determine the average DC current drawn by I/Os between GND/VCCIO connections, or between the last GND/VCCIO in an I/O bank and the end of an I/O bank. The substrate pads listed in the Pin Table do not necessarily have a one to one connection with a package ball or pin.

LFE2-20E/SE and LFE2-35E/SE Logic Signal Connections: 672 fpBGA

LFE2-20E/20SE					LFE2-35E/35SE			
Ball Number	Ball/Pad Function	Bank	Dual Function	Differential	Ball/Pad Function	Bank	Dual Function	Differential
D2	PL2A	7	VREF2_7	T (LVDS)*	PL2A	7	VREF2_7/LDQ6	T (LVDS)*
D1	PL2B	7	VREF1_7	C (LVDS)*	PL2B	7	VREF1_7/LDQ6	C (LVDS)*
GND	GNDIO7	-			GNDIO7	-		
F6	PL3A	7		T	PL3A	7	LDQ6	T
F5	PL3B	7		C	PL3B	7	LDQ6	C
VCCIO	VCCIO7	7			VCCIO7	7		
E4	NC	-			PL4A	7	LDQ6	T (LVDS)*
E3	NC	-			PL4B	7	LDQ6	C (LVDS)*
E2	NC	-			PL5A	7	LDQ6	T
E1	NC	-			PL5B	7	LDQ6	C
GND	GNDIO7	-			GNDIO7	-		
H6	NC	-			PL6A	7	LDQS6	T (LVDS)*
H5	NC	-			PL6B	7	LDQ6	C (LVDS)*
F2	NC	-			PL7A	7	LDQ6	T
VCCIO	VCCIO7	7			VCCIO7	7		
F1	NC	-			PL7B	7	LDQ6	C
H8	NC	-			PL8A	7	LDQ6	T (LVDS)*
J9	NC	-			PL8B	7	LDQ6	C (LVDS)*
G4	NC	-			PL9A	7	LDQ6	T
GND	GNDIO7	-			GNDIO7	-		
G3	NC	-			PL9B	7	LDQ6	C
H7	PL4A	7	LDQ8	T (LVDS)*	PL10A	7	LDQ14	T (LVDS)*
J8	PL4B	7	LDQ8	C (LVDS)*	PL10B	7	LDQ14	C (LVDS)*
G2	PL5A	7	LDQ8	T	PL11A	7	LDQ14	T
G1	PL5B	7	LDQ8	C	PL11B	7	LDQ14	C
H3	PL6A	7	LDQ8	T (LVDS)*	PL12A	7	LDQ14	T (LVDS)*
VCCIO	VCCIO7	7			VCCIO7	7		
H4	PL6B	7	LDQ8	C (LVDS)*	PL12B	7	LDQ14	C (LVDS)*
J5	PL7A	7	LDQ8	T	PL13A	7	LDQ14	T
J4	PL7B	7	LDQ8	C	PL13B	7	LDQ14	C
J3	PL8A	7	LDQS8	T (LVDS)*	PL14A	7	LDQS14	T (LVDS)*
GND	GNDIO7	-			GNDIO7	-		
K4	PL8B	7	LDQ8	C (LVDS)*	PL14B	7	LDQ14	C (LVDS)*
H1	PL9A	7	LDQ8	T	PL15A	7	LDQ14	T
H2	PL9B	7	LDQ8	C	PL15B	7	LDQ14	C
VCCIO	VCCIO7	7			VCCIO7	7		
K6	PL10A	7	LDQ8	T (LVDS)*	PL16A	7	LDQ14	T (LVDS)*
K7	PL10B	7	LDQ8	C (LVDS)*	PL16B	7	LDQ14	C (LVDS)*
J1	PL11A	7	LDQ8	T	PL17A	7	LDQ14	T
J2	PL11B	7	LDQ8	C	PL17B	7	LDQ14	C
GND	GNDIO7	-			GNDIO7	-		
VCCIO	VCCIO7	7			VCCIO7	7		
K3	NC	-			NC	-		
K2	NC	-			NC	-		
GND	GNDIO7	-			GNDIO7	-		
K1	NC	-			NC	-		
L2	NC	-			NC	-		

LFE2-20E/SE and LFE2-35E/SE Logic Signal Connections: 672 fpBGA

LFE2-20E/20SE					LFE2-35E/35SE			
Ball Number	Ball/Pad Function	Bank	Dual Function	Differential	Ball/Pad Function	Bank	Dual Function	Differential
L1	NC	-			NC	-		
VCCIO	VCCIO7	7			VCCIO7	7		
M2	NC	-			NC	-		
M1	NC	-			NC	-		
N2	NC	-			NC	-		
GND	GNDIO7	-			GNDIO7	-		
M8	VCC	-			NC	-		
VCCIO	VCCIO7	7			VCCIO7	7		
GND	GNDIO7	-			GNDIO7	-		
N1	PL12A	7	LDQ16		PL18A	7	LDQ22	
L8	PL13A	7	LDQ16	T	PL19A	7	LDQ22	T
K8	PL13B	7	LDQ16	C	PL19B	7	LDQ22	C
VCCIO	VCCIO7	7			VCCIO7	7		
L6	PL14A	7	LDQ16	T (LVDS)*	PL20A	7	LDQ22	T (LVDS)*
K5	PL14B	7	LDQ16	C (LVDS)*	PL20B	7	LDQ22	C (LVDS)*
L7	PL15A	7	LDQ16	T	PL21A	7	LDQ22	T
L5	PL15B	7	LDQ16	C	PL21B	7	LDQ22	C
GND	GNDIO7	-			GNDIO7	-		
P1	PL16A	7	LDQS16	T (LVDS)*	PL22A	7	LDQS22	T (LVDS)*
P2	PL16B	7	LDQ16	C (LVDS)*	PL22B	7	LDQ22	C (LVDS)*
M6	PL17A	7	LDQ16	T	PL23A	7	LDQ22	T
VCCIO	VCCIO7	7			VCCIO7	7		
N8	PL17B	7	LDQ16	C	PL23B	7	LDQ22	C
R1	PL18A	7	LDQ16	T (LVDS)*	PL24A	7	LDQ22	T (LVDS)*
R2	PL18B	7	LDQ16	C (LVDS)*	PL24B	7	LDQ22	C (LVDS)*
M7	PL19A	7	PCLKT7_0/LDQ16	T	PL25A	7	PCLKT7_0/LDQ22	T
GND	GNDIO7	-			GNDIO7	-		
N9	PL19B	7	PCLKC7_0/LDQ16	C	PL25B	7	PCLKC7_0/LDQ22	C
M4	PL21A	6	PCLKT6_0/LDQ25	T (LVDS)*	PL27A	6	PCLKT6_0/LDQ31	T (LVDS)*
M5	PL21B	6	PCLKC6_0/LDQ25	C (LVDS)*	PL27B	6	PCLKC6_0/LDQ31	C (LVDS)*
N7	PL22A	6	VREF2_6/LDQ25	T	PL28A	6	VREF2_6/LDQ31	T
P9	PL22B	6	VREF1_6/LDQ25	C	PL28B	6	VREF1_6/LDQ31	C
N3	PL23A	6	LDQ25	T (LVDS)*	PL29A	6	LDQ31	T (LVDS)*
VCCIO	VCCIO6	6			VCCIO6	6		
N4	PL23B	6	LDQ25	C (LVDS)*	PL29B	6	LDQ31	C (LVDS)*
N5	PL24A	6	LDQ25	T	PL30A	6	LDQ31	T
P7	PL24B	6	LDQ25	C	PL30B	6	LDQ31	C
T1	NC	-			PL31A	6	LDQS31	T (LVDS)*
GND	GNDIO6	-			GNDIO6	-		
T2	NC	-			PL31B	6	LDQ31	C (LVDS)*
P8	NC	-			PL32A	6	LDQ31	T
P6	NC	-			PL32B	6	LDQ31	C
VCCIO	VCCIO6	6			VCCIO6	6		
P5	NC	-			PL33A	6	LDQ31	T (LVDS)*
P4	NC	-			PL33B	6	LDQ31	C (LVDS)*
U1	NC	-			PL34A	6	LDQ31	T
V1	NC	-			PL34B	6	LDQ31	C

LFE2-20E/SE and LFE2-35E/SE Logic Signal Connections: 672 fpBGA

LFE2-20E/20SE					LFE2-35E/35SE			
Ball Number	Ball/Pad Function	Bank	Dual Function	Differential	Ball/Pad Function	Bank	Dual Function	Differential
GND	GNDIO6	-			GNDIO6	-		
P3	NC	-			NC	-		
R3	NC	-			NC	-		
R4	NC	-			NC	-		
U2	NC	-			NC	-		
VCCIO	VCCIO6	6			VCCIO6	6		
V2	NC	-			NC	-		
W2	NC	-			NC	-		
T6	NC	-			PL38A	6	LDQ39	T
R5	NC	-			PL38B	6	LDQ39	C
GND	GNDIO6	-			GNDIO6	-		
R6	PL25A	6	LDQS25***	T (LVDS)*	PL39A	6	LDQS39***	T (LVDS)*
R7	PL25B	6	LDQ25	C (LVDS)*	PL39B	6	LDQ39	C (LVDS)*
W1	PL26A	6	LDQ25	T	PL40A	6	LDQ39	T
VCCIO	VCCIO6	6			VCCIO6	6		
Y2	PL26B	6	LDQ25	C	PL40B	6	LDQ39	C
Y1	PL27A	6	LLM0_GDLLT_IN_A**/LDQ25	T (LVDS)*	PL41A	6	LLM0_GDLLT_IN_A**/LDQ39	T (LVDS)*
AA2	PL27B	6	LLM0_GDLLC_IN_A**/LDQ25	C (LVDS)*	PL41B	6	LLM0_GDLLC_IN_A**/LDQ39	C (LVDS)*
T5	PL28A	6	LLM0_GDLLT_FB_A/LDQ25	T	PL42A	6	LLM0_GDLLT_FB_A/LDQ39	T
GND	GNDIO6	-			GNDIO6	-		
T7	PL28B	6	LLM0_GDLLC_FB_A/LDQ25	C	PL42B	6	LLM0_GDLLC_FB_A/LDQ39	C
R8	VCC	6			VCCPLL	6		
T8	LLM0_PLLCAP	6			LLM0_PLLCAP	6		
U3	PL30A	6	LLM0_GPLLT_IN_A**/LDQ34	T (LVDS)*	PL44A	6	LLM0_GPLLT_IN_A**/LDQ48	T (LVDS)*
U4	PL30B	6	LLM0_GPLLC_IN_A**/LDQ34	C (LVDS)*	PL44B	6	LLM0_GPLLC_IN_A**/LDQ48	C (LVDS)*
V3	PL31A	6	LLM0_GPLLT_FB_A/LDQ34	T	PL45A	6	LLM0_GPLLT_FB_A/LDQ48	T
U5	PL31B	6	LLM0_GPLLC_FB_A/LDQ34	C	PL45B	6	LLM0_GPLLC_FB_A/LDQ48	C
V4	PL32A	6	LDQ34	T (LVDS)*	PL46A	6	LDQ48	T (LVDS)*
VCCIO	VCCIO6	6			VCCIO6	6		
V5	PL32B	6	LDQ34	C (LVDS)*	PL46B	6	LDQ48	C (LVDS)*
Y3	PL33A	6	LDQ34	T	PL47A	6	LDQ48	T
Y4	PL33B	6	LDQ34	C	PL47B	6	LDQ48	C
W3	PL34A	6	LDQS34	T (LVDS)*	PL48A	6	LDQS48	T (LVDS)*
GND	GNDIO6	-			GNDIO6	-		
W4	PL34B	6	LDQ34	C (LVDS)*	PL48B	6	LDQ48	C (LVDS)*
AA1	PL35A	6	LDQ34	T	PL49A	6	LDQ48	T
AB1	PL35B	6	LDQ34	C	PL49B	6	LDQ48	C
VCCIO	VCCIO6	6			VCCIO6	6		
U8	PL36A	6	LDQ34	T (LVDS)*	PL50A	6	LDQ48	T (LVDS)*
U7	PL36B	6	LDQ34	C (LVDS)*	PL50B	6	LDQ48	C (LVDS)*
V8	PL37A	6	LDQ34	T	PL51A	6	LDQ48	T
U6	PL37B	6	LDQ34	C	PL51B	6	LDQ48	C
GND	GNDIO6	-			GNDIO6	-		
W6	PL38A	6	LDQ42	T (LVDS)*	PL52A	6	LDQ56	T (LVDS)*
W5	PL38B	6	LDQ42	C (LVDS)*	PL52B	6	LDQ56	C (LVDS)*
AC1	PL39A	6	LDQ42	T	PL53A	6	LDQ56	T
AD1	PL39B	6	LDQ42	C	PL53B	6	LDQ56	C

LFE2-20E/SE and LFE2-35E/SE Logic Signal Connections: 672 fpBGA

LFE2-20E/20SE					LFE2-35E/35SE			
Ball Number	Ball/Pad Function	Bank	Dual Function	Differential	Ball/Pad Function	Bank	Dual Function	Differential
VCCIO	VCCIO6	6			VCCIO6	6		
Y6	PL40A	6	LDQ42	T (LVDS)*	PL54A	6	LDQ56	T (LVDS)*
Y5	PL40B	6	LDQ42	C (LVDS)*	PL54B	6	LDQ56	C (LVDS)*
AE2	PL41A	6	LDQ42	T	PL55A	6	LDQ56	T
AD2	PL41B	6	LDQ42	C	PL55B	6	LDQ56	C
GND	GNDIO6	-			GNDIO6	-		
AB3	PL42A	6	LDQS42	T (LVDS)*	PL56A	6	LDQS56	T (LVDS)*
AB2	PL42B	6	LDQ42	C (LVDS)*	PL56B	6	LDQ56	C (LVDS)*
W7	PL43A	6	LDQ42	T	PL57A	6	LDQ56	T
VCCIO	VCCIO6	6			VCCIO6	6		
W8	PL43B	6	LDQ42	C	PL57B	6	LDQ56	C
Y7	PL44A	6	LDQ42	T (LVDS)*	PL58A	6	LDQ56	T (LVDS)*
Y8	PL44B	6	LDQ42	C (LVDS)*	PL58B	6	LDQ56	C (LVDS)*
AC2	PL45A	6	LDQ42	T	PL59A	6	LDQ56	T
GND	GNDIO6	-			GNDIO6	-		
AD3	PL45B	6	LDQ42	C	PL59B	6	LDQ56	C
AC3	TCK	-			TCK	-		
AA8	TDI	-			TDI	-		
AB4	TMS	-			TMS	-		
AA5	TDO	-			TDO	-		
AB5	VCCJ	-			VCCJ	-		
AE3	PB2A	5	VREF2_5/BDQ6	T	PB2A	5	VREF2_5/BDQ6	T
AF3	PB2B	5	VREF1_5/BDQ6	C	PB2B	5	VREF1_5/BDQ6	C
AC4	PB3A	5	BDQ6	T	PB3A	5	BDQ6	T
AD4	PB3B	5	BDQ6	C	PB3B	5	BDQ6	C
AE4	PB4A	5	BDQ6	T	PB4A	5	BDQ6	T
AF4	PB4B	5	BDQ6	C	PB4B	5	BDQ6	C
VCCIO	VCCIO5	5			VCCIO5	5		
V9	PB5A	5	BDQ6	T	PB5A	5	BDQ6	T
W9	PB5B	5	BDQ6	C	PB5B	5	BDQ6	C
GND	GNDIO5	-			GNDIO5	-		
AA6	PB6A	5	BDQS6	T	PB6A	5	BDQS6	T
AB6	PB6B	5	BDQ6	C	PB6B	5	BDQ6	C
AC5	PB7A	5	BDQ6	T	PB7A	5	BDQ6	T
AD5	PB7B	5	BDQ6	C	PB7B	5	BDQ6	C
AA7	PB8A	5	BDQ6	T	PB8A	5	BDQ6	T
AB7	PB8B	5	BDQ6	C	PB8B	5	BDQ6	C
VCCIO	VCCIO5	5			VCCIO5	5		
AE5	PB9A	5	BDQ6	T	PB9A	5	BDQ6	T
AF5	PB9B	5	BDQ6	C	PB9B	5	BDQ6	C
AC7	PB10A	5	BDQ6	T	PB10A	5	BDQ6	T
AD7	PB10B	5	BDQ6	C	PB10B	5	BDQ6	C
VCCIO	VCCIO5	5			VCCIO5	5		
GND	GNDIO5	-			GNDIO5	-		
W10	PB11A	5	BDQ15	T	PB11A	5	BDQ15	T
Y10	PB11B	5	BDQ15	C	PB11B	5	BDQ15	C
W11	PB12A	5	BDQ15	T	PB12A	5	BDQ15	T

LFE2-20E/SE and LFE2-35E/SE Logic Signal Connections: 672 fpBGA

LFE2-20E/20SE					LFE2-35E/35SE				
Ball Number	Ball/Pad Function	Bank	Dual Function	Differential	Ball/Pad Function	Bank	Dual Function	Differential	
AA10	PB12B	5	BDQ15	C	PB12B	5	BDQ15	C	
AC8	PB13A	5	BDQ15	T	PB13A	5	BDQ15	T	
AD8	PB13B	5	BDQ15	C	PB13B	5	BDQ15	C	
VCCIO	VCCIO5	5			VCCIO5	5			
AB8	PB14A	5	BDQ15	T	PB14A	5	BDQ15	T	
AB10	PB14B	5	BDQ15	C	PB14B	5	BDQ15	C	
GND	GNDIO5	-			GNDIO5	-			
AE6	PB15A	5	BDQS15	T	PB15A	5	BDQS15	T	
AF6	PB15B	5	BDQ15	C	PB15B	5	BDQ15	C	
AA11	PB16A	5	BDQ15	T	PB16A	5	BDQ15	T	
AC9	PB16B	5	BDQ15	C	PB16B	5	BDQ15	C	
AB9	PB17A	5	BDQ15	T	PB17A	5	BDQ15	T	
AD9	PB17B	5	BDQ15	C	PB17B	5	BDQ15	C	
VCCIO	VCCIO5	5			VCCIO5	5			
Y11	PB18A	5	BDQ15	T	PB18A	5	BDQ15	T	
AB11	PB18B	5	BDQ15	C	PB18B	5	BDQ15	C	
AE7	PB19A	5	BDQ15	T	PB19A	5	BDQ15	T	
AF7	PB19B	5	BDQ15	C	PB19B	5	BDQ15	C	
GND	GNDIO5	-			GNDIO5	-			
AC10	PB20A	5	BDQ24	T	PB20A	5	BDQ24	T	
AD10	PB20B	5	BDQ24	C	PB20B	5	BDQ24	C	
AA12	PB21A	5	BDQ24	T	PB21A	5	BDQ24	T	
W12	PB21B	5	BDQ24	C	PB21B	5	BDQ24	C	
AB12	PB22A	5	BDQ24	T	PB22A	5	BDQ24	T	
VCCIO	VCCIO5	5			VCCIO5	5			
Y12	PB22B	5	BDQ24	C	PB22B	5	BDQ24	C	
AD12	PB23A	5	BDQ24	T	PB23A	5	BDQ24	T	
AC12	PB23B	5	BDQ24	C	PB23B	5	BDQ24	C	
AC13	PB24A	5	BDQS24	T	PB24A	5	BDQS24	T	
GND	GNDIO5	-			GNDIO5	-			
AA13	PB24B	5	BDQ24	C	PB24B	5	BDQ24	C	
AD13	PB25A	5	BDQ24	T	PB25A	5	BDQ24	T	
AC14	PB25B	5	BDQ24	C	PB25B	5	BDQ24	C	
AE8	PB26A	5	BDQ24	T	PB26A	5	BDQ24	T	
VCCIO	VCCIO5	5			VCCIO5	5			
AF8	PB26B	5	BDQ24	C	PB26B	5	BDQ24	C	
AB15	PB27A	5	BDQ24	T	PB27A	5	BDQ24	T	
Y13	PB27B	5	BDQ24	C	PB27B	5	BDQ24	C	
AE9	PB28A	5	BDQ24	T	PB28A	5	BDQ24	T	
GND	GNDIO5	-			GNDIO5	-			
AF9	PB28B	5	BDQ24	C	PB28B	5	BDQ24	C	
W13	PB29A	5	BDQ33	T	PB29A	5	BDQ33	T	
AA14	PB29B	5	BDQ33	C	PB29B	5	BDQ33	C	
AE10	PB30A	5	BDQ33	T	PB30A	5	BDQ33	T	
AF10	PB30B	5	BDQ33	C	PB30B	5	BDQ33	C	
W14	PB31A	5	BDQ33	T	PB31A	5	BDQ33	T	
AB13	PB31B	5	BDQ33	C	PB31B	5	BDQ33	C	

LFE2-20E/SE and LFE2-35E/SE Logic Signal Connections: 672 fpBGA

LFE2-20E/20SE					LFE2-35E/35SE				
Ball Number	Ball/Pad Function	Bank	Dual Function	Differential	Ball/Pad Function	Bank	Dual Function	Differential	
VCCIO	VCCIO5	5			VCCIO5	5			
Y14	PB32A	5	BDQ33	T	PB32A	5	BDQ33	T	
AB14	PB32B	5	BDQ33	C	PB32B	5	BDQ33	C	
GND	GNDIO5	-			GNDIO5	-			
AE11	PB33A	5	BDQS33	T	PB33A	5	BDQS33	T	
AF11	PB33B	5	BDQ33	C	PB33B	5	BDQ33	C	
AD14	PB34A	5	BDQ33	T	PB34A	5	BDQ33	T	
AA15	PB34B	5	BDQ33	C	PB34B	5	BDQ33	C	
AE12	PB35A	5	PCLKT5_0/BDQ33	T	PB35A	5	PCLKT5_0/BDQ33	T	
AF12	PB35B	5	PCLKC5_0/BDQ33	C	PB35B	5	PCLKC5_0/BDQ33	C	
VCCIO	VCCIO5	5			VCCIO5	5			
GND	GNDIO5	-			GNDIO5	-			
AD15	PB40A	4	PCLKT4_0/BDQ42	T	PB40A	4	PCLKT4_0/BDQ42	T	
VCCIO	VCCIO4	4			VCCIO4	4			
AC15	PB40B	4	PCLKC4_0/BDQ42	C	PB40B	4	PCLKC4_0/BDQ42	C	
AE13	PB41A	4	BDQ42	T	PB41A	4	BDQ42	T	
AF13	PB41B	4	BDQ42	C	PB41B	4	BDQ42	C	
AB17	PB42A	4	BDQS42	T	PB42A	4	BDQS42	T	
GND	GNDIO4	-			GNDIO4	-			
Y15	PB42B	4	BDQ42	C	PB42B	4	BDQ42	C	
AE14	PB43A	4	BDQ42	T	PB43A	4	BDQ42	T	
AF14	PB43B	4	BDQ42	C	PB43B	4	BDQ42	C	
AA16	PB44A	4	BDQ42	T	PB44A	4	BDQ42	T	
VCCIO	VCCIO4	4			VCCIO4	4			
W15	PB44B	4	BDQ42	C	PB44B	4	BDQ42	C	
AC17	PB45A	4	BDQ42	T	PB45A	4	BDQ42	T	
AB16	PB45B	4	BDQ42	C	PB45B	4	BDQ42	C	
AE15	PB46A	4	BDQ42	T	PB46A	4	BDQ42	T	
GND	GNDIO4	-			GNDIO4	-			
AF15	PB46B	4	BDQ42	C	PB46B	4	BDQ42	C	
AE16	PB47A	4	BDQ51	T	PB47A	4	BDQ51	T	
AF16	PB47B	4	BDQ51	C	PB47B	4	BDQ51	C	
Y16	PB48A	4	BDQ51	T	PB48A	4	BDQ51	T	
AB18	PB48B	4	BDQ51	C	PB48B	4	BDQ51	C	
AD17	PB49A	4	BDQ51	T	PB49A	4	BDQ51	T	
AD18	PB49B	4	BDQ51	C	PB49B	4	BDQ51	C	
VCCIO	VCCIO4	4			VCCIO4	4			
AC18	PB50A	4	BDQ51	T	PB50A	4	BDQ51	T	
AD19	PB50B	4	BDQ51	C	PB50B	4	BDQ51	C	
GND	GNDIO4	-			GNDIO4	-			
AC19	PB51A	4	BDQS51	T	PB51A	4	BDQS51	T	
AE17	PB51B	4	BDQ51	C	PB51B	4	BDQ51	C	
AB19	PB52A	4	BDQ51	T	PB52A	4	BDQ51	T	
AE19	PB52B	4	BDQ51	C	PB52B	4	BDQ51	C	
AF17	PB53A	4	BDQ51	T	PB53A	4	BDQ51	T	
AE18	PB53B	4	BDQ51	C	PB53B	4	BDQ51	C	
VCCIO	VCCIO4	4			VCCIO4	4			

LFE2-20E/SE and LFE2-35E/SE Logic Signal Connections: 672 fpBGA

LFE2-20E/20SE					LFE2-35E/35SE				
Ball Number	Ball/Pad Function	Bank	Dual Function	Differential	Ball/Pad Function	Bank	Dual Function	Differential	
W16	PB54A	4	BDQ51	T	PB54A	4	BDQ51	T	
AA17	PB54B	4	BDQ51	C	PB54B	4	BDQ51	C	
AF18	PB55A	4	BDQ51	T	PB55A	4	BDQ51	T	
AF19	PB55B	4	BDQ51	C	PB55B	4	BDQ51	C	
GND	GNDIO4	-			GNDIO4	-			
AA19	NC	-			PB56A	4	BDQ60	T	
W17	NC	-			PB56B	4	BDQ60	C	
Y19	NC	-			PB57A	4	BDQ60	T	
Y17	NC	-			PB57B	4	BDQ60	C	
AF20	NC	-			NC	-			
VCCIO	VCCIO4	4			VCCIO4	4			
AE20	NC	-			NC	-			
AA20	NC	-			NC	-			
W18	NC	-			NC	-			
AD20	NC	-			NC	-			
GND	GNDIO4	-			GNDIO4	-			
AE21	NC	-			NC	-			
AF21	NC	-			NC	-			
AF22	NC	-			NC	-			
VCCIO	VCCIO4	4			VCCIO4	4			
GND	GNDIO4	-			GNDIO4	-			
AE22	PB56A	4	BDQ60	T	PB65A	4	BDQ69	T	
AD22	PB56B	4	BDQ60	C	PB65B	4	BDQ69	C	
AF23	PB57A	4	BDQ60	T	PB66A	4	BDQ69	T	
AE23	PB57B	4	BDQ60	C	PB66B	4	BDQ69	C	
AD23	PB58A	4	BDQ60	T	PB67A	4	BDQ69	T	
AC23	PB58B	4	BDQ60	C	PB67B	4	BDQ69	C	
VCCIO	VCCIO4	4			VCCIO4	4			
AB20	PB59A	4	BDQ60	T	PB68A	4	BDQ69	T	
AC20	PB59B	4	BDQ60	C	PB68B	4	BDQ69	C	
GND	GNDIO4	-			GNDIO4	-			
AB21	PB60A	4	BDQS60	T	PB69A	4	BDQS69	T	
AC22	PB60B	4	BDQ60	C	PB69B	4	BDQ69	C	
W19	PB61A	4	BDQ60	T	PB70A	4	BDQ69	T	
AA21	PB61B	4	BDQ60	C	PB70B	4	BDQ69	C	
AF24	PB62A	4	BDQ60	T	PB71A	4	BDQ69	T	
AE24	PB62B	4	BDQ60	C	PB71B	4	BDQ69	C	
VCCIO	VCCIO4	4			VCCIO4	4			
Y20	PB63A	4	BDQ60	T	PB72A	4	BDQ69	T	
AB22	PB63B	4	BDQ60	C	PB72B	4	BDQ69	C	
Y21	PB64A	4	VREF2_4/BDQ60	T	PB73A	4	VREF2_4/BDQ69	T	
AB23	PB64B	4	VREF1_4/BDQ60	C	PB73B	4	VREF1_4/BDQ69	C	
GND	GNDIO4	-			GNDIO4	-			
AD24	CFG2	8			CFG2	8			
W20	CFG1	8			CFG1	8			
AC24	CFG0	8			CFG0	8			
V19	PROGRAMN	8			PROGRAMN	8			

LFE2-20E/SE and LFE2-35E/SE Logic Signal Connections: 672 fpBGA

LFE2-20E/20SE					LFE2-35E/35SE			
Ball Number	Ball/Pad Function	Bank	Dual Function	Differential	Ball/Pad Function	Bank	Dual Function	Differential
AA22	CCLK	8			CCLK	8		
AB24	INITN	8			INITN	8		
AD25	DONE	8			DONE	8		
GND	GNDIO8	-			GNDIO8	-		
W21	PR44B	8	WRITEN	C	PR58B	8	WRITEN	C
Y22	PR44A	8	CS1N	T	PR58A	8	CS1N	T
AC25	PR43B	8	CSN	C	PR57B	8	CSN	C
AB25	PR43A	8	D0/SPIFASTN	T	PR57A	8	D0/SPIFASTN	T
VCCIO	VCCIO8	8			VCCIO8	8		
AD26	PR42B	8	D1	C	PR56B	8	D1	C
AC26	PR42A	8	D2	T	PR56A	8	D2	T
Y23	PR41B	8	D3	C	PR55B	8	D3	C
GND	GNDIO8	-			GNDIO8	-		
W22	PR41A	8	D4	T	PR55A	8	D4	T
AA25	PR40B	8	D5	C	PR54B	8	D5	C
AB26	PR40A	8	D6	T	PR54A	8	D6	T
W23	PR39B	8	D7	C	PR53B	8	D7	C
VCCIO	VCCIO8	8			VCCIO8	8		
V22	PR39A	8	DI/CSSPI0N	T	PR53A	8	DI/CSSPI0N	T
Y24	PR38B	8	DOU/CSON	C	PR52B	8	DOU/CSON	C
Y25	PR38A	8	BUSY/SISPI	T	PR52A	8	BUSY/SISPI	T
W24	PR37B	3	RDQ34	C	PR51B	3	RDQ48	C
GND	GNDIO3	-			GNDIO3	-		
V23	PR37A	3	RDQ34	T	PR51A	3	RDQ48	T
AA26	PR36B	3	RDQ34	C (LVDS)*	PR50B	3	RDQ48	C (LVDS)*
Y26	PR36A	3	RDQ34	T (LVDS)*	PR50A	3	RDQ48	T (LVDS)*
U21	PR35B	3	RDQ34	C	PR49B	3	RDQ48	C
VCCIO	VCCIO3	3			VCCIO3	3		
U19	PR35A	3	RDQ34	T	PR49A	3	RDQ48	T
W25	PR34B	3	RDQ34	C (LVDS)*	PR48B	3	RDQ48	C (LVDS)*
W26	PR34A	3	RDQS34	T (LVDS)*	PR48A	3	RDQS48	T (LVDS)*
GND	GNDIO3	-			GNDIO3	-		
V24	PR33B	3	RDQ34	C	PR47B	3	RDQ48	C
V25	PR33A	3	RDQ34	T	PR47A	3	RDQ48	T
V26	PR32B	3	RDQ34	C (LVDS)*	PR46B	3	RDQ48	C (LVDS)*
U26	PR32A	3	RDQ34	T (LVDS)*	PR46A	3	RDQ48	T (LVDS)*
VCCIO	VCCIO3	3			VCCIO3	3		
U22	PR31B	3	RLM0_GPLL_C_FB_A/RDQ34	C	PR45B	3	RLM0_GPLL_C_FB_A/RDQ48	C
U23	PR31A	3	RLM0_GPLL_T_FB_A/RDQ34	T	PR45A	3	RLM0_GPLL_T_FB_A/RDQ48	T
U24	PR30B	3	RLM0_GPLL_C_IN_A**/RDQ34	C (LVDS)*	PR44B	3	RLM0_GPLL_C_IN_A**/RDQ48	C (LVDS)*
U25	PR30A	3	RLM0_GPLL_T_IN_A**/RDQ34	T (LVDS)*	PR44A	3	RLM0_GPLL_T_IN_A**/RDQ48	T (LVDS)*
R20	RLM0_PLLCAP	3			RLM0_PLLCAP	3		
P18	VCC	3			VCCPLL	3		
T19	PR28B	3	RLM0_GDLL_C_FB_A/RDQ25	C	PR42B	3	RLM0_GDLL_C_FB_A/RDQ39	C
U20	PR28A	3	RLM0_GDLL_T_FB_A/RDQ25	T	PR42A	3	RLM0_GDLL_T_FB_A/RDQ39	T
GND	GNDIO3	-			GNDIO3	-		
T25	PR27B	3	RLM0_GDLL_C_IN_A**/RDQ25	C (LVDS)*	PR41B	3	RLM0_GDLL_C_IN_A**/RDQ39	C (LVDS)*

LFE2-20E/SE and LFE2-35E/SE Logic Signal Connections: 672 fpBGA

LFE2-20E/20SE					LFE2-35E/35SE				
Ball Number	Ball/Pad Function	Bank	Dual Function	Differential	Ball/Pad Function	Bank	Dual Function	Differential	
T26	PR27A	3	RLM0_GDLLT_IN_A**/RDQ25	T (LVDS)*	PR41A	3	RLM0_GDLLT_IN_A**/RDQ39	T (LVDS)*	
T20	PR26B	3	RDQ25	C	PR40B	3	RDQ39	C	
T22	PR26A	3	RDQ25	T	PR40A	3	RDQ39	T	
VCCIO	VCCIO3	3			VCCIO3	3			
R26	PR25B	3	RDQ25	C (LVDS)*	PR39B	3	RDQ39	C (LVDS)*	
R25	PR25A	3	RDQS25***	T (LVDS)*	PR39A	3	RDQS39***	T (LVDS)*	
R22	NC	-			PR38B	3	RDQ39	C	
GND	GNDIO3	-			GNDIO3	-			
T21	NC	-			PR38A	3	RDQ39	T	
P26	NC	-			NC	-			
P25	NC	-			NC	-			
R24	NC	-			NC	-			
VCCIO	VCCIO3	3			VCCIO3	3			
R23	NC	-			NC	-			
P20	NC	-			NC	-			
R19	NC	-			NC	-			
P21	NC	-			PR34B	3	RDQ31	C	
GND	GNDIO3	-			GNDIO3	-			
P19	NC	-			PR34A	3	RDQ31	T	
P23	NC	-			PR33B	3	RDQ31	C (LVDS)*	
P22	NC	-			PR33A	3	RDQ31	T (LVDS)*	
N22	NC	-			PR32B	3	RDQ31	C	
VCCIO	VCCIO3	3			VCCIO3	3			
R21	NC	-			PR32A	3	RDQ31	T	
N26	NC	-			PR31B	3	RDQ31	C (LVDS)*	
N25	NC	-			PR31A	3	RDQS31	T (LVDS)*	
GND	GNDIO3	-			GNDIO3	-			
N19	PR24B	3	RDQ25	C	PR30B	3	RDQ31	C	
N20	PR24A	3	RDQ25	T	PR30A	3	RDQ31	T	
M26	PR23B	3	RDQ25	C (LVDS)*	PR29B	3	RDQ31	C (LVDS)*	
M25	PR23A	3	RDQ25	T (LVDS)*	PR29A	3	RDQ31	T (LVDS)*	
VCCIO	VCCIO3	3			VCCIO3	3			
N18	PR22B	3	VREF2_3/RDQ25	C	PR28B	3	VREF2_3/RDQ31	C	
N21	PR22A	3	VREF1_3/RDQ25	T	PR28A	3	VREF1_3/RDQ31	T	
L26	PR21B	3	PCLKC3_0/RDQ25	C (LVDS)*	PR27B	3	PCLKC3_0/RDQ31	C (LVDS)*	
L25	PR21A	3	PCLKT3_0/RDQ25	T (LVDS)*	PR27A	3	PCLKT3_0/RDQ31	T (LVDS)*	
N24	PR19B	2	PCLKC2_0/RDQ16	C	PR25B	2	PCLKC2_0/RDQ22	C	
M23	PR19A	2	PCLKT2_0/RDQ16	T	PR25A	2	PCLKT2_0/RDQ22	T	
GND	GNDIO2	-			GNDIO2	-			
L21	PR18B	2	RDQ16	C (LVDS)*	PR24B	2	RDQ22	C (LVDS)*	
K22	PR18A	2	RDQ16	T (LVDS)*	PR24A	2	RDQ22	T (LVDS)*	
M24	PR17B	2	RDQ16	C	PR23B	2	RDQ22	C	
N23	PR17A	2	RDQ16	T	PR23A	2	RDQ22	T	
VCCIO	VCCIO2	2			VCCIO2	2			
K26	PR16B	2	RDQ16	C (LVDS)*	PR22B	2	RDQ22	C (LVDS)*	
K25	PR16A	2	RDQS16	T (LVDS)*	PR22A	2	RDQS22	T (LVDS)*	
M20	PR15B	2	RDQ16	C	PR21B	2	RDQ22	C	

LFE2-20E/SE and LFE2-35E/SE Logic Signal Connections: 672 fpBGA

LFE2-20E/20SE					LFE2-35E/35SE			
Ball Number	Ball/Pad Function	Bank	Dual Function	Differential	Ball/Pad Function	Bank	Dual Function	Differential
GND	GNDIO2	-			GNDIO2	-		
M19	PR15A	2	RDQ16	T	PR21A	2	RDQ22	T
L22	PR14B	2	RDQ16	C (LVDS)*	PR20B	2	RDQ22	C (LVDS)*
M22	PR14A	2	RDQ16	T (LVDS)*	PR20A	2	RDQ22	T (LVDS)*
K21	PR13B	2	RDQ16	C	PR19B	2	RDQ22	C
VCCIO	VCCIO2	2			VCCIO2	2		
M21	PR13A	2	RDQ16	T	PR19A	2	RDQ22	T
K24	PR12B	2	RDQ16	C (LVDS)*	PR18B	2	RDQ22	C (LVDS)*
J24	PR12A	2	RDQ16	T (LVDS)*	PR18A	2	RDQ22	T (LVDS)*
GND	GNDIO2	-			GNDIO2	-		
VCCIO	VCCIO2	2			VCCIO2	2		
L20	VCC	-			NC	-		
GND	GNDIO2	-			GNDIO2	-		
J26	NC	-			NC	-		
J25	NC	-			NC	-		
J23	NC	-			NC	-		
K23	NC	-			NC	-		
VCCIO	VCCIO2	2			VCCIO2	2		
H26	NC	-			NC	-		
H25	NC	-			NC	-		
H24	NC	-			NC	-		
GND	GNDIO2	-			GNDIO2	-		
H23	NC	-			NC	-		
VCCIO	VCCIO2	2			VCCIO2	2		
G26	PR11B	2	RDQ8	C	PR17B	2	RDQ14	C
GND	GNDIO2	-			GNDIO2	-		
G25	PR11A	2	RDQ8	T	PR17A	2	RDQ14	T
F26	PR10B	2	RDQ8	C (LVDS)*	PR16B	2	RDQ14	C (LVDS)*
F25	PR10A	2	RDQ8	T (LVDS)*	PR16A	2	RDQ14	T (LVDS)*
K20	PR9B	2	RDQ8	C	PR15B	2	RDQ14	C
VCCIO	VCCIO2	2			VCCIO2	2		
L19	PR9A	2	RDQ8	T	PR15A	2	RDQ14	T
E26	PR8B	2	RDQ8	C (LVDS)*	PR14B	2	RDQ14	C (LVDS)*
E25	PR8A	2	RDQS8	T (LVDS)*	PR14A	2	RDQS14	T (LVDS)*
GND	GNDIO2	-			GNDIO2	-		
J22	PR7B	2	RDQ8	C	PR13B	2	RDQ14	C
H22	PR7A	2	RDQ8	T	PR13A	2	RDQ14	T
G24	PR6B	2	RDQ8	C (LVDS)*	PR12B	2	RDQ14	C (LVDS)*
G23	PR6A	2	RDQ8	T (LVDS)*	PR12A	2	RDQ14	T (LVDS)*
VCCIO	VCCIO2	2			VCCIO2	2		
K19	PR5B	2	RDQ8	C	PR11B	2	RDQ14	C
J19	PR5A	2	RDQ8	T	PR11A	2	RDQ14	T
D26	PR4B	2	RDQ8	C (LVDS)*	PR10B	2	RDQ14	C (LVDS)*
C26	PR4A	2	RDQ8	T (LVDS)*	PR10A	2	RDQ14	T (LVDS)*
F22	NC	-			PR9B	2	RDQ6	C
E24	NC	-			PR9A	2	RDQ6	T
GND	GNDIO2	-			GNDIO2	-		

LFE2-20E/SE and LFE2-35E/SE Logic Signal Connections: 672 fpBGA

LFE2-20E/20SE					LFE2-35E/35SE			
Ball Number	Ball/Pad Function	Bank	Dual Function	Differential	Ball/Pad Function	Bank	Dual Function	Differential
D25	NC	-			PR8B	2	RDQ6	C (LVDS)*
C25	NC	-			PR8A	2	RDQ6	T (LVDS)*
D24	NC	-			PR7B	2	RDQ6	C
B25	NC	-			PR7A	2	RDQ6	T
VCCIO	VCCIO2	2			VCCIO2	2		
H21	NC	-			PR6B	2	RDQ6	C (LVDS)*
G22	NC	-			PR6A	2	RDQS6	T (LVDS)*
B24	NC	-			PR5B	2	RDQ6	C
GND	GNDIO2	-			GNDIO2	-		
C24	NC	-			PR5A	2	RDQ6	T
D23	NC	-			PR4B	2	RDQ6	C (LVDS)*
C23	NC	-			PR4A	2	RDQ6	T (LVDS)*
G21	PR3B	2		C	PR3B	2	RDQ6	C
VCCIO	VCCIO2	2			VCCIO2	2		
H20	PR3A	2		T	PR3A	2	RDQ6	T
GND	GNDIO2	-			GNDIO2	-		
E22	PR2B	2	VREF2_2	C (LVDS)*	PR2B	2	VREF2_2/RDQ6	C (LVDS)*
F21	PR2A	2	VREF1_2	T (LVDS)*	PR2A	2	VREF1_2/RDQ6	T (LVDS)*
E23	PT64B	1	VREF2_1	C	PT73B	1	VREF2_1	C
GND	GNDIO1	-			GNDIO1	-		
D22	PT64A	1	VREF1_1	T	PT73A	1	VREF1_1	T
G20	PT63B	1		C	PT72B	1		C
J18	PT63A	1		T	PT72A	1		T
F20	PT62B	1		C	PT71B	1		C
VCCIO	VCCIO1	1			VCCIO1	1		
H19	PT62A	1		T	PT71A	1		T
A24	PT61B	1		C	PT70B	1		C
A23	PT61A	1		T	PT70A	1		T
E21	PT60B	1		C	PT69B	1		C
F19	PT60A	1		T	PT69A	1		T
C22	PT59B	1		C	PT68B	1		C
GND	GNDIO1	-			GNDIO1	-		
E20	PT59A	1		T	PT68A	1		T
B22	PT58B	1		C	PT67B	1		C
VCCIO	VCCIO1	1			VCCIO1	1		
B23	PT58A	1		T	PT67A	1		T
C20	PT57B	1		C	PT66B	1		C
D20	PT57A	1		T	PT66A	1		T
A22	PT56B	1		C	PT65B	1		C
A21	PT56A	1		T	PT65A	1		T
GND	GNDIO1	-			GNDIO1	-		
E19	NC	-			NC	-		
C19	NC	-			NC	-		
VCCIO	VCCIO1	1			VCCIO1	1		
B21	NC	-			NC	-		
B20	NC	-			NC	-		
D19	NC	-			NC	-		

LFE2-20E/SE and LFE2-35E/SE Logic Signal Connections: 672 fpBGA

LFE2-20E/20SE					LFE2-35E/35SE			
Ball Number	Ball/Pad Function	Bank	Dual Function	Differential	Ball/Pad Function	Bank	Dual Function	Differential
B19	NC	-			NC	-		
GND	GNDIO1	-			GNDIO1	-		
G17	NC	-			NC	-		
E18	NC	-			NC	-		
G19	NC	-			NC	-		
F17	NC	-			NC	-		
VCCIO	VCCIO1	1			VCCIO1	1		
A20	NC	-			NC	-		
A19	NC	-			NC	-		
E17	NC	-			NC	-		
D18	NC	-			NC	-		
B18	PT55B	1		C	PT55B	1		C
GND	GNDIO1	-			GNDIO1	-		
A18	PT55A	1		T	PT55A	1		T
E16	PT54B	1		C	PT54B	1		C
G16	PT54A	1		T	PT54A	1		T
F16	PT53B	1		C	PT53B	1		C
VCCIO	VCCIO1	1			VCCIO1	1		
H18	PT53A	1		T	PT53A	1		T
A17	PT52B	1		C	PT52B	1		C
B17	PT52A	1		T	PT52A	1		T
C18	PT51B	1		C	PT51B	1		C
B16	PT51A	1		T	PT51A	1		T
C17	PT50B	1		C	PT50B	1		C
GND	GNDIO1	-			GNDIO1	-		
D17	PT50A	1		T	PT50A	1		T
E15	PT49B	1		C	PT49B	1		C
VCCIO	VCCIO1	1			VCCIO1	1		
G15	PT49A	1		T	PT49A	1		T
A16	PT48B	1		C	PT48B	1		C
B15	PT48A	1		T	PT48A	1		T
D15	PT47B	1		C	PT47B	1		C
F15	PT47A	1		T	PT47A	1		T
A14	PT46B	1		C	PT46B	1		C
B14	PT46A	1		T	PT46A	1		T
GND	GNDIO1	-			GNDIO1	-		
C15	PT45B	1		C	PT45B	1		C
A15	PT45A	1		T	PT45A	1		T
A13	PT44B	1		C	PT44B	1		C
B13	PT44A	1		T	PT44A	1		T
VCCIO	VCCIO1	1			VCCIO1	1		
H17	PT43B	1		C	PT43B	1		C
H15	PT43A	1		T	PT43A	1		T
D13	PT42B	1		C	PT42B	1		C
C14	PT42A	1		T	PT42A	1		T
GND	GNDIO1	-			GNDIO1	-		
G14	PT41B	1		C	PT41B	1		C

LFE2-20E/SE and LFE2-35E/SE Logic Signal Connections: 672 fpBGA

LFE2-20E/20SE					LFE2-35E/35SE			
Ball Number	Ball/Pad Function	Bank	Dual Function	Differential	Ball/Pad Function	Bank	Dual Function	Differential
E14	PT41A	1		T	PT41A	1		T
A12	PT40B	1		C	PT40B	1		C
B12	PT40A	1		T	PT40A	1		T
VCCIO	VCCIO1	1			VCCIO1	1		
F14	PT39B	1	PCLKC1_0	C	PT39B	1	PCLKC1_0	C
D14	PT39A	1	PCLKT1_0	T	PT39A	1	PCLKT1_0	T
H16	XRES	1			XRES	1		
H14	PT37B	0	PCLKC0_0	C	PT37B	0	PCLKC0_0	C
GND	GNDIO0	-			GNDIO0	-		
H13	PT37A	0	PCLKT0_0	T	PT37A	0	PCLKT0_0	T
A11	PT36B	0		C	PT36B	0		C
B11	PT36A	0		T	PT36A	0		T
C13	PT35B	0		C	PT35B	0		C
VCCIO	VCCIO0	0			VCCIO0	0		
E13	PT35A	0		T	PT35A	0		T
D12	PT34B	0		C	PT34B	0		C
F13	PT34A	0		T	PT34A	0		T
A10	PT33B	0		C	PT33B	0		C
B10	PT33A	0		T	PT33A	0		T
C12	PT32B	0		C	PT32B	0		C
GND	GNDIO0	-			GNDIO0	-		
C10	PT32A	0		T	PT32A	0		T
G13	PT31B	0		C	PT31B	0		C
VCCIO	VCCIO0	0			VCCIO0	0		
H12	PT31A	0		T	PT31A	0		T
A9	PT30B	0		C	PT30B	0		C
B9	PT30A	0		T	PT30A	0		T
E12	PT29B	0		C	PT29B	0		C
G12	PT29A	0		T	PT29A	0		T
A8	PT28B	0		C	PT28B	0		C
B8	PT28A	0		T	PT28A	0		T
GND	GNDIO0	-			GNDIO0	-		
E11	PT27B	0		C	PT27B	0		C
C9	PT27A	0		T	PT27A	0		T
A7	PT26B	0		C	PT26B	0		C
B7	PT26A	0		T	PT26A	0		T
VCCIO	VCCIO0	0			VCCIO0	0		
F12	PT25B	0		C	PT25B	0		C
D10	PT25A	0		T	PT25A	0		T
H11	PT24B	0		C	PT24B	0		C
G11	PT24A	0		T	PT24A	0		T
GND	GNDIO0	-			GNDIO0	-		
A6	PT23B	0		C	PT23B	0		C
B6	PT23A	0		T	PT23A	0		T
D8	PT22B	0		C	PT22B	0		C
C8	PT22A	0		T	PT22A	0		T
VCCIO	VCCIO0	0			VCCIO0	0		

LFE2-20E/SE and LFE2-35E/SE Logic Signal Connections: 672 fpBGA

LFE2-20E/20SE					LFE2-35E/35SE			
Ball Number	Ball/Pad Function	Bank	Dual Function	Differential	Ball/Pad Function	Bank	Dual Function	Differential
F11	PT21B	0		C	PT21B	0		C
E10	PT21A	0		T	PT21A	0		T
E9	PT20B	0		C	PT20B	0		C
D9	PT20A	0		T	PT20A	0		T
G10	PT19B	0		C	PT19B	0		C
GND	GNDIO0	-			GNDIO0	-		
H10	PT19A	0		T	PT19A	0		T
A5	PT18B	0		C	PT18B	0		C
B5	PT18A	0		T	PT18A	0		T
C7	PT17B	0		C	PT17B	0		C
VCCIO	VCCIO0	0			VCCIO0	0		
D7	PT17A	0		T	PT17A	0		T
E8	PT16B	0		C	PT16B	0		C
F10	PT16A	0		T	PT16A	0		T
F8	PT15B	0		C	PT15B	0		C
H9	PT15A	0		T	PT15A	0		T
C5	PT14B	0		C	PT14B	0		C
GND	GNDIO0	-			GNDIO0	-		
D5	PT14A	0		T	PT14A	0		T
B4	PT13B	0			PT13B	0		
VCCIO	VCCIO0	0			VCCIO0	0		
GND	GNDIO0	-			GNDIO0	-		
VCCIO	VCCIO0	0			VCCIO0	0		
GND	GNDIO0	-			GNDIO0	-		
VCCIO	VCCIO0	0			VCCIO0	0		
C4	PT10B	0		C	PT10B	0		C
GND	GNDIO0	-			GNDIO0	-		
C3	PT10A	0		T	PT10A	0		T
A4	PT9B	0		C	PT9B	0		C
A3	PT9A	0		T	PT9A	0		T
B3	PT8B	0		C	PT8B	0		C
VCCIO	VCCIO0	0			VCCIO0	0		
B2	PT8A	0		T	PT8A	0		T
D4	PT7B	0		C	PT7B	0		C
D3	PT7A	0		T	PT7A	0		T
C2	PT6B	0		C	PT6B	0		C
C1	PT6A	0		T	PT6A	0		T
G8	PT5B	0		C	PT5B	0		C
GND	GNDIO0	-			GNDIO0	-		
G7	PT5A	0		T	PT5A	0		T
E7	PT4B	0		C	PT4B	0		C
VCCIO	VCCIO0	0			VCCIO0	0		
F7	PT4A	0		T	PT4A	0		T
E6	PT3B	0		C	PT3B	0		C
E5	PT3A	0		T	PT3A	0		T
G6	PT2B	0	VREF2_0	C	PT2B	0	VREF2_0	C
G5	PT2A	0	VREF1_0	T	PT2A	0	VREF1_0	T

LFE2-20E/SE and LFE2-35E/SE Logic Signal Connections: 672 fpBGA

LFE2-20E/20SE					LFE2-35E/35SE			
Ball Number	Ball/Pad Function	Bank	Dual Function	Differential	Ball/Pad Function	Bank	Dual Function	Differential
L12	VCC	-			VCC	-		
L13	VCC	-			VCC	-		
L14	VCC	-			VCC	-		
L15	VCC	-			VCC	-		
M11	VCC	-			VCC	-		
M12	VCC	-			VCC	-		
M15	VCC	-			VCC	-		
M16	VCC	-			VCC	-		
N11	VCC	-			VCC	-		
N16	VCC	-			VCC	-		
P11	VCC	-			VCC	-		
P16	VCC	-			VCC	-		
R11	VCC	-			VCC	-		
R12	VCC	-			VCC	-		
R15	VCC	-			VCC	-		
R16	VCC	-			VCC	-		
T12	VCC	-			VCC	-		
T13	VCC	-			VCC	-		
T14	VCC	-			VCC	-		
T15	VCC	-			VCC	-		
D11	VCCIO0	0			VCCIO0	0		
D6	VCCIO0	0			VCCIO0	0		
G9	VCCIO0	0			VCCIO0	0		
K12	VCCIO0	0			VCCIO0	0		
J12	VCCIO0	0			VCCIO0	0		
D16	VCCIO1	1			VCCIO1	1		
D21	VCCIO1	1			VCCIO1	1		
G18	VCCIO1	1			VCCIO1	1		
J15	VCCIO1	1			VCCIO1	1		
K15	VCCIO1	1			VCCIO1	1		
F23	VCCIO2	2			VCCIO2	2		
J20	VCCIO2	2			VCCIO2	2		
L23	VCCIO2	2			VCCIO2	2		
M17	VCCIO2	2			VCCIO2	2		
M18	VCCIO2	2			VCCIO2	2		
AA23	VCCIO3	3			VCCIO3	3		
R17	VCCIO3	3			VCCIO3	3		
R18	VCCIO3	3			VCCIO3	3		
T23	VCCIO3	3			VCCIO3	3		
V20	VCCIO3	3			VCCIO3	3		
AC16	VCCIO4	4			VCCIO4	4		
AC21	VCCIO4	4			VCCIO4	4		
U15	VCCIO4	4			VCCIO4	4		
V15	VCCIO4	4			VCCIO4	4		
Y18	VCCIO4	4			VCCIO4	4		
AC11	VCCIO5	5			VCCIO5	5		
AC6	VCCIO5	5			VCCIO5	5		

LFE2-20E/SE and LFE2-35E/SE Logic Signal Connections: 672 fpBGA

LFE2-20E/20SE					LFE2-35E/35SE			
Ball Number	Ball/Pad Function	Bank	Dual Function	Differential	Ball/Pad Function	Bank	Dual Function	Differential
U12	VCCIO5	5			VCCIO5	5		
V12	VCCIO5	5			VCCIO5	5		
Y9	VCCIO5	5			VCCIO5	5		
AA4	VCCIO6	6			VCCIO6	6		
R10	VCCIO6	6			VCCIO6	6		
R9	VCCIO6	6			VCCIO6	6		
T4	VCCIO6	6			VCCIO6	6		
V7	VCCIO6	6			VCCIO6	6		
F4	VCCIO7	7			VCCIO7	7		
J7	VCCIO7	7			VCCIO7	7		
L4	VCCIO7	7			VCCIO7	7		
M10	VCCIO7	7			VCCIO7	7		
M9	VCCIO7	7			VCCIO7	7		
AE25	VCCIO8	8			VCCIO8	8		
V18	VCCIO8	8			VCCIO8	8		
J10	VCCAUX	-			VCCAUX	-		
J11	VCCAUX	-			VCCAUX	-		
J16	VCCAUX	-			VCCAUX	-		
J17	VCCAUX	-			VCCAUX	-		
K18	VCCAUX	-			VCCAUX	-		
K9	VCCAUX	-			VCCAUX	-		
L18	VCCAUX	-			VCCAUX	-		
L9	VCCAUX	-			VCCAUX	-		
T18	VCCAUX	-			VCCAUX	-		
T9	VCCAUX	-			VCCAUX	-		
U18	VCCAUX	-			VCCAUX	-		
U9	VCCAUX	-			VCCAUX	-		
V10	VCCAUX	-			VCCAUX	-		
V11	VCCAUX	-			VCCAUX	-		
V16	VCCAUX	-			VCCAUX	-		
V17	VCCAUX	-			VCCAUX	-		
A2	GND	-			GND	-		
A25	GND	-			GND	-		
AA18	GND	-			GND	-		
AA24	GND	-			GND	-		
AA3	GND	-			GND	-		
AA9	GND	-			GND	-		
AD11	GND	-			GND	-		
AD16	GND	-			GND	-		
AD21	GND	-			GND	-		
AD6	GND	-			GND	-		
AE1	GND	-			GND	-		
AE26	GND	-			GND	-		
AF2	GND	-			GND	-		
AF25	GND	-			GND	-		
B1	GND	-			GND	-		
B26	GND	-			GND	-		

LFE2-20E/SE and LFE2-35E/SE Logic Signal Connections: 672 fpBGA

LFE2-20E/20SE					LFE2-35E/35SE			
Ball Number	Ball/Pad Function	Bank	Dual Function	Differential	Ball/Pad Function	Bank	Dual Function	Differential
C11	GND	-			GND	-		
C16	GND	-			GND	-		
C21	GND	-			GND	-		
C6	GND	-			GND	-		
F18	GND	-			GND	-		
F24	GND	-			GND	-		
F3	GND	-			GND	-		
F9	GND	-			GND	-		
J13	GND	-			GND	-		
J14	GND	-			GND	-		
J21	GND	-			GND	-		
J6	GND	-			GND	-		
K10	GND	-			GND	-		
K11	GND	-			GND	-		
K13	GND	-			GND	-		
K14	GND	-			GND	-		
K16	GND	-			GND	-		
K17	GND	-			GND	-		
L10	GND	-			GND	-		
L11	GND	-			GND	-		
L16	GND	-			GND	-		
L17	GND	-			GND	-		
L24	GND	-			GND	-		
L3	GND	-			GND	-		
M13	GND	-			GND	-		
M14	GND	-			GND	-		
N10	GND	-			GND	-		
N12	GND	-			GND	-		
N13	GND	-			GND	-		
N14	GND	-			GND	-		
N15	GND	-			GND	-		
N17	GND	-			GND	-		
P10	GND	-			GND	-		
P12	GND	-			GND	-		
P13	GND	-			GND	-		
P14	GND	-			GND	-		
P15	GND	-			GND	-		
P17	GND	-			GND	-		
R13	GND	-			GND	-		
R14	GND	-			GND	-		
T10	GND	-			GND	-		
T11	GND	-			GND	-		
T16	GND	-			GND	-		
T17	GND	-			GND	-		
T24	GND	-			GND	-		
T3	GND	-			GND	-		
U10	GND	-			GND	-		

LFE2-20E/SE and LFE2-35E/SE Logic Signal Connections: 672 fpBGA

LFE2-20E/20SE					LFE2-35E/35SE			
Ball Number	Ball/Pad Function	Bank	Dual Function	Differential	Ball/Pad Function	Bank	Dual Function	Differential
U11	GND	-			GND	-		
U13	GND	-			GND	-		
U14	GND	-			GND	-		
U16	GND	-			GND	-		
U17	GND	-			GND	-		
V13	GND	-			GND	-		
V14	GND	-			GND	-		
V21	GND	-			GND	-		
V6	GND	-			GND	-		
M3	NC	-			NC	-		
N6	NC	-			NC	-		
P24	NC	-			NC	-		

* Supports true LVDS. Other differential signals must be emulated with external resistors.

** These dedicated input pins can be used for GPLLs or GDLLs within the respective quadrant.

***Due to packaging bond out option, this DQS does not have all the necessary DQ pins bonded out for a full 8-bit data width.

Note: VCCIO and GND pads are used to determine the average DC current drawn by I/Os between GND/VCCIO connections, or between the last GND/VCCIO in an I/O bank and the end of an I/O bank. The substrate pads listed in the Pin Table do not necessarily have a one to one connection with a package ball or pin.

LFE2-50E/SE and LFE2-70E/SE Logic Signal Connections: 672 fpBGA

LFE2-50E/SE					LFE2-70E/SE			
Ball Number	Ball/Pad Function	Bank	Dual Function	Differential	Ball/Pad Function	Bank	Dual Function	Differential
D2	PL2A	7	VREF2_7	T (LVDS)*	PL2A	7	VREF2_7	T (LVDS)*
D1	PL2B	7	VREF1_7	C (LVDS)*	PL2B	7	VREF1_7	C (LVDS)*
GND	GNDIO7	-			GNDIO7	-		
F6	PL5A	7	LDQ8	T	PL18A	7	LDQ21	T
F5	PL5B	7	LDQ8	C	PL18B	7	LDQ21	C
VCCIO	VCCIO7	7			VCCIO7	7		
E4	PL6A	7	LDQ8	T (LVDS)*	PL19A	7	LDQ21	T (LVDS)*
E3	PL6B	7	LDQ8	C (LVDS)*	PL19B	7	LDQ21	C (LVDS)*
E2	PL7A	7	LDQ8	T	PL20A	7	LDQ21	T
E1	PL7B	7	LDQ8	C	PL20B	7	LDQ21	C
GND	GNDIO7	-			GNDIO7	-		
H6	PL8A	7	LDQS8	T (LVDS)*	PL21A	7	LDQS21	T (LVDS)*
H5	PL8B	7	LDQ8	C (LVDS)*	PL21B	7	LDQ21	C (LVDS)*
F2	PL9A	7	LDQ8	T	PL22A	7	LDQ21	T
VCCIO	VCCIO7	7			VCCIO7	7		
F1	PL9B	7	LDQ8	C	PL22B	7	LDQ21	C
H8	PL10A	7	LDQ8	T (LVDS)*	PL23A	7	LDQ21	T (LVDS)*
J9	PL10B	7	LDQ8	C (LVDS)*	PL23B	7	LDQ21	C (LVDS)*
G4	PL11A	7	LDQ8	T	PL24A	7	LDQ21	T
GND	GNDIO7	-			GNDIO7	-		
G3	PL11B	7	LDQ8	C	PL24B	7	LDQ21	C
H7	PL12A	7	LDQ16	T (LVDS)*	PL25A	7	LDQ29	T (LVDS)*
J8	PL12B	7	LDQ16	C (LVDS)*	PL25B	7	LDQ29	C (LVDS)*
G2	PL13A	7	LDQ16	T	PL26A	7	LDQ29	T
G1	PL13B	7	LDQ16	C	PL26B	7	LDQ29	C
H3	PL14A	7	LDQ16	T (LVDS)*	PL27A	7	LDQ29	T (LVDS)*
VCCIO	VCCIO7	7			VCCIO7	7		
H4	PL14B	7	LDQ16	C (LVDS)*	PL27B	7	LDQ29	C (LVDS)*
J5	PL15A	7	LDQ16	T	PL28A	7	LDQ29	T
J4	PL15B	7	LDQ16	C	PL28B	7	LDQ29	C
J3	PL16A	7	LDQS16	T (LVDS)*	PL29A	7	LDQS29	T (LVDS)*
GND	GNDIO7	-			GNDIO7	-		
K4	PL16B	7	LDQ16	C (LVDS)*	PL29B	7	LDQ29	C (LVDS)*
H1	PL17A	7	LDQ16	T	PL30A	7	LDQ29	T
H2	PL17B	7	LDQ16	C	PL30B	7	LDQ29	C
VCCIO	VCCIO7	7			VCCIO7	7		
K6	PL18A	7	LDQ16	T (LVDS)*	PL31A	7	LDQ29	T (LVDS)*
K7	PL18B	7	LDQ16	C (LVDS)*	PL31B	7	LDQ29	C (LVDS)*
J1	PL19A	7	LDQ16	T	PL32A	7	LDQ29	T
J2	PL19B	7	LDQ16	C	PL32B	7	LDQ29	C
GND	GNDIO7	-			GNDIO7	-		
VCCIO	VCCIO7	7			VCCIO7	7		
K3	PL23A	7	LDQ24	T	PL36A	7	LDQ37	T
K2	PL23B	7	LDQ24	C	PL36B	7	LDQ37	C
GND	GNDIO7	-			GNDIO7	-		
K1	PL24A	7	LDQS24***	T (LVDS)*	PL37A	7	LDQS37***	T (LVDS)*
L2	PL24B	7	LDQ24	C (LVDS)*	PL37B	7	LDQ37	C (LVDS)*

LFE2-50E/SE and LFE2-70E/SE Logic Signal Connections: 672 fpBGA

LFE2-50E/SE					LFE2-70E/SE				
Ball Number	Ball/Pad Function	Bank	Dual Function	Differential	Ball/Pad Function	Bank	Dual Function	Differential	
L1	PL25A	7	LUM0_SPLLT_IN_A/LDQ24	T	PL38A	7	LUM0_SPLLT_IN_A/LDQ37	T	
VCCIO	VCCIO7	7			VCCIO7	7			
M2	PL25B	7	LUM0_SPLLC_IN_A/LDQ24	C	PL38B	7	LUM0_SPLLC_IN_A/LDQ37	C	
M1	PL26A	7	LUM0_SPLLT_FB_A/LDQ24	T	PL39A	7	LUM0_SPLLT_FB_A/LDQ37	T	
N2	PL26B	7	LUM0_SPLLC_FB_A/LDQ24	C	PL39B	7	LUM0_SPLLC_FB_A/LDQ37	C	
GND	GNDIO7	-			GNDIO7	-			
M8	VCCPLL	7			NC	-			
VCCIO	VCCIO7	7			VCCIO7	7			
GND	GNDIO7	-			GNDIO7	-			
N1	PL37A	7	LDQ41		PL50A	7	LDQ54		
L8	PL38A	7	LDQ41	T	PL51A	7	LDQ54	T	
K8	PL38B	7	LDQ41	C	PL51B	7	LDQ54	C	
VCCIO	VCCIO7	7			VCCIO7	7			
L6	PL39A	7	LDQ41	T (LVDS)*	PL52A	7	LDQ54	T (LVDS)*	
K5	PL39B	7	LDQ41	C (LVDS)*	PL52B	7	LDQ54	C (LVDS)*	
L7	PL40A	7	LDQ41	T	PL53A	7	LDQ54	T	
L5	PL40B	7	LDQ41	C	PL53B	7	LDQ54	C	
GND	GNDIO7	-			GNDIO7	-			
P1	PL41A	7	LDQS41	T (LVDS)*	PL54A	7	LDQS54	T (LVDS)*	
P2	PL41B	7	LDQ41	C (LVDS)*	PL54B	7	LDQ54	C (LVDS)*	
M6	PL42A	7	LDQ41	T	PL55A	7	LDQ54	T	
VCCIO	VCCIO7	7			VCCIO7	7			
N8	PL42B	7	LDQ41	C	PL55B	7	LDQ54	C	
R1	PL43A	7	LDQ41	T (LVDS)*	PL56A	7	LDQ54	T (LVDS)*	
R2	PL43B	7	LDQ41	C (LVDS)*	PL56B	7	LDQ54	C (LVDS)*	
M7	PL44A	7	PCLKT7_0/LDQ41	T	PL57A	7	PCLKT7_0/LDQ54	T	
GND	GNDIO7	-			GNDIO7	-			
N9	PL44B	7	PCLKC7_0/LDQ41	C	PL57B	7	PCLKC7_0/LDQ54	C	
M4	PL46A	6	PCLKT6_0/LDQ50	T (LVDS)*	PL59A	6	PCLKT6_0/LDQ63	T (LVDS)*	
M5	PL46B	6	PCLKC6_0/LDQ50	C (LVDS)*	PL59B	6	PCLKC6_0/LDQ63	C (LVDS)*	
N7	PL47A	6	VREF2_6/LDQ50	T	PL60A	6	VREF2_6/LDQ63	T	
P9	PL47B	6	VREF1_6/LDQ50	C	PL60B	6	VREF1_6/LDQ63	C	
N3	PL48A	6	LDQ50	T (LVDS)*	PL61A	6	LDQ63	T (LVDS)*	
VCCIO	VCCIO6	6			VCCIO6	6			
N4	PL48B	6	LDQ50	C (LVDS)*	PL61B	6	LDQ63	C (LVDS)*	
N5	PL49A	6	LDQ50	T	PL62A	6	LDQ63	T	
P7	PL49B	6	LDQ50	C	PL62B	6	LDQ63	C	
T1	PL50A	6	LDQS50	T (LVDS)*	PL63A	6	LDQS63	T (LVDS)*	
GND	GNDIO6	-			GNDIO6	-			
T2	PL50B	6	LDQ50	C (LVDS)*	PL63B	6	LDQ63	C (LVDS)*	
P8	PL51A	6	LDQ50	T	PL64A	6	LDQ63	T	
P6	PL51B	6	LDQ50	C	PL64B	6	LDQ63	C	
VCCIO	VCCIO6	6			VCCIO6	6			
P5	PL52A	6	LDQ50	T (LVDS)*	PL65A	6	LDQ63	T (LVDS)*	
P4	PL52B	6	LDQ50	C (LVDS)*	PL65B	6	LDQ63	C (LVDS)*	
U1	PL53A	6	LDQ50	T	PL66A	6	LDQ63	T	
V1	PL53B	6	LDQ50	C	PL66B	6	LDQ63	C	

LFE2-50E/SE and LFE2-70E/SE Logic Signal Connections: 672 fpBGA

LFE2-50E/SE					LFE2-70E/SE			
Ball Number	Ball/Pad Function	Bank	Dual Function	Differential	Ball/Pad Function	Bank	Dual Function	Differential
GND	GNDIO6	-			GNDIO6	-		
P3	PL54A	6	LDQ58	T (LVDS)*	PL67A	6	LDQ71	T (LVDS)*
R3	PL54B	6	LDQ58	C (LVDS)*	PL67B	6	LDQ71	C (LVDS)*
R4	PL55A	6	LDQ58	T	PL68A	6	LDQ71	T
U2	PL55B	6	LDQ58	C	PL68B	6	LDQ71	C
VCCIO	VCCIO6	6			VCCIO6	6		
V2	PL56A	6	LDQ58	T (LVDS)*	PL69A	6	LDQ71	T (LVDS)*
W2	PL56B	6	LDQ58	C (LVDS)*	PL69B	6	LDQ71	C (LVDS)*
T6	PL57A	6	LDQ58	T	PL70A	6	LDQ71	T
R5	PL57B	6	LDQ58	C	PL70B	6	LDQ71	C
GND	GNDIO6	-			GNDIO6	-		
R6	PL58A	6	LDQS58	T (LVDS)*	PL71A	6	LDQS71	T (LVDS)*
R7	PL58B	6	LDQ58	C (LVDS)*	PL71B	6	LDQ71	C (LVDS)*
W1	PL59A	6	LDQ58	T	PL72A	6	LDQ71	T
VCCIO	VCCIO6	6			VCCIO6	6		
Y2	PL59B	6	LDQ58	C	PL72B	6	LDQ71	C
Y1	PL60A	6	LLM0_GDLLT_IN_A**/LDQ58	T (LVDS)*	PL73A	6	LLM0_GDLLT_IN_A**/LDQ71	T (LVDS)*
AA2	PL60B	6	LLM0_GDLLC_IN_A**/LDQ58	C (LVDS)*	PL73B	6	LLM0_GDLLC_IN_A**/LDQ71	C (LVDS)*
T5	PL61A	6	LLM0_GDLLT_FB_A/LDQ58	T	PL74A	6	LLM0_GDLLT_FB_A/LDQ71	T
GND	GNDIO6	-			GNDIO6	-		
T7	PL61B	6	LLM0_GDLLC_FB_D/LDQ58	C	PL74B	6	LLM0_GDLLC_FB_D/LDQ71	C
R8	VCCPLL	6			VCCPLL	-		
T8	LLM0_PLLCAP	6			LLM0_PLLCAP	6		
U3	PL63A	6	LLM0_GPLLT_IN_A**/LDQ67	T (LVDS)*	PL76A	6	LLM0_GPLLT_IN_A**/LDQ80	T (LVDS)*
U4	PL63B	6	LLM0_GPLLC_IN_A**/LDQ67	C (LVDS)*	PL76B	6	LLM0_GPLLC_IN_A**/LDQ80	C (LVDS)*
V3	PL64A	6	LLM0_GPLLT_FB_A/LDQ67	T	PL77A	6	LLM0_GPLLT_FB_A/LDQ80	T
U5	PL64B	6	LLM0_GPLLC_FB_A/LDQ67	C	PL77B	6	LLM0_GPLLC_FB_A/LDQ80	C
V4	PL65A	6	LDQ67	T (LVDS)*	PL78A	6	LDQ80	T (LVDS)*
VCCIO	VCCIO6	6			VCCIO6	6		
V5	PL65B	6	LDQ67	C (LVDS)*	PL78B	6	LDQ80	C (LVDS)*
Y3	PL66A	6	LDQ67	T	PL79A	6	LDQ80	T
Y4	PL66B	6	LDQ67	C	PL79B	6	LDQ80	C
W3	PL67A	6	LDQS67	T (LVDS)*	PL80A	6	LDQS80	T (LVDS)*
GND	GNDIO6	-			GNDIO6	-		
W4	PL67B	6	LDQ67	C (LVDS)*	PL80B	6	LDQ80	C (LVDS)*
AA1	PL68A	6	LDQ67	T	PL81A	6	LDQ80	T
AB1	PL68B	6	LDQ67	C	PL81B	6	LDQ80	C
VCCIO	VCCIO6	6			VCCIO6	6		
U8	PL69A	6	LDQ67	T (LVDS)*	PL82A	6	LDQ80	T (LVDS)*
U7	PL69B	6	LDQ67	C (LVDS)*	PL82B	6	LDQ80	C (LVDS)*
V8	PL70A	6	LDQ67	T	PL83A	6	LDQ80	T
U6	PL70B	6	LDQ67	C	PL83B	6	LDQ80	C
GND	GNDIO6	-			GNDIO6	-		
W6	PL71A	6	LDQ75	T (LVDS)*	PL84A	6	LDQ88	T (LVDS)*
W5	PL71B	6	LDQ75	C (LVDS)*	PL84B	6	LDQ88	C (LVDS)*
AC1	PL72A	6	LDQ75	T	PL85A	6	LDQ88	T
AD1	PL72B	6	LDQ75	C	PL85B	6	LDQ88	C

LFE2-50E/SE and LFE2-70E/SE Logic Signal Connections: 672 fpBGA

LFE2-50E/SE					LFE2-70E/SE			
Ball Number	Ball/Pad Function	Bank	Dual Function	Differential	Ball/Pad Function	Bank	Dual Function	Differential
VCCIO	VCCIO6	6			VCCIO6	6		
Y6	PL73A	6	LDQ75	T (LVDS)*	PL86A	6	LDQ88	T (LVDS)*
Y5	PL73B	6	LDQ75	C (LVDS)*	PL86B	6	LDQ88	C (LVDS)*
AE2	PL74A	6	LDQ75	T	PL87A	6	LDQ88	T
AD2	PL74B	6	LDQ75	C	PL87B	6	LDQ88	C
GND	GNDIO6	-			GNDIO6	-		
AB3	PL75A	6	LDQS75	T (LVDS)*	PL88A	6	LDQS88	T (LVDS)*
AB2	PL75B	6	LDQ75	C (LVDS)*	PL88B	6	LDQ88	C (LVDS)*
W7	PL76A	6	LDQ75	T	PL89A	6	LDQ88	T
VCCIO	VCCIO6	6			VCCIO6	6		
W8	PL76B	6	LDQ75	C	PL89B	6	LDQ88	C
Y7	PL77A	6	LDQ75	T (LVDS)*	PL90A	6	LDQ88	T (LVDS)*
Y8	PL77B	6	LDQ75	C (LVDS)*	PL90B	6	LDQ88	C (LVDS)*
AC2	PL78A	6	LDQ75	T	PL91A	6	LDQ88	T
GND	GNDIO6	-			GNDIO6	-		
AD3	PL78B	6	LDQ75	C	PL91B	6	LDQ88	C
AC3	TCK	-			TCK	-		
AA8	TDI	-			TDI	-		
AB4	TMS	-			TMS	-		
AA5	TDO	-			TDO	-		
AB5	VCCJ	-			VCCJ	-		
AE3	PB2A	5	VREF2_5/BDQ6	T	PB2A	5	VREF2_5/BDQ6	T
AF3	PB2B	5	VREF1_5/BDQ6	C	PB2B	5	VREF1_5/BDQ6	C
AC4	PB3A	5	BDQ6	T	PB3A	5	BDQ6	T
AD4	PB3B	5	BDQ6	C	PB3B	5	BDQ6	C
AE4	PB4A	5	BDQ6	T	PB4A	5	BDQ6	T
AF4	PB4B	5	BDQ6	C	PB4B	5	BDQ6	C
VCCIO	VCCIO5	5			VCCIO5	5		
V9	PB5A	5	BDQ6	T	PB5A	5	BDQ6	T
W9	PB5B	5	BDQ6	C	PB5B	5	BDQ6	C
GND	GNDIO5	-			GNDIO5	-		
AA6	PB6A	5	BDQS6	T	PB6A	5	BDQS6	T
AB6	PB6B	5	BDQ6	C	PB6B	5	BDQ6	C
AC5	PB7A	5	BDQ6	T	PB7A	5	BDQ6	T
AD5	PB7B	5	BDQ6	C	PB7B	5	BDQ6	C
AA7	PB8A	5	BDQ6	T	PB8A	5	BDQ6	T
AB7	PB8B	5	BDQ6	C	PB8B	5	BDQ6	C
VCCIO	VCCIO5	5			VCCIO5	5		
AE5	PB9A	5	BDQ6	T	PB9A	5	BDQ6	T
AF5	PB9B	5	BDQ6	C	PB9B	5	BDQ6	C
AC7	PB10A	5	BDQ6	T	PB10A	5	BDQ6	T
AD7	PB10B	5	BDQ6	C	PB10B	5	BDQ6	C
VCCIO	VCCIO5	5			VCCIO5	5		
GND	GNDIO5	-			GNDIO5	-		
W10	PB20A	5	BDQ24	T	PB29A	5	BDQ33	T
Y10	PB20B	5	BDQ24	C	PB29B	5	BDQ33	C
W11	PB21A	5	BDQ24	T	PB30A	5	BDQ33	T

LFE2-50E/SE and LFE2-70E/SE Logic Signal Connections: 672 fpBGA

LFE2-50E/SE					LFE2-70E/SE				
Ball Number	Ball/Pad Function	Bank	Dual Function	Differential	Ball/Pad Function	Bank	Dual Function	Differential	
AA10	PB21B	5	BDQ24	C	PB30B	5	BDQ33	C	
AC8	PB22A	5	BDQ24	T	PB31A	5	BDQ33	T	
AD8	PB22B	5	BDQ24	C	PB31B	5	BDQ33	C	
VCCIO	VCCIO5	5			VCCIO5	5			
AB8	PB23A	5	BDQ24	T	PB32A	5	BDQ33	T	
AB10	PB23B	5	BDQ24	C	PB32B	5	BDQ33	C	
GND	GNDIO5	-			GNDIO5	-			
AE6	PB24A	5	BDQS24	T	PB33A	5	BDQS33	T	
AF6	PB24B	5	BDQ24	C	PB33B	5	BDQ33	C	
AA11	PB25A	5	BDQ24	T	PB34A	5	BDQ33	T	
AC9	PB25B	5	BDQ24	C	PB34B	5	BDQ33	C	
AB9	PB26A	5	BDQ24	T	PB35A	5	BDQ33	T	
AD9	PB26B	5	BDQ24	C	PB35B	5	BDQ33	C	
VCCIO	VCCIO5	5			VCCIO5	5			
Y11	PB27A	5	BDQ24	T	PB36A	5	BDQ33	T	
AB11	PB27B	5	BDQ24	C	PB36B	5	BDQ33	C	
AE7	PB28A	5	BDQ24	T	PB37A	5	BDQ33	T	
AF7	PB28B	5	BDQ24	C	PB37B	5	BDQ33	C	
GND	GNDIO5	-			GNDIO5	-			
AC10	PB29A	5	BDQ33	T	PB38A	5	BDQ42	T	
AD10	PB29B	5	BDQ33	C	PB38B	5	BDQ42	C	
AA12	PB30A	5	BDQ33	T	PB39A	5	BDQ42	T	
W12	PB30B	5	BDQ33	C	PB39B	5	BDQ42	C	
AB12	PB31A	5	BDQ33	T	PB40A	5	BDQ42	T	
VCCIO	VCCIO5	5			VCCIO5	5			
Y12	PB31B	5	BDQ33	C	PB40B	5	BDQ42	C	
AD12	PB32A	5	BDQ33	T	PB41A	5	BDQ42	T	
AC12	PB32B	5	BDQ33	C	PB41B	5	BDQ42	C	
AC13	PB33A	5	BDQS33	T	PB42A	5	BDQS42	T	
GND	GNDIO5	-			GNDIO5	-			
AA13	PB33B	5	BDQ33	C	PB42B	5	BDQ42	C	
AD13	PB34A	5	BDQ33	T	PB43A	5	BDQ42	T	
AC14	PB34B	5	BDQ33	C	PB43B	5	BDQ42	C	
AE8	PB35A	5	BDQ33	T	PB44A	5	BDQ42	T	
VCCIO	VCCIO5	5			VCCIO5	5			
AF8	PB35B	5	BDQ33	C	PB44B	5	BDQ42	C	
AB15	PB36A	5	BDQ33	T	PB45A	5	BDQ42	T	
Y13	PB36B	5	BDQ33	C	PB45B	5	BDQ42	C	
AE9	PB37A	5	BDQ33	T	PB46A	5	BDQ42	T	
GND	GNDIO5	-			GNDIO5	-			
AF9	PB37B	5	BDQ33	C	PB46B	5	BDQ42	C	
W13	PB38A	5	BDQ42	T	PB47A	5	BDQ51	T	
AA14	PB38B	5	BDQ42	C	PB47B	5	BDQ51	C	
AE10	PB39A	5	BDQ42	T	PB48A	5	BDQ51	T	
AF10	PB39B	5	BDQ42	C	PB48B	5	BDQ51	C	
W14	PB40A	5	BDQ42	T	PB49A	5	BDQ51	T	
AB13	PB40B	5	BDQ42	C	PB49B	5	BDQ51	C	

LFE2-50E/SE and LFE2-70E/SE Logic Signal Connections: 672 fpBGA

LFE2-50E/SE					LFE2-70E/SE			
Ball Number	Ball/Pad Function	Bank	Dual Function	Differential	Ball/Pad Function	Bank	Dual Function	Differential
VCCIO	VCCIO5	5			VCCIO5	5		
Y14	PB41A	5	BDQ42	T	PB50A	5	BDQ51	T
AB14	PB41B	5	BDQ42	C	PB50B	5	BDQ51	C
GND	GNDIO5	-			GNDIO5	-		
AE11	PB42A	5	BDQS42	T	PB51A	5	BDQS51	T
AF11	PB42B	5	BDQ42	C	PB51B	5	BDQ51	C
AD14	PB43A	5	BDQ42	T	PB52A	5	BDQ51	T
AA15	PB43B	5	BDQ42	C	PB52B	5	BDQ51	C
AE12	PB44A	5	PCLKT5_0/BDQ42	T	PB53A	5	PCLKT5_0/BDQ51	T
AF12	PB44B	5	PCLKC5_0/BDQ42	C	PB53B	5	PCLKC5_0/BDQ51	C
VCCIO	VCCIO5	5			VCCIO5	5		
GND	GNDIO5	-			GNDIO5	-		
AD15	PB49A	4	PCLKT4_0/BDQ51	T	PB58A	4	PCLKT4_0/BDQ60	T
VCCIO	VCCIO4	4			VCCIO4	4		
AC15	PB49B	4	PCLKC4_0/BDQ51	C	PB58B	4	PCLKC4_0/BDQ60	C
AE13	PB50A	4	BDQ51	T	PB59A	4	BDQ60	T
AF13	PB50B	4	BDQ51	C	PB59B	4	BDQ60	C
AB17	PB51A	4	BDQS51	T	PB60A	4	BDQS60	T
GND	GNDIO4	-			GNDIO4	-		
Y15	PB51B	4	BDQ51	C	PB60B	4	BDQ60	C
AE14	PB52A	4	BDQ51	T	PB61A	4	BDQ60	T
AF14	PB52B	4	BDQ51	C	PB61B	4	BDQ60	C
AA16	PB53A	4	BDQ51	T	PB62A	4	BDQ60	T
VCCIO	VCCIO4	4			VCCIO4	4		
W15	PB53B	4	BDQ51	C	PB62B	4	BDQ60	C
AC17	PB54A	4	BDQ51	T	PB63A	4	BDQ60	T
AB16	PB54B	4	BDQ51	C	PB63B	4	BDQ60	C
AE15	PB55A	4	BDQ51	T	PB64A	4	BDQ60	T
GND	GNDIO4	-			GNDIO4	-		
AF15	PB55B	4	BDQ51	C	PB64B	4	BDQ60	C
AE16	PB56A	4	BDQ60	T	PB65A	4	BDQ69	T
AF16	PB56B	4	BDQ60	C	PB65B	4	BDQ69	C
Y16	PB57A	4	BDQ60	T	PB66A	4	BDQ69	T
AB18	PB57B	4	BDQ60	C	PB66B	4	BDQ69	C
AD17	PB58A	4	BDQ60	T	PB67A	4	BDQ69	T
AD18	PB58B	4	BDQ60	C	PB67B	4	BDQ69	C
VCCIO	VCCIO4	4			VCCIO4	4		
AC18	PB59A	4	BDQ60	T	PB68A	4	BDQ69	T
AD19	PB59B	4	BDQ60	C	PB68B	4	BDQ69	C
GND	GNDIO4	-			GNDIO4	-		
AC19	PB60A	4	BDQS60	T	PB69A	4	BDQS69	T
AE17	PB60B	4	BDQ60	C	PB69B	4	BDQ69	C
AB19	PB61A	4	BDQ60	T	PB70A	4	BDQ69	T
AE19	PB61B	4	BDQ60	C	PB70B	4	BDQ69	C
AF17	PB62A	4	BDQ60	T	PB71A	4	BDQ69	T
AE18	PB62B	4	BDQ60	C	PB71B	4	BDQ69	C
VCCIO	VCCIO4	4			VCCIO4	4		

LFE2-50E/SE and LFE2-70E/SE Logic Signal Connections: 672 fpBGA

LFE2-50E/SE					LFE2-70E/SE				
Ball Number	Ball/Pad Function	Bank	Dual Function	Differential	Ball/Pad Function	Bank	Dual Function	Differential	
W16	PB63A	4	BDQ60	T	PB72A	4	BDQ69	T	
AA17	PB63B	4	BDQ60	C	PB72B	4	BDQ69	C	
AF18	PB64A	4	BDQ60	T	PB73A	4	BDQ69	T	
AF19	PB64B	4	BDQ60	C	PB73B	4	BDQ69	C	
GND	GNDIO4	-			GNDIO4	-			
AA19	PB65A	4	BDQ69	T	PB74A	4	BDQ78	T	
W17	PB65B	4	BDQ69	C	PB74B	4	BDQ78	C	
Y19	PB66A	4	BDQ69	T	PB75A	4	BDQ78	T	
Y17	PB66B	4	BDQ69	C	PB75B	4	BDQ78	C	
AF20	PB67A	4	BDQ69	T	PB76A	4	BDQ78	T	
VCCIO	VCCIO4	4			VCCIO4	4			
AE20	PB67B	4	BDQ69	C	PB76B	4	BDQ78	C	
AA20	PB68A	4	BDQ69	T	PB77A	4	BDQ78	T	
W18	PB68B	4	BDQ69	C	PB77B	4	BDQ78	C	
AD20	PB69A	4	BDQS69	T	PB78A	4	BDQS78	T	
GND	GNDIO4	-			GNDIO4	-			
AE21	PB69B	4	BDQ69	C	PB78B	4	BDQ78	C	
AF21	PB70A	4	BDQ69	T	PB79A	4	BDQ78	T	
AF22	PB70B	4	BDQ69	C	PB79B	4	BDQ78	C	
VCCIO	VCCIO4	4			VCCIO4	4			
GND	GNDIO4	-			GNDIO4	-			
AE22	PB74A	4	BDQ78	T	PB92A	4	BDQ96	T	
AD22	PB74B	4	BDQ78	C	PB92B	4	BDQ96	C	
AF23	PB75A	4	BDQ78	T	PB93A	4	BDQ96	T	
AE23	PB75B	4	BDQ78	C	PB93B	4	BDQ96	C	
AD23	PB76A	4	BDQ78	T	PB94A	4	BDQ96	T	
AC23	PB76B	4	BDQ78	C	PB94B	4	BDQ96	C	
VCCIO	VCCIO4	4			VCCIO4	4			
AB20	PB77A	4	BDQ78	T	PB95A	4	BDQ96	T	
AC20	PB77B	4	BDQ78	C	PB95B	4	BDQ96	C	
GND	GNDIO4	-			GNDIO4	-			
AB21	PB78A	4	BDQS78	T	PB96A	4	BDQS96	T	
AC22	PB78B	4	BDQ78	C	PB96B	4	BDQ96	C	
W19	PB79A	4	BDQ78	T	PB97A	4	BDQ96	T	
AA21	PB79B	4	BDQ78	C	PB97B	4	BDQ96	C	
AF24	PB80A	4	BDQ78	T	PB98A	4	BDQ96	T	
AE24	PB80B	4	BDQ78	C	PB98B	4	BDQ96	C	
VCCIO	VCCIO4	4			VCCIO4	4			
Y20	PB81A	4	BDQ78	T	PB99A	4	BDQ96	T	
AB22	PB81B	4	BDQ78	C	PB99B	4	BDQ96	C	
Y21	PB82A	4	VREF2_4/BDQ78	T	PB100A	4	VREF2_4/BDQ96	T	
AB23	PB82B	4	VREF1_4/BDQ78	C	PB100B	4	VREF1_4/BDQ96	C	
GND	GNDIO4	-			GNDIO4	-			
AD24	CFG2	8			CFG2	8			
W20	CFG1	8			CFG1	8			
AC24	CFG0	8			CFG0	8			
V19	PROGRAMN	8			PROGRAMN	8			

LFE2-50E/SE and LFE2-70E/SE Logic Signal Connections: 672 fpBGA

LFE2-50E/SE					LFE2-70E/SE			
Ball Number	Ball/Pad Function	Bank	Dual Function	Differential	Ball/Pad Function	Bank	Dual Function	Differential
AA22	CCLK	8			CCLK	8		
AB24	INITN	8			INITN	8		
AD25	DONE	8			DONE	8		
GND	GNDIO8	-			GNDIO8	-		
W21	PR77B	8	WRITEN	C	PR90B	8	WRITEN	C
Y22	PR77A	8	CS1N	T	PR90A	8	CS1N	T
AC25	PR76B	8	CSN	C	PR89B	8	CSN	C
AB25	PR76A	8	D0/SPIFASTN	T	PR89A	8	D0/SPIFASTN	T
VCCIO	VCCIO8	8			VCCIO8	8		
AD26	PR75B	8	D1	C	PR88B	8	D1	C
AC26	PR75A	8	D2	T	PR88A	8	D2	T
Y23	PR74B	8	D3	C	PR87B	8	D3	C
GND	GNDIO8	-			GNDIO8	-		
W22	PR74A	8	D4	T	PR87A	8	D4	T
AA25	PR73B	8	D5	C	PR86B	8	D5	C
AB26	PR73A	8	D6	T	PR86A	8	D6	T
W23	PR72B	8	D7	C	PR85B	8	D7	C
VCCIO	VCCIO8	8			VCCIO8	8		
V22	PR72A	8	DI/CSSPI0N	T	PR85A	8	DI/CSSPI0N	T
Y24	PR71B	8	DOUT/CSON	C	PR84B	8	DOUT/CSON	C
Y25	PR71A	8	BUSY/SISPI	T	PR84A	8	BUSY/SISPI	T
W24	PR70B	3	RDQ67	C	PR83B	3	RDQ80	C
GND	GNDIO3	-			GNDIO3	-		
V23	PR70A	3	RDQ67	T	PR83A	3	RDQ80	T
AA26	PR69B	3	RDQ67	C (LVDS)*	PR82B	3	RDQ80	C (LVDS)*
Y26	PR69A	3	RDQ67	T (LVDS)*	PR82A	3	RDQ80	T (LVDS)*
U21	PR68B	3	RDQ67	C	PR81B	3	RDQ80	C
VCCIO	VCCIO3	3			VCCIO3	3		
U19	PR68A	3	RDQ67	T	PR81A	3	RDQ80	T
W25	PR67B	3	RDQ67	C (LVDS)*	PR80B	3	RDQ80	C (LVDS)*
W26	PR67A	3	RDQS67	T (LVDS)*	PR80A	3	RDQS80	T (LVDS)*
GND	GNDIO3	-			GNDIO3	-		
V24	PR66B	3	RDQ67	C	PR79B	3	RDQ80	C
V25	PR66A	3	RDQ67	T	PR79A	3	RDQ80	T
V26	PR65B	3	RDQ67	C (LVDS)*	PR78B	3	RDQ80	C (LVDS)*
U26	PR65A	3	RDQ67	T (LVDS)*	PR78A	3	RDQ80	T (LVDS)*
VCCIO	VCCIO3	3			VCCIO3	3		
U22	PR64B	3	RLM0_GPLL_C_FB_A/RDQ67	C	PR77B	3	RLM0_GPLL_C_FB_A/RDQ80	C
U23	PR64A	3	RLM0_GPLL_T_FB_A/RDQ67	T	PR77A	3	RLM0_GPLL_T_FB_A/RDQ80	T
U24	PR63B	3	RLM0_GPLL_C_IN_A**/RDQ67	C (LVDS)*	PR76B	3	RLM0_GPLL_C_IN_A**/RDQ80	C (LVDS)*
U25	PR63A	3	RLM0_GPLL_T_IN_A**/RDQ67	T (LVDS)*	PR76A	3	RLM0_GPLL_T_IN_A**/RDQ80	T (LVDS)*
R20	RLM0_PLLCAP	3			RLM0_PLLCAP	3		
P18	VCCPLL	3			VCCPLL	-		
T19	PR61B	3	RLM0_GDLL_C_FB_A/RDQ58	C	PR74B	3	RLM0_GDLL_C_FB_A/RDQ71	C
U20	PR61A	3	RLM0_GDLL_T_FB_A/RDQ58	T	PR74A	3	RLM0_GDLL_T_FB_A/RDQ71	T
GND	GNDIO3	-			GNDIO3	-		
T25	PR60B	3	RLM0_GDLL_C_IN_A**/RDQ58	C (LVDS)*	PR73B	3	RLM0_GDLL_C_IN_A**/RDQ71	C (LVDS)*

LFE2-50E/SE and LFE2-70E/SE Logic Signal Connections: 672 fpBGA

LFE2-50E/SE					LFE2-70E/SE				
Ball Number	Ball/Pad Function	Bank	Dual Function	Differential	Ball/Pad Function	Bank	Dual Function	Differential	
T26	PR60A	3	RLM0_GDLLT_IN_A**/RDQ58	T (LVDS)*	PR73A	3	RLM0_GDLLT_IN_A**/RDQ71	T (LVDS)*	
T20	PR59B	3	RDQ58	C	PR72B	3	RDQ71	C	
T22	PR59A	3	RDQ58	T	PR72A	3	RDQ71	T	
VCCIO	VCCIO3	3			VCCIO3	3			
R26	PR58B	3	RDQ58	C (LVDS)*	PR71B	3	RDQ71	C (LVDS)*	
R25	PR58A	3	RDQS58	T (LVDS)*	PR71A	3	RDQS71	T (LVDS)*	
R22	PR57B	3	RDQ58	C	PR70B	3	RDQ71	C	
GND	GNDIO3	-			GNDIO3	-			
T21	PR57A	3	RDQ58	T	PR70A	3	RDQ71	T	
P26	PR56B	3	RDQ58	C (LVDS)*	PR69B	3	RDQ71	C (LVDS)*	
P25	PR56A	3	RDQ58	T (LVDS)*	PR69A	3	RDQ71	T (LVDS)*	
R24	PR55B	3	RDQ58	C	PR68B	3	RDQ71	C	
VCCIO	VCCIO3	3			VCCIO3	3			
R23	PR55A	3	RDQ58	T	PR68A	3	RDQ71	T	
P20	PR54B	3	RDQ58	C (LVDS)*	PR67B	3	RDQ71	C (LVDS)*	
R19	PR54A	3	RDQ58	T (LVDS)*	PR67A	3	RDQ71	T (LVDS)*	
P21	PR53B	3	RDQ50	C	PR66B	3	RDQ63	C	
GND	GNDIO3	-			GNDIO3	-			
P19	PR53A	3	RDQ50	T	PR66A	3	RDQ63	T	
P23	PR52B	3	RDQ50	C (LVDS)*	PR65B	3	RDQ63	C (LVDS)*	
P22	PR52A	3	RDQ50	T (LVDS)*	PR65A	3	RDQ63	T (LVDS)*	
N22	PR51B	3	RDQ50	C	PR64B	3	RDQ63	C	
VCCIO	VCCIO3	3			VCCIO3	3			
R21	PR51A	3	RDQ50	T	PR64A	3	RDQ63	T	
N26	PR50B	3	RDQ50	C (LVDS)*	PR63B	3	RDQ63	C (LVDS)*	
N25	PR50A	3	RDQS50	T (LVDS)*	PR63A	3	RDQS63	T (LVDS)*	
GND	GNDIO3	-			GNDIO3	-			
N19	PR49B	3	RDQ50	C	PR62B	3	RDQ63	C	
N20	PR49A	3	RDQ50	T	PR62A	3	RDQ63	T	
M26	PR48B	3	RDQ50	C (LVDS)*	PR61B	3	RDQ63	C (LVDS)*	
M25	PR48A	3	RDQ50	T (LVDS)*	PR61A	3	RDQ63	T (LVDS)*	
VCCIO	VCCIO3	3			VCCIO3	3			
N18	PR47B	3	VREF2_3/RDQ50	C	PR60B	3	VREF2_3/RDQ63	C	
N21	PR47A	3	VREF1_3/RDQ50	T	PR60A	3	VREF1_3/RDQ63	T	
L26	PR46B	3	PCLKC3_0/RDQ50	C (LVDS)*	PR59B	3	PCLKC3_0/RDQ63	C (LVDS)*	
L25	PR46A	3	PCLKT3_0/RDQ50	T (LVDS)*	PR59A	3	PCLKT3_0/RDQ63	T (LVDS)*	
N24	PR44B	2	PCLKC2_0/RDQ41	C	PR57B	2	PCLKC2_0/RDQ54	C	
M23	PR44A	2	PCLKT2_0/RDQ41	T	PR57A	2	PCLKT2_0/RDQ54	T	
GND	GNDIO2	-			GNDIO2	-			
L21	PR43B	2	RDQ41	C (LVDS)*	PR56B	2	RDQ54	C (LVDS)*	
K22	PR43A	2	RDQ41	T (LVDS)*	PR56A	2	RDQ54	T (LVDS)*	
M24	PR42B	2	RDQ41	C	PR55B	2	RDQ54	C	
N23	PR42A	2	RDQ41	T	PR55A	2	RDQ54	T	
VCCIO	VCCIO2	2			VCCIO2	2			
K26	PR41B	2	RDQ41	C (LVDS)*	PR54B	2	RDQ54	C (LVDS)*	
K25	PR41A	2	RDQS41	T (LVDS)*	PR54A	2	RDQS54	T (LVDS)*	
M20	PR40B	2	RDQ41	C	PR53B	2	RDQ54	C	

LFE2-50E/SE and LFE2-70E/SE Logic Signal Connections: 672 fpBGA

LFE2-50E/SE					LFE2-70E/SE			
Ball Number	Ball/Pad Function	Bank	Dual Function	Differential	Ball/Pad Function	Bank	Dual Function	Differential
GND	GNDIO2	-			GNDIO2	-		
M19	PR40A	2	RDQ41	T	PR53A	2	RDQ54	T
L22	PR39B	2	RDQ41	C (LVDS)*	PR52B	2	RDQ54	C (LVDS)*
M22	PR39A	2	RDQ41	T (LVDS)*	PR52A	2	RDQ54	T (LVDS)*
K21	PR38B	2	RDQ41	C	PR51B	2	RDQ54	C
VCCIO	VCCIO2	2			VCCIO2	2		
M21	PR38A	2	RDQ41	T	PR51A	2	RDQ54	T
K24	PR37B	2	RDQ41	C (LVDS)*	PR50B	2	RDQ54	C (LVDS)*
J24	PR37A	2	RDQ41	T (LVDS)*	PR50A	2	RDQ54	T (LVDS)*
GND	GNDIO2	-			GNDIO2	-		
VCCIO	VCCIO2	2			VCCIO2	2		
L20	VCCPLL	2			NC	-		
GND	GNDIO2	-			GNDIO2	-		
J26	PR26B	2	RUM0_SPLLC_FB_A/RDQ24	C	PR39B	2	RUM0_SPLLC_FB_A/RDQ37	C
J25	PR26A	2	RUM0_SPLLT_FB_A/RDQ24	T	PR39A	2	RUM0_SPLLT_FB_A/RDQ37	T
J23	PR25B	2	RUM0_SPLLC_IN_A/RDQ24	C	PR38B	2	RUM0_SPLLC_IN_A/RDQ37	C
K23	PR25A	2	RUM0_SPLLT_IN_A/RDQ24	T	PR38A	2	RUM0_SPLLT_IN_A/RDQ37	T
VCCIO	VCCIO2	2			VCCIO2	2		
H26	PR24B	2	RDQ24	C (LVDS)*	PR37B	2	RDQ37	C (LVDS)*
H25	PR24A	2	RDQS24***	T (LVDS)*	PR37A	2	RDQS37***	T (LVDS)*
H24	PR23B	2	RDQ24	C	PR36B	2	RDQ37	C
GND	GNDIO2	-			GNDIO2	-		
H23	PR23A	2	RDQ24	T	PR36A	2	RDQ37	T
VCCIO	VCCIO2	2			VCCIO2	2		
G26	PR19B	2	RDQ16	C	PR32B	2	RDQ29	C
GND	GNDIO2	-			GNDIO2	-		
G25	PR19A	2	RDQ16	T	PR32A	2	RDQ29	T
F26	PR18B	2	RDQ16	C (LVDS)*	PR31B	2	RDQ29	C (LVDS)*
F25	PR18A	2	RDQ16	T (LVDS)*	PR31A	2	RDQ29	T (LVDS)*
K20	PR17B	2	RDQ16	C	PR30B	2	RDQ29	C
VCCIO	VCCIO2	2			VCCIO2	2		
L19	PR17A	2	RDQ16	T	PR30A	2	RDQ29	T
E26	PR16B	2	RDQ16	C (LVDS)*	PR29B	2	RDQ29	C (LVDS)*
E25	PR16A	2	RDQS16	T (LVDS)*	PR29A	2	RDQS29	T (LVDS)*
GND	GNDIO2	-			GNDIO2	-		
J22	PR15B	2	RDQ16	C	PR28B	2	RDQ29	C
H22	PR15A	2	RDQ16	T	PR28A	2	RDQ29	T
G24	PR14B	2	RDQ16	C (LVDS)*	PR27B	2	RDQ29	C (LVDS)*
G23	PR14A	2	RDQ16	T (LVDS)*	PR27A	2	RDQ29	T (LVDS)*
VCCIO	VCCIO2	2			VCCIO2	2		
K19	PR13B	2	RDQ16	C	PR26B	2	RDQ29	C
J19	PR13A	2	RDQ16	T	PR26A	2	RDQ29	T
D26	PR12B	2	RDQ16	C (LVDS)*	PR25B	2	RDQ29	C (LVDS)*
C26	PR12A	2	RDQ16	T (LVDS)*	PR25A	2	RDQ29	T (LVDS)*
F22	PR11B	2	RDQ8	C	PR24B	2	RDQ21	C
E24	PR11A	2	RDQ8	T	PR24A	2	RDQ21	T
GND	GNDIO2	-			GNDIO2	-		

LFE2-50E/SE and LFE2-70E/SE Logic Signal Connections: 672 fpBGA

LFE2-50E/SE					LFE2-70E/SE			
Ball Number	Ball/Pad Function	Bank	Dual Function	Differential	Ball/Pad Function	Bank	Dual Function	Differential
D25	PR10B	2	RDQ8	C (LVDS)*	PR23B	2	RDQ21	C (LVDS)*
C25	PR10A	2	RDQ8	T (LVDS)*	PR23A	2	RDQ21	T (LVDS)*
D24	PR9B	2	RDQ8	C	PR22B	2	RDQ21	C
B25	PR9A	2	RDQ8	T	PR22A	2	RDQ21	T
VCCIO	VCCIO2	2			VCCIO2	2		
H21	PR8B	2	RDQ8	C (LVDS)*	PR21B	2	RDQ21	C (LVDS)*
G22	PR8A	2	RDQS8	T (LVDS)*	PR21A	2	RDQS21	T (LVDS)*
B24	PR7B	2	RDQ8	C	PR20B	2	RDQ21	C
GND	GNDIO2	-			GNDIO2	-		
C24	PR7A	2	RDQ8	T	PR20A	2	RDQ21	T
D23	PR6B	2	RDQ8	C (LVDS)*	PR19B	2	RDQ21	C (LVDS)*
C23	PR6A	2	RDQ8	T (LVDS)*	PR19A	2	RDQ21	T (LVDS)*
G21	PR5B	2	RDQ8	C	PR18B	2	RDQ21	C
VCCIO	VCCIO2	2			VCCIO2	2		
H20	PR5A	2	RDQ8	T	PR18A	2	RDQ21	T
GND	GNDIO2	-			GNDIO2	-		
E22	PR2B	2	VREF2_2	C (LVDS)*	PR2B	2	VREF2_2	C (LVDS)*
F21	PR2A	2	VREF1_2	T (LVDS)*	PR2A	2	VREF1_2	T (LVDS)*
E23	PT82B	1	VREF2_1	C	PT100B	1	VREF2_1	C
GND	GNDIO1	-			GNDIO1	-		
D22	PT82A	1	VREF1_1	T	PT100A	1	VREF1_1	T
G20	PT81B	1		C	PT99B	1		C
J18	PT81A	1		T	PT99A	1		T
F20	PT80B	1		C	PT98B	1		C
VCCIO	VCCIO1	1			VCCIO1	1		
H19	PT80A	1		T	PT98A	1		T
A24	PT79B	1		C	PT97B	1		C
A23	PT79A	1		T	PT97A	1		T
E21	PT78B	1		C	PT96B	1		C
F19	PT78A	1		T	PT96A	1		T
C22	PT77B	1		C	PT95B	1		C
GND	GNDIO1	-			GNDIO1	-		
E20	PT77A	1		T	PT95A	1		T
B22	PT76B	1		C	PT94B	1		C
VCCIO	VCCIO1	1			VCCIO1	1		
B23	PT76A	1		T	PT94A	1		T
C20	PT75B	1		C	PT93B	1		C
D20	PT75A	1		T	PT93A	1		T
A22	PT74B	1		C	PT92B	1		C
A21	PT74A	1		T	PT92A	1		T
GND	GNDIO1	-			GNDIO1	-		
E19	PT71B	1		C	PT85B	1		C
C19	PT71A	1		T	PT85A	1		T
VCCIO	VCCIO1	1			VCCIO1	1		
B21	PT70B	1		C	PT79B	1		C
B20	PT70A	1		T	PT79A	1		T
D19	PT69B	1		C	PT78B	1		C

LFE2-50E/SE and LFE2-70E/SE Logic Signal Connections: 672 fpBGA

LFE2-50E/SE					LFE2-70E/SE			
Ball Number	Ball/Pad Function	Bank	Dual Function	Differential	Ball/Pad Function	Bank	Dual Function	Differential
B19	PT69A	1		T	PT78A	1		T
GND	GNDIO1	-			GNDIO1	-		
G17	PT68B	1		C	PT77B	1		C
E18	PT68A	1		T	PT77A	1		T
G19	PT67B	1		C	PT76B	1		C
F17	PT67A	1		T	PT76A	1		T
VCCIO	VCCIO1	1			VCCIO1	1		
A20	PT66B	1		C	PT75B	1		C
A19	PT66A	1		T	PT75A	1		T
E17	PT65B	1		C	PT74B	1		C
D18	PT65A	1		T	PT74A	1		T
B18	PT64B	1		C	PT73B	1		C
GND	GNDIO1	-			GNDIO1	-		
A18	PT64A	1		T	PT73A	1		T
E16	PT63B	1		C	PT72B	1		C
G16	PT63A	1		T	PT72A	1		T
F16	PT62B	1		C	PT71B	1		C
VCCIO	VCCIO1	1			VCCIO1	1		
H18	PT62A	1		T	PT71A	1		T
A17	PT61B	1		C	PT70B	1		C
B17	PT61A	1		T	PT70A	1		T
C18	PT60B	1		C	PT69B	1		C
B16	PT60A	1		T	PT69A	1		T
C17	PT59B	1		C	PT68B	1		C
GND	GNDIO1	-			GNDIO1	-		
D17	PT59A	1		T	PT68A	1		T
E15	PT58B	1		C	PT67B	1		C
VCCIO	VCCIO1	1			VCCIO1	1		
G15	PT58A	1		T	PT67A	1		T
A16	PT57B	1		C	PT66B	1		C
B15	PT57A	1		T	PT66A	1		T
D15	PT56B	1		C	PT65B	1		C
F15	PT56A	1		T	PT65A	1		T
A14	PT55B	1		C	PT64B	1		C
B14	PT55A	1		T	PT64A	1		T
GND	GNDIO1	-			GNDIO1	-		
C15	PT54B	1		C	PT63B	1		C
A15	PT54A	1		T	PT63A	1		T
A13	PT53B	1		C	PT62B	1		C
B13	PT53A	1		T	PT62A	1		T
VCCIO	VCCIO1	1			VCCIO1	1		
H17	PT52B	1		C	PT61B	1		C
H15	PT52A	1		T	PT61A	1		T
D13	PT51B	1		C	PT60B	1		C
C14	PT51A	1		T	PT60A	1		T
GND	GNDIO1	-			GNDIO1	-		
G14	PT50B	1		C	PT59B	1		C

LFE2-50E/SE and LFE2-70E/SE Logic Signal Connections: 672 fpBGA

LFE2-50E/SE					LFE2-70E/SE			
Ball Number	Ball/Pad Function	Bank	Dual Function	Differential	Ball/Pad Function	Bank	Dual Function	Differential
E14	PT50A	1		T	PT59A	1		T
A12	PT49B	1		C	PT58B	1		C
B12	PT49A	1		T	PT58A	1		T
VCCIO	VCCIO1	1			VCCIO1	1		
F14	PT48B	1	PCLKC1_0	C	PT57B	1	PCLKC1_0	C
D14	PT48A	1	PCLKT1_0	T	PT57A	1	PCLKT1_0	T
H16	XRES	1			XRES	1		
H14	PT46B	0	PCLKC0_0	C	PT55B	0	PCLKC0_0	C
GND	GNDIO0	-			GNDIO0	-		
H13	PT46A	0	PCLKT0_0	T	PT55A	0	PCLKT0_0	T
A11	PT45B	0		C	PT54B	0		C
B11	PT45A	0		T	PT54A	0		T
C13	PT44B	0		C	PT53B	0		C
VCCIO	VCCIO0	0			VCCIO0	0		
E13	PT44A	0		T	PT53A	0		T
D12	PT43B	0		C	PT52B	0		C
F13	PT43A	0		T	PT52A	0		T
A10	PT42B	0		C	PT51B	0		C
B10	PT42A	0		T	PT51A	0		T
C12	PT41B	0		C	PT50B	0		C
GND	GNDIO0	-			GNDIO0	-		
C10	PT41A	0		T	PT50A	0		T
G13	PT40B	0		C	PT49B	0		C
VCCIO	VCCIO0	0			VCCIO0	0		
H12	PT40A	0		T	PT49A	0		T
A9	PT39B	0		C	PT48B	0		C
B9	PT39A	0		T	PT48A	0		T
E12	PT38B	0		C	PT47B	0		C
G12	PT38A	0		T	PT47A	0		T
A8	PT37B	0		C	PT46B	0		C
B8	PT37A	0		T	PT46A	0		T
GND	GNDIO0	-			GNDIO0	-		
E11	PT36B	0		C	PT45B	0		C
C9	PT36A	0		T	PT45A	0		T
A7	PT35B	0		C	PT44B	0		C
B7	PT35A	0		T	PT44A	0		T
VCCIO	VCCIO0	0			VCCIO0	0		
F12	PT34B	0		C	PT43B	0		C
D10	PT34A	0		T	PT43A	0		T
H11	PT33B	0		C	PT42B	0		C
G11	PT33A	0		T	PT42A	0		T
GND	GNDIO0	-			GNDIO0	-		
A6	PT32B	0		C	PT41B	0		C
B6	PT32A	0		T	PT41A	0		T
D8	PT31B	0		C	PT40B	0		C
C8	PT31A	0		T	PT40A	0		T
VCCIO	VCCIO0	0			VCCIO0	0		

LFE2-50E/SE and LFE2-70E/SE Logic Signal Connections: 672 fpBGA

LFE2-50E/SE					LFE2-70E/SE			
Ball Number	Ball/Pad Function	Bank	Dual Function	Differential	Ball/Pad Function	Bank	Dual Function	Differential
F11	PT30B	0		C	PT39B	0		C
E10	PT30A	0		T	PT39A	0		T
E9	PT29B	0		C	PT38B	0		C
D9	PT29A	0		T	PT38A	0		T
G10	PT28B	0		C	PT37B	0		C
GND	GNDIO0	-			GNDIO0	-		
H10	PT28A	0		T	PT37A	0		T
A5	PT27B	0		C	PT36B	0		C
B5	PT27A	0		T	PT36A	0		T
C7	PT26B	0		C	PT35B	0		C
VCCIO	VCCIO0	0			VCCIO0	0		
D7	PT26A	0		T	PT35A	0		T
E8	PT25B	0		C	PT34B	0		C
F10	PT25A	0		T	PT34A	0		T
F8	PT24B	0		C	PT33B	0		C
H9	PT24A	0		T	PT33A	0		T
C5	PT23B	0		C	PT32B	0		C
GND	GNDIO0	-			GNDIO0	-		
D5	PT23A	0		T	PT32A	0		T
B4	PT22B	0			PT31B	0		
VCCIO	VCCIO0	0			VCCIO0	0		
GND	GNDIO0	-			GNDIO0	-		
VCCIO	VCCIO0	0			VCCIO0	0		
GND	GNDIO0	-			GNDIO0	-		
VCCIO	VCCIO0	0			VCCIO0	0		
C4	PT10B	0		C	PT10B	0		C
GND	GNDIO0	-			GNDIO0	-		
C3	PT10A	0		T	PT10A	0		T
A4	PT9B	0		C	PT9B	0		C
A3	PT9A	0		T	PT9A	0		T
B3	PT8B	0		C	PT8B	0		C
VCCIO	VCCIO0	0			VCCIO0	0		
B2	PT8A	0		T	PT8A	0		T
D4	PT7B	0		C	PT7B	0		C
D3	PT7A	0		T	PT7A	0		T
C2	PT6B	0		C	PT6B	0		C
C1	PT6A	0		T	PT6A	0		T
G8	PT5B	0		C	PT5B	0		C
GND	GNDIO0	-			GNDIO0	-		
G7	PT5A	0		T	PT5A	0		T
E7	PT4B	0		C	PT4B	0		C
VCCIO	VCCIO0	0			VCCIO0	0		
F7	PT4A	0		T	PT4A	0		T
E6	PT3B	0		C	PT3B	0		C
E5	PT3A	0		T	PT3A	0		T
G6	PT2B	0	VREF2_0	C	PT2B	0	VREF2_0	C
G5	PT2A	0	VREF1_0	T	PT2A	0	VREF1_0	T

LFE2-50E/SE and LFE2-70E/SE Logic Signal Connections: 672 fpBGA

LFE2-50E/SE					LFE2-70E/SE			
Ball Number	Ball/Pad Function	Bank	Dual Function	Differential	Ball/Pad Function	Bank	Dual Function	Differential
L12	VCC	-			VCC	-		
L13	VCC	-			VCC	-		
L14	VCC	-			VCC	-		
L15	VCC	-			VCC	-		
M11	VCC	-			VCC	-		
M12	VCC	-			VCC	-		
M15	VCC	-			VCC	-		
M16	VCC	-			VCC	-		
N11	VCC	-			VCC	-		
N16	VCC	-			VCC	-		
P11	VCC	-			VCC	-		
P16	VCC	-			VCC	-		
R11	VCC	-			VCC	-		
R12	VCC	-			VCC	-		
R15	VCC	-			VCC	-		
R16	VCC	-			VCC	-		
T12	VCC	-			VCC	-		
T13	VCC	-			VCC	-		
T14	VCC	-			VCC	-		
T15	VCC	-			VCC	-		
D11	VCCIO0	0			VCCIO0	0		
D6	VCCIO0	0			VCCIO0	0		
G9	VCCIO0	0			VCCIO0	0		
K12	VCCIO0	0			VCCIO0	0		
J12	VCCIO0	0			VCCIO0	0		
D16	VCCIO1	1			VCCIO1	1		
D21	VCCIO1	1			VCCIO1	1		
G18	VCCIO1	1			VCCIO1	1		
J15	VCCIO1	1			VCCIO1	1		
K15	VCCIO1	1			VCCIO1	1		
F23	VCCIO2	2			VCCIO2	2		
J20	VCCIO2	2			VCCIO2	2		
L23	VCCIO2	2			VCCIO2	2		
M17	VCCIO2	2			VCCIO2	2		
M18	VCCIO2	2			VCCIO2	2		
AA23	VCCIO3	3			VCCIO3	3		
R17	VCCIO3	3			VCCIO3	3		
R18	VCCIO3	3			VCCIO3	3		
T23	VCCIO3	3			VCCIO3	3		
V20	VCCIO3	3			VCCIO3	3		
AC16	VCCIO4	4			VCCIO4	4		
AC21	VCCIO4	4			VCCIO4	4		
U15	VCCIO4	4			VCCIO4	4		
V15	VCCIO4	4			VCCIO4	4		
Y18	VCCIO4	4			VCCIO4	4		
AC11	VCCIO5	5			VCCIO5	5		
AC6	VCCIO5	5			VCCIO5	5		

LFE2-50E/SE and LFE2-70E/SE Logic Signal Connections: 672 fpBGA

LFE2-50E/SE					LFE2-70E/SE			
Ball Number	Ball/Pad Function	Bank	Dual Function	Differential	Ball/Pad Function	Bank	Dual Function	Differential
U12	VCCIO5	5			VCCIO5	5		
V12	VCCIO5	5			VCCIO5	5		
Y9	VCCIO5	5			VCCIO5	5		
AA4	VCCIO6	6			VCCIO6	6		
R10	VCCIO6	6			VCCIO6	6		
R9	VCCIO6	6			VCCIO6	6		
T4	VCCIO6	6			VCCIO6	6		
V7	VCCIO6	6			VCCIO6	6		
F4	VCCIO7	7			VCCIO7	7		
J7	VCCIO7	7			VCCIO7	7		
L4	VCCIO7	7			VCCIO7	7		
M10	VCCIO7	7			VCCIO7	7		
M9	VCCIO7	7			VCCIO7	7		
AE25	VCCIO8	8			VCCIO8	8		
V18	VCCIO8	8			VCCIO8	8		
J10	VCCAUX	-			VCCAUX	-		
J11	VCCAUX	-			VCCAUX	-		
J16	VCCAUX	-			VCCAUX	-		
J17	VCCAUX	-			VCCAUX	-		
K18	VCCAUX	-			VCCAUX	-		
K9	VCCAUX	-			VCCAUX	-		
L18	VCCAUX	-			VCCAUX	-		
L9	VCCAUX	-			VCCAUX	-		
T18	VCCAUX	-			VCCAUX	-		
T9	VCCAUX	-			VCCAUX	-		
U18	VCCAUX	-			VCCAUX	-		
U9	VCCAUX	-			VCCAUX	-		
V10	VCCAUX	-			VCCAUX	-		
V11	VCCAUX	-			VCCAUX	-		
V16	VCCAUX	-			VCCAUX	-		
V17	VCCAUX	-			VCCAUX	-		
A2	GND	-			GND	-		
A25	GND	-			GND	-		
AA18	GND	-			GND	-		
AA24	GND	-			GND	-		
AA3	GND	-			GND	-		
AA9	GND	-			GND	-		
AD11	GND	-			GND	-		
AD16	GND	-			GND	-		
AD21	GND	-			GND	-		
AD6	GND	-			GND	-		
AE1	GND	-			GND	-		
AE26	GND	-			GND	-		
AF2	GND	-			GND	-		
AF25	GND	-			GND	-		
B1	GND	-			GND	-		
B26	GND	-			GND	-		

LFE2-50E/SE and LFE2-70E/SE Logic Signal Connections: 672 fpBGA

LFE2-50E/SE					LFE2-70E/SE			
Ball Number	Ball/Pad Function	Bank	Dual Function	Differential	Ball/Pad Function	Bank	Dual Function	Differential
C11	GND	-			GND	-		
C16	GND	-			GND	-		
C21	GND	-			GND	-		
C6	GND	-			GND	-		
F18	GND	-			GND	-		
F24	GND	-			GND	-		
F3	GND	-			GND	-		
F9	GND	-			GND	-		
J13	GND	-			GND	-		
J14	GND	-			GND	-		
J21	GND	-			GND	-		
J6	GND	-			GND	-		
K10	GND	-			GND	-		
K11	GND	-			GND	-		
K13	GND	-			GND	-		
K14	GND	-			GND	-		
K16	GND	-			GND	-		
K17	GND	-			GND	-		
L10	GND	-			GND	-		
L11	GND	-			GND	-		
L16	GND	-			GND	-		
L17	GND	-			GND	-		
L24	GND	-			GND	-		
L3	GND	-			GND	-		
M13	GND	-			GND	-		
M14	GND	-			GND	-		
N10	GND	-			GND	-		
N12	GND	-			GND	-		
N13	GND	-			GND	-		
N14	GND	-			GND	-		
N15	GND	-			GND	-		
N17	GND	-			GND	-		
P10	GND	-			GND	-		
P12	GND	-			GND	-		
P13	GND	-			GND	-		
P14	GND	-			GND	-		
P15	GND	-			GND	-		
P17	GND	-			GND	-		
R13	GND	-			GND	-		
R14	GND	-			GND	-		
T10	GND	-			GND	-		
T11	GND	-			GND	-		
T16	GND	-			GND	-		
T17	GND	-			GND	-		
T24	GND	-			GND	-		
T3	GND	-			GND	-		
U10	GND	-			GND	-		

LFE2-50E/SE and LFE2-70E/SE Logic Signal Connections: 672 fpBGA

LFE2-50E/SE					LFE2-70E/SE			
Ball Number	Ball/Pad Function	Bank	Dual Function	Differential	Ball/Pad Function	Bank	Dual Function	Differential
U11	GND	-			GND	-		
U13	GND	-			GND	-		
U14	GND	-			GND	-		
U16	GND	-			GND	-		
U17	GND	-			GND	-		
V13	GND	-			GND	-		
V14	GND	-			GND	-		
V21	GND	-			GND	-		
V6	GND	-			GND	-		
M3	NC	-			NC	-		
N6	NC	-			NC	-		
P24	NC	-			NC	-		

* Supports true LVDS. Other differential signals must be emulated with external resistors.

** These dedicated input pins can be used for GPLLs or GDLLs within the respective quadrant.

***Due to packaging bond out option, this DQS does not have all the necessary DQ pins bonded out for a full 8-bit data width.

Note: VCCIO and GND pads are used to determine the average DC current drawn by I/Os between GND/VCCIO connections, or between the last GND/VCCIO in an I/O bank and the end of an I/O bank. The substrate pads listed in the Pin Table do not necessarily have a one to one connection with a package ball or pin.

LFE2-70E/SE Logic Signal Connections: 900 fpBGA

LFE2-70E/SE				
Ball Number	Ball/Pad Function	Bank	Dual Function	Differential
VCCIO	VCCIO7	7		
F4	PL2A	7	VREF2_7	T (LVDS)*
F3	PL2B	7	VREF1_7	C (LVDS)*
H4	PL3A	7		T
G5	PL3B	7		C
GND	GNDIO7	-		
D2	PL4A	7		T (LVDS)*
D1	PL4B	7		C (LVDS)*
E2	PL5A	7		T
VCCIO	VCCIO7	7		
E1	PL5B	7		C
GND	GNDIO7	-		
VCCIO	VCCIO7	7		
F1	PL14A	7	LUM1_SPLLT_IN_A/LDQ12	T (LVDS)*
F2	PL14B	7	LUM1_SPLLC_IN_A/LDQ12	C (LVDS)*
G1	PL15A	7	LUM1_SPLLT_FB_A/LDQ12	T
G2	PL15B	7	LUM1_SPLLC_FB_A/LDQ12	C
GND	GNDIO7	-		
H8	PL18A	7	LDQ21	T
H6	PL18B	7	LDQ21	C
VCCIO	VCCIO7	7		
G4	PL19A	7	LDQ21	T (LVDS)*
G3	PL19B	7	LDQ21	C (LVDS)*
H7	PL20A	7	LDQ21	T
H5	PL20B	7	LDQ21	C
GND	GNDIO7	-		
H2	PL21A	7	LDQS21	T (LVDS)*
H1	PL21B	7	LDQ21	C (LVDS)*
J6	PL22A	7	LDQ21	T
VCCIO	VCCIO7	7		
J8	PL22B	7	LDQ21	C
J2	PL23A	7	LDQ21	T (LVDS)*
J1	PL23B	7	LDQ21	C (LVDS)*
J5	PL24A	7	LDQ21	T
GND	GNDIO7	-		
J7	PL24B	7	LDQ21	C
J4	PL25A	7	LDQ29	T (LVDS)*
J3	PL25B	7	LDQ29	C (LVDS)*
K6	PL26A	7	LDQ29	T
K8	PL26B	7	LDQ29	C
VCCIO	VCCIO7	7		
K2	PL27A	7	LDQ29	T (LVDS)*

LFE2-70E/SE Logic Signal Connections: 900 fpBGA (Cont.)

LFE2-70E/SE				
Ball Number	Ball/Pad Function	Bank	Dual Function	Differential
K1	PL27B	7	LDQ29	C (LVDS)*
K5	PL28A	7	LDQ29	T
K7	PL28B	7	LDQ29	C
GND	GNDIO7	-		
K4	PL29A	7	LDQS29	T (LVDS)*
K3	PL29B	7	LDQ29	C (LVDS)*
L8	PL30A	7	LDQ29	T
VCCIO	VCCIO7	7		
L6	PL30B	7	LDQ29	C
L2	PL31A	7	LDQ29	T (LVDS)*
L1	PL31B	7	LDQ29	C (LVDS)*
L7	PL32A	7	LDQ29	T
GND	GNDIO7	-		
L5	PL32B	7	LDQ29	C
L4	PL33A	7	LDQ37	T (LVDS)*
L3	PL33B	7	LDQ37	C (LVDS)*
M8	PL34A	7	LDQ37	T
M6	PL34B	7	LDQ37	C
VCCIO	VCCIO7	7		
M2	PL35A	7	LDQ37	T (LVDS)*
M1	PL35B	7	LDQ37	C (LVDS)*
M7	PL36A	7	LDQ37	T
M5	PL36B	7	LDQ37	C
GND	GNDIO7	-		
M4	PL37A	7	LDQS37	T (LVDS)*
M3	PL37B	7	LDQ37	C (LVDS)*
N6	PL38A	7	LUM0_SPLLT_IN_A/LDQ37	T
VCCIO	VCCIO7	7		
N8	PL38B	7	LUM0_SPLLC_IN_A/LDQ37	C
N5	PL39A	7	LUM0_SPLLT_FB_A/LDQ37	T
N7	PL39B	7	LUM0_SPLLC_FB_A/LDQ37	C
GND	GNDIO7	-		
VCCIO	VCCIO7	7		
T9	PL50A	7	LDQ54	
R9	PL51A	7	LDQ54	T
P7	PL51B	7	LDQ54	C
VCCIO	VCCIO7	7		
N2	PL52A	7	LDQ54	T (LVDS)*
N1	PL52B	7	LDQ54	C (LVDS)*
P6	PL53A	7	LDQ54	T
P5	PL53B	7	LDQ54	C
GND	GNDIO7	-		
P4	PL54A	7	LDQS54	T (LVDS)*

LFE2-70E/SE Logic Signal Connections: 900 fpBGA (Cont.)

LFE2-70E/SE				
Ball Number	Ball/Pad Function	Bank	Dual Function	Differential
P3	PL54B	7	LDQ54	C (LVDS)*
R6	PL55A	7	LDQ54	T
VCCIO	VCCIO7	7		
R8	PL55B	7	LDQ54	C
P2	PL56A	7	LDQ54	T (LVDS)*
P1	PL56B	7	LDQ54	C (LVDS)*
R5	PL57A	7	PCLKT7_0/LDQ54	T
GND	GNDIO7	-		
R7	PL57B	7	PCLKC7_0/LDQ54	C
R4	PL59A	6	PCLKT6_0/LDQ63	T (LVDS)*
R3	PL59B	6	PCLKC6_0/LDQ63	C (LVDS)*
T5	PL60A	6	VREF2_6/LDQ63	T
T7	PL60B	6	VREF1_6/LDQ63	C
T3	PL61A	6	LDQ63	T (LVDS)*
VCCIO	VCCIO6	6		
T4	PL61B	6	LDQ63	C (LVDS)*
T6	PL62A	6	LDQ63	T
T8	PL62B	6	LDQ63	C
T2	PL63A	6	LDQS63	T (LVDS)*
GND	GNDIO6	-		
T1	PL63B	6	LDQ63	C (LVDS)*
U7	PL64A	6	LDQ63	T
U5	PL64B	6	LDQ63	C
VCCIO	VCCIO6	6		
U4	PL65A	6	LDQ63	T (LVDS)*
U3	PL65B	6	LDQ63	C (LVDS)*
U8	PL66A	6	LDQ63	T
U6	PL66B	6	LDQ63	C
GND	GNDIO6	-		
U2	PL67A	6	LDQ71	T (LVDS)*
U1	PL67B	6	LDQ71	C (LVDS)*
V7	PL68A	6	LDQ71	T
V5	PL68B	6	LDQ71	C
VCCIO	VCCIO6	6		
V2	PL69A	6	LDQ71	T (LVDS)*
V1	PL69B	6	LDQ71	C (LVDS)*
V8	PL70A	6	LDQ71	T
V6	PL70B	6	LDQ71	C
GND	GNDIO6	-		
W1	PL71A	6	LDQS71	T (LVDS)*
W2	PL71B	6	LDQ71	C (LVDS)*
W5	PL72A	6	LDQ71	T
VCCIO	VCCIO6	6		

LFE2-70E/SE Logic Signal Connections: 900 fpBGA (Cont.)

LFE2-70E/SE				
Ball Number	Ball/Pad Function	Bank	Dual Function	Differential
W7	PL72B	6	LDQ71	C
W4	PL73A	6	LLM0_GDLLT_IN_A**/LDQ71	T (LVDS)*
W3	PL73B	6	LLM0_GDLLC_IN_A**/LDQ71	C (LVDS)*
W6	PL74A	6	LLM0_GDLLT_FB_A/LDQ71	T
GND	GNDIO6	-		
W8	PL74B	6	LLM0_GDLLC_FB_D/LDQ71	C
Y8	LLM0_PLLCAP	6		
Y1	PL76A	6	LLM0_GPLLT_IN_A**/LDQ80	T (LVDS)*
Y2	PL76B	6	LLM0_GPLLC_IN_A**/LDQ80	C (LVDS)*
Y5	PL77A	6	LLM0_GPLLT_FB_A/LDQ80	T
Y6	PL77B	6	LLM0_GPLLC_FB_A/LDQ80	C
Y4	PL78A	6	LDQ80	T (LVDS)*
VCCIO	VCCIO6	6		
Y3	PL78B	6	LDQ80	C (LVDS)*
AA6	PL79A	6	LDQ80	T
AA8	PL79B	6	LDQ80	C
AA2	PL80A	6	LDQS80	T (LVDS)*
GND	GNDIO6	-		
AA1	PL80B	6	LDQ80	C (LVDS)*
AA7	PL81A	6	LDQ80	T
AA5	PL81B	6	LDQ80	C
VCCIO	VCCIO6	6		
AA4	PL82A	6	LDQ80	T (LVDS)*
AA3	PL82B	6	LDQ80	C (LVDS)*
AB7	PL83A	6	LDQ80	T
AB5	PL83B	6	LDQ80	C
GND	GNDIO6	-		
AB2	PL84A	6	LDQ88	T (LVDS)*
AB1	PL84B	6	LDQ88	C (LVDS)*
AB8	PL85A	6	LDQ88	T
AB6	PL85B	6	LDQ88	C
VCCIO	VCCIO6	6		
AB4	PL86A	6	LDQ88	T (LVDS)*
AB3	PL86B	6	LDQ88	C (LVDS)*
AC7	PL87A	6	LDQ88	T
AC5	PL87B	6	LDQ88	C
GND	GNDIO6	-		
AC2	PL88A	6	LDQS88	T (LVDS)*
AC1	PL88B	6	LDQ88	C (LVDS)*
AC6	PL89A	6	LDQ88	T
VCCIO	VCCIO6	6		
AD6	PL89B	6	LDQ88	C
AD1	PL90A	6	LDQ88	T (LVDS)*

LFE2-70E/SE Logic Signal Connections: 900 fpBGA (Cont.)

LFE2-70E/SE				
Ball Number	Ball/Pad Function	Bank	Dual Function	Differential
AD2	PL90B	6	LDQ88	C (LVDS)*
AD7	PL91A	6	LDQ88	T
GND	GNDIO6	-		
AB9	PL91B	6	LDQ88	C
AD5	TCK	-		
AE7	TDI	-		
AD4	TMS	-		
AA9	TDO	-		
AD3	VCCJ	-		
AC8	PB2A	5	VREF2_5/BDQ6	T
AE8	PB2B	5	VREF1_5/BDQ6	C
AD8	PB3A	5	BDQ6	T
AF8	PB3B	5	BDQ6	C
AG7	PB4A	5	BDQ6	T
VCCIO	VCCIO5	5		
AH7	PB4B	5	BDQ6	C
AC9	PB5A	5	BDQ6	T
AE9	PB5B	5	BDQ6	C
AD9	PB6A	5	BDQS6	T
GND	GNDIO5	-		
AF9	PB6B	5	BDQ6	C
AB10	PB7A	5	BDQ6	T
AA10	PB7B	5	BDQ6	C
AJ7	PB8A	5	BDQ6	T
VCCIO	VCCIO5	5		
AK7	PB8B	5	BDQ6	C
AC10	PB9A	5	BDQ6	T
AE10	PB9B	5	BDQ6	C
AJ8	PB10A	5	BDQ6	T
GND	GNDIO5	-		
AK8	PB10B	5	BDQ6	C
AF6	PB11A	5	BDQ15	T
AF7	PB11B	5	BDQ15	C
AG5	PB12A	5	BDQ15	T
AH5	PB12B	5	BDQ15	C
AG6	PB13A	5	BDQ15	T
AH6	PB13B	5	BDQ15	C
VCCIO	VCCIO5	5		
AJ4	PB14A	5	BDQ15	T
AK4	PB14B	5	BDQ15	C
GND	GNDIO5	-		
AJ5	PB15A	5	BDQS15	T
AK5	PB15B	5	BDQ15	C

LFE2-70E/SE Logic Signal Connections: 900 fpBGA (Cont.)

LFE2-70E/SE				
Ball Number	Ball/Pad Function	Bank	Dual Function	Differential
AJ6	PB16A	5	BDQ15	T
AK6	PB16B	5	BDQ15	C
VCCIO	VCCIO5	5		
GND	GNDIO5	-		
AD10	PB29A	5	BDQ33	T
AF10	PB29B	5	BDQ33	C
AC11	PB30A	5	BDQ33	T
AD11	PB30B	5	BDQ33	C
AG9	PB31A	5	BDQ33	T
AH9	PB31B	5	BDQ33	C
VCCIO	VCCIO5	99		
AE11	PB32A	5	BDQ33	T
AG10	PB32B	5	BDQ33	C
GND	GNDIO5	-		
AJ9	PB33A	5	BDQS33	T
AK9	PB33B	5	BDQ33	C
AF11	PB34A	5	BDQ33	T
AH10	PB34B	5	BDQ33	C
AC12	PB35A	5	BDQ33	T
AE12	PB35B	5	BDQ33	C
VCCIO	VCCIO5	5		
AD12	PB36A	5	BDQ33	T
AF12	PB36B	5	BDQ33	C
AJ10	PB37A	5	BDQ33	T
AK10	PB37B	5	BDQ33	C
GND	GNDIO5	-		
AG11	PB38A	5	BDQ42	T
AH11	PB38B	5	BDQ42	C
AE13	PB39A	5	BDQ42	T
AC13	PB39B	5	BDQ42	C
AF13	PB40A	5	BDQ42	T
VCCIO	VCCIO5	5		
AD13	PB40B	5	BDQ42	C
AJ11	PB41A	5	BDQ42	T
AK11	PB41B	5	BDQ42	C
AD14	PB42A	5	BDQS42	T
GND	GNDIO5	-		
AC14	PB42B	5	BDQ42	C
AG12	PB43A	5	BDQ42	T
AE14	PB43B	5	BDQ42	C
AJ12	PB44A	5	BDQ42	T
VCCIO	VCCIO5	5		
AK12	PB44B	5	BDQ42	C

LFE2-70E/SE Logic Signal Connections: 900 fpBGA (Cont.)

LFE2-70E/SE				
Ball Number	Ball/Pad Function	Bank	Dual Function	Differential
AH12	PB45A	5	BDQ42	T
AF14	PB45B	5	BDQ42	C
AJ13	PB46A	5	BDQ42	T
GND	GNDIO5	-		
AK13	PB46B	5	BDQ42	C
AB15	PB47A	5	BDQ51	T
AD15	PB47B	5	BDQ51	C
AE15	PB48A	5	BDQ51	T
AF15	PB48B	5	BDQ51	C
AG15	PB49A	5	BDQ51	T
AG14	PB49B	5	BDQ51	C
VCCIO	VCCIO5	5		
AH15	PB50A	5	BDQ51	T
AH14	PB50B	5	BDQ51	C
GND	GNDIO5	-		
AJ14	PB51A	5	BDQS51	T
AK14	PB51B	5	BDQ51	C
AD16	PB52A	5	BDQ51	T
AF16	PB52B	5	BDQ51	C
AJ15	PB53A	5	PCLKT5_0/BDQ51	T
AK15	PB53B	5	PCLKC5_0/BDQ51	C
VCCIO	VCCIO5	5		
GND	GNDIO5	-		
AE16	PB58A	4	PCLKT4_0/BDQ60	T
VCCIO	VCCIO4	4		
AC15	PB58B	4	PCLKC4_0/BDQ60	C
AJ16	PB59A	4	BDQ60	T
AK16	PB59B	4	BDQ60	C
AC16	PB60A	4	BDQS60	T
GND	GNDIO4	-		
AB16	PB60B	4	BDQ60	C
AH17	PB61A	4	BDQ60	T
AG17	PB61B	4	BDQ60	C
AF17	PB62A	4	BDQ60	T
VCCIO	VCCIO4	4		
AD17	PB62B	4	BDQ60	C
AE17	PB63A	4	BDQ60	T
AC17	PB63B	4	BDQ60	C
AJ17	PB64A	4	BDQ60	T
GND	GNDIO4	-		
AK17	PB64B	4	BDQ60	C
AK18	PB65A	4	BDQ69	T
AJ18	PB65B	4	BDQ69	C

LFE2-70E/SE Logic Signal Connections: 900 fpBGA (Cont.)

LFE2-70E/SE				
Ball Number	Ball/Pad Function	Bank	Dual Function	Differential
AD18	PB66A	4	BDQ69	T
AF18	PB66B	4	BDQ69	C
AC18	PB67A	4	BDQ69	T
AE18	PB67B	4	BDQ69	C
VCCIO	VCCIO4	4		
AG19	PB68A	4	BDQ69	T
AH19	PB68B	4	BDQ69	C
GND	GNDIO4	-		
AE19	PB69A	4	BDQS69	T
AF19	PB69B	4	BDQ69	C
AC19	PB70A	4	BDQ69	T
AD19	PB70B	4	BDQ69	C
AJ19	PB71A	4	BDQ69	T
AK19	PB71B	4	BDQ69	C
VCCIO	VCCIO4	4		
AF20	PB72A	4	BDQ69	T
AH20	PB72B	4	BDQ69	C
AE20	PB73A	4	BDQ69	T
AG20	PB73B	4	BDQ69	C
GND	GNDIO4	-		
AD20	PB74A	4	BDQ78	T
AC20	PB74B	4	BDQ78	C
AH21	PB75A	4	BDQ78	T
AF21	PB75B	4	BDQ78	C
AJ20	PB76A	4	BDQ78	T
VCCIO	VCCIO4	4		
AK20	PB76B	4	BDQ78	C
AG21	PB77A	4	BDQ78	T
AE21	PB77B	4	BDQ78	C
AD21	PB78A	4	BDQS78	T
GND	GNDIO4	-		
AC21	PB78B	4	BDQ78	C
AD22	PB79A	4	BDQ78	T
AB21	PB79B	4	BDQ78	C
AJ21	PB80A	4	BDQ78	T
VCCIO	VCCIO4	4		
AK21	PB80B	4	BDQ78	C
GND	GNDIO4	-		
VCCIO	VCCIO4	4		
AJ25	PB87A	4	BDQS87***	T
AK24	PB87B	4	BDQ87	C
AJ24	PB88A	4	BDQ87	T
AK25	PB88B	4	BDQ87	C

LFE2-70E/SE Logic Signal Connections: 900 fpBGA (Cont.)

LFE2-70E/SE				
Ball Number	Ball/Pad Function	Bank	Dual Function	Differential
AH24	PB89A	4	BDQ87	T
AH25	PB89B	4	BDQ87	C
VCCIO	VCCIO4	4		
AJ26	PB90A	4	BDQ87	T
AK26	PB90B	4	BDQ87	C
AF25	PB91A	4	BDQ87	T
AG25	PB91B	4	BDQ87	C
GND	GNDIO4	-		
AK22	PB92A	4	BDQ96	T
AJ22	PB92B	4	BDQ96	C
AE22	PB93A	4	BDQ96	T
AF22	PB93B	4	BDQ96	C
AG22	PB94A	4	BDQ96	T
VCCIO	VCCIO4	4		
AH22	PB94B	4	BDQ96	C
AG24	PB95A	4	BDQ96	T
AG23	PB95B	4	BDQ96	C
AE23	PB96A	4	BDQS96	
GND	GNDIO4	-		
AC22	PB97A	4	BDQ96	
AJ23	PB98A	4	BDQ96	T
VCCIO	VCCIO4	4		
AK23	PB98B	4	BDQ96	C
AD24	PB99A	4	BDQ96	T
AF24	PB99B	4	BDQ96	C
AC23	PB100A	4	VREF2_4/BDQ96	T
GND	GNDIO4	-		
AE24	PB100B	4	VREF1_4/BDQ96	C
AE25	CFG2	8		
AB22	CFG1	8		
AE26	CFG0	8		
AA22	PROGRAMN	8		
AD25	CCLK	8		
AD26	INITN	8		
AC24	DONE	8		
GND	GNDIO4	-		
AC25	PR90B	8	WRITEN	C
AE27	PR90A	8	CS1N	T
AC26	PR89B	8	CSN	C
AE28	PR89A	8	D0/SPIFASTN	T
VCCIO	VCCIO8	8		
AD27	PR88B	8	D1	C
AD28	PR88A	8	D2	T

LFE2-70E/SE Logic Signal Connections: 900 fpBGA (Cont.)

LFE2-70E/SE				
Ball Number	Ball/Pad Function	Bank	Dual Function	Differential
AB24	PR87B	8	D3	C
GND	GNDIO4	-		
AB23	PR87A	8	D4	T
AB25	PR86B	8	D5	C
AB26	PR86A	8	D6	T
AC27	PR85B	8	D7	C
VCCIO	VCCIO8	8		
AB27	PR85A	8	DI/CSSPION	T
AD29	PR84B	8	DOUT/CSON	C
AD30	PR84A	8	BUSY/SISPI	T
AA25	PR83B	3	RDQ80	C
GND	GNDIO3	-		
AA23	PR83A	3	RDQ80	T
AC29	PR82B	3	RDQ80	C (LVDS)*
AC30	PR82A	3	RDQ80	T (LVDS)*
AA26	PR81B	3	RDQ80	C
VCCIO	VCCIO3	3		
AA24	PR81A	3	RDQ80	T
AB29	PR80B	3	RDQ80	C (LVDS)*
AB30	PR80A	3	RDQS80	T (LVDS)*
GND	GNDIO3	-		
Y23	PR79B	3	RDQ80	C
Y25	PR79A	3	RDQ80	T
AA27	PR78B	3	RDQ80	C (LVDS)*
AA28	PR78A	3	RDQ80	T (LVDS)*
VCCIO	VCCIO3	3		
Y24	PR77B	3	RLM0_GPLL_C_FB_A/RDQ80	C
Y26	PR77A	3	RLM0_GPLLT_FB_A/RDQ80	T
AA29	PR76B	3	RLM0_GPLL_C_IN_A**/RDQ80	C (LVDS)*
AA30	PR76A	3	RLM0_GPLLT_IN_A**/RDQ80	T (LVDS)*
R22	RLM0_PLLCAP	3		
W23	PR74B	3	RLM0_GDLL_C_FB_A/RDQ71	C
W25	PR74A	3	RLM0_GDLLT_FB_A/RDQ71	T
GND	GNDIO3	-		
Y27	PR73B	3	RLM0_GDLL_C_IN_A**/RDQ71	C (LVDS)*
Y28	PR73A	3	RLM0_GDLLT_IN_A**/RDQ71	T (LVDS)*
W24	PR72B	3	RDQ71	C
W26	PR72A	3	RDQ71	T
VCCIO	VCCIO3	3		
Y29	PR71B	3	RDQ71	C (LVDS)*
Y30	PR71A	3	RDQS71	T (LVDS)*
V25	PR70B	3	RDQ71	C
GND	GNDIO3	-		

LFE2-70E/SE Logic Signal Connections: 900 fpBGA (Cont.)

LFE2-70E/SE				
Ball Number	Ball/Pad Function	Bank	Dual Function	Differential
V23	PR70A	3	RDQ71	T
W27	PR69B	3	RDQ71	C (LVDS)*
W28	PR69A	3	RDQ71	T (LVDS)*
V26	PR68B	3	RDQ71	C
VCCIO	VCCIO3	3		
V24	PR68A	3	RDQ71	T
W29	PR67B	3	RDQ71	C (LVDS)*
W30	PR67A	3	RDQ71	T (LVDS)*
U25	PR66B	3	RDQ63	C
GND	GNDIO3	-		
U23	PR66A	3	RDQ63	T
V29	PR65B	3	RDQ63	C (LVDS)*
V30	PR65A	3	RDQ63	T (LVDS)*
U26	PR64B	3	RDQ63	C
VCCIO	VCCIO3	3		
U24	PR64A	3	RDQ63	T
U27	PR63B	3	RDQ63	C (LVDS)*
U28	PR63A	3	RDQS63	T (LVDS)*
GND	GNDIO3	-		
T23	PR62B	3	RDQ63	C
T25	PR62A	3	RDQ63	T
U29	PR61B	3	RDQ63	C (LVDS)*
U30	PR61A	3	RDQ63	T (LVDS)*
VCCIO	VCCIO3	3		
T24	PR60B	3	VREF2_3/RDQ63	C
T26	PR60A	3	VREF1_3/RDQ63	T
T27	PR59B	3	PCLKC3_0/RDQ63	C (LVDS)*
T28	PR59A	3	PCLKT3_0/RDQ63	T (LVDS)*
R24	PR57B	2	PCLKC2_0/RDQ54	C
R26	PR57A	2	PCLKT2_0/RDQ54	T
GND	GNDIO2	-		
T29	PR56B	2	RDQ54	C (LVDS)*
T30	PR56A	2	RDQ54	T (LVDS)*
R23	PR55B	2	RDQ54	C
R25	PR55A	2	RDQ54	T
VCCIO	VCCIO2	2		
R27	PR54B	2	RDQ54	C (LVDS)*
R28	PR54A	2	RDQS54	T (LVDS)*
P26	PR53B	2	RDQ54	C
GND	GNDIO2	-		
P24	PR53A	2	RDQ54	T
R29	PR52B	2	RDQ54	C (LVDS)*
R30	PR52A	2	RDQ54	T (LVDS)*

LFE2-70E/SE Logic Signal Connections: 900 fpBGA (Cont.)

LFE2-70E/SE				
Ball Number	Ball/Pad Function	Bank	Dual Function	Differential
P25	PR51B	2	RDQ54	C
VCCIO	VCCIO2	2		
P23	PR51A	2	RDQ54	T
P27	PR50B	2	RDQ54	C (LVDS)*
P28	PR50A	2	RDQ54	T (LVDS)*
GND	GNDIO2	-		
VCCIO	VCCIO2	2		
N24	PR39B	2	RUM0_SPLLC_FB_A/RDQ37	C
N26	PR39A	2	RUM0_SPLLT_FB_A/RDQ37	T
N23	PR38B	2	RUM0_SPLLC_IN_A/RDQ37	C
N25	PR38A	2	RUM0_SPLLT_IN_A/RDQ37	T
VCCIO	VCCIO2	2		
P29	PR37B	2	RDQ37	C (LVDS)*
P30	PR37A	2	RDQS37	T (LVDS)*
M26	PR36B	2	RDQ37	C
GND	GNDIO2	-		
M24	PR36A	2	RDQ37	T
N29	PR35B	2	RDQ37	C (LVDS)*
N30	PR35A	2	RDQ37	T (LVDS)*
M25	PR34B	2	RDQ37	C
VCCIO	VCCIO2	2		
M23	PR34A	2	RDQ37	T
M27	PR33B	2	RDQ37	C (LVDS)*
M28	PR33A	2	RDQ37	T (LVDS)*
L26	PR32B	2	RDQ29	C
GND	GNDIO2	-		
L24	PR32A	2	RDQ29	T
M29	PR31B	2	RDQ29	C (LVDS)*
M30	PR31A	2	RDQ29	T (LVDS)*
L25	PR30B	2	RDQ29	C
VCCIO	VCCIO2	2		
L23	PR30A	2	RDQ29	T
L27	PR29B	2	RDQ29	C (LVDS)*
L28	PR29A	2	RDQS29	T (LVDS)*
GND	GNDIO2	-		
K24	PR28B	2	RDQ29	C
K26	PR28A	2	RDQ29	T
L29	PR27B	2	RDQ29	C (LVDS)*
L30	PR27A	2	RDQ29	T (LVDS)*
VCCIO	VCCIO2	2		
K23	PR26B	2	RDQ29	C
K25	PR26A	2	RDQ29	T
K27	PR25B	2	RDQ29	C (LVDS)*

LFE2-70E/SE Logic Signal Connections: 900 fpBGA (Cont.)

LFE2-70E/SE				
Ball Number	Ball/Pad Function	Bank	Dual Function	Differential
K28	PR25A	2	RDQ29	T (LVDS)*
J24	PR24B	2	RDQ21	C
J26	PR24A	2	RDQ21	T
GND	GNDIO2	-		
K29	PR23B	2	RDQ21	C (LVDS)*
K30	PR23A	2	RDQ21	T (LVDS)*
J23	PR22B	2	RDQ21	C
J25	PR22A	2	RDQ21	T
VCCIO	VCCIO2	99		
J27	PR21B	2	RDQ21	C (LVDS)*
J28	PR21A	2	RDQS21	T (LVDS)*
H26	PR20B	2	RDQ21	C
GND	GNDIO2	-		
H24	PR20A	2	RDQ21	T
J29	PR19B	2	RDQ21	C (LVDS)*
J30	PR19A	2	RDQ21	T (LVDS)*
H25	PR18B	2	RDQ21	C
VCCIO	VCCIO2	2		
H23	PR18A	2	RDQ21	T
G27	PR15B	2	RUM1_SPLLC_FB_A/RDQ12	C
GND	GNDIO2	-		
H27	PR15A	2	RUM1_SPLLT_FB_A/RDQ12	T
G29	PR14B	2	RUM1_SPLLC_IN_A/RDQ12	C (LVDS)*
G28	PR14A	2	RUM1_SPLLT_IN_A/RDQ12	T (LVDS)*
VCCIO	VCCIO2	2		
GND	GNDIO2	-		
G26	PR6B	2		C (LVDS)*
G25	PR6A	2		T (LVDS)*
G30	PR5B	2		C
F30	PR5A	2		T
VCCIO	VCCIO2	2		
F26	PR4B	2		C (LVDS)*
F27	PR4A	2		T (LVDS)*
F29	PR3B	2		C
GND	GNDIO2	-		
F28	PR3A	2		T
H29	PR2B	2	VREF2_2	C (LVDS)*
H30	PR2A	2	VREF1_2	T (LVDS)*
VCCIO	VCCIO2	2		
B26	PT100B	1	VREF2_1	C
A26	PT100A	1	VREF1_1	T
GND	GNDIO1	-		
C25	PT99B	1		C

LFE2-70E/SE Logic Signal Connections: 900 fpBGA (Cont.)

LFE2-70E/SE				
Ball Number	Ball/Pad Function	Bank	Dual Function	Differential
D25	PT99A	1		T
J22	PT98B	1		C
J21	PT98A	1		T
VCCIO	VCCIO1	1		
B25	PT97B	1		C
A25	PT97A	1		T
E24	PT96B	1		C
F24	PT96A	1		T
GND	GNDIO1	-		
F23	PT95B	1		C
H22	PT95A	1		T
D24	PT94B	1		C
C24	PT94A	1		T
VCCIO	VCCIO1	1		
E23	PT93B	1		C
G23	PT93A	1		T
B24	PT92B	1		C
A24	PT92A	1		T
C27	PT91B	1		C
GND	GNDIO1	-		
D27	PT91A	1		T
C26	PT90B	1		C
D26	PT90A	1		T
A27	PT89B	1		C
VCCIO	VCCIO1	1		
B27	PT89A	1		T
A28	PT88B	1		C
B28	PT88A	1		T
A29	PT87B	1		C
B29	PT87A	1		T
GND	GNDIO1	-		
VCCIO	VCCIO1	1		
H21	PT80B	1		C
F22	PT80A	1		T
VCCIO	VCCIO1	1		
B23	PT79B	1		C
A23	PT79A	1		T
G24	PT78B	1		C
E22	PT78A	1		T
GND	GNDIO1	-		
D22	PT77B	1		C
C22	PT77A	1		T
G22	PT76B	1		C

LFE2-70E/SE Logic Signal Connections: 900 fpBGA (Cont.)

LFE2-70E/SE				
Ball Number	Ball/Pad Function	Bank	Dual Function	Differential
E21	PT76A	1		T
VCCIO	VCCIO1	1		
B22	PT75B	1		C
A22	PT75A	1		T
H20	PT74B	1		C
F21	PT74A	1		T
F20	PT73B	1		C
GND	GNDIO1	-		
H19	PT73A	1		T
D21	PT72B	1		C
C21	PT72A	1		T
E20	PT71B	1		C
VCCIO	VCCIO1	1		
G21	PT71A	1		T
B21	PT70B	1		C
A21	PT70A	1		T
F19	PT69B	1		C
G20	PT69A	1		T
E19	PT68B	1		C
GND	GNDIO1	-		
G19	PT68A	1		T
D20	PT67B	1		C
VCCIO	VCCIO1	1		
C20	PT67A	1		T
B20	PT66B	1		C
A20	PT66A	1		T
F18	PT65B	1		C
H18	PT65A	1		T
D19	PT64B	1		C
C19	PT64A	1		T
GND	GNDIO1	-		
G18	PT63B	1		C
E18	PT63A	1		T
H17	PT62B	1		C
F17	PT62A	1		T
VCCIO	VCCIO1	1		
G17	PT61B	1		C
E17	PT61A	1		T
B19	PT60B	1		C
A19	PT60A	1		T
GND	GNDIO1	-		
D17	PT59B	1		C
B18	PT59A	1		T

LFE2-70E/SE Logic Signal Connections: 900 fpBGA (Cont.)

LFE2-70E/SE				
Ball Number	Ball/Pad Function	Bank	Dual Function	Differential
C17	PT58B	1		C
A18	PT58A	1		T
VCCIO	VCCIO1	1		
H16	PT57B	1	PCLKC1_0	C
F16	PT57A	1	PCLKT1_0	T
K16	XRES	1		
E16	PT55B	0	PCLKC0_0	C
GND	GNDIO0	-		
G16	PT55A	0	PCLKT0_0	T
B17	PT54B	0		C
A17	PT54A	0		T
J15	PT53B	0		C
VCCIO	VCCIO0	0		
J16	PT53A	0		T
C16	PT52B	0		C
D16	PT52A	0		T
F15	PT51B	0		C
H15	PT51A	0		T
E15	PT50B	0		C
GND	GNDIO0	-		
G15	PT50A	0		T
C15	PT49B	0		C
VCCIO	VCCIO0	0		
D15	PT49A	0		T
B16	PT48B	0		C
A16	PT48A	0		T
E14	PT47B	0		C
G14	PT47A	0		T
B15	PT46B	0		C
A15	PT46A	0		T
GND	GNDIO0	-		
H14	PT45B	0		C
F14	PT45A	0		T
D14	PT44B	0		C
C14	PT44A	0		T
VCCIO	VCCIO0	0		
G13	PT43B	0		C
E13	PT43A	0		T
B14	PT42B	0		C
A14	PT42A	0		T
GND	GNDIO0	-		
H13	PT41B	0		C
F13	PT41A	0		T

LFE2-70E/SE Logic Signal Connections: 900 fpBGA (Cont.)

LFE2-70E/SE				
Ball Number	Ball/Pad Function	Bank	Dual Function	Differential
G12	PT40B	0		C
E12	PT40A	0		T
VCCIO	VCCIO0	0		
B13	PT39B	0		C
A13	PT39A	0		T
H12	PT38B	0		C
F12	PT38A	0		T
C12	PT37B	0		C
GND	GNDIO0	-		
D12	PT37A	0		T
B12	PT36B	0		C
A12	PT36A	0		T
E11	PT35B	0		C
VCCIO	VCCIO0	0		
G11	PT35A	0		T
F11	PT34B	0		C
H11	PT34A	0		T
C11	PT33B	0		C
D11	PT33A	0		T
B11	PT32B	0		C
GND	GNDIO0	-		
A11	PT32A	0		T
E10	PT31B	0		C
VCCIO	VCCIO0	0		
G10	PT31A	0		T
F10	PT30B	0		C
H10	PT30A	0		T
D10	PT29B	0		C
C10	PT29A	0		T
GND	GNDIO0	-		
VCCIO	VCCIO0	0		
A7	PT16B	0		C
B7	PT16A	0		T
A6	PT15B	0		C
B6	PT15A	0		T
C7	PT14B	0		C
GND	GNDIO0	-		
D7	PT14A	0		T
D8	PT13B	0		C
VCCIO	VCCIO0	0		
E7	PT13A	0		T
C6	PT12B	0		C
D6	PT12A	0		T

LFE2-70E/SE Logic Signal Connections: 900 fpBGA (Cont.)

LFE2-70E/SE				
Ball Number	Ball/Pad Function	Bank	Dual Function	Differential
C5	PT11B	0		C
D5	PT11A	0		T
E9	PT10B	0		C
G9	PT10A	0		T
GND	GNDIO0	-		
B10	PT9B	0		C
A10	PT9A	0		T
D9	PT8B	0		C
C9	PT8A	0		T
VCCIO	VCCIO0	0		
F9	PT7B	0		C
H9	PT7A	0		T
B9	PT6B	0		C
A9	PT6A	0		T
GND	GNDIO0	-		
E8	PT5B	0		C
G8	PT5A	0		T
A8	PT4B	0		C
B8	PT4A	0		T
VCCIO	VCCIO0	0		
F8	PT3B	0		C
F7	PT3A	0		T
J10	PT2B	0	VREF2_0	C
J9	PT2A	0	VREF1_0	T
AA11	VCC	-		
AA20	VCC	-		
K11	VCC	-		
K21	VCC	-		
K22	VCC	-		
L11	VCC	-		
L12	VCC	-		
L13	VCC	-		
L18	VCC	-		
L19	VCC	-		
L20	VCC	-		
M11	VCC	-		
M20	VCC	-		
N11	VCC	-		
N20	VCC	-		
V11	VCC	-		
V20	VCC	-		
W11	VCC	-		
W20	VCC	-		

LFE2-70E/SE Logic Signal Connections: 900 fpBGA (Cont.)

LFE2-70E/SE				
Ball Number	Ball/Pad Function	Bank	Dual Function	Differential
Y10	VCC	-		
Y11	VCC	-		
Y12	VCC	-		
Y13	VCC	-		
Y18	VCC	-		
Y19	VCC	-		
Y20	VCC	-		
J13	VCCIO0	0		
J14	VCCIO0	0		
K12	VCCIO0	0		
K13	VCCIO0	0		
K14	VCCIO0	0		
K15	VCCIO0	0		
J17	VCCIO1	1		
J18	VCCIO1	1		
J20	VCCIO1	1		
K17	VCCIO1	1		
K18	VCCIO1	1		
K20	VCCIO1	1		
L21	VCCIO2	2		
M21	VCCIO2	2		
M22	VCCIO2	2		
N21	VCCIO2	2		
N22	VCCIO2	2		
R21	VCCIO2	2		
U21	VCCIO3	3		
U22	VCCIO3	3		
V21	VCCIO3	3		
V22	VCCIO3	3		
W21	VCCIO3	3		
Y22	VCCIO3	3		
AA16	VCCIO4	4		
AA17	VCCIO4	4		
AA18	VCCIO4	4		
AA19	VCCIO4	4		
AB17	VCCIO4	4		
AB18	VCCIO4	4		
AA12	VCCIO5	5		
AA13	VCCIO5	5		
AA14	VCCIO5	5		
AB12	VCCIO5	5		
AB13	VCCIO5	5		
AB14	VCCIO5	5		

LFE2-70E/SE Logic Signal Connections: 900 fpBGA (Cont.)

LFE2-70E/SE				
Ball Number	Ball/Pad Function	Bank	Dual Function	Differential
U10	VCCIO6	6		
U9	VCCIO6	6		
V10	VCCIO6	6		
W10	VCCIO6	6		
W9	VCCIO6	6		
Y9	VCCIO6	6		
L10	VCCIO7	7		
L9	VCCIO7	7		
M10	VCCIO7	7		
N10	VCCIO7	7		
P10	VCCIO7	7		
R10	VCCIO7	7		
AA21	VCCIO8	8		
Y21	VCCIO8	8		
AA15	VCCAUX	-		
AB11	VCCAUX	-		
AB19	VCCAUX	-		
AB20	VCCAUX	-		
J11	VCCAUX	-		
J12	VCCAUX	-		
J19	VCCAUX	-		
K19	VCCAUX	-		
L22	VCCAUX	-		
M9	VCCAUX	-		
N9	VCCAUX	-		
P21	VCCAUX	-		
P9	VCCAUX	-		
T10	VCCAUX	-		
T21	VCCAUX	-		
V9	VCCAUX	-		
W22	VCCAUX	-		
A1	GND	-		
A30	GND	-		
AC28	GND	-		
AC3	GND	-		
AH13	GND	-		
AH18	GND	-		
AH23	GND	-		
AH28	GND	-		
AH3	GND	-		
AH8	GND	-		
AK1	GND	-		
AK30	GND	-		

LFE2-70E/SE Logic Signal Connections: 900 fpBGA (Cont.)

LFE2-70E/SE				
Ball Number	Ball/Pad Function	Bank	Dual Function	Differential
C13	GND	-		
C18	GND	-		
C23	GND	-		
C28	GND	-		
C3	GND	-		
C8	GND	-		
H28	GND	-		
H3	GND	-		
L14	GND	-		
L15	GND	-		
L16	GND	-		
L17	GND	-		
M12	GND	-		
M13	GND	-		
M14	GND	-		
M15	GND	-		
M16	GND	-		
M17	GND	-		
M18	GND	-		
M19	GND	-		
N12	GND	-		
N13	GND	-		
N14	GND	-		
N15	GND	-		
N16	GND	-		
N17	GND	-		
N18	GND	-		
N19	GND	-		
N28	GND	-		
N3	GND	-		
P11	GND	-		
P12	GND	-		
P13	GND	-		
P14	GND	-		
P15	GND	-		
P16	GND	-		
P17	GND	-		
P18	GND	-		
P19	GND	-		
P20	GND	-		
R11	GND	-		
R12	GND	-		
R13	GND	-		

LFE2-70E/SE Logic Signal Connections: 900 fpBGA (Cont.)

LFE2-70E/SE				
Ball Number	Ball/Pad Function	Bank	Dual Function	Differential
R14	GND	-		
R15	GND	-		
R16	GND	-		
R17	GND	-		
R18	GND	-		
R19	GND	-		
R20	GND	-		
T11	GND	-		
T12	GND	-		
T13	GND	-		
T14	GND	-		
T15	GND	-		
T16	GND	-		
T17	GND	-		
T18	GND	-		
T19	GND	-		
T20	GND	-		
U11	GND	-		
U12	GND	-		
U13	GND	-		
U14	GND	-		
U15	GND	-		
U16	GND	-		
U17	GND	-		
U18	GND	-		
U19	GND	-		
U20	GND	-		
V12	GND	-		
V13	GND	-		
V14	GND	-		
V15	GND	-		
V16	GND	-		
V17	GND	-		
V18	GND	-		
V19	GND	-		
V28	GND	-		
V3	GND	-		
W12	GND	-		
W13	GND	-		
W14	GND	-		
W15	GND	-		
W16	GND	-		
W17	GND	-		

LFE2-70E/SE Logic Signal Connections: 900 fpBGA (Cont.)

LFE2-70E/SE				
Ball Number	Ball/Pad Function	Bank	Dual Function	Differential
W18	GND	-		
W19	GND	-		
Y14	GND	-		
Y15	GND	-		
Y16	GND	-		
Y17	GND	-		
A2	NC	-		
A3	NC	-		
A4	NC	-		
A5	NC	-		
AB28	NC	-		
AC4	NC	-		
AD23	NC	-		
AE1	NC	-		
AE2	NC	-		
AE29	NC	-		
AE3	NC	-		
AE30	NC	-		
AE4	NC	-		
AE5	NC	-		
AE6	NC	-		
AF1	NC	-		
AF2	NC	-		
AF23	NC	-		
AF26	NC	-		
AF27	NC	-		
AF28	NC	-		
AF29	NC	-		
AF3	NC	-		
AF30	NC	-		
AF4	NC	-		
AF5	NC	-		
AG1	NC	-		
AG13	NC	-		
AG16	NC	-		
AG18	NC	-		
AG2	NC	-		
AG26	NC	-		
AG27	NC	-		
AG28	NC	-		
AG29	NC	-		
AG3	NC	-		
AG30	NC	-		

LFE2-70E/SE Logic Signal Connections: 900 fpBGA (Cont.)

LFE2-70E/SE				
Ball Number	Ball/Pad Function	Bank	Dual Function	Differential
AG4	NC	-		
AG8	NC	-		
AH1	NC	-		
AH16	NC	-		
AH2	NC	-		
AH26	NC	-		
AH27	NC	-		
AH29	NC	-		
AH30	NC	-		
AH4	NC	-		
AJ1	NC	-		
AJ2	NC	-		
AJ27	NC	-		
AJ28	NC	-		
AJ29	NC	-		
AJ3	NC	-		
AJ30	NC	-		
AK2	NC	-		
AK27	NC	-		
AK28	NC	-		
AK29	NC	-		
AK3	NC	-		
B1	NC	-		
B2	NC	-		
B3	NC	-		
B30	NC	-		
B4	NC	-		
B5	NC	-		
C1	NC	-		
C2	NC	-		
C29	NC	-		
C30	NC	-		
C4	NC	-		
D13	NC	-		
D18	NC	-		
D23	NC	-		
D28	NC	-		
D29	NC	-		
D3	NC	-		
D30	NC	-		
D4	NC	-		
E25	NC	-		
E26	NC	-		

LFE2-70E/SE Logic Signal Connections: 900 fpBGA (Cont.)

LFE2-70E/SE				
Ball Number	Ball/Pad Function	Bank	Dual Function	Differential
E27	NC	-		
E28	NC	-		
E29	NC	-		
E3	NC	-		
E30	NC	-		
E4	NC	-		
E5	NC	-		
E6	NC	-		
F25	NC	-		
F5	NC	-		
F6	NC	-		
G6	NC	-		
G7	NC	-		
K10	NC	-		
K9	NC	-		
N27	NC	-		
N4	NC	-		
R1	NC	-		
R2	NC	-		
V27	NC	-		
V4	NC	-		
P22	VCCPLL	-		
P8	VCCPLL	-		
T22	VCCPLL	-		
Y7	VCCPLL	-		

* Supports true LVDS. Other differential signals must be emulated with external resistors.

** These dedicated input pins can be used for GPLLs or GDLLs within the respective quadrant.

***Due to packaging bond out option, this DQS does not have all the necessary DQ pins bonded out for a full 8-bit data width.

Note: VCCIO and GND pads are used to determine the average DC current drawn by I/Os between GND/VCCIO connections, or between the last GND/VCCIO in an I/O bank and the end of an I/O bank. The substrate pads listed in the Pin Table do not necessarily have a one to one connection with a package ball or pin.

LFE2M-20E/SE and LFE2M-35E/SE Logic Signal Connections: 256 fpBGA

LFE2M20E/SE					LFE2M35E/SE				
Ball Number	Ball/Pad Function	Bank	Dual Function	Differential	Ball/Pad Function	Bank	Dual Function	Differential	
A2	PL2A	7	LDQ6	T (LVDS)*	PL2A	7	LDQ6	T (LVDS)*	
B2	PL2B	7	LDQ6	C (LVDS)*	PL2B	7	LDQ6	C(LVDS)*	
D3	PL3A	7	LDQ6	T	PL3A	7	LDQ6	T	
C2	PL3B	7	LDQ6	C	PL3B	7	LDQ6	C	
E4	PL4A	7	LDQ6	T (LVDS)*	PL4A	7	LDQ6	T (LVDS)*	
VCCIO	VCCIO7	7			VCCIO7	7			
E5	PL4B	7	LDQ6	C (LVDS)*	PL4B	7	LDQ6	C(LVDS)*	
B1	PL5A	7	LDQ6	T	PL5A	7	LDQ6	T	
C1	PL5B	7	LDQ6	C	PL5B	7	LDQ6	C	
D2	PL6A	7	LDQS6	T (LVDS)*	PL6A	7	LDQS6	T (LVDS)*	
GNDIO	GNDIO7	-			GNDIO7	-			
D1	PL6B	7	LDQ6	C (LVDS)*	PL6B	7	LDQ6	C(LVDS)*	
E1	PL7A	7	LDQ6	T	PL7A	7	LDQ6	T	
F1	PL7B	7	LDQ6	C	PL7B	7	LDQ6	C	
VCCIO	VCCIO7	7			VCCIO7	7			
F3	PL8A	7	LDQ6	T (LVDS)*	PL8A	7	LDQ6	T (LVDS)*	
F2	PL8B	7	LDQ6	C (LVDS)*	PL8B	7	LDQ6	C(LVDS)*	
F6	PL9A	7	VREF2_7/LDQ6	T	PL9A	7	VREF2_7/LDQ6	T	
F5	PL9B	7	VREF1_7/LDQ6	C	PL9B	7	VREF1_7/LDQ6	C	
GNDIO	GNDIO7	-			GNDIO7	-			
G4	PL11A	7	LUM0_SPLLT_IN_A	T (LVDS)*	PL11A	7	LUM0_SPLLT_IN_A/LDQ15	T (LVDS)*	
G3	PL11B	7	LUM0_SPLLC_IN_A	C (LVDS)*	PL11B	7	LUM0_SPLLC_IN_A/LDQ15	C(LVDS)*	
G1	PL12A	7	LUM0_SPLLT_FB_A	T	PL12A	7	LUM0_SPLLT_FB_A/LDQ15	T	
G2	PL12B	7	LUM0_SPLLC_FB_A	C	PL12B	7	LUM0_SPLLC_FB_A/LDQ15	C	
H1	PL13A	7		T (LVDS)*	PL13A	7	LDQ15	T (LVDS)*	
VCCIO	VCCIO7	7			VCCIO7	7			
J1	PL13B	7		C (LVDS)*	PL13B	7	LDQ15	C(LVDS)*	
H2	PL14A	7		T	PL14A	7	LDQ15	T	
H3	PL14B	7		C	PL14B	7	LDQ15	C	
GNDIO	GNDIO7	-			GNDIO7	-			
VCCIO	VCCIO7	7			VCCIO7	7			
G6	PL24A	7	LDQ22	T (LVDS)*	PL34A	7	LDQ32	T (LVDS)*	
H6	PL24B	7	LDQ22	C (LVDS)*	PL34B	7	LDQ32	C(LVDS)*	
J2	PL25A	7	PCLKT7_0/LDQ22	T	PL35A	7	PCLKT7_0/LDQ32	T	
GNDIO	GNDIO7	-			GNDIO7	-			
K1	PL25B	7	PCLKC7_0/LDQ22	C	PL35B	7	PCLKC7_0/LDQ32	C	
H4	PL27A	6	PCLKT6_0	T (LVDS)*	PL37A	6	PCLKT6_0	T (LVDS)*	
H5	PL27B	6	PCLKC6_0	C (LVDS)*	PL37B	6	PCLKC6_0	C(LVDS)*	
J4	PL28A	6	VREF2_6	T	PL38A	6	VREF2_6	T	
K4	PL28B	6	VREF1_6	C	PL38B	6	VREF1_6	C	
VCCIO	VCCIO6	6			VCCIO6	6			
J6	PL31A	6	LLM1_SPLLT_IN_A	T (LVDS)*	PL41A	6	LLM2_SPLLT_IN_A	T (LVDS)*	
GNDIO	GNDIO6	-			GNDIO6	-			
J5	PL31B	6	LLM1_SPLLC_IN_A	C (LVDS)*	PL41B	6	LLM2_SPLLC_IN_A	C(LVDS)*	
K3	PL32A	6	LLM1_SPLLT_FB_A	T	PL42A	6	LLM2_SPLLT_FB_A	T	
K2	PL32B	6	LLM1_SPLLC_FB_A	C	PL42B	6	LLM2_SPLLC_FB_A	C	
VCCIO	VCCIO6	6			VCCIO6	6			
GNDIO	GNDIO6	-			GNDIO6	-			
L1	PL42A	6	LLM0_GPLLT_IN_A	T (LVDS)*	PL57A	6	LLM0_GPLLT_IN_A**/LDQS57***	T (LVDS)*	

LFE2M-20E/SE and LFE2M-35E/SE Logic Signal Connections: 256 fpBGA

LFE2M20E/SE					LFE2M35E/SE				
Ball Number	Ball/Pad Function	Bank	Dual Function	Differential	Ball/Pad Function	Bank	Dual Function	Differential	
GNDIO	GNDIO6	-			GNDIO6	-			
L2	PL42B	6	LLM0_GPLL_C_IN_A	C (LVDS)*	PL57B	6	LLM0_GPLL_C_IN_A**/LDQ57	C (LVDS)*	
L3	PL43A	6	LLM0_GPLL_T_FB_A	T	PL58A	6	LLM0_GPLL_T_FB_A/LDQ57	T	
L4	PL43B	6	LLM0_GPLL_C_FB_A	C	PL58B	6	LLM0_GPLL_C_FB_A/LDQ57	C	
VCCIO	VCCIO6	6			VCCIO6	6			
M1	PL44A	6	LLM0_GDLLT_IN_A	T (LVDS)*	PL59A	6	LLM0_GDLLT_IN_A**/LDQ57	T (LVDS)*	
N1	PL44B	6	LLM0_GDLL_C_IN_A	C (LVDS)*	PL59B	6	LLM0_GDLL_C_IN_A**/LDQ57	C (LVDS)*	
N2	PL45A	6	LLM0_GDLLT_FB_A	T	PL60A	6	LLM0_GDLLT_FB_A/LDQ57	T	
N3	PL45B	6	LLM0_GDLL_C_FB_A	C	PL60B	6	LLM0_GDLL_C_FB_A/LDQ57	C	
GNDIO	GNDIO6	-			GNDIO6	-			
M4	LLM0_PLLCAP	6			LLM0_PLLCAP	6			
VCCIO	VCCIO6	6			VCCIO6	6			
GNDIO	GNDIO6	-			GNDIO6	-			
K6	TCK	-			TCK	-			
L5	TDI	-			TDI	-			
N4	TMS	-			TMS	-			
N6	TDO	-			TDO	-			
K7	VCCJ	-			VCCJ	-			
M5	PB2A	5	BDQ6	T	PB2A	5	BDQ6	T	
N5	PB2B	5	BDQ6	C	PB2B	5	BDQ6	C	
L6	PB3A	5	BDQ6	T	PB3A	5	BDQ6	T	
M6	PB3B	5	BDQ6	C	PB3B	5	BDQ6	C	
P3	PB4A	5	BDQ6	T	PB4A	5	BDQ6	T	
VCCIO	VCCIO5	5			VCCIO5	5			
P4	PB4B	5	BDQ6	C	PB4B	5	BDQ6	C	
P2	PB5A	5	BDQ6	T	PB5A	5	BDQ6	T	
P1	PB5B	5	BDQ6	C	PB5B	5	BDQ6	C	
R1	PB6A	5	BDQS6	T	PB6A	5	BDQS6	T	
GNDIO	GNDIO5	-			GNDIO5	-			
R2	PB6B	5	BDQ6	C	PB6B	5	BDQ6	C	
R3	PB7A	5	BDQ6	T	PB7A	5	BDQ6	T	
T2	PB7B	5	BDQ6	C	PB7B	5	BDQ6	C	
R4	PB8A	5	BDQ6	T	PB8A	5	BDQ6	T	
VCCIO	VCCIO5	5			VCCIO5	5			
T3	PB8B	5	BDQ6	C	PB8B	5	BDQ6	C	
T4	PB10A	5	BDQ6	T	PB10A	5	BDQ6	T	
GNDIO	GNDIO5	-			GNDIO5	-			
T5	PB10B	5	BDQ6	C	PB10B	5	BDQ6	C	
VCCIO	VCCIO5	5			VCCIO5	5			
GNDIO	GNDIO5	-			GNDIO5	-			
T6	PB16A	5	VREF2_5/BDQ15	T	PB34A	5	VREF2_5/BDQ33	T	
R6	PB16B	5	VREF1_5/BDQ15	C	PB34B	5	VREF1_5/BDQ33	C	
P6	PB17A	5	PCLKT5_0/BDQ15	T	PB35A	5	PCLKT5_0/BDQ33	T	
P7	PB17B	5	PCLKC5_0/BDQ15	C	PB35B	5	PCLKC5_0/BDQ33	C	
VCCIO	VCCIO5	5			VCCIO5	5			
GNDIO	GNDIO5	-			GNDIO5	-			
T7	PB22A	4	PCLKT4_0/BDQ24	T	PB40A	4	PCLKT4_0/BDQ42	T	
VCCIO	VCCIO4	4			VCCIO4	4			
T8	PB22B	4	PCLKC4_0/BDQ24	C	PB40B	4	PCLKC4_0/BDQ42	C	

LFE2M-20E/SE and LFE2M-35E/SE Logic Signal Connections: 256 fpBGA

LFE2M20E/SE					LFE2M35E/SE				
Ball Number	Ball/Pad Function	Bank	Dual Function	Differential	Ball/Pad Function	Bank	Dual Function	Differential	
L7	PB23A	4	VREF2_4/BDQ24	T	PB41A	4	VREF2_4/BDQ42	T	
L8	PB23B	4	VREF1_4/BDQ24	C	PB41B	4	VREF1_4/BDQ42	C	
GNDIO	GNDIO4	-			GNDIO4	-			
VCCIO	VCCIO4	4			VCCIO4	4			
GNDIO	GNDIO4	-			GNDIO4	-			
P8	PB29A	4	BDQ33	T	PB47A	4	BDQ51	T	
N8	PB29B	4	BDQ33	C	PB47B	4	BDQ51	C	
R7	PB30A	4	BDQ33	T	PB48A	4	BDQ51	T	
R8	PB30B	4	BDQ33	C	PB48B	4	BDQ51	C	
N7	PB31A	4	BDQ33	T	PB49A	4	BDQ51	T	
M8	PB31B	4	BDQ33	C	PB49B	4	BDQ51	C	
VCCIO	VCCIO4	4			VCCIO4	4			
R9	PB32A	4	BDQ33	T	PB50A	4	BDQ51	T	
T9	PB32B	4	BDQ33	C	PB50B	4	BDQ51	C	
GNDIO	GNDIO4	-			GNDIO4	-			
T10	PB33A	4	BDQS33	T	PB51A	4	BDQS51	T	
R10	PB33B	4	BDQ33	C	PB51B	4	BDQ51	C	
N9	PB34A	4	BDQ33	T	PB52A	4	BDQ51	T	
P10	PB34B	4	BDQ33	C	PB52B	4	BDQ51	C	
VCCIO	VCCIO4	4			VCCIO4	4			
GNDIO	GNDIO4	-			GNDIO4	-			
L9	PB47A	4	BDQ51	T	PB65A	4	BDQ69	T	
M9	PB47B	4	BDQ51	C	PB65B	4	BDQ69	C	
T11	PB49A	4	BDQ51	T	PB67A	4	BDQ69	T	
R11	PB49B	4	BDQ51	C	PB67B	4	BDQ69	C	
VCCIO	VCCIO4	4			VCCIO4	4			
T12	PB50A	4	BDQ51	T	PB68A	4	BDQ69	T	
T13	PB50B	4	BDQ51	C	PB68B	4	BDQ69	C	
GNDIO	GNDIO4	-			GNDIO4	-			
P11	PB51A	4	BDQS51	T	PB69A	4	BDQS69	T	
N10	PB51B	4	BDQ51	C	PB69B	4	BDQ69	C	
T14	PB52A	4	BDQ51	T	PB70A	4	BDQ69	T	
R13	PB52B	4	BDQ51	C	PB70B	4	BDQ69	C	
R15	PB53A	4	BDQ51	T	PB71A	4	BDQ69	T	
R16	PB53B	4	BDQ51	C	PB71B	4	BDQ69	C	
VCCIO	VCCIO4	4			VCCIO4	4			
R14	PB54A	4	BDQ51	T	PB72A	4	BDQ69	T	
P15	PB54B	4	BDQ51	C	PB72B	4	BDQ69	C	
P16	PB55A	4	BDQ51	T	PB73A	4	BDQ69	T	
P14	PB55B	4	BDQ51	C	PB73B	4	BDQ69	C	
GNDIO	GNDIO4	-			GNDIO4	-			
L11	CFG2	8			CFG2	8			
L10	CFG1	8			CFG1	8			
P13	CFG0	8			CFG0	8			
N12	PROGRAMN	8			PROGRAMN	8			
N11	CCLK	8			CCLK	8			
M11	INITN	8			INITN	8			
N13	DONE	8			DONE	8			
GNDIO	GNDIO8	-			GNDIO8	-			

LFE2M-20E/SE and LFE2M-35E/SE Logic Signal Connections: 256 fpBGA

LFE2M20E/SE					LFE2M35E/SE				
Ball Number	Ball/Pad Function	Bank	Dual Function	Differential	Ball/Pad Function	Bank	Dual Function	Differential	
M12	PR53B	8	WRITEN	C	PR68B	8	WRITEN	C	
M13	PR53A	8	CS1N	T	PR68A	8	CS1N	T	
N14	PR52B	8	CSN	C	PR67B	8	CSN	C	
N15	PR52A	8	D0/SPIFASTN	T	PR67A	8	D0/SPIFASTN	T	
VCCIO	VCCIO8	8			VCCIO8	8			
N16	PR51B	8	D1	C	PR66B	8	D1	C	
M16	PR51A	8	D2	T	PR66A	8	D2	T	
L12	PR50B	8	D3	C	PR65B	8	D3	C	
GNDIO	GNDIO8	-			GNDIO8	-			
L13	PR50A	8	D4	T	PR65A	8	D4	T	
L16	PR49B	8	D5	C	PR64B	8	D5	C	
K16	PR49A	8	D6	T	PR64A	8	D6	T	
L14	PR48B	8	D7	C	PR63B	8	D7	C	
VCCIO	VCCIO8	8			VCCIO8	8			
L15	PR48A	8	DI/CSSPI0N	T	PR63A	8	DI/CSSPI0N	T	
K13	PR47B	8	DOU/CSON/CSSPI1N	C	PR62B	8	DOU/CSON/CSSPI1N	C	
K14	PR47A	8	BUSY/SISPI	T	PR62A	8	BUSY/SISPI	T	
K11	RLM0_PLLCAP	3			RLM0_PLLCAP	3			
K15	PR45B	3	RLM0_GDLLC_FB_A	C	PR60B	3	RLM0_GDLLC_FB_A/RDQ57	C	
GNDIO	GNDIO3	-			GNDIO3	-			
J16	PR45A	3	RLM0_GDLLT_FB_A	T	PR60A	3	RLM0_GDLLT_FB_A/RDQ57	T	
H16	PR44B	3	RLM0_GDLLC_IN_A	C (LVDS)*	PR59B	3	RLM0_GDLLC_IN_A**/RDQ57	C (LVDS)*	
J15	PR44A	3	RLM0_GDLLT_IN_A	T (LVDS)*	PR59A	3	RLM0_GDLLT_IN_A**/RDQ57	T (LVDS)*	
J14	PR43B	3	RLM0_GPLLC_IN_A	C	PR58B	3	RLM0_GPLLC_IN_A**/RDQ57	C	
VCCIO	VCCIO3	3			VCCIO3	3			
J13	PR43A	3	RLM0_GPLLT_IN_A	T	PR58A	3	RLM0_GPLLT_IN_A**/RDQ57	T	
H13	PR42B	3	RLM0_GPLLC_FB_A	C (LVDS)*	PR57B	3	RLM0_GPLLC_FB_A/RDQ57	C (LVDS)*	
H12	PR42A	3	RLM0_GPLLT_FB_A	T (LVDS)*	PR57A	3	RLM0_GPLLT_FB_A/RDQ57***	T (LVDS)*	
GNDIO	GNDIO3	-			GNDIO3	-			
VCCIO	VCCIO3	3			VCCIO3	3			
G16	PR32B	3	RLM1_SPLLC_FB_A	C	PR42B	3	RLM2_SPLLC_FB_A	C	
VCCIO	VCCIO3	3			VCCIO3	3			
H15	PR32A	3	RLM1_SPLLT_FB_A	T	PR42A	3	RLM2_SPLLT_FB_A	T	
E16	PR31B	3	RLM1_SPLLC_IN_A	C (LVDS)*	PR41B	3	RLM2_SPLLC_IN_A	C (LVDS)*	
F15	PR31A	3	RLM1_SPLLT_IN_A	T (LVDS)*	PR41A	3	RLM2_SPLLT_IN_A	T (LVDS)*	
GNDIO	GNDIO3	-			GNDIO3	-			
VCCIO	VCCIO3	3			VCCIO3	3			
F16	PR28B	3	VREF2_3	C	PR38B	3	VREF2_3	C	
G15	PR28A	3	VREF1_3	T	PR38A	3	VREF1_3	T	
J11	PR27B	3	PCLKC3_0	C (LVDS)*	PR37B	3	PCLKC3_0	C (LVDS)*	
J12	PR27A	3	PCLKT3_0	T (LVDS)*	PR37A	3	PCLKT3_0	T (LVDS)*	
G14	PR25B	2	PCLKC2_0/RDQ22	C	PR35B	2	PCLKC2_0/RDQ32	C	
G13	PR25A	2	PCLKT2_0/RDQ22	T	PR35A	2	PCLKT2_0/RDQ32	T	
GNDIO	GNDIO2	-			GNDIO2	-			
F14	PR24B	2	RDQ22	C (LVDS)*	PR34B	2	RDQ32	C (LVDS)*	
F13	PR24A	2	RDQ22	T (LVDS)*	PR34A	2	RDQ32	T (LVDS)*	
VCCIO	VCCIO2	2			VCCIO2	2			
GNDIO	GNDIO2	-			GNDIO2	-			
H11	PR14B	2		C	PR14B	2	RDQ15	C	

LFE2M-20E/SE and LFE2M-35E/SE Logic Signal Connections: 256 fpBGA

LFE2M20E/SE					LFE2M35E/SE				
Ball Number	Ball/Pad Function	Bank	Dual Function	Differential	Ball/Pad Function	Bank	Dual Function	Differential	
G11	PR14A	2		T	PR14A	2	RDQ15	T	
E13	PR13B	2		C (LVDS)*	PR13B	2	RDQ15	C(LVDS)*	
F12	PR13A	2		T (LVDS)*	PR13A	2	RDQ15	T (LVDS)*	
VCCIO	VCCIO2	2			VCCIO2	2			
F11	PR12B	2	RUM0_SPLLC_FB_A	C	PR12B	2	RUM0_SPLLC_FB_A/RDQ15	C	
E12	PR12A	2	RUM0_SPLLT_FB_A	T	PR12A	2	RUM0_SPLLT_FB_A/RDQ15	T	
D16	PR11B	2	RUM0_SPLLC_IN_A	C (LVDS)*	PR11B	2	RUM0_SPLLC_IN_A/RDQ15	C(LVDS)*	
D15	PR11A	2	RUM0_SPLLT_IN_A	T (LVDS)*	PR11A	2	RUM0_SPLLT_IN_A/RDQ15	T (LVDS)*	
C16	PR9B	2	VREF2_2	C	PR9B	2	VREF2_2	C	
GNDIO	GNDIO2	-			GNDIO2	-			
B16	PR9A	2	VREF1_2	T	PR9A	2	VREF1_2	T	
VCCIO	VCCIO2	2			VCCIO2	2			
F4	XRES	-			XRES	-			
C15	URC_SQ_VCCR_X0	12			URC_SQ_VCCR_X0	12			
A14	URC_SQ_HDIN_P0	12		T	URC_SQ_HDIN_P0	12		T	
B15	URC_SQ_VCCIB0	12			URC_SQ_VCCIB0	12			
B14	URC_SQ_HDINN0	12		C	URC_SQ_HDINN0	12		C	
C12	URC_SQ_VCCTX0	12			URC_SQ_VCCTX0	12			
A11	URC_SQ_HDOUT_P0	12		T	URC_SQ_HDOUT_P0	12		T	
A12	URC_SQ_VCCOB0	12			URC_SQ_VCCOB0	12			
B11	URC_SQ_HDOUT_N0	12		C	URC_SQ_HDOUT_N0	12		C	
C11	URC_SQ_VCCTX1	12			URC_SQ_VCCTX1	12			
B10	URC_SQ_HDOUT_N1	12		C	URC_SQ_HDOUT_N1	12		C	
C10	URC_SQ_VCCOB1	12			URC_SQ_VCCOB1	12			
A10	URC_SQ_HDOUT_P1	12		T	URC_SQ_HDOUT_P1	12		T	
C14	URC_SQ_VCCR_X1	12			URC_SQ_VCCR_X1	12			
B13	URC_SQ_HDINN1	12		C	URC_SQ_HDINN1	12		C	
C13	URC_SQ_VCCIB1	12			URC_SQ_VCCIB1	12			
A13	URC_SQ_HDIN_P1	12		T	URC_SQ_HDIN_P1	12		T	
B9	URC_SQ_VCCAUX33	12			URC_SQ_VCCAUX33	12			
D8	URC_SQ_REFCLKN	12		C	URC_SQ_REFCLKN	12		C	
D9	URC_SQ_REFCLKP	12		T	URC_SQ_REFCLKP	12		T	
C9	URC_SQ_VCCP	12			URC_SQ_VCCP	12			
A5	URC_SQ_HDIN_P2	12		T	URC_SQ_HDIN_P2	12		T	
C5	URC_SQ_VCCIB2	12			URC_SQ_VCCIB2	12			
B5	URC_SQ_HDINN2	12		C	URC_SQ_HDINN2	12		C	
C4	URC_SQ_VCCR_X2	12			URC_SQ_VCCR_X2	12			
A8	URC_SQ_HDOUT_P2	12		T	URC_SQ_HDOUT_P2	12		T	
C8	URC_SQ_VCCOB2	12			URC_SQ_VCCOB2	12			
B8	URC_SQ_HDOUT_N2	12		C	URC_SQ_HDOUT_N2	12		C	
C7	URC_SQ_VCCTX2	12			URC_SQ_VCCTX2	12			
B7	URC_SQ_HDOUT_N3	12		C	URC_SQ_HDOUT_N3	12		C	
A6	URC_SQ_VCCOB3	12			URC_SQ_VCCOB3	12			
A7	URC_SQ_HDOUT_P3	12		T	URC_SQ_HDOUT_P3	12		T	
C6	URC_SQ_VCCTX3	12			URC_SQ_VCCTX3	12			
B4	URC_SQ_HDINN3	12		C	URC_SQ_HDINN3	12		C	
B3	URC_SQ_VCCIB3	12			URC_SQ_VCCIB3	12			
A4	URC_SQ_HDIN_P3	12		T	URC_SQ_HDIN_P3	12		T	
C3	URC_SQ_VCCR_X3	12			URC_SQ_VCCR_X3	12			

LFE2M-20E/SE and LFE2M-35E/SE Logic Signal Connections: 256 fpBGA

LFE2M20E/SE					LFE2M35E/SE				
Ball Number	Ball/Pad Function	Bank	Dual Function	Differential	Ball/Pad Function	Bank	Dual Function	Differential	
GNDIO	GNDIO1	-			GNDIO1	-			
VCCIO	VCCIO1	1			VCCIO1	1			
GNDIO	GNDIO0	-			GNDIO0	-			
VCCIO	VCCIO0	0			VCCIO0	0			
G10	VCCPLL	-			VCCPLL	-			
G7	VCC	-			VCC	-			
G9	VCC	-			VCC	-			
H7	VCC	-			VCC	-			
J10	VCC	-			VCC	-			
K10	VCC	-			VCC	-			
K8	VCC	-			VCC	-			
E7	VCCIO0	0			VCCIO0	0			
VCCIO	VCCIO0	0			VCCIO0	0			
E10	VCCIO1	1			VCCIO1	1			
VCCIO	VCCIO1	1			VCCIO1	1			
E14	VCCIO2	2			VCCIO2	2			
G12	VCCIO2	2			VCCIO2	2			
VCCIO	VCCIO2	2			VCCIO2	2			
K12	VCCIO3	3			VCCIO3	3			
M14	VCCIO3	3			VCCIO3	3			
VCCIO	VCCIO3	3			VCCIO3	3			
M10	VCCIO4	4			VCCIO4	4			
P12	VCCIO4	4			VCCIO4	4			
VCCIO	VCCIO4	4			VCCIO4	4			
M7	VCCIO5	5			VCCIO5	5			
P5	VCCIO5	5			VCCIO5	5			
VCCIO	VCCIO5	5			VCCIO5	5			
K5	VCCIO6	6			VCCIO6	6			
M3	VCCIO6	6			VCCIO6	6			
VCCIO	VCCIO6	6			VCCIO6	6			
E3	VCCIO7	7			VCCIO7	7			
G5	VCCIO7	7			VCCIO7	7			
VCCIO	VCCIO7	7			VCCIO7	7			
T15	VCCIO8	8			VCCIO8	8			
VCCIO	VCCIO8	8			VCCIO8	8			
G8	VCCAUX	-			VCCAUX	-			
H10	VCCAUX	-			VCCAUX	-			
J7	VCCAUX	-			VCCAUX	-			
K9	VCCAUX	-			VCCAUX	-			
A1	GND	-			GND	-			
A15	GND	-			GND	-			
A16	GND	-			GND	-			
A3	GND	-			GND	-			
A9	GND	-			GND	-			
B12	GND	-			GND	-			
B6	GND	-			GND	-			
E15	GND	-			GND	-			
E2	GND	-			GND	-			
H14	GND	-			GND	-			

LFE2M-20E/SE and LFE2M-35E/SE Logic Signal Connections: 256 fpBGA

LFE2M20E/SE					LFE2M35E/SE				
Ball Number	Ball/Pad Function	Bank	Dual Function	Differential	Ball/Pad Function	Bank	Dual Function	Differential	
H8	GND	-			GND	-			
H9	GND	-			GND	-			
J3	GND	-			GND	-			
J8	GND	-			GND	-			
J9	GND	-			GND	-			
M15	GND	-			GND	-			
M2	GND	-			GND	-			
P9	GND	-			GND	-			
R12	GND	-			GND	-			
R5	GND	-			GND	-			
T1	GND	-			GND	-			
T16	GND	-			GND	-			
D10	NC	-			NC	-			
D11	NC	-			NC	-			
D12	NC	-			NC	-			
D13	NC	-			NC	-			
D14	NC	-			NC	-			
D4	NC	-			NC	-			
D5	NC	-			NC	-			
D6	NC	-			NC	-			
D7	NC	-			NC	-			
E11	NC	-			NC	-			
E6	NC	-			NC	-			
E8	NC	-			NC	-			
E9	NC	-			NC	-			
F10	NC	-			NC	-			
F7	NC	-			NC	-			
F8	NC	-			NC	-			
F9	NC	-			NC	-			

* Supports true LVDS. Other differential signals must be emulated with external resistors.

** These dedicated input pins can be used for GPLLs or GDLLs within the respective quadrant.

***Due to packaging bond out option, this DQS does not have all the necessary DQ pins bonded out for a full 8-bit data width.

Note: VCCIO and GND pads are used to determine the average DC current drawn by I/Os between GND/VCCIO connections, or between the last GND/VCCIO in an I/O bank and the end of an I/O bank. The substrate pads listed in the Pin Table do not necessarily have a one to one connection with a package ball or pin.

LFE2M20E/SE and LFE2M35E/SE Logic Signal Connections: 484 fpBGA

LFE2M20E/SE					LFE2M35E/SE				
Ball Number	Ball/Pad Function	Bank	Dual Function	Differential	Ball/Pad Function	Bank	Dual Function	Differential	
D1	PL2A	7	LDQ6	T (LVDS)*	PL2A	7	LDQ6	T (LVDS)*	
E1	PL2B	7	LDQ6	C (LVDS)*	PL2B	7	LDQ6	C (LVDS)*	
F1	PL3A	7	LDQ6	T	PL3A	7	LDQ6	T	
F2	PL3B	7	LDQ6	C	PL3B	7	LDQ6	C	
F5	PL4A	7	LDQ6	T (LVDS)*	PL4A	7	LDQ6	T (LVDS)*	
VCCIO	VCCIO7	7			VCCIO7	7			
G6	PL4B	7	LDQ6	C (LVDS)*	PL4B	7	LDQ6	C (LVDS)*	
F4	PL5A	7	LDQ6	T	PL5A	7	LDQ6	T	
F3	PL5B	7	LDQ6	C	PL5B	7	LDQ6	C	
G1	PL6A	7	LDQS6	T (LVDS)*	PL6A	7	LDQS6	T (LVDS)*	
GNDIO	GNDIO7	-			GNDIO7	-			
G2	PL6B	7	LDQ6	C (LVDS)*	PL6B	7	LDQ6	C (LVDS)*	
H1	PL7A	7	LDQ6	T	PL7A	7	LDQ6	T	
H2	PL7B	7	LDQ6	C	PL7B	7	LDQ6	C	
VCCIO	VCCIO7	7			VCCIO7	7			
H7	PL8A	7	LDQ6	T (LVDS)*	PL8A	7	LDQ6	T (LVDS)*	
H6	PL8B	7	LDQ6	C (LVDS)*	PL8B	7	LDQ6	C (LVDS)*	
G3	PL9A	7	VREF2_7/LDQ6	T	PL9A	7	VREF2_7/LDQ6	T	
H3	PL9B	7	VREF1_7/LDQ6	C	PL9B	7	VREF1_7/LDQ6	C	
GNDIO	GNDIO7	-			GNDIO7	-			
H5	PL11A	7	LUM0_SPLLT_IN_A	T (LVDS)*	PL11A	7	LUM0_SPLLT_IN_A/LDQ15	T (LVDS)*	
H4	PL11B	7	LUM0_SPLLC_IN_A	C (LVDS)*	PL11B	7	LUM0_SPLLC_IN_A/LDQ15	C (LVDS)*	
J1	PL12A	7	LUM0_SPLLT_FB_A	T	PL12A	7	LUM0_SPLLT_FB_A/LDQ15	T	
J2	PL12B	7	LUM0_SPLLC_FB_A	C	PL12B	7	LUM0_SPLLC_FB_A/LDQ15	C	
J3	PL13A	7		T (LVDS)*	PL13A	7	LDQ15	T (LVDS)*	
VCCIO	VCCIO7	7			VCCIO7	7			
J4	PL13B	7		C (LVDS)*	PL13B	7	LDQ15	C (LVDS)*	
J7	PL14A	7		T	PL14A	7	LDQ15	T	
J6	PL14B	7		C	PL14B	7	LDQ15	C	
GNDIO	GNDIO7	-			GNDIO7	-			
VCCIO	VCCIO7	7			VCCIO7	7			
K1	PL18A	7	LUM1_SPLLT_IN_A/LDQ22	T (LVDS)*	PL28A	7	LUM1_SPLLT_IN_A/LDQ32	T (LVDS)*	
K2	PL18B	7	LUM1_SPLLC_IN_A/LDQ22	C (LVDS)*	PL28B	7	LUM1_SPLLC_IN_A/LDQ32	C (LVDS)*	
J5	PL19A	7	LUM1_SPLLT_FB_A/LDQ22	T	PL29A	7	LUM1_SPLLT_FB_A/LDQ32	T	
K5	PL19B	7	LUM1_SPLLC_FB_A/LDQ22	C	PL29B	7	LUM1_SPLLC_FB_A/LDQ32	C	
VCCIO	VCCIO7	7			VCCIO7	7			
K7	PL20A	7	LDQ22	T (LVDS)*	PL30A	7	LDQ32	T (LVDS)*	
K6	PL20B	7	LDQ22	C (LVDS)*	PL30B	7	LDQ32	C (LVDS)*	
L6	PL21A	7	LDQ22	T	PL31A	7	LDQ32	T	
L7	PL21B	7	LDQ22	C	PL31B	7	LDQ32	C	
GNDIO	GNDIO7	-			GNDIO7	-			
L1	PL22A	7	LDQS22	T (LVDS)*	PL32A	7	LDQS32	T (LVDS)*	
L2	PL22B	7	LDQ22	C (LVDS)*	PL32B	7	LDQ32	C (LVDS)*	
M7	PL23A	7	LDQ22	T	PL33A	7	LDQ32	T	
VCCIO	VCCIO7	7			VCCIO7	7			
L5	PL23B	7	LDQ22	C	PL33B	7	LDQ32	C	
L3	PL24A	7	LDQ22	T (LVDS)*	PL34A	7	LDQ32	T (LVDS)*	
L4	PL24B	7	LDQ22	C (LVDS)*	PL34B	7	LDQ32	C (LVDS)*	
M1	PL25A	7	PCLKT7_0/LDQ22	T	PL35A	7	PCLKT7_0/LDQ32	T	

LFE2M20E/SE and LFE2M35E/SE Logic Signal Connections: 484 fpBGA

LFE2M20E/SE					LFE2M35E/SE				
Ball Number	Ball/Pad Function	Bank	Dual Function	Differential	Ball/Pad Function	Bank	Dual Function	Differential	
GNDIO	GNDIO7	-			GNDIO7	-			
M2	PL25B	7	PCLKC7_0/LDQ22	C	PL35B	7	PCLKC7_0/LDQ32	C	
M6	PL27A	6	PCLKT6_0	T (LVDS)*	PL37A	6	PCLKT6_0	T (LVDS)*	
M5	PL27B	6	PCLKC6_0	C (LVDS)*	PL37B	6	PCLKC6_0	C (LVDS)*	
M3	PL28A	6	VREF2_6	T	PL38A	6	VREF2_6	T	
M4	PL28B	6	VREF1_6	C	PL38B	6	VREF1_6	C	
VCCIO	VCCIO6	6			VCCIO6	6			
N7	PL31A	6	LLM1_SPLLT_IN_A	T (LVDS)*	PL41A	6	LLM2_SPLLT_IN_A	T (LVDS)*	
GNDIO	GNDIO6	-			GNDIO6	-			
N6	PL31B	6	LLM1_SPLLC_IN_A	C (LVDS)*	PL41B	6	LLM2_SPLLC_IN_A	C (LVDS)*	
N1	PL32A	6	LLM1_SPLLT_FB_A	T	PL42A	6	LLM2_SPLLT_FB_A	T	
N2	PL32B	6	LLM1_SPLLC_FB_A	C	PL42B	6	LLM2_SPLLC_FB_A	C	
VCCIO	VCCIO6	6			VCCIO6	6			
GNDIO	GNDIO6	-			GNDIO6	-			
P6	PL38A	6	LDQS38****	T (LVDS)*	PL48A	6	LDQS48****	T (LVDS)*	
N5	PL38B	6	LDQ38	C (LVDS)*	PL48B	6	LDQ48	C (LVDS)*	
P1	PL39A	6	LDQ38	T	PL49A	6	LDQ48	T	
VCCIO	VCCIO6	6			VCCIO6	6			
P2	PL39B	6	LDQ38	C	PL49B	6	LDQ48	C	
P3	PL40A	6	LDQ38	T (LVDS)*	PL50A	6	LDQ48	T (LVDS)*	
P4	PL40B	6	LDQ38	C (LVDS)*	PL50B	6	LDQ48	C (LVDS)*	
P5	PL41A	6	LDQ38	T	PL51A	6	LDQ48	T	
GNDIO	GNDIO6	-			GNDIO6	-			
P7	PL41B	6	LDQ38	C	PL51B	6	LDQ48	C	
R1	PL42A	6	LLM0_GPLLT_IN_A**	T (LVDS)*	PL57A	6	LLM0_GPLLT_IN_A**/LDQS57****	T (LVDS)*	
GNDIO	GNDIO6	-			GNDIO6	-			
R2	PL42B	6	LLM0_GPLLC_IN_A**	C (LVDS)*	PL57B	6	LLM0_GPLLC_IN_A**/LDQ57	C (LVDS)*	
R3	PL43A	6	LLM0_GPLLT_FB_A	T	PL58A	6	LLM0_GPLLT_FB_A/LDQ57	T	
R4	PL43B	6	LLM0_GPLLC_FB_A	C	PL58B	6	LLM0_GPLLC_FB_A/LDQ57	C	
VCCIO	VCCIO6	6			VCCIO6	6			
R6	PL44A	6	LLM0_GDLLT_IN_A**	T (LVDS)*	PL59A	6	LLM0_GDLLT_IN_A**/LDQ57	T (LVDS)*	
R5	PL44B	6	LLM0_GDLLC_IN_A**	C (LVDS)*	PL59B	6	LLM0_GDLLC_IN_A**/LDQ57	C (LVDS)*	
T1	PL45A	6	LLM0_GDLLT_FB_A	T	PL60A	6	LLM0_GDLLT_FB_A/LDQ57	T	
T2	PL45B	6	LLM0_GDLLC_FB_A	C	PL60B	6	LLM0_GDLLC_FB_A/LDQ57	C	
GNDIO	GNDIO6	-			GNDIO6	-			
R7	LLM0_PLLCAP	6			LLM0_PLLCAP	6			
T6	PL47A	6	LDQ51	T (LVDS)*	PL62A	6	LDQ66	T (LVDS)*	
T7	PL47B	6	LDQ51	C (LVDS)*	PL62B	6	LDQ66	C (LVDS)*	
U1	PL48A	6	LDQ51	T	PL63A	6	LDQ66	T	
U2	PL48B	6	LDQ51	C	PL63B	6	LDQ66	C	
VCCIO	VCCIO6	6			VCCIO6	6			
T3	PL49A	6	LDQ51	T (LVDS)*	PL64A	6	LDQ66	T (LVDS)*	
U3	PL49B	6	LDQ51	C (LVDS)*	PL64B	6	LDQ66	C (LVDS)*	
U6	PL50A	6	LDQ51	T	NC	-			
U5	PL50B	6	LDQ51	C	PL65B	6	LDQ66	C	
GNDIO	GNDIO6	-			GNDIO6	-			
V5	PL51A	6	LDQS51	T (LVDS)*	PL66A	6	LDQS66	T (LVDS)*	
U4	PL51B	6	LDQ51	C (LVDS)*	PL66B	6	LDQ66	C (LVDS)*	
V1	PL52A	6	LDQ51	T	PL67A	6	LDQ66	T	

LFE2M20E/SE and LFE2M35E/SE Logic Signal Connections: 484 fpBGA

LFE2M20E/SE					LFE2M35E/SE				
Ball Number	Ball/Pad Function	Bank	Dual Function	Differential	Ball/Pad Function	Bank	Dual Function	Differential	
VCCIO	VCCIO6	6			VCCIO6	6			
V3	PL52B	6	LDQ51	C	PL67B	6	LDQ66	C	
W1	PL53A	6	LDQ51	T (LVDS)*	PL68A	6	LDQ66	T (LVDS)*	
Y1	PL53B	6	LDQ51	C (LVDS)*	PL68B	6	LDQ66	C (LVDS)*	
AA1	PL54A	6	LDQ51	T	PL69A	6	LDQ66	T	
GNDIO	GNDIO6	-			GNDIO6	-			
AA2	PL54B	6	LDQ51	C	PL69B	6	LDQ66	C	
V4	TCK	-			TCK	-			
Y2	TDI	-			TDI	-			
Y3	TMS	-			TMS	-			
W3	TDO	-			TDO	-			
W4	VCCJ	-			VCCJ	-			
W5	PB2A	5	BDQ6	T	PB2A	5	BDQ6	T	
Y4	PB2B	5	BDQ6	C	PB2B	5	BDQ6	C	
W6	PB3A	5	BDQ6	T	PB3A	5	BDQ6	T	
V6	PB3B	5	BDQ6	C	PB3B	5	BDQ6	C	
AA3	PB4A	5	BDQ6	T	PB4A	5	BDQ6	T	
VCCIO	VCCIO5	5			VCCIO5	5			
AB2	PB4B	5	BDQ6	C	PB4B	5	BDQ6	C	
T8	PB5A	5	BDQ6	T	PB5A	5	BDQ6	T	
U7	PB5B	5	BDQ6	C	PB5B	5	BDQ6	C	
U8	PB6A	5	BDQS6	T	PB6A	5	BDQS6	T	
GNDIO	GNDIO5	-			GNDIO5	-			
T9	PB6B	5	BDQ6	C	PB6B	5	BDQ6	C	
V8	PB7A	5	BDQ6	T	PB7A	5	BDQ6	T	
W8	PB7B	5	BDQ6	C	PB7B	5	BDQ6	C	
Y6	PB8A	5	BDQ6	T	PB8A	5	BDQ6	T	
VCCIO	VCCIO5	5			VCCIO5	5			
Y5	PB8B	5	BDQ6	C	PB8B	5	BDQ6	C	
AB3	PB9A	5	BDQ6	T	PB9A	5	BDQ6	T	
AB4	PB9B	5	BDQ6	C	PB9B	5	BDQ6	C	
AB5	PB10A	5	BDQ6	T	PB10A	5	BDQ6	T	
GNDIO	GNDIO5	-			GNDIO5	-			
AA6	PB10B	5	BDQ6	C	PB10B	5	BDQ6	C	
V9	PB13A	5	BDQ15	T	PB31A	5	BDQ33	T	
U9	PB13B	5	BDQ15	C	PB31B	5	BDQ33	C	
VCCIO	VCCIO5	5			VCCIO5	5			
-	-	-			GNDIO5	-			
U10	PB14A	5	BDQ15	T	PB32A	5	BDQ33	T	
T10	PB14B	5	BDQ15	C	PB32B	5	BDQ33	C	
GNDIO	GNDIO5	-			GNDIO5	-			
W9	PB15A	5	BDQS15****	T	PB33A	5	BDQS33****	T	
Y8	PB15B	5	BDQ15	C	PB33B	5	BDQ33	C	
AA7	PB16A	5	VREF2_5/BDQ15	T	PB34A	5	VREF2_5/BDQ33	T	
Y7	PB16B	5	VREF1_5/BDQ15	C	PB34B	5	VREF1_5/BDQ33	C	
AB6	PB17A	5	PCLKT5_0/BDQ15	T	PB35A	5	PCLKT5_0/BDQ33	T	
AB7	PB17B	5	PCLKC5_0/BDQ15	C	PB35B	5	PCLKC5_0/BDQ33	C	
VCCIO	VCCIO5	5			VCCIO5	5			
GNDIO	GNDIO5	-			GNDIO5	-			

LFE2M20E/SE and LFE2M35E/SE Logic Signal Connections: 484 fpBGA

LFE2M20E/SE					LFE2M35E/SE				
Ball Number	Ball/Pad Function	Bank	Dual Function	Differential	Ball/Pad Function	Bank	Dual Function	Differential	
AA8	PB22A	4	PCLKT4_0/BDQ24	T	PB40A	4	PCLKT4_0/BDQ42	T	
VCCIO	VCCIO4	4			VCCIO4	4			
AB8	PB22B	4	PCLKC4_0/BDQ24	C	PB40B	4	PCLKC4_0/BDQ42	C	
AA9	PB23A	4	VREF2_4/BDQ24	T	PB41A	4	VREF2_4/BDQ42	T	
Y9	PB23B	4	VREF1_4/BDQ24	C	PB41B	4	VREF1_4/BDQ42	C	
AB9	PB24A	4	BDQS24****	T	PB42A	4	BDQS42****	T	
GNDIO	GNDIO4	-			GNDIO4	-			
AB10	PB24B	4	BDQ24	C	PB42B	4	BDQ42	C	
AA10	PB25A	4	BDQ24	T	PB43A	4	BDQ42	T	
Y11	PB25B	4	BDQ24	C	PB43B	4	BDQ42	C	
VCCIO	VCCIO4	4			VCCIO4	4			
GNDIO	GNDIO4	-			GNDIO4	-			
V10	PB29A	4	BDQ33	T	PB47A	4	BDQ51	T	
U11	PB29B	4	BDQ33	C	PB47B	4	BDQ51	C	
V11	PB30A	4	BDQ33	T	PB48A	4	BDQ51	T	
W11	PB30B	4	BDQ33	C	PB48B	4	BDQ51	C	
AA11	PB31A	4	BDQ33	T	PB49A	4	BDQ51	T	
AB11	PB31B	4	BDQ33	C	PB49B	4	BDQ51	C	
VCCIO	VCCIO4	4			VCCIO4	4			
T11	PB32A	4	BDQ33	T	PB50A	4	BDQ51	T	
U12	PB32B	4	BDQ33	C	PB50B	4	BDQ51	C	
GNDIO	GNDIO4	-			GNDIO4	-			
AA12	PB33A	4	BDQS33	T	PB51A	4	BDQS51	T	
Y12	PB33B	4	BDQ33	C	PB51B	4	BDQ51	C	
V12	PB34A	4	BDQ33	T	PB52A	4	BDQ51	T	
W12	PB34B	4	BDQ33	C	PB52B	4	BDQ51	C	
AB12	PB35A	4	BDQ33	T	PB53A	4	BDQ51	T	
AA13	PB35B	4	BDQ33	C	PB53B	4	BDQ51	C	
VCCIO	VCCIO4	4			VCCIO4	4			
T12	PB36A	4	BDQ33	T	PB54A	4	BDQ51	T	
U13	PB36B	4	BDQ33	C	PB54B	4	BDQ51	C	
V13	PB37A	4	BDQ33	T	PB55A	4	BDQ51	T	
T13	PB37B	4	BDQ33	C	PB55B	4	BDQ51	C	
GNDIO	GNDIO4	-			GNDIO4	-			
AB13	PB38A	4	BDQ42	T	PB56A	4	BDQ60	T	
AB14	PB38B	4	BDQ42	C	PB56B	4	BDQ60	C	
U14	PB39A	4	BDQ42	T	PB57A	4	BDQ60	T	
T14	PB39B	4	BDQ42	C	PB57B	4	BDQ60	C	
AA14	PB40A	4	BDQ42	T	PB58A	4	BDQ60	T	
VCCIO	VCCIO4	4			VCCIO4	4			
Y14	PB40B	4	BDQ42	C	PB58B	4	BDQ60	C	
W14	PB41A	4	BDQ42	T	PB59A	4	BDQ60	T	
V14	PB41B	4	BDQ42	C	PB59B	4	BDQ60	C	
AB15	PB42A	4	BDQS42	T	PB60A	4	BDQS60	T	
GNDIO	GNDIO4	-			GNDIO4	-			
AA15	PB42B	4	BDQ42	C	PB60B	4	BDQ60	C	
V15	PB43A	4	BDQ42	T	PB61A	4	BDQ60	T	
U15	PB43B	4	BDQ42	C	PB61B	4	BDQ60	C	
AB16	PB44A	4	BDQ42	T	PB62A	4	BDQ60	T	

LFE2M20E/SE and LFE2M35E/SE Logic Signal Connections: 484 fpBGA

LFE2M20E/SE					LFE2M35E/SE			
Ball Number	Ball/Pad Function	Bank	Dual Function	Differential	Ball/Pad Function	Bank	Dual Function	Differential
VCCIO	VCCIO4	4			VCCIO4	4		
AA16	PB44B	4	BDQ42	C	PB62B	4	BDQ60	C
AB17	PB45A	4	BDQ42	T	PB63A	4	BDQ60	T
AA17	PB45B	4	BDQ42	C	PB63B	4	BDQ60	C
Y15	PB46A	4	BDQ42	T	PB64A	4	BDQ60	T
GNDIO	GNDIO4	-			GNDIO4	-		
W15	PB46B	4	BDQ42	C	PB64B	4	BDQ60	C
AB20	PB47A	4	BDQ51	T	PB65A	4	BDQ69	T
AB21	PB47B	4	BDQ51	C	PB65B	4	BDQ69	C
AA21	PB48A	4	BDQ51	T	PB66A	4	BDQ69	T
AA20	PB48B	4	BDQ51	C	PB66B	4	BDQ69	C
AB19	PB49A	4	BDQ51	T	PB67A	4	BDQ69	T
AB18	PB49B	4	BDQ51	C	PB67B	4	BDQ69	C
VCCIO	VCCIO4	4			VCCIO4	4		
Y22	PB50A	4	BDQ51	T	PB68A	4	BDQ69	T
Y21	PB50B	4	BDQ51	C	PB68B	4	BDQ69	C
GNDIO	GNDIO4	-			GNDIO4	-		
Y17	PB51A	4	BDQS51	T	PB69A	4	BDQS69	T
Y18	PB51B	4	BDQ51	C	PB69B	4	BDQ69	C
Y16	PB52A	4	BDQ51	T	PB70A	4	BDQ69	T
W17	PB52B	4	BDQ51	C	PB70B	4	BDQ69	C
Y19	PB53A	4	BDQ51	T	PB71A	4	BDQ69	T
Y20	PB53B	4	BDQ51	C	PB71B	4	BDQ69	C
VCCIO	VCCIO4	4			VCCIO4	4		
W19	PB54A	4	BDQ51	T	PB72A	4	BDQ69	T
W18	PB54B	4	BDQ51	C	PB72B	4	BDQ69	C
V17	PB55A	4	BDQ51	T	PB73A	4	BDQ69	T
V18	PB55B	4	BDQ51	C	PB73B	4	BDQ69	C
GNDIO	GNDIO4	-			GNDIO4	-		
W20	CFG2	8			CFG2	8		
V20	CFG1	8			CFG1	8		
V19	CFG0	8			CFG0	8		
V22	PROGRAMN	8			PROGRAMN	8		
W22	CCLK	8			CCLK	8		
U18	INITN	8			INITN	8		
U22	DONE	8			DONE	8		
GNDIO	GNDIO8	-			GNDIO8	-		
U20	PR53B	8	WRITEN***	C	PR68B	8	WRITEN***	C
U21	PR53A	8	CS1N***	T	PR68A	8	CS1N***	T
U17	PR52B	8	CSN***	C	PR67B	8	CSN***	C
U16	PR52A	8	D0/SPIFASTN***	T	PR67A	8	D0/SPIFASTN***	T
VCCIO	VCCIO8	8			VCCIO8	8		
T16	PR51B	8	D1***	C	PR66B	8	D1***	C
T17	PR51A	8	D2***	T	PR66A	8	D2***	T
T22	PR50B	8	D3***	C	PR65B	8	D3***	C
GNDIO	GNDIO8	-			GNDIO8	-		
R22	PR50A	8	D4***	T	PR65A	8	D4***	T
T15	PR49B	8	D5***	C	PR64B	8	D5***	C
R17	PR49A	8	D6***	T	PR64A	8	D6***	T

LFE2M20E/SE and LFE2M35E/SE Logic Signal Connections: 484 fpBGA

LFE2M20E/SE					LFE2M35E/SE			
Ball Number	Ball/Pad Function	Bank	Dual Function	Differential	Ball/Pad Function	Bank	Dual Function	Differential
T20	PR48B	8	D7***	C	PR63B	8	D7***	C
VCCIO	VCCIO8	8			VCCIO8	8		
T21	PR48A	8	DI/CSSPI0N***	T	PR63A	8	DI/CSSPI0N***	T
R21	PR47B	8	DOU/CSON/CSSPI1N***	C	PR62B	8	DOU/CSON/CSSPI1N***	C
R20	PR47A	8	BUSY/SISPI***	T	PR62A	8	BUSY/SISPI***	T
R16	RLM0_PLLCAP	3			RLM0_PLLCAP	3		
R18	PR45B	3	RLM0_GDLLC_FB_A	C	PR60B	3	RLM0_GDLLC_FB_A/RDQ57	C
GNDIO	GNDIO3	-			GNDIO3	-		
R19	PR45A	3	RLM0_GDLLT_FB_A	T	PR60A	3	RLM0_GDLLT_FB_A/RDQ57	T
P22	PR44B	3	RLM0_GDLLC_IN_A**	C (LVDS)*	PR59B	3	RLM0_GDLLC_IN_A**/RDQ57	C (LVDS)*
P21	PR44A	3	RLM0_GDLLT_IN_A**	T (LVDS)*	PR59A	3	RLM0_GDLLT_IN_A**/RDQ57	T (LVDS)*
P16	PR43B	3	RLM0_GPLLC_IN_A**	C	PR58B	3	RLM0_GPLLC_IN_A**/RDQ57	C
VCCIO	VCCIO3	3			VCCIO3	3		
P17	PR43A	3	RLM0_GPLLT_IN_A**	T	PR58A	3	RLM0_GPLLT_IN_A**/RDQ57	T
P20	PR42B	3	RLM0_GPLLC_FB_A	C (LVDS)*	PR57B	3	RLM0_GPLLC_FB_A/RDQ57	C (LVDS)*
P19	PR42A	3	RLM0_GPLLT_FB_A	T (LVDS)*	PR57A	3	RLM0_GPLLT_FB_A/RDQS57****	T (LVDS)*
GNDIO	GNDIO3	-			GNDIO3	-		
-	-	-			VCCIO3	3		
P18	PR41B	3	RDQ38	C	PR51B	3	RDQ48	C
N16	PR41A	3	RDQ38	T	PR51A	3	RDQ48	T
GNDIO	GNDIO3	-			GNDIO3	-		
N22	PR40B	3	RDQ38	C (LVDS)*	PR50B	3	RDQ48	C (LVDS)*
N21	PR40A	3	RDQ38	T (LVDS)*	PR50A	3	RDQ48	T (LVDS)*
N17	PR39B	3	RDQ38	C	PR49B	3	RDQ48	C
N18	PR39A	3	RDQ38	T	PR49A	3	RDQ48	T
VCCIO	VCCIO3	3			VCCIO3	3		
M22	PR38B	3	RDQ38	C (LVDS)*	PR48B	3	RDQ48	C (LVDS)*
M21	PR38A	3	RDQS38	T (LVDS)*	PR48A	3	RDQS48	T (LVDS)*
M16	PR37B	3	RDQ38	C	PR47B	3	RDQ48	C
GNDIO	GNDIO3	-			GNDIO3	-		
M17	PR37A	3	RDQ38	T	PR47A	3	RDQ48	T
M20	PR36B	3	RDQ38	C (LVDS)*	PR46B	3	RDQ48	C (LVDS)*
M19	PR36A	3	RDQ38	T (LVDS)*	PR46A	3	RDQ48	T (LVDS)*
M18	PR35B	3	RDQ38	C	PR45B	3	RDQ48	C
VCCIO	VCCIO3	3			VCCIO3	3		
L16	PR35A	3	RDQ38	T	PR45A	3	RDQ48	T
L22	PR34B	3	RDQ38	C (LVDS)*	PR44B	3	RDQ48	C (LVDS)*
L21	PR34A	3	RDQ38	T (LVDS)*	PR44A	3	RDQ48	T (LVDS)*
K22	PR32B	3	RLM1_SPLLC_FB_A	C	PR42B	3	RLM2_SPLLC_FB_A	C
VCCIO	VCCIO3	3			VCCIO3	3		
K21	PR32A	3	RLM1_SPLLT_FB_A	T	PR42A	3	RLM2_SPLLT_FB_A	T
L17	PR31B	3	RLM1_SPLLC_IN_A	C (LVDS)*	PR41B	3	RLM2_SPLLC_IN_A	C (LVDS)*
L18	PR31A	3	RLM1_SPLLT_IN_A	T (LVDS)*	PR41A	3	RLM2_SPLLT_IN_A	T (LVDS)*
GNDIO	GNDIO3	-			GNDIO3	-		
L20	PR30B	3		C	PR40B	3		C
L19	PR30A	3		T	PR40A	3		T
K16	PR29B	3		C (LVDS)*	PR39B	3		C (LVDS)*
K17	PR29A	3		T (LVDS)*	PR39A	3		T (LVDS)*
VCCIO	VCCIO3	3			VCCIO3	3		

LFE2M20E/SE and LFE2M35E/SE Logic Signal Connections: 484 fpBGA

LFE2M20E/SE					LFE2M35E/SE			
Ball Number	Ball/Pad Function	Bank	Dual Function	Differential	Ball/Pad Function	Bank	Dual Function	Differential
J16	PR28B	3	VREF2_3	C	PR38B	3	VREF2_3	C
K18	PR28A	3	VREF1_3	T	PR38A	3	VREF1_3	T
J22	PR27B	3	PCLKC3_0	C (LVDS)*	PR37B	3	PCLKC3_0	C (LVDS)*
J21	PR27A	3	PCLKT3_0	T (LVDS)*	PR37A	3	PCLKT3_0	T (LVDS)*
H22	PR25B	2	PCLKC2_0/RDQ22	C	PR35B	2	PCLKC2_0/RDQ32	C
H21	PR25A	2	PCLKT2_0/RDQ22	T	PR35A	2	PCLKT2_0/RDQ32	T
GNDIO	GNDIO2	-			GNDIO2	-		
J17	PR24B	2	RDQ22	C (LVDS)*	PR34B	2	RDQ32	C (LVDS)*
J18	PR24A	2	RDQ22	T (LVDS)*	PR34A	2	RDQ32	T (LVDS)*
J20	PR23B	2	RDQ22	C	PR33B	2	RDQ32	C
J19	PR23A	2	RDQ22	T	PR33A	2	RDQ32	T
VCCIO	VCCIO2	2			VCCIO2	2		
H16	PR22B	2	RDQ22	C (LVDS)*	PR32B	2	RDQ32	C (LVDS)*
H17	PR22A	2	RDQS22	T (LVDS)*	PR32A	2	RDQS32	T (LVDS)*
G22	PR21B	2	RDQ22	C	PR31B	2	RDQ32	C
GNDIO	GNDIO2	-			GNDIO2	-		
G21	PR21A	2	RDQ22	T	PR31A	2	RDQ32	T
H20	PR20B	2	RDQ22	C (LVDS)*	PR30B	2	RDQ32	C (LVDS)*
H19	PR20A	2	RDQ22	T (LVDS)*	PR30A	2	RDQ32	T (LVDS)*
G16	PR19B	2	RUM1_SPLL_C_FB_A/RDQ22	C	PR29B	2	RUM1_SPLL_C_FB_A/RDQ32	C
VCCIO	VCCIO2	2			VCCIO2	2		
H18	PR19A	2	RUM1_SPLL_T_FB_A/RDQ22	T	PR29A	2	RUM1_SPLL_T_FB_A/RDQ32	T
F22	PR18B	2	RUM1_SPLL_C_IN_A/RDQ22	C (LVDS)*	PR28B	2	RUM1_SPLL_C_IN_A/RDQ32	C (LVDS)*
F21	PR18A	2	RUM1_SPLL_T_IN_A/RDQ22	T (LVDS)*	PR28A	2	RUM1_SPLL_T_IN_A/RDQ32	T (LVDS)*
GNDIO	GNDIO2	-			-	-		
G20	PR16B	2		C	PR26B	2	RDQ23	C
VCCIO	VCCIO2	2			-	-		
F20	PR16A	2		T	PR26A	2	RDQ23	T
-	-	-			GNDIO2	-		
G17	PR15B	2		C (LVDS)*	PR25B	2	RDQ23	C (LVDS)*
F17	PR15A	2		T (LVDS)*	PR25A	2	RDQ23	T (LVDS)*
-	-	-			VCCIO2	2		
GNDIO	GNDIO2	-			GNDIO2	-		
E22	PR14B	2		C	PR14B	2	RDQ15	C
D22	PR14A	2		T	PR14A	2	RDQ15	T
E20	PR13B	2		C (LVDS)*	PR13B	2	RDQ15	C (LVDS)*
D20	PR13A	2		T (LVDS)*	PR13A	2	RDQ15	T (LVDS)*
VCCIO	VCCIO2	2			VCCIO2	2		
D19	PR12B	2	RUM0_SPLL_C_FB_A	C	PR12B	2	RUM0_SPLL_C_FB_A/RDQ15	C
E19	PR12A	2	RUM0_SPLL_T_FB_A	T	PR12A	2	RUM0_SPLL_T_FB_A/RDQ15	T
F18	PR11B	2	RUM0_SPLL_C_IN_A	C (LVDS)*	PR11B	2	RUM0_SPLL_C_IN_A/RDQ15	C (LVDS)*
F19	PR11A	2	RUM0_SPLL_T_IN_A	T (LVDS)*	PR11A	2	RUM0_SPLL_T_IN_A/RDQ15	T (LVDS)*
E18	PR9B	2	VREF2_2	C	PR9B	2	VREF2_2	C
GNDIO	GNDIO2	-			GNDIO2	-		
D18	PR9A	2	VREF1_2	T	PR9A	2	VREF1_2	T
VCCIO	VCCIO2	2			-	-		
F16	XRES	-			XRES	-		
C22	URC_SQ_VCCR_X0	12			URC_SQ_VCCR_X0	12		
A21	URC_SQ_HDIN_P0	12		T	URC_SQ_HDIN_P0	12		T

LFE2M20E/SE and LFE2M35E/SE Logic Signal Connections: 484 fpBGA

LFE2M20E/SE					LFE2M35E/SE				
Ball Number	Ball/Pad Function	Bank	Dual Function	Differential	Ball/Pad Function	Bank	Dual Function	Differential	
B22	URC_SQ_VCCIB0	12			URC_SQ_VCCIB0	12			
B21	URC_SQ_HDINN0	12		C	URC_SQ_HDINN0	12		C	
C19	URC_SQ_VCCTX0	12			URC_SQ_VCCTX0	12			
A18	URC_SQ_HDOUPT ₀	12		T	URC_SQ_HDOUPT ₀	12		T	
A19	URC_SQ_VCCOB0	12			URC_SQ_VCCOB0	12			
B18	URC_SQ_HDOUPTN ₀	12		C	URC_SQ_HDOUPTN ₀	12		C	
C18	URC_SQ_VCCTX1	12			URC_SQ_VCCTX1	12			
B17	URC_SQ_HDOUPTN ₁	12		C	URC_SQ_HDOUPTN ₁	12		C	
C17	URC_SQ_VCCOB1	12			URC_SQ_VCCOB1	12			
A17	URC_SQ_HDOUPT ₁	12		T	URC_SQ_HDOUPT ₁	12		T	
C21	URC_SQ_VCCRX1	12			URC_SQ_VCCRX1	12			
B20	URC_SQ_HDINN1	12		C	URC_SQ_HDINN1	12		C	
C20	URC_SQ_VCCIB1	12			URC_SQ_VCCIB1	12			
A20	URC_SQ_HDINP1	12		T	URC_SQ_HDINP1	12		T	
B16	URC_SQ_VCCAUX ₃₃	12			URC_SQ_VCCAUX ₃₃	12			
E17	URC_SQ_REFCLK _N	12		C	URC_SQ_REFCLK _N	12		C	
D17	URC_SQ_REFCLK _P	12		T	URC_SQ_REFCLK _P	12		T	
C16	URC_SQ_VCCP	12			URC_SQ_VCCP	12			
A12	URC_SQ_HDINP2	12		T	URC_SQ_HDINP2	12		T	
C12	URC_SQ_VCCIB2	12			URC_SQ_VCCIB2	12			
B12	URC_SQ_HDINN2	12		C	URC_SQ_HDINN2	12		C	
C11	URC_SQ_VCCRX2	12			URC_SQ_VCCRX2	12			
A15	URC_SQ_HDOUPT ₂	12		T	URC_SQ_HDOUPT ₂	12		T	
C15	URC_SQ_VCCOB2	12			URC_SQ_VCCOB2	12			
B15	URC_SQ_HDOUPTN ₂	12		C	URC_SQ_HDOUPTN ₂	12		C	
C14	URC_SQ_VCCTX2	12			URC_SQ_VCCTX2	12			
B14	URC_SQ_HDOUPTN ₃	12		C	URC_SQ_HDOUPTN ₃	12		C	
A13	URC_SQ_VCCOB3	12			URC_SQ_VCCOB3	12			
A14	URC_SQ_HDOUPT ₃	12		T	URC_SQ_HDOUPT ₃	12		T	
C13	URC_SQ_VCCTX3	12			URC_SQ_VCCTX3	12			
B11	URC_SQ_HDINN3	12		C	URC_SQ_HDINN3	12		C	
B10	URC_SQ_VCCIB3	12			URC_SQ_VCCIB3	12			
A11	URC_SQ_HDINP3	12		T	URC_SQ_HDINP3	12		T	
C10	URC_SQ_VCCRX3	12			URC_SQ_VCCRX3	12			
E13	PT28B	1		C	PT46B	1		C	
D12	PT28A	1		T	PT46A	1		T	
GNDIO	GNDIO1	-			GNDIO1	-			
A9	PT27B	1		C	PT45B	1		C	
A8	PT27A	1		T	PT45A	1		T	
A7	PT26B	1		C	PT44B	1		C	
A6	PT26A	1		T	PT44A	1		T	
VCCIO	VCCIO1	1			VCCIO1	1			
E12	PT25B	1		C	PT43B	1		C	

LFE2M20E/SE and LFE2M35E/SE Logic Signal Connections: 484 fpBGA

LFE2M20E/SE					LFE2M35E/SE			
Ball Number	Ball/Pad Function	Bank	Dual Function	Differential	Ball/Pad Function	Bank	Dual Function	Differential
F12	PT25A	1		T	PT43A	1		T
A5	PT24B	1		C	PT42B	1		C
A4	PT24A	1		T	PT42A	1		T
GNDIO	GNDIO1	-			GNDIO1	-		
B7	PT23B	1		C	PT41B	1		C
B8	PT23A	1		T	PT41A	1		T
G11	PT22B	1		C	PT40B	1		C
E11	PT22A	1		T	PT40A	1		T
VCCIO	VCCIO1	1			VCCIO1	1		
D11	PT21B	1	VREF2_1	C	PT39B	1	VREF2_1	C
D10	PT21A	1	VREF1_1	T	PT39A	1	VREF1_1	T
F11	PT20A	1	PCLKT1_0	T	PT38A	1	PCLKC1_0	C
G10	PT20B	1	PCLKC1_0	C	PT38B	1	PCLKT1_0	T
G9	PT19B	0	PCLKC0_0	C	PT37B	0	PCLKC0_0	C
GNDIO	GNDIO0	-			GNDIO0	-		
F9	PT19A	0	PCLKT0_0	T	PT37A	0	PCLKT0_0	T
C9	PT18B	0	VREF2_0	C	PT36B	0	VREF2_0	C
D9	PT18A	0	VREF1_0	T	PT36A	0	VREF1_0	T
A2	PT17B	0		C	PT35B	0		C
VCCIO	VCCIO0	0			VCCIO0	0		
A3	PT17A	0		T	PT35A	0		T
B3	PT16B	0		C	PT34B	0		C
C4	PT16A	0		T	PT34A	0		T
E10	PT15B	0		C	PT33B	0		C
F10	PT15A	0		T	PT33A	0		T
C7	PT14B	0		C	PT32B	0		C
GNDIO	GNDIO0	-			GNDIO0	-		
B6	PT14A	0		T	PT32A	0		T
C6	PT13B	0		C	PT31B	0		C
VCCIO	VCCIO0	0			VCCIO0	0		
C5	PT13A	0		T	PT31A	0		T
C8	PT12B	0		C	PT30B	0		C
D8	PT12A	0		T	PT30A	0		T
E8	PT11B	0		C	PT29B	0		C
E9	PT11A	0		T	PT29A	0		T
-	-	-			GNDIO0	-		
-	-	-			VCCIO0	0		
F8	PT10B	0		C	PT10B	0		C
G8	PT10A	0		T	PT10A	0		T
GNDIO	GNDIO0	-			GNDIO0	-		
F7	PT9B	0		C	PT9B	0		C
G7	PT9A	0		T	PT9A	0		T
C3	PT8B	0		C	PT8B	0		C
D4	PT8A	0		T	PT8A	0		T
VCCIO	VCCIO0	0			VCCIO0	0		
F6	PT7B	0		C	PT7B	0		C
E6	PT7A	0		T	PT7A	0		T
E5	PT6B	0		C	PT6B	0		C
D6	PT6A	0		T	PT6A	0		T

LFE2M20E/SE and LFE2M35E/SE Logic Signal Connections: 484 fpBGA

LFE2M20E/SE					LFE2M35E/SE			
Ball Number	Ball/Pad Function	Bank	Dual Function	Differential	Ball/Pad Function	Bank	Dual Function	Differential
GNDIO	GNDIO0	-			GNDIO0	-		
D3	PT5B	0		C	PT5B	0		C
E3	PT5A	0		T	PT5A	0		T
D5	PT4B	0		C	PT4B	0		C
E4	PT4A	0		T	PT4A	0		T
VCCIO	VCCIO0	0			VCCIO0	0		
C2	PT3B	0		C	PT3B	0		C
B2	PT3A	0		T	PT3A	0		T
B1	PT2B	0		C	PT2B	0		C
C1	PT2A	0		T	PT2A	0		T
R8	VCCPLL	-			VCCPLL	-		
H15	VCCPLL	-			VCCPLL	-		
H8	VCCPLL	-			VCCPLL	-		
R15	VCCPLL	-			VCCPLL	-		
J10	VCC	-			VCC	-		
J11	VCC	-			VCC	-		
J12	VCC	-			VCC	-		
J13	VCC	-			VCC	-		
K14	VCC	-			VCC	-		
K9	VCC	-			VCC	-		
L14	VCC	-			VCC	-		
L9	VCC	-			VCC	-		
M14	VCC	-			VCC	-		
M9	VCC	-			VCC	-		
N14	VCC	-			VCC	-		
N9	VCC	-			VCC	-		
P10	VCC	-			VCC	-		
P11	VCC	-			VCC	-		
P12	VCC	-			VCC	-		
P13	VCC	-			VCC	-		
B5	VCCIO0	0			VCCIO0	0		
B9	VCCIO0	0			VCCIO0	0		
E7	VCCIO0	0			VCCIO0	0		
H9	VCCIO0	0			VCCIO0	0		
D13	VCCIO1	1			VCCIO1	1		
E16	VCCIO1	1			VCCIO1	1		
H14	VCCIO1	1			VCCIO1	1		
E21	VCCIO2	2			VCCIO2	2		
G18	VCCIO2	2			VCCIO2	2		
J15	VCCIO2	2			VCCIO2	2		
K19	VCCIO2	2			VCCIO2	2		
N19	VCCIO3	3			VCCIO3	3		
P15	VCCIO3	3			VCCIO3	3		
T18	VCCIO3	3			VCCIO3	3		
V21	VCCIO3	3			VCCIO3	3		
AA18	VCCIO4	4			VCCIO4	4		
R14	VCCIO4	4			VCCIO4	4		
V16	VCCIO4	4			VCCIO4	4		
W13	VCCIO4	4			VCCIO4	4		

LFE2M20E/SE and LFE2M35E/SE Logic Signal Connections: 484 fpBGA

LFE2M20E/SE					LFE2M35E/SE			
Ball Number	Ball/Pad Function	Bank	Dual Function	Differential	Ball/Pad Function	Bank	Dual Function	Differential
AA5	VCCIO5	5			VCCIO5	5		
R9	VCCIO5	5			VCCIO5	5		
V7	VCCIO5	5			VCCIO5	5		
W10	VCCIO5	5			VCCIO5	5		
N4	VCCIO6	6			VCCIO6	6		
P8	VCCIO6	6			VCCIO6	6		
T5	VCCIO6	6			VCCIO6	6		
V2	VCCIO6	6			VCCIO6	6		
E2	VCCIO7	7			VCCIO7	7		
G5	VCCIO7	7			VCCIO7	7		
J8	VCCIO7	7			VCCIO7	7		
K4	VCCIO7	7			VCCIO7	7		
AA22	VCCIO8	8			VCCIO8	8		
U19	VCCIO8	8			VCCIO8	8		
H11	VCCAUX	-			VCCAUX	-		
H12	VCCAUX	-			VCCAUX	-		
L15	VCCAUX	-			VCCAUX	-		
L8	VCCAUX	-			VCCAUX	-		
M15	VCCAUX	-			VCCAUX	-		
M8	VCCAUX	-			VCCAUX	-		
R11	VCCAUX	-			VCCAUX	-		
R12	VCCAUX	-			VCCAUX	-		
A1	GND	-			GND	-		
A10	GND	-			GND	-		
A16	GND	-			GND	-		
A22	GND	-			GND	-		
AA19	GND	-			GND	-		
AA4	GND	-			GND	-		
AB1	GND	-			GND	-		
AB22	GND	-			GND	-		
B13	GND	-			GND	-		
B19	GND	-			GND	-		
B4	GND	-			GND	-		
D16	GND	-			GND	-		
D2	GND	-			GND	-		
D21	GND	-			GND	-		
D7	GND	-			GND	-		
G19	GND	-			GND	-		
G4	GND	-			GND	-		
H10	GND	-			GND	-		
H13	GND	-			GND	-		
J14	GND	-			GND	-		
J9	GND	-			GND	-		
K10	GND	-			GND	-		
K11	GND	-			GND	-		
K12	GND	-			GND	-		
K13	GND	-			GND	-		
K15	GND	-			GND	-		
K20	GND	-			GND	-		

LFE2M20E/SE and LFE2M35E/SE Logic Signal Connections: 484 fpBGA

LFE2M20E/SE					LFE2M35E/SE			
Ball Number	Ball/Pad Function	Bank	Dual Function	Differential	Ball/Pad Function	Bank	Dual Function	Differential
K3	GND	-			GND	-		
K8	GND	-			GND	-		
L10	GND	-			GND	-		
L11	GND	-			GND	-		
L12	GND	-			GND	-		
L13	GND	-			GND	-		
M10	GND	-			GND	-		
M11	GND	-			GND	-		
M12	GND	-			GND	-		
M13	GND	-			GND	-		
N10	GND	-			GND	-		
N11	GND	-			GND	-		
N12	GND	-			GND	-		
N13	GND	-			GND	-		
N15	GND	-			GND	-		
N20	GND	-			GND	-		
N3	GND	-			GND	-		
N8	GND	-			GND	-		
P14	GND	-			GND	-		
P9	GND	-			GND	-		
R10	GND	-			GND	-		
R13	GND	-			GND	-		
T19	GND	-			GND	-		
T4	GND	-			GND	-		
W16	GND	-			GND	-		
W2	GND	-			GND	-		
W21	GND	-			GND	-		
W7	GND	-			GND	-		
Y10	GND	-			GND	-		
Y13	GND	-			GND	-		
D15	NC	-			NC	-		
G14	NC	-			NC	-		
G15	NC	-			NC	-		
D14	NC	-			NC	-		
E15	NC	-			NC	-		
E14	NC	-			NC	-		
F15	NC	-			NC	-		
F14	NC	-			NC	-		
F13	NC	-			NC	-		
G12	NC	-			NC	-		
G13	NC	-			NC	-		

* Supports true LVDS. Other differential signals must be emulated with external resistors.

** These dedicated input pins can be used for GPLLs or GDLLs within the respective quadrant.

***For density migration, board design must take into account that these sysCONFIG pins are dual function for the lower density devices (ECP2M20 and ECP2M35) and are dedicated pins for the higher density devices (ECP2M50, ECP2M70 and ECP2M100).

****Due to packaging bond out option, this DQS does not have all the necessary DQ pins bonded out for a full 8-bit data width.

Note: VCCIO and GND pads are used to determine the average DC current drawn by I/Os between GND/VCCIO connections, or between the last GND/VCCIO in an I/O bank and the end of an I/O bank. The substrate pads listed in the Pin Table do not necessarily have a one to one connection with a package ball or pin.

LFE2M50E/SE Logic Signal Connections: 484 fpBGA

LFE2M50E/SE				
Ball Number	Ball/Pad Function	Bank	Dual Function	Differential
D1	PL2A	7	LDQ6	T (LVDS)*
E1	PL2B	7	LDQ6	C (LVDS)*
F1	PL3A	7	LDQ6	T
F2	PL3B	7	LDQ6	C
F5	PL4A	7	LDQ6	T (LVDS)*
VCCIO	VCCIO7	7		
G6	PL4B	7	LDQ6	C (LVDS)*
F4	PL5A	7	LDQ6	T
F3	PL5B	7	LDQ6	C
G1	PL6A	7	LDQS6	T (LVDS)*
GNDIO	GNDIO7	-		
G2	PL6B	7	LDQ6	C (LVDS)*
H1	PL7A	7	LDQ6	T
H2	PL7B	7	LDQ6	C
VCCIO	VCCIO7	7		
H7	PL8A	7	LDQ6	T (LVDS)*
H6	PL8B	7	LDQ6	C (LVDS)*
G3	PL9A	7	VREF2_7/LDQ6	T
H3	PL9B	7	VREF1_7/LDQ6	C
GNDIO	GNDIO7	-		
VCCIO	VCCIO7	7		
H5	PL11A	7	LUM0_SPLLT_IN_A	T (LVDS)*
H4	PL11B	7	LUM0_SPLLC_IN_A	C (LVDS)*
J1	PL12A	7	LUM0_SPLLT_FB_A	T
J2	PL12B	7	LUM0_SPLLC_FB_A	C
GNDIO	GNDIO7	-		
J3	PL13A	7		T (LVDS)*
J4	PL13B	7		C (LVDS)*
J7	PL14A	7		T
VCCIO	VCCIO7	7		
J6	PL14B	7		C
GNDIO	GNDIO7	-		
VCCIO	VCCIO7	7		
K1	PL32A	7	LUM3_SPLLT_IN_A/LDQ36	T (LVDS)*
K2	PL32B	7	LUM3_SPLLC_IN_A/LDQ36	C (LVDS)*
J5	PL33A	7	LUM3_SPLLT_FB_A/LDQ36	T
K5	PL33B	7	LUM3_SPLLC_FB_A/LDQ36	C
VCCIO	VCCIO7	7		
K7	PL34A	7	LDQ36	T (LVDS)*
K6	PL34B	7	LDQ36	C (LVDS)*
L6	PL35A	7	LDQ36	T
L7	PL35B	7	LDQ36	C

LFE2M50E/SE Logic Signal Connections: 484 fpBGA (Cont.)

LFE2M50E/SE				
Ball Number	Ball/Pad Function	Bank	Dual Function	Differential
GNDIO	GNDIO7	-		
L1	PL36A	7	LDQS36	T (LVDS)*
L2	PL36B	7	LDQ36	C (LVDS)*
M7	PL37A	7	LDQ36	T
VCCIO	VCCIO7	7		
L5	PL37B	7	LDQ36	C
L3	PL38A	7	LDQ36	T (LVDS)*
L4	PL38B	7	LDQ36	C (LVDS)*
M1	PL39A	7	PCLKT7_0/LDQ36	T
GNDIO	GNDIO7	-		
M2	PL39B	7	PCLKC7_0/LDQ36	C
M6	PL41A	6	PCLKT6_0	T (LVDS)*
M5	PL41B	6	PCLKC6_0	C (LVDS)*
M3	PL42A	6	VREF2_6	T
M4	PL42B	6	VREF1_6	C
VCCIO	VCCIO6	6		
N7	PL45A	6	LLM3_SPLLT_IN_A	T (LVDS)*
GNDIO	GNDIO6	-		
N6	PL45B	6	LLM3_SPLLC_IN_A	C (LVDS)*
N1	PL46A	6	LLM3_SPLLT_FB_A	T
N2	PL46B	6	LLM3_SPLLC_FB_A	C
VCCIO	VCCIO6	6		
GNDIO	GNDIO6	-		
P6	PL52A	6	LDQS52****	T (LVDS)*
N5	PL52B	6	LDQ52	C (LVDS)*
P1	PL53A	6	LDQ52	T
VCCIO	VCCIO6	6		
P2	PL53B	6	LDQ52	C
P3	PL54A	6	LDQ52	T (LVDS)*
P4	PL54B	6	LDQ52	C (LVDS)*
P5	PL55A	6	LDQ52	T
GNDIO	GNDIO6	-		
P7	PL55B	6	LDQ52	C
VCCIO	VCCIO6	6		
GNDIO	GNDIO6	-		
R1	PL62A	6	LLM0_GPLLT_IN_A**	T (LVDS)*
GNDIO	GNDIO6	-		
R2	PL62B	6	LLM0_GPLLC_IN_A**	C (LVDS)*
R3	PL63A	6	LLM0_GPLLT_FB_A	T
R4	PL63B	6	LLM0_GPLLC_FB_A	C
VCCIO	VCCIO6	6		
R6	PL64A	6	LLM0_GDLLT_IN_A**	T (LVDS)*
R5	PL64B	6	LLM0_GDLLC_IN_A**	C (LVDS)*

LFE2M50E/SE Logic Signal Connections: 484 fpBGA (Cont.)

LFE2M50E/SE				
Ball Number	Ball/Pad Function	Bank	Dual Function	Differential
T1	PL65A	6	LLM0_GDLLT_FB_A	T
T2	PL65B	6	LLM0_GDLLC_FB_A	C
GNDIO	GNDIO6	-		
R7	LLM0_PLLCAP	6		
T6	PL67A	6	LDQ71	T (LVDS)*
T7	PL67B	6	LDQ71	C (LVDS)*
U1	PL68A	6	LDQ71	T
U2	PL68B	6	LDQ71	C
VCCIO	VCCIO6	6		
T3	PL69A	6	LDQ71	T (LVDS)*
U3	PL69B	6	LDQ71	C (LVDS)*
U6	PL70A	6	LDQ71	T
U5	PL70B	6	LDQ71	C
GNDIO	GNDIO6	-		
V5	PL71A	6	LDQS71	T (LVDS)*
U4	PL71B	6	LDQ71	C (LVDS)*
V1	PL72A	6	LDQ71	T
VCCIO	VCCIO6	6		
V3	PL72B	6	LDQ71	C
W1	PL73A	6	LDQ71	T (LVDS)*
Y1	PL73B	6	LDQ71	C (LVDS)*
AA1	PL74A	6	LDQ71	T
GNDIO	GNDIO6	-		
AA2	PL74B	6	LDQ71	C
V4	TCK	-		
Y2	TDI	-		
Y3	TMS	-		
W3	TDO	-		
W4	VCCJ	-		
W5	PB2A	5	BDQ6	T
Y4	PB2B	5	BDQ6	C
W6	PB3A	5	BDQ6	T
V6	PB3B	5	BDQ6	C
AA3	PB4A	5	BDQ6	T
AB2	PB4B	5	BDQ6	C
VCCIO	VCCIO5	5		
T8	PB5A	5	BDQ6	T
U7	PB5B	5	BDQ6	C
GNDIO	GNDIO5	-		
U8	PB6A	5	BDQS6	T
T9	PB6B	5	BDQ6	C
V8	PB7A	5	BDQ6	T
W8	PB7B	5	BDQ6	C

LFE2M50E/SE Logic Signal Connections: 484 fpBGA (Cont.)

LFE2M50E/SE				
Ball Number	Ball/Pad Function	Bank	Dual Function	Differential
Y6	PB8A	5	BDQ6	T
Y5	PB8B	5	BDQ6	C
VCCIO	VCCIO5	5		
AB3	PB9A	5	BDQ6	T
AB4	PB9B	5	BDQ6	C
AB5	PB10A	5	BDQ6	T
AA6	PB10B	5	BDQ6	C
GNDIO	GNDIO5	-		
VCCIO	VCCIO5	5		
V9	PB40A	5	BDQ42	T
U9	PB40B	5	BDQ42	C
VCCIO	VCCIO5	5		
U10	PB41A	5	BDQ42	T
T10	PB41B	5	BDQ42	C
GNDIO	GNDIO5	-		
W9	PB42A	5	BDQS42****	T
Y8	PB42B	5	BDQ42	C
AA7	PB43A	5	VREF2_5/BDQ42	T
Y7	PB43B	5	VREF1_5/BDQ42	C
AB6	PB44A	5	PCLKT5_0/BDQ42	T
AB7	PB44B	5	PCLKC5_0/BDQ42	C
VCCIO	VCCIO5	5		
GNDIO	GNDIO5	-		
AA8	PB49A	4	PCLKT4_0/BDQ51	T
VCCIO	VCCIO4	4		
AB8	PB49B	4	PCLKC4_0/BDQ51	C
AA9	PB50A	4	VREF2_4/BDQ51	T
Y9	PB50B	4	VREF1_4/BDQ51	C
AB9	PB51A	4	BDQS51****	T
GNDIO	GNDIO4	-		
AB10	PB51B	4	BDQ51	C
AA10	PB52A	4	BDQ51	T
Y11	PB52B	4	BDQ51	C
VCCIO	VCCIO4	4		
GNDIO	GNDIO4	-		
V10	PB56A	4	BDQ60	T
U11	PB56B	4	BDQ60	C
V11	PB57A	4	BDQ60	T
W11	PB57B	4	BDQ60	C
AA11	PB58A	4	BDQ60	T
AB11	PB58B	4	BDQ60	C
VCCIO	VCCIO4	4		
T11	PB59A	4	BDQ60	T

LFE2M50E/SE Logic Signal Connections: 484 fpBGA (Cont.)

LFE2M50E/SE				
Ball Number	Ball/Pad Function	Bank	Dual Function	Differential
U12	PB59B	4	BDQ60	C
GNDIO	GNDIO4	-		
AA12	PB60A	4	BDQS60	T
Y12	PB60B	4	BDQ60	C
V12	PB61A	4	BDQ60	T
W12	PB61B	4	BDQ60	C
AB12	PB62A	4	BDQ60	T
AA13	PB62B	4	BDQ60	C
VCCIO	VCCIO4	4		
T12	PB63A	4	BDQ60	T
U13	PB63B	4	BDQ60	C
V13	PB64A	4	BDQ60	T
T13	PB64B	4	BDQ60	C
GNDIO	GNDIO4	-		
AB13	PB65A	4	BDQ69	T
AB14	PB65B	4	BDQ69	C
U14	PB66A	4	BDQ69	T
T14	PB66B	4	BDQ69	C
AA14	PB67A	4	BDQ69	T
VCCIO	VCCIO4	4		
Y14	PB67B	4	BDQ69	C
W14	PB68A	4	BDQ69	T
V14	PB68B	4	BDQ69	C
AB15	PB69A	4	BDQS69	T
GNDIO	GNDIO4	-		
AA15	PB69B	4	BDQ69	C
V15	PB70A	4	BDQ69	T
U15	PB70B	4	BDQ69	C
AB16	PB71A	4	BDQ69	T
VCCIO	VCCIO4	4		
AA16	PB71B	4	BDQ69	C
AB17	PB72A	4	BDQ69	T
AA17	PB72B	4	BDQ69	C
GNDIO	GNDIO4	-		
W20	CFG2	8		
V20	CFG1	8		
V19	CFG0	8		
V22	PROGRAMN	8		
W22	CCLK	8		
U18	INITN	8		
U22	DONE	8		
GNDIO	GNDIO8	-		
U20	WRITEN***	8		

LFE2M50E/SE Logic Signal Connections: 484 fpBGA (Cont.)

LFE2M50E/SE				
Ball Number	Ball/Pad Function	Bank	Dual Function	Differential
U21	CS1N***	8		
U17	CSN***	8		
U16	D0/SPIFASTN***	8		
VCCIO	VCCIO8	8		
T16	D1***	8		
T17	D2***	8		
T22	D3***	8		
GNDIO	GNDIO8	-		
R22	D4***	8		
T15	D5***	8		
R17	D6***	8		
T20	D7***	8		
VCCIO	VCCIO8	8		
T21	DI/CSSPI0N***	8		
R21	DOUT/CSON/CSSPI1N***	8		
R20	BUSY/SISPI***	8		
R16	RLM0_PLLCAP	3		
R18	PR65B	3	RLM0_GDLLC_FB_A	C
GNDIO	GNDIO3	-		
R19	PR65A	3	RLM0_GDLLT_FB_A	T
P22	PR64B	3	RLM0_GDLLC_IN_A**	C (LVDS)*
P21	PR64A	3	RLM0_GDLLT_IN_A**	T (LVDS)*
P16	PR63B	3	RLM0_GPLL_C_IN_A**	C
VCCIO	VCCIO3	3		
P17	PR63A	3	RLM0_GPLLT_IN_A**	T
P20	PR62B	3	RLM0_GPLL_C_FB_A	C (LVDS)*
P19	PR62A	3	RLM0_GPLLT_FB_A	T (LVDS)*
GNDIO	GNDIO3	-		
VCCIO	VCCIO3	3		
P18	PR55B	3	RDQ52	C
N16	PR55A	3	RDQ52	T
GNDIO	GNDIO3	-		
N22	PR54B	3	RDQ52	C (LVDS)*
N21	PR54A	3	RDQ52	T (LVDS)*
N17	PR53B	3	RDQ52	C
N18	PR53A	3	RDQ52	T
VCCIO	VCCIO3	3		
M22	PR52B	3	RDQ52	C (LVDS)*
M21	PR52A	3	RDQS52	T (LVDS)*
M16	PR51B	3	RDQ52	C
GNDIO	GNDIO3	-		
M17	PR51A	3	RDQ52	T
M20	PR50B	3	RDQ52	C (LVDS)*

LFE2M50E/SE Logic Signal Connections: 484 fpBGA (Cont.)

LFE2M50E/SE				
Ball Number	Ball/Pad Function	Bank	Dual Function	Differential
M19	PR50A	3	RDQ52	T (LVDS)*
M18	PR49B	3	RDQ52	C
VCCIO	VCCIO3	3		
L16	PR49A	3	RDQ52	T
L22	PR48B	3	RDQ52	C (LVDS)*
L21	PR48A	3	RDQ52	T (LVDS)*
GNDIO	GNDIO3	-		
K22	PR46B	3	RLM3_SPLLC_FB_A	C
VCCIO	VCCIO3	3		
K21	PR46A	3	RLM3_SPLLT_FB_A	T
L17	PR45B	3	RLM3_SPLLC_IN_A	C (LVDS)*
L18	PR45A	3	RLM3_SPLLT_IN_A	T (LVDS)*
GNDIO	GNDIO3	-		
L20	PR44B	3		C
L19	PR44A	3		T
K16	PR43B	3		C (LVDS)*
K17	PR43A	3		T (LVDS)*
VCCIO	VCCIO3	3		
J16	PR42B	3	VREF2_3	C
K18	PR42A	3	VREF1_3	T
J22	PR41B	3	PCLKC3_0	C (LVDS)*
J21	PR41A	3	PCLKT3_0	T (LVDS)*
H22	PR39B	2	PCLKC2_0/RDQ36	C
H21	PR39A	2	PCLKT2_0/RDQ36	T
GNDIO	GNDIO2	-		
J17	PR38B	2	RDQ36	C (LVDS)*
J18	PR38A	2	RDQ36	T (LVDS)*
J20	PR37B	2	RDQ36	C
J19	PR37A	2	RDQ36	T
VCCIO	VCCIO2	2		
H16	PR36B	2	RDQ36	C (LVDS)*
H17	PR36A	2	RDQS36	T (LVDS)*
G22	PR35B	2	RDQ36	C
GNDIO	GNDIO2	-		
G21	PR35A	2	RDQ36	T
H20	PR34B	2	RDQ36	C (LVDS)*
H19	PR34A	2	RDQ36	T (LVDS)*
G16	PR33B	2	RUM3_SPLLC_FB_A/RDQ36	C
VCCIO	VCCIO2	2		
H18	PR33A	2	RUM3_SPLLT_FB_A/RDQ36	T
F22	PR32B	2	RUM3_SPLLC_IN_A/RDQ36	C (LVDS)*
F21	PR32A	2	RUM3_SPLLT_IN_A/RDQ36	T (LVDS)*
G20	PR30B	2	RDQ27	C

LFE2M50E/SE Logic Signal Connections: 484 fpBGA (Cont.)

LFE2M50E/SE				
Ball Number	Ball/Pad Function	Bank	Dual Function	Differential
F20	PR30A	2	RDQ27	T
GNDIO	GNDIO2	-		
G17	PR29B	2	RDQ27	C (LVDS)*
F17	PR29A	2	RDQ27	T (LVDS)*
VCCIO	VCCIO2	2		
GNDIO	GNDIO2	-		
E22	PR14B	2		C
D22	PR14A	2		T
VCCIO	VCCIO2	-		
E20	PR13B	2		C (LVDS)*
D20	PR13A	2		T (LVDS)*
D19	PR12B	2	RUM0_SPLLC_FB_A	C
GNDIO	GNDIO2	-		
E19	PR12A	2	RUM0_SPLLT_FB_A	T
F18	PR11B	2	RUM0_SPLLC_IN_A	C (LVDS)*
F19	PR11A	2	RUM0_SPLLT_IN_A	T (LVDS)*
VCCIO	VCCIO2	-		
E18	PR9B	2	VREF2_2	C
GNDIO	GNDIO2	-		
D18	PR9A	2	VREF1_2	T
VCCIO	VCCIO2	2		
F16	XRES	-		
C22	URC_SQ_VCCR0	12		
A21	URC_SQ_HDINP0	12		T
B22	URC_SQ_VCCIB0	12		
B21	URC_SQ_HDINN0	12		C
C19	URC_SQ_VCCTX0	12		
A18	URC_SQ_HDOUTP0	12		T
A19	URC_SQ_VCCOB0	12		
B18	URC_SQ_HDOUTN0	12		C
C18	URC_SQ_VCCTX1	12		
B17	URC_SQ_HDOUTN1	12		C
C17	URC_SQ_VCCOB1	12		
A17	URC_SQ_HDOUTP1	12		T
C21	URC_SQ_VCCR1	12		
B20	URC_SQ_HDINN1	12		C
C20	URC_SQ_VCCIB1	12		
A20	URC_SQ_HDINP1	12		T
B16	URC_SQ_VCCAUX33	12		
E17	URC_SQ_REFCLKN	12		C
D17	URC_SQ_REFCLKP	12		T
C16	URC_SQ_VCCP	12		
A12	URC_SQ_HDINP2	12		T

LFE2M50E/SE Logic Signal Connections: 484 fpBGA (Cont.)

LFE2M50E/SE				
Ball Number	Ball/Pad Function	Bank	Dual Function	Differential
C12	URC_SQ_VCCIB2	12		
B12	URC_SQ_HDINN2	12		C
C11	URC_SQ_VCCR2	12		
A15	URC_SQ_HDOU2	12		T
C15	URC_SQ_VCCOB2	12		
B15	URC_SQ_HDOU2N	12		C
C14	URC_SQ_VCCTX2	12		
B14	URC_SQ_HDOU2N3	12		C
A13	URC_SQ_VCCOB3	12		
A14	URC_SQ_HDOU2P3	12		T
C13	URC_SQ_VCCTX3	12		
B11	URC_SQ_HDINN3	12		C
B10	URC_SQ_VCCIB3	12		
A11	URC_SQ_HDINP3	12		T
C10	URC_SQ_VCCR3	12		
GNDIO	GNDIO1	-		
VCCIO	VCCIO1	1		
E13	PT55B	1		C
D12	PT55A	1		T
GNDIO	GNDIO1	-		
A9	PT54B	1		C
A8	PT54A	1		T
A7	PT53B	1		C
A6	PT53A	1		T
VCCIO	VCCIO1	1		
E12	PT52B	1		C
F12	PT52A	1		T
A5	PT51B	1		C
A4	PT51A	1		T
GNDIO	GNDIO1	-		
B7	PT50B	1		C
B8	PT50A	1		T
G11	PT49B	1		C
E11	PT49A	1		T
VCCIO	VCCIO1	1		
D11	PT48B	1	VREF2_1	C
D10	PT48A	1	VREF1_1	T
G10	PT47B	1	PCLKC1_0	C
F11	PT47A	1	PCLKT1_0	T
G9	PT46B	0	PCLKC0_0	C
GNDIO	GNDIO0	-		
F9	PT46A	0	PCLKT0_0	T
C9	PT45B	0	VREF2_0	C

LFE2M50E/SE Logic Signal Connections: 484 fpBGA (Cont.)

LFE2M50E/SE				
Ball Number	Ball/Pad Function	Bank	Dual Function	Differential
D9	PT45A	0	VREF1_0	T
A2	PT44B	0		C
VCCIO	VCCIO0	0		
A3	PT44A	0		T
B3	PT43B	0		C
C4	PT43A	0		T
E10	PT42B	0		C
F10	PT42A	0		T
C7	PT41B	0		C
GNDIO	GNDIO0	-		
B6	PT41A	0		T
C6	PT40B	0		C
VCCIO	VCCIO0	0		
C5	PT40A	0		T
C8	PT39B	0		C
D8	PT39A	0		T
E8	PT38B	0		C
E9	PT38A	0		T
GNDIO	GNDIO0	-		
VCCIO	VCCIO0	0		
F8	PT10B	0		C
GNDIO	GNDIO0	-		
G8	PT10A	0		T
F7	PT9B	0		C
G7	PT9A	0		T
C3	PT8B	0		C
VCCIO	VCCIO0	0		
D4	PT8A	0		T
F6	PT7B	0		C
E6	PT7A	0		T
E5	PT6B	0		C
D6	PT6A	0		T
D3	PT5B	0		C
GNDIO	GNDIO0	-		
E3	PT5A	0		T
D5	PT4B	0		C
VCCIO	VCCIO0	0		
E4	PT4A	0		T
C2	PT3B	0		C
B2	PT3A	0		T
B1	PT2B	0		C
C1	PT2A	0		T
J10	VCC	-		

LFE2M50E/SE Logic Signal Connections: 484 fpBGA (Cont.)

LFE2M50E/SE				
Ball Number	Ball/Pad Function	Bank	Dual Function	Differential
J11	VCC	-		
J12	VCC	-		
J13	VCC	-		
K14	VCC	-		
K9	VCC	-		
L14	VCC	-		
L9	VCC	-		
M14	VCC	-		
M9	VCC	-		
N14	VCC	-		
N9	VCC	-		
P10	VCC	-		
P11	VCC	-		
P12	VCC	-		
P13	VCC	-		
B5	VCCIO0	0		
B9	VCCIO0	0		
E7	VCCIO0	0		
H9	VCCIO0	0		
D13	VCCIO1	1		
E16	VCCIO1	1		
H14	VCCIO1	1		
E21	VCCIO2	2		
G18	VCCIO2	2		
J15	VCCIO2	2		
K19	VCCIO2	2		
N19	VCCIO3	3		
P15	VCCIO3	3		
T18	VCCIO3	3		
V21	VCCIO3	3		
AA18	VCCIO4	4		
R14	VCCIO4	4		
V16	VCCIO4	4		
W13	VCCIO4	4		
AA5	VCCIO5	5		
R9	VCCIO5	5		
V7	VCCIO5	5		
W10	VCCIO5	5		
N4	VCCIO6	6		
P8	VCCIO6	6		
T5	VCCIO6	6		
V2	VCCIO6	6		
E2	VCCIO7	7		

LFE2M50E/SE Logic Signal Connections: 484 fpBGA (Cont.)

LFE2M50E/SE				
Ball Number	Ball/Pad Function	Bank	Dual Function	Differential
G5	VCCIO7	7		
J8	VCCIO7	7		
K4	VCCIO7	7		
AA22	VCCIO8	8		
U19	VCCIO8	8		
H11	VCCAUX	-		
H12	VCCAUX	-		
L15	VCCAUX	-		
L8	VCCAUX	-		
M15	VCCAUX	-		
M8	VCCAUX	-		
R11	VCCAUX	-		
R12	VCCAUX	-		
A1	GND	-		
A10	GND	-		
A16	GND	-		
A22	GND	-		
AA19	GND	-		
AA4	GND	-		
AB1	GND	-		
AB22	GND	-		
B13	GND	-		
B19	GND	-		
B4	GND	-		
D16	GND	-		
D2	GND	-		
D21	GND	-		
D7	GND	-		
G19	GND	-		
G4	GND	-		
H10	GND	-		
H13	GND	-		
J14	GND	-		
J9	GND	-		
K10	GND	-		
K11	GND	-		
K12	GND	-		
K13	GND	-		
K15	GND	-		
K20	GND	-		
K3	GND	-		
K8	GND	-		
L10	GND	-		

LFE2M50E/SE Logic Signal Connections: 484 fpBGA (Cont.)

LFE2M50E/SE				
Ball Number	Ball/Pad Function	Bank	Dual Function	Differential
L11	GND	-		
L12	GND	-		
L13	GND	-		
M10	GND	-		
M11	GND	-		
M12	GND	-		
M13	GND	-		
N10	GND	-		
N11	GND	-		
N12	GND	-		
N13	GND	-		
N15	GND	-		
N20	GND	-		
N3	GND	-		
N8	GND	-		
P14	GND	-		
P9	GND	-		
R10	GND	-		
R13	GND	-		
T19	GND	-		
T4	GND	-		
W16	GND	-		
W2	GND	-		
W21	GND	-		
W7	GND	-		
Y10	GND	-		
Y13	GND	-		
Y15	NC	-		
W15	NC	-		
AB20	NC	-		
AB21	NC	-		
AA21	NC	-		
AA20	NC	-		
AB19	NC	-		
AB18	NC	-		
Y22	NC	-		
Y21	NC	-		
Y17	NC	-		
Y18	NC	-		
Y16	NC	-		
W17	NC	-		
Y19	NC	-		
Y20	NC	-		

LFE2M50E/SE Logic Signal Connections: 484 fpBGA (Cont.)

LFE2M50E/SE				
Ball Number	Ball/Pad Function	Bank	Dual Function	Differential
W19	NC	-		
W18	NC	-		
V17	NC	-		
V18	NC	-		
D15	NC	-		
G14	NC	-		
G15	NC	-		
D14	NC	-		
E15	NC	-		
E14	NC	-		
F15	NC	-		
F14	NC	-		
F13	NC	-		
G12	NC	-		
G13	NC	-		
H8	VCCPLL	-		
H15	VCCPLL	-		
R8	VCCPLL	-		
R15	VCCPLL	-		

* Supports true LVDS. Other differential signals must be emulated with external resistors.

** These dedicated input pins can be used for GPLLs or GDLLs within the respective quadrant.

***For density migration, board design must take into account that these sysCONFIG pins are dual function for the lower density devices (ECP2M20 and ECP2M35) and are dedicated pins for the higher density devices (ECP2M50, ECP2M70 and ECP2M100).

****Due to packaging bond out option, this DQS does not have all the necessary DQ pins bonded out for a full 8-bit data width.

Note: VCCIO and GND pads are used to determine the average DC current drawn by I/Os between GND/VCCIO connections, or between the last GND/VCCIO in an I/O bank and the end of an I/O bank. The substrate pads listed in the Pin Table do not necessarily have a one to one connection with a package ball or pin.

LFE2M35E/SE and LFE2M50E/SE Logic Signal Connections: 672 fpBGA

LFE2M35E/SE					LFE2M50E/SE				
Ball Number	Ball/Pad Function	Bank	Dual Function	Differential	Ball/Pad Function	Bank	Dual Function	Differential	
C2	PL2A	7	LDQ6	T (LVDS)*	PL2A	7	LDQ6	T*	
C1	PL2B	7	LDQ6	C (LVDS)*	PL2B	7	LDQ6	C*	
F6	PL3A	7	LDQ6	T	PL3A	7	LDQ6	T	
H9	PL3B	7	LDQ6	C	PL3B	7	LDQ6	C	
D3	PL4A	7	LDQ6	T (LVDS)*	PL4A	7	LDQ6	T*	
VCCIO	VCCIO7	7			VCCIO7	7			
D2	PL4B	7	LDQ6	C (LVDS)*	PL4B	7	LDQ6	C*	
F5	PL5A	7	LDQ6	T	PL5A	7	LDQ6	T	
H8	PL5B	7	LDQ6	C	PL5B	7	LDQ6	C	
E3	PL6A	7	LDQS6	T (LVDS)*	PL6A	7	LDQS6	T*	
GNDIO	GNDIO7	-			GNDIO7	-			
E2	PL6B	7	LDQ6	C (LVDS)*	PL6B	7	LDQ6	C*	
J9	PL7A	7	LDQ6	T	PL7A	7	LDQ6	T	
E4	PL7B	7	LDQ6	C	PL7B	7	LDQ6	C	
VCCIO	VCCIO7	7			VCCIO7	7			
E1	PL8A	7	LDQ6	T (LVDS)*	PL8A	7	LDQ6	T*	
D1	PL8B	7	LDQ6	C (LVDS)*	PL8B	7	LDQ6	C*	
J8	PL9A	7	VREF2_7/LDQ6	T	PL9A	7	VREF2_7/LDQ6	T	
F4	PL9B	7	VREF1_7/LDQ6	C	PL9B	7	VREF1_7/LDQ6	C	
GNDIO	GNDIO7	-			GNDIO7	-			
-	-	-			VCCIO7	7			
F3	PL11A	7	LUM0_SPLLT_IN_A/LDQ15	T (LVDS)*	PL11A	7	LUM0_SPLLT_IN_A	T*	
F1	PL11B	7	LUM0_SPLLC_IN_A/LDQ15	C (LVDS)*	PL11B	7	LUM0_SPLLC_IN_A	C*	
G6	PL12A	7	LUM0_SPLLT_FB_A/LDQ15	T	PL12A	7	LUM0_SPLLT_FB_A	T	
K9	PL12B	7	LUM0_SPLLC_FB_A/LDQ15	C	PL12B	7	LUM0_SPLLC_FB_A	C	
-	-	-			GNDIO7	-			
G5	PL13A	7	LDQ15	T (LVDS)*	PL13A	7		T*	
VCCIO	VCCIO7	7			-	-			
G4	PL13B	7	LDQ15	C (LVDS)*	PL13B	7		C*	
H5	PL14A	7	LDQ15	T	PL14A	7		T	
-	-	-			VCCIO7	7			
H6	PL14B	7	LDQ15	C	PL14B	7		C	
GNDIO	GNDIO7	-			GNDIO7	-			
J7	PL16A	7	LDQ15	T	PL19A	7		T	
H4	PL16B	7	LDQ15	C	PL19B	7		C	
H3	PL17A	7	LDQ15	T (LVDS)*	PL20A	7		T*	
VCCIO	VCCIO7	7			VCCIO7	7			
G3	PL17B	7	LDQ15	C (LVDS)*	PL20B	7		C*	
GNDIO	GNDIO7	-			GNDIO7	-			
G1	PL19A	7	LDQ23	T (LVDS)*	PL23A	7	LDQ27	T*	
H1	PL19B	7	LDQ23	C (LVDS)*	PL23B	7	LDQ27	C*	
J3	PL20A	7	LDQ23	T	PL24A	7	LDQ27	T	
J4	PL20B	7	LDQ23	C	PL24B	7	LDQ27	C	
VCCIO	VCCIO7	7			VCCIO7	7			
H2	PL21A	7	LDQ23	T (LVDS)*	PL25A	7	LDQ27	T*	
J2	PL21B	7	LDQ23	C (LVDS)*	PL25B	7	LDQ27	C*	
K7	PL22A	7	LDQ23	T	PL26A	7	LDQ27	T	
J6	PL22B	7	LDQ23	C	PL26B	7	LDQ27	C	
GNDIO	GNDIO7	-			GNDIO7	-			

LFE2M35E/SE and LFE2M50E/SE Logic Signal Connections: 672 fpBGA

LFE2M35E/SE					LFE2M50E/SE				
Ball Number	Ball/Pad Function	Bank	Dual Function	Differential	Ball/Pad Function	Bank	Dual Function	Differential	
K5	PL23A	7	LDQS23	T (LVDS)*	PL27A	7	LDQS27	T*	
L5	PL23B	7	LDQ23	C (LVDS)*	PL27B	7	LDQ27	C*	
K4	PL24A	7	LDQ23	T	PL28A	7	LDQ27	T	
VCCIO	VCCIO7	7			VCCIO7	7			
L4	PL24B	7	LDQ23	C	PL28B	7	LDQ27	C	
K3	PL25A	7	LDQ23	T (LVDS)*	PL29A	7	LDQ27	T*	
L3	PL25B	7	LDQ23	C (LVDS)*	PL29B	7	LDQ27	C*	
J1	PL26A	7	LDQ23	T	PL30A	7	LDQ27	T	
GNDIO	GNDIO7	-			GNDIO7	-			
K2	PL26B	7	LDQ23	C	PL30B	7	LDQ27	C	
K1	PL28A	7	LUM1_SPLLT_IN_A/LDQ32	T (LVDS)*	PL32A	7	LUM3_SPLLT_IN_A/LDQ36	T*	
L1	PL28B	7	LUM1_SPLLC_IN_A/LDQ32	C (LVDS)*	PL32B	7	LUM3_SPLLC_IN_A/LDQ36	C*	
K8	PL29A	7	LUM1_SPLLT_FB_A/LDQ32	T	PL33A	7	LUM3_SPLLT_FB_A/LDQ36	T	
M5	PL29B	7	LUM1_SPLLC_FB_A/LDQ32	C	PL33B	7	LUM3_SPLLC_FB_A/LDQ36	C	
VCCIO	VCCIO7	7			VCCIO7	7			
M4	PL30A	7	LDQ32	T (LVDS)*	PL34A	7	LDQ36	T*	
M3	PL30B	7	LDQ32	C (LVDS)*	PL34B	7	LDQ36	C*	
L8	PL31A	7	LDQ32	T	PL35A	7	LDQ36	T	
M6	PL31B	7	LDQ32	C	PL35B	7	LDQ36	C	
GNDIO	GNDIO7	-			GNDIO7	-			
M1	PL32A	7	LDQS32	T (LVDS)*	PL36A	7	LDQS36	T*	
N1	PL32B	7	LDQ32	C (LVDS)*	PL36B	7	LDQ36	C*	
N3	PL33A	7	LDQ32	T	PL37A	7	LDQ36	T	
VCCIO	VCCIO7	7			VCCIO7	7			
N2	PL33B	7	LDQ32	C	PL37B	7	LDQ36	C	
N5	PL34A	7	LDQ32	T (LVDS)*	PL38A	7	LDQ36	T*	
N4	PL34B	7	LDQ32	C (LVDS)*	PL38B	7	LDQ36	C*	
M7	PL35A	7	PCLKT7_0/LDQ32	T	PL39A	7	PCLKT7_0/LDQ36	T	
GNDIO	GNDIO7	-			GNDIO7	-			
M8	PL35B	7	PCLKC7_0/LDQ32	C	PL39B	7	PCLKC7_0/LDQ36	C	
P3	PL37A	6	PCLKT6_0	T (LVDS)*	PL41A	6	PCLKT6_0	T*	
P2	PL37B	6	PCLKC6_0	C (LVDS)*	PL41B	6	PCLKC6_0	C*	
P5	PL38A	6	VREF2_6	T	PL42A	6	VREF2_6	T	
N6	PL38B	6	VREF1_6	C	PL42B	6	VREF1_6	C	
P4	PL39A	6		T (LVDS)*	PL43A	6		T*	
VCCIO	VCCIO6	6			VCCIO6	6			
R3	PL39B	6		C (LVDS)*	PL43B	6		C*	
P6	PL40A	6		T	PL44A	6		T	
N7	NC	-			PL44B	6		C	
P1	PL41A	6	LLM2_SPLLT_IN_A	T (LVDS)*	PL45A	6	LLM3_SPLLT_IN_A	T*	
GNDIO	GNDIO6	-			GNDIO6	-			
R1	PL41B	6	LLM2_SPLLC_IN_A	C (LVDS)*	PL45B	6	LLM3_SPLLC_IN_A	C*	
N8	PL42A	6	LLM2_SPLLT_FB_A	T	PL46A	6	LLM3_SPLLT_FB_A	T	
R5	PL42B	6	LLM2_SPLLC_FB_A	C	PL46B	6	LLM3_SPLLC_FB_A	C	
VCCIO	VCCIO6	6			VCCIO6	6			
T3	PL44A	6	LDQ48	T (LVDS)*	PL48A	6	LDQ52	T*	
T4	PL44B	6	LDQ48	C (LVDS)*	PL48B	6	LDQ52	C*	
P8	PL45A	6	LDQ48	T	PL49A	6	LDQ52	T	
R6	PL45B	6	LDQ48	C	PL49B	6	LDQ52	C	

LFE2M35E/SE and LFE2M50E/SE Logic Signal Connections: 672 fpBGA

LFE2M35E/SE					LFE2M50E/SE				
Ball Number	Ball/Pad Function	Bank	Dual Function	Differential	Ball/Pad Function	Bank	Dual Function	Differential	
VCCIO	VCCIO6	6			VCCIO6	6			
T1	PL46A	6	LDQ48	T (LVDS)*	PL50A	6	LDQ52	T*	
U1	PL46B	6	LDQ48	C (LVDS)*	PL50B	6	LDQ52	C*	
R7	PL47A	6	LDQ48	T	PL51A	6	LDQ52	T	
T5	PL47B	6	LDQ48	C	PL51B	6	LDQ52	C	
GNDIO	GNDIO6	-			GNDIO6	-			
U3	PL48A	6	LDQS48	T (LVDS)*	PL52A	6	LDQS52	T*	
U4	PL48B	6	LDQ48	C (LVDS)*	PL52B	6	LDQ52	C*	
U5	PL49A	6	LDQ48	T	PL53A	6	LDQ52	T	
VCCIO	VCCIO6	6			VCCIO6	6			
U6	PL49B	6	LDQ48	C	PL53B	6	LDQ52	C	
U2	PL50A	6	LDQ48	T (LVDS)*	PL54A	6	LDQ52	T*	
V1	PL50B	6	LDQ48	C (LVDS)*	PL54B	6	LDQ52	C*	
W2	PL51A	6	LDQ48	T	PL55A	6	LDQ52	T	
GNDIO	GNDIO6	-			GNDIO6	-			
V2	PL51B	6	LDQ48	C	PL55B	6	LDQ52	C	
V4	PL55A	6	LDQ57	T (LVDS)*	PL59A	6		T*	
VCCIO	VCCIO6	6			VCCIO6	6			
V3	PL55B	6	LDQ57	C (LVDS)*	PL59B	6		C*	
-	-	-			GNDIO6	-			
W4	PL57A	6	LLM0_GPLLT_IN_A**/LDQS57****	T (LVDS)*	PL62A	6	LLM0_GPLLT_IN_A	T*	
GNDIO	GNDIO6	-			GNDIO6	-			
W3	PL57B	6	LLM0_GPLLC_IN_A**/LDQ57	C (LVDS)*	PL62B	6	LLM0_GPLLC_IN_A	C*	
W1	PL58A	6	LLM0_GPLLT_FB_A/LDQ57	T	PL63A	6	LLM0_GPLLT_FB_A	T	
Y1	PL58B	6	LLM0_GPLLC_FB_A/LDQ57	C	PL63B	6	LLM0_GPLLC_FB_A	C	
VCCIO	VCCIO6	6			VCCIO6	6			
AA1	PL59A	6	LLM0_GDLLT_IN_A**/LDQ57	T (LVDS)*	PL64A	6	LLM0_GDLLT_IN_A	T*	
AB1	PL59B	6	LLM0_GDLLC_IN_A**/LDQ57	C (LVDS)*	PL64B	6	LLM0_GDLLC_IN_A	C*	
U7	PL60A	6	LLM0_GDLLT_FB_A/LDQ57	T	PL65A	6	LLM0_GDLLT_FB_A	T	
V6	PL60B	6	LLM0_GDLLC_FB_A/LDQ57	C	PL65B	6	LLM0_GDLLC_FB_A	C	
GNDIO	GNDIO6	-			GNDIO6	-			
T8	LLM0_PLLCAP	6			LLM0_PLLCAP	6			
W5	PL62A	6	LDQ66	T (LVDS)*	PL67A	6	LDQ71	T*	
Y4	PL62B	6	LDQ66	C (LVDS)*	PL67B	6	LDQ71	C*	
U8	PL63A	6	LDQ66	T	PL68A	6	LDQ71	T	
W6	PL63B	6	LDQ66	C	PL68B	6	LDQ71	C	
VCCIO	VCCIO6	6			VCCIO6	6			
Y3	PL64A	6	LDQ66	T (LVDS)*	PL69A	6	LDQ71	T*	
AA3	PL64B	6	LDQ66	C (LVDS)*	PL69B	6	LDQ71	C*	
V7	NC	-			PL70A	6	LDQ71	T	
Y5	PL65B	6	LDQ66	C	PL70B	6	LDQ71	C	
GNDIO	GNDIO6	-			GNDIO6	-			
AB2	PL66A	6	LDQS66	T (LVDS)*	PL71A	6	LDQS71	T*	
AA4	PL66B	6	LDQ66	C (LVDS)*	PL71B	6	LDQ71	C*	
Y6	PL67A	6	LDQ66	T	PL72A	6	LDQ71	T	
VCCIO	VCCIO6	6			VCCIO6	6			
U9	PL67B	6	LDQ66	C	PL72B	6	LDQ71	C	
AA5	PL68A	6	LDQ66	T (LVDS)*	PL73A	6	LDQ71	T*	
AA6	PL68B	6	LDQ66	C (LVDS)*	PL73B	6	LDQ71	C*	

LFE2M35E/SE and LFE2M50E/SE Logic Signal Connections: 672 fpBGA

LFE2M35E/SE					LFE2M50E/SE				
Ball Number	Ball/Pad Function	Bank	Dual Function	Differential	Ball/Pad Function	Bank	Dual Function	Differential	
Y7	PL69A	6	LDQ66	T	PL74A	6	LDQ71	T	
GNDIO	GNDIO6	-			GNDIO6	-			
V9	PL69B	6	LDQ66	C	PL74B	6	LDQ71	C	
AC3	TCK	-			TCK	-			
W8	TDI	-			TDI	-			
AC4	TMS	-			TMS	-			
V8	TDO	-			TDO	-			
AA7	VCCJ	-			VCCJ	-			
AB6	PB2A	5	BDQ6	T	PB2A	5	BDQ6	T	
Y8	PB2B	5	BDQ6	C	PB2B	5	BDQ6	C	
AD1	PB3A	5	BDQ6	T	PB3A	5	BDQ6	T	
AD2	PB3B	5	BDQ6	C	PB3B	5	BDQ6	C	
AC5	PB4A	5	BDQ6	T	PB4A	5	BDQ6	T	
AA8	PB4B	5	BDQ6	C	PB4B	5	BDQ6	C	
VCCIO	VCCIO5	5			VCCIO5	5			
AC6	PB5A	5	BDQ6	T	PB5A	5	BDQ6	T	
W9	PB5B	5	BDQ6	C	PB5B	5	BDQ6	C	
AB7	PB6A	5	BDQS6	T	PB6A	5	BDQS6	T	
GNDIO	GNDIO5	-			GNDIO5	-			
Y9	PB6B	5	BDQ6	C	PB6B	5	BDQ6	C	
AD3	PB7A	5	BDQ6	T	PB7A	5	BDQ6	T	
AD4	PB7B	5	BDQ6	C	PB7B	5	BDQ6	C	
AA9	PB8A	5	BDQ6	T	PB8A	5	BDQ6	T	
W10	PB8B	5	BDQ6	C	PB8B	5	BDQ6	C	
VCCIO	VCCIO5	5			VCCIO5	5			
AC7	PB9A	5	BDQ6	T	PB9A	5	BDQ6	T	
Y10	PB9B	5	BDQ6	C	PB9B	5	BDQ6	C	
AE2	PB10A	5	BDQ6	T	PB10A	5	BDQ6	T	
AD5	PB10B	5	BDQ6	C	PB10B	5	BDQ6	C	
GNDIO	GNDIO5	-			GNDIO5	-			
AE4	PB11A	5	BDQ15	T	PB11A	5	BDQ15	T	
AE3	PB11B	5	BDQ15	C	PB11B	5	BDQ15	C	
W11	PB12A	5	BDQ15	T	PB12A	5	BDQ15	T	
AB8	PB12B	5	BDQ15	C	PB12B	5	BDQ15	C	
AE5	PB13A	5	BDQ15	T	PB13A	5	BDQ15	T	
AD6	PB13B	5	BDQ15	C	PB13B	5	BDQ15	C	
VCCIO	VCCIO5	5			VCCIO5	5			
AA10	PB14A	5	BDQ15	T	PB14A	5	BDQ15	T	
AC8	PB14B	5	BDQ15	C	PB14B	5	BDQ15	C	
W12	PB15A	5	BDQS15	T	PB15A	5	BDQS15	T	
GNDIO	GNDIO5	-			GNDIO5	-			
AC9	PB15B	5	BDQ15	C	PB15B	5	BDQ15	C	
W13	PB16A	5	BDQ15	T	PB16A	5	BDQ15	T	
AB10	PB16B	5	BDQ15	C	PB16B	5	BDQ15	C	
AF3	PB17A	5	BDQ15	T	PB17A	5	BDQ15	T	
AF4	PB17B	5	BDQ15	C	PB17B	5	BDQ15	C	
VCCIO	VCCIO5	5			VCCIO5	5			
AF5	PB18A	5	BDQ15	T	PB18A	5	BDQ15	T	
AF6	PB18B	5	BDQ15	C	PB18B	5	BDQ15	C	

LFE2M35E/SE and LFE2M50E/SE Logic Signal Connections: 672 fpBGA

LFE2M35E/SE					LFE2M50E/SE				
Ball Number	Ball/Pad Function	Bank	Dual Function	Differential	Ball/Pad Function	Bank	Dual Function	Differential	
Y12	PB19A	5	BDQ15	T	PB19A	5	BDQ15	T	
GNDIO	GNDIO5	-			GNDIO5	-			
AB11	PB19B	5	BDQ15	C	PB19B	5	BDQ15	C	
-	-	-			VCCIO5	5			
-	-	-			GNDIO5	-			
AD7	PB20A	5	BDQ24	T	PB29A	5	BDQ33	T	
AF7	PB20B	5	BDQ24	C	PB29B	5	BDQ33	C	
AD8	PB21A	5	BDQ24	T	PB30A	5	BDQ33	T	
AA12	PB21B	5	BDQ24	C	PB30B	5	BDQ33	C	
AE8	PB22A	5	BDQ24	T	PB31A	5	BDQ33	T	
VCCIO	VCCIO5	5			VCCIO5	5			
AF8	PB22B	5	BDQ24	C	PB31B	5	BDQ33	C	
AD9	PB23A	5	BDQ24	T	PB32A	5	BDQ33	T	
AC10	PB23B	5	BDQ24	C	PB32B	5	BDQ33	C	
AC11	PB24A	5	BDQS24	T	PB33A	5	BDQS33	T	
GNDIO	GNDIO5	-			GNDIO5	-			
AB12	PB24B	5	BDQ24	C	PB33B	5	BDQ33	C	
AD10	PB25A	5	BDQ24	T	PB34A	5	BDQ33	T	
Y13	PB25B	5	BDQ24	C	PB34B	5	BDQ33	C	
AF9	PB26A	5	BDQ24	T	PB35A	5	BDQ33	T	
VCCIO	VCCIO5	5			VCCIO5	5			
AE9	PB26B	5	BDQ24	C	PB35B	5	BDQ33	C	
AF10	PB27A	5	BDQ24	T	PB36A	5	BDQ33	T	
AE10	PB27B	5	BDQ24	C	PB36B	5	BDQ33	C	
AD11	PB28A	5	BDQ24	T	PB37A	5	BDQ33	T	
GNDIO	GNDIO5	-			GNDIO5	-			
AF11	PB28B	5	BDQ24	C	PB37B	5	BDQ33	C	
VCCIO	VCCIO5	5			VCCIO5	5			
GNDIO	GNDIO5	-			GNDIO5	-			
AA13	PB33A	5	BDQS33****	T	PB42A	5	BDQS42****	T	
AB13	PB33B	5	BDQ33	C	PB42B	5	BDQ42	C	
W14	PB34A	5	VREF2_5/BDQ33	T	PB43A	5	VREF2_5/BDQ42	T	
AC12	PB34B	5	VREF1_5/BDQ33	C	PB43B	5	VREF1_5/BDQ42	C	
AF12	PB35A	5	PCLKT5_0/BDQ33	T	PB44A	5	PCLKT5_0/BDQ42	T	
AD12	PB35B	5	PCLKC5_0/BDQ33	C	PB44B	5	PCLKC5_0/BDQ42	C	
VCCIO	VCCIO5	5			VCCIO5	5			
GNDIO	GNDIO5	-			GNDIO5	-			
AC13	PB40A	4	PCLKT4_0/BDQ42	T	PB49A	4	PCLKT4_0/BDQ51	T	
VCCIO	VCCIO4	4			VCCIO4	4			
Y14	PB40B	4	PCLKC4_0/BDQ42	C	PB49B	4	PCLKC4_0/BDQ51	C	
AB20	PB57A	4	BDQ60	T	PB50A	4	VREF2_4/BDQ51	T	
AC14	PB41B	4	VREF1_4/BDQ42	C	PB50B	4	VREF1_4/BDQ51	C	
AB14	PB42A	4	BDQS42****	T	PB51A	4	BDQS51****	T	
GNDIO	GNDIO4	-			GNDIO4	-			
AA14	PB42B	4	BDQ42	C	PB51B	4	BDQ51	C	
VCCIO	VCCIO4	4			VCCIO4	4			
GNDIO	GNDIO4	-			GNDIO4	-			
W17	PB65A	4	BDQ69	T	PB56A	4	BDQ60	T	
AA19	PB65B	4	BDQ69	C	PB56B	4	BDQ60	C	

LFE2M35E/SE and LFE2M50E/SE Logic Signal Connections: 672 fpBGA

LFE2M35E/SE					LFE2M50E/SE				
Ball Number	Ball/Pad Function	Bank	Dual Function	Differential	Ball/Pad Function	Bank	Dual Function	Differential	
AC15	PB48A	4	BDQ51	T	PB57A	4	BDQ60	T	
Y18	PB68B	4	BDQ69	C	PB57B	4	BDQ60	C	
AB15	PB49A	4	BDQ51	T	PB58A	4	BDQ60	T	
AC16	PB49B	4	BDQ51	C	PB58B	4	BDQ60	C	
VCCIO	VCCIO4	4			VCCIO4	4			
AA17	PB60A	4	BDQS60****	T	PB59A	4	BDQ60	T	
AB16	PB50B	4	BDQ51	C	PB59B	4	BDQ60	C	
GNDIO	GNDIO4	-			GNDIO4	-			
AA15	PB51A	4	BDQS51****	T	PB60A	4	BDQS60	T	
W16	PB59B	4	BDQ60	C	PB60B	4	BDQ60	C	
Y15	PB52A	4	BDQ51	T	PB61A	4	BDQ60	T	
AC17	PB52B	4	BDQ51	C	PB61B	4	BDQ60	C	
AA18	PB61A	4	BDQ60	T	PB62A	4	BDQ60	T	
Y17	PB61B	4	BDQ60	C	PB62B	4	BDQ60	C	
-	-	-			VCCIO4	4			
GNDIO	GNDIO4	-			-	-			
W15	PB54A	4	BDQ51	T	PB63A	4	BDQ60	T	
AB17	PB54B	4	BDQ51	C	PB63B	4	BDQ60	C	
GNDIO	GNDIO4	-			GNDIO4	-			
VCCIO	VCCIO4	4			VCCIO4	4			
V17	PB73A	4	BDQ69	T	PB72A	4	BDQ69	T	
AA20	PB73B	4	BDQ69	C	PB72B	4	BDQ69	C	
GNDIO	GNDIO4	-			GNDIO4	-			
AD13	VCC	-			LRC_SQ_VCCRX3	13			
AF14	PB47A	4	BDQ51	T	LRC_SQ_HDINP3	13		T	
AE13	NC	-			LRC_SQ_VCCIB3	13			
AE14	PB41A	4	VREF2_4/BDQ42	T	LRC_SQ_HDINN3	13		C	
AD16	VCC	-			LRC_SQ_VCCTX3	13			
AF17	PB51B	4	BDQ51	C	LRC_SQ_HDOUPT3	13		T	
AF16	NC	-			LRC_SQ_VCCOB3	13			
AE17	PB50A	4	BDQ51	T	LRC_SQ_HDOUPT3	13		C	
AD17	VCC	-			LRC_SQ_VCCTX2	13			
AE18	PB53B	4	BDQ51	C	LRC_SQ_HDOUPT2	13		C	
AD18	NC	-			LRC_SQ_VCCOB2	13			
AF18	PB53A	4	BDQ51	T	LRC_SQ_HDOUPT2	13		T	
AD14	VCC	-			LRC_SQ_VCCRX2	13			
AE15	PB48B	4	BDQ51	C	LRC_SQ_HDINN2	13		C	
AD15	NC	-			LRC_SQ_VCCIB2	13			
AF15	PB47B	4	BDQ51	C	LRC_SQ_HDINP2	13		T	
AD19	VCC	-			LRC_SQ_VCCP	13			
AC19	PB57B	4	BDQ60	C	LRC_SQ_REFCLKP	13		T	
AB19	PB59A	4	BDQ60	T	LRC_SQ_REFCLKN	13		C	
AE19	VCCAUX	-			LRC_SQ_VCCAUX33	13			
AF23	PB64A	4	BDQ60	T	LRC_SQ_HDINP1	13		T	
AD23	NC	-			LRC_SQ_VCCIB1	13			
AE23	PB66B	4	BDQ69	C	LRC_SQ_HDINN1	13		C	
AD24	VCC	-			LRC_SQ_VCCRX1	13			
AF20	PB55A	4	BDQ51	T	LRC_SQ_HDOUPT1	13		T	
AD20	NC	-			LRC_SQ_VCCOB1	13			

LFE2M35E/SE and LFE2M50E/SE Logic Signal Connections: 672 fpBGA

LFE2M35E/SE					LFE2M50E/SE				
Ball Number	Ball/Pad Function	Bank	Dual Function	Differential	Ball/Pad Function	Bank	Dual Function	Differential	
AE20	PB55B	4	BDQ51	C	LRC_SQ_HDOUTN1	13		C	
AD21	VCC	-			LRC_SQ_VCCTX1	13			
AE21	PB63B	4	BDQ60	C	LRC_SQ_HDOUTN0	13		C	
AF22	NC	-			LRC_SQ_VCCOB0	13			
AF21	PB62A	4	BDQ60	T	LRC_SQ_HDOUTP0	13		T	
AD22	VCC	-			LRC_SQ_VCCTX0	13			
AE24	PB67B	4	BDQ69	C	LRC_SQ_HDINN0	13		C	
AE25	NC	-			LRC_SQ_VCCIB0	13			
AF24	PB67A	4	BDQ69	T	LRC_SQ_HDINP0	13		T	
AD25	VCC	-			LRC_SQ_VCCR0	13			
AA21	CFG2	8			CFG2	8			
AA22	CFG1	8			CFG1	8			
AB23	CFG0	8			CFG0	8			
AC26	PROGRAMN	8			PROGRAMN	8			
AB24	CCLK	8			CCLK	8			
AA23	INITN	8			INITN	8			
AB25	DONE	8			DONE	8			
GNDIO	GNDIO8	-			GNDIO8	-			
Y19	PR68B	8	WRITEN***	C	WRITEN***	8			
Y21	PR68A	8	CS1N***	T	CS1N***	8			
AB26	PR67B	8	CSN***	C	CSN***	8			
Y22	PR67A	8	D0/SPIFASTN***	T	D0/SPIFASTN***	8			
VCCIO	VCCIO8	8				8			
W19	PR66B	8	D1***	C	D1***	8			
Y20	PR66A	8	D2***	T	D2***	8			
W22	PR65B	8	D3***	C	D3***	8			
GNDIO	GNDIO8	-				-			
W18	PR65A	8	D4***	T	D4***	8			
Y23	PR64B	8	D5***	C	D5***	8			
AA24	PR64A	8	D6***	T	D6***	8			
W21	PR63B	8	D7***	C	D7***	8			
VCCIO	VCCIO8	8			VCCIO8	8			
V20	PR63A	8	DI/CSSPI0N***	T	DI/CSSPI0N***	8			
W23	PR62B	8	DOUT/CSON/CSSPI1N***	C	DOUT/CSON/ CSSPI1N***	8			
Y24	PR62A	8	BUSY/SISPI***	T	BUSY/SISPI***	8			
V19	RLM0_PLLCAP	3			RLM0_PLLCAP	3			
V21	PR60B	3	RLM0_GDLLC_FB_A	C	PR65B	3	RLM0_GDLLC_FB_A	C	
GNDIO	GNDIO3	-			GNDIO3	-			
U19	PR60A	3	RLM0_GDLLT_FB_A/RDQ57	T	PR65A	3	RLM0_GDLLT_FB_A	T	
AA26	PR59B	3	RLM0_GDLLC_IN_A**/RDQ57	C (LVDS)*	PR64B	3	RLM0_GDLLC_IN_A	C*	
Y26	PR59A	3	RLM0_GDLLT_IN_A**/RDQ57	T (LVDS)*	PR64A	3	RLM0_GDLLT_IN_A	T*	
V23	PR58B	3	RLM0_GPLLC_IN_A**/RDQ57	C	PR63B	3	RLM0_GPLLC_IN_A	C	
VCCIO	VCCIO3	3			VCCIO3	3			
U20	PR58A	3	RLM0_GPLLT_IN_A**/RDQ57	T	PR63A	3	RLM0_GPLLT_IN_A	T	
W24	PR57B	3	RLM0_GPLLC_FB_A/RDQ57	C (LVDS)*	PR62B	3	RLM0_GPLLC_FB_A	C*	
V24	PR57A	3	RLM0_GPLLT_FB_A/RDQ57	T (LVDS)*	PR62A	3	RLM0_GPLLT_FB_A	T*	
GNDIO	GNDIO3	-			GNDIO3	-			
U21	PR56A	3	RDQ57	T	PR60A	3		T	
W25	PR55B	3	RDQ57	C (LVDS)*	PR59B	3		C*	

LFE2M35E/SE and LFE2M50E/SE Logic Signal Connections: 672 fpBGA

LFE2M35E/SE					LFE2M50E/SE			
Ball Number	Ball/Pad Function	Bank	Dual Function	Differential	Ball/Pad Function	Bank	Dual Function	Differential
W26	PR55A	3	RDQ57	T (LVDS)*	PR59A	3		T*
VCCIO	VCCIO3	3			VCCIO3	3		
U18	PR54B	3	RDQ57	C	PR58B	3		C
U22	PR54A	3	RDQ57	T	PR58A	3		T
V25	PR53B	3	RDQ57	C (LVDS)*	PR57B	3		C*
V26	PR53A	3	RDQ57	T (LVDS)*	PR57A	3		T*
U24	PR51B	3	RDQ48	C	PR55B	3	RDQ52	C
T24	PR51A	3	RDQ48	T	PR55A	3	RDQ52	T
GNDIO	GNDIO3	-			GNDIO3	-		
T22	PR50B	3	RDQ48	C (LVDS)*	PR54B	3	RDQ52	C*
T23	PR50A	3	RDQ48	T (LVDS)*	PR54A	3	RDQ52	T*
U25	PR49B	3	RDQ48	C	PR53B	3	RDQ52	C
U26	PR49A	3	RDQ48	T	PR53A	3	RDQ52	T
VCCIO	VCCIO3	3			VCCIO3	3		
T19	PR48B	3	RDQ48	C (LVDS)*	PR52B	3	RDQ52	C*
R19	PR48A	3	RDQS48	T (LVDS)*	PR52A	3	RDQS52	T*
R21	PR47B	3	RDQ48	C	PR51B	3	RDQ52	C
GNDIO	GNDIO3	-			GNDIO3	-		
R20	PR47A	3	RDQ48	T	PR51A	3	RDQ52	T
T26	PR46B	3	RDQ48	C (LVDS)*	PR50B	3	RDQ52	C*
R26	PR46A	3	RDQ48	T (LVDS)*	PR50A	3	RDQ52	T*
P21	PR45B	3	RDQ48	C	PR49B	3	RDQ52	C
VCCIO	VCCIO3	3			VCCIO3	3		
P19	PR45A	3	RDQ48	T	PR49A	3	RDQ52	T
R23	PR44B	3	RDQ48	C (LVDS)*	PR48B	3	RDQ52	C*
R24	PR44A	3	RDQ48	T (LVDS)*	PR48A	3	RDQ52	T*
-	-	-			GNDIO3	-		
R22	PR42B	3	RLM2_SPLL_C_FB_A	C	PR46B	3	RLM3_SPLL_C_FB_A	C
VCCIO	VCCIO3	3			VCCIO3	3		
N19	PR42A	3	RLM2_SPLL_T_FB_A	T	PR46A	3	RLM3_SPLL_T_FB_A	T
P23	PR41B	3	RLM2_SPLL_C_IN_A	C (LVDS)*	PR45B	3	RLM3_SPLL_C_IN_A	C*
P24	PR41A	3	RLM2_SPLL_T_IN_A	T (LVDS)*	PR45A	3	RLM3_SPLL_T_IN_A	T*
GNDIO	GNDIO3	-			GNDIO3	-		
N21	PR40B	3		C	PR44B	3		C
P22	PR40A	3		T	PR44A	3		T
N20	PR39B	3		C (LVDS)*	PR43B	3		C*
N22	PR39A	3		T (LVDS)*	PR43A	3		T*
VCCIO	VCCIO3	3			VCCIO3	3		
P25	PR38B	3	VREF2_3	C	PR42B	3	VREF2_3	C
P26	PR38A	3	VREF1_3	T	PR42A	3	VREF1_3	T
M21	PR37B	3	PCLKC3_0	C (LVDS)*	PR41B	3	PCLKC3_0	C*
N23	PR37A	3	PCLKT3_0	T (LVDS)*	PR41A	3	PCLKT3_0	T*
N24	PR35B	2	PCLKC2_0/RDQ32	C	PR39B	2	PCLKC2_0/RDQ36	C
N25	PR35A	2	PCLKT2_0/RDQ32	T	PR39A	2	PCLKT2_0/RDQ36	T
GNDIO	GNDIO2	-			GNDIO2	-		
M22	PR34B	2	RDQ32	C (LVDS)*	PR38B	2	RDQ36	C*
M24	PR34A	2	RDQ32	T (LVDS)*	PR38A	2	RDQ36	T*
M23	PR33B	2	RDQ32	C	PR37B	2	RDQ36	C
N26	PR33A	2	RDQ32	T	PR37A	2	RDQ36	T

LFE2M35E/SE and LFE2M50E/SE Logic Signal Connections: 672 fpBGA

LFE2M35E/SE					LFE2M50E/SE			
Ball Number	Ball/Pad Function	Bank	Dual Function	Differential	Ball/Pad Function	Bank	Dual Function	Differential
VCCIO	VCCIO2	2			VCCIO2	2		
L22	PR32B	2	RDQ32	C (LVDS)*	PR36B	2	RDQ36	C*
L24	PR32A	2	RDQS32	T (LVDS)*	PR36A	2	RDQS36	T*
L23	PR31B	2	RDQ32	C	PR35B	2	RDQ36	C
GNDIO	GNDIO2	-			GNDIO2	-		
M20	PR31A	2	RDQ32	T	PR35A	2	RDQ36	T
M26	PR30B	2	RDQ32	C (LVDS)*	PR34B	2	RDQ36	C*
L26	PR30A	2	RDQ32	T (LVDS)*	PR34A	2	RDQ36	T*
K22	PR29B	2	RUM1_SPLLC_FB_A/RDQ32	C	PR33B	2	RUM3_SPLLC_FB_A/RDQ36	C
VCCIO	VCCIO2	2			VCCIO2	2		
M19	PR29A	2	RUM1_SPLLT_FB_A/RDQ32	T	PR33A	2	RUM3_SPLLT_FB_A/RDQ36	T
K25	PR28B	2	RUM1_SPLLC_IN_A/RDQ32	C (LVDS)*	PR32B	2	RUM3_SPLLC_IN_A/RDQ36	C*
K26	PR28A	2	RUM1_SPLLT_IN_A/RDQ32	T (LVDS)*	PR32A	2	RUM3_SPLLT_IN_A/RDQ36	T*
K24	PR26B	2	RDQ23	C	PR30B	2	RDQ27	C
K23	PR26A	2	RDQ23	T	PR30A	2	RDQ27	T
GNDIO	GNDIO2	-			GNDIO2	-		
L19	PR25B	2	RDQ23	C (LVDS)*	PR29B	2	RDQ27	C*
K21	PR25A	2	RDQ23	T (LVDS)*	PR29A	2	RDQ27	T*
J23	PR24B	2	RDQ23	C	PR28B	2	RDQ27	C
J24	PR24A	2	RDQ23	T	PR28A	2	RDQ27	T
VCCIO	VCCIO2	2			VCCIO2	2		
K20	PR23B	2	RDQ23	C (LVDS)*	PR27B	2	RDQ27	C*
J21	PR23A	2	RDQS23	T (LVDS)*	PR27A	2	RDQS27	T*
H21	PR22B	2	RDQ23	C	PR26B	2	RDQ27	C
GNDIO	GNDIO2	-			GNDIO2	-		
K18	PR22A	2	RDQ23	T	PR26A	2	RDQ27	T
H22	PR21B	2	RDQ23	C (LVDS)*	PR25B	2	RDQ27	C*
J20	PR21A	2	RDQ23	T (LVDS)*	PR25A	2	RDQ27	T*
J25	PR20B	2	RDQ23	C	PR24B	2	RDQ27	C
VCCIO	VCCIO2	2			VCCIO2	2		
J26	PR20A	2	RDQ23	T	PR24A	2	RDQ27	T
G21	PR19B	2	RDQ23	C (LVDS)*	PR23B	2	RDQ27	C*
J19	PR19A	2	RDQ23	T (LVDS)*	PR23A	2	RDQ27	T*
GNDIO	GNDIO2	-			GNDIO2	-		
H23	PR18B	2	RDQ15	C	PR21B	2		C
H24	PR18A	2	RDQ15	T	PR21A	2		T
H25	PR17B	2	RDQ15	C (LVDS)*	PR20B	2		C*
H26	PR17A	2	RDQ15	T (LVDS)*	PR20A	2		T*
VCCIO	VCCIO2	2			VCCIO2	2		
G22	PR16B	2	RDQ15	C	PR19B	2		C
K19	PR16A	2	RDQ15	T	PR19A	2		T
G24	PR15B	2	RDQ15	C (LVDS)*	PR18B	2		C*
G23	PR15A	2	RDQS15	T (LVDS)*	PR18A	2		T*
GNDIO	GNDIO2	-			GNDIO2	-		
J18	PR14B	2	RDQ15	C	PR14B	2		C
F22	PR14A	2	RDQ15	T	PR14A	2		T
-	-	-			VCCIO2	2		
F23	PR13B	2	RDQ15	C (LVDS)*	PR13B	2		C*
F24	PR13A	2	RDQ15	T (LVDS)*	PR13A	2		T*

LFE2M35E/SE and LFE2M50E/SE Logic Signal Connections: 672 fpBGA

LFE2M35E/SE					LFE2M50E/SE				
Ball Number	Ball/Pad Function	Bank	Dual Function	Differential	Ball/Pad Function	Bank	Dual Function	Differential	
VCCIO	VCCIO2	2			-	-			
H20	PR12B	2	RUM0_SPLLC_FB_A/RDQ15	C	PR12B	2	RUM0_SPLLC_FB_A	C	
-	-	-			GNDIO2	-			
F21	PR12A	2	RUM0_SPLLT_FB_A/RDQ15	T	PR12A	2	RUM0_SPLLT_FB_A	T	
G26	PR11B	2	RUM0_SPLLC_IN_A/RDQ15	C (LVDS)*	PR11B	2	RUM0_SPLLC_IN_A	C*	
F26	PR11A	2	RUM0_SPLLT_IN_A/RDQ15	T (LVDS)*	PR11A	2	RUM0_SPLLT_IN_A	T*	
-	-	-			VCCIO2	2			
E24	PR9B	2	VREF2_2	C	PR9B	2	VREF2_2	C	
GNDIO	GNDIO2	-			GNDIO2	-			
E23	PR9A	2	VREF1_2	T	PR9A	2	VREF1_2	T	
VCCIO	VCCIO4	4			VCCIO2	2			
H19	XRES	-			XRES	-			
C25	URC_SQ_VCCR _{X0}	12			URC_SQ_VCCR _{X0}	12			
A24	URC_SQ_HDIN _{P0}	12		T	URC_SQ_HDIN _{P0}	12		T	
B25	URC_SQ_VCCIB ₀	12			URC_SQ_VCCIB ₀	12			
B24	URC_SQ_HDINN ₀	12		C	URC_SQ_HDINN ₀	12		C	
C22	URC_SQ_VCCT _{X0}	12			URC_SQ_VCCT _{X0}	12			
A21	URC_SQ_HDOU _{T P0}	12		T	URC_SQ_HDOU _{T P0}	12		T	
A22	URC_SQ_VCCOB ₀	12			URC_SQ_VCCOB ₀	12			
B21	URC_SQ_HDOU _{T N0}	12		C	URC_SQ_HDOU _{T N0}	12		C	
C21	URC_SQ_VCCT _{X1}	12			URC_SQ_VCCT _{X1}	12			
B20	URC_SQ_HDOU _{T N1}	12		C	URC_SQ_HDOU _{T N1}	12		C	
C20	URC_SQ_VCCOB ₁	12			URC_SQ_VCCOB ₁	12			
A20	URC_SQ_HDOU _{T P1}	12		T	URC_SQ_HDOU _{T P1}	12		T	
C24	URC_SQ_VCCR _{X1}	12			URC_SQ_VCCR _{X1}	12			
B23	URC_SQ_HDINN ₁	12		C	URC_SQ_HDINN ₁	12		C	
C23	URC_SQ_VCCIB ₁	12			URC_SQ_VCCIB ₁	12			
A23	URC_SQ_HDIN _{P1}	12		T	URC_SQ_HDIN _{P1}	12		T	
B19	URC_SQ_VCCA _{UX33}	12			URC_SQ_VCCA _{UX33}	12			
E19	URC_SQ_REFCL _{KN}	12		C	URC_SQ_REFCL _{KN}	12		C	
D19	URC_SQ_REFCL _{KP}	12		T	URC_SQ_REFCL _{KP}	12		T	
C19	URC_SQ_VCCP	12			URC_SQ_VCCP	12			
A15	URC_SQ_HDIN _{P2}	12		T	URC_SQ_HDIN _{P2}	12		T	
C15	URC_SQ_VCCIB ₂	12			URC_SQ_VCCIB ₂	12			
B15	URC_SQ_HDINN ₂	12		C	URC_SQ_HDINN ₂	12		C	
C14	URC_SQ_VCCR _{X2}	12			URC_SQ_VCCR _{X2}	12			
A18	URC_SQ_HDOU _{T P2}	12		T	URC_SQ_HDOU _{T P2}	12		T	
C18	URC_SQ_VCCOB ₂	12			URC_SQ_VCCOB ₂	12			
B18	URC_SQ_HDOU _{T N2}	12		C	URC_SQ_HDOU _{T N2}	12		C	

LFE2M35E/SE and LFE2M50E/SE Logic Signal Connections: 672 fpBGA

LFE2M35E/SE					LFE2M50E/SE			
Ball Number	Ball/Pad Function	Bank	Dual Function	Differential	Ball/Pad Function	Bank	Dual Function	Differential
C17	URC_SQ_VCCTX2	12			URC_SQ_VCCTX2	12		
B17	URC_SQ_HDOU N3	12		C	URC_SQ_HDOU N3	12		C
A16	URC_SQ_VCCOB 3	12			URC_SQ_VCCOB3	12		
A17	URC_SQ_HDOU P3	12		T	URC_SQ_HDOU P3	12		T
C16	URC_SQ_VCCTX 3	12			URC_SQ_VCCTX3	12		
B14	URC_SQ_HDINN3	12		C	URC_SQ_HDINN3	12		C
B13	URC_SQ_VCCIB3	12			URC_SQ_VCCIB3	12		
A14	URC_SQ_HDINP3	12		T	URC_SQ_HDINP3	12		T
C13	URC_SQ_VCCRX 3	12			URC_SQ_VCCRX3	12		
-	-	-			GNDIO1	-		
-	-	-			VCCIO1	1		
E17	PT46B	1		C	PT55B	1		C
D17	PT46A	1		T	PT55A	1		T
GNDIO	GNDIO1	-			GNDIO1	-		
F17	PT45B	1		C	PT54B	1		C
D16	PT45A	1		T	PT54A	1		T
F19	PT44B	1		C	PT53B	1		C
F18	PT44A	1		T	PT53A	1		T
VCCIO	VCCIO1	1			VCCIO1	1		
E16	PT43B	1		C	PT52B	1		C
D15	PT43A	1		T	PT52A	1		T
G18	PT42B	1		C	PT51B	1		C
E15	PT42A	1		T	PT51A	1		T
GNDIO	GNDIO1	-			GNDIO1	-		
G17	PT41B	1		C	PT50B	1		C
E14	PT41A	1		T	PT50A	1		T
D14	PT40B	1		C	PT49B	1		C
D13	PT40A	1		T	PT49A	1		T
VCCIO	VCCIO1	1			VCCIO1	1		
F15	PT39B	1	VREF2_1	C	PT48B	1	VREF2_1	C
E12	PT39A	1	VREF1_1	T	PT48A	1	VREF1_1	T
H17	PT38B	1	PCLKC1_0	C	PT47B	1	PCLKC1_0	C
E13	PT38A	1	PCLKT1_0	T	PT47A	1	PCLKT1_0	T
C12	PT37B	0	PCLKC0_0	C	PT46B	0	PCLKC0_0	C
GNDIO	GNDIO0	-			GNDIO0	-		
G15	PT37A	0	PCLKT0_0	T	PT46A	0	PCLKT0_0	T
C11	PT36B	0	VREF2_0	C	PT45B	0	VREF2_0	C
F14	PT36A	0	VREF1_0	T	PT45A	0	VREF1_0	T
A12	PT35B	0		C	PT44B	0		C
VCCIO	VCCIO0	0			VCCIO0	0		
A11	PT35A	0		T	PT44A	0		T
D12	PT34B	0		C	PT43B	0		C
H16	PT34A	0		T	PT43A	0		T
H18	PT33B	0		C	PT42B	0		C
H15	PT33A	0		T	PT42A	0		T
A10	PT32B	0		C	PT41B	0		C

LFE2M35E/SE and LFE2M50E/SE Logic Signal Connections: 672 fpBGA

LFE2M35E/SE					LFE2M50E/SE			
Ball Number	Ball/Pad Function	Bank	Dual Function	Differential	Ball/Pad Function	Bank	Dual Function	Differential
GNDIO	GNDIO0	-			GNDIO0	-		
B10	PT32A	0		T	PT41A	0		T
D11	PT31B	0		C	PT40B	0		C
VCCIO	VCCIO0	0			VCCIO0	0		
G14	PT31A	0		T	PT40A	0		T
E11	PT30B	0		C	PT39B	0		C
F13	PT30A	0		T	PT39A	0		T
D10	PT29B	0		C	PT38B	0		C
H14	PT29A	0		T	PT38A	0		T
GNDIO	GNDIO0	-			GNDIO0	-		
VCCIO	VCCIO0	0			VCCIO0	0		
A9	PT24B	0		C	PT24B	0		C
C10	PT23B	0		C	PT23B	0		C
GNDIO	GNDIO0	-			GNDIO0	-		
E8	PT23A	0		T	PT23A	0		T
B9	PT22B	0		C	PT22B	0		C
A8	PT22A	0		T	PT22A	0		T
VCCIO	VCCIO0	0			VCCIO0	0		
F12	PT21B	0		C	PT21B	0		C
E10	PT21A	0		T	PT21A	0		T
G13	PT20B	0		C	PT20B	0		C
C9	PT20A	0		T	PT20A	0		T
B8	PT19B	0		C	PT19B	0		C
GNDIO	GNDIO0	-			GNDIO0	-		
A7	PT19A	0		T	PT19A	0		T
D9	PT18B	0		C	PT18B	0		C
H13	PT18A	0		T	PT18A	0		T
D6	PT17B	0		C	PT17B	0		C
C7	PT17A	0		T	PT17A	0		T
VCCIO	VCCIO0	0			VCCIO0	0		
C8	PT16B	0		C	PT16B	0		C
G12	PT16A	0		T	PT16A	0		T
D8	PT15B	0		C	PT15B	0		C
H12	PT15A	0		T	PT15A	0		T
GNDIO	GNDIO0	-			GNDIO0	-		
A6	PT14B	0		C	PT14B	0		C
A5	PT14A	0		T	PT14A	0		T
A4	PT13B	0		C	PT13B	0		C
A3	PT13A	0		T	PT13A	0		T
VCCIO	VCCIO0	0			VCCIO0	0		
C6	PT12B	0		C	PT12B	0		C
F10	PT12A	0		T	PT12A	0		T
D7	PT11B	0		C	PT11B	0		C
H11	PT11A	0		T	PT11A	0		T
D5	PT10B	0		C	PT10B	0		C
GNDIO	GNDIO0	-			GNDIO0	-		
E6	PT10A	0		T	PT10A	0		T
G10	PT9B	0		C	PT9B	0		C
F9	PT9A	0		T	PT9A	0		T

LFE2M35E/SE and LFE2M50E/SE Logic Signal Connections: 672 fpBGA

LFE2M35E/SE					LFE2M50E/SE			
Ball Number	Ball/Pad Function	Bank	Dual Function	Differential	Ball/Pad Function	Bank	Dual Function	Differential
H10	PT8B	0		C	PT8B	0		C
VCCIO	VCCIO0	0			VCCIO0	0		
E7	PT8A	0		T	PT8A	0		T
B3	PT7B	0		C	PT7B	0		C
C5	PT7A	0		T	PT7A	0		T
B2	PT6B	0		C	PT6B	0		C
C4	PT6A	0		T	PT6A	0		T
G9	PT5B	0		C	PT5B	0		C
GNDIO	GNDIO0	-			GNDIO0	-		
F7	PT5A	0		T	PT5A	0		T
C3	PT4B	0		C	PT4B	0		C
VCCIO	VCCIO0	0			VCCIO0	0		
D4	PT4A	0		T	PT4A	0		T
J10	PT3B	0		C	PT3B	0		C
F8	PT3A	0		T	PT3A	0		T
G8	PT2B	0		C	PT2B	0		C
G7	PT2A	0		T	PT2A	0		T
L12	VCC	-			VCC	-		
L13	VCC	-			VCC	-		
L14	VCC	-			VCC	-		
L15	VCC	-			VCC	-		
M11	VCC	-			VCC	-		
M12	VCC	-			VCC	-		
M15	VCC	-			VCC	-		
M16	VCC	-			VCC	-		
N11	VCC	-			VCC	-		
N16	VCC	-			VCC	-		
P11	VCC	-			VCC	-		
P16	VCC	-			VCC	-		
R11	VCC	-			VCC	-		
R12	VCC	-			VCC	-		
R15	VCC	-			VCC	-		
R16	VCC	-			VCC	-		
T12	VCC	-			VCC	-		
T13	VCC	-			VCC	-		
T14	VCC	-			VCC	-		
T15	VCC	-			VCC	-		
B12	VCCIO0	0			VCCIO0	0		
B7	VCCIO0	0			VCCIO0	0		
F11	VCCIO0	0			VCCIO0	0		
J13	VCCIO0	0			VCCIO0	0		
K12	VCCIO0	0			VCCIO0	1		
D18	VCCIO1	1			VCCIO1	1		
F16	VCCIO1	1			VCCIO1	1		
J14	VCCIO1	1			VCCIO1	1		
K15	VCCIO1	1			VCCIO1	1		
G25	VCCIO2	2			VCCIO2	2		
L21	VCCIO2	2			VCCIO2	2		
M17	VCCIO2	2			VCCIO2	2		

LFE2M35E/SE and LFE2M50E/SE Logic Signal Connections: 672 fpBGA

LFE2M35E/SE					LFE2M50E/SE			
Ball Number	Ball/Pad Function	Bank	Dual Function	Differential	Ball/Pad Function	Bank	Dual Function	Differential
M25	VCCIO2	2			VCCIO2	2		
N18	VCCIO2	2			VCCIO2	2		
P18	VCCIO3	3			VCCIO3	3		
R17	VCCIO3	3			VCCIO3	3		
R25	VCCIO3	3			VCCIO3	3		
T21	VCCIO3	3			VCCIO3	3		
Y25	VCCIO3	3			VCCIO3	3		
AA16	VCCIO4	4			VCCIO4	4		
AC18	VCCIO4	4			VCCIO4	4		
U15	VCCIO4	4			VCCIO4	4		
V14	VCCIO4	4			VCCIO4	4		
AA11	VCCIO5	5			VCCIO5	5		
V13	VCCIO5	5			VCCIO5	5		
AE12	VCCIO5	5			VCCIO5	5		
AE7	VCCIO5	5			VCCIO5	5		
U12	VCCIO5	5			VCCIO5	5		
P9	VCCIO6	6			VCCIO6	6		
R10	VCCIO6	6			VCCIO6	6		
R2	VCCIO6	6			VCCIO6	6		
T6	VCCIO6	6			VCCIO6	6		
Y2	VCCIO6	6			VCCIO6	6		
G2	VCCIO7	7			VCCIO7	7		
L6	VCCIO7	7			VCCIO7	7		
M10	VCCIO7	7			VCCIO7	7		
M2	VCCIO7	7			VCCIO7	7		
N9	VCCIO7	7			VCCIO7	7		
AC24	VCCIO8	8			VCCIO8	8		
U17	VCCIO8	8			VCCIO8	8		
J11	VCCAUX	-			VCCAUX	-		
J12	VCCAUX	-			VCCAUX	-		
J15	VCCAUX	-			VCCAUX	-		
J16	VCCAUX	-			VCCAUX	-		
L18	VCCAUX	-			VCCAUX	-		
L9	VCCAUX	-			VCCAUX	-		
M18	VCCAUX	-			VCCAUX	-		
M9	VCCAUX	-			VCCAUX	-		
R18	VCCAUX	-			VCCAUX	-		
R9	VCCAUX	-			VCCAUX	-		
T18	VCCAUX	-			VCCAUX	-		
T9	VCCAUX	-			VCCAUX	-		
V11	VCCAUX	-			VCCAUX	-		
V12	VCCAUX	-			VCCAUX	-		
V15	VCCAUX	-			VCCAUX	-		
V16	VCCAUX	-			VCCAUX	-		
A13	GND	-			GND	-		
A19	GND	-			GND	-		
A2	GND	-			GND	-		
A25	GND	-			GND	-		
AA2	GND	-			GND	-		

LFE2M35E/SE and LFE2M50E/SE Logic Signal Connections: 672 fpBGA

LFE2M35E/SE					LFE2M50E/SE			
Ball Number	Ball/Pad Function	Bank	Dual Function	Differential	Ball/Pad Function	Bank	Dual Function	Differential
AA25	GND	-			GND	-		
AB18	GND	-			GND	-		
AB22	GND	-			GND	-		
AB5	GND	-			GND	-		
AB9	GND	-			GND	-		
AE1	GND	-			GND	-		
AE11	GND	-			GND	-		
AE16	GND	-			GND	-		
AE22	GND	-			GND	-		
AE26	GND	-			GND	-		
AE6	GND	-			GND	-		
AF13	GND	-			GND	-		
AF19	GND	-			GND	-		
AF2	GND	-			GND	-		
AF25	GND	-			GND	-		
B1	GND	-			GND	-		
B11	GND	-			GND	-		
B16	GND	-			GND	-		
B22	GND	-			GND	-		
B26	GND	-			GND	-		
B6	GND	-			GND	-		
E18	GND	-			GND	-		
E22	GND	-			GND	-		
E5	GND	-			GND	-		
E9	GND	-			GND	-		
F2	GND	-			GND	-		
F25	GND	-			GND	-		
G11	GND	-			GND	-		
G16	GND	-			GND	-		
J22	GND	-			GND	-		
J5	GND	-			GND	-		
K11	GND	-			GND	-		
K13	GND	-			GND	-		
K14	GND	-			GND	-		
K16	GND	-			GND	-		
L10	GND	-			GND	-		
L11	GND	-			GND	-		
L16	GND	-			GND	-		
L17	GND	-			GND	-		
L2	GND	-			GND	-		
L20	GND	-			GND	-		
L25	GND	-			GND	-		
L7	GND	-			GND	-		
M13	GND	-			GND	-		
M14	GND	-			GND	-		
N10	GND	-			GND	-		
N12	GND	-			GND	-		
N13	GND	-			GND	-		
N14	GND	-			GND	-		

LFE2M35E/SE and LFE2M50E/SE Logic Signal Connections: 672 fpBGA

LFE2M35E/SE					LFE2M50E/SE			
Ball Number	Ball/Pad Function	Bank	Dual Function	Differential	Ball/Pad Function	Bank	Dual Function	Differential
N15	GND	-			GND	-		
N17	GND	-			GND	-		
P10	GND	-			GND	-		
P12	GND	-			GND	-		
P13	GND	-			GND	-		
P14	GND	-			GND	-		
P15	GND	-			GND	-		
P17	GND	-			GND	-		
R13	GND	-			GND	-		
R14	GND	-			GND	-		
T10	GND	-			GND	-		
T11	GND	-			GND	-		
T16	GND	-			GND	-		
T17	GND	-			GND	-		
T2	GND	-			GND	-		
T20	GND	-			GND	-		
T25	GND	-			GND	-		
T7	GND	-			GND	-		
U11	GND	-			GND	-		
U13	GND	-			GND	-		
U14	GND	-			GND	-		
U16	GND	-			GND	-		
V22	GND	-			GND	-		
V5	GND	-			GND	-		
Y11	GND	-			GND	-		
Y16	GND	-			GND	-		
AB3	NC	-			NC	-		
AB4	NC	-			NC	-		
AC1	NC	-			NC	-		
AC2	NC	-			NC	-		
B4	NC	-			NC	-		
B5	NC	-			NC	-		
C26	NC	-			NC	-		
D20	NC	-			NC	-		
D21	NC	-			NC	-		
D22	NC	-			NC	-		
D23	NC	-			NC	-		
D24	NC	-			NC	-		
D25	NC	-			NC	-		
D26	NC	-			NC	-		
E20	NC	-			NC	-		
E21	NC	-			NC	-		
E25	NC	-			NC	-		
E26	NC	-			NC	-		
F20	NC	-			NC	-		
G20	NC	-			NC	-		
K10	NC	-			NC	-		
K17	NC	-			NC	-		
R4	NC	-			NC	-		

LFE2M35E/SE and LFE2M50E/SE Logic Signal Connections: 672 fpBGA

LFE2M35E/SE					LFE2M50E/SE			
Ball Number	Ball/Pad Function	Bank	Dual Function	Differential	Ball/Pad Function	Bank	Dual Function	Differential
U10	NC	-			NC	-		
U23	NC	-			NC	-		
V10	NC	-			NC	-		
W7	NC	-			NC	-		
AB21	PB69B	4	BDQ69	C	NC	-		
AC20	PB58A	4	BDQ60	T	NC	-		
AC21	PB63A	4	BDQ60	T	NC	-		
AC22	PB69A	4	BDQS69****	T	NC	-		
AC23	PB71A	4	BDQ69	T	NC	-		
AC25	PB71B	4	BDQ69	C	NC	-		
AD26	PB70B	4	BDQ69	C	NC	-		
W20	PB72B	4	BDQ69	C	NC	-		
H7	L_VCCPLL	-			L_VCCPLL	-		
K6	L_VCCPLL	-			L_VCCPLL	-		
P7	L_VCCPLL	-			L_VCCPLL	-		
R8	L_VCCPLL	-			L_VCCPLL	-		
V18	R_VCCPLL	-			R_VCCPLL	-		
P20	R_VCCPLL	-			R_VCCPLL	-		
J17	R_VCCPLL	-			R_VCCPLL	-		
G19	R_VCCPLL	-			R_VCCPLL	-		

* Supports true LVDS. Other differential signals must be emulated with external resistors.

** These dedicated input pins can be used for GPLLs or GDLLs within the respective quadrant.

*** For density migration, board design must take into account that these sysCONFIG pins are dual function for the lower density devices (ECP2M20 and ECP2M35) and are dedicated pins for the higher density devices (ECP2M50, ECP2M70 and ECP2M100).

****Due to packaging bond out option, this DQS does not have all the necessary DQ pins bonded out for a full 8-bit data width.

Note: VCCIO and GND pads are used to determine the average DC current drawn by I/Os between GND/VCCIO connections, or between the last GND/VCCIO in an I/O bank and the end of an I/O bank. The substrate pads listed in the Pin Table do not necessarily have a one to one connection with a package ball or pin.

LFE2M50E/SE and LFE2M70E/SE Logic Signal Connections: 900 fpBGA

LFE2M50E/SE					LFE2M70E/SE			
Ball Number	Ball/Pad Function	Bank	Dual Function	Differential	Ball/Pad Function	Bank	Dual Function	Differential
VCCIO	VCCIO7	7			VCCIO7	7		
D2	PL9A	7	VREF2_7/LDQ6	T	PL9A	7	VREF2_7	T
D3	PL9B	7	VREF1_7/LDQ6	C	PL9B	7	VREF1_7	C
GNDIO	GNDIO7	-			GNDIO7	-		
J8	PL11A	7	LUM0_SPLLT_IN_A	T (LVDS)*	PL11A	7	LUM0_SPLLT_IN_A/LDQ15	T (LVDS)*
H7	PL11B	7	LUM0_SPLLC_IN_A	C (LVDS)*	PL11B	7	LUM0_SPLLC_IN_A/LDQ15	C (LVDS)*
E3	PL12A	7	LUM0_SPLLT_FB_A	T	PL12A	7	LUM0_SPLLT_FB_A/LDQ15	T
E4	PL12B	7	LUM0_SPLLC_FB_A	C	PL12B	7	LUM0_SPLLC_FB_A/LDQ15	C
GNDIO	GNDIO7	-			-	-		
-	-	-			VCCIO7	7		
G6	PL13A	7		T (LVDS)*	PL13A	7	LDQ15	T (LVDS)*
F5	PL13B	7		C (LVDS)*	PL13B	7	LDQ15	C (LVDS)*
E2	PL14A	7		T	PL14A	7	LDQ15	T
D1	PL14B	7		C	PL14B	7	LDQ15	C
-	-	-			GNDIO7	-		
G5	NC	-			PL15A	7	LDQS15	T (LVDS)*
G4	NC	-			PL15B	7	LDQ15	C (LVDS)*
K7	NC	-			PL16A	7	LDQ15	T
-	-	-			VCCIO7	7		
K8	NC	-			PL16B	7	LDQ15	C
E1	NC	-			PL17A	7	LDQ15	T (LVDS)*
F2	NC	-			PL17B	7	LDQ15	C (LVDS)*
F1	NC	-			PL18A	7	LDQ15	T
-	-	-			GNDIO7	-		
G3	NC	-			PL18B	7	LDQ15	C
-	-	-			-	-		
VCCIO	VCCIO7	7			VCCIO7	7		
H5	PL15A	7		T (LVDS)*	PL21A	7		T (LVDS)*
H4	PL15B	7		C (LVDS)*	PL21B	7		C (LVDS)*
J5	PL16A	7		T	PL22A	7		T
J4	PL16B	7		C	PL22B	7		C
GNDIO	GNDIO7	-			GNDIO7	-		
G2	NC	-			PL24A	7	LDQ28	T (LVDS)*
G1	NC	-			PL24B	7	LDQ28	C (LVDS)*
L9	NC	-			PL25A	7	LDQ28	T
L7	NC	-			PL25B	7	LDQ28	C
-	-	-			VCCIO7	7		
K6	NC	-			PL26A	7	LDQ28	T (LVDS)*
K5	NC	-			PL26B	7	LDQ28	C (LVDS)*
L8	NC	-			PL27A	7	LDQ28	T
L6	NC	-			PL27B	7	LDQ28	C
-	-	-			GNDIO7	-		
H3	PL18A	7		T (LVDS)*	PL28A	7	LDQS28	T (LVDS)*
H2	PL18B	7		C (LVDS)*	PL28B	7	LDQ28	C (LVDS)*
N8	PL19A	7		T	PL29A	7	LDQ28	T
-	-	-			VCCIO7	7		
M9	PL19B	7		C	PL29B	7	LDQ28	C
J3	PL20A	7		T (LVDS)*	PL30A	7	LDQ28	T (LVDS)*
VCCIO	VCCIO7	7			-	-		

LFE2M50E/SE and LFE2M70E/SE Logic Signal Connections: 900 fpBGA

LFE2M50E/SE					LFE2M70E/SE				
Ball Number	Ball/Pad Function	Bank	Dual Function	Differential	Ball/Pad Function	Bank	Dual Function	Differential	
J2	PL20B	7		C (LVDS)*	PL30B	7	LDQ28	C (LVDS)*	
H1	PL21A	7		T	PL31A	7	LDQ28	T	
GNDIO	GNDIO7	-			GNDIO7	-			
J1	PL21B	7		C	PL31B	7	LDQ28	C	
-	-	-			-	-			
-	-	-			-	-			
L5	PL23A	7	LDQ27	T (LVDS)*	PL33A	7	LDQ37	T (LVDS)*	
L4	PL23B	7	LDQ27	C (LVDS)*	PL33B	7	LDQ37	C (LVDS)*	
N9	PL24A	7	LDQ27	T	PL34A	7	LDQ37	T	
N7	PL24B	7	LDQ27	C	PL34B	7	LDQ37	C	
VCCIO	VCCIO7	7			VCCIO7	7			
K2	PL25A	7	LDQ27	T (LVDS)*	PL35A	7	LDQ37	T (LVDS)*	
K1	PL25B	7	LDQ27	C (LVDS)*	PL35B	7	LDQ37	C (LVDS)*	
P9	PL26A	7	LDQ27	T	PL36A	7	LDQ37	T	
P7	PL26B	7	LDQ27	C	PL36B	7	LDQ37	C	
GNDIO	GNDIO7	-			GNDIO7	-			
M6	PL27A	7	LDQS27	T (LVDS)*	PL37A	7	LDQS37	T (LVDS)*	
M5	PL27B	7	LDQ27	C (LVDS)*	PL37B	7	LDQ37	C (LVDS)*	
N5	PL28A	7	LDQ27	T	PL38A	7	LDQ37	T	
VCCIO	VCCIO7	7			VCCIO7	7			
N6	PL28B	7	LDQ27	C	PL38B	7	LDQ37	C	
M4	PL29A	7	LDQ27	T (LVDS)*	PL39A	7	LDQ37	T (LVDS)*	
M3	PL29B	7	LDQ27	C (LVDS)*	PL39B	7	LDQ37	C (LVDS)*	
P6	PL30A	7	LDQ27	T	PL40A	7	LDQ37	T	
GNDIO	GNDIO7	-			GNDIO7	-			
P8	PL30B	7	LDQ27	C	PL40B	7	LDQ37	C	
L3	PL32A	7	LUM3_SPLLT_IN_A/LDQ36	T (LVDS)*	PL42A	7	LUM3_SPLLT_IN_A/LDQ46	T (LVDS)*	
L2	PL32B	7	LUM3_SPLLC_IN_A/LDQ36	C (LVDS)*	PL42B	7	LUM3_SPLLC_IN_A/LDQ46	C (LVDS)*	
P5	PL33A	7	LUM3_SPLLT_FB_A/LDQ36	T	PL43A	7	LUM3_SPLLT_FB_A/LDQ46	T	
P4	PL33B	7	LUM3_SPLLC_FB_A/LDQ36	C	PL43B	7	LUM3_SPLLC_FB_A/LDQ46	C	
VCCIO	VCCIO7	7			VCCIO7	7			
L1	PL34A	7	LDQ36	T (LVDS)*	PL44A	7	LDQ46	T (LVDS)*	
M2	PL34B	7	LDQ36	C (LVDS)*	PL44B	7	LDQ46	C (LVDS)*	
R5	PL35A	7	LDQ36	T	PL45A	7	LDQ46	T	
R4	PL35B	7	LDQ36	C	PL45B	7	LDQ46	C	
GNDIO	GNDIO7	-			GNDIO7	-			
M1	PL36A	7	LDQS36	T (LVDS)*	PL46A	7	LDQS46	T (LVDS)*	
N2	PL36B	7	LDQ36	C (LVDS)*	PL46B	7	LDQ46	C (LVDS)*	
R8	PL37A	7	LDQ36	T	PL47A	7	LDQ46	T	
VCCIO	VCCIO7	7			VCCIO7	7			
T9	PL37B	7	LDQ36	C	PL47B	7	LDQ46	C	
P3	PL38A	7	LDQ36	T (LVDS)*	PL48A	7	LDQ46	T (LVDS)*	
P2	PL38B	7	LDQ36	C (LVDS)*	PL48B	7	LDQ46	C (LVDS)*	
N1	PL39A	7	PCLKT7_0/LDQ36	T	PL49A	7	PCLKT7_0/LDQ46	T	
GNDIO	GNDIO7	-			GNDIO7	-			
P1	PL39B	7	PCLKC7_0/LDQ36	C	PL49B	7	PCLKC7_0/LDQ46	C	
T5	PL41A	6	PCLKT6_0	T (LVDS)*	PL51A	6	PCLKT6_0/LDQ55	T (LVDS)*	
T4	PL41B	6	PCLKC6_0	C (LVDS)*	PL51B	6	PCLKC6_0/LDQ55	C (LVDS)*	
U7	PL42A	6	VREF2_6	T	PL52A	6	VREF2_6/LDQ55	T	

LFE2M50E/SE and LFE2M70E/SE Logic Signal Connections: 900 fpBGA

LFE2M50E/SE					LFE2M70E/SE			
Ball Number	Ball/Pad Function	Bank	Dual Function	Differential	Ball/Pad Function	Bank	Dual Function	Differential
T8	PL42B	6	VREF1_6	C	PL52B	6	VREF1_6/LDQ55	C
R3	PL43A	6		T (LVDS)*	PL53A	6	LDQ55	T (LVDS)*
VCCIO	VCCIO6	6			VCCIO6	6		
R2	PL43B	6		C (LVDS)*	PL53B	6	LDQ55	C (LVDS)*
R1	PL44A	6		T	PL54A	6	LDQ55	T
T1	PL44B	6		C	PL54B	6	LDQ55	C
GNDIO	GNDIO6	-			GNDIO6	-		
-	-	-			VCCIO6	6		
T3	PL45A	6	LLM3_SPLLT_IN_A	T (LVDS)*	PL57A	6	LLM3_SPLLT_IN_A/LDQ55	T (LVDS)*
T2	PL45B	6	LLM3_SPLLC_IN_A	C (LVDS)*	PL57B	6	LLM3_SPLLC_IN_A/LDQ55	C (LVDS)*
U9	PL46A	6	LLM3_SPLLT_FB_A	T	PL58A	6	LLM3_SPLLT_FB_A/LDQ55	T
U8	PL46B	6	LLM3_SPLLC_FB_A	C	PL58B	6	LLM3_SPLLC_FB_A/LDQ55	C
VCCIO	VCCIO6	6			GNDIO6	-		
U5	PL48A	6	LDQ52	T (LVDS)*	PL60A	6	LDQ64	T (LVDS)*
U4	PL48B	6	LDQ52	C (LVDS)*	PL60B	6	LDQ64	C (LVDS)*
V9	PL49A	6	LDQ52	T	PL61A	6	LDQ64	T
V7	PL49B	6	LDQ52	C	PL61B	6	LDQ64	C
VCCIO	VCCIO6	6			VCCIO6	6		
U3	PL50A	6	LDQ52	T (LVDS)*	PL62A	6	LDQ64	T (LVDS)*
U2	PL50B	6	LDQ52	C (LVDS)*	PL62B	6	LDQ64	C (LVDS)*
V8	PL51A	6	LDQ52	T	PL63A	6	LDQ64	T
U6	PL51B	6	LDQ52	C	PL63B	6	LDQ64	C
GNDIO	GNDIO6	-			GNDIO6	-		
U1	PL52A	6	LDQS52	T (LVDS)*	PL64A	6	LDQS64	T (LVDS)*
V2	PL52B	6	LDQ52	C (LVDS)*	PL64B	6	LDQ64	C (LVDS)*
V5	PL53A	6	LDQ52	T	PL65A	6	LDQ64	T
VCCIO	VCCIO6	6			VCCIO6	6		
V6	PL53B	6	LDQ52	C	PL65B	6	LDQ64	C
V1	PL54A	6	LDQ52	T (LVDS)*	PL66A	6	LDQ64	T (LVDS)*
W1	PL54B	6	LDQ52	C (LVDS)*	PL66B	6	LDQ64	C (LVDS)*
W5	PL55A	6	LDQ52	T	PL67A	6	LDQ64	T
GNDIO	GNDIO6	-			GNDIO6	-		
W6	PL55B	6	LDQ52	C	PL67B	6	LDQ64	C
W3	PL57A	6		T (LVDS)*	PL69A	6	LDQ73	T (LVDS)*
W4	PL57B	6		C (LVDS)*	PL69B	6	LDQ73	C (LVDS)*
W2	PL58A	6		T	PL70A	6	LDQ73	T
Y4	PL58B	6		C	PL70B	6	LDQ73	C
Y1	PL59A	6		T (LVDS)*	PL71A	6	LDQ73	T (LVDS)*
VCCIO	VCCIO6	6			VCCIO6	6		
Y2	PL59B	6		C (LVDS)*	PL71B	6	LDQ73	C (LVDS)*
Y5	PL60A	6		T	PL72A	6	LDQ73	T
Y6	PL60B	6		C	PL72B	6	LDQ73	C
AA1	NC	-			PL73A	6	LDQS73	T (LVDS)*
GNDIO	GNDIO6	-			GNDIO6	-		
AA2	NC	-			PL73B	6	LDQ73	C (LVDS)*
Y3	NC	-			PL74A	6	LDQ73	T
AB1	NC	-			PL74B	6	LDQ73	C
-	-	-			VCCIO6	6		
Y9	NC	-			PL75A	6	LDQ73	T (LVDS)*

LFE2M50E/SE and LFE2M70E/SE Logic Signal Connections: 900 fpBGA

LFE2M50E/SE					LFE2M70E/SE			
Ball Number	Ball/Pad Function	Bank	Dual Function	Differential	Ball/Pad Function	Bank	Dual Function	Differential
Y8	NC	-			PL75B	6	LDQ73	C (LVDS)*
Y7	NC	-			PL76A	6	LDQ73	T
AA7	NC	-			PL76B	6	LDQ73	C
-	-	-			GNDIO6	-		
-	-	-			-	-		
AB2	NC	-			PL78A	6	LDQ82	T (LVDS)*
AB3	NC	-			PL78B	6	LDQ82	C (LVDS)*
AA5	NC	-			PL79A	6	LDQ82	T
AA6	NC	-			PL79B	6	LDQ82	C
AB4	NC	-			PL80A	6	LDQ82	T (LVDS)*
-	-	-			VCCIO6	6		
AB5	NC	-			PL80B	6	LDQ82	C (LVDS)*
AA8	NC	-			PL81A	6	LDQ82	T
AA9	NC	-			PL81B	6	LDQ82	C
AC1	PL62A	6	LLM0_GPLLT_IN_A**	T (LVDS)*	PL82A	6	LLM0_GPLLT_IN_A**/LDQS82	T (LVDS)*
GNDIO	GNDIO6	-			GNDIO6	-		
AC2	PL62B	6	LLM0_GPLLC_IN_A**	C (LVDS)*	PL82B	6	LLM0_GPLLC_IN_A**/LDQ82	C (LVDS)*
AC4	PL63A	6	LLM0_GPLLT_FB_A	T	PL83A	6	LLM0_GPLLT_FB_A/LDQ82	T
AC3	PL63B	6	LLM0_GPLLC_FB_A	C	PL83B	6	LLM0_GPLLC_FB_A/LDQ82	C
VCCIO	VCCIO6	6			VCCIO6	6		
AC7	PL64A	6	LLM0_GDLLT_IN_A**	T (LVDS)*	PL84A	6	LLM0_GDLLT_IN_A**/LDQ82	T (LVDS)*
AC6	PL64B	6	LLM0_GDLLC_IN_A**	C (LVDS)*	PL84B	6	LLM0_GDLLC_IN_A**/LDQ82	C (LVDS)*
AC5	PL65A	6	LLM0_GDLLT_FB_A	T	PL85A	6	LLM0_GDLLT_FB_A/LDQ82	T
AD3	PL65B	6	LLM0_GDLLC_FB_A	C	PL85B	6	LLM0_GDLLC_FB_A/LDQ82	C
GNDIO	GNDIO6	-			GNDIO6	-		
AB8	LLM0_PLLCAP	6			LLM0_PLLCAP	6		
AD2	PL67A	6	LDQ71	T (LVDS)*	PL87A	6		T
AD1	PL67B	6	LDQ71	C (LVDS)*	PL87B	6		C
AE2	TCK	-			TCK	-		
AE1	TDI	-			TDI	-		
AF2	TMS	-			TMS	-		
AF1	TDO	-			TDO	-		
AG1	VCCJ	-			VCCJ	-		
AH1	VCC	-			LLC_SQ_VCCR3	14		
AK2	PB11A	5	BDQ15	T	LLC_SQ_HDINP3	14		T
AJ1	NC	-			LLC_SQ_VCCIB3	14		
AJ2	PB11B	5	BDQ15	C	LLC_SQ_HDINN3	14		C
AH4	VCC	-			LLC_SQ_VCCTX3	14		
AK5	PB13A	5	BDQ15	T	LLC_SQ_HDOU3P3	14		T
AK4	NC	-			LLC_SQ_VCCOB3	14		
AJ5	PB13B	5	BDQ15	C	LLC_SQ_HDOU3N3	14		C
AH5	VCC	-			LLC_SQ_VCCTX2	14		
AJ6	PB14B	5	BDQ15	C	LLC_SQ_HDOU2N2	14		C
AH6	NC	-			LLC_SQ_VCCOB2	14		
AK6	PB14A	5	BDQ15	T	LLC_SQ_HDOU2P2	14		T
AH2	VCC	-			LLC_SQ_VCCR2	14		
AJ3	PB12B	5	BDQ15	C	LLC_SQ_HDINN2	14		C
AH3	NC	-			LLC_SQ_VCCIB2	14		
AK3	PB12A	5	BDQ15	T	LLC_SQ_HDINP2	14		T

LFE2M50E/SE and LFE2M70E/SE Logic Signal Connections: 900 fpBGA

LFE2M50E/SE					LFE2M70E/SE				
Ball Number	Ball/Pad Function	Bank	Dual Function	Differential	Ball/Pad Function	Bank	Dual Function	Differential	
AH7	VCC	-			LLC_SQ_VCCP	14			
AG7	PB15A	5	BDQS15	T	LLC_SQ_REFCLKP	14		T	
AF7	PB15B	5	BDQ15	C	LLC_SQ_REFCLKN	14		C	
AJ7	VCCAUX	-			LLC_SQ_VCCAUX33	14			
AK11	PB18A	5	BDQ15	T	LLC_SQ_HDINP1	14		T	
AH11	NC	-			LLC_SQ_VCCIB1	14			
AJ11	PB18B	5	BDQ15	C	LLC_SQ_HDINN1	14		C	
AH12	VCC	-			LLC_SQ_VCCRX1	14			
AK8	PB16A	5	BDQ15	T	LLC_SQ_HDOUTP1	14		T	
AH8	NC	-			LLC_SQ_VCCOB1	14			
AJ8	PB16B	5	BDQ15	C	LLC_SQ_HDOUTN1	14		C	
AH9	VCC	-			LLC_SQ_VCCTX1	14			
AJ9	PB17B	5	BDQ15	C	LLC_SQ_HDOUTN0	14		C	
AK10	NC	-			LLC_SQ_VCCOB0	14			
AK9	PB17A	5	BDQ15	T	LLC_SQ_HDOUTP0	14		T	
AH10	VCC	-			LLC_SQ_VCCTX0	14			
AJ12	PB19B	5	BDQ15	C	LLC_SQ_HDINN0	14		C	
AJ13	NC	-			LLC_SQ_VCCIB0	14			
AK12	PB19A	5	BDQ15	T	LLC_SQ_HDINP0	14		T	
AH13	VCC	-			LLC_SQ_VCCRX0	14			
AF10	PB3A	5	BDQ6	T	PB30A	5	BDQ33	T	
AE8	PB3B	5	BDQ6	C	PB30B	5	BDQ33	C	
AE11	PB4A	5	BDQ6	T	PB31A	5	BDQ33	T	
VCCIO	VCCIO5	5			VCCIO5	5			
AD9	PB4B	5	BDQ6	C	PB31B	5	BDQ33	C	
AE10	PB5A	5	BDQ6	T	PB32A	5	BDQ33	T	
AD10	PB5B	5	BDQ6	C	PB32B	5	BDQ33	C	
AE13	PB6A	5	BDQS6	T	PB33A	5	BDQS33	T	
GNDIO	GNDIO5	-			GNDIO5	-			
AC12	PB6B	5	BDQ6	C	PB33B	5	BDQ33	C	
AG2	PB7A	5	BDQ6	T	PB34A	5	BDQ33	T	
AG3	PB7B	5	BDQ6	C	PB34B	5	BDQ33	C	
AD13	PB8A	5	BDQ6	T	PB35A	5	BDQ33	T	
VCCIO	VCCIO5	5			VCCIO5	5			
AC13	PB8B	5	BDQ6	C	PB35B	5	BDQ33	C	
AE14	PB9A	5	BDQ6	T	PB36A	5	BDQ33	T	
AC14	PB9B	5	BDQ6	C	PB36B	5	BDQ33	C	
AF3	PB10A	5	BDQ6	T	PB37A	5	BDQ33	T	
GNDIO	GNDIO5	-			GNDIO5	-			
AF4	PB10B	5	BDQ6	C	PB37B	5	BDQ33	C	
VCCIO	VCCIO5	5			-	-			
AG4	PB20A	5	BDQ24	T	PB38A	5	BDQ42	T	
AG5	PB20B	5	BDQ24	C	PB38B	5	BDQ42	C	
GNDIO	GNDIO5	-			-	-			
VCCIO	VCCIO5	5			-	-			
AD11	PB24A	5	BDQS24****	T	PB39A	5	BDQ42	T	
AF13	PB24B	5	BDQ24	C	PB39B	5	BDQ42	C	
AF12	PB25A	5	BDQ24	T	PB40A	5	BDQ42	T	
-	-	-			VCCIO5	5			

LFE2M50E/SE and LFE2M70E/SE Logic Signal Connections: 900 fpBGA

LFE2M50E/SE					LFE2M70E/SE			
Ball Number	Ball/Pad Function	Bank	Dual Function	Differential	Ball/Pad Function	Bank	Dual Function	Differential
AD14	PB25B	5	BDQ24	C	PB40B	5	BDQ42	C
AG8	PB26A	5	BDQ24	T	PB41A	5	BDQ42	T
AF8	PB26B	5	BDQ24	C	PB41B	5	BDQ42	C
AE15	PB27A	5	BDQ24	T	PB42A	5	BDQS42****	T
-	-	-			GNDIO5	-		
VCCIO	VCCIO5	5			-	-		
AC15	PB27B	5	BDQ24	C	PB42B	5	BDQ42	C
VCCIO	VCCIO5	5			VCCIO5	5		
GNDIO	GNDIO5	-			GNDIO5	-		
AD15	PB38A	5	BDQ42	T	PB47A	5	BDQ51	T
AF15	PB38B	5	BDQ42	C	PB47B	5	BDQ51	C
AG10	PB39A	5	BDQ42	T	PB48A	5	BDQ51	T
AG9	PB39B	5	BDQ42	C	PB48B	5	BDQ51	C
AH14	PB40A	5	BDQ42	T	PB49A	5	BDQ51	T
AG12	PB40B	5	BDQ42	C	PB49B	5	BDQ51	C
VCCIO	VCCIO5	5			VCCIO5	5		
AG15	PB41A	5	BDQ42	T	PB50A	5	BDQ51	T
AG13	PB41B	5	BDQ42	C	PB50B	5	BDQ51	C
GNDIO	GNDIO5	-			GNDIO5	-		
AF16	PB42A	5	BDQS42	T	PB51A	5	BDQS51	T
AH15	PB42B	5	BDQ42	C	PB51B	5	BDQ51	C
AC16	PB43A	5	VREF2_5/BDQ42	T	PB52A	5	VREF2_5/BDQ51	T
AE16	PB43B	5	VREF1_5/BDQ42	C	PB52B	5	VREF1_5/BDQ51	C
AG11	PB44A	5	PCLKT5_0/BDQ42	T	PB53A	5	PCLKT5_0/BDQ51	T
AF11	PB44B	5	PCLKC5_0/BDQ42	C	PB53B	5	PCLKC5_0/BDQ51	C
VCCIO	VCCIO5	5			VCCIO5	5		
GNDIO	GNDIO5	-			GNDIO5	-		
AJ14	PB49A	4	PCLKT4_0/BDQ51	T	PB58A	4	PCLKT4_0/BDQ60	T
VCCIO	VCCIO4	4			VCCIO4	4		
AK14	PB49B	4	PCLKC4_0/BDQ51	C	PB58B	4	PCLKC4_0/BDQ60	C
AK15	PB50A	4	VREF2_4/BDQ51	T	PB59A	4	VREF2_4/BDQ60	T
AK16	PB50B	4	VREF1_4/BDQ51	C	PB59B	4	VREF1_4/BDQ60	C
AF18	PB51A	4	BDQS51	T	PB60A	4	BDQS60	T
GNDIO	GNDIO4	-			GNDIO4	-		
AD16	PB51B	4	BDQ51	C	PB60B	4	BDQ60	C
AJ15	PB52A	4	BDQ51	T	PB61A	4	BDQ60	T
AG16	PB52B	4	BDQ51	C	PB61B	4	BDQ60	C
AE17	PB53A	4	BDQ51	T	PB62A	4	BDQ60	T
VCCIO	VCCIO4	4			VCCIO4	4		
AC17	PB53B	4	BDQ51	C	PB62B	4	BDQ60	C
AH16	PB54A	4	BDQ51	T	PB63A	4	BDQ60	T
AK17	PB54B	4	BDQ51	C	PB63B	4	BDQ60	C
AG20	PB55A	4	BDQ51	T	PB64A	4	BDQ60	T
GNDIO	GNDIO4	-			GNDIO4	-		
AG21	PB55B	4	BDQ51	C	PB64B	4	BDQ60	C
AG18	PB56A	4	BDQ60	T	PB65A	4	BDQ69	T
AJ16	PB56B	4	BDQ60	C	PB65B	4	BDQ69	C
AF21	PB57A	4	BDQ60	T	PB66A	4	BDQ69	T
AG22	PB57B	4	BDQ60	C	PB66B	4	BDQ69	C

LFE2M50E/SE and LFE2M70E/SE Logic Signal Connections: 900 fpBGA

LFE2M50E/SE					LFE2M70E/SE				
Ball Number	Ball/Pad Function	Bank	Dual Function	Differential	Ball/Pad Function	Bank	Dual Function	Differential	
AD17	PB58A	4	BDQ60	T	PB67A	4	BDQ69	T	
AF19	PB58B	4	BDQ60	C	PB67B	4	BDQ69	C	
VCCIO	VCCIO4	4			VCCIO4	4			
GNDIO	GNDIO4	-			GNDIO4	-			
AH17	PB62A	4	BDQ60	T	PB71A	4	BDQ69	T	
AJ17	PB62B	4	BDQ60	C	PB71B	4	BDQ69	C	
VCCIO	VCCIO4	4			VCCIO4	4			
AF26	PB64A	4	BDQ60	T	PB73A	4	BDQ69	T	
AE25	PB64B	4	BDQ60	C	PB73B	4	BDQ69	C	
GNDIO	GNDIO4	-			GNDIO4	-			
AD24	PB65A	4	BDQ69	T	PB74A	4	BDQ78	T	
AE24	PB65B	4	BDQ69	C	PB74B	4	BDQ78	C	
AD18	PB66A	4	BDQ69	T	PB75A	4	BDQ78	T	
AC18	PB66B	4	BDQ69	C	PB75B	4	BDQ78	C	
AE18	PB67A	4	BDQ69	T	PB76A	4	BDQ78	T	
AG19	PB67B	4	BDQ69	C	PB76B	4	BDQ78	C	
VCCIO	VCCIO4	4			VCCIO4	4			
GNDIO	GNDIO4	-			GNDIO4	-			
AC19	PB69A	4	BDQS69	T	PB78A	4	BDQS78	T	
AD20	PB69B	4	BDQ69	C	PB78B	4	BDQ78	C	
AB18	PB70A	4	BDQ69	T	PB79A	4	BDQ78	T	
AC20	PB70B	4	BDQ69	C	PB79B	4	BDQ78	C	
AE20	PB71A	4	BDQ69	T	PB80A	4	BDQ78	T	
AE21	PB71B	4	BDQ69	C	PB80B	4	BDQ78	C	
VCCIO	VCCIO4	4			VCCIO4	4			
AC23	PB72A	4	BDQ69	T	PB81A	4	BDQ78	T	
AD23	PB72B	4	BDQ69	C	PB81B	4	BDQ78	C	
GNDIO	GNDIO4	-			GNDIO4	-			
AH18	LRC_SQ_VCCR3	13			LRC_SQ_VCCR3	13			
AK19	LRC_SQ_HDINP3	13		T	LRC_SQ_HDINP3	13		T	
AJ18	LRC_SQ_VCCIB3	13			LRC_SQ_VCCIB3	13			
AJ19	LRC_SQ_HDINN3	13		C	LRC_SQ_HDINN3	13		C	
AH21	LRC_SQ_VCCTX3	13			LRC_SQ_VCCTX3	13			
AK22	LRC_SQ_HDOU3	13		T	LRC_SQ_HDOU3	13		T	
AK21	LRC_SQ_VCCOB3	13			LRC_SQ_VCCOB3	13			
AJ22	LRC_SQ_HDOU3N3	13		C	LRC_SQ_HDOU3N3	13		C	
AH22	LRC_SQ_VCCTX2	13			LRC_SQ_VCCTX2	13			
AJ23	LRC_SQ_HDOU2N2	13		C	LRC_SQ_HDOU2N2	13		C	
AH23	LRC_SQ_VCCOB2	13			LRC_SQ_VCCOB2	13			
AK23	LRC_SQ_HDOU2	13		T	LRC_SQ_HDOU2	13		T	
AH19	LRC_SQ_VCCR2	13			LRC_SQ_VCCR2	13			
AJ20	LRC_SQ_HDINN2	13		C	LRC_SQ_HDINN2	13		C	
AH20	LRC_SQ_VCCIB2	13			LRC_SQ_VCCIB2	13			
AK20	LRC_SQ_HDINP2	13		T	LRC_SQ_HDINP2	13		T	
AH24	LRC_SQ_VCCP	13			LRC_SQ_VCCP	13			
AG24	LRC_SQ_REFCLKP	13		T	LRC_SQ_REFCLKP	13		T	
AF24	LRC_SQ_REFCLKN	13		C	LRC_SQ_REFCLKN	13		C	
AJ24	LRC_SQ_VCCAUX33	13			LRC_SQ_VCCAUX33	13			
AK28	LRC_SQ_HDINP1	13		T	LRC_SQ_HDINP1	13		T	

LFE2M50E/SE and LFE2M70E/SE Logic Signal Connections: 900 fpBGA

LFE2M50E/SE					LFE2M70E/SE			
Ball Number	Ball/Pad Function	Bank	Dual Function	Differential	Ball/Pad Function	Bank	Dual Function	Differential
AH28	LRC_SQ_VCCIB1	13			LRC_SQ_VCCIB1	13		
AJ28	LRC_SQ_HDINN1	13		C	LRC_SQ_HDINN1	13		C
AH29	LRC_SQ_VCCRX1	13			LRC_SQ_VCCRX1	13		
AK25	LRC_SQ_HDOUPT1	13		T	LRC_SQ_HDOUPT1	13		T
AH25	LRC_SQ_VCCOB1	13			LRC_SQ_VCCOB1	13		
AJ25	LRC_SQ_HDOUPTN1	13		C	LRC_SQ_HDOUPTN1	13		C
AH26	LRC_SQ_VCCTX1	13			LRC_SQ_VCCTX1	13		
AJ26	LRC_SQ_HDOUPTN0	13		C	LRC_SQ_HDOUPTN0	13		C
AK27	LRC_SQ_VCCOB0	13			LRC_SQ_VCCOB0	13		
AK26	LRC_SQ_HDOUPT0	13		T	LRC_SQ_HDOUPT0	13		T
AH27	LRC_SQ_VCCTX0	13			LRC_SQ_VCCTX0	13		
AJ29	LRC_SQ_HDINN0	13		C	LRC_SQ_HDINN0	13		C
AJ30	LRC_SQ_VCCIB0	13			LRC_SQ_VCCIB0	13		
AK29	LRC_SQ_HDINP0	13		T	LRC_SQ_HDINP0	13		T
AH30	LRC_SQ_VCCRX0	13			LRC_SQ_VCCRX0	13		
AG27	CFG2	8			CFG2	8		
AD25	CFG1	8			CFG1	8		
AG28	CFG0	8			CFG0	8		
AG30	PROGRAMN	8			PROGRAMN	8		
AG29	CCLK	8			CCLK	8		
AC24	INITN	8			INITN	8		
AF27	DONE	8			DONE	8		
GNDIO	GNDIO8	-			GNDIO8	-		
AF28	WRITEN***	8			WRITEN***	8		
AE26	CS1N***	8			CS1N***	8		
AB23	CSN***	8			CSN***	8		
AF29	D0/SPIFASTN***	8			D0/SPIFASTN***	8		
VCCIO	VCCIO8	8			VCCIO8	8		
AF30	D1***	8			D1***	8		
AD26	D2***	8			D2***	8		
AE29	D3***	8			D3***	8		
GNDIO	GNDIO8	-			GNDIO8	-		
AE30	D4***	8			D4***	8		
AD29	D5***	8			D5***	8		
AC25	D6***	8			D6***	8		
AD30	D7***	8			D7***	8		
VCCIO	VCCIO8	8			VCCIO8	8		
AA22	DI/CSSPI0N***	8			DI/CSSPI0N***	8		
AC26	DOUT/CSON/ CSSPI1N***	8			DOUT/CSON/ CSSPI1N***	8		
AA23	BUSY/SISPI***	8			BUSY/SISPI***	8		
AB22	RLM0_PLLCAP	3			RLM0_PLLCAP	3		
AC27	PR65B	3	RLM0_GDLLC_FB_A	C	PR85B	3	RLM0_GDLLC_FB_A/RDQ82	C
GNDIO	GNDIO3	-			GNDIO3	-		
AC28	PR65A	3	RLM0_GDLLT_FB_A	T	PR85A	3	RLM0_GDLLT_FB_A/RDQ82	T
AC29	PR64B	3	RLM0_GDLLC_IN_A**	C (LVDS)*	PR84B	3	RLM0_GDLLC_IN_A**/RDQ82	C (LVDS)*
AC30	PR64A	3	RLM0_GDLLT_IN_A**	T (LVDS)*	PR84A	3	RLM0_GDLLT_IN_A**/RDQ82	T (LVDS)*
AB30	PR63B	3	RLM0_GPLL_C_IN_A**	C	PR83B	3	RLM0_GPLL_C_IN_A**/RDQ82	C
VCCIO	VCCIO3	3			VCCIO3	3		
AA30	PR63A	3	RLM0_GPLLT_IN_A**	T	PR83A	3	RLM0_GPLLT_IN_A**/RDQ82	T

LFE2M50E/SE and LFE2M70E/SE Logic Signal Connections: 900 fpBGA

LFE2M50E/SE					LFE2M70E/SE			
Ball Number	Ball/Pad Function	Bank	Dual Function	Differential	Ball/Pad Function	Bank	Dual Function	Differential
AB29	PR62B	3	RLM0_GPLL_C_FB_A	C (LVDS)*	PR82B	3	RLM0_GPLL_C_FB_A/RDQ82	C (LVDS)*
AB28	PR62A	3	RLM0_GPLL_T_FB_A	T (LVDS)*	PR82A	3	RLM0_GPLL_T_FB_A/RDQS82	T (LVDS)*
GNDIO	GNDIO3	-			GNDIO3	-		
Y22	PR60B	3		C	PR81B	3	RDQ82	C
Y23	PR60A	3		T	PR81A	3	RDQ82	T
AB26	NC	-			PR80B	3	RDQ82	C (LVDS)*
AB27	NC	-			PR80A	3	RDQ82	T (LVDS)*
-	-	-			VCCIO3	3		
Y24	NC	-			PR79B	3	RDQ82	C
Y25	NC	-			PR79A	3	RDQ82	T
AA29	NC	-			PR78B	3	RDQ82	C (LVDS)*
Y28	NC	-			PR78A	3	RDQ82	T (LVDS)*
Y30	NC	-			PR76B	3	RDQ73	C
Y29	NC	-			PR76A	3	RDQ73	T
-	-	-			GNDIO3	-		
-	-	-			-	-		
W22	NC	-			PR75B	3	RDQ73	C (LVDS)*
V22	NC	-			PR75A	3	RDQ73	T (LVDS)*
Y27	NC	-			PR74B	3	RDQ73	C
-	-	-			VCCIO3	3		
Y26	NC	-			PR74A	3	RDQ73	T
W30	NC	-			PR73B	3	RDQ73	C (LVDS)*
W29	NC	-			PR73A	3	RDQS73	T (LVDS)*
-	-	-			GNDIO3	-		
W25	NC	-			PR72B	3	RDQ73	C
W26	NC	-			PR72A	3	RDQ73	T
U29	PR59B	3		C (LVDS)*	PR71B	3	RDQ73	C (LVDS)*
V29	PR59A	3		T (LVDS)*	PR71A	3	RDQ73	T (LVDS)*
VCCIO	VCCIO3	3			VCCIO3	3		
V30	PR58B	3		C	PR70B	3	RDQ73	C
U30	PR58A	3		T	PR70A	3	RDQ73	T
W27	PR57B	3		C (LVDS)*	PR69B	3	RDQ73	C (LVDS)*
W28	PR57A	3		T (LVDS)*	PR69A	3	RDQ73	T (LVDS)*
V24	PR55B	3	RDQ52	C	PR67B	3	RDQ64	C
V25	PR55A	3	RDQ52	T	PR67A	3	RDQ64	T
GNDIO	GNDIO3	-			GNDIO3	-		
U28	PR54B	3	RDQ52	C (LVDS)*	PR66B	3	RDQ64	C (LVDS)*
U27	PR54A	3	RDQ52	T (LVDS)*	PR66A	3	RDQ64	T (LVDS)*
U23	PR53B	3	RDQ52	C	PR65B	3	RDQ64	C
V23	PR53A	3	RDQ52	T	PR65A	3	RDQ64	T
VCCIO	VCCIO3	3			VCCIO3	3		
V26	PR52B	3	RDQ52	C (LVDS)*	PR64B	3	RDQ64	C (LVDS)*
U26	PR52A	3	RDQS52	T (LVDS)*	PR64A	3	RDQS64	T (LVDS)*
U25	PR51B	3	RDQ52	C	PR63B	3	RDQ64	C
GNDIO	GNDIO3	-			GNDIO3	-		
U24	PR51A	3	RDQ52	T	PR63A	3	RDQ64	T
T30	PR50B	3	RDQ52	C (LVDS)*	PR62B	3	RDQ64	C (LVDS)*
R30	PR50A	3	RDQ52	T (LVDS)*	PR62A	3	RDQ64	T (LVDS)*
T23	PR49B	3	RDQ52	C	PR61B	3	RDQ64	C

LFE2M50E/SE and LFE2M70E/SE Logic Signal Connections: 900 fpBGA

LFE2M50E/SE					LFE2M70E/SE			
Ball Number	Ball/Pad Function	Bank	Dual Function	Differential	Ball/Pad Function	Bank	Dual Function	Differential
VCCIO	VCCIO3	3			VCCIO3	3		
T22	PR49A	3	RDQ52	T	PR61A	3	RDQ64	T
T29	PR48B	3	RDQ52	C (LVDS)*	PR60B	3	RDQ64	C (LVDS)*
T28	PR48A	3	RDQ52	T (LVDS)*	PR60A	3	RDQ64	T (LVDS)*
R23	PR46B	3	RLM3_SPLLC_FB_A	C	PR58B	3	RLM3_SPLLC_FB_A/RDQ55	C
GNDIO	GNDIO3	-			GNDIO3	-		
VCCIO	VCCIO3	3			-	-		
R22	PR46A	3	RLM3_SPLLT_FB_A	T	PR58A	3	RLM3_SPLLT_FB_A/RDQ55	T
P30	PR45B	3	RLM3_SPLLC_IN_A	C (LVDS)*	PR57B	3	RLM3_SPLLC_IN_A/RDQ55	C (LVDS)*
R29	PR45A	3	RLM3_SPLLT_IN_A	T (LVDS)*	PR57A	3	RLM3_SPLLT_IN_A/RDQ55	T (LVDS)*
T27	PR44B	3		C	PR56B	3	RDQ55	C
-	-	-			VCCIO3	3		
T26	PR44A	3		T	PR56A	3	RDQ55	T
GNDIO	GNDIO3	-			GNDIO3	-		
N30	PR43B	3		C (LVDS)*	PR53B	3	RDQ55	C (LVDS)*
N29	PR43A	3		T (LVDS)*	PR53A	3	RDQ55	T (LVDS)*
VCCIO	VCCIO3	3			VCCIO3	3		
R27	PR42B	3	VREF2_3	C	PR52B	3	VREF2_3/RDQ55	C
R28	PR42A	3	VREF1_3	T	PR52A	3	VREF1_3/RDQ55	T
P29	PR41B	3	PCLKC3_0	C (LVDS)*	PR51B	3	PCLKC3_0/RDQ55	C (LVDS)*
P28	PR41A	3	PCLKT3_0	T (LVDS)*	PR51A	3	PCLKT3_0/RDQ55	T (LVDS)*
M30	PR39B	2	PCLKC2_0/RDQ36	C	PR49B	2	PCLKC2_0/RDQ46	C
M29	PR39A	2	PCLKT2_0/RDQ36	T	PR49A	2	PCLKT2_0/RDQ46	T
GNDIO	GNDIO2	-			GNDIO2	-		
P23	PR38B	2	RDQ36	C (LVDS)*	PR48B	2	RDQ46	C (LVDS)*
P24	PR38A	2	RDQ36	T (LVDS)*	PR48A	2	RDQ46	T (LVDS)*
R26	PR37B	2	RDQ36	C	PR47B	2	RDQ46	C
P27	PR37A	2	RDQ36	T	PR47A	2	RDQ46	T
VCCIO	VCCIO2	2			VCCIO2	2		
P25	PR36B	2	RDQ36	C (LVDS)*	PR46B	2	RDQ46	C (LVDS)*
P26	PR36A	2	RDQS36	T (LVDS)*	PR46A	2	RDQS46	T (LVDS)*
K30	PR35B	2	RDQ36	C	PR45B	2	RDQ46	C
GNDIO	GNDIO2	-			GNDIO2	-		
K29	PR35A	2	RDQ36	T	PR45A	2	RDQ46	T
N22	PR34B	2	RDQ36	C (LVDS)*	PR44B	2	RDQ46	C (LVDS)*
P22	PR34A	2	RDQ36	T (LVDS)*	PR44A	2	RDQ46	T (LVDS)*
J30	PR33B	2	RUM3_SPLLC_FB_A/RDQ36	C	PR43B	2	RUM3_SPLLC_FB_A/RDQ46	C
VCCIO	VCCIO2	2			VCCIO2	2		
J29	PR33A	2	RUM3_SPLLT_FB_A/RDQ36	T	PR43A	2	RUM3_SPLLT_FB_A/RDQ46	T
N24	PR32B	2	RUM3_SPLLC_IN_A/RDQ36	C (LVDS)*	PR42B	2	RUM3_SPLLC_IN_A/RDQ46	C (LVDS)*
N23	PR32A	2	RUM3_SPLLT_IN_A/RDQ36	T (LVDS)*	PR42A	2	RUM3_SPLLT_IN_A/RDQ46	T (LVDS)*
N25	PR30B	2	RDQ27	C	PR40B	2	RDQ37	C
N26	PR30A	2	RDQ27	T	PR40A	2	RDQ37	T
GNDIO	GNDIO2	-			GNDIO2	-		
M27	PR29B	2	RDQ27	C (LVDS)*	PR39B	2	RDQ37	C (LVDS)*
M28	PR29A	2	RDQ27	T (LVDS)*	PR39A	2	RDQ37	T (LVDS)*
H30	PR28B	2	RDQ27	C	PR38B	2	RDQ37	C
G30	PR28A	2	RDQ27	T	PR38A	2	RDQ37	T
VCCIO	VCCIO2	2			VCCIO2	2		

LFE2M50E/SE and LFE2M70E/SE Logic Signal Connections: 900 fpBGA

LFE2M50E/SE					LFE2M70E/SE				
Ball Number	Ball/Pad Function	Bank	Dual Function	Differential	Ball/Pad Function	Bank	Dual Function	Differential	
M25	PR27B	2	RDQ27	C (LVDS)*	PR37B	2	RDQ37	C (LVDS)*	
M26	PR27A	2	RDQS27	T (LVDS)*	PR37A	2	RDQS37	T (LVDS)*	
L30	PR26B	2	RDQ27	C	PR36B	2	RDQ37	C	
GNDIO	GNDIO2	-			GNDIO2	-			
L29	PR26A	2	RDQ27	T	PR36A	2	RDQ37	T	
L28	PR25B	2	RDQ27	C (LVDS)*	PR35B	2	RDQ37	C (LVDS)*	
L27	PR25A	2	RDQ27	T (LVDS)*	PR35A	2	RDQ37	T (LVDS)*	
H29	PR24B	2	RDQ27	C	PR34B	2	RDQ37	C	
VCCIO	VCCIO2	2			VCCIO2	2			
G29	PR24A	2	RDQ27	T	PR34A	2	RDQ37	T	
L22	PR23B	2	RDQ27	C (LVDS)*	PR33B	2	RDQ37	C (LVDS)*	
M22	PR23A	2	RDQ27	T (LVDS)*	PR33A	2	RDQ37	T (LVDS)*	
F30	PR21B	2		C	PR31B	2	RDQ28	C	
GNDIO	GNDIO2	-			GNDIO2	-			
F29	PR21A	2		T	PR31A	2	RDQ28	T	
-	-	-			-	-			
-	-	-			-	-			
E30	PR20B	2		C (LVDS)*	PR30B	2	RDQ28	C (LVDS)*	
E29	PR20A	2		T (LVDS)*	PR30A	2	RDQ28	T (LVDS)*	
VCCIO	VCCIO2	2			-	-			
L25	PR19B	2		C	PR29B	2	RDQ28	C	
L26	PR19A	2		T	PR29A	2	RDQ28	T	
-	-	-			VCCIO2	2			
H28	PR18B	2		C (LVDS)*	PR28B	2	RDQ28	C (LVDS)*	
J28	PR18A	2		T (LVDS)*	PR28A	2	RDQS28	T (LVDS)*	
G28	PR16B	2		C	PR27B	2	RDQ28	C	
GNDIO	GNDIO2	-			GNDIO2	-			
G27	PR16A	2		T	PR27A	2	RDQ28	T	
L24	NC	-			PR26B	2	RDQ28	C (LVDS)*	
L23	NC	-			PR26A	2	RDQ28	T (LVDS)*	
D30	NC	-			PR25B	2	RDQ28	C	
-	-	-			VCCIO2	2			
D29	NC	-			PR25A	2	RDQ28	T	
K24	NC	-			PR24B	2	RDQ28	C (LVDS)*	
K25	NC	-			PR24A	2	RDQ28	T (LVDS)*	
J27	NC	-			PR22B	2		C	
-	-	-			GNDIO2	-			
K26	NC	-			PR22A	2		T	
K23	PR15B	2		C (LVDS)*	PR21B	2		C (LVDS)*	
K22	PR15A	2		T (LVDS)*	PR21A	2		T (LVDS)*	
J22	PR14B	2		C	PR20B	2		C	
VCCIO	VCCIO2	-			VCCIO2	2			
J23	PR14A	2		T	PR20A	2		T	
-	-	-			GNDIO2	-			
-	-	-			-	-			
J26	NC	-			PR17B	2	RDQ15	C (LVDS)*	
H26	NC	-			PR17A	2	RDQ15	T (LVDS)*	
H27	NC	-			PR16B	2	RDQ15	C	
G26	NC	-			PR16A	2	RDQ15	T	

LFE2M50E/SE and LFE2M70E/SE Logic Signal Connections: 900 fpBGA

LFE2M50E/SE					LFE2M70E/SE			
Ball Number	Ball/Pad Function	Bank	Dual Function	Differential	Ball/Pad Function	Bank	Dual Function	Differential
-	-	-			VCCIO2	2		
H23	NC	-			PR15B	2	RDQ15	C (LVDS)*
H24	NC	-			PR15A	2	RDQS15	T (LVDS)*
D28	NC	-			PR14B	2	RDQ15	C
-	-	-			GNDIO2	-		
E28	NC	-			PR14A	2	RDQ15	T
G24	PR13B	2		C (LVDS)*	PR13B	2	RDQ15	C (LVDS)*
H25	PR13A	2		T (LVDS)*	PR13A	2	RDQ15	T (LVDS)*
D27	PR12B	2	RUM0_SPLL_C_FB_A	C	PR12B	2	RUM0_SPLL_C_FB_A/RDQ15	C
GNDIO	GNDIO2	-			VCCIO2	2		
E27	PR12A	2	RUM0_SPLL_T_FB_A	T	PR12A	2	RUM0_SPLL_T_FB_A/RDQ15	T
F26	PR11B	2	RUM0_SPLL_C_IN_A	C (LVDS)*	PR11B	2	RUM0_SPLL_C_IN_A/RDQ15	C (LVDS)*
G25	PR11A	2	RUM0_SPLL_T_IN_A	T (LVDS)*	PR11A	2	RUM0_SPLL_T_IN_A/RDQ15	T (LVDS)*
F24	PR9B	2	VREF2_2	C	PR9B	2	VREF2_2	C
VCCIO	VCCIO2	-			-	-		
GNDIO	GNDIO2	-			GNDIO2	-		
F25	PR9A	2	VREF1_2	T	PR9A	2	VREF1_2	T
VCCIO	VCCIO2	2			VCCIO2	2		
G23	XRES	-			XRES	1		
C30	URC_SQ_VCCR_X0	12			URC_SQ_VCCR_X0	12		
A29	URC_SQ_HDIN_P0	12		T	URC_SQ_HDIN_P0	12		T
B30	URC_SQ_VCCIB0	12			URC_SQ_VCCIB0	12		
B29	URC_SQ_HDIN_N0	12		C	URC_SQ_HDIN_N0	12		C
C27	URC_SQ_VCCT_X0	12			URC_SQ_VCCT_X0	12		
A26	URC_SQ_HDOUT_P0	12		T	URC_SQ_HDOUT_P0	12		T
A27	URC_SQ_VCCOB0	12			URC_SQ_VCCOB0	12		
B26	URC_SQ_HDOUT_N0	12		C	URC_SQ_HDOUT_N0	12		C
C26	URC_SQ_VCCT_X1	12			URC_SQ_VCCT_X1	12		
B25	URC_SQ_HDOUT_N1	12		C	URC_SQ_HDOUT_N1	12		C
C25	URC_SQ_VCCOB1	12			URC_SQ_VCCOB1	12		
A25	URC_SQ_HDOUT_P1	12		T	URC_SQ_HDOUT_P1	12		T
C29	URC_SQ_VCCR_X1	12			URC_SQ_VCCR_X1	12		
B28	URC_SQ_HDIN_N1	12		C	URC_SQ_HDIN_N1	12		C
C28	URC_SQ_VCCIB1	12			URC_SQ_VCCIB1	12		
A28	URC_SQ_HDIN_P1	12		T	URC_SQ_HDIN_P1	12		T
B24	URC_SQ_VCCAUX33	12			URC_SQ_VCCAUX33	12		
E24	URC_SQ_REFCLKN	12		C	URC_SQ_REFCLKN	12		C
D24	URC_SQ_REFCLKP	12		T	URC_SQ_REFCLKP	12		T
C24	URC_SQ_VCCP	12			URC_SQ_VCCP	12		
A20	URC_SQ_HDIN_P2	12		T	URC_SQ_HDIN_P2	12		T
C20	URC_SQ_VCCIB2	12			URC_SQ_VCCIB2	12		
B20	URC_SQ_HDIN_N2	12		C	URC_SQ_HDIN_N2	12		C
C19	URC_SQ_VCCR_X2	12			URC_SQ_VCCR_X2	12		
A23	URC_SQ_HDOUT_P2	12		T	URC_SQ_HDOUT_P2	12		T
C23	URC_SQ_VCCOB2	12			URC_SQ_VCCOB2	12		
B23	URC_SQ_HDOUT_N2	12		C	URC_SQ_HDOUT_N2	12		C
C22	URC_SQ_VCCT_X2	12			URC_SQ_VCCT_X2	12		
B22	URC_SQ_HDOUT_N3	12		C	URC_SQ_HDOUT_N3	12		C
A21	URC_SQ_VCCOB3	12			URC_SQ_VCCOB3	12		

LFE2M50E/SE and LFE2M70E/SE Logic Signal Connections: 900 fpBGA

LFE2M50E/SE					LFE2M70E/SE			
Ball Number	Ball/Pad Function	Bank	Dual Function	Differential	Ball/Pad Function	Bank	Dual Function	Differential
A22	URC_SQ_HDOU3P3	12		T	URC_SQ_HDOU3P3	12		T
C21	URC_SQ_VCCTX3	12			URC_SQ_VCCTX3	12		
B19	URC_SQ_HDINN3	12		C	URC_SQ_HDINN3	12		C
B18	URC_SQ_VCCIB3	12			URC_SQ_VCCIB3	12		
A19	URC_SQ_HDINP3	12		T	URC_SQ_HDINP3	12		T
C18	URC_SQ_VCCRX3	12			URC_SQ_VCCRX3	12		
D23	PT73B	1		C	PT82B	1		C
GNDIO	GNDIO1	-			GNDIO1	-		
E21	PT73A	1		T	PT82A	1		T
D26	PT72B	1		C	PT81B	1		C
E26	PT72A	1		T	PT81A	1		T
E23	PT71B	1		C	PT80B	1		C
-	-	-			VCCIO1	1		
G22	PT71A	1		T	PT80A	1		T
VCCIO	VCCIO1	1			-	-		
D22	PT70B	1		C	PT79B	1		C
F21	PT70A	1		T	PT79A	1		T
G18	PT69B	1		C	PT78B	1		C
H18	PT69A	1		T	PT78A	1		T
D20	PT68B	1		C	PT77B	1		C
GNDIO	GNDIO1	-			GNDIO1	-		
D21	PT68A	1		T	PT77A	1		T
E20	PT67B	1		C	PT76B	1		C
E19	PT67A	1		T	PT76A	1		T
D19	PT66B	1		C	PT75B	1		C
VCCIO	VCCIO1	1			VCCIO1	1		
E18	PT66A	1		T	PT75A	1		T
D18	PT65B	1		C	PT74B	1		C
C17	PT65A	1		T	PT74A	1		T
A17	PT64B	1		C	PT73B	1		C
B17	PT64A	1		T	PT73A	1		T
GNDIO	GNDIO1	-			GNDIO1	-		
VCCIO	VCCIO1	1			VCCIO1	1		
J18	NC	-			PT66B	1		C
J19	NC	-			PT66A	1		T
H17	NC	-			PT65B	1		C
J17	NC	-			PT65A	1		T
F18	NC	-			PT64B	1		C
F17	NC	-			PT64A	1		T
-	-	-			GNDIO1	-		
A16	PT54B	1		C	PT63B	1		C
B16	PT54A	1		T	PT63A	1		T
G17	PT53B	1		C	PT62B	1		C
G16	PT53A	1		T	PT62A	1		T
VCCIO	VCCIO1	1			VCCIO1	1		
H16	PT52B	1		C	PT61B	1		C
F16	PT52A	1		T	PT61A	1		T
J16	PT51B	1		C	PT60B	1		C
G15	PT51A	1		T	PT60A	1		T

LFE2M50E/SE and LFE2M70E/SE Logic Signal Connections: 900 fpBGA

LFE2M50E/SE					LFE2M70E/SE			
Ball Number	Ball/Pad Function	Bank	Dual Function	Differential	Ball/Pad Function	Bank	Dual Function	Differential
GNDIO	GNDIO1	-			GNDIO1	-		
C16	PT50B	1		C	PT59B	1		C
D16	PT50A	1		T	PT59A	1		T
J15	PT49B	1		C	PT58B	1		C
H15	PT49A	1		T	PT58A	1		T
VCCIO	VCCIO1	1			VCCIO1	1		
A15	PT48B	1	VREF2_1	C	PT57B	1	VREF2_1	C
B15	PT48A	1	VREF1_1	T	PT57A	1	VREF1_1	T
F15	PT47B	1	PCLKC1_0	C	PT56B	1	PCLKC1_0	C
E16	PT47A	1	PCLKT1_0	T	PT56A	1	PCLKT1_0	T
C15	PT46B	0	PCLKC0_0	C	PT55B	0	PCLKC0_0	C
GNDIO	GNDIO0	-			GNDIO0	-		
D15	PT46A	0	PCLKT0_0	T	PT55A	0	PCLKT0_0	T
C14	PT45B	0	VREF2_0	C	PT54B	0	VREF2_0	C
E15	PT45A	0	VREF1_0	T	PT54A	0	VREF1_0	T
G14	PT44B	0		C	PT53B	0		C
VCCIO	VCCIO0	0			VCCIO0	0		
J14	PT44A	0		T	PT53A	0		T
F14	PT43B	0		C	PT52B	0		C
H14	PT43A	0		T	PT52A	0		T
A14	PT42B	0		C	PT51B	0		C
B14	PT42A	0		T	PT51A	0		T
D13	PT41B	0		C	PT50B	0		C
GNDIO	GNDIO0	-			GNDIO0	-		
F13	PT41A	0		T	PT50A	0		T
G13	PT40B	0		C	PT49B	0		C
VCCIO	VCCIO0	0			VCCIO0	0		
J11	PT40A	0		T	PT49A	0		T
D4	PT38B	0		C	PT47B	0		C
D5	PT38A	0		T	PT47A	0		T
E5	PT37B	0		C	PT46B	0		C
F6	PT37A	0		T	PT46A	0		T
GNDIO	GNDIO0	-			GNDIO0	-		
VCCIO	VCCIO0	0			VCCIO0	0		
F7	PT34B	0		C	PT43B	0		C
D8	PT34A	0		T	PT43A	0		T
GNDIO	GNDIO0	-			GNDIO0	-		
J13	PT32B	0		C	PT41B	0		C
G11	PT32A	0		T	PT41A	0		T
H13	PT31B	0		C	PT40B	0		C
H12	PT31A	0		T	PT40A	0		T
VCCIO	VCCIO0	0			VCCIO0	0		
E8	PT30B	0		C	PT39B	0		C
D9	PT30A	0		T	PT39A	0		T
D12	PT28B	0		C	PT37B	0		C
GNDIO	GNDIO0	-			GNDIO0	-		
E13	PT28A	0		T	PT37A	0		T
VCCIO	VCCIO0	0			VCCIO0	0		
GNDIO	GNDIO0	-			GNDIO0	-		

LFE2M50E/SE and LFE2M70E/SE Logic Signal Connections: 900 fpBGA

LFE2M50E/SE					LFE2M70E/SE			
Ball Number	Ball/Pad Function	Bank	Dual Function	Differential	Ball/Pad Function	Bank	Dual Function	Differential
J12	PT5B	0		C	PT31B	0		C
GNDIO	GNDIO0	-			-	-		
VCCIO	VCCIO0	0			VCCIO0	0		
H10	PT5A	0		T	PT31A	0		T
E12	PT4B	0		C	PT30B	0		C
D11	PT4A	0		T	PT30A	0		T
H11	PT3B	0		C	PT29B	0		C
F11	PT3A	0		T	PT29A	0		T
C13	VCC	-			ULC_SQ_VCCRX0	11		
A12	PT19A	0		T	ULC_SQ_HDINP0	11		T
B13	NC	-			ULC_SQ_VCCIB0	11		
B12	PT19B	0		C	ULC_SQ_HDINN0	11		C
C10	VCC	-			ULC_SQ_VCCTX0	11		
A9	PT17A	0		T	ULC_SQ_HDOUTP0	11		T
A10	NC	-			ULC_SQ_VCCOB0	11		
B9	PT17B	0		C	ULC_SQ_HDOUTN0	11		C
C9	VCC	-			ULC_SQ_VCCTX1	11		
B8	PT18B	0		C	ULC_SQ_HDOUTN1	11		C
C8	NC	-			ULC_SQ_VCCOB1	11		
A8	PT18A	0		T	ULC_SQ_HDOUTP1	11		T
C12	VCC	-			ULC_SQ_VCCRX1	11		
B11	PT16B	0		C	ULC_SQ_HDINN1	11		C
C11	NC	-			ULC_SQ_VCCIB1	11		
A11	PT16A	0		T	ULC_SQ_HDINP1	11		T
B7	VCCAUX	-			ULC_SQ_VCCAUX33	11		
E7	PT15B	0		C	ULC_SQ_REFCLKN	11		C
D7	PT15A	0		T	ULC_SQ_REFCLKP	11		T
C7	VCC	-			ULC_SQ_VCCP	11		
A3	PT12A	0		T	ULC_SQ_HDINP2	11		T
C3	NC	-			ULC_SQ_VCCIB2	11		
B3	PT12B	0		C	ULC_SQ_HDINN2	11		C
C2	VCC	-			ULC_SQ_VCCRX2	11		
A6	PT14A	0		T	ULC_SQ_HDOUTP2	11		T
C6	NC	-			ULC_SQ_VCCOB2	11		
B6	PT14B	0		C	ULC_SQ_HDOUTN2	11		C
C5	VCC	-			ULC_SQ_VCCTX2	11		
B5	PT13B	0		C	ULC_SQ_HDOUTN3	11		C
A4	NC	-			ULC_SQ_VCCOB3	11		
A5	PT13A	0		T	ULC_SQ_HDOUTP3	11		T
C4	VCC	-			ULC_SQ_VCCTX3	11		
B2	PT11B	0		C	ULC_SQ_HDINN3	11		C
B1	NC	-			ULC_SQ_VCCIB3	11		
A2	PT11A	0		T	ULC_SQ_HDINP3	11		T
C1	VCC	-			ULC_SQ_VCCRX3	11		
L12	VCC	-			VCC	-		
L13	VCC	-			VCC	-		
L18	VCC	-			VCC	-		
L19	VCC	-			VCC	-		
M11	VCC	-			VCC	-		

LFE2M50E/SE and LFE2M70E/SE Logic Signal Connections: 900 fpBGA

LFE2M50E/SE					LFE2M70E/SE			
Ball Number	Ball/Pad Function	Bank	Dual Function	Differential	Ball/Pad Function	Bank	Dual Function	Differential
M12	VCC	-			VCC	-		
M13	VCC	-			VCC	-		
M14	VCC	-			VCC	-		
M15	VCC	-			VCC	-		
M16	VCC	-			VCC	-		
M17	VCC	-			VCC	-		
M18	VCC	-			VCC	-		
M19	VCC	-			VCC	-		
M20	VCC	-			VCC	-		
N11	VCC	-			VCC	-		
N12	VCC	-			VCC	-		
N19	VCC	-			VCC	-		
N20	VCC	-			VCC	-		
P12	VCC	-			VCC	-		
P19	VCC	-			VCC	-		
R12	VCC	-			VCC	-		
R19	VCC	-			VCC	-		
T12	VCC	-			VCC	-		
T19	VCC	-			VCC	-		
U12	VCC	-			VCC	-		
U19	VCC	-			VCC	-		
V11	VCC	-			VCC	-		
V12	VCC	-			VCC	-		
V19	VCC	-			VCC	-		
V20	VCC	-			VCC	-		
W11	VCC	-			VCC	-		
W12	VCC	-			VCC	-		
W13	VCC	-			VCC	-		
W14	VCC	-			VCC	-		
W15	VCC	-			VCC	-		
W16	VCC	-			VCC	-		
W17	VCC	-			VCC	-		
W18	VCC	-			VCC	-		
W19	VCC	-			VCC	-		
W20	VCC	-			VCC	-		
Y12	VCC	-			VCC	-		
Y13	VCC	-			VCC	-		
Y18	VCC	-			VCC	-		
Y19	VCC	-			VCC	-		
D14	VCCIO0	0			VCCIO0	0		
E6	VCCIO0	0			VCCIO0	0		
E9	VCCIO0	0			VCCIO0	0		
F12	VCCIO0	0			VCCIO0	0		
K12	VCCIO0	0			VCCIO0	0		
K13	VCCIO0	0			VCCIO0	0		
D17	VCCIO1	1			VCCIO1	1		
E22	VCCIO1	1			VCCIO1	1		
E25	VCCIO1	1			VCCIO1	1		
F19	VCCIO1	1			VCCIO1	1		

LFE2M50E/SE and LFE2M70E/SE Logic Signal Connections: 900 fpBGA

LFE2M50E/SE					LFE2M70E/SE			
Ball Number	Ball/Pad Function	Bank	Dual Function	Differential	Ball/Pad Function	Bank	Dual Function	Differential
K18	VCCIO1	1			VCCIO1	1		
K19	VCCIO1	1			VCCIO1	1		
F28	VCCIO2	2			VCCIO2	2		
J25	VCCIO2	2			VCCIO2	2		
K28	VCCIO2	2			VCCIO2	2		
M21	VCCIO2	2			VCCIO2	2		
M24	VCCIO2	2			VCCIO2	2		
N21	VCCIO2	2			VCCIO2	2		
N28	VCCIO2	2			VCCIO2	2		
P21	VCCIO2	2			VCCIO2	2		
R25	VCCIO2	2			VCCIO2	2		
AA28	VCCIO3	3			VCCIO3	3		
AB25	VCCIO3	3			VCCIO3	3		
AE28	VCCIO3	3			VCCIO3	3		
T25	VCCIO3	3			VCCIO3	3		
U21	VCCIO3	3			VCCIO3	3		
V21	VCCIO3	3			VCCIO3	3		
V28	VCCIO3	3			VCCIO3	3		
W21	VCCIO3	3			VCCIO3	3		
W24	VCCIO3	3			VCCIO3	3		
AA18	VCCIO4	4			VCCIO4	4		
AA19	VCCIO4	4			VCCIO4	4		
AE19	VCCIO4	4			VCCIO4	4		
AF22	VCCIO4	4			VCCIO4	4		
AG17	VCCIO4	4			VCCIO4	4		
AG25	VCCIO4	4			VCCIO4	4		
AA12	VCCIO5	5			VCCIO5	5		
AA13	VCCIO5	5			VCCIO5	5		
AE12	VCCIO5	5			VCCIO5	5		
AF9	VCCIO5	5			VCCIO5	5		
AG14	VCCIO5	5			VCCIO5	5		
AG6	VCCIO5	5			VCCIO5	5		
AA3	VCCIO6	6			VCCIO6	6		
AB6	VCCIO6	6			VCCIO6	6		
AE3	VCCIO6	6			VCCIO6	6		
T6	VCCIO6	6			VCCIO6	6		
U10	VCCIO6	6			VCCIO6	6		
V10	VCCIO6	6			VCCIO6	6		
V3	VCCIO6	6			VCCIO6	6		
W10	VCCIO6	6			VCCIO6	6		
W7	VCCIO6	6			VCCIO6	6		
F3	VCCIO7	7			VCCIO7	7		
J6	VCCIO7	7			VCCIO7	7		
K3	VCCIO7	7			VCCIO7	7		
M10	VCCIO7	7			VCCIO7	7		
M7	VCCIO7	7			VCCIO7	7		
N10	VCCIO7	7			VCCIO7	7		
N3	VCCIO7	7			VCCIO7	7		
P10	VCCIO7	7			VCCIO7	7		

LFE2M50E/SE and LFE2M70E/SE Logic Signal Connections: 900 fpBGA

LFE2M50E/SE					LFE2M70E/SE			
Ball Number	Ball/Pad Function	Bank	Dual Function	Differential	Ball/Pad Function	Bank	Dual Function	Differential
R6	VCCIO7	7			VCCIO7	7		
AA25	VCCIO8	8			VCCIO8	8		
AD28	VCCIO8	8			VCCIO8	8		
AA10	VCCAUX	-			VCCAUX	-		
AA11	VCCAUX	-			VCCAUX	-		
AA20	VCCAUX	-			VCCAUX	-		
AA21	VCCAUX	-			VCCAUX	-		
K10	VCCAUX	-			VCCAUX	-		
K11	VCCAUX	-			VCCAUX	-		
K20	VCCAUX	-			VCCAUX	-		
K21	VCCAUX	-			VCCAUX	-		
L10	VCCAUX	-			VCCAUX	-		
L11	VCCAUX	-			VCCAUX	-		
L20	VCCAUX	-			VCCAUX	-		
L21	VCCAUX	-			VCCAUX	-		
Y10	VCCAUX	-			VCCAUX	-		
Y11	VCCAUX	-			VCCAUX	-		
Y20	VCCAUX	-			VCCAUX	-		
Y21	VCCAUX	-			VCCAUX	-		
A1	GND	-			GND	-		
A13	GND	-			GND	-		
A18	GND	-			GND	-		
A24	GND	-			GND	-		
A30	GND	-			GND	-		
A7	GND	-			GND	-		
AA14	GND	-			GND	-		
AA15	GND	-			GND	-		
AA16	GND	-			GND	-		
AA17	GND	-			GND	-		
AA24	GND	-			GND	-		
AA27	GND	-			GND	-		
AA4	GND	-			GND	-		
AB24	GND	-			GND	-		
AB7	GND	-			GND	-		
AD12	GND	-			GND	-		
AD19	GND	-			GND	-		
AD27	GND	-			GND	-		
AE22	GND	-			GND	-		
AE27	GND	-			GND	-		
AE4	GND	-			GND	-		
AE9	GND	-			GND	-		
AF14	GND	-			GND	-		
AF17	GND	-			GND	-		
AF25	GND	-			GND	-		
AF6	GND	-			GND	-		
AJ10	GND	-			GND	-		
AJ21	GND	-			GND	-		
AJ27	GND	-			GND	-		
AJ4	GND	-			GND	-		

LFE2M50E/SE and LFE2M70E/SE Logic Signal Connections: 900 fpBGA

LFE2M50E/SE					LFE2M70E/SE			
Ball Number	Ball/Pad Function	Bank	Dual Function	Differential	Ball/Pad Function	Bank	Dual Function	Differential
AK1	GND	-			GND	-		
AK13	GND	-			GND	-		
AK18	GND	-			GND	-		
AK24	GND	-			GND	-		
AK30	GND	-			GND	-		
AK7	GND	-			GND	-		
B10	GND	-			GND	-		
B21	GND	-			GND	-		
B27	GND	-			GND	-		
B4	GND	-			GND	-		
D25	GND	-			GND	-		
D6	GND	-			GND	-		
E14	GND	-			GND	-		
E17	GND	-			GND	-		
F22	GND	-			GND	-		
F27	GND	-			GND	-		
F4	GND	-			GND	-		
F9	GND	-			GND	-		
G12	GND	-			GND	-		
G19	GND	-			GND	-		
J24	GND	-			GND	-		
J7	GND	-			GND	-		
K14	GND	-			GND	-		
K15	GND	-			GND	-		
K16	GND	-			GND	-		
K17	GND	-			GND	-		
K27	GND	-			GND	-		
K4	GND	-			GND	-		
L14	GND	-			GND	-		
L15	GND	-			GND	-		
L16	GND	-			GND	-		
L17	GND	-			GND	-		
M23	GND	-			GND	-		
M8	GND	-			GND	-		
N14	GND	-			GND	-		
N15	GND	-			GND	-		
N16	GND	-			GND	-		
N17	GND	-			GND	-		
N27	GND	-			GND	-		
N4	GND	-			GND	-		
P11	GND	-			GND	-		
P13	GND	-			GND	-		
P14	GND	-			GND	-		
P15	GND	-			GND	-		
P16	GND	-			GND	-		
P17	GND	-			GND	-		
P18	GND	-			GND	-		
P20	GND	-			GND	-		
R10	GND	-			GND	-		

LFE2M50E/SE and LFE2M70E/SE Logic Signal Connections: 900 fpBGA

LFE2M50E/SE					LFE2M70E/SE			
Ball Number	Ball/Pad Function	Bank	Dual Function	Differential	Ball/Pad Function	Bank	Dual Function	Differential
R11	GND	-			GND	-		
R13	GND	-			GND	-		
R14	GND	-			GND	-		
R15	GND	-			GND	-		
R16	GND	-			GND	-		
R17	GND	-			GND	-		
R18	GND	-			GND	-		
R20	GND	-			GND	-		
R21	GND	-			GND	-		
R24	GND	-			GND	-		
R7	GND	-			GND	-		
T10	GND	-			GND	-		
T11	GND	-			GND	-		
T13	GND	-			GND	-		
T14	GND	-			GND	-		
T15	GND	-			GND	-		
T16	GND	-			GND	-		
T17	GND	-			GND	-		
T18	GND	-			GND	-		
T20	GND	-			GND	-		
T21	GND	-			GND	-		
T24	GND	-			GND	-		
T7	GND	-			GND	-		
U11	GND	-			GND	-		
U13	GND	-			GND	-		
U14	GND	-			GND	-		
U15	GND	-			GND	-		
U16	GND	-			GND	-		
U17	GND	-			GND	-		
U18	GND	-			GND	-		
U20	GND	-			GND	-		
V14	GND	-			GND	-		
V15	GND	-			GND	-		
V16	GND	-			GND	-		
V17	GND	-			GND	-		
V27	GND	-			GND	-		
V4	GND	-			GND	-		
W23	GND	-			GND	-		
W8	GND	-			GND	-		
Y14	GND	-			GND	-		
Y15	GND	-			GND	-		
Y16	GND	-			GND	-		
Y17	GND	-			GND	-		
AA26	NC	-			NC	-		
AB10	PL73B	6	LDQ71	C (LVDS)*	NC	-		
AB11	NC	-			NC	-		
AB12	NC	-			NC	-		
AB13	NC	-			NC	-		
AB14	NC	-			NC	-		

LFE2M50E/SE and LFE2M70E/SE Logic Signal Connections: 900 fpBGA

LFE2M50E/SE					LFE2M70E/SE			
Ball Number	Ball/Pad Function	Bank	Dual Function	Differential	Ball/Pad Function	Bank	Dual Function	Differential
AB15	NC	-			NC	-		
AB16	NC	-			NC	-		
AB17	NC	-			NC	-		
AB19	NC	-			NC	-		
AB20	NC	-			NC	-		
AB21	NC	-			NC	-		
AB9	PL73A	6	LDQ71	T (LVDS)*	NC	-		
AC10	PL74B	6	LDQ71	C	NC	-		
AC11	NC	-			NC	-		
AC21	NC	-			NC	-		
AC22	NC	-			NC	-		
AC8	PL70B	6	LDQ71	C	NC	-		
AC9	PL74A	6	LDQ71	T	NC	-		
AD21	NC	-			NC	-		
AD22	NC	-			NC	-		
AD4	PL68A	6	LDQ71	T	NC	-		
AD5	PL68B	6	LDQ71	C	NC	-		
AD6	PL71A	6	LDQS71	T (LVDS)*	NC	-		
AD7	PL72A	6	LDQ71	T	NC	-		
AD8	PL72B	6	LDQ71	C	NC	-		
AE23	NC	-			NC	-		
AE5	PL69A	6	LDQ71	T (LVDS)*	NC	-		
AE6	PL70A	6	LDQ71	T	NC	-		
AE7	PL71B	6	LDQ71	C (LVDS)*	NC	-		
AF20	NC	-			NC	-		
AF23	NC	-			NC	-		
AF5	PL69B	6	LDQ71	C (LVDS)*	NC	-		
AG23	NC	-			NC	-		
AG26	NC	-			NC	-		
D10	PT10A	0		T	NC	-		
E10	PT9B	0		C	NC	-		
E11	PT10B	0		C	NC	-		
F10	PT9A	0		T	NC	-		
F20	NC	-			NC	-		
F23	NC	-			NC	-		
F8	PL6B	7	LDQ6	C (LVDS)*	NC	-		
G10	NC	-			NC	-		
G20	NC	-			NC	-		
G21	NC	-			NC	-		
G7	PL8A	7	LDQ6	T (LVDS)*	NC	-		
G8	PL6A	7	LDQS6****	T (LVDS)*	NC	-		
G9	PL5A	7	LDQ6	T	NC	-		
H19	NC	-			NC	-		
H20	NC	-			NC	-		
H21	NC	-			NC	-		
H22	NC	-			NC	-		
H6	PL8B	7	LDQ6	C (LVDS)*	NC	-		
H8	PL5B	7	LDQ6	C	NC	-		
H9	PL2A	7	LDQ6	T (LVDS)*	NC	-		

LFE2M50E/SE and LFE2M70E/SE Logic Signal Connections: 900 fpBGA

LFE2M50E/SE					LFE2M70E/SE			
Ball Number	Ball/Pad Function	Bank	Dual Function	Differential	Ball/Pad Function	Bank	Dual Function	Differential
J10	PL2B	7	LDQ6	C (LVDS)*	NC	-		
J20	NC	-			NC	-		
J21	NC	-			NC	-		
J9	PL4A	7	LDQ6	T (LVDS)*	NC	-		
K9	PL4B	7	LDQ6	C (LVDS)*	NC	-		
R9	NC	-			NC	-		
U22	NC	-			NC	-		
W9	NC	-			NC	-		
N13	VCCPLL	-			VCCPLL	-		
N18	VCCPLL	-			VCCPLL	-		
V13	VCCPLL	-			VCCPLL	-		
V18	VCCPLL	-			VCCPLL	-		

* Supports true LVDS. Other differential signals must be emulated with external resistors.

** These dedicated input pins can be used for GPLLs or GDLLs within the respective quadrant.

*** These sysCONFIG pins are dedicated I/O pins for configuration. The outputs are actively driven during normal device operation.

****Due to packaging bond out option, this DQS does not have all the necessary DQ pins bonded out for a full 8-bit data width.

Note: VCCIO and GND pads are used to determine the average DC current drawn by I/Os between GND/VCCIO connections, or between the last GND/VCCIO in an I/O bank and the end of an I/O bank. The substrate pads listed in the Pin Table do not necessarily have a one to one connection with a package ball or pin.

LFE2M100E/SE Logic Signal Connections: 900 fpBGA

LFE2M100E/SE				
Ball Number	Ball/Pad Function	Bank	Dual Function	Differential
VCCIO	VCCIO7	7		
D2	PL9A	7	VREF2_7	T
D3	PL9B	7	VREF1_7	C
GNDIO	GNDIO7	-		
J8	PL11A	7	LUM0_SPLLT_IN_A/LDQ15	T (LVDS)*
H7	PL11B	7	LUM0_SPLLC_IN_A/LDQ15	C (LVDS)*
E3	PL12A	7	LUM0_SPLLT_FB_A/LDQ15	T
E4	PL12B	7	LUM0_SPLLC_FB_A/LDQ15	C
-	-	-		
VCCIO	VCCIO7	7		
G6	PL13A	7	LDQ15	T (LVDS)*
F5	PL13B	7	LDQ15	C (LVDS)*
E2	PL14A	7	LDQ15	T
D1	PL14B	7	LDQ15	C
GNDIO	GNDIO7	-		
G5	PL15A	7	LDQS15	T (LVDS)*
G4	PL15B	7	LDQ15	C (LVDS)*
K7	PL16A	7	LDQ15	T
VCCIO	VCCIO7	7		
K8	PL16B	7	LDQ15	C
E1	PL17A	7	LDQ15	T (LVDS)*
F2	PL17B	7	LDQ15	C (LVDS)*
F1	PL18A	7	LDQ15	T
GNDIO	GNDIO7	-		
G3	PL18B	7	LDQ15	C
GNDIO	GNDIO7	-		
VCCIO	VCCIO7	7		
H5	PL25A	7	LDQ23	T (LVDS)*
H4	PL25B	7	LDQ23	C (LVDS)*
J5	PL26A	7	LDQ23	T
J4	PL26B	7	LDQ23	C
GNDIO	GNDIO7	-		
G2	PL28A	7	LDQ32	T (LVDS)*
G1	PL28B	7	LDQ32	C (LVDS)*
L9	PL29A	7	LDQ32	T
L7	PL29B	7	LDQ32	C
VCCIO	VCCIO7	7		
K6	PL30A	7	LDQ32	T (LVDS)*
K5	PL30B	7	LDQ32	C (LVDS)*
L8	PL31A	7	LDQ32	T
L6	PL31B	7	LDQ32	C
GNDIO	GNDIO7	-		

LFE2M100E/SE Logic Signal Connections: 900 fpBGA (Cont.)

LFE2M100E/SE				
Ball Number	Ball/Pad Function	Bank	Dual Function	Differential
H3	PL32A	7	LDQS32	T (LVDS)*
H2	PL32B	7	LDQ32	C (LVDS)*
N8	PL33A	7	LDQ32	T
VCCIO	VCCIO7	7		
M9	PL33B	7	LDQ32	C
J3	PL34A	7	LDQ32	T (LVDS)*
-	-	-		
J2	PL34B	7	LDQ32	C (LVDS)*
H1	PL35A	7	LDQ32	T
GNDIO	GNDIO7	-		
J1	PL35B	7	LDQ32	C
VCCIO	VCCIO7	7		
GNDIO	GNDIO7	-		
L5	PL41A	7	LDQ45	T (LVDS)*
L4	PL41B	7	LDQ45	C (LVDS)*
N9	PL42A	7	LDQ45	T
N7	PL42B	7	LDQ45	C
VCCIO	VCCIO7	7		
K2	PL43A	7	LDQ45	T (LVDS)*
K1	PL43B	7	LDQ45	C (LVDS)*
P9	PL44A	7	LDQ45	T
P7	PL44B	7	LDQ45	C
GNDIO	GNDIO7	-		
M6	PL45A	7	LDQS45	T (LVDS)*
M5	PL45B	7	LDQ45	C (LVDS)*
N5	PL46A	7	LDQ45	T
VCCIO	VCCIO7	7		
N6	PL46B	7	LDQ45	C
M4	PL47A	7	LDQ45	T (LVDS)*
M3	PL47B	7	LDQ45	C (LVDS)*
P6	PL48A	7	LDQ45	T
GNDIO	GNDIO7	-		
P8	PL48B	7	LDQ45	C
L3	PL50A	7	LUM3_SPLLT_IN_A/LDQ54	T (LVDS)*
L2	PL50B	7	LUM3_SPLLC_IN_A/LDQ54	C (LVDS)*
P5	PL51A	7	LUM3_SPLLT_FB_A/LDQ54	T
P4	PL51B	7	LUM3_SPLLC_FB_A/LDQ54	C
VCCIO	VCCIO7	7		
L1	PL52A	7	LDQ54	T (LVDS)*
M2	PL52B	7	LDQ54	C (LVDS)*
R5	PL53A	7	LDQ54	T
R4	PL53B	7	LDQ54	C
GNDIO	GNDIO7	-		

LFE2M100E/SE Logic Signal Connections: 900 fpBGA (Cont.)

LFE2M100E/SE				
Ball Number	Ball/Pad Function	Bank	Dual Function	Differential
M1	PL54A	7	LDQS54	T (LVDS)*
N2	PL54B	7	LDQ54	C (LVDS)*
R8	PL55A	7	LDQ54	T
VCCIO	VCCIO7	7		
T9	PL55B	7	LDQ54	C
P3	PL56A	7	LDQ54	T (LVDS)*
P2	PL56B	7	LDQ54	C (LVDS)*
N1	PL57A	7	PCLKT7_0/LDQ54	T
GNDIO	GNDIO7	-		
P1	PL57B	7	PCLKC7_0/LDQ54	C
T5	PL59A	6	PCLKT6_0/LDQ63	T (LVDS)*
T4	PL59B	6	PCLKC6_0/LDQ63	C (LVDS)*
U7	PL60A	6	VREF2_6/LDQ63	T
T8	PL60B	6	VREF1_6/LDQ63	C
R3	PL61A	6	LDQ63	T (LVDS)*
VCCIO	VCCIO6	6		
R2	PL61B	6	LDQ63	C (LVDS)*
R1	PL62A	6	LDQ63	T
T1	PL62B	6	LDQ63	C
GNDIO	GNDIO6	-		
VCCIO	VCCIO6	6		
T3	PL65A	6	LLM4_SPLLT_IN_A/LDQ63	T (LVDS)*
T2	PL65B	6	LLM4_SPLLC_IN_A/LDQ63	C (LVDS)*
U9	PL66A	6	LLM4_SPLLT_FB_A/LDQ63	T
U8	PL66B	6	LLM4_SPLLC_FB_A/LDQ63	C
GNDIO	GNDIO6	-		
U5	PL68A	6	LDQ72	T (LVDS)*
U4	PL68B	6	LDQ72	C (LVDS)*
V9	PL69A	6	LDQ72	T
V7	PL69B	6	LDQ72	C
VCCIO	VCCIO6	6		
U3	PL70A	6	LDQ72	T (LVDS)*
U2	PL70B	6	LDQ72	C (LVDS)*
V8	PL71A	6	LDQ72	T
U6	PL71B	6	LDQ72	C
GNDIO	GNDIO6	-		
U1	PL72A	6	LDQS72	T (LVDS)*
V2	PL72B	6	LDQ72	C (LVDS)*
V5	PL73A	6	LDQ72	T
VCCIO	VCCIO6	6		
V6	PL73B	6	LDQ72	C
V1	PL74A	6	LDQ72	T (LVDS)*
W1	PL74B	6	LDQ72	C (LVDS)*

LFE2M100E/SE Logic Signal Connections: 900 fpBGA (Cont.)

LFE2M100E/SE				
Ball Number	Ball/Pad Function	Bank	Dual Function	Differential
W5	PL75A	6	LDQ72	T
GNDIO	GNDIO6	-		
W6	PL75B	6	LDQ72	C
W3	PL77A	6	LDQ81	T (LVDS)*
W4	PL77B	6	LDQ81	C (LVDS)*
W2	PL78A	6	LDQ81	T
Y4	PL78B	6	LDQ81	C
Y1	PL79A	6	LDQ81	T (LVDS)*
VCCIO	VCCIO6	6		
Y2	PL79B	6	LDQ81	C (LVDS)*
Y5	PL80A	6	LDQ81	T
Y6	PL80B	6	LDQ81	C
AA1	PL81A	6	LDQS81	T (LVDS)*
GNDIO	GNDIO6	-		
AA2	PL81B	6	LDQ81	C (LVDS)*
Y3	PL82A	6	LDQ81	T
AB1	PL82B	6	LDQ81	C
VCCIO	VCCIO6	6		
Y9	PL83A	6	LDQ81	T (LVDS)*
Y8	PL83B	6	LDQ81	C (LVDS)*
Y7	PL84A	6	LDQ81	T
AA7	PL84B	6	LDQ81	C
GNDIO	GNDIO6	-		
VCCIO	VCCIO6	6		
AB2	PL95A	6	LDQ99	T (LVDS)*
AB3	PL95B	6	LDQ99	C (LVDS)*
AA5	PL96A	6	LDQ99	T
AA6	PL96B	6	LDQ99	C
AB4	PL97A	6	LDQ99	T (LVDS)*
VCCIO	VCCIO6	6		
AB5	PL97B	6	LDQ99	C (LVDS)*
AA8	PL98A	6	LDQ99	T
AA9	PL98B	6	LDQ99	C
AC1	PL99A	6	LLM0_GPLLT_IN_A**/LDQS99	T (LVDS)*
GNDIO	GNDIO6	-		
AC2	PL99B	6	LLM0_GPLLC_IN_A**/LDQ99	C (LVDS)*
AC4	PL100A	6	LLM0_GPLLT_FB_A/LDQ99	T
AC3	PL100B	6	LLM0_GPLLC_FB_A/LDQ99	C
VCCIO	VCCIO6	6		
AC7	PL101A	6	LLM0_GDLLT_IN_A**/LDQ99	T (LVDS)*
AC6	PL101B	6	LLM0_GDLLC_IN_A**/LDQ99	C (LVDS)*
AC5	PL102A	6	LLM0_GDLLT_FB_A/LDQ99	T
AD3	PL102B	6	LLM0_GDLLC_FB_A/LDQ99	C

LFE2M100E/SE Logic Signal Connections: 900 fpBGA (Cont.)

LFE2M100E/SE				
Ball Number	Ball/Pad Function	Bank	Dual Function	Differential
GNDIO	GNDIO6	-		
AB8	LLM0_PLLCAP	6		
AD2	PL104A	6		T
AD1	PL104B	6		C
AE2	TCK	-		
AE1	TDI	-		
AF2	TMS	-		
AF1	TDO	-		
AG1	VCCJ	-		
AH1	LLC_SQ_VCCR3	14		
AK2	LLC_SQ_HDINP3	14		T
AJ1	LLC_SQ_VCCIB3	14		
AJ2	LLC_SQ_HDINN3	14		C
AH4	LLC_SQ_VCCTX3	14		
AK5	LLC_SQ_HDOUTP3	14		T
AK4	LLC_SQ_VCCOB3	14		
AJ5	LLC_SQ_HDOUTN3	14		C
AH5	LLC_SQ_VCCTX2	14		
AJ6	LLC_SQ_HDOUTN2	14		C
AH6	LLC_SQ_VCCOB2	14		
AK6	LLC_SQ_HDOUTP2	14		T
AH2	LLC_SQ_VCCR2	14		
AJ3	LLC_SQ_HDINN2	14		C
AH3	LLC_SQ_VCCIB2	14		
AK3	LLC_SQ_HDINP2	14		T
AH7	LLC_SQ_VCCP	14		
AG7	LLC_SQ_REFCLKP	14		T
AF7	LLC_SQ_REFCLKN	14		C
AJ7	LLC_SQ_VCCAUX33	14		
AK11	LLC_SQ_HDINP1	14		T
AH11	LLC_SQ_VCCIB1	14		
AJ11	LLC_SQ_HDINN1	14		C
AH12	LLC_SQ_VCCR1	14		
AK8	LLC_SQ_HDOUTP1	14		T
AH8	LLC_SQ_VCCOB1	14		
AJ8	LLC_SQ_HDOUTN1	14		C
AH9	LLC_SQ_VCCTX1	14		
AJ9	LLC_SQ_HDOUTN0	14		C
AK10	LLC_SQ_VCCOB0	14		
AK9	LLC_SQ_HDOUTP0	14		T
AH10	LLC_SQ_VCCTX0	14		
AJ12	LLC_SQ_HDINN0	14		C
AJ13	LLC_SQ_VCCIB0	14		

LFE2M100E/SE Logic Signal Connections: 900 fpBGA (Cont.)

LFE2M100E/SE				
Ball Number	Ball/Pad Function	Bank	Dual Function	Differential
AK12	LLC_SQ_HDINP0	14		T
AH13	LLC_SQ_VCCR0	14		
AF10	PB30A	5	BDQ33	T
AE8	PB30B	5	BDQ33	C
AE11	PB31A	5	BDQ33	T
VCCIO	VCCIO5	5		
AD9	PB31B	5	BDQ33	C
AE10	PB32A	5	BDQ33	T
AD10	PB32B	5	BDQ33	C
AE13	PB33A	5	BDQS33	T
GNDIO	GNDIO5	-		
AC12	PB33B	5	BDQ33	C
AG2	PB34A	5	BDQ33	T
AG3	PB34B	5	BDQ33	C
AD13	PB35A	5	BDQ33	T
VCCIO	VCCIO5	5		
AC13	PB35B	5	BDQ33	C
AE14	PB36A	5	BDQ33	T
AC14	PB36B	5	BDQ33	C
AF3	PB37A	5	BDQ33	T
GNDIO	GNDIO5	-		
AF4	PB37B	5	BDQ33	C
-	-	-		
AG4	PB38A	5	BDQ42	T
AG5	PB38B	5	BDQ42	C
GNDIO	GNDIO5	-		
-	-	-		
AD11	PB48A	5	BDQ51	T
AF13	PB48B	5	BDQ51	C
AF12	PB49A	5	BDQ51	T
VCCIO	VCCIO5	5		
AD14	PB49B	5	BDQ51	C
AG8	PB50A	5	BDQ51	T
AF8	PB50B	5	BDQ51	C
AE15	PB51A	5	BDQS51****	T
GNDIO	GNDIO5	-		
-	-	-		
AC15	PB51B	5	BDQ51	C
VCCIO	VCCIO5	5		
GNDIO	GNDIO5	-		
AD15	PB56A	5	BDQ60	T
AF15	PB56B	5	BDQ60	C
AG10	PB57A	5	BDQ60	T

LFE2M100E/SE Logic Signal Connections: 900 fpBGA (Cont.)

LFE2M100E/SE				
Ball Number	Ball/Pad Function	Bank	Dual Function	Differential
AG9	PB57B	5	BDQ60	C
AH14	PB58A	5	BDQ60	T
AG12	PB58B	5	BDQ60	C
VCCIO	VCCIO5	5		
AG15	PB59A	5	BDQ60	T
AG13	PB59B	5	BDQ60	C
GNDIO	GNDIO5	-		
AF16	PB60A	5	BDQS60	T
AH15	PB60B	5	BDQ60	C
AC16	PB61A	5	VREF2_5/BDQ60	T
AE16	PB61B	5	VREF1_5/BDQ60	C
AG11	PB62A	5	PCLKT5_0/BDQ60	T
AF11	PB62B	5	PCLKC5_0/BDQ60	C
VCCIO	VCCIO5	5		
GNDIO	GNDIO5	-		
AJ14	PB67A	4	PCLKT4_0/BDQ69	T
VCCIO	VCCIO4	4		
AK14	PB67B	4	PCLKC4_0/BDQ69	C
AK15	PB68A	4	VREF2_4/BDQ69	T
AK16	PB68B	4	VREF1_4/BDQ69	C
AF18	PB69A	4	BDQS69	T
GNDIO	GNDIO4	-		
AD16	PB69B	4	BDQ69	C
AJ15	PB70A	4	BDQ69	T
AG16	PB70B	4	BDQ69	C
AE17	PB71A	4	BDQ69	T
VCCIO	VCCIO4	4		
AC17	PB71B	4	BDQ69	C
AH16	PB72A	4	BDQ69	T
AK17	PB72B	4	BDQ69	C
AG20	PB73A	4	BDQ69	T
GNDIO	GNDIO4	-		
AG21	PB73B	4	BDQ69	C
AG18	PB74A	4	BDQ78	T
AJ16	PB74B	4	BDQ78	C
AF21	PB75A	4	BDQ78	T
AG22	PB75B	4	BDQ78	C
AD17	PB76A	4	BDQ78	T
AF19	PB76B	4	BDQ78	C
VCCIO	VCCIO4	4		
GNDIO	GNDIO4	-		
AH17	PB80A	4	BDQ78	T
AJ17	PB80B	4	BDQ78	C

LFE2M100E/SE Logic Signal Connections: 900 fpBGA (Cont.)

LFE2M100E/SE				
Ball Number	Ball/Pad Function	Bank	Dual Function	Differential
VCCIO	VCCIO4	4		
AF26	PB82A	4	BDQ78	T
AE25	PB82B	4	BDQ78	C
GNDIO	GNDIO4	-		
AD24	PB92A	4	BDQ96	T
AE24	PB92B	4	BDQ96	C
AD18	PB93A	4	BDQ96	T
AC18	PB93B	4	BDQ96	C
AE18	PB94A	4	BDQ96	T
AG19	PB94B	4	BDQ96	C
VCCIO	VCCIO4	4		
GNDIO	GNDIO4	-		
AC19	PB96A	4	BDQS96	T
AD20	PB96B	4	BDQ96	C
AB18	PB97A	4	BDQ96	T
AC20	PB97B	4	BDQ96	C
AE20	PB98A	4	BDQ96	T
AE21	PB98B	4	BDQ96	C
VCCIO	VCCIO4	4		
AC23	PB99A	4	BDQ96	T
AD23	PB99B	4	BDQ96	C
GNDIO	GNDIO4	-		
AH18	LRC_SQ_VCCR3	13		
AK19	LRC_SQ_HDINP3	13		T
AJ18	LRC_SQ_VCCIB3	13		
AJ19	LRC_SQ_HDINN3	13		C
AH21	LRC_SQ_VCCTX3	13		
AK22	LRC_SQ_HDOUTP3	13		T
AK21	LRC_SQ_VCCOB3	13		
AJ22	LRC_SQ_HDOUTN3	13		C
AH22	LRC_SQ_VCCTX2	13		
AJ23	LRC_SQ_HDOUTN2	13		C
AH23	LRC_SQ_VCCOB2	13		
AK23	LRC_SQ_HDOUTP2	13		T
AH19	LRC_SQ_VCCR2	13		
AJ20	LRC_SQ_HDINN2	13		C
AH20	LRC_SQ_VCCIB2	13		
AK20	LRC_SQ_HDINP2	13		T
AH24	LRC_SQ_VCCP	13		
AG24	LRC_SQ_REFCLKP	13		T
AF24	LRC_SQ_REFCLKN	13		C
AJ24	LRC_SQ_VCCAUX33	13		
AK28	LRC_SQ_HDINP1	13		T

LFE2M100E/SE Logic Signal Connections: 900 fpBGA (Cont.)

LFE2M100E/SE				
Ball Number	Ball/Pad Function	Bank	Dual Function	Differential
AH28	LRC_SQ_VCCIB1	13		
AJ28	LRC_SQ_HDINN1	13		C
AH29	LRC_SQ_VCCR1	13		
AK25	LRC_SQ_HDOUTP1	13		T
AH25	LRC_SQ_VCCOB1	13		
AJ25	LRC_SQ_HDOUTN1	13		C
AH26	LRC_SQ_VCCTX1	13		
AJ26	LRC_SQ_HDOUTN0	13		C
AK27	LRC_SQ_VCCOB0	13		
AK26	LRC_SQ_HDOUTP0	13		T
AH27	LRC_SQ_VCCTX0	13		
AJ29	LRC_SQ_HDINN0	13		C
AJ30	LRC_SQ_VCCIB0	13		
AK29	LRC_SQ_HDINP0	13		T
AH30	LRC_SQ_VCCR0	13		
AG27	CFG2	8		
AD25	CFG1	8		
AG28	CFG0	8		
AG30	PROGRAMN	8		
AG29	CCLK	8		
AC24	INITN	8		
AF27	DONE	8		
GNDIO	GNDIO8	-		
AF28	WRITEN***	8		
AE26	CS1N***	8		
AB23	CSN***	8		
AF29	D0/SPIFASTN***	8		
VCCIO	VCCIO8	8		
AF30	D1***	8		
AD26	D2***	8		
AE29	D3***	8		
GNDIO	GNDIO8	-		
AE30	D4***	8		
AD29	D5***	8		
AC25	D6***	8		
AD30	D7***	8		
VCCIO	VCCIO8	8		
AA22	DI/CSSPI0N***	8		
AC26	DOUT/CSON/CSSPI1N***	8		
AA23	BUSY/SISPI***	8		
AB22	RLM0_PLLCAP	3		
AC27	PR102B	3	RLM0_GDLLC_FB_A/RDQ99	C
GNDIO	GNDIO3	-		

LFE2M100E/SE Logic Signal Connections: 900 fpBGA (Cont.)

LFE2M100E/SE				
Ball Number	Ball/Pad Function	Bank	Dual Function	Differential
AC28	PR102A	3	RLM0_GDLLT_FB_A/RDQ99	T
AC29	PR101B	3	RLM0_GDLLC_IN_A**/RDQ99	C (LVDS)*
AC30	PR101A	3	RLM0_GDLLT_IN_A**/RDQ99	T (LVDS)*
AB30	PR100B	3	RLM0_GPLLC_IN_A**/RDQ99	C
VCCIO	VCCIO3	3		
AA30	PR100A	3	RLM0_GPLLT_IN_A**/RDQ99	T
AB29	PR99B	3	RLM0_GPLLC_FB_A/RDQ99	C (LVDS)*
AB28	PR99A	3	RLM0_GPLLT_FB_A/RDQS99	T (LVDS)*
GNDIO	GNDIO3	-		
Y22	PR98B	3	RDQ99	C
Y23	PR98A	3	RDQ99	T
AB26	PR97B	3	RDQ99	C (LVDS)*
AB27	PR97A	3	RDQ99	T (LVDS)*
VCCIO	VCCIO3	3		
Y24	PR96B	3	RDQ99	C
Y25	PR96A	3	RDQ99	T
AA29	PR95B	3	RDQ99	C (LVDS)*
Y28	PR95A	3	RDQ99	T (LVDS)*
Y30	PR93B	3	RDQ90	C
Y29	PR93A	3	RDQ90	T
GNDIO	GNDIO3	-		
VCCIO	VCCIO3	3		
W22	PR83B	3	RDQ81	C (LVDS)*
V22	PR83A	3	RDQ81	T (LVDS)*
Y27	PR82B	3	RDQ81	C
VCCIO	VCCIO3	3		
Y26	PR82A	3	RDQ81	T
W30	PR81B	3	RDQ81	C (LVDS)*
W29	PR81A	3	RDQS81	T (LVDS)*
GNDIO	GNDIO3	-		
W25	PR80B	3	RDQ81	C
W26	PR80A	3	RDQ81	T
U29	PR79B	3	RDQ81	C (LVDS)*
V29	PR79A	3	RDQ81	T (LVDS)*
VCCIO	VCCIO3	3		
V30	PR78B	3	RDQ81	C
U30	PR78A	3	RDQ81	T
W27	PR77B	3	RDQ81	C (LVDS)*
W28	PR77A	3	RDQ81	T (LVDS)*
V24	PR75B	3	RDQ72	C
V25	PR75A	3	RDQ72	T
GNDIO	GNDIO3	-		
U28	PR74B	3	RDQ72	C (LVDS)*

LFE2M100E/SE Logic Signal Connections: 900 fpBGA (Cont.)

LFE2M100E/SE				
Ball Number	Ball/Pad Function	Bank	Dual Function	Differential
U27	PR74A	3	RDQ72	T (LVDS)*
U23	PR73B	3	RDQ72	C
V23	PR73A	3	RDQ72	T
VCCIO	VCCIO3	3		
V26	PR72B	3	RDQ72	C (LVDS)*
U26	PR72A	3	RDQS72	T (LVDS)*
U25	PR71B	3	RDQ72	C
GNDIO	GNDIO3	-		
U24	PR71A	3	RDQ72	T
T30	PR70B	3	RDQ72	C (LVDS)*
R30	PR70A	3	RDQ72	T (LVDS)*
T23	PR69B	3	RDQ72	C
VCCIO	VCCIO3	3		
T22	PR69A	3	RDQ72	T
T29	PR68B	3	RDQ72	C (LVDS)*
T28	PR68A	3	RDQ72	T (LVDS)*
R23	PR66B	3	RLM4_SPLLC_FB_A/RDQ63	C
GNDIO	GNDIO3	-		
-	-	-		
R22	PR66A	3	RLM4_SPLLT_FB_A/RDQ63	T
P30	PR65B	3	RLM4_SPLLC_IN_A/RDQ63	C (LVDS)*
R29	PR65A	3	RLM4_SPLLT_IN_A/RDQ63	T (LVDS)*
T27	PR64B	3	RDQ63	C
VCCIO	VCCIO3	3		
T26	PR64A	3	RDQ63	T
GNDIO	GNDIO3	-		
N30	PR61B	3	RDQ63	C (LVDS)*
N29	PR61A	3	RDQ63	T (LVDS)*
VCCIO	VCCIO3	3		
R27	PR60B	3	VREF2_3/RDQ63	C
R28	PR60A	3	VREF1_3/RDQ63	T
P29	PR59B	3	PCLKC3_0/RDQ63	C (LVDS)*
P28	PR59A	3	PCLKT3_0/RDQ63	T (LVDS)*
M30	PR57B	2	PCLKC2_0/RDQ54	C
M29	PR57A	2	PCLKT2_0/RDQ54	T
GNDIO	GNDIO2	-		
P23	PR56B	2	RDQ54	C (LVDS)*
P24	PR56A	2	RDQ54	T (LVDS)*
R26	PR55B	2	RDQ54	C
P27	PR55A	2	RDQ54	T
VCCIO	VCCIO2	2		
P25	PR54B	2	RDQ54	C (LVDS)*
P26	PR54A	2	RDQS54	T (LVDS)*

LFE2M100E/SE Logic Signal Connections: 900 fpBGA (Cont.)

LFE2M100E/SE				
Ball Number	Ball/Pad Function	Bank	Dual Function	Differential
K30	PR53B	2	RDQ54	C
GNDIO	GNDIO2	-		
K29	PR53A	2	RDQ54	T
N22	PR52B	2	RDQ54	C (LVDS)*
P22	PR52A	2	RDQ54	T (LVDS)*
J30	PR51B	2	RUM3_SPLLC_FB_A/RDQ54	C
VCCIO	VCCIO2	2		
J29	PR51A	2	RUM3_SPLLT_FB_A/RDQ54	T
N24	PR50B	2	RUM3_SPLLC_IN_A/RDQ54	C (LVDS)*
N23	PR50A	2	RUM3_SPLLT_IN_A/RDQ54	T (LVDS)*
N25	PR48B	2	RDQ45	C
N26	PR48A	2	RDQ45	T
GNDIO	GNDIO2	-		
M27	PR47B	2	RDQ45	C (LVDS)*
M28	PR47A	2	RDQ45	T (LVDS)*
H30	PR46B	2	RDQ45	C
G30	PR46A	2	RDQ45	T
VCCIO	VCCIO2	2		
M25	PR45B	2	RDQ45	C (LVDS)*
M26	PR45A	2	RDQS45	T (LVDS)*
L30	PR44B	2	RDQ45	C
GNDIO	GNDIO2	-		
L29	PR44A	2	RDQ45	T
L28	PR43B	2	RDQ45	C (LVDS)*
L27	PR43A	2	RDQ45	T (LVDS)*
H29	PR42B	2	RDQ45	C
VCCIO	VCCIO2	2		
G29	PR42A	2	RDQ45	T
L22	PR41B	2	RDQ45	C (LVDS)*
M22	PR41A	2	RDQ45	T (LVDS)*
F30	PR40B	2		C
GNDIO	GNDIO2	-		
F29	PR40A	2		T
VCCIO	VCCIO2	2		
GNDIO	GNDIO2	-		
E30	PR34B	2	RDQ32	C (LVDS)*
E29	PR34A	2	RDQ32	T (LVDS)*
-	-	-		
L25	PR33B	2	RDQ32	C
L26	PR33A	2	RDQ32	T
VCCIO	VCCIO2	2		
H28	PR32B	2	RDQ32	C (LVDS)*
J28	PR32A	2	RDQS32	T (LVDS)*

LFE2M100E/SE Logic Signal Connections: 900 fpBGA (Cont.)

LFE2M100E/SE				
Ball Number	Ball/Pad Function	Bank	Dual Function	Differential
G28	PR31B	2	RDQ32	C
GNDIO	GNDIO2	-		
G27	PR31A	2	RDQ32	T
L24	PR30B	2	RDQ32	C (LVDS)*
L23	PR30A	2	RDQ32	T (LVDS)*
D30	PR29B	2	RDQ32	C
VCCIO	VCCIO2	2		
D29	PR29A	2	RDQ32	T
K24	PR28B	2	RDQ32	C (LVDS)*
K25	PR28A	2	RDQ32	T (LVDS)*
J27	PR26B	2	RDQ23	C
GNDIO	GNDIO2	-		
K26	PR26A	2	RDQ23	T
K23	PR25B	2	RDQ23	C (LVDS)*
K22	PR25A	2	RDQ23	T (LVDS)*
J22	PR24B	2	RDQ23	C
VCCIO	VCCIO2	2		
J23	PR24A	2	RDQ23	T
GNDIO	GNDIO2	-		
VCCIO	VCCIO2	2		
J26	PR17B	2	RDQ15	C (LVDS)*
H26	PR17A	2	RDQ15	T (LVDS)*
H27	PR16B	2	RDQ15	C
G26	PR16A	2	RDQ15	T
VCCIO	VCCIO2	2		
H23	PR15B	2	RDQ15	C (LVDS)*
H24	PR15A	2	RDQS15	T (LVDS)*
D28	PR14B	2	RDQ15	C
GNDIO	GNDIO2	-		
E28	PR14A	2	RDQ15	T
G24	PR13B	2	RDQ15	C (LVDS)*
H25	PR13A	2	RDQ15	T (LVDS)*
D27	PR12B	2	RUM0_SPLLC_FB_A/RDQ15	C
VCCIO	VCCIO2	2		
E27	PR12A	2	RUM0_SPLLT_FB_A/RDQ15	T
F26	PR11B	2	RUM0_SPLLC_IN_A/RDQ15	C (LVDS)*
G25	PR11A	2	RUM0_SPLLT_IN_A/RDQ15	T (LVDS)*
F24	PR9B	2	VREF2_2	C
-	-	-		
GNDIO	GNDIO2	-		
F25	PR9A	2	VREF1_2	T
VCCIO	VCCIO2	2		
G23	XRES	1		

LFE2M100E/SE Logic Signal Connections: 900 fpBGA (Cont.)

LFE2M100E/SE				
Ball Number	Ball/Pad Function	Bank	Dual Function	Differential
C30	URC_SQ_VCCR0	12		
A29	URC_SQ_HDINP0	12		T
B30	URC_SQ_VCCIB0	12		
B29	URC_SQ_HDINN0	12		C
C27	URC_SQ_VCCTX0	12		
A26	URC_SQ_HDOUTP0	12		T
A27	URC_SQ_VCCOB0	12		
B26	URC_SQ_HDOUTN0	12		C
C26	URC_SQ_VCCTX1	12		
B25	URC_SQ_HDOUTN1	12		C
C25	URC_SQ_VCCOB1	12		
A25	URC_SQ_HDOUTP1	12		T
C29	URC_SQ_VCCR1	12		
B28	URC_SQ_HDINN1	12		C
C28	URC_SQ_VCCIB1	12		
A28	URC_SQ_HDINP1	12		T
B24	URC_SQ_VCCAUX33	12		
E24	URC_SQ_REFCLKN	12		C
D24	URC_SQ_REFCLKP	12		T
C24	URC_SQ_VCCP	12		
A20	URC_SQ_HDINP2	12		T
C20	URC_SQ_VCCIB2	12		
B20	URC_SQ_HDINN2	12		C
C19	URC_SQ_VCCR2	12		
A23	URC_SQ_HDOUTP2	12		T
C23	URC_SQ_VCCOB2	12		
B23	URC_SQ_HDOUTN2	12		C
C22	URC_SQ_VCCTX2	12		
B22	URC_SQ_HDOUTN3	12		C
A21	URC_SQ_VCCOB3	12		
A22	URC_SQ_HDOUTP3	12		T
C21	URC_SQ_VCCTX3	12		
B19	URC_SQ_HDINN3	12		C
B18	URC_SQ_VCCIB3	12		
A19	URC_SQ_HDINP3	12		T
C18	URC_SQ_VCCR3	12		
D23	PT100B	1		C
GNDIO	GNDIO1	-		
E21	PT100A	1		T
D26	PT99B	1		C
E26	PT99A	1		T
E23	PT98B	1		C
VCCIO	VCCIO1	1		

LFE2M100E/SE Logic Signal Connections: 900 fpBGA (Cont.)

LFE2M100E/SE				
Ball Number	Ball/Pad Function	Bank	Dual Function	Differential
G22	PT98A	1		T
-	-	-		
D22	PT97B	1		C
F21	PT97A	1		T
G18	PT96B	1		C
H18	PT96A	1		T
D20	PT95B	1		C
GNDIO	GNDIO1	-		
D21	PT95A	1		T
E20	PT94B	1		C
VCCIO	VCCIO1	1		
E19	PT94A	1		T
D19	PT93B	1		C
E18	PT93A	1		T
D18	PT92B	1		C
C17	PT92A	1		T
A17	PT91B	1		C
B17	PT91A	1		T
GNDIO	GNDIO1	-		
VCCIO	VCCIO1	1		
J18	PT75B	1		C
J19	PT75A	1		T
H17	PT74B	1		C
J17	PT74A	1		T
F18	PT73B	1		C
F17	PT73A	1		T
GNDIO	GNDIO1	-		
A16	PT72B	1		C
B16	PT72A	1		T
G17	PT71B	1		C
G16	PT71A	1		T
VCCIO	VCCIO1	1		
H16	PT70B	1		C
F16	PT70A	1		T
J16	PT69B	1		C
G15	PT69A	1		T
GNDIO	GNDIO1	-		
C16	PT68B	1		C
D16	PT68A	1		T
J15	PT67B	1		C
H15	PT67A	1		T
VCCIO	VCCIO1	1		
A15	PT66B	1	VREF2_1	C

LFE2M100E/SE Logic Signal Connections: 900 fpBGA (Cont.)

LFE2M100E/SE				
Ball Number	Ball/Pad Function	Bank	Dual Function	Differential
B15	PT66A	1	VREF1_1	T
F15	PT65B	1	PCLKC1_0	C
E16	PT65A	1	PCLKT1_0	T
C15	PT64B	0	PCLKC0_0	C
GNDIO	GNDIO0	-		
D15	PT64A	0	PCLKT0_0	T
C14	PT63B	0	VREF2_0	C
E15	PT63A	0	VREF1_0	T
G14	PT62B	0		C
VCCIO	VCCIO0	0		
J14	PT62A	0		T
F14	PT61B	0		C
H14	PT61A	0		T
A14	PT60B	0		C
B14	PT60A	0		T
D13	PT59B	0		C
GNDIO	GNDIO0	-		
F13	PT59A	0		T
G13	PT58B	0		C
VCCIO	VCCIO0	0		
J11	PT58A	0		T
D4	PT57B	0		
D5	PT56A	0		
E5	PT55B	0		C
F6	PT55A	0		T
GNDIO	GNDIO0	-		
VCCIO	VCCIO0	0		
F7	PT52B	0		C
D8	PT52A	0		T
GNDIO	GNDIO0	-		
J13	PT50B	0		C
G11	PT50A	0		T
H13	PT49B	0		C
H12	PT49A	0		T
VCCIO	VCCIO0	0		
E8	PT48B	0		C
D9	PT48A	0		T
D12	PT46B	0		C
GNDIO	GNDIO0	-		
E13	PT46A	0		T
VCCIO	VCCIO0	0		
GNDIO	GNDIO0	-		
J12	PT31B	0		C

LFE2M100E/SE Logic Signal Connections: 900 fpBGA (Cont.)

LFE2M100E/SE				
Ball Number	Ball/Pad Function	Bank	Dual Function	Differential
-	-	-		
VCCIO	VCCIO0	0		
H10	PT31A	0		T
E12	PT30B	0		C
D11	PT30A	0		T
H11	PT29B	0		C
F11	PT29A	0		T
C13	ULC_SQ_VCCR0	11		
A12	ULC_SQ_HDINP0	11		T
B13	ULC_SQ_VCCIB0	11		
B12	ULC_SQ_HDINN0	11		C
C10	ULC_SQ_VCCTX0	11		
A9	ULC_SQ_HDOUPT0	11		T
A10	ULC_SQ_VCCOB0	11		
B9	ULC_SQ_HDOUTN0	11		C
C9	ULC_SQ_VCCTX1	11		
B8	ULC_SQ_HDOUTN1	11		C
C8	ULC_SQ_VCCOB1	11		
A8	ULC_SQ_HDOUPT1	11		T
C12	ULC_SQ_VCCR1	11		
B11	ULC_SQ_HDINN1	11		C
C11	ULC_SQ_VCCIB1	11		
A11	ULC_SQ_HDINP1	11		T
B7	ULC_SQ_VCCAUX33	11		
E7	ULC_SQ_REFCLKN	11		C
D7	ULC_SQ_REFCLKP	11		T
C7	ULC_SQ_VCCP	11		
A3	ULC_SQ_HDINP2	11		T
C3	ULC_SQ_VCCIB2	11		
B3	ULC_SQ_HDINN2	11		C
C2	ULC_SQ_VCCR2	11		
A6	ULC_SQ_HDOUPT2	11		T
C6	ULC_SQ_VCCOB2	11		
B6	ULC_SQ_HDOUTN2	11		C
C5	ULC_SQ_VCCTX2	11		
B5	ULC_SQ_HDOUTN3	11		C
A4	ULC_SQ_VCCOB3	11		
A5	ULC_SQ_HDOUPT3	11		T
C4	ULC_SQ_VCCTX3	11		
B2	ULC_SQ_HDINN3	11		C
B1	ULC_SQ_VCCIB3	11		
A2	ULC_SQ_HDINP3	11		T
C1	ULC_SQ_VCCR3	11		

LFE2M100E/SE Logic Signal Connections: 900 fpBGA (Cont.)

LFE2M100E/SE				
Ball Number	Ball/Pad Function	Bank	Dual Function	Differential
L12	VCC	-		
L13	VCC	-		
L18	VCC	-		
L19	VCC	-		
M11	VCC	-		
M12	VCC	-		
M13	VCC	-		
M14	VCC	-		
M15	VCC	-		
M16	VCC	-		
M17	VCC	-		
M18	VCC	-		
M19	VCC	-		
M20	VCC	-		
N11	VCC	-		
N12	VCC	-		
N19	VCC	-		
N20	VCC	-		
P12	VCC	-		
P19	VCC	-		
R12	VCC	-		
R19	VCC	-		
T12	VCC	-		
T19	VCC	-		
U12	VCC	-		
U19	VCC	-		
V11	VCC	-		
V12	VCC	-		
V19	VCC	-		
V20	VCC	-		
W11	VCC	-		
W12	VCC	-		
W13	VCC	-		
W14	VCC	-		
W15	VCC	-		
W16	VCC	-		
W17	VCC	-		
W18	VCC	-		
W19	VCC	-		
W20	VCC	-		
Y12	VCC	-		
Y13	VCC	-		
Y18	VCC	-		

LFE2M100E/SE Logic Signal Connections: 900 fpBGA (Cont.)

LFE2M100E/SE				
Ball Number	Ball/Pad Function	Bank	Dual Function	Differential
Y19	VCC	-		
D14	VCCIO0	0		
E6	VCCIO0	0		
E9	VCCIO0	0		
F12	VCCIO0	0		
K12	VCCIO0	0		
K13	VCCIO0	0		
D17	VCCIO1	1		
E22	VCCIO1	1		
E25	VCCIO1	1		
F19	VCCIO1	1		
K18	VCCIO1	1		
K19	VCCIO1	1		
F28	VCCIO2	2		
J25	VCCIO2	2		
K28	VCCIO2	2		
M21	VCCIO2	2		
M24	VCCIO2	2		
N21	VCCIO2	2		
N28	VCCIO2	2		
P21	VCCIO2	2		
R25	VCCIO2	2		
AA28	VCCIO3	3		
AB25	VCCIO3	3		
AE28	VCCIO3	3		
T25	VCCIO3	3		
U21	VCCIO3	3		
V21	VCCIO3	3		
V28	VCCIO3	3		
W21	VCCIO3	3		
W24	VCCIO3	3		
AA18	VCCIO4	4		
AA19	VCCIO4	4		
AE19	VCCIO4	4		
AF22	VCCIO4	4		
AG17	VCCIO4	4		
AG25	VCCIO4	4		
AA12	VCCIO5	5		
AA13	VCCIO5	5		
AE12	VCCIO5	5		
AF9	VCCIO5	5		
AG14	VCCIO5	5		
AG6	VCCIO5	5		

LFE2M100E/SE Logic Signal Connections: 900 fpBGA (Cont.)

LFE2M100E/SE				
Ball Number	Ball/Pad Function	Bank	Dual Function	Differential
AA3	VCCIO6	6		
AB6	VCCIO6	6		
AE3	VCCIO6	6		
T6	VCCIO6	6		
U10	VCCIO6	6		
V10	VCCIO6	6		
V3	VCCIO6	6		
W10	VCCIO6	6		
W7	VCCIO6	6		
F3	VCCIO7	7		
J6	VCCIO7	7		
K3	VCCIO7	7		
M10	VCCIO7	7		
M7	VCCIO7	7		
N10	VCCIO7	7		
N3	VCCIO7	7		
P10	VCCIO7	7		
R6	VCCIO7	7		
AA25	VCCIO8	8		
AD28	VCCIO8	8		
AA10	VCCAUX	-		
AA11	VCCAUX	-		
AA20	VCCAUX	-		
AA21	VCCAUX	-		
K10	VCCAUX	-		
K11	VCCAUX	-		
K20	VCCAUX	-		
K21	VCCAUX	-		
L10	VCCAUX	-		
L11	VCCAUX	-		
L20	VCCAUX	-		
L21	VCCAUX	-		
Y10	VCCAUX	-		
Y11	VCCAUX	-		
Y20	VCCAUX	-		
Y21	VCCAUX	-		
A1	GND	-		
A13	GND	-		
A18	GND	-		
A24	GND	-		
A30	GND	-		
A7	GND	-		
AA14	GND	-		

LFE2M100E/SE Logic Signal Connections: 900 fpBGA (Cont.)

LFE2M100E/SE				
Ball Number	Ball/Pad Function	Bank	Dual Function	Differential
AA15	GND	-		
AA16	GND	-		
AA17	GND	-		
AA24	GND	-		
AA27	GND	-		
AA4	GND	-		
AB24	GND	-		
AB7	GND	-		
AD12	GND	-		
AD19	GND	-		
AD27	GND	-		
AE22	GND	-		
AE27	GND	-		
AE4	GND	-		
AE9	GND	-		
AF14	GND	-		
AF17	GND	-		
AF25	GND	-		
AF6	GND	-		
AJ10	GND	-		
AJ21	GND	-		
AJ27	GND	-		
AJ4	GND	-		
AK1	GND	-		
AK13	GND	-		
AK18	GND	-		
AK24	GND	-		
AK30	GND	-		
AK7	GND	-		
B10	GND	-		
B21	GND	-		
B27	GND	-		
B4	GND	-		
D25	GND	-		
D6	GND	-		
E14	GND	-		
E17	GND	-		
F22	GND	-		
F27	GND	-		
F4	GND	-		
F9	GND	-		
G12	GND	-		
G19	GND	-		

LFE2M100E/SE Logic Signal Connections: 900 fpBGA (Cont.)

LFE2M100E/SE				
Ball Number	Ball/Pad Function	Bank	Dual Function	Differential
J24	GND	-		
J7	GND	-		
K14	GND	-		
K15	GND	-		
K16	GND	-		
K17	GND	-		
K27	GND	-		
K4	GND	-		
L14	GND	-		
L15	GND	-		
L16	GND	-		
L17	GND	-		
M23	GND	-		
M8	GND	-		
N14	GND	-		
N15	GND	-		
N16	GND	-		
N17	GND	-		
N27	GND	-		
N4	GND	-		
P11	GND	-		
P13	GND	-		
P14	GND	-		
P15	GND	-		
P16	GND	-		
P17	GND	-		
P18	GND	-		
P20	GND	-		
R10	GND	-		
R11	GND	-		
R13	GND	-		
R14	GND	-		
R15	GND	-		
R16	GND	-		
R17	GND	-		
R18	GND	-		
R20	GND	-		
R21	GND	-		
R24	GND	-		
R7	GND	-		
T10	GND	-		
T11	GND	-		
T13	GND	-		

LFE2M100E/SE Logic Signal Connections: 900 fpBGA (Cont.)

LFE2M100E/SE				
Ball Number	Ball/Pad Function	Bank	Dual Function	Differential
T14	GND	-		
T15	GND	-		
T16	GND	-		
T17	GND	-		
T18	GND	-		
T20	GND	-		
T21	GND	-		
T24	GND	-		
T7	GND	-		
U11	GND	-		
U13	GND	-		
U14	GND	-		
U15	GND	-		
U16	GND	-		
U17	GND	-		
U18	GND	-		
U20	GND	-		
V14	GND	-		
V15	GND	-		
V16	GND	-		
V17	GND	-		
V27	GND	-		
V4	GND	-		
W23	GND	-		
W8	GND	-		
Y14	GND	-		
Y15	GND	-		
Y16	GND	-		
Y17	GND	-		
AA26	NC	-		
AB10	NC	-		
AB11	NC	-		
AB12	NC	-		
AB13	NC	-		
AB14	NC	-		
AB15	NC	-		
AB16	NC	-		
AB17	NC	-		
AB19	NC	-		
AB20	NC	-		
AB21	NC	-		
AB9	NC	-		
AC10	NC	-		

LFE2M100E/SE Logic Signal Connections: 900 fpBGA (Cont.)

LFE2M100E/SE				
Ball Number	Ball/Pad Function	Bank	Dual Function	Differential
AC11	NC	-		
AC21	NC	-		
AC22	NC	-		
AC8	NC	-		
AC9	NC	-		
AD21	NC	-		
AD22	NC	-		
AD4	NC	-		
AD5	NC	-		
AD6	NC	-		
AD7	NC	-		
AD8	NC	-		
AE23	NC	-		
AE5	NC	-		
AE6	NC	-		
AE7	NC	-		
AF20	NC	-		
AF23	NC	-		
AF5	NC	-		
AG23	NC	-		
AG26	NC	-		
D10	NC	-		
E10	NC	-		
E11	NC	-		
F10	NC	-		
F20	NC	-		
F23	NC	-		
F8	NC	-		
G10	NC	-		
G20	NC	-		
G21	NC	-		
G7	NC	-		
G8	NC	-		
G9	NC	-		
H19	NC	-		
H20	NC	-		
H21	NC	-		
H22	NC	-		
H6	NC	-		
H8	NC	-		
H9	NC	-		
J10	NC	-		
J20	NC	-		

LFE2M100E/SE Logic Signal Connections: 900 fpBGA (Cont.)

LFE2M100E/SE				
Ball Number	Ball/Pad Function	Bank	Dual Function	Differential
J21	NC	-		
J9	NC	-		
K9	NC	-		
R9	NC	-		
U22	NC	-		
W9	NC	-		
N13	VCCPLL	-		
N18	VCCPLL	-		
V13	VCCPLL	-		
V18	VCCPLL	-		

* Supports true LVDS. Other differential signals must be emulated with external resistors.

** These dedicated input pins can be used for GPLLs or GDLLs within the respective quadrant.

*** These sysCONFIG pins are dedicated I/O pins for configuration. The outputs are actively driven during normal device operation.

****Due to packaging bond out option, this DQS does not have all the necessary DQ pins bonded out for a full 8-bit data width.

Note: VCCIO and GND pads are used to determine the average DC current drawn by I/Os between GND/VCCIO connections, or between the last GND/VCCIO in an I/O bank and the end of an I/O bank. The substrate pads listed in the Pin Table do not necessarily have a one to one connection with a package ball or pin.

LFE2M70E/SE and LFE2M100E/SE Logic Signal Connections: 1152 fpBGA

LFE2M70E/SE				LFE2M100E/SE				
Ball Number	Ball/Pad Function	Bank	Dual Function	Differential	Ball/Pad Function	Bank	Dual Function	Differential
VCCIO	VCCIO7	7			VCCIO7	7		
F4	PL9A	7	VREF2_7	T	PL9A	7	VREF2_7	T
F3	PL9B	7	VREF1_7	C	PL9B	7	VREF1_7	C
GNDIO	GNDIO7	-			GNDIO7	-		
E1	PL11A	7	LUM0_SPLLT_IN_A/LDQ15	T (LVDS)*	PL11A	7	LUM0_SPLLT_IN_A/LDQ15	T (LVDS)*
E2	PL11B	7	LUM0_SPLLC_IN_A/LDQ15	C (LVDS)*	PL11B	7	LUM0_SPLLC_IN_A/LDQ15	C (LVDS)*
K9	PL12A	7	LUM0_SPLLT_FB_A/LDQ15	T	PL12A	7	LUM0_SPLLT_FB_A/LDQ15	T
H7	PL12B	7	LUM0_SPLLC_FB_A/LDQ15	C	PL12B	7	LUM0_SPLLC_FB_A/LDQ15	C
VCCIO	VCCIO7	7			VCCIO7	7		
F1	PL13A	7	LDQ15	T (LVDS)*	PL13A	7	LDQ15	T (LVDS)*
F2	PL13B	7	LDQ15	C (LVDS)*	PL13B	7	LDQ15	C (LVDS)*
J8	PL14A	7	LDQ15	T	PL14A	7	LDQ15	T
H6	PL14B	7	LDQ15	C	PL14B	7	LDQ15	C
GNDIO	GNDIO7	-			GNDIO7	-		
G2	PL15A	7	LDQS15	T (LVDS)*	PL15A	7	LDQS15	T (LVDS)*
G1	PL15B	7	LDQ15	C (LVDS)*	PL15B	7	LDQ15	C (LVDS)*
J7	PL16A	7	LDQ15	T	PL16A	7	LDQ15	T
VCCIO	VCCIO7	7			VCCIO7	7		
L8	PL16B	7	LDQ15	C	PL16B	7	LDQ15	C
L9	PL17A	7	LDQ15	T (LVDS)*	PL17A	7	LDQ15	T (LVDS)*
L10	PL17B	7	LDQ15	C (LVDS)*	PL17B	7	LDQ15	C (LVDS)*
H5	PL18A	7	LDQ15	T	PL18A	7	LDQ15	T
GNDIO	GNDIO7	-			GNDIO7	-		
J6	PL18B	7	LDQ15	C	PL18B	7	LDQ15	C
H2	NC	-			PL19A	7	LDQ23	T (LVDS)*
H1	NC	-			PL19B	7	LDQ23	C (LVDS)*
G5	NC	-			PL20A	7	LDQ23	T
G6	NC	-			PL20B	7	LDQ23	C
M9	NC	-			PL21A	7	LDQ23	T (LVDS)*
-	-	-			VCCIO7	7		
M10	NC	-			PL21B	7	LDQ23	C (LVDS)*
H3	NC	-			PL22A	7	LDQ23	T
H4	NC	-			PL22B	7	LDQ23	C
J2	PL19A	7		T (LVDS)*	PL23A	7	LDQS23	T (LVDS)*
-	-	-			GNDIO7	-		
J1	PL19B	7		C (LVDS)*	PL23B	7	LDQ23	C (LVDS)*
K2	PL20A	7		T	PL24A	7	LDQ23	T
K1	PL20B	7		C	PL24B	7	LDQ23	C
VCCIO	VCCIO7	7			VCCIO7	7		
J4	PL21A	7		T (LVDS)*	PL25A	7	LDQ23	T (LVDS)*
J3	PL21B	7		C (LVDS)*	PL25B	7	LDQ23	C (LVDS)*
J5	PL22A	7		T	PL26A	7	LDQ23	T
K5	PL22B	7		C	PL26B	7	LDQ23	C
GNDIO	GNDIO7	-			GNDIO7	-		
L2	PL24A	7	LDQ28	T (LVDS)*	PL28A	7	LDQ32	T (LVDS)*
L1	PL24B	7	LDQ28	C (LVDS)*	PL28B	7	LDQ32	C (LVDS)*
L7	PL25A	7	LDQ28	T	PL29A	7	LDQ32	T
K6	PL25B	7	LDQ28	C	PL29B	7	LDQ32	C
VCCIO	VCCIO7	7			VCCIO7	7		
M2	PL26A	7	LDQ28	T (LVDS)*	PL30A	7	LDQ32	T (LVDS)*

LFE2M70E/SE and LFE2M100E/SE Logic Signal Connections: 1152 fpBGA

LFE2M70E/SE				LFE2M100E/SE				
Ball Number	Ball/Pad Function	Bank	Dual Function	Differential	Ball/Pad Function	Bank	Dual Function	Differential
M1	PL26B	7	LDQ28	C (LVDS)*	PL30B	7	LDQ32	C (LVDS)*
L6	PL27A	7	LDQ28	T	PL31A	7	LDQ32	T
L5	PL27B	7	LDQ28	C	PL31B	7	LDQ32	C
GNDIO	GNDIO7	-			GNDIO7	-		
L3	PL28A	7	LDQS28	T (LVDS)*	PL32A	7	LDQS32	T (LVDS)*
L4	PL28B	7	LDQ28	C (LVDS)*	PL32B	7	LDQ32	C (LVDS)*
M3	PL29A	7	LDQ28	T	PL33A	7	LDQ32	T
VCCIO	VCCIO7	7			VCCIO7	7		
M4	PL29B	7	LDQ28	C	PL33B	7	LDQ32	C
N1	PL30A	7	LDQ28	T (LVDS)*	PL34A	7	LDQ32	T (LVDS)*
N2	PL30B	7	LDQ28	C (LVDS)*	PL34B	7	LDQ32	C (LVDS)*
M5	PL31A	7	LDQ28	T	PL35A	7	LDQ32	T
GNDIO	GNDIO7	-			GNDIO7	-		
N6	PL31B	7	LDQ28	C	PL35B	7	LDQ32	C
P3	NC	-			PL37A	7		T (LVDS)*
-	-	-			GNDIO7	-		
P4	NC	-			PL37B	7		C (LVDS)*
P9	NC	-			PL38A	7		T
M7	NC	-			PL38B	7		C
-	-	-			VCCIO7	7		
P1	NC	-			PL39A	7		T (LVDS)*
P2	NC	-			PL39B	7		C (LVDS)*
N7	NC	-			PL40A	7		T
P7	NC	-			PL40B	7		C
-	-	-			GNDIO7	-		
P5	PL33A	7	LDQ37	T (LVDS)*	PL41A	7	LDQ45	T (LVDS)*
N5	PL33B	7	LDQ37	C (LVDS)*	PL41B	7	LDQ45	C (LVDS)*
P8	PL34A	7	LDQ37	T	PL42A	7	LDQ45	T
P6	PL34B	7	LDQ37	C	PL42B	7	LDQ45	C
VCCIO	VCCIO7	7			VCCIO7	7		
R3	PL35A	7	LDQ37	T (LVDS)*	PL43A	7	LDQ45	T (LVDS)*
R4	PL35B	7	LDQ37	C (LVDS)*	PL43B	7	LDQ45	C (LVDS)*
R10	PL36A	7	LDQ37	T	PL44A	7	LDQ45	T
P11	PL36B	7	LDQ37	C	PL44B	7	LDQ45	C
GNDIO	GNDIO7	-			GNDIO7	-		
R7	PL37A	7	LDQS37	T (LVDS)*	PL45A	7	LDQS45	T (LVDS)*
R8	PL37B	7	LDQ37	C (LVDS)*	PL45B	7	LDQ45	C (LVDS)*
R5	PL38A	7	LDQ37	T	PL46A	7	LDQ45	T
VCCIO	VCCIO7	7			VCCIO7	7		
T5	PL38B	7	LDQ37	C	PL46B	7	LDQ45	C
R1	PL39A	7	LDQ37	T (LVDS)*	PL47A	7	LDQ45	T (LVDS)*
R2	PL39B	7	LDQ37	C (LVDS)*	PL47B	7	LDQ45	C (LVDS)*
R11	PL40A	7	LDQ37	T	PL48A	7	LDQ45	T
GNDIO	GNDIO7	-			GNDIO7	-		
T10	PL40B	7	LDQ37	C	PL48B	7	LDQ45	C
T1	PL42A	7	LUM3_SPLLT_IN_A/LDQ46	T (LVDS)*	PL50A	7	LUM3_SPLLT_IN_A/LDQ54	T (LVDS)*
T2	PL42B	7	LUM3_SPLLC_IN_A/LDQ46	C (LVDS)*	PL50B	7	LUM3_SPLLC_IN_A/LDQ54	C (LVDS)*
U10	PL43A	7	LUM3_SPLLT_FB_A/LDQ46	T	PL51A	7	LUM3_SPLLT_FB_A/LDQ54	T
U8	PL43B	7	LUM3_SPLLC_FB_A/LDQ46	C	PL51B	7	LUM3_SPLLC_FB_A/LDQ54	C
VCCIO	VCCIO7	7			VCCIO7	7		
T6	PL44A	7	LDQ46	T (LVDS)*	PL52A	7	LDQ54	T (LVDS)*

LFE2M70E/SE and LFE2M100E/SE Logic Signal Connections: 1152 fpBGA

LFE2M70E/SE				LFE2M100E/SE				
Ball Number	Ball/Pad Function	Bank	Dual Function	Differential	Ball/Pad Function	Bank	Dual Function	Differential
R6	PL44B	7	LDQ46	C (LVDS)*	PL52B	7	LDQ54	C (LVDS)*
U9	PL45A	7	LDQ46	T	PL53A	7	LDQ54	T
T7	PL45B	7	LDQ46	C	PL53B	7	LDQ54	C
GNDIO	GNDIO7	-			GNDIO7	-		
U5	PL46A	7	LDQS46	T (LVDS)*	PL54A	7	LDQS54	T (LVDS)*
U6	PL46B	7	LDQ46	C (LVDS)*	PL54B	7	LDQ54	C (LVDS)*
U7	PL47A	7	LDQ46	T	PL55A	7	LDQ54	T
VCCIO	VCCIO7	7			VCCIO7	7		
V9	PL47B	7	LDQ46	C	PL55B	7	LDQ54	C
V11	PL48A	7	LDQ46	T (LVDS)*	PL56A	7	LDQ54	T (LVDS)*
V10	PL48B	7	LDQ46	C (LVDS)*	PL56B	7	LDQ54	C (LVDS)*
U4	PL49A	7	PCLKT7_0/LDQ46	T	PL57A	7	PCLKT7_0/LDQ54	T
GNDIO	GNDIO7	-			GNDIO7	-		
U3	PL49B	7	PCLKC7_0/LDQ46	C	PL57B	7	PCLKC7_0/LDQ54	C
U2	PL51A	6	PCLKT6_0/LDQ55	T (LVDS)*	PL59A	6	PCLKT6_0/LDQ63	T (LVDS)*
U1	PL51B	6	PCLKC6_0/LDQ55	C (LVDS)*	PL59B	6	PCLKC6_0/LDQ63	C (LVDS)*
V5	PL52A	6	VREF2_6/LDQ55	T	PL60A	6	VREF2_6/LDQ63	T
V6	PL52B	6	VREF1_6/LDQ55	C	PL60B	6	VREF1_6/LDQ63	C
V7	PL53A	6	LDQ55	T (LVDS)*	PL61A	6	LDQ63	T (LVDS)*
VCCIO	VCCIO6	6			VCCIO6	6		
V8	PL53B	6	LDQ55	C (LVDS)*	PL61B	6	LDQ63	C (LVDS)*
V4	PL54A	6	LDQ55	T	PL62A	6	LDQ63	T
V3	PL54B	6	LDQ55	C	PL62B	6	LDQ63	C
V2	PL55A	6	LDQS55	T (LVDS)*	PL63A	6	LDQS63	T (LVDS)*
GNDIO	GNDIO6	-			GNDIO6	-		
V1	PL55B	6	LDQ55	C (LVDS)*	PL63B	6	LDQ63	C (LVDS)*
W7	PL56A	6	LDQ55	T	PL64A	6	LDQ63	T
W5	PL56B	6	LDQ55	C	PL64B	6	LDQ63	C
VCCIO	VCCIO6	6			VCCIO6	6		
W2	PL57A	6	LLM3_SPLLT_IN_A/LDQ55	T (LVDS)*	PL65A	6	LLM4_SPLLT_IN_A/LDQ63	T (LVDS)*
W1	PL57B	6	LLM3_SPLLC_IN_A/LDQ55	C (LVDS)*	PL65B	6	LLM4_SPLLC_IN_A/LDQ63	C (LVDS)*
Y6	PL58A	6	LLM3_SPLLT_FB_A/LDQ55	T	PL66A	6	LLM4_SPLLT_FB_A/LDQ63	T
W6	PL58B	6	LLM3_SPLLC_FB_A/LDQ55	C	PL66B	6	LLM4_SPLLC_FB_A/LDQ63	C
GNDIO	GNDIO6	-			GNDIO6	-		
Y1	PL60A	6	LDQ64	T (LVDS)*	PL68A	6	LDQ72	T (LVDS)*
Y2	PL60B	6	LDQ64	C (LVDS)*	PL68B	6	LDQ72	C (LVDS)*
Y7	PL61A	6	LDQ64	T	PL69A	6	LDQ72	T
Y5	PL61B	6	LDQ64	C	PL69B	6	LDQ72	C
VCCIO	VCCIO6	6			VCCIO6	6		
W10	PL62A	6	LDQ64	T (LVDS)*	PL70A	6	LDQ72	T (LVDS)*
Y8	PL62B	6	LDQ64	C (LVDS)*	PL70B	6	LDQ72	C (LVDS)*
Y4	PL63A	6	LDQ64	T	PL71A	6	LDQ72	T
Y3	PL63B	6	LDQ64	C	PL71B	6	LDQ72	C
GNDIO	GNDIO6	-			GNDIO6	-		
AA1	PL64A	6	LDQS64	T (LVDS)*	PL72A	6	LDQS72	T (LVDS)*
AA2	PL64B	6	LDQ64	C (LVDS)*	PL72B	6	LDQ72	C (LVDS)*
AA8	PL65A	6	LDQ64	T	PL73A	6	LDQ72	T
VCCIO	VCCIO6	6			VCCIO6	6		
Y9	PL65B	6	LDQ64	C	PL73B	6	LDQ72	C
AA6	PL66A	6	LDQ64	T (LVDS)*	PL74A	6	LDQ72	T (LVDS)*
AA7	PL66B	6	LDQ64	C (LVDS)*	PL74B	6	LDQ72	C (LVDS)*

LFE2M70E/SE and LFE2M100E/SE Logic Signal Connections: 1152 fpBGA

LFE2M70E/SE				LFE2M100E/SE				
Ball Number	Ball/Pad Function	Bank	Dual Function	Differential	Ball/Pad Function	Bank	Dual Function	Differential
AA4	PL67A	6	LDQ64	T	PL75A	6	LDQ72	T
GNDIO	GNDIO6	-			GNDIO6	-		
AA3	PL67B	6	LDQ64	C	PL75B	6	LDQ72	C
AA9	PL69A	6	LDQ73	T (LVDS)*	PL77A	6	LDQ81	T (LVDS)*
AA10	PL69B	6	LDQ73	C (LVDS)*	PL77B	6	LDQ81	C (LVDS)*
AA5	PL70A	6	LDQ73	T	PL78A	6	LDQ81	T
AB6	PL70B	6	LDQ73	C	PL78B	6	LDQ81	C
AB1	PL71A	6	LDQ73	T (LVDS)*	PL79A	6	LDQ81	T (LVDS)*
VCCIO	VCCIO6	6			VCCIO6	6		
AB2	PL71B	6	LDQ73	C (LVDS)*	PL79B	6	LDQ81	C (LVDS)*
AC8	PL72A	6	LDQ73	T	PL80A	6	LDQ81	T
AB10	PL72B	6	LDQ73	C	PL80B	6	LDQ81	C
AC1	PL73A	6	LDQS73	T (LVDS)*	PL81A	6	LDQS81	T (LVDS)*
GNDIO	GNDIO6	-			GNDIO6	-		
AC2	PL73B	6	LDQ73	C (LVDS)*	PL81B	6	LDQ81	C (LVDS)*
AB7	PL74A	6	LDQ73	T	PL82A	6	LDQ81	T
AB5	PL74B	6	LDQ73	C	PL82B	6	LDQ81	C
VCCIO	VCCIO6	6			VCCIO6	6		
AC3	PL75A	6	LDQ73	T (LVDS)*	PL83A	6	LDQ81	T (LVDS)*
AC4	PL75B	6	LDQ73	C (LVDS)*	PL83B	6	LDQ81	C (LVDS)*
AC10	PL76A	6	LDQ73	T	PL84A	6	LDQ81	T
AC9	PL76B	6	LDQ73	C	PL84B	6	LDQ81	C
GNDIO	GNDIO6	-			GNDIO6	-		
AC7	NC	-			PL86A	6	LDQ90	T (LVDS)*
AC5	NC	-			PL86B	6	LDQ90	C (LVDS)*
AC6	NC	-			PL87A	6	LDQ90	T
AD5	NC	-			PL87B	6	LDQ90	C
-	-	-			VCCIO6	6		
AD4	NC	-			PL88A	6	LDQ90	T (LVDS)*
AD3	NC	-			PL88B	6	LDQ90	C (LVDS)*
AD10	NC	-			PL89A	6	LDQ90	T
AD8	NC	-			PL89B	6	LDQ90	C
-	-	-			GNDIO6	-		
AD2	NC	-			PL90A	6	LDQS90	T (LVDS)*
AD1	NC	-			PL90B	6	LDQ90	C (LVDS)*
AD9	NC	-			PL91A	6	LDQ90	T
-	-	-			VCCIO6	6		
AC11	NC	-			PL91B	6	LDQ90	C
AD6	NC	-			PL92A	6	LDQ90	T (LVDS)*
AD7	NC	-			PL92B	6	LDQ90	C (LVDS)*
AE1	NC	-			PL93A	6	LDQ90	T
-	-	-			GNDIO6	-		
AE2	NC	-			PL93B	6	LDQ90	C
AF2	PL78A	6	LDQ82	T (LVDS)*	PL95A	6	LDQ99	T (LVDS)*
AF1	PL78B	6	LDQ82	C (LVDS)*	PL95B	6	LDQ99	C (LVDS)*
AE5	PL79A	6	LDQ82	T	PL96A	6	LDQ99	T
AE6	PL79B	6	LDQ82	C	PL96B	6	LDQ99	C
AF4	PL80A	6	LDQ82	T (LVDS)*	PL97A	6	LDQ99	T (LVDS)*
VCCIO	VCCIO6	6			VCCIO6	6		
AF3	PL80B	6	LDQ82	C (LVDS)*	PL97B	6	LDQ99	C (LVDS)*
AF5	PL81A	6	LDQ82	T	PL98A	6	LDQ99	T

LFE2M70E/SE and LFE2M100E/SE Logic Signal Connections: 1152 fpBGA

LFE2M70E/SE				LFE2M100E/SE				
Ball Number	Ball/Pad Function	Bank	Dual Function	Differential	Ball/Pad Function	Bank	Dual Function	Differential
AF6	PL81B	6	LDQ82	C	PL98B	6	LDQ99	C
AG1	PL82A	6	LLM0_GPLLT_IN_A**/LDQS82	T (LVDS)*	PL99A	6	LLM0_GPLLT_IN_A**/LDQS99	T (LVDS)*
GNDIO	GNDIO6	-			GNDIO6	-		
AG2	PL82B	6	LLM0_GPLLC_IN_A**/LDQ82	C (LVDS)*	PL99B	6	LLM0_GPLLC_IN_A**/LDQ99	C (LVDS)*
AE9	PL83A	6	LLM0_GPLLT_FB_A/LDQ82	T	PL100A	6	LLM0_GPLLT_FB_A/LDQ99	T
AF7	PL83B	6	LLM0_GPLLC_FB_A/LDQ82	C	PL100B	6	LLM0_GPLLC_FB_A/LDQ99	C
VCCIO	VCCIO6	6			VCCIO6	6		
AH1	PL84A	6	LLM0_GDLLT_IN_A**/LDQ82	T (LVDS)*	PL101A	6	LLM0_GDLLT_IN_A**/LDQ99	T (LVDS)*
AH2	PL84B	6	LLM0_GDLLC_IN_A**/LDQ82	C (LVDS)*	PL101B	6	LLM0_GDLLC_IN_A**/LDQ99	C (LVDS)*
AG5	PL85A	6	LLM0_GDLLT_FB_A/LDQ82	T	PL102A	6	LLM0_GDLLT_FB_A/LDQ99	T
AG4	PL85B	6	LLM0_GDLLC_FB_A/LDQ82	C	PL102B	6	LLM0_GDLLC_FB_A/LDQ99	C
GNDIO	GNDIO6	-			GNDIO6	-		
AG6	LLM0_PLLCAP	6			LLM0_PLLCAP	6		
AJ1	PL87A	6		T	PL104A	6		T
AJ2	PL87B	6		C	PL104B	6		C
AK2	TCK	-			TCK	-		
AK1	TDI	-			TDI	-		
AL1	TMS	-			TMS	-		
AF10	TDO	-			TDO	-		
AK3	VCCJ	-			VCCJ	-		
AN2	LLC_SQ_VCCR3	14			LLC_SQ_VCCR3	14		
AM2	LLC_SQ_HDINP3	14		T	LLC_SQ_HDINP3	14		T
AN1	LLC_SQ_VCCIB3	14			LLC_SQ_VCCIB3	14		
AM3	LLC_SQ_HDINN3	14		C	LLC_SQ_HDINN3	14		C
AN3	LLC_SQ_VCCTX3	14			LLC_SQ_VCCTX3	14		
AP2	LLC_SQ_HDOUTP3	14		T	LLC_SQ_HDOUTP3	14		T
AM1	LLC_SQ_VCCOB3	14			LLC_SQ_VCCOB3	14		
AP3	LLC_SQ_HDOUTN3	14		C	LLC_SQ_HDOUTN3	14		C
AN4	LLC_SQ_VCCTX2	14			LLC_SQ_VCCTX2	14		
AP4	LLC_SQ_HDOUTN2	14		C	LLC_SQ_HDOUTN2	14		C
AL3	LLC_SQ_VCCOB2	14			LLC_SQ_VCCOB2	14		
AP5	LLC_SQ_HDOUTP2	14		T	LLC_SQ_HDOUTP2	14		T
AN5	LLC_SQ_VCCR2	14			LLC_SQ_VCCR2	14		
AM4	LLC_SQ_HDINN2	14		C	LLC_SQ_HDINN2	14		C
AL4	LLC_SQ_VCCIB2	14			LLC_SQ_VCCIB2	14		
AM5	LLC_SQ_HDINP2	14		T	LLC_SQ_HDINP2	14		T
AL6	LLC_SQ_VCCP	14			LLC_SQ_VCCP	14		
AL5	LLC_SQ_REFCLKP	14		T	LLC_SQ_REFCLKP	14		T
AK5	LLC_SQ_REFCLKN	14		C	LLC_SQ_REFCLKN	14		C
AK6	LLC_SQ_VCCAUX33	14			LLC_SQ_VCCAUX33	14		
AM6	LLC_SQ_HDINP1	14		T	LLC_SQ_HDINP1	14		T
AL8	LLC_SQ_VCCIB1	14			LLC_SQ_VCCIB1	14		
AM7	LLC_SQ_HDINN1	14		C	LLC_SQ_HDINN1	14		C
AN6	LLC_SQ_VCCR1	14			LLC_SQ_VCCR1	14		
AP6	LLC_SQ_HDOUTP1	14		T	LLC_SQ_HDOUTP1	14		T
AK7	LLC_SQ_VCCOB1	14			LLC_SQ_VCCOB1	14		
AP7	LLC_SQ_HDOUTN1	14		C	LLC_SQ_HDOUTN1	14		C
AN7	LLC_SQ_VCCTX1	14			LLC_SQ_VCCTX1	14		
AP8	LLC_SQ_HDOUTN0	14		C	LLC_SQ_HDOUTN0	14		C

LFE2M70E/SE and LFE2M100E/SE Logic Signal Connections: 1152 fpBGA

LFE2M70E/SE				LFE2M100E/SE				
Ball Number	Ball/Pad Function	Bank	Dual Function	Differential	Ball/Pad Function	Bank	Dual Function	Differential
AL9	LLC_SQ_VCCOB0	14			LLC_SQ_VCCOB0	14		
AP9	LLC_SQ_HDOUPT0	14		T	LLC_SQ_HDOUPT0	14		T
AN8	LLC_SQ_VCCTX0	14			LLC_SQ_VCCTX0	14		
AM8	LLC_SQ_HDINN0	14		C	LLC_SQ_HDINN0	14		C
AN9	LLC_SQ_VCCIB0	14			LLC_SQ_VCCIB0	14		
AM9	LLC_SQ_HDINP0	14		T	LLC_SQ_HDINP0	14		T
AL7	LLC_SQ_VCCRX0	14			LLC_SQ_VCCRX0	14		
-	-	-			VCCIO5	5		
AJ12	NC	-			PB32A	5	BDQ33	T
AH12	NC	-			PB32B	5	BDQ33	C
-	-	-			GNDIO5	-		
-	-	-			VCCIO5	5		
AL13	NC	-			PB36A	5	BDQ33	T
AK13	NC	-			PB36B	5	BDQ33	C
-	-	-			GNDIO5	-		
AE14	NC	-			PB38A	5	BDQ42	T
AG13	NC	-			PB38B	5	BDQ42	C
AN14	PB30A	5	BDQ33	T	PB39A	5	BDQ42	T
AP14	PB30B	5	BDQ33	C	PB39B	5	BDQ42	C
AH14	PB31A	5	BDQ33	T	PB40A	5	BDQ42	T
AJ15	PB31B	5	BDQ33	C	PB40B	5	BDQ42	C
VCCIO	VCCIO5	5			VCCIO5	5		
GNDIO	GNDIO5	-			GNDIO5	-		
AL14	PB33A	5	BDQS33	T	PB42A	5	BDQS42	T
AM14	PB33B	5	BDQ33	C	PB42B	5	BDQ42	C
AF14	PB35A	5	BDQ33	T	PB44A	5	BDQ42	T
AF13	PB35B	5	BDQ33	C	PB44B	5	BDQ42	C
VCCIO	VCCIO5	5			VCCIO5	5		
AE15	PB36A	5	BDQ33	T	PB45A	5	BDQ42	T
AG14	PB36B	5	BDQ33	C	PB45B	5	BDQ42	C
AH15	PB37A	5	BDQ33	T	PB46A	5	BDQ42	T
AK15	PB37B	5	BDQ33	C	PB46B	5	BDQ42	C
GNDIO	GNDIO5	-			GNDIO5	-		
AL15	PB38A	5	BDQ42	T	PB47A	5	BDQ51	T
AM15	PB38B	5	BDQ42	C	PB47B	5	BDQ51	C
AK16	PB39A	5	BDQ42	T	PB48A	5	BDQ51	T
AJ16	PB39B	5	BDQ42	C	PB48B	5	BDQ51	C
AN15	PB40A	5	BDQ42	T	PB49A	5	BDQ51	T
VCCIO	VCCIO5	5			VCCIO5	5		
AP15	PB40B	5	BDQ42	C	PB49B	5	BDQ51	C
AG15	PB42A	5	BDQS42	T	PB51A	5	BDQS51	T
GNDIO	GNDIO5	-			GNDIO5	-		
AE16	PB42B	5	BDQ42	C	PB51B	5	BDQ51	C
AF15	PB44A	5	BDQ42	T	PB53A	5	BDQ51	T
VCCIO	VCCIO5	5			VCCIO5	5		
AD16	PB44B	5	BDQ42	C	PB53B	5	BDQ51	C
AK17	PB45A	5	BDQ42	T	PB54A	5	BDQ51	T
AH16	PB45B	5	BDQ42	C	PB54B	5	BDQ51	C
AN16	PB46A	5	BDQ42	T	PB55A	5	BDQ51	T
GNDIO	GNDIO5	-			GNDIO5	-		
AP16	PB46B	5	BDQ42	C	PB55B	5	BDQ51	C

LFE2M70E/SE and LFE2M100E/SE Logic Signal Connections: 1152 fpBGA

LFE2M70E/SE				LFE2M100E/SE				
Ball Number	Ball/Pad Function	Bank	Dual Function	Differential	Ball/Pad Function	Bank	Dual Function	Differential
AL17	PB47A	5	BDQ51	T	PB56A	5	BDQ60	T
AM17	PB47B	5	BDQ51	C	PB56B	5	BDQ60	C
AN17	PB48A	5	BDQ51	T	PB57A	5	BDQ60	T
AP17	PB48B	5	BDQ51	C	PB57B	5	BDQ60	C
AD17	PB49A	5	BDQ51	T	PB58A	5	BDQ60	T
AE17	PB49B	5	BDQ51	C	PB58B	5	BDQ60	C
VCCIO	VCCIO5	5			VCCIO5	5		
AL18	PB50A	5	BDQ51	T	PB59A	5	BDQ60	T
AM18	PB50B	5	BDQ51	C	PB59B	5	BDQ60	C
GNDIO	GNDIO5	-			GNDIO5	-		
AP18	PB51A	5	BDQS51	T	PB60A	5	BDQS60	T
AN18	PB51B	5	BDQ51	C	PB60B	5	BDQ60	C
AG17	PB52A	5	VREF2_5/BDQ51	T	PB61A	5	VREF2_5/BDQ60	T
AJ17	PB52B	5	VREF1_5/BDQ51	C	PB61B	5	VREF1_5/BDQ60	C
AF17	PB53A	5	PCLKT5_0/BDQ51	T	PB62A	5	PCLKT5_0/BDQ60	T
AH17	PB53B	5	PCLKC5_0/BDQ51	C	PB62B	5	PCLKC5_0/BDQ60	C
VCCIO	VCCIO5	5			VCCIO5	5		
GNDIO	GNDIO5	-			GNDIO5	-		
AF18	PB58A	4	PCLKT4_0/BDQ60	T	PB67A	4	PCLKT4_0/BDQ69	T
VCCIO	VCCIO4	4			VCCIO4	4		
AD18	PB58B	4	PCLKC4_0/BDQ60	C	PB67B	4	PCLKC4_0/BDQ69	C
AP19	PB59A	4	VREF2_4/BDQ60	T	PB68A	4	VREF2_4/BDQ69	T
AN19	PB59B	4	VREF1_4/BDQ60	C	PB68B	4	VREF1_4/BDQ69	C
AP20	PB60A	4	BDQS60	T	PB69A	4	BDQS69	T
GNDIO	GNDIO4	-			GNDIO4	-		
AM20	PB60B	4	BDQ60	C	PB69B	4	BDQ69	C
AN20	PB61A	4	BDQ60	T	PB70A	4	BDQ69	T
AM21	PB61B	4	BDQ60	C	PB70B	4	BDQ69	C
AG18	PB62A	4	BDQ60	T	PB71A	4	BDQ69	T
VCCIO	VCCIO4	4			VCCIO4	4		
AE18	PB62B	4	BDQ60	C	PB71B	4	BDQ69	C
AJ18	PB63A	4	BDQ60	T	PB72A	4	BDQ69	T
AH18	PB63B	4	BDQ60	C	PB72B	4	BDQ69	C
AK18	PB64A	4	BDQ60	T	PB73A	4	BDQ69	T
GNDIO	GNDIO4	-			GNDIO4	-		
AK19	PB64B	4	BDQ60	C	PB73B	4	BDQ69	C
AP21	PB65A	4	BDQ69	T	PB74A	4	BDQ78	T
AN21	PB65B	4	BDQ69	C	PB74B	4	BDQ78	C
AL20	PB66A	4	BDQ69	T	PB75A	4	BDQ78	T
AK20	PB66B	4	BDQ69	C	PB75B	4	BDQ78	C
AN22	PB67A	4	BDQ69	T	PB76A	4	BDQ78	T
AL21	PB67B	4	BDQ69	C	PB76B	4	BDQ78	C
VCCIO	VCCIO4	4			VCCIO4	4		
GNDIO	GNDIO4	-			GNDIO4	-		
AH19	PB69A	4	BDQS69	T	PB78A	4	BDQS78	T
AJ20	PB69B	4	BDQ69	C	PB78B	4	BDQ78	C
AD20	PB71A	4	BDQ69	T	PB80A	4	BDQ78	T
AF20	PB71B	4	BDQ69	C	PB80B	4	BDQ78	C
VCCIO	VCCIO4	4			VCCIO4	4		
AJ19	PB72A	4	BDQ69	T	PB81A	4	BDQ78	T
AH20	PB72B	4	BDQ69	C	PB81B	4	BDQ78	C

LFE2M70E/SE and LFE2M100E/SE Logic Signal Connections: 1152 fpBGA

LFE2M70E/SE				LFE2M100E/SE				
Ball Number	Ball/Pad Function	Bank	Dual Function	Differential	Ball/Pad Function	Bank	Dual Function	Differential
AE20	PB73A	4	BDQ69	T	PB82A	4	BDQ78	T
AG20	PB73B	4	BDQ69	C	PB82B	4	BDQ78	C
GNDIO	GNDIO4	-			GNDIO4	-		
AH22	NC	-			PB89A	4	BDQ87	T
-	-	-			VCCIO4	4		
AH21	NC	-			PB89B	4	BDQ87	C
AG22	NC	-			PB90A	4	BDQ87	T
AG21	NC	-			PB90B	4	BDQ87	C
-	-	-			GNDIO4	-		
AM22	PB74A	4	BDQ78	T	PB92A	4	BDQ96	T
AL22	PB74B	4	BDQ78	C	PB92B	4	BDQ96	C
VCCIO	VCCIO4	4			VCCIO4	4		
AP23	PB77A	4	BDQ78	T	PB95A	4	BDQ96	T
AN23	PB77B	4	BDQ78	C	PB95B	4	BDQ96	C
GNDIO	GNDIO4	-			GNDIO4	-		
AM24	PB78A	4	BDQS78	T	PB96A	4	BDQS96	T
AL24	PB78B	4	BDQ78	C	PB96B	4	BDQ96	C
AK22	PB79A	4	BDQ78	T	PB97A	4	BDQ96	T
AJ22	PB79B	4	BDQ78	C	PB97B	4	BDQ96	C
AL23	PB80A	4	BDQ78	T	PB98A	4	BDQ96	T
AK23	PB80B	4	BDQ78	C	PB98B	4	BDQ96	C
VCCIO	VCCIO4	4			VCCIO4	4		
AJ23	PB81A	4	BDQ78	T	PB99A	4	BDQ96	T
AH23	PB81B	4	BDQ78	C	PB99B	4	BDQ96	C
GNDIO	GNDIO4	-			GNDIO4	-		
AL28	LRC_SQ_VCCRX3	13			LRC_SQ_VCCRX3	13		
AM26	LRC_SQ_HDINP3	13		T	LRC_SQ_HDINP3	13		T
AN26	LRC_SQ_VCCIB3	13			LRC_SQ_VCCIB3	13		
AM27	LRC_SQ_HDINN3	13		C	LRC_SQ_HDINN3	13		C
AN27	LRC_SQ_VCCTX3	13			LRC_SQ_VCCTX3	13		
AP26	LRC_SQ_HDOUTP3	13		T	LRC_SQ_HDOUTP3	13		T
AL26	LRC_SQ_VCCOB3	13			LRC_SQ_VCCOB3	13		
AP27	LRC_SQ_HDOUTN3	13		C	LRC_SQ_HDOUTN3	13		C
AN28	LRC_SQ_VCCTX2	13			LRC_SQ_VCCTX2	13		
AP28	LRC_SQ_HDOUTN2	13		C	LRC_SQ_HDOUTN2	13		C
AK28	LRC_SQ_VCCOB2	13			LRC_SQ_VCCOB2	13		
AP29	LRC_SQ_HDOUTP2	13		T	LRC_SQ_HDOUTP2	13		T
AN29	LRC_SQ_VCCRX2	13			LRC_SQ_VCCRX2	13		
AM28	LRC_SQ_HDINN2	13		C	LRC_SQ_HDINN2	13		C
AL27	LRC_SQ_VCCIB2	13			LRC_SQ_VCCIB2	13		
AM29	LRC_SQ_HDINP2	13		T	LRC_SQ_HDINP2	13		T
AL29	LRC_SQ_VCCP	13			LRC_SQ_VCCP	13		
AL30	LRC_SQ_REFCLKP	13		T	LRC_SQ_REFCLKP	13		T
AK30	LRC_SQ_REFCLKN	13		C	LRC_SQ_REFCLKN	13		C
AK29	LRC_SQ_VCCAUX33	13			LRC_SQ_VCCAUX33	13		
AM30	LRC_SQ_HDINP1	13		T	LRC_SQ_HDINP1	13		T
AL31	LRC_SQ_VCCIB1	13			LRC_SQ_VCCIB1	13		
AM31	LRC_SQ_HDINN1	13		C	LRC_SQ_HDINN1	13		C
AN30	LRC_SQ_VCCRX1	13			LRC_SQ_VCCRX1	13		
AP30	LRC_SQ_HDOUTP1	13		T	LRC_SQ_HDOUTP1	13		T
AL32	LRC_SQ_VCCOB1	13			LRC_SQ_VCCOB1	13		

LFE2M70E/SE and LFE2M100E/SE Logic Signal Connections: 1152 fpBGA

LFE2M70E/SE				LFE2M100E/SE				
Ball Number	Ball/Pad Function	Bank	Dual Function	Differential	Ball/Pad Function	Bank	Dual Function	Differential
AP31	LRC_SQ_HDOUTN1	13		C	LRC_SQ_HDOUTN1	13		C
AN31	LRC_SQ_VCCTX1	13			LRC_SQ_VCCTX1	13		
AP32	LRC_SQ_HDOUTN0	13		C	LRC_SQ_HDOUTN0	13		C
AM34	LRC_SQ_VCCOB0	13			LRC_SQ_VCCOB0	13		
AP33	LRC_SQ_HDOUTP0	13		T	LRC_SQ_HDOUTP0	13		T
AN32	LRC_SQ_VCCTX0	13			LRC_SQ_VCCTX0	13		
AM32	LRC_SQ_HDINN0	13		C	LRC_SQ_HDINN0	13		C
AN34	LRC_SQ_VCCIB0	13			LRC_SQ_VCCIB0	13		
AM33	LRC_SQ_HDINP0	13		T	LRC_SQ_HDINP0	13		T
AN33	LRC_SQ_VCCRX0	13			LRC_SQ_VCCRX0	13		
AH28	CFG2	8			CFG2	8		
AD24	CFG1	8			CFG1	8		
AJ29	CFG0	8			CFG0	8		
AF25	PROGRAMN	8			PROGRAMN	8		
AJ28	CCLK	8			CCLK	8		
AE25	INITN	8			INITN	8		
AK31	DONE	8			DONE	8		
GNDIO	GNDIO8	-			GNDIO8	-		
AE24	WRITEN***	8			WRITEN***	8		
AJ30	CS1N***	8			CS1N***	8		
AD25	CSN***	8			CSN***	8		
AG29	D0/SPIFASTN***	8			D0/SPIFASTN***	8		
VCCIO	VCCIO8	8			VCCIO8	8		
AG28	D1***	8			D1***	8		
AG30	D2***	8			D2***	8		
AH29	D3***	8			D3***	8		
GNDIO	GNDIO8	-			GNDIO8	-		
AF26	D4***	8			D4***	8		
AH30	D5***	8			D5***	8		
AE26	D6***	8			D6***	8		
AJ31	D7***	8			D7***	8		
VCCIO	VCCIO8	8			VCCIO8	8		
AG27	DI/CSSPI0N***	8			DI/CSSPI0N***	8		
AK32	DOUT/CSON/ CSSPI1N***	8			DOUT/CSON/ CSSPI1N***	8		
AK33	BUSY/SISPI***	8			BUSY/SISPI***	8		
AF27	RLM0_PLLCAP	3			RLM0_PLLCAP	3		
AF28	PR85B	3	RLM0_GDLLC_FB_A	C	PR102B	3	RLM0_GDLLC_FB_A/RDQ99	C
GNDIO	GNDIO3	-			GNDIO3	-		
AD26	PR85A	3	RLM0_GDLLT_FB_A	T	PR102A	3	RLM0_GDLLT_FB_A/RDQ99	T
AJ32	PR84B	3	RLM0_GDLLC_IN_A**	C (LVDS)*	PR101B	3	RLM0_GDLLC_IN_A**/ RDQ99	C (LVDS)*
AJ33	PR84A	3	RLM0_GDLLT_IN_A**	T (LVDS)*	PR101A	3	RLM0_GDLLT_IN_A**/ RDQ99	T (LVDS)*
AJ34	PR83B	3	RLM0_GPLLC_IN_A**	C	PR100B	3	RLM0_GPLLC_IN_A**/ RDQ99	C
VCCIO	VCCIO3	3			VCCIO3	3		
AK34	PR83A	3	RLM0_GPLLT_IN_A**	T	PR100A	3	RLM0_GPLLT_IN_A**/ RDQ99	T
AH33	PR82B	3	RLM0_GPLLC_FB_A	C (LVDS)*	PR99B	3	RLM0_GPLLC_FB_A/RDQ99	C (LVDS)*
AH34	PR82A	3	RLM0_GPLLT_FB_A/RDQS82****	T (LVDS)*	PR99A	3	RLM0_GPLLT_FB_A/ RDQS99	T (LVDS)*
GNDIO	GNDIO3	-			GNDIO3	-		

LFE2M70E/SE and LFE2M100E/SE Logic Signal Connections: 1152 fpBGA

LFE2M70E/SE				LFE2M100E/SE				
Ball Number	Ball/Pad Function	Bank	Dual Function	Differential	Ball/Pad Function	Bank	Dual Function	Differential
AF29	PR81B	3	RDQ82	C	PR98B	3	RDQ99	C
AF31	PR81A	3	RDQ82	T	PR98A	3	RDQ99	T
AG33	PR80B	3	RDQ82	C (LVDS)*	PR97B	3	RDQ99	C (LVDS)*
AG34	PR80A	3	RDQ82	T (LVDS)*	PR97A	3	RDQ99	T (LVDS)*
VCCIO	VCCIO3	3			VCCIO3	3		
AF30	PR79B	3	RDQ82	C	PR96B	3	RDQ99	C
AF32	PR79A	3	RDQ82	T	PR96A	3	RDQ99	T
AE29	PR78B	3	RDQ82	C (LVDS)*	PR95B	3	RDQ99	C (LVDS)*
AE30	PR78A	3	RDQ82	T (LVDS)*	PR95A	3	RDQ99	T (LVDS)*
AF33	NC	-			PR93B	3	RDQ90	C
AF34	NC	-			PR93A	3	RDQ90	T
-	-	-			GNDIO3	-		
AC27	NC	-			PR92B	3	RDQ90	C (LVDS)*
AC28	NC	-			PR92A	3	RDQ90	T (LVDS)*
AD29	NC	-			PR91B	3	RDQ90	C
AD30	NC	-			PR91A	3	RDQ90	T
-	-	-			VCCIO3	3		
AE33	NC	-			PR90B	3	RDQ90	C (LVDS)*
AE34	NC	-			PR90A	3	RDQS90	T (LVDS)*
AD32	NC	-			PR89B	3	RDQ90	C
-	-	-			GNDIO3	-		
AD31	NC	-			PR89A	3	RDQ90	T
AB25	NC	-			PR88B	3	RDQ90	C (LVDS)*
AC25	NC	-			PR88A	3	RDQ90	T (LVDS)*
AB28	NC	-			PR87B	3	RDQ90	C
-	-	-			VCCIO3	3		
AA26	NC	-			PR87A	3	RDQ90	T
AD33	NC	-			PR86B	3	RDQ90	C (LVDS)*
AD34	NC	-			PR86A	3	RDQ90	T (LVDS)*
AC29	PR76B	3	RDQ73	C	PR84B	3	RDQ81	C
GNDIO	GNDIO3	-			GNDIO3	-		
AA27	PR76A	3	RDQ73	T	PR84A	3	RDQ81	T
AC32	PR75B	3	RDQ73	C (LVDS)*	PR83B	3	RDQ81	C (LVDS)*
AC31	PR75A	3	RDQ73	T (LVDS)*	PR83A	3	RDQ81	T (LVDS)*
AA25	PR74B	3	RDQ73	C	PR82B	3	RDQ81	C
VCCIO	VCCIO3	3			VCCIO3	3		
AC24	PR74A	3	RDQ73	T	PR82A	3	RDQ81	T
AC33	PR73B	3	RDQ73	C (LVDS)*	PR81B	3	RDQ81	C (LVDS)*
AC34	PR73A	3	RDQS73	T (LVDS)*	PR81A	3	RDQS81	T (LVDS)*
GNDIO	GNDIO3	-			GNDIO3	-		
AB24	PR72B	3	RDQ73	C	PR80B	3	RDQ81	C
Y26	PR72A	3	RDQ73	T	PR80A	3	RDQ81	T
AB33	PR71B	3	RDQ73	C (LVDS)*	PR79B	3	RDQ81	C (LVDS)*
AB34	PR71A	3	RDQ73	T (LVDS)*	PR79A	3	RDQ81	T (LVDS)*
VCCIO	VCCIO3	3			VCCIO3	3		
Y27	PR70B	3	RDQ73	C	PR78B	3	RDQ81	C
AB29	PR70A	3	RDQ73	T	PR78A	3	RDQ81	T
AA34	PR69B	3	RDQ73	C (LVDS)*	PR77B	3	RDQ81	C (LVDS)*
AA33	PR69A	3	RDQ73	T (LVDS)*	PR77A	3	RDQ81	T (LVDS)*
AA31	PR67B	3	RDQ64	C	PR75B	3	RDQ72	C
AA32	PR67A	3	RDQ64	T	PR75A	3	RDQ72	T

LFE2M70E/SE and LFE2M100E/SE Logic Signal Connections: 1152 fpBGA

LFE2M70E/SE				LFE2M100E/SE				
Ball Number	Ball/Pad Function	Bank	Dual Function	Differential	Ball/Pad Function	Bank	Dual Function	Differential
GNDIO	GNDIO3	-			GNDIO3	-		
AA28	PR66B	3	RDQ64	C (LVDS)*	PR74B	3	RDQ72	C (LVDS)*
AA29	PR66A	3	RDQ64	T (LVDS)*	PR74A	3	RDQ72	T (LVDS)*
AA30	PR65B	3	RDQ64	C	PR73B	3	RDQ72	C
AB30	PR65A	3	RDQ64	T	PR73A	3	RDQ72	T
VCCIO	VCCIO3	3			VCCIO3	3		
Y28	PR64B	3	RDQ64	C (LVDS)*	PR72B	3	RDQ72	C (LVDS)*
Y29	PR64A	3	RDQS64	T (LVDS)*	PR72A	3	RDQS72	T (LVDS)*
AA24	PR63B	3	RDQ64	C	PR71B	3	RDQ72	C
GNDIO	GNDIO3	-			GNDIO3	-		
Y25	PR63A	3	RDQ64	T	PR71A	3	RDQ72	T
Y31	PR62B	3	RDQ64	C (LVDS)*	PR70B	3	RDQ72	C (LVDS)*
Y30	PR62A	3	RDQ64	T (LVDS)*	PR70A	3	RDQ72	T (LVDS)*
Y24	PR61B	3	RDQ64	C	PR69B	3	RDQ72	C
VCCIO	VCCIO3	3			VCCIO3	3		
W25	PR61A	3	RDQ64	T	PR69A	3	RDQ72	T
Y33	PR60B	3	RDQ64	C (LVDS)*	PR68B	3	RDQ72	C (LVDS)*
Y34	PR60A	3	RDQ64	T (LVDS)*	PR68A	3	RDQ72	T (LVDS)*
W28	PR58B	3	RLM3_SPLLC_FB_A/RDQ55	C	PR66B	3	RLM4_SPLLC_FB_A/RDQ63	C
GNDIO	GNDIO3	-			GNDIO3	-		
V26	PR58A	3	RLM3_SPLLT_FB_A/RDQ55	T	PR66A	3	RLM4_SPLLT_FB_A/RDQ63	T
V28	PR57B	3	RLM3_SPLLC_IN_A/RDQ55	C (LVDS)*	PR65B	3	RLM4_SPLLC_IN_A/RDQ63	C (LVDS)*
V27	PR57A	3	RLM3_SPLLT_IN_A/RDQ55	T (LVDS)*	PR65A	3	RLM4_SPLLT_IN_A/RDQ63	T (LVDS)*
V25	PR56B	3	RDQ55	C	PR64B	3	RDQ63	C
VCCIO	VCCIO3	3			VCCIO3	3		
W24	PR56A	3	RDQ55	T	PR64A	3	RDQ63	T
W33	PR55B	3	RDQ55	C (LVDS)*	PR63B	3	RDQ63	C (LVDS)*
W34	PR55A	3	RDQS55	T (LVDS)*	PR63A	3	RDQS63	T (LVDS)*
GNDIO	GNDIO3	-			GNDIO3	-		
V24	PR54B	3	RDQ55	C	PR62B	3	RDQ63	C
U26	PR54A	3	RDQ55	T	PR62A	3	RDQ63	T
W29	PR53B	3	RDQ55	C (LVDS)*	PR61B	3	RDQ63	C (LVDS)*
W30	PR53A	3	RDQ55	T (LVDS)*	PR61A	3	RDQ63	T (LVDS)*
VCCIO	VCCIO3	3			VCCIO3	3		
U27	PR52B	3	VREF2_3/RDQ55	C	PR60B	3	VREF2_3/RDQ63	C
V29	PR52A	3	VREF1_3/RDQ55	T	PR60A	3	VREF1_3/RDQ63	T
V31	PR51B	3	PCLKC3_0/RDQ55	C (LVDS)*	PR59B	3	PCLKC3_0/RDQ63	C (LVDS)*
V32	PR51A	3	PCLKT3_0/RDQ55	T (LVDS)*	PR59A	3	PCLKT3_0/RDQ63	T (LVDS)*
V33	PR49B	2	PCLKC2_0/RDQ46	C	PR57B	2	PCLKC2_0/RDQ54	C
V34	PR49A	2	PCLKT2_0/RDQ46	T	PR57A	2	PCLKT2_0/RDQ54	T
GNDIO	GNDIO2	-			GNDIO2	-		
U24	PR48B	2	RDQ46	C (LVDS)*	PR56B	2	RDQ54	C (LVDS)*
U25	PR48A	2	RDQ46	T (LVDS)*	PR56A	2	RDQ54	T (LVDS)*
V30	PR47B	2	RDQ46	C	PR55B	2	RDQ54	C
Y32	PR47A	2	RDQ46	T	PR55A	2	RDQ54	T
VCCIO	VCCIO2	2			VCCIO2	2		
U28	PR46B	2	RDQ46	C (LVDS)*	PR54B	2	RDQ54	C (LVDS)*
U29	PR46A	2	RDQS46	T (LVDS)*	PR54A	2	RDQS54	T (LVDS)*
U33	PR45B	2	RDQ46	C	PR53B	2	RDQ54	C
GNDIO	GNDIO2	-			GNDIO2	-		
U34	PR45A	2	RDQ46	T	PR53A	2	RDQ54	T

LFE2M70E/SE and LFE2M100E/SE Logic Signal Connections: 1152 fpBGA

LFE2M70E/SE				LFE2M100E/SE				
Ball Number	Ball/Pad Function	Bank	Dual Function	Differential	Ball/Pad Function	Bank	Dual Function	Differential
T30	PR44B	2	RDQ46	C (LVDS)*	PR52B	2	RDQ54	C (LVDS)*
U30	PR44A	2	RDQ46	T (LVDS)*	PR52A	2	RDQ54	T (LVDS)*
T29	PR43B	2	RUM3_SPLLC_FB_A/RDQ46	C	PR51B	2	RUM3_SPLLC_FB_A/RDQ54	C
VCCIO	VCCIO2	2			VCCIO2	2		
T28	PR43A	2	RUM3_SPLLT_FB_A/RDQ46	T	PR51A	2	RUM3_SPLLT_FB_A/RDQ54	T
U31	PR42B	2	RUM3_SPLLC_IN_A/RDQ46	C (LVDS)*	PR50B	2	RUM3_SPLLC_IN_A/RDQ54	C (LVDS)*
U32	PR42A	2	RUM3_SPLLT_IN_A/RDQ46	T (LVDS)*	PR50A	2	RUM3_SPLLT_IN_A/RDQ54	T (LVDS)*
T33	PR40B	2	RDQ37	C	PR48B	2	RDQ45	C
T34	PR40A	2	RDQ37	T	PR48A	2	RDQ45	T
GNDIO	GNDIO2	-			GNDIO2	-		
R27	PR39B	2	RDQ37	C (LVDS)*	PR47B	2	RDQ45	C (LVDS)*
R28	PR39A	2	RDQ37	T (LVDS)*	PR47A	2	RDQ45	T (LVDS)*
R29	PR38B	2	RDQ37	C	PR46B	2	RDQ45	C
R30	PR38A	2	RDQ37	T	PR46A	2	RDQ45	T
VCCIO	VCCIO2	2			VCCIO2	2		
R33	PR37B	2	RDQ37	C (LVDS)*	PR45B	2	RDQ45	C (LVDS)*
R34	PR37A	2	RDQS37	T (LVDS)*	PR45A	2	RDQS45	T (LVDS)*
R32	PR36B	2	RDQ37	C	PR44B	2	RDQ45	C
GNDIO	GNDIO2	-			GNDIO2	-		
R31	PR36A	2	RDQ37	T	PR44A	2	RDQ45	T
P34	PR35B	2	RDQ37	C (LVDS)*	PR43B	2	RDQ45	C (LVDS)*
P33	PR35A	2	RDQ37	T (LVDS)*	PR43A	2	RDQ45	T (LVDS)*
R26	PR34B	2	RDQ37	C	PR42B	2	RDQ45	C
VCCIO	VCCIO2	2			VCCIO2	2		
T25	PR34A	2	RDQ37	T	PR42A	2	RDQ45	T
P28	PR33B	2	RDQ37	C (LVDS)*	PR41B	2	RDQ45	C (LVDS)*
P27	PR33A	2	RDQ37	T (LVDS)*	PR41A	2	RDQ45	T (LVDS)*
P30	NC	-			PR40B	2		C
-	-	-			GNDIO2	-		
P29	NC	-			PR40A	2		T
P31	NC	-			PR39B	2		C (LVDS)*
P32	NC	-			PR39A	2		T (LVDS)*
R25	NC	-			PR38B	2		C
-	-	-			VCCIO2	2		
T24	NC	-			PR38A	2		T
N34	NC	-			PR37B	2		C (LVDS)*
N33	NC	-			PR37A	2		T (LVDS)*
GNDIO	GNDIO2	-			GNDIO2	-		
M34	PR31B	2	RDQ28	C	PR35B	2	RDQ32	C
M33	PR31A	2	RDQ28	T	PR35A	2	RDQ32	T
-	-	-			GNDIO2	-		
R24	PR30B	2	RDQ28	C (LVDS)*	PR34B	2	RDQ32	C (LVDS)*
P24	PR30A	2	RDQ28	T (LVDS)*	PR34A	2	RDQ32	T (LVDS)*
N30	PR29B	2	RDQ28	C	PR33B	2	RDQ32	C
M29	PR29A	2	RDQ28	T	PR33A	2	RDQ32	T
VCCIO	VCCIO2	2			VCCIO2	2		
N28	PR28B	2	RDQ28	C (LVDS)*	PR32B	2	RDQ32	C (LVDS)*
N29	PR28A	2	RDQS28	T (LVDS)*	PR32A	2	RDQS32	T (LVDS)*
N24	PR27B	2	RDQ28	C	PR31B	2	RDQ32	C
GNDIO	GNDIO2	-			GNDIO2	-		
N25	PR27A	2	RDQ28	T	PR31A	2	RDQ32	T

LFE2M70E/SE and LFE2M100E/SE Logic Signal Connections: 1152 fpBGA

LFE2M70E/SE				LFE2M100E/SE				
Ball Number	Ball/Pad Function	Bank	Dual Function	Differential	Ball/Pad Function	Bank	Dual Function	Differential
M28	PR26B	2	RDQ28	C (LVDS)*	PR30B	2	RDQ32	C (LVDS)*
M27	PR26A	2	RDQ28	T (LVDS)*	PR30A	2	RDQ32	T (LVDS)*
L27	PR25B	2	RDQ28	C	PR29B	2	RDQ32	C
VCCIO	VCCIO2	2			VCCIO2	2		
M26	PR25A	2	RDQ28	T	PR29A	2	RDQ32	T
M32	PR24B	2	RDQ28	C (LVDS)*	PR28B	2	RDQ32	C (LVDS)*
M31	PR24A	2	RDQ28	T (LVDS)*	PR28A	2	RDQ32	T (LVDS)*
GNDIO	GNDIO2	-			GNDIO2	-		
-	-	-			VCCIO2	2		
L34	PR22B	2		C	PR22B	2	RDQ23	C
L33	PR22A	2		T	PR22A	2	RDQ23	T
L32	PR21B	2		C (LVDS)*	PR21B	2	RDQ23	C (LVDS)*
L31	PR21A	2		T (LVDS)*	PR21A	2	RDQ23	T (LVDS)*
VCCIO	VCCIO2	2			VCCIO2	2		
L28	PR20B	2		C	PR20B	2	RDQ23	C
L29	PR20A	2		T	PR20A	2	RDQ23	T
M30	PR19B	2		C (LVDS)*	PR19B	2	RDQ23	C (LVDS)*
L30	PR19A	2		T (LVDS)*	PR19A	2	RDQ23	T (LVDS)*
K34	PR18B	2	RDQ15	C	PR18B	2	RDQ15	C
K33	PR18A	2	RDQ15	T	PR18A	2	RDQ15	T
GNDIO	GNDIO2	-			GNDIO2	-		
K30	PR17B	2	RDQ15	C (LVDS)*	PR17B	2	RDQ15	C (LVDS)*
K29	PR17A	2	RDQ15	T (LVDS)*	PR17A	2	RDQ15	T (LVDS)*
J34	PR16B	2	RDQ15	C	PR16B	2	RDQ15	C
J33	PR16A	2	RDQ15	T	PR16A	2	RDQ15	T
VCCIO	VCCIO2	2			VCCIO2	2		
J32	PR15B	2	RDQ15	C (LVDS)*	PR15B	2	RDQ15	C (LVDS)*
J31	PR15A	2	RDQS15	T (LVDS)*	PR15A	2	RDQS15	T (LVDS)*
H33	PR14B	2	RDQ15	C	PR14B	2	RDQ15	C
GNDIO	GNDIO2	-			GNDIO2	-		
H34	PR14A	2	RDQ15	T	PR14A	2	RDQ15	T
J30	PR13B	2	RDQ15	C (LVDS)*	PR13B	2	RDQ15	C (LVDS)*
J29	PR13A	2	RDQ15	T (LVDS)*	PR13A	2	RDQ15	T (LVDS)*
VCCIO	VCCIO2	2			VCCIO2	2		
J27	PR11B	2	RUM0_SPLLC_IN_A/RDQ15	C (LVDS)*	PR11B	2	RUM0_SPLLC_IN_A/RDQ15	C (LVDS)*
J28	PR11A	2	RUM0_SPLLT_IN_A/RDQ15	T (LVDS)*	PR11A	2	RUM0_SPLLT_IN_A/RDQ15	T (LVDS)*
H31	PR9B	2	VREF2_2	C	PR9B	2	VREF2_2	C
GNDIO	GNDIO2	-			GNDIO2	-		
H32	PR9A	2	VREF1_2	T	PR9A	2	VREF1_2	T
VCCIO	VCCIO2	2			VCCIO2	2		
H30	XRES	1			XRES	1		
B33	URC_SQ_VCCRX0	12			URC_SQ_VCCRX0	12		
C33	URC_SQ_HDINP0	12		T	URC_SQ_HDINP0	12		T
B34	URC_SQ_VCCIB0	12			URC_SQ_VCCIB0	12		
C32	URC_SQ_HDINN0	12		C	URC_SQ_HDINN0	12		C
B32	URC_SQ_VCCTX0	12			URC_SQ_VCCTX0	12		
A33	URC_SQ_HDOUTP0	12		T	URC_SQ_HDOUTP0	12		T
C34	URC_SQ_VCCOB0	12			URC_SQ_VCCOB0	12		
A32	URC_SQ_HDOUTN0	12		C	URC_SQ_HDOUTN0	12		C
B31	URC_SQ_VCCTX1	12			URC_SQ_VCCTX1	12		
A31	URC_SQ_HDOUTN1	12		C	URC_SQ_HDOUTN1	12		C

LFE2M70E/SE and LFE2M100E/SE Logic Signal Connections: 1152 fpBGA

LFE2M70E/SE				LFE2M100E/SE				
Ball Number	Ball/Pad Function	Bank	Dual Function	Differential	Ball/Pad Function	Bank	Dual Function	Differential
D32	URC_SQ_VCCOB1	12			URC_SQ_VCCOB1	12		
A30	URC_SQ_HDOUTP1	12		T	URC_SQ_HDOUTP1	12		T
B30	URC_SQ_VCCRX1	12			URC_SQ_VCCRX1	12		
C31	URC_SQ_HDINN1	12		C	URC_SQ_HDINN1	12		C
D31	URC_SQ_VCCIB1	12			URC_SQ_VCCIB1	12		
C30	URC_SQ_HDINP1	12		T	URC_SQ_HDINP1	12		T
E29	URC_SQ_VCCAUX33	12			URC_SQ_VCCAUX33	12		
E30	URC_SQ_REFCLKN	12		C	URC_SQ_REFCLKN	12		C
D30	URC_SQ_REFCLKP	12		T	URC_SQ_REFCLKP	12		T
D29	URC_SQ_VCCP	12			URC_SQ_VCCP	12		
C29	URC_SQ_HDINP2	12		T	URC_SQ_HDINP2	12		T
D27	URC_SQ_VCCIB2	12			URC_SQ_VCCIB2	12		
C28	URC_SQ_HDINN2	12		C	URC_SQ_HDINN2	12		C
B29	URC_SQ_VCCRX2	12			URC_SQ_VCCRX2	12		
A29	URC_SQ_HDOUTP2	12		T	URC_SQ_HDOUTP2	12		T
E28	URC_SQ_VCCOB2	12			URC_SQ_VCCOB2	12		
A28	URC_SQ_HDOUTN2	12		C	URC_SQ_HDOUTN2	12		C
B28	URC_SQ_VCCTX2	12			URC_SQ_VCCTX2	12		
A27	URC_SQ_HDOUTN3	12		C	URC_SQ_HDOUTN3	12		C
D26	URC_SQ_VCCOB3	12			URC_SQ_VCCOB3	12		
A26	URC_SQ_HDOUTP3	12		T	URC_SQ_HDOUTP3	12		T
B27	URC_SQ_VCCTX3	12			URC_SQ_VCCTX3	12		
C27	URC_SQ_HDINN3	12		C	URC_SQ_HDINN3	12		C
B26	URC_SQ_VCCIB3	12			URC_SQ_VCCIB3	12		
C26	URC_SQ_HDINP3	12		T	URC_SQ_HDINP3	12		T
D28	URC_SQ_VCCRX3	12			URC_SQ_VCCRX3	12		
E23	PT82B	1		C	PT100B	1		C
GNDIO	GNDIO1	-			GNDIO1	-		
F23	PT82A	1		T	PT100A	1		T
F24	NC	-			PT99B	1		C
G23	NC	-			PT99A	1		T
D23	PT80B	1		C	PT98B	1		C
VCCIO	VCCIO1	1			VCCIO1	1		
D22	PT80A	1		T	PT98A	1		T
-	-	-			GNDIO1	-		
-	-	-			VCCIO1	1		
C21	PT79B	1		C	PT88B	1		C
D21	PT79A	1		T	PT88A	1		T
GNDIO	GNDIO1	-			GNDIO1	-		
B21	PT77B	1		C	PT86B	1		C
A21	PT77A	1		T	PT86A	1		T
F22	PT76B	1		C	PT85B	1		C
E22	PT76A	1		T	PT85A	1		T
VCCIO	VCCIO1	1			VCCIO1	1		
GNDIO	GNDIO1	-			-	-		
J22	NC	-			PT84B	1		C
G22	NC	-			PT84A	1		T
-	-	-			GNDIO1	-		
H22	PT72B	1		C	PT81B	1		C
K22	PT72A	1		T	PT81A	1		T
G21	PT71B	1		C	PT80B	1		C

LFE2M70E/SE and LFE2M100E/SE Logic Signal Connections: 1152 fpBGA

LFE2M70E/SE				LFE2M100E/SE				
Ball Number	Ball/Pad Function	Bank	Dual Function	Differential	Ball/Pad Function	Bank	Dual Function	Differential
VCCIO	VCCIO1	1			VCCIO1	1		
J21	PT71A	1		T	PT80A	1		T
H21	NC	-			PT79B	1		C
K21	NC	-			PT79A	1		T
D20	PT69B	1		C	PT78B	1		C
F20	PT69A	1		T	PT78A	1		T
C20	PT68B	1		C	PT77B	1		C
GNDIO	GNDIO1	-			GNDIO1	-		
E20	PT68A	1		T	PT77A	1		T
G20	PT67B	1		C	PT76B	1		C
VCCIO	VCCIO1	1			VCCIO1	1		
J20	PT67A	1		T	PT76A	1		T
A20	PT66B	1		C	PT75B	1		C
B20	PT66A	1		T	PT75A	1		T
GNDIO	GNDIO1	-			GNDIO1	-		
A19	PT63B	1		C	PT72B	1		C
B19	PT63A	1		T	PT72A	1		T
K20	PT62B	1		C	PT71B	1		C
H20	PT62A	1		T	PT71A	1		T
VCCIO	VCCIO1	1			VCCIO1	1		
L19	NC	-			PT70B	1		C
L20	NC	-			PT70A	1		T
E19	PT60B	1		C	PT69B	1		C
C18	PT60A	1		T	PT69A	1		T
GNDIO	GNDIO1	-			GNDIO1	-		
F19	PT59B	1		C	PT68B	1		C
D18	PT59A	1		T	PT68A	1		T
L18	NC	-			PT67B	1		C
K19	NC	-			PT67A	1		T
VCCIO	VCCIO1	1			VCCIO1	1		
A18	PT57B	1	VREF2_1	C	PT66B	1	VREF2_1	C
B18	PT57A	1	VREF1_1	T	PT66A	1	VREF1_1	T
G18	PT56B	1	PCLKC1_0	C	PT65B	1	PCLKC1_0	C
E18	PT56A	1	PCLKT1_0	T	PT65A	1	PCLKT1_0	T
F18	PT55B	0	PCLKC0_0	C	PT64B	0	PCLKC0_0	C
GNDIO	GNDIO0	-			GNDIO0	-		
G19	PT55A	0	PCLKT0_0	T	PT64A	0	PCLKT0_0	T
H18	PT54B	0	VREF2_0	C	PT63B	0	VREF2_0	C
K18	PT54A	0	VREF1_0	T	PT63A	0	VREF1_0	T
VCCIO	VCCIO0	0			VCCIO0	0		
J18	PT53B	0		C	PT60B	0		C
L17	PT53A	0		T	PT60A	0		T
G17	PT52B	0		C	PT59B	0		C
-	-	-			GNDIO0	-		
J17	PT52A	0		T	PT59A	0		T
H17	PT51B	0		C	PT58B	0		C
-	-	-			VCCIO0	0		
K17	PT51A	0		T	PT58A	0		T
B17	PT50B	0		C	PT57B	0		C
GNDIO	GNDIO0	-			-	-		
A17	PT50A	0		T	PT57A	0		T

LFE2M70E/SE and LFE2M100E/SE Logic Signal Connections: 1152 fpBGA

LFE2M70E/SE				LFE2M100E/SE				
Ball Number	Ball/Pad Function	Bank	Dual Function	Differential	Ball/Pad Function	Bank	Dual Function	Differential
D17	PT49B	0		C	PT56B	0		C
VCCIO	VCCIO0	0			-	-		
F17	PT49A	0		T	PT56A	0		T
B16	PT48B	0		C	PT55B	0		C
A16	PT48A	0		T	PT55A	0		T
-	-	-			GNDIO0	-		
-	-	-			VCCIO0	0		
E17	PT47B	0		C	PT52B	0		C
C17	PT47A	0		T	PT52A	0		T
K16	PT46B	0		C	PT51B	0		C
J15	PT46A	0		T	PT51A	0		T
GNDIO	GNDIO0	-			GNDIO0	-		
G16	PT45B	0		C	PT50B	0		C
H15	PT45A	0		T	PT50A	0		T
A15	PT44B	0		C	PT49B	0		C
B15	PT44A	0		T	PT49A	0		T
VCCIO	VCCIO0	0			VCCIO0	0		
L16	PT43B	0		C	PT48B	0		C
K15	PT43A	0		T	PT48A	0		T
F16	PT42B	0		C	PT47B	0		C
E16	PT42A	0		T	PT47A	0		T
E15	PT41B	0		C	PT46B	0		C
GNDIO	GNDIO0	-			GNDIO0	-		
G15	PT41A	0		T	PT46A	0		T
J14	NC	-			PT45B	0		C
L15	NC	-			PT45A	0		T
H14	NC	-			PT44B	0		C
VCCIO	VCCIO0	0			VCCIO0	0		
K14	NC	-			PT44A	0		T
F15	PT38B	0		C	PT42B	0		C
G14	PT38A	0		T	PT42A	0		T
C15	PT37B	0		C	PT41B	0		C
GNDIO	GNDIO0	-			GNDIO0	-		
D14	PT37A	0		T	PT41A	0		T
G13	PT36B	0		C	PT40B	0		C
-	-	-			VCCIO0	0		
J13	PT36A	0		T	PT40A	0		T
B14	PT35B	0		C	PT39B	0		C
VCCIO	VCCIO0	0			-	-		
A14	PT35A	0		T	PT39A	0		T
F13	PT34B	0		C	PT38B	0		C
H13	PT34A	0		T	PT38A	0		T
D13	PT33B	0		C	PT37B	0		C
C14	PT33A	0		T	PT37A	0		T
GNDIO	GNDIO0	-			GNDIO0	-		
E13	PT32B	0		C	PT32B	0		C
D12	PT32A	0		T	PT32A	0		T
G12	PT31B	0		C	PT31B	0		C
E12	PT31A	0		T	PT31A	0		T
VCCIO	VCCIO0	0			VCCIO0	0		
F12	NC	-			PT30B	0		C

LFE2M70E/SE and LFE2M100E/SE Logic Signal Connections: 1152 fpBGA

LFE2M70E/SE				LFE2M100E/SE				
Ball Number	Ball/Pad Function	Bank	Dual Function	Differential	Ball/Pad Function	Bank	Dual Function	Differential
D11	NC	-			PT30A	0		T
F11	NC	-			PT29B	0		C
E11	NC	-			PT29A	0		T
D7	ULC_SQ_VCCRX0	11			ULC_SQ_VCCRX0	11		
C9	ULC_SQ_HDINP0	11		T	ULC_SQ_HDINP0	11		T
B9	ULC_SQ_VCCIB0	11			ULC_SQ_VCCIB0	11		
C8	ULC_SQ_HDINN0	11		C	ULC_SQ_HDINN0	11		C
B8	ULC_SQ_VCCTX0	11			ULC_SQ_VCCTX0	11		
A9	ULC_SQ_HDOUPT0	11		T	ULC_SQ_HDOUPT0	11		T
D9	ULC_SQ_VCCOB0	11			ULC_SQ_VCCOB0	11		
A8	ULC_SQ_HDOUPT0	11		C	ULC_SQ_HDOUPT0	11		C
B7	ULC_SQ_VCCTX1	11			ULC_SQ_VCCTX1	11		
A7	ULC_SQ_HDOUPT1	11		C	ULC_SQ_HDOUPT1	11		C
E7	ULC_SQ_VCCOB1	11			ULC_SQ_VCCOB1	11		
A6	ULC_SQ_HDOUPT1	11		T	ULC_SQ_HDOUPT1	11		T
B6	ULC_SQ_VCCRX1	11			ULC_SQ_VCCRX1	11		
C7	ULC_SQ_HDINN1	11		C	ULC_SQ_HDINN1	11		C
D8	ULC_SQ_VCCIB1	11			ULC_SQ_VCCIB1	11		
C6	ULC_SQ_HDINP1	11		T	ULC_SQ_HDINP1	11		T
E6	ULC_SQ_VCCAUX33	11			ULC_SQ_VCCAUX33	11		
E5	ULC_SQ_REFCLKN	11		C	ULC_SQ_REFCLKN	11		C
D5	ULC_SQ_REFCLKP	11		T	ULC_SQ_REFCLKP	11		T
D6	ULC_SQ_VCCP	11			ULC_SQ_VCCP	11		
C5	ULC_SQ_HDINP2	11		T	ULC_SQ_HDINP2	11		T
D4	ULC_SQ_VCCIB2	11			ULC_SQ_VCCIB2	11		
C4	ULC_SQ_HDINN2	11		C	ULC_SQ_HDINN2	11		C
B5	ULC_SQ_VCCRX2	11			ULC_SQ_VCCRX2	11		
A5	ULC_SQ_HDOUPT2	11		T	ULC_SQ_HDOUPT2	11		T
D3	ULC_SQ_VCCOB2	11			ULC_SQ_VCCOB2	11		
A4	ULC_SQ_HDOUPT2	11		C	ULC_SQ_HDOUPT2	11		C
B4	ULC_SQ_VCCTX2	11			ULC_SQ_VCCTX2	11		
A3	ULC_SQ_HDOUPT3	11		C	ULC_SQ_HDOUPT3	11		C
C1	ULC_SQ_VCCOB3	11			ULC_SQ_VCCOB3	11		
A2	ULC_SQ_HDOUPT3	11		T	ULC_SQ_HDOUPT3	11		T
B3	ULC_SQ_VCCTX3	11			ULC_SQ_VCCTX3	11		
C3	ULC_SQ_HDINN3	11		C	ULC_SQ_HDINN3	11		C
B1	ULC_SQ_VCCIB3	11			ULC_SQ_VCCIB3	11		
C2	ULC_SQ_HDINP3	11		T	ULC_SQ_HDINP3	11		T
B2	ULC_SQ_VCCRX3	11			ULC_SQ_VCCRX3	11		
AA13	VCC	-			VCC	-		
AA14	VCC	-			VCC	-		
AA15	VCC	-			VCC	-		
AA16	VCC	-			VCC	-		
AA17	VCC	-			VCC	-		
AA18	VCC	-			VCC	-		
AA19	VCC	-			VCC	-		
AA20	VCC	-			VCC	-		
AA21	VCC	-			VCC	-		
AA22	VCC	-			VCC	-		
AB14	VCC	-			VCC	-		
AB15	VCC	-			VCC	-		

LFE2M70E/SE and LFE2M100E/SE Logic Signal Connections: 1152 fpBGA

LFE2M70E/SE				LFE2M100E/SE				
Ball Number	Ball/Pad Function	Bank	Dual Function	Differential	Ball/Pad Function	Bank	Dual Function	Differential
AB20	VCC	-			VCC	-		
AB21	VCC	-			VCC	-		
N14	VCC	-			VCC	-		
N15	VCC	-			VCC	-		
N20	VCC	-			VCC	-		
N21	VCC	-			VCC	-		
P13	VCC	-			VCC	-		
P14	VCC	-			VCC	-		
P15	VCC	-			VCC	-		
P16	VCC	-			VCC	-		
P17	VCC	-			VCC	-		
P18	VCC	-			VCC	-		
P19	VCC	-			VCC	-		
P20	VCC	-			VCC	-		
P21	VCC	-			VCC	-		
P22	VCC	-			VCC	-		
R13	VCC	-			VCC	-		
R14	VCC	-			VCC	-		
R21	VCC	-			VCC	-		
R22	VCC	-			VCC	-		
T14	VCC	-			VCC	-		
T21	VCC	-			VCC	-		
U14	VCC	-			VCC	-		
U21	VCC	-			VCC	-		
V14	VCC	-			VCC	-		
V21	VCC	-			VCC	-		
W14	VCC	-			VCC	-		
W21	VCC	-			VCC	-		
Y13	VCC	-			VCC	-		
Y14	VCC	-			VCC	-		
Y21	VCC	-			VCC	-		
Y22	VCC	-			VCC	-		
C12	VCCIO0	0			VCCIO0	0		
C16	VCCIO0	0			VCCIO0	0		
E14	VCCIO0	0			VCCIO0	0		
H12	VCCIO0	0			VCCIO0	0		
H16	VCCIO0	0			VCCIO0	0		
M14	VCCIO0	0			VCCIO0	0		
M15	VCCIO0	0			VCCIO0	0		
C19	VCCIO1	1			VCCIO1	1		
C23	VCCIO1	1			VCCIO1	1		
E21	VCCIO1	1			VCCIO1	1		
H19	VCCIO1	1			VCCIO1	1		
H23	VCCIO1	1			VCCIO1	1		
M20	VCCIO1	1			VCCIO1	1		
M21	VCCIO1	1			VCCIO1	1		
G32	VCCIO2	2			VCCIO2	2		
K28	VCCIO2	2			VCCIO2	2		
K32	VCCIO2	2			VCCIO2	2		
N27	VCCIO2	2			VCCIO2	2		
N32	VCCIO2	2			VCCIO2	2		

LFE2M70E/SE and LFE2M100E/SE Logic Signal Connections: 1152 fpBGA

LFE2M70E/SE				LFE2M100E/SE				
Ball Number	Ball/Pad Function	Bank	Dual Function	Differential	Ball/Pad Function	Bank	Dual Function	Differential
P23	VCCIO2	2			VCCIO2	2		
R23	VCCIO2	2			VCCIO2	2		
T27	VCCIO2	2			VCCIO2	2		
T32	VCCIO2	2			VCCIO2	2		
AA23	VCCIO3	3			VCCIO3	3		
AB27	VCCIO3	3			VCCIO3	3		
AB32	VCCIO3	3			VCCIO3	3		
AE28	VCCIO3	3			VCCIO3	3		
AE32	VCCIO3	3			VCCIO3	3		
AH32	VCCIO3	3			VCCIO3	3		
W27	VCCIO3	3			VCCIO3	3		
W32	VCCIO3	3			VCCIO3	3		
Y23	VCCIO3	3			VCCIO3	3		
AC20	VCCIO4	4			VCCIO4	4		
AC21	VCCIO4	4			VCCIO4	4		
AG19	VCCIO4	4			VCCIO4	4		
AG23	VCCIO4	4			VCCIO4	4		
AK21	VCCIO4	4			VCCIO4	4		
AM19	VCCIO4	4			VCCIO4	4		
AM23	VCCIO4	4			VCCIO4	4		
AC14	VCCIO5	5			VCCIO5	5		
AC15	VCCIO5	5			VCCIO5	5		
AG12	VCCIO5	5			VCCIO5	5		
AG16	VCCIO5	5			VCCIO5	5		
AK14	VCCIO5	5			VCCIO5	5		
AM12	VCCIO5	5			VCCIO5	5		
AM16	VCCIO5	5			VCCIO5	5		
AA12	VCCIO6	6			VCCIO6	6		
AB3	VCCIO6	6			VCCIO6	6		
AB8	VCCIO6	6			VCCIO6	6		
AE3	VCCIO6	6			VCCIO6	6		
AE7	VCCIO6	6			VCCIO6	6		
AH3	VCCIO6	6			VCCIO6	6		
W3	VCCIO6	6			VCCIO6	6		
W8	VCCIO6	6			VCCIO6	6		
Y12	VCCIO6	6			VCCIO6	6		
G3	VCCIO7	7			VCCIO7	7		
K3	VCCIO7	7			VCCIO7	7		
K7	VCCIO7	7			VCCIO7	7		
N3	VCCIO7	7			VCCIO7	7		
N8	VCCIO7	7			VCCIO7	7		
P12	VCCIO7	7			VCCIO7	7		
R12	VCCIO7	7			VCCIO7	7		
T3	VCCIO7	7			VCCIO7	7		
T8	VCCIO7	7			VCCIO7	7		
AD28	VCCIO8	8			VCCIO8	8		
AG32	VCCIO8	8			VCCIO8	8		
AB12	VCCAUX	-			VCCAUX	-		
AB13	VCCAUX	-			VCCAUX	-		
AB22	VCCAUX	-			VCCAUX	-		
AB23	VCCAUX	-			VCCAUX	-		

LFE2M70E/SE and LFE2M100E/SE Logic Signal Connections: 1152 fpBGA

LFE2M70E/SE				LFE2M100E/SE				
Ball Number	Ball/Pad Function	Bank	Dual Function	Differential	Ball/Pad Function	Bank	Dual Function	Differential
AC13	VCCAUX	-			VCCAUX	-		
AC22	VCCAUX	-			VCCAUX	-		
M13	VCCAUX	-			VCCAUX	-		
M22	VCCAUX	-			VCCAUX	-		
N12	VCCAUX	-			VCCAUX	-		
N13	VCCAUX	-			VCCAUX	-		
N22	VCCAUX	-			VCCAUX	-		
N23	VCCAUX	-			VCCAUX	-		
A1	GND	-			GND	-		
A10	GND	-			GND	-		
A13	GND	-			GND	-		
A22	GND	-			GND	-		
A25	GND	-			GND	-		
A34	GND	-			GND	-		
AB16	GND	-			GND	-		
AB17	GND	-			GND	-		
AB18	GND	-			GND	-		
AB19	GND	-			GND	-		
AB26	GND	-			GND	-		
AB31	GND	-			GND	-		
AB4	GND	-			GND	-		
AB9	GND	-			GND	-		
AC16	GND	-			GND	-		
AC17	GND	-			GND	-		
AC18	GND	-			GND	-		
AC19	GND	-			GND	-		
AD27	GND	-			GND	-		
AE27	GND	-			GND	-		
AE31	GND	-			GND	-		
AE4	GND	-			GND	-		
AE8	GND	-			GND	-		
AF12	GND	-			GND	-		
AF16	GND	-			GND	-		
AF19	GND	-			GND	-		
AF23	GND	-			GND	-		
AG31	GND	-			GND	-		
AH31	GND	-			GND	-		
AH4	GND	-			GND	-		
AJ14	GND	-			GND	-		
AJ21	GND	-			GND	-		
AK27	GND	-			GND	-		
AK8	GND	-			GND	-		
AL10	GND	-			GND	-		
AL16	GND	-			GND	-		
AL19	GND	-			GND	-		
AL2	GND	-			GND	-		
AL25	GND	-			GND	-		
AL33	GND	-			GND	-		
AP1	GND	-			GND	-		
AP10	GND	-			GND	-		
AP13	GND	-			GND	-		

LFE2M70E/SE and LFE2M100E/SE Logic Signal Connections: 1152 fpBGA

LFE2M70E/SE				LFE2M100E/SE				
Ball Number	Ball/Pad Function	Bank	Dual Function	Differential	Ball/Pad Function	Bank	Dual Function	Differential
AP22	GND	-			GND	-		
AP25	GND	-			GND	-		
AP34	GND	-			GND	-		
D10	GND	-			GND	-		
D16	GND	-			GND	-		
D19	GND	-			GND	-		
D2	GND	-			GND	-		
D25	GND	-			GND	-		
D33	GND	-			GND	-		
E27	GND	-			GND	-		
E8	GND	-			GND	-		
F14	GND	-			GND	-		
F21	GND	-			GND	-		
G31	GND	-			GND	-		
G4	GND	-			GND	-		
J12	GND	-			GND	-		
J16	GND	-			GND	-		
J19	GND	-			GND	-		
J23	GND	-			GND	-		
K27	GND	-			GND	-		
K31	GND	-			GND	-		
K4	GND	-			GND	-		
K8	GND	-			GND	-		
M16	GND	-			GND	-		
M17	GND	-			GND	-		
M18	GND	-			GND	-		
M19	GND	-			GND	-		
N16	GND	-			GND	-		
N17	GND	-			GND	-		
N18	GND	-			GND	-		
N19	GND	-			GND	-		
N26	GND	-			GND	-		
N31	GND	-			GND	-		
N4	GND	-			GND	-		
N9	GND	-			GND	-		
R16	GND	-			GND	-		
R17	GND	-			GND	-		
R18	GND	-			GND	-		
R19	GND	-			GND	-		
T12	GND	-			GND	-		
T13	GND	-			GND	-		
T15	GND	-			GND	-		
T16	GND	-			GND	-		
T17	GND	-			GND	-		
T18	GND	-			GND	-		
T19	GND	-			GND	-		
T20	GND	-			GND	-		
T22	GND	-			GND	-		
T23	GND	-			GND	-		
T26	GND	-			GND	-		
T31	GND	-			GND	-		

LFE2M70E/SE and LFE2M100E/SE Logic Signal Connections: 1152 fpBGA

LFE2M70E/SE				LFE2M100E/SE				
Ball Number	Ball/Pad Function	Bank	Dual Function	Differential	Ball/Pad Function	Bank	Dual Function	Differential
T4	GND	-			GND	-		
T9	GND	-			GND	-		
U12	GND	-			GND	-		
U13	GND	-			GND	-		
U15	GND	-			GND	-		
U16	GND	-			GND	-		
U17	GND	-			GND	-		
U18	GND	-			GND	-		
U19	GND	-			GND	-		
U20	GND	-			GND	-		
U22	GND	-			GND	-		
U23	GND	-			GND	-		
V12	GND	-			GND	-		
V13	GND	-			GND	-		
V15	GND	-			GND	-		
V16	GND	-			GND	-		
V17	GND	-			GND	-		
V18	GND	-			GND	-		
V19	GND	-			GND	-		
V20	GND	-			GND	-		
V22	GND	-			GND	-		
V23	GND	-			GND	-		
W12	GND	-			GND	-		
W13	GND	-			GND	-		
W15	GND	-			GND	-		
W16	GND	-			GND	-		
W17	GND	-			GND	-		
W18	GND	-			GND	-		
W19	GND	-			GND	-		
W20	GND	-			GND	-		
W22	GND	-			GND	-		
W23	GND	-			GND	-		
W26	GND	-			GND	-		
W31	GND	-			GND	-		
W4	GND	-			GND	-		
W9	GND	-			GND	-		
Y16	GND	-			GND	-		
Y17	GND	-			GND	-		
Y18	GND	-			GND	-		
Y19	GND	-			GND	-		
A11	NC	-			NC	-		
A12	NC	-			NC	-		
A23	NC	-			NC	-		
A24	NC	-			NC	-		
AA11	NC	-			NC	-		
AB11	NC	-			NC	-		
AC26	NC	-			NC	-		
AC30	NC	-			NC	-		
AD11	NC	-			NC	-		
AD12	NC	-			NC	-		
AD13	NC	-			NC	-		

LFE2M70E/SE and LFE2M100E/SE Logic Signal Connections: 1152 fpBGA

LFE2M70E/SE				LFE2M100E/SE				
Ball Number	Ball/Pad Function	Bank	Dual Function	Differential	Ball/Pad Function	Bank	Dual Function	Differential
AD14	NC	-			NC	-		
AD15	NC	-			NC	-		
AD19	NC	-			NC	-		
AD21	NC	-			NC	-		
AD22	NC	-			NC	-		
AD23	NC	-			NC	-		
AE10	NC	-			NC	-		
AE11	NC	-			NC	-		
AE12	NC	-			NC	-		
AE13	NC	-			NC	-		
AE19	NC	-			NC	-		
AE21	NC	-			NC	-		
AE22	NC	-			NC	-		
AE23	NC	-			NC	-		
AF11	NC	-			NC	-		
AF21	NC	-			NC	-		
AF22	NC	-			NC	-		
AF24	NC	-			NC	-		
AF8	NC	-			NC	-		
AF9	NC	-			NC	-		
AG10	NC	-			NC	-		
AG11	NC	-			NC	-		
AG24	NC	-			NC	-		
AG25	NC	-			NC	-		
AG26	NC	-			NC	-		
AG3	NC	-			NC	-		
AG7	NC	-			NC	-		
AG8	NC	-			NC	-		
AG9	NC	-			NC	-		
AH10	NC	-			NC	-		
AH11	NC	-			NC	-		
AH13	NC	-			NC	-		
AH24	NC	-			NC	-		
AH25	NC	-			NC	-		
AH26	NC	-			NC	-		
AH27	NC	-			NC	-		
AH5	NC	-			NC	-		
AH6	NC	-			NC	-		
AH7	NC	-			NC	-		
AH8	NC	-			NC	-		
AH9	NC	-			NC	-		
AJ10	NC	-			NC	-		
AJ11	NC	-			NC	-		
AJ13	NC	-			NC	-		
AJ24	NC	-			NC	-		
AJ25	NC	-			NC	-		
AJ26	NC	-			NC	-		
AJ27	NC	-			NC	-		
AJ3	NC	-			NC	-		
AJ4	NC	-			NC	-		
AJ5	NC	-			NC	-		

LFE2M70E/SE and LFE2M100E/SE Logic Signal Connections: 1152 fpBGA

LFE2M70E/SE				LFE2M100E/SE				
Ball Number	Ball/Pad Function	Bank	Dual Function	Differential	Ball/Pad Function	Bank	Dual Function	Differential
AJ6	NC	-			NC	-		
AJ7	NC	-			NC	-		
AJ8	NC	-			NC	-		
AJ9	NC	-			NC	-		
AK10	NC	-			NC	-		
AK11	NC	-			NC	-		
AK12	NC	-			NC	-		
AK24	NC	-			NC	-		
AK25	NC	-			NC	-		
AK26	NC	-			NC	-		
AK4	NC	-			NC	-		
AK9	NC	-			NC	-		
AL11	NC	-			NC	-		
AL12	NC	-			NC	-		
AL34	NC	-			NC	-		
AM10	NC	-			NC	-		
AM11	NC	-			NC	-		
AM13	NC	-			NC	-		
AM25	NC	-			NC	-		
AN10	NC	-			NC	-		
AN11	NC	-			NC	-		
AN12	NC	-			NC	-		
AN13	NC	-			NC	-		
AN24	NC	-			NC	-		
AN25	NC	-			NC	-		
AP11	NC	-			NC	-		
AP12	NC	-			NC	-		
AP24	NC	-			NC	-		
B10	NC	-			NC	-		
B11	NC	-			NC	-		
B12	NC	-			NC	-		
B13	NC	-			NC	-		
B22	NC	-			NC	-		
B23	NC	-			NC	-		
B24	NC	-			NC	-		
B25	NC	-			NC	-		
C10	NC	-			NC	-		
C11	NC	-			NC	-		
C13	NC	-			NC	-		
C22	NC	-			NC	-		
C24	NC	-			NC	-		
C25	NC	-			NC	-		
D1	NC	-			NC	-		
D15	NC	-			NC	-		
D24	NC	-			NC	-		
D34	NC	-			NC	-		
E10	NC	-			NC	-		
E24	NC	-			NC	-		
E25	NC	-			NC	-		
E26	NC	-			NC	-		
E3	NC	-			NC	-		

LFE2M70E/SE and LFE2M100E/SE Logic Signal Connections: 1152 fpBGA

LFE2M70E/SE				LFE2M100E/SE				
Ball Number	Ball/Pad Function	Bank	Dual Function	Differential	Ball/Pad Function	Bank	Dual Function	Differential
E31	NC	-			NC	-		
E32	NC	-			NC	-		
E33	NC	-			NC	-		
E34	NC	-			NC	-		
E4	NC	-			NC	-		
E9	NC	-			NC	-		
F10	NC	-			NC	-		
F25	NC	-			NC	-		
F26	NC	-			NC	-		
F27	NC	-			NC	-		
F28	NC	-			NC	-		
F29	NC	-			NC	-		
F30	NC	-			NC	-		
F31	NC	-			NC	-		
F32	NC	-			NC	-		
F33	NC	-			NC	-		
F34	NC	-			NC	-		
F5	NC	-			NC	-		
F6	NC	-			NC	-		
F7	NC	-			NC	-		
F8	NC	-			NC	-		
F9	NC	-			NC	-		
G10	NC	-			NC	-		
G11	NC	-			NC	-		
G24	NC	-			NC	-		
G25	NC	-			NC	-		
G26	NC	-			NC	-		
G27	NC	-			NC	-		
G28	NC	-			NC	-		
G29	NC	-			NC	-		
G30	NC	-			NC	-		
G33	NC	-			NC	-		
G34	NC	-			NC	-		
G7	NC	-			NC	-		
G8	NC	-			NC	-		
G9	NC	-			NC	-		
H10	NC	-			NC	-		
H11	NC	-			NC	-		
H24	NC	-			NC	-		
H25	NC	-			NC	-		
H26	NC	-			NC	-		
H27	NC	-			NC	-		
H28	NC	-			NC	-		
H29	NC	-			NC	-		
H8	NC	-			NC	-		
H9	NC	-			NC	-		
J10	NC	-			NC	-		
J11	NC	-			NC	-		
J24	NC	-			NC	-		
J25	NC	-			NC	-		
J26	NC	-			NC	-		

LFE2M70E/SE and LFE2M100E/SE Logic Signal Connections: 1152 fpBGA

LFE2M70E/SE				LFE2M100E/SE				
Ball Number	Ball/Pad Function	Bank	Dual Function	Differential	Ball/Pad Function	Bank	Dual Function	Differential
J9	NC	-			NC	-		
K10	NC	-			NC	-		
K11	NC	-			NC	-		
K12	NC	-			NC	-		
K13	NC	-			NC	-		
K23	NC	-			NC	-		
K24	NC	-			NC	-		
K25	NC	-			NC	-		
K26	NC	-			NC	-		
L11	NC	-			NC	-		
L12	NC	-			NC	-		
L13	NC	-			NC	-		
L14	NC	-			NC	-		
L21	NC	-			NC	-		
L22	NC	-			NC	-		
L23	NC	-			NC	-		
L24	NC	-			NC	-		
L25	NC	-			NC	-		
L26	NC	-			NC	-		
M11	NC	-			NC	-		
M24	NC	-			NC	-		
M25	NC	-			NC	-		
M6	NC	-			NC	-		
M8	NC	-			NC	-		
N10	NC	-			NC	-		
N11	NC	-			NC	-		
P10	NC	-			NC	-		
P25	NC	-			NC	-		
P26	NC	-			NC	-		
R9	NC	-			NC	-		
T11	NC	-			NC	-		
U11	NC	-			NC	-		
W11	NC	-			NC	-		
Y10	NC	-			NC	-		
Y11	NC	-			NC	-		
R15	VCCPLL	-			VCCPLL	-		
R20	VCCPLL	-			VCCPLL	-		
Y15	VCCPLL	-			VCCPLL	-		
Y20	VCCPLL	-			VCCPLL	-		

* Supports true LVDS. Other differential signals must be emulated with external resistors.

** These dedicated input pins can be used for GPLLs or GDLLs within the respective quadrant.

*** For density migration, board design must take into account that these sysCONFIG pins are dual function for the lower density devices (ECP2M20 and ECP2M35) and are dedicated pins for the higher density devices (ECP2M50, ECP2M70, and ECP2M100).

****Due to packaging bond out option, this DQS does not have all the necessary DQ pins bonded out for a full 8-bit data width.

Note: VCCIO and GND pads are used to determine the average DC current drawn by I/Os between GND/VCCIO connections, or between the last GND/VCCIO in an I/O bank and the end of an I/O bank. The substrate pads listed in the Pin Table do not necessarily have a one to one connection with a package ball or pin.

LatticeECP2 Part Number Description

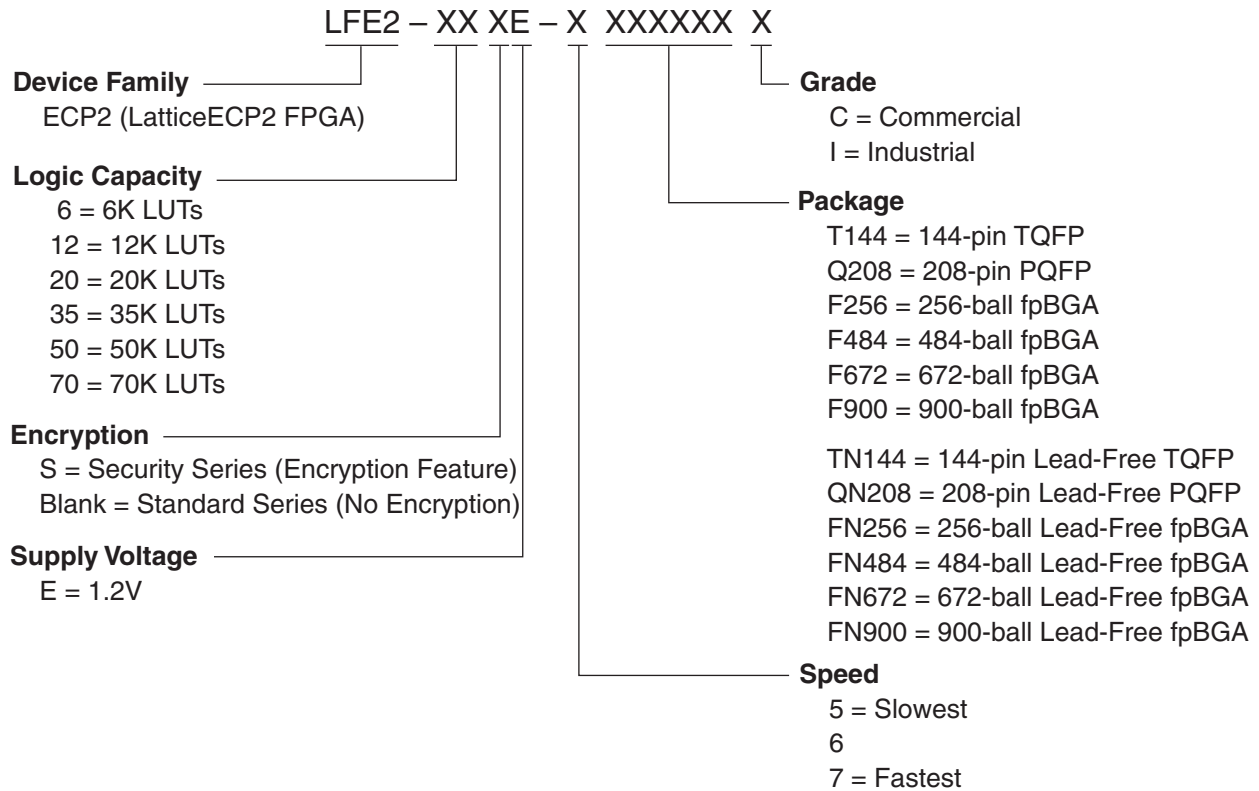

Ordering Information

Note: LatticeECP2 devices are dual marked. For example, the commercial speed grade LFE2-50E-7F672C is also marked with industrial grade -6I (LFE2-50E-6F672I). The commercial grade is one speed grade faster than the associated dual mark industrial grade. The slowest commercial speed grade does not have industrial markings. The markings appear as follows:

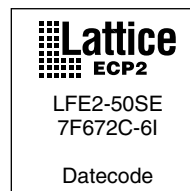
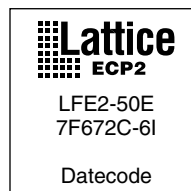

LatticeECP2 Standard Series Devices, Conventional Packaging**Commercial**

Part Number	I/Os	Voltage	Grade	Package	Pins	Temp.	LUTs (K)
LFE2-6E-5T144C	90	1.2V	-5	TQFP	144	COM	6
LFE2-6E-6T144C	90	1.2V	-6	TQFP	144	COM	6
LFE2-6E-7T144C	90	1.2V	-7	TQFP	144	COM	6
LFE2-6E-5F256C	190	1.2V	-5	fpBGA	256	COM	6
LFE2-6E-6F256C	190	1.2V	-6	fpBGA	256	COM	6
LFE2-6E-7F256C	190	1.2V	-7	fpBGA	256	COM	6

Part Number	I/Os	Voltage	Grade	Package	Pins	Temp.	LUTs (K)
LFE2-12E-5T144C	93	1.2V	-5	TQFP	144	COM	12
LFE2-12E-6T144C	93	1.2V	-6	TQFP	144	COM	12
LFE2-12E-7T144C	93	1.2V	-7	TQFP	144	COM	12
LFE2-12E-5Q208C	131	1.2V	-5	PQFP	208	COM	12
LFE2-12E-6Q208C	131	1.2V	-6	PQFP	208	COM	12
LFE2-12E-7Q208C	131	1.2V	-7	PQFP	208	COM	12
LFE2-12E-5F256C	193	1.2V	-5	fpBGA	256	COM	12
LFE2-12E-6F256C	193	1.2V	-6	fpBGA	256	COM	12
LFE2-12E-7F256C	193	1.2V	-7	fpBGA	256	COM	12
LFE2-12E-5F484C	297	1.2V	-5	fpBGA	484	COM	12
LFE2-12E-6F484C	297	1.2V	-6	fpBGA	484	COM	12
LFE2-12E-7F484C	297	1.2V	-7	fpBGA	484	COM	12

Part Number	I/Os	Voltage	Grade	Package	Pins	Temp.	LUTs (K)
LFE2-20E-5Q208C	131	1.2V	-5	PQFP	208	COM	20
LFE2-20E-6Q208C	131	1.2V	-6	PQFP	208	COM	20
LFE2-20E-7Q208C	131	1.2V	-7	PQFP	208	COM	20
LFE2-20E-5F256C	193	1.2V	-5	fpBGA	256	COM	20
LFE2-20E-6F256C	193	1.2V	-6	fpBGA	256	COM	20
LFE2-20E-7F256C	193	1.2V	-7	fpBGA	256	COM	20
LFE2-20E-5F484C	331	1.2V	-5	fpBGA	484	COM	20
LFE2-20E-6F484C	331	1.2V	-6	fpBGA	484	COM	20
LFE2-20E-7F484C	331	1.2V	-7	fpBGA	484	COM	20
LFE2-20E-5F672C	402	1.2V	-5	fpBGA	672	COM	20
LFE2-20E-6F672C	402	1.2V	-6	fpBGA	672	COM	20
LFE2-20E-7F672C	402	1.2V	-7	fpBGA	672	COM	20

Part Number	I/Os	Voltage	Grade	Package	Pins	Temp.	LUTs (K)
LFE2-35E-5F484C	331	1.2V	-5	fpBGA	484	COM	35
LFE2-35E-6F484C	331	1.2V	-6	fpBGA	484	COM	35
LFE2-35E-7F484C	331	1.2V	-7	fpBGA	484	COM	35
LFE2-35E-5F672C	450	1.2V	-5	fpBGA	672	COM	35
LFE2-35E-6F672C	450	1.2V	-6	fpBGA	672	COM	35
LFE2-35E-7F672C	450	1.2V	-7	fpBGA	672	COM	35

Part Number	I/Os	Voltage	Grade	Package	Pins	Temp.	LUTs (K)
LFE2-50E-5F484C	339	1.2V	-5	fpBGA	484	COM	50
LFE2-50E-6F484C	339	1.2V	-6	fpBGA	484	COM	50
LFE2-50E-7F484C	339	1.2V	-7	fpBGA	484	COM	50
LFE2-50E-5F672C	500	1.2V	-5	fpBGA	672	COM	50
LFE2-50E-6F672C	500	1.2V	-6	fpBGA	672	COM	50
LFE2-50E-7F672C	500	1.2V	-7	fpBGA	672	COM	50

Part Number	I/Os	Voltage	Grade	Package	Pins	Temp.	LUTs (K)
LFE2-70E-5F672C	500	1.2V	-5	fpBGA	672	COM	70
LFE2-70E-6F672C	500	1.2V	-6	fpBGA	672	COM	70
LFE2-70E-7F672C	500	1.2V	-7	fpBGA	672	COM	70
LFE2-70E-5F900C	583	1.2V	-5	fpBGA	900	COM	70
LFE2-70E-6F900C	583	1.2V	-6	fpBGA	900	COM	70
LFE2-70E-7F900C	583	1.2V	-7	fpBGA	900	COM	70

Industrial

Part Number	I/Os	Voltage	Grade	Package	Pins	Temp.	LUTs (K)
LFE2-6E-5T144I	90	1.2V	-5	TQFP	144	IND	6
LFE2-6E-6T144I	90	1.2V	-6	TQFP	144	IND	6
LFE2-6E-5F256I	190	1.2V	-5	fpBGA	256	IND	6
LFE2-6E-6F256I	190	1.2V	-6	fpBGA	256	IND	6

Part Number	I/Os	Voltage	Grade	Package	Pins	Temp.	LUTs (K)
LFE2-12E-5T144I	93	1.2V	-5	TQFP	144	IND	12
LFE2-12E-6T144I	93	1.2V	-6	TQFP	144	IND	12
LFE2-12E-5Q208I	131	1.2V	-5	PQFP	208	IND	12
LFE2-12E-6Q208I	131	1.2V	-6	PQFP	208	IND	12
LFE2-12E-5F256I	193	1.2V	-5	fpBGA	256	IND	12
LFE2-12E-6F256I	193	1.2V	-6	fpBGA	256	IND	12
LFE2-12E-5F484I	297	1.2V	-5	fpBGA	484	IND	12
LFE2-12E-6F484I	297	1.2V	-6	fpBGA	484	IND	12

Part Number	I/Os	Voltage	Grade	Package	Pins	Temp.	LUTs (K)
LFE2-20E-5Q208I	131	1.2V	-5	PQFP	208	IND	20
LFE2-20E-6Q208I	131	1.2V	-6	PQFP	208	IND	20
LFE2-20E-5F256I	193	1.2V	-5	fpBGA	256	IND	20
LFE2-20E-6F256I	193	1.2V	-6	fpBGA	256	IND	20
LFE2-20E-5F484I	331	1.2V	-5	fpBGA	484	IND	20
LFE2-20E-6F484I	331	1.2V	-6	fpBGA	484	IND	20
LFE2-20E-5F672I	402	1.2V	-5	fpBGA	672	IND	20
LFE2-20E-6F672I	402	1.2V	-6	fpBGA	672	IND	20

Part Number	I/Os	Voltage	Grade	Package	Pins	Temp.	LUTs (K)
LFE2-35E-5F484I	331	1.2V	-5	fpBGA	484	IND	35
LFE2-35E-6F484I	331	1.2V	-6	fpBGA	484	IND	35
LFE2-35E-5F672I	450	1.2V	-5	fpBGA	672	IND	35
LFE2-35E-6F672I	450	1.2V	-6	fpBGA	672	IND	35

Part Number	I/Os	Voltage	Grade	Package	Pins	Temp.	LUTs (K)
LFE2-50E-5F484I	339	1.2V	-5	fpBGA	484	IND	50
LFE2-50E-6F484I	339	1.2V	-6	fpBGA	484	IND	50
LFE2-50E-5F672I	500	1.2V	-5	fpBGA	672	IND	50
LFE2-50E-6F672I	500	1.2V	-6	fpBGA	672	IND	50

Part Number	I/Os	Voltage	Grade	Package	Pins	Temp.	LUTs (K)
LFE2-70E-5F672I	500	1.2V	-5	fpBGA	672	IND	70
LFE2-70E-6F672I	500	1.2V	-6	fpBGA	672	IND	70
LFE2-70E-5F900I	583	1.2V	-5	fpBGA	900	IND	70
LFE2-70E-6F900I	583	1.2V	-6	fpBGA	900	IND	70

LatticeECP2 Standard Series Devices, Lead-Free Packaging**Commercial**

Part Number	I/Os	Voltage	Grade	Package	Pins	Temp.	LUTs (K)
LFE2-6E-5TN144C	90	1.2V	-5	Lead-Free TQFP	144	COM	6
LFE2-6E-6TN144C	90	1.2V	-6	Lead-Free TQFP	144	COM	6
LFE2-6E-7TN144C	90	1.2V	-7	Lead-Free TQFP	144	COM	6
LFE2-6E-5FN256C	190	1.2V	-5	Lead-Free fpBGA	256	COM	6
LFE2-6E-6FN256C	190	1.2V	-6	Lead-Free fpBGA	256	COM	6
LFE2-6E-7FN256C	190	1.2V	-7	Lead-Free fpBGA	256	COM	6

Part Number	I/Os	Voltage	Grade	Package	Pins	Temp.	LUTs (K)
LFE2-12E-5TN144C	93	1.2V	-5	Lead-Free TQFP	144	COM	12
LFE2-12E-6TN144C	93	1.2V	-6	Lead-Free TQFP	144	COM	12
LFE2-12E-7TN144C	93	1.2V	-7	Lead-Free TQFP	144	COM	12
LFE2-12E-5QN208C	131	1.2V	-5	Lead-Free PQFP	208	COM	12
LFE2-12E-6QN208C	131	1.2V	-6	Lead-Free PQFP	208	COM	12
LFE2-12E-7QN208C	131	1.2V	-7	Lead-Free PQFP	208	COM	12
LFE2-12E-5FN256C	193	1.2V	-5	Lead-Free fpBGA	256	COM	12
LFE2-12E-6FN256C	193	1.2V	-6	Lead-Free fpBGA	256	COM	12
LFE2-12E-7FN256C	193	1.2V	-7	Lead-Free fpBGA	256	COM	12
LFE2-12E-5FN484C	297	1.2V	-5	Lead-Free fpBGA	484	COM	12
LFE2-12E-6FN484C	297	1.2V	-6	Lead-Free fpBGA	484	COM	12
LFE2-12E-7FN484C	297	1.2V	-7	Lead-Free fpBGA	484	COM	12

Part Number	I/Os	Voltage	Grade	Package	Pins	Temp.	LUTs (K)
LFE2-20E-5QN208C	131	1.2V	-5	Lead-Free PQFP	208	COM	20
LFE2-20E-6QN208C	131	1.2V	-6	Lead-Free PQFP	208	COM	20
LFE2-20E-7QN208C	131	1.2V	-7	Lead-Free PQFP	208	COM	20
LFE2-20E-5FN256C	193	1.2V	-5	Lead-Free fpBGA	256	COM	20
LFE2-20E-6FN256C	193	1.2V	-6	Lead-Free fpBGA	256	COM	20
LFE2-20E-7FN256C	193	1.2V	-7	Lead-Free fpBGA	256	COM	20
LFE2-20E-5FN484C	331	1.2V	-5	Lead-Free fpBGA	484	COM	20
LFE2-20E-6FN484C	331	1.2V	-6	Lead-Free fpBGA	484	COM	20
LFE2-20E-7FN484C	331	1.2V	-7	Lead-Free fpBGA	484	COM	20
LFE2-20E-5FN672C	402	1.2V	-5	Lead-Free fpBGA	672	COM	20
LFE2-20E-6FN672C	402	1.2V	-6	Lead-Free fpBGA	672	COM	20
LFE2-20E-7FN672C	402	1.2V	-7	Lead-Free fpBGA	672	COM	20

Part Number	I/Os	Voltage	Grade	Package	Pins	Temp.	LUTs (K)
LFE2-35E-5FN484C	331	1.2V	-5	Lead-Free fpBGA	484	COM	35
LFE2-35E-6FN484C	331	1.2V	-6	Lead-Free fpBGA	484	COM	35
LFE2-35E-7FN484C	331	1.2V	-7	Lead-Free fpBGA	484	COM	35
LFE2-35E-5FN672C	450	1.2V	-5	Lead-Free fpBGA	672	COM	35
LFE2-35E-6FN672C	450	1.2V	-6	Lead-Free fpBGA	672	COM	35
LFE2-35E-7FN672C	450	1.2V	-7	Lead-Free fpBGA	672	COM	35

Part Number	I/Os	Voltage	Grade	Package	Pins	Temp.	LUTs (K)
LFE2-50E-5FN484C	339	1.2V	-5	Lead-Free fpBGA	484	COM	50
LFE2-50E-6FN484C	339	1.2V	-6	Lead-Free fpBGA	484	COM	50
LFE2-50E-7FN484C	339	1.2V	-7	Lead-Free fpBGA	484	COM	50
LFE2-50E-5FN672C	500	1.2V	-5	Lead-Free fpBGA	672	COM	50
LFE2-50E-6FN672C	500	1.2V	-6	Lead-Free fpBGA	672	COM	50
LFE2-50E-7FN672C	500	1.2V	-7	Lead-Free fpBGA	672	COM	50

Part Number	I/Os	Voltage	Grade	Package	Pins	Temp.	LUTs (K)
LFE2-70E-5FN672C	500	1.2V	-5	Lead-Free fpBGA	672	COM	70
LFE2-70E-6FN672C	500	1.2V	-6	Lead-Free fpBGA	672	COM	70
LFE2-70E-7FN672C	500	1.2V	-7	Lead-Free fpBGA	672	COM	70
LFE2-70E-5FN900C	583	1.2V	-5	Lead-Free fpBGA	900	COM	70
LFE2-70E-6FN900C	583	1.2V	-6	Lead-Free fpBGA	900	COM	70
LFE2-70E-7FN900C	583	1.2V	-7	Lead-Free fpBGA	900	COM	70

Industrial

Part Number	I/Os	Voltage	Grade	Package	Pins	Temp.	LUTs (K)
LFE2-6E-5TN144I	90	1.2V	-5	Lead-Free TQFP	144	IND	6
LFE2-6E-6TN144I	90	1.2V	-6	Lead-Free TQFP	144	IND	6
LFE2-6E-5FN256I	190	1.2V	-5	Lead-Free fpBGA	256	IND	6
LFE2-6E-6FN256I	190	1.2V	-6	Lead-Free fpBGA	256	IND	6

Part Number	I/Os	Voltage	Grade	Package	Pins	Temp.	LUTs (K)
LFE2-12E-5TN144I	93	1.2V	-5	Lead-Free TQFP	144	IND	12
LFE2-12E-6TN144I	93	1.2V	-6	Lead-Free TQFP	144	IND	12
LFE2-12E-5QN208I	131	1.2V	-5	Lead-Free PQFP	208	IND	12
LFE2-12E-6QN208I	131	1.2V	-6	Lead-Free PQFP	208	IND	12
LFE2-12E-5FN256I	193	1.2V	-5	Lead-Free fpBGA	256	IND	12
LFE2-12E-6FN256I	193	1.2V	-6	Lead-Free fpBGA	256	IND	12
LFE2-12E-5FN484I	297	1.2V	-5	Lead-Free fpBGA	484	IND	12
LFE2-12E-6FN484I	297	1.2V	-6	Lead-Free fpBGA	484	IND	12

Part Number	I/Os	Voltage	Grade	Package	Pins	Temp.	LUTs (K)
LFE2-20E-5QN208I	131	1.2V	-5	Lead-Free PQFP	208	IND	20
LFE2-20E-6QN208I	131	1.2V	-6	Lead-Free PQFP	208	IND	20
LFE2-20E-5FN256I	193	1.2V	-5	Lead-Free fpBGA	256	IND	20
LFE2-20E-6FN256I	193	1.2V	-6	Lead-Free fpBGA	256	IND	20
LFE2-20E-5FN484I	331	1.2V	-5	Lead-Free fpBGA	484	IND	20
LFE2-20E-6FN484I	331	1.2V	-6	Lead-Free fpBGA	484	IND	20
LFE2-20E-5FN672I	402	1.2V	-5	Lead-Free fpBGA	672	IND	20
LFE2-20E-6FN672I	402	1.2V	-6	Lead-Free fpBGA	672	IND	20

Part Number	I/Os	Voltage	Grade	Package	Pins	Temp.	LUTs (K)
LFE2-35E-5FN484I	331	1.2V	-5	Lead-Free fpBGA	484	IND	35
LFE2-35E-6FN484I	331	1.2V	-6	Lead-Free fpBGA	484	IND	35
LFE2-35E-5FN672I	450	1.2V	-5	Lead-Free fpBGA	672	IND	35
LFE2-35E-6FN672I	450	1.2V	-6	Lead-Free fpBGA	672	IND	35

Part Number	I/Os	Voltage	Grade	Package	Pins	Temp.	LUTs (K)
LFE2-50E-5FN484I	339	1.2V	-5	Lead-Free fpBGA	484	IND	50
LFE2-50E-6FN484I	339	1.2V	-6	Lead-Free fpBGA	484	IND	50
LFE2-50E-5FN672I	500	1.2V	-5	Lead-Free fpBGA	672	IND	50
LFE2-50E-6FN672I	500	1.2V	-6	Lead-Free fpBGA	672	IND	50

Part Number	I/Os	Voltage	Grade	Package	Pins	Temp.	LUTs (K)
LFE2-70E-5FN672I	500	1.2V	-5	Lead-Free fpBGA	672	IND	70
LFE2-70E-6FN672I	500	1.2V	-6	Lead-Free fpBGA	672	IND	70
LFE2-70E-5FN900I	583	1.2V	-5	Lead-Free fpBGA	900	IND	70
LFE2-70E-6FN900I	583	1.2V	-6	Lead-Free fpBGA	900	IND	70

LatticeECP2 S-Series Devices, Conventional Packaging**Commercial**

Part Number	I/Os	Voltage	Grade	Package	Pins	Temp.	LUTs (K)
LFE2-6SE-5T144C	90	1.2V	-5	TQFP	144	Com	6
LFE2-6SE-6T144C	90	1.2V	-6	TQFP	144	Com	6
LFE2-6SE-7T144C	90	1.2V	-7	TQFP	144	Com	6
LFE2-6SE-5F256C	190	1.2V	-5	fpBGA	256	Com	6
LFE2-6SE-6F256C	190	1.2V	-6	fpBGA	256	Com	6
LFE2-6SE-7F256C	190	1.2V	-7	fpBGA	256	Com	6

Part Number	I/Os	Voltage	Grade	Package	Pins	Temp.	LUTs (K)
LFE2-12SE-5T144C	93	1.2V	-5	TQFP	144	Com	12
LFE2-12SE-6T144C	93	1.2V	-6	TQFP	144	Com	12
LFE2-12SE-7T144C	93	1.2V	-7	TQFP	144	Com	12
LFE2-12SE-5Q208C	131	1.2V	-5	PQFP	208	Com	12
LFE2-12SE-6Q208C	131	1.2V	-6	PQFP	208	Com	12
LFE2-12SE-7Q208C	131	1.2V	-7	PQFP	208	Com	12
LFE2-12SE-5F256C	193	1.2V	-5	fpBGA	256	Com	12
LFE2-12SE-6F256C	193	1.2V	-6	fpBGA	256	Com	12
LFE2-12SE-7F256C	193	1.2V	-7	fpBGA	256	Com	12
LFE2-12SE-5F484C	297	1.2V	-5	fpBGA	484	Com	12
LFE2-12SE-6F484C	297	1.2V	-6	fpBGA	484	Com	12
LFE2-12SE-7F484C	297	1.2V	-7	fpBGA	484	Com	12

Part Number	I/Os	Voltage	Grade	Package	Pins	Temp.	LUTs (K)
LFE2-20SE-5Q208C	131	1.2V	-5	PQFP	208	Com	20
LFE2-20SE-6Q208C	131	1.2V	-6	PQFP	208	Com	20
LFE2-20SE-7Q208C	131	1.2V	-7	PQFP	208	Com	20
LFE2-20SE-5F256C	193	1.2V	-5	fpBGA	256	Com	20
LFE2-20SE-6F256C	193	1.2V	-6	fpBGA	256	Com	20
LFE2-20SE-7F256C	193	1.2V	-7	fpBGA	256	Com	20
LFE2-20SE-5F484C	331	1.2V	-5	fpBGA	484	Com	20
LFE2-20SE-6F484C	331	1.2V	-6	fpBGA	484	Com	20
LFE2-20SE-7F484C	331	1.2V	-7	fpBGA	484	Com	20
LFE2-20SE-5F672C	402	1.2V	-5	fpBGA	672	Com	20
LFE2-20SE-6F672C	402	1.2V	-6	fpBGA	672	Com	20
LFE2-20SE-7F672C	402	1.2V	-7	fpBGA	672	Com	20

Part Number	I/Os	Voltage	Grade	Package	Pins	Temp.	LUTs (K)
LFE2-35SE-5F484C	331	1.2V	-5	fpBGA	484	Com	35
LFE2-35SE-6F484C	331	1.2V	-6	fpBGA	484	Com	35
LFE2-35SE-7F484C	331	1.2V	-7	fpBGA	484	Com	35
LFE2-35SE-5F672C	450	1.2V	-5	fpBGA	672	Com	35
LFE2-35SE-6F672C	450	1.2V	-6	fpBGA	672	Com	35
LFE2-35SE-7F672C	450	1.2V	-7	fpBGA	672	Com	35

Part Number	I/Os	Voltage	Grade	Package	Pins	Temp.	LUTs (K)
LFE2-50SE-5F484C	339	1.2V	-5	fpBGA	484	Com	50
LFE2-50SE-6F484C	339	1.2V	-6	fpBGA	484	Com	50
LFE2-50SE-7F484C	339	1.2V	-7	fpBGA	484	Com	50
LFE2-50SE-5F672C	500	1.2V	-5	fpBGA	672	Com	50
LFE2-50SE-6F672C	500	1.2V	-6	fpBGA	672	Com	50
LFE2-50SE-7F672C	500	1.2V	-7	fpBGA	672	Com	50

Part Number	I/Os	Voltage	Grade	Package	Pins	Temp.	LUTs (K)
LFE2-70SE-5F672C	500	1.2V	-5	fpBGA	672	Com	70
LFE2-70SE-6F672C	500	1.2V	-6	fpBGA	672	Com	70
LFE2-70SE-7F672C	500	1.2V	-7	fpBGA	672	Com	70
LFE2-70SE-5F900C	583	1.2V	-5	fpBGA	900	Com	70
LFE2-70SE-6F900C	583	1.2V	-6	fpBGA	900	Com	70
LFE2-70SE-7F900C	583	1.2V	-7	fpBGA	900	Com	70

Industrial

Part Number	I/Os	Voltage	Grade	Package	Pins	Temp.	LUTs (K)
LFE2-6SE-5T144I	90	1.2V	-5	TQFP	144	Ind	6
LFE2-6SE-6T144I	90	1.2V	-6	TQFP	144	Ind	6
LFE2-6SE-5F256I	190	1.2V	-5	fpBGA	256	Ind	6
LFE2-6SE-6F256I	190	1.2V	-6	fpBGA	256	Ind	6

Part Number	I/Os	Voltage	Grade	Package	Pins	Temp.	LUTs (K)
LFE2-12SE-5T144I	93	1.2V	-5	TQFP	144	Ind	12
LFE2-12SE-6T144I	93	1.2V	-6	TQFP	144	Ind	12
LFE2-12SE-5Q208I	131	1.2V	-5	PQFP	208	Ind	12
LFE2-12SE-6Q208I	131	1.2V	-6	PQFP	208	Ind	12
LFE2-12SE-5F256I	193	1.2V	-5	fpBGA	256	Ind	12
LFE2-12SE-6F256I	193	1.2V	-6	fpBGA	256	Ind	12
LFE2-12SE-5F484I	297	1.2V	-5	fpBGA	484	Ind	12
LFE2-12SE-6F484I	297	1.2V	-6	fpBGA	484	Ind	12

Part Number	I/Os	Voltage	Grade	Package	Pins	Temp.	LUTs (K)
LFE2-20SE-5Q208I	131	1.2V	-5	PQFP	208	Ind	20
LFE2-20SE-6Q208I	131	1.2V	-6	PQFP	208	Ind	20
LFE2-20SE-5F256I	193	1.2V	-5	fpBGA	256	Ind	20
LFE2-20SE-6F256I	193	1.2V	-6	fpBGA	256	Ind	20
LFE2-20SE-5F484I	331	1.2V	-5	fpBGA	484	Ind	20
LFE2-20SE-6F484I	331	1.2V	-6	fpBGA	484	Ind	20
LFE2-20SE-5F672I	402	1.2V	-5	fpBGA	672	Ind	20
LFE2-20SE-6F672I	402	1.2V	-6	fpBGA	672	Ind	20

Part Number	I/Os	Voltage	Grade	Package	Pins	Temp.	LUTs (K)
LFE2-35SE-5F484I	331	1.2V	-5	fpBGA	484	Ind	35
LFE2-35SE-6F484I	331	1.2V	-6	fpBGA	484	Ind	35
LFE2-35SE-5F672I	450	1.2V	-5	fpBGA	672	Ind	35
LFE2-35SE-6F672I	450	1.2V	-6	fpBGA	672	Ind	35

Part Number	I/Os	Voltage	Grade	Package	Pins	Temp.	LUTs (K)
LFE2-50SE-5F484I	339	1.2V	-5	fpBGA	484	Ind	50
LFE2-50SE-6F484I	339	1.2V	-6	fpBGA	484	Ind	50
LFE2-50SE-5F672I	500	1.2V	-5	fpBGA	672	Ind	50
LFE2-50SE-6F672I	500	1.2V	-6	fpBGA	672	Ind	50

Part Number	I/Os	Voltage	Grade	Package	Pins	Temp.	LUTs (K)
LFE2-70SE-5F672I	500	1.2V	-5	fpBGA	672	Ind	70
LFE2-70SE-6F672I	500	1.2V	-6	fpBGA	672	Ind	70
LFE2-70SE-5F900I	583	1.2V	-5	fpBGA	900	Ind	70
LFE2-70SE-6F900I	583	1.2V	-6	fpBGA	900	Ind	70

LatticeECP2 S-Series Devices, Lead-Free Packaging**Commercial**

Part Number	I/Os	Voltage	Grade	Package	Pins	Temp.	LUTs (K)
LFE2-6SE-5TN144C	90	1.2V	-5	Lead-Free TQFP	144	Com	6
LFE2-6SE-6TN144C	90	1.2V	-6	Lead-Free TQFP	144	Com	6
LFE2-6SE-7TN144C	90	1.2V	-7	Lead-Free TQFP	144	Com	6
LFE2-6SE-5FN256C	190	1.2V	-5	Lead-Free fpBGA	256	Com	6
LFE2-6SE-6FN256C	190	1.2V	-6	Lead-Free fpBGA	256	Com	6
LFE2-6SE-7FN256C	190	1.2V	-7	Lead-Free fpBGA	256	Com	6

Part Number	I/Os	Voltage	Grade	Package	Pins	Temp.	LUTs (K)
LFE2-12SE-5TN144C	93	1.2V	-5	Lead-Free TQFP	144	Com	12
LFE2-12SE-6TN144C	93	1.2V	-6	Lead-Free TQFP	144	Com	12
LFE2-12SE-7TN144C	93	1.2V	-7	Lead-Free TQFP	144	Com	12
LFE2-12SE-5QN208C	131	1.2V	-5	Lead-Free PQFP	208	Com	12
LFE2-12SE-6QN208C	131	1.2V	-6	Lead-Free PQFP	208	Com	12
LFE2-12SE-7QN208C	131	1.2V	-7	Lead-Free PQFP	208	Com	12
LFE2-12SE-5FN256C	193	1.2V	-5	Lead-Free fpBGA	256	Com	12
LFE2-12SE-6FN256C	193	1.2V	-6	Lead-Free fpBGA	256	Com	12
LFE2-12SE-7FN256C	193	1.2V	-7	Lead-Free fpBGA	256	Com	12
LFE2-12SE-5FN484C	297	1.2V	-5	Lead-Free fpBGA	484	Com	12
LFE2-12SE-6FN484C	297	1.2V	-6	Lead-Free fpBGA	484	Com	12
LFE2-12SE-7FN484C	297	1.2V	-7	Lead-Free fpBGA	484	Com	12

Part Number	I/Os	Voltage	Grade	Package	Pins	Temp.	LUTs (K)
LFE2-20SE-5QN208C	131	1.2V	-5	Lead-Free PQFP	208	Com	20
LFE2-20SE-6QN208C	131	1.2V	-6	Lead-Free PQFP	208	Com	20
LFE2-20SE-7QN208C	131	1.2V	-7	Lead-Free PQFP	208	Com	20
LFE2-20SE-5FN256C	193	1.2V	-5	Lead-Free fpBGA	256	Com	20
LFE2-20SE-6FN256C	193	1.2V	-6	Lead-Free fpBGA	256	Com	20
LFE2-20SE-7FN256C	193	1.2V	-7	Lead-Free fpBGA	256	Com	20
LFE2-20SE-5FN484C	331	1.2V	-5	Lead-Free fpBGA	484	Com	20
LFE2-20SE-6FN484C	331	1.2V	-6	Lead-Free fpBGA	484	Com	20
LFE2-20SE-7FN484C	331	1.2V	-7	Lead-Free fpBGA	484	Com	20
LFE2-20SE-5FN672C	402	1.2V	-5	Lead-Free fpBGA	672	Com	20
LFE2-20SE-6FN672C	402	1.2V	-6	Lead-Free fpBGA	672	Com	20
LFE2-20SE-7FN672C	402	1.2V	-7	Lead-Free fpBGA	672	Com	20

Part Number	I/Os	Voltage	Grade	Package	Pins	Temp.	LUTs (K)
LFE2-35SE-5FN484C	331	1.2V	-5	Lead-Free fpBGA	484	Com	35
LFE2-35SE-6FN484C	331	1.2V	-6	Lead-Free fpBGA	484	Com	35
LFE2-35SE-7FN484C	331	1.2V	-7	Lead-Free fpBGA	484	Com	35
LFE2-35SE-5FN672C	450	1.2V	-5	Lead-Free fpBGA	672	Com	35
LFE2-35SE-6FN672C	450	1.2V	-6	Lead-Free fpBGA	672	Com	35
LFE2-35SE-7FN672C	450	1.2V	-7	Lead-Free fpBGA	672	Com	35

Part Number	I/Os	Voltage	Grade	Package	Pins	Temp.	LUTs (K)
LFE2-50SE-5FN484C	339	1.2V	-5	Lead-Free fpBGA	484	Com	50
LFE2-50SE-6FN484C	339	1.2V	-6	Lead-Free fpBGA	484	Com	50
LFE2-50SE-7FN484C	339	1.2V	-7	Lead-Free fpBGA	484	Com	50
LFE2-50SE-5FN672C	500	1.2V	-5	Lead-Free fpBGA	672	Com	50
LFE2-50SE-6FN672C	500	1.2V	-6	Lead-Free fpBGA	672	Com	50
LFE2-50SE-7FN672C	500	1.2V	-7	Lead-Free fpBGA	672	Com	50

Part Number	I/Os	Voltage	Grade	Package	Pins	Temp.	LUTs (K)
LFE2-70SE-5FN672C	500	1.2V	-5	Lead-Free fpBGA	672	Com	70
LFE2-70SE-6FN672C	500	1.2V	-6	Lead-Free fpBGA	672	Com	70
LFE2-70SE-7FN672C	500	1.2V	-7	Lead-Free fpBGA	672	Com	70
LFE2-70SE-5FN900C	583	1.2V	-5	Lead-Free fpBGA	900	Com	70
LFE2-70SE-6FN900C	583	1.2V	-6	Lead-Free fpBGA	900	Com	70
LFE2-70SE-7FN900C	583	1.2V	-7	Lead-Free fpBGA	900	Com	70

Industrial

Part Number	I/Os	Voltage	Grade	Package	Pins	Temp.	LUTs (K)
LFE2-6SE-5TN144I	90	1.2V	-5	Lead-Free TQFP	144	Ind	6
LFE2-6SE-6TN144I	90	1.2V	-6	Lead-Free TQFP	144	Ind	6
LFE2-6SE-5FN256I	190	1.2V	-5	Lead-Free fpBGA	256	Ind	6
LFE2-6SE-6FN256I	190	1.2V	-6	Lead-Free fpBGA	256	Ind	6

Part Number	I/Os	Voltage	Grade	Package	Pins	Temp.	LUTs (K)
LFE2-12SE-5TN144I	93	1.2V	-5	Lead-Free TQFP	144	Ind	12
LFE2-12SE-6TN144I	93	1.2V	-6	Lead-Free TQFP	144	Ind	12
LFE2-12SE-5QN208I	131	1.2V	-5	Lead-Free PQFP	208	Ind	12
LFE2-12SE-6QN208I	131	1.2V	-6	Lead-Free PQFP	208	Ind	12
LFE2-12SE-5FN256I	193	1.2V	-5	Lead-Free fpBGA	256	Ind	12
LFE2-12SE-6FN256I	193	1.2V	-6	Lead-Free fpBGA	256	Ind	12
LFE2-12SE-5FN484I	297	1.2V	-5	Lead-Free fpBGA	484	Ind	12
LFE2-12SE-6FN484I	297	1.2V	-6	Lead-Free fpBGA	484	Ind	12

Part Number	I/Os	Voltage	Grade	Package	Pins	Temp.	LUTs (K)
LFE2-20SE-5QN208I	131	1.2V	-5	Lead-Free PQFP	208	Ind	20
LFE2-20SE-6QN208I	131	1.2V	-6	Lead-Free PQFP	208	Ind	20
LFE2-20SE-5FN256I	193	1.2V	-5	Lead-Free fpBGA	256	Ind	20
LFE2-20SE-6FN256I	193	1.2V	-6	Lead-Free fpBGA	256	Ind	20
LFE2-20SE-5FN484I	331	1.2V	-5	Lead-Free fpBGA	484	Ind	20
LFE2-20SE-6FN484I	331	1.2V	-6	Lead-Free fpBGA	484	Ind	20
LFE2-20SE-5FN672I	402	1.2V	-5	Lead-Free fpBGA	672	Ind	20
LFE2-20SE-6FN672I	402	1.2V	-6	Lead-Free fpBGA	672	Ind	20

Part Number	I/Os	Voltage	Grade	Package	Pins	Temp.	LUTs (K)
LFE2-35SE-5FN484I	331	1.2V	-5	Lead-Free fpBGA	484	Ind	35
LFE2-35SE-6FN484I	331	1.2V	-6	Lead-Free fpBGA	484	Ind	35
LFE2-35SE-5FN672I	450	1.2V	-5	Lead-Free fpBGA	672	Ind	35
LFE2-35SE-6FN672I	450	1.2V	-6	Lead-Free fpBGA	672	Ind	35

Part Number	I/Os	Voltage	Grade	Package	Pins	Temp.	LUTs (K)
LFE2-50SE-5FN484I	339	1.2V	-5	Lead-Free fpBGA	484	Ind	50
LFE2-50SE-6FN484I	339	1.2V	-6	Lead-Free fpBGA	484	Ind	50
LFE2-50SE-5FN672I	500	1.2V	-5	Lead-Free fpBGA	672	Ind	50
LFE2-50SE-6FN672I	500	1.2V	-6	Lead-Free fpBGA	672	Ind	50

Part Number	I/Os	Voltage	Grade	Package	Pins	Temp.	LUTs (K)
LFE2-70SE-5FN672I	500	1.2V	-5	Lead-Free fpBGA	672	Ind	70
LFE2-70SE-6FN672I	500	1.2V	-6	Lead-Free fpBGA	672	Ind	70
LFE2-70SE-5FN900I	583	1.2V	-5	Lead-Free fpBGA	900	Ind	70
LFE2-70SE-6FN900I	583	1.2V	-6	Lead-Free fpBGA	900	Ind	70

LatticeECP2M Part Number Description

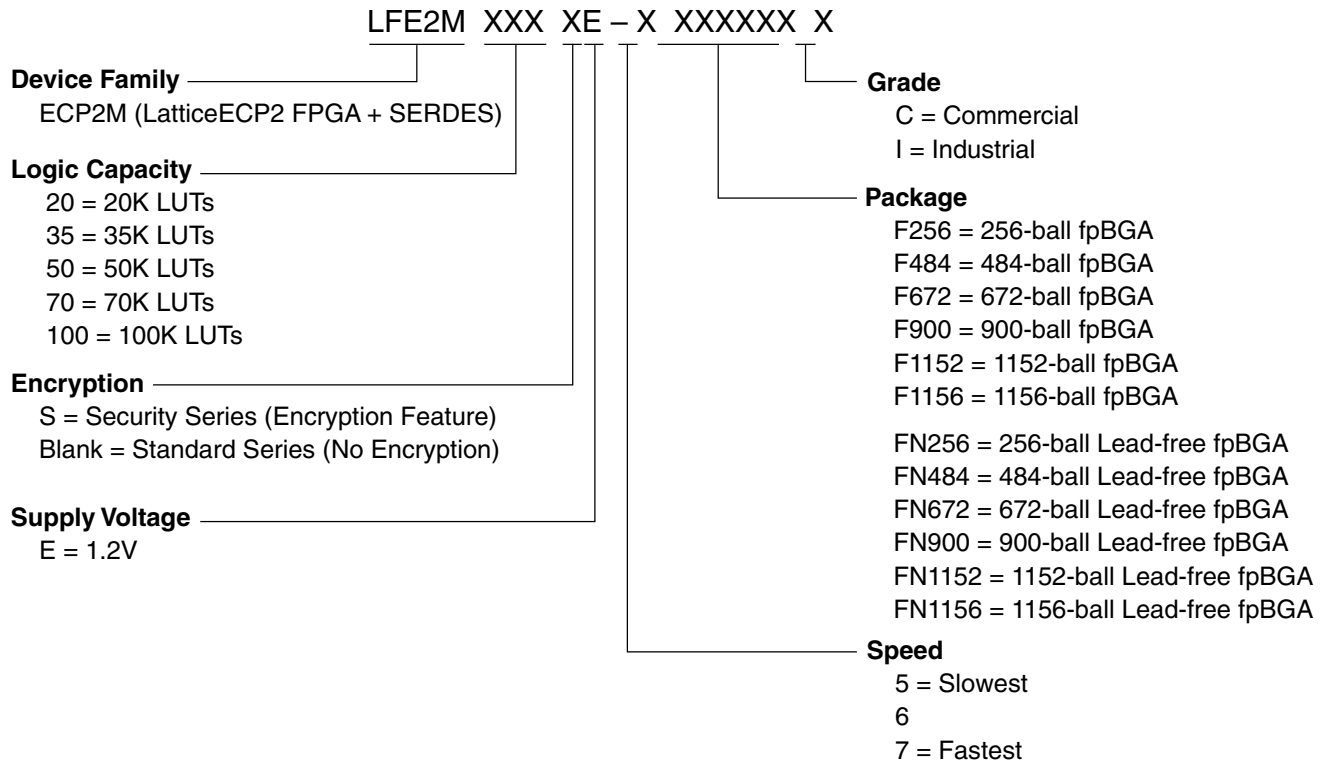

Ordering Information

Note: LatticeECP2M devices are dual marked. For example, the commercial speed grade LFE2M50E-7F672C is also marked with industrial grade -6I (LFE2M50E-6F672I). The commercial grade is one speed grade faster than the associated dual mark industrial grade. The slowest commercial grade does not have industrial markings. The markings appear as follows:

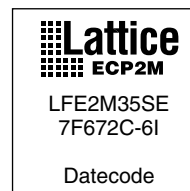
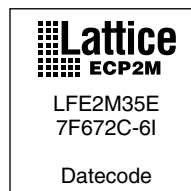

Contact Your Local Lattice Sales Representative for Product Availability.

LatticeECP2M Standard Series Devices, Conventional Packaging**Commercial**

Part Number	I/Os	Voltage	Grade	Package	Pins	Temp.	LUTs (K)
LFE2M20E-5F484C	304	1.2V	-5	fpBGA	484	COM	20
LFE2M20E-6F484C	304	1.2V	-6	fpBGA	484	COM	20
LFE2M20E-7F484C	304	1.2V	-7	fpBGA	484	COM	20
LFE2M20E-5F256C	140	1.2V	-5	fpBGA	256	COM	20
LFE2M20E-6F256C	140	1.2V	-6	fpBGA	256	COM	20
LFE2M20E-7F256C	140	1.2V	-7	fpBGA	256	COM	20

Part Number	I/Os	Voltage	Grade	Package	Pins	Temp.	LUTs (K)
LFE2M35E-5F672C	410	1.2V	-5	fpBGA	672	COM	35
LFE2M35E-6F672C	410	1.2V	-6	fpBGA	672	COM	35
LFE2M35E-7F672C	410	1.2V	-7	fpBGA	672	COM	35
LFE2M35E-5F484C	303	1.2V	-5	fpBGA	484	COM	35
LFE2M35E-6F484C	303	1.2V	-6	fpBGA	484	COM	35
LFE2M35E-7F484C	303	1.2V	-7	fpBGA	484	COM	35
LFE2M35E-5F256C	140	1.2V	-5	fpBGA	256	COM	35
LFE2M35E-6F256C	140	1.2V	-6	fpBGA	256	COM	35
LFE2M35E-7F256C	140	1.2V	-7	fpBGA	256	COM	35

Part Number	I/Os	Voltage	Grade	Package	Pins	Temp.	LUTs (K)
LFE2M50E-5F900C	410	1.2V	-5	fpBGA	900	COM	50
LFE2M50E-6F900C	410	1.2V	-6	fpBGA	900	COM	50
LFE2M50E-7F900C	410	1.2V	-7	fpBGA	900	COM	50
LFE2M50E-5F672C	372	1.2V	-5	fpBGA	672	COM	50
LFE2M50E-6F672C	372	1.2V	-6	fpBGA	672	COM	50
LFE2M50E-7F672C	372	1.2V	-7	fpBGA	672	COM	50
LFE2M50E-5F484C	270	1.2V	-5	fpBGA	484	COM	50
LFE2M50E-6F484C	270	1.2V	-6	fpBGA	484	COM	50
LFE2M50E-7F484C	270	1.2V	-7	fpBGA	484	COM	50

Part Number	I/Os	Voltage	Grade	Package	Pins	Temp.	LUTs (K)
LFE2M70E-5F1152C	436	1.2V	-5	fpBGA	1152	COM	70
LFE2M70E-6F1152C	436	1.2V	-6	fpBGA	1152	COM	70
LFE2M70E-7F1152C	436	1.2V	-7	fpBGA	1152	COM	70
LFE2M70E-5F900C	416	1.2V	-5	fpBGA	900	COM	70
LFE2M70E-6F900C	416	1.2V	-6	fpBGA	900	COM	70
LFE2M70E-7F900C	416	1.2V	-7	fpBGA	900	COM	70

Part Number	I/Os	Voltage	Grade	Package	Pins	Temp.	LUTs (K)
LFE2M100E-5F1152C	520	1.2V	-5	fpBGA	1152	COM	100
LFE2M100E-6F1152C	520	1.2V	-6	fpBGA	1152	COM	100
LFE2M100E-7F1152C	520	1.2V	-7	fpBGA	1152	COM	100
LFE2M100E-5F900C	416	1.2V	-5	fpBGA	900	COM	100
LFE2M100E-6F900C	416	1.2V	-6	fpBGA	900	COM	100
LFE2M100E-7F900C	416	1.2V	-7	fpBGA	900	COM	100

Industrial

Part Number	I/Os	Voltage	Grade	Package	Pins	Temp.	LUTs (K)
LFE2M20E-5F484I	304	1.2V	-5	fpBGA	484	IND	20
LFE2M20E-6F484I	304	1.2V	-6	fpBGA	484	IND	20
LFE2M20E-5F256I	140	1.2V	-5	fpBGA	256	IND	20
LFE2M20E-6F256I	140	1.2V	-6	fpBGA	256	IND	20

Part Number	I/Os	Voltage	Grade	Package	Pins	Temp.	LUTs (K)
LFE2M35E-5F672I	410	1.2V	-5	fpBGA	672	IND	35
LFE2M35E-6F672I	410	1.2V	-6	fpBGA	672	IND	35
LFE2M35E-5F484I	303	1.2V	-5	fpBGA	484	IND	35
LFE2M35E-6F484I	303	1.2V	-6	fpBGA	484	IND	35
LFE2M35E-5F256I	140	1.2V	-5	fpBGA	256	IND	35
LFE2M35E-6F256I	140	1.2V	-6	fpBGA	256	IND	35

Part Number	I/Os	Voltage	Grade	Package	Pins	Temp.	LUTs (K)
LFE2M50E-5F900I	410	1.2V	-5	fpBGA	900	IND	50
LFE2M50E-6F900I	410	1.2V	-6	fpBGA	900	IND	50
LFE2M50E-5F672I	372	1.2V	-5	fpBGA	672	IND	50
LFE2M50E-6F672I	372	1.2V	-6	fpBGA	672	IND	50
LFE2M50E-5F484I	270	1.2V	-5	fpBGA	484	IND	50
LFE2M50E-6F484I	270	1.2V	-6	fpBGA	484	IND	50

Part Number	I/Os	Voltage	Grade	Package	Pins	Temp.	LUTs (K)
LFE2M70E-5F1152I	436	1.2V	-5	fpBGA	1152	IND	70
LFE2M70E-6F1152I	436	1.2V	-6	fpBGA	1152	IND	70
LFE2M70E-5F900I	416	1.2V	-5	fpBGA	900	IND	70
LFE2M70E-6F900I	416	1.2V	-6	fpBGA	900	IND	70

Part Number	I/Os	Voltage	Grade	Package	Pins	Temp.	LUTs (K)
LFE2M100E-5F1152I	520	1.2V	-5	fpBGA	1152	IND	100
LFE2M100E-6F1152I	520	1.2V	-6	fpBGA	1152	IND	100
LFE2M100E-5F900I	416	1.2V	-5	fpBGA	900	IND	100
LFE2M100E-6F900I	416	1.2V	-6	fpBGA	900	IND	100

LatticeECP2M Standard Series Devices, Lead-Free Packaging**Commercial**

Part Number	I/Os	Voltage	Grade	Package	Pins	Temp.	LUTs (K)
LFE2M20E-5FN484C	304	1.2V	-5	Lead-Free fpBGA	484	COM	20
LFE2M20E-6FN484C	304	1.2V	-6	Lead-Free fpBGA	484	COM	20
LFE2M20E-7FN484C	304	1.2V	-7	Lead-Free fpBGA	484	COM	20
LFE2M20E-5FN256C	140	1.2V	-5	Lead-Free fpBGA	256	COM	20
LFE2M20E-6FN256C	140	1.2V	-6	Lead-Free fpBGA	256	COM	20
LFE2M20E-7FN256C	140	1.2V	-7	Lead-Free fpBGA	256	COM	20

Part Number	I/Os	Voltage	Grade	Package	Pins	Temp.	LUTs (K)
LFE2M35E-5FN672C	410	1.2V	-5	Lead-Free fpBGA	672	COM	35
LFE2M35E-6FN672C	410	1.2V	-6	Lead-Free fpBGA	672	COM	35
LFE2M35E-7FN672C	410	1.2V	-7	Lead-Free fpBGA	672	COM	35
LFE2M35E-5FN484C	303	1.2V	-5	Lead-Free fpBGA	484	COM	35
LFE2M35E-6FN484C	303	1.2V	-6	Lead-Free fpBGA	484	COM	35
LFE2M35E-7FN484C	303	1.2V	-7	Lead-Free fpBGA	484	COM	35
LFE2M35E-5FN256C	140	1.2V	-5	Lead-Free fpBGA	256	COM	35
LFE2M35E-6FN256C	140	1.2V	-6	Lead-Free fpBGA	256	COM	35
LFE2M35E-7FN256C	140	1.2V	-7	Lead-Free fpBGA	256	COM	35

Part Number	I/Os	Voltage	Grade	Package	Pins	Temp.	LUTs (K)
LFE2M50E-5FN900C	410	1.2V	-5	Lead-Free fpBGA	900	COM	50
LFE2M50E-6FN900C	410	1.2V	-6	Lead-Free fpBGA	900	COM	50
LFE2M50E-7FN900C	410	1.2V	-7	Lead-Free fpBGA	900	COM	50
LFE2M50E-5FN672C	372	1.2V	-5	Lead-Free fpBGA	672	COM	50
LFE2M50E-6FN672C	372	1.2V	-6	Lead-Free fpBGA	672	COM	50
LFE2M50E-7FN672C	372	1.2V	-7	Lead-Free fpBGA	672	COM	50
LFE2M50E-5FN484C	270	1.2V	-5	Lead-Free fpBGA	484	COM	50
LFE2M50E-6FN484C	270	1.2V	-6	Lead-Free fpBGA	484	COM	50
LFE2M50E-7FN484C	270	1.2V	-7	Lead-Free fpBGA	484	COM	50

Part Number	I/Os	Voltage	Grade	Package	Pins	Temp.	LUTs (K)
LFE2M70E-5FN1152C	436	1.2V	-5	Lead-Free fpBGA	1152	COM	70
LFE2M70E-6FN1152C	436	1.2V	-6	Lead-Free fpBGA	1152	COM	70
LFE2M70E-7FN1152C	436	1.2V	-7	Lead-Free fpBGA	1152	COM	70
LFE2M70E-5FN900C	416	1.2V	-5	Lead-Free fpBGA	900	COM	70
LFE2M70E-6FN900C	416	1.2V	-6	Lead-Free fpBGA	900	COM	70
LFE2M70E-7FN900C	416	1.2V	-7	Lead-Free fpBGA	900	COM	70

Part Number	I/Os	Voltage	Grade	Package	Pins	Temp.	LUTs (K)
LFE2M100E-5FN1152C	520	1.2V	-5	Lead-Free fpBGA	1152	COM	100
LFE2M100E-6FN1152C	520	1.2V	-6	Lead-Free fpBGA	1152	COM	100
LFE2M100E-7FN1152C	520	1.2V	-7	Lead-Free fpBGA	1152	COM	100
LFE2M100E-5FN900C	416	1.2V	-5	Lead-Free fpBGA	900	COM	100
LFE2M100E-6FN900C	416	1.2V	-6	Lead-Free fpBGA	900	COM	100
LFE2M100E-7FN900C	416	1.2V	-7	Lead-Free fpBGA	900	COM	100

Industrial

Part Number	I/Os	Voltage	Grade	Package	Pins	Temp.	LUTs (K)
LFE2M20E-5FN484I	304	1.2V	-5	Lead-Free fpBGA	484	IND	20
LFE2M20E-6FN484I	304	1.2V	-6	Lead-Free fpBGA	484	IND	20
LFE2M20E-5FN256I	140	1.2V	-5	Lead-Free fpBGA	256	IND	20
LFE2M20E-6FN256I	140	1.2V	-6	Lead-Free fpBGA	256	IND	20

Part Number	I/Os	Voltage	Grade	Package	Pins	Temp.	LUTs (K)
LFE2M35E-5FN672I	410	1.2V	-5	Lead-Free fpBGA	672	IND	35
LFE2M35E-6FN672I	410	1.2V	-6	Lead-Free fpBGA	672	IND	35
LFE2M35E-5FN484I	303	1.2V	-5	Lead-Free fpBGA	484	IND	35
LFE2M35E-6FN484I	303	1.2V	-6	Lead-Free fpBGA	484	IND	35
LFE2M35E-5FN256I	140	1.2V	-5	Lead-Free fpBGA	256	IND	35
LFE2M35E-6FN256I	140	1.2V	-6	Lead-Free fpBGA	256	IND	35

Part Number	I/Os	Voltage	Grade	Package	Pins	Temp.	LUTs (K)
LFE2M50E-5FN900I	410	1.2V	-5	Lead-Free fpBGA	900	Ind	50
LFE2M50E-6FN900I	410	1.2V	-6	Lead-Free fpBGA	900	Ind	50
LFE2M50E-5FN672I	372	1.2V	-5	Lead-Free fpBGA	672	Ind	50
LFE2M50E-6FN672I	372	1.2V	-6	Lead-Free fpBGA	672	Ind	50
LFE2M50E-5FN484I	270	1.2V	-5	Lead-Free fpBGA	484	Ind	50
LFE2M50E-6FN484I	270	1.2V	-6	Lead-Free fpBGA	484	Ind	50

Part Number	I/Os	Voltage	Grade	Package	Pins	Temp.	LUTs (K)
LFE2M70E-5FN1152I	436	1.2V	-5	Lead-Free fpBGA	1152	Ind	70
LFE2M70E-6FN1152I	436	1.2V	-6	Lead-Free fpBGA	1152	Ind	70
LFE2M70E-5FN900I	416	1.2V	-5	Lead-Free fpBGA	900	Ind	70
LFE2M70E-6FN900I	416	1.2V	-6	Lead-Free fpBGA	900	Ind	70

Part Number	I/Os	Voltage	Grade	Package	Pins	Temp.	LUTs (K)
LFE2M100E-5FN1152I	520	1.2V	-5	Lead-Free fpBGA	1152	Ind	100
LFE2M100E-6FN1152I	520	1.2V	-6	Lead-Free fpBGA	1152	Ind	100
LFE2M100E-5FN900I	416	1.2V	-5	Lead-Free fpBGA	900	Ind	100
LFE2M100E-6FN900I	416	1.2V	-6	Lead-Free fpBGA	900	Ind	100

LatticeECP2M S-Series Devices, Conventional Packaging

Commercial

Part Number	I/Os	Voltage	Grade	Package	Pins	Temp.	LUTs (K)
LFE2M20SE-5F484C	304	1.2V	-5	fpBGA	484	Com	20
LFE2M20SE-6F484C	304	1.2V	-6	fpBGA	484	Com	20
LFE2M20SE-7F484C	304	1.2V	-7	fpBGA	484	Com	20
LFE2M20SE-5F256C	140	1.2V	-5	fpBGA	256	Com	20
LFE2M20SE-6F256C	140	1.2V	-6	fpBGA	256	Com	20
LFE2M20SE-7F256C	140	1.2V	-7	fpBGA	256	Com	20

Part Number	I/Os	Voltage	Grade	Package	Pins	Temp.	LUTs (K)
LFE2M35SE-5F672C	410	1.2V	-5	fpBGA	672	Com	35
LFE2M35SE-6F672C	410	1.2V	-6	fpBGA	672	Com	35
LFE2M35SE-7F672C	410	1.2V	-7	fpBGA	672	Com	35
LFE2M35SE-5F484C	303	1.2V	-5	fpBGA	484	Com	35
LFE2M35SE-6F484C	303	1.2V	-6	fpBGA	484	Com	35
LFE2M35SE-7F484C	303	1.2V	-7	fpBGA	484	Com	35
LFE2M35SE-5F256C	140	1.2V	-5	fpBGA	256	Com	35
LFE2M35SE-6F256C	140	1.2V	-6	fpBGA	256	Com	35
LFE2M35SE-7F256C	140	1.2V	-7	fpBGA	256	Com	35

Part Number	I/Os	Voltage	Grade	Package	Pins	Temp.	LUTs (K)
LFE2M50SE-5F900C	410	1.2V	-5	fpBGA	900	Com	50
LFE2M50SE-6F900C	410	1.2V	-6	fpBGA	900	Com	50
LFE2M50SE-7F900C	410	1.2V	-7	fpBGA	900	Com	50
LFE2M50SE-5F672C	372	1.2V	-5	fpBGA	672	Com	50
LFE2M50SE-6F672C	372	1.2V	-6	fpBGA	672	Com	50
LFE2M50SE-7F672C	372	1.2V	-7	fpBGA	672	Com	50
LFE2M50SE-5F484C	270	1.2V	-5	fpBGA	484	Com	50
LFE2M50SE-6F484C	270	1.2V	-6	fpBGA	484	Com	50
LFE2M50SE-7F484C	270	1.2V	-7	fpBGA	484	Com	50

Part Number	I/Os	Voltage	Grade	Package	Pins	Temp.	LUTs (K)
LFE2M70SE-5F1152C	436	1.2V	-5	fpBGA	1152	Com	70
LFE2M70SE-6F1152C	436	1.2V	-6	fpBGA	1152	Com	70
LFE2M70SE-7F1152C	436	1.2V	-7	fpBGA	1152	Com	70
LFE2M70SE-5F900C	416	1.2V	-5	fpBGA	900	Com	70
LFE2M70SE-6F900C	416	1.2V	-6	fpBGA	900	Com	70
LFE2M70SE-7F900C	416	1.2V	-7	fpBGA	900	Com	70

Part Number	I/Os	Voltage	Grade	Package	Pins	Temp.	LUTs (K)
LFE2M100SE-5F1152C	520	1.2V	-5	fpBGA	1152	Com	100
LFE2M100SE-6F1152C	520	1.2V	-6	fpBGA	1152	Com	100
LFE2M100SE-7F1152C	520	1.2V	-7	fpBGA	1152	Com	100
LFE2M100SE-5F900C	416	1.2V	-5	fpBGA	900	Com	100
LFE2M100SE-6F900C	416	1.2V	-6	fpBGA	900	Com	100
LFE2M100SE-7F900C	416	1.2V	-7	fpBGA	900	Com	100

Industrial

Part Number	I/Os	Voltage	Grade	Package	Pins	Temp.	LUTs (K)
LFE2M20SE-5F484I	304	1.2V	-5	fpBGA	484	Ind	20
LFE2M20SE-6F484I	304	1.2V	-6	fpBGA	484	Ind	20
LFE2M20SE-5F256I	140	1.2V	-5	fpBGA	256	Ind	20
LFE2M20SE-6F256I	140	1.2V	-6	fpBGA	256	Ind	20

Part Number	I/Os	Voltage	Grade	Package	Pins	Temp.	LUTs (K)
LFE2M35SE-5F672I	410	1.2V	-5	fpBGA	672	Ind	35
LFE2M35SE-6F672I	410	1.2V	-6	fpBGA	672	Ind	35
LFE2M35SE-5F484I	303	1.2V	-5	fpBGA	484	Ind	35
LFE2M35SE-6F484I	303	1.2V	-6	fpBGA	484	Ind	35
LFE2M35SE-5F256I	140	1.2V	-5	fpBGA	256	Ind	35
LFE2M35SE-6F256I	140	1.2V	-6	fpBGA	256	Ind	35

Part Number	I/Os	Voltage	Grade	Package	Pins	Temp.	LUTs (K)
LFE2M50SE-5F900I	410	1.2V	-5	fpBGA	900	Ind	50
LFE2M50SE-6F900I	410	1.2V	-6	fpBGA	900	Ind	50
LFE2M50SE-5F672I	372	1.2V	-5	fpBGA	672	Ind	50
LFE2M50SE-6F672I	372	1.2V	-6	fpBGA	672	Ind	50
LFE2M50SE-5F484I	270	1.2V	-5	fpBGA	484	Ind	50
LFE2M50SE-6F484I	270	1.2V	-6	fpBGA	484	Ind	50

Part Number	I/Os	Voltage	Grade	Package	Pins	Temp.	LUTs (K)
LFE2M70SE-5F1152I	436	1.2V	-5	fpBGA	1152	Ind	70
LFE2M70SE-6F1152I	436	1.2V	-6	fpBGA	1152	Ind	70
LFE2M70SE-5F900I	416	1.2V	-5	fpBGA	900	Ind	70
LFE2M70SE-6F900I	416	1.2V	-6	fpBGA	900	Ind	70

Part Number	I/Os	Voltage	Grade	Package	Pins	Temp.	LUTs (K)
LFE2M100SE-5F1152I	520	1.2V	-5	fpBGA	1152	Ind	100
LFE2M100SE-6F1152I	520	1.2V	-6	fpBGA	1152	Ind	100
LFE2M100SE-5F900I	416	1.2V	-5	fpBGA	900	Ind	100
LFE2M100SE-6F900I	416	1.2V	-6	fpBGA	900	Ind	100

LatticeECP2M S-Series Devices, Lead-Free Packaging**Commercial**

Part Number	I/Os	Voltage	Grade	Package	Pins	Temp.	LUTs (K)
LFE2M20SE-5FN484C	304	1.2V	-5	Lead-Free fpBGA	484	Com	20
LFE2M20SE-6FN484C	304	1.2V	-6	Lead-Free fpBGA	484	Com	20
LFE2M20SE-7FN484C	304	1.2V	-7	Lead-Free fpBGA	484	Com	20
LFE2M20SE-5FN256C	140	1.2V	-5	Lead-Free fpBGA	256	Com	20
LFE2M20SE-6FN256C	140	1.2V	-6	Lead-Free fpBGA	256	Com	20
LFE2M20SE-7FN256C	140	1.2V	-7	Lead-Free fpBGA	256	Com	20

Part Number	I/Os	Voltage	Grade	Package	Pins	Temp.	LUTs (K)
LFE2M35SE-5FN672C	410	1.2V	-5	Lead-Free fpBGA	672	Com	35
LFE2M35SE-6FN672C	410	1.2V	-6	Lead-Free fpBGA	672	Com	35
LFE2M35SE-7FN672C	410	1.2V	-7	Lead-Free fpBGA	672	Com	35
LFE2M35SE-5FN484C	303	1.2V	-5	Lead-Free fpBGA	484	Com	35
LFE2M35SE-6FN484C	303	1.2V	-6	Lead-Free fpBGA	484	Com	35
LFE2M35SE-7FN484C	303	1.2V	-7	Lead-Free fpBGA	484	Com	35
LFE2M35SE-5FN256C	140	1.2V	-5	Lead-Free fpBGA	256	Com	35
LFE2M35SE-6FN256C	140	1.2V	-6	Lead-Free fpBGA	256	Com	35
LFE2M35SE-7FN256C	140	1.2V	-7	Lead-Free fpBGA	256	Com	35

Part Number	I/Os	Voltage	Grade	Package	Pins	Temp.	LUTs (K)
LFE2M50SE-5FN900C	410	1.2V	-5	Lead-Free fpBGA	900	Com	50
LFE2M50SE-6FN900C	410	1.2V	-6	Lead-Free fpBGA	900	Com	50
LFE2M50SE-7FN900C	410	1.2V	-7	Lead-Free fpBGA	900	Com	50
LFE2M50SE-5FN672C	372	1.2V	-5	Lead-Free fpBGA	672	Com	50
LFE2M50SE-6FN672C	372	1.2V	-6	Lead-Free fpBGA	672	Com	50
LFE2M50SE-7FN672C	372	1.2V	-7	Lead-Free fpBGA	672	Com	50
LFE2M50SE-5FN484C	270	1.2V	-5	Lead-Free fpBGA	484	Com	50
LFE2M50SE-6FN484C	270	1.2V	-6	Lead-Free fpBGA	484	Com	50
LFE2M50SE-7FN484C	270	1.2V	-7	Lead-Free fpBGA	484	Com	50

Part Number	I/Os	Voltage	Grade	Package	Pins	Temp.	LUTs (K)
LFE2M70SE-5FN1152C	436	1.2V	-5	Lead-Free fpBGA	1152	Com	70
LFE2M70SE-6FN1152C	436	1.2V	-6	Lead-Free fpBGA	1152	Com	70
LFE2M70SE-7FN1152C	436	1.2V	-7	Lead-Free fpBGA	1152	Com	70
LFE2M70SE-5FN900C	416	1.2V	-5	Lead-Free fpBGA	900	Com	70
LFE2M70SE-6FN900C	416	1.2V	-6	Lead-Free fpBGA	900	Com	70
LFE2M70SE-7FN900C	416	1.2V	-7	Lead-Free fpBGA	900	Com	70

Part Number	I/Os	Voltage	Grade	Package	Pins	Temp.	LUTs (K)
LFE2M100SE-5FN1152C	520	1.2V	-5	Lead-Free fpBGA	1152	Com	100
LFE2M100SE-6FN1152C	520	1.2V	-6	Lead-Free fpBGA	1152	Com	100
LFE2M100SE-7FN1152C	520	1.2V	-7	Lead-Free fpBGA	1152	Com	100
LFE2M100SE-5FN900C	416	1.2V	-5	Lead-Free fpBGA	900	Com	100
LFE2M100SE-6FN900C	416	1.2V	-6	Lead-Free fpBGA	900	Com	100
LFE2M100SE-7FN900C	416	1.2V	-7	Lead-Free fpBGA	900	Com	100

Industrial

Part Number	I/Os	Voltage	Grade	Package	Pins	Temp.	LUTs (K)
LFE2M20SE-5FN484I	304	1.2V	-5	Lead-Free fpBGA	484	Ind	20
LFE2M20SE-6FN484I	304	1.2V	-6	Lead-Free fpBGA	484	Ind	20
LFE2M20SE-5FN256I	140	1.2V	-5	Lead-Free fpBGA	256	Ind	20
LFE2M20SE-6FN256I	140	1.2V	-6	Lead-Free fpBGA	256	Ind	20

Part Number	I/Os	Voltage	Grade	Package	Pins	Temp.	LUTs (K)
LFE2M35SE-5FN672I	410	1.2V	-5	Lead-Free fpBGA	672	Ind	35
LFE2M35SE-6FN672I	410	1.2V	-6	Lead-Free fpBGA	672	Ind	35
LFE2M35SE-5FN484I	303	1.2V	-5	Lead-Free fpBGA	484	Ind	35
LFE2M35SE-6FN484I	303	1.2V	-6	Lead-Free fpBGA	484	Ind	35
LFE2M35SE-5FN256I	140	1.2V	-5	Lead-Free fpBGA	256	Ind	35
LFE2M35SE-6FN256I	140	1.2V	-6	Lead-Free fpBGA	256	Ind	35

Part Number	I/Os	Voltage	Grade	Package	Pins	Temp.	LUTs (K)
LFE2M50SE-5FN900I	410	1.2V	-5	Lead-Free fpBGA	900	Ind	50
LFE2M50SE-6FN900I	410	1.2V	-6	Lead-Free fpBGA	900	Ind	50
LFE2M50SE-5FN672I	372	1.2V	-5	Lead-Free fpBGA	672	Ind	50
LFE2M50SE-6FN672I	372	1.2V	-6	Lead-Free fpBGA	672	Ind	50
LFE2M50SE-5FN484I	270	1.2V	-5	Lead-Free fpBGA	484	Ind	50
LFE2M50SE-6FN484I	270	1.2V	-6	Lead-Free fpBGA	484	Ind	50

Part Number	I/Os	Voltage	Grade	Package	Pins	Temp.	LUTs (K)
LFE2M70SE-5FN1152I	436	1.2V	-5	Lead-Free fpBGA	1152	Ind	70
LFE2M70SE-6FN1152I	436	1.2V	-6	Lead-Free fpBGA	1152	Ind	70
LFE2M70SE-5FN900I	416	1.2V	-5	Lead-Free fpBGA	900	Ind	70
LFE2M70SE-6FN900I	416	1.2V	-6	Lead-Free fpBGA	900	Ind	70

Part Number	I/Os	Voltage	Grade	Package	Pins	Temp.	LUTs (K)
LFE2M100SE-5FN1152I	520	1.2V	-5	Lead-Free fpBGA	1152	Ind	100
LFE2M100SE-6FN1152I	520	1.2V	-6	Lead-Free fpBGA	1152	Ind	100
LFE2M100SE-5FN900I	416	1.2V	-5	Lead-Free fpBGA	900	Ind	100
LFE2M100SE-6FN900I	416	1.2V	-6	Lead-Free fpBGA	900	Ind	100

For Further Information

A variety of technical notes for the LatticeECP2 family are available on the Lattice web site at www.latticesemi.com.

- LatticeECP2M SERDES/PCS Usage Guide (TN1124)
- LatticeECP2/M sysIO Usage Guide (TN1102)
- LatticeECP2/M sysCLOCK PLL Design and Usage Guide (TN1103)
- LatticeECP2/M Memory Usage Guide (TN1104)
- LatticeECP2/M High-Speed I/O Interface (TN1105)
- Power Estimation and Management for LatticeECP2/M Devices (TN1106)
- LatticeECP2/M sysDSP Usage Guide (TN1107)
- LatticeECP2/M sysCONFIG Usage Guide (TN1108)
- LatticeECP2/M Configuration Encryption Usage Guide (TN1109)
- LatticeECP2/M Soft Error Detection (SED) Usage Guide (TN1113)

For further information about interface standards refer to the following web sites:

- JEDEC Standards (LVTTTL, LVCMOS, SSTL, HSTL): www.jedec.org
- PCI: www.pcisig.com

Date	Version	Section	Change Summary
February 2006	01.0	—	Initial release.
August 2006	01.1	Introduction	Updated Table 1-1 “LatticeECP2 Family Selection Guide”
		Architecture	Updated figure 2-2 “PFU Diagram”
			Updated figure 2-13 “Secondary Clock Regions ECP2-50”
			Updated figure 2-25 “PIC Diagram”
			Updated figure 2-26 “Input Register Block for Left, Right and Bottom Edges”
			Updated figure 2-28 “Output Register Block for Left, Right and Bottom Edges”
			Updated figure 2-30 “DQS Input Routing for Left and Right Edges”
			Updated figure 2-32 “Edge Clock, DLL Calibration and DQS Local Bus Distribution”
			Table 2-15 Selectable Master clock (CCLK) frequencies Removed frequencies 15,20,21,22,23,30,34,41,45,51,55,60
			Replaced “CLKINDEL” with “CLKO”
			Updated SED section
			Qualified device migration capability when using DQS banks for DDR interfaces
		DC and Switching Characteristics	Added VCCPLL to the Recommended Operating Conditions Table
			Remove Note 5 from “Hot Specifications” section
			Added note 7 & 8 to “Initialization Supply current Table
			Change Note 6 - “...down to 95MHz” to “...down to 95MHz for DDR and 133MHz for DDR2”
			New “Typical Building Block Function Performance” numbers
			New External Switching Characteristics numbers
			New Internal Switching Characteristics numbers
			New Family Timing Adders numbers
			Updated Timings for GPLLs, SPLLs and DLLs
			Added sysConfig waveforms.
			Remove HSTL15D_II from sysIO Recommended Operating Condition Table
		Pinout Information	Updated Supply and initialization currents for ECP2-50
			Added VCCPLL to the Signal Descriptions Table
			Updated Logic signal Connections tables to include 484-fpBGA for the ECP2-50.
			Added Logic signal Connections tables for ECP2-12 devices.
Updated Pin Information Summary table to include ECP2-12.			
Updated Power Supply and NC Connections table to include ECP2-12.			
Added Note 2 to DDR Strobe (DQS) Pin Table			
Added Information on: PCI, DDR & SPI4.2 Capabilities of the device-Package combination			

Date	Version	Section	Change Summary
August 2006 (cont.)	01.1 (cont.)	Pinout Information (cont.)	Added Information on: Available Device Resources per Packaged Device table
		Ordering Information	Updated ordering part number table to include ECP2-12. Updated topside mark drawing
September 2006	02.0	Multiple	Added information regarding LatticeECP2M support throughout.
September 2006	02.1	DC and Switching Characteristics	Added Receiver Total Jitter Tolerance Specification table.
			Removed power-up requirements for proper configuration footnote in Recommended Operating Conditions table.
December 2006	02.2	Introduction	LatticeECP2M Selection Guide table has been updated.
		Architecture	Figure 2-16. Per Region Secondary Clock Selection has been updated.
			Figure 2-39. Simplified Channel Block Diagram for SERDES and PCS has been updated.
		DC and Switching	Footnotes have been added to Recommended Operating Conditions
			DC Electrical Characteristics table has been updated.
			Supply Current (Standby) tables have been updated.
			Initialization Supply Current table have been updated.
	Updated timing numbers to include LFE2-12E (rev A 0.08)		
Pinout Information	Updated to include the entire ECP2 device information as well as 256-fpBGA and 484-fpBGA pin information for the ECP2M35E.		
Ordering Information	Updated to include the entire ECP2 and ECP2M device ordering information.		
February 2007	02.3	Architecture	Updated EBR Asynchronous Reset section.
March 2007	02.4	DC and Switching Characteristics	Power-sequencing footnotes have been added to the Recommended Operating Conditions. DDR2 performance has been updated to 266MHz.
March 2007	02.5	Introduction	Added "Security Series" to the LatticeECP2 and LatticeECP2M families.
		Architecture	Enhanced Configuration Option section updated.
		DC and Switching	Recommended Operating Conditions table - footnote 4 updated.
		Ordering Information	"Security Series" ordering part numbers added.
April 2007	02.6	Introduction	LatticeECP2M family table has been updated for user I/O counts.
		Ordering Information	LatticeECP2M family ordering part number section has been updated to add 1152-fpBGA package for the ECP2M70 and ECP2M100.
July 2007	02.7	Architecture	Updated text in Ripple Mode section.
		DC and Switching	ECP2/M Supply Current information has been updated. Typical Building Block Function Performance, External Switching Characteristics, Internal Switching Characteristics, Family Timing Adders, sysCLOCK GPLL Timing, sysCLOCK SPLL Timing, DLL Timing and sysCONFIG Port Timing Specifications have been updated (timing rev. A 0.10). SERDES timing information has been updated. PCI Express timing information has been updated.
		Pinout Information	Added LatticeECP2M20 pinout information.
August 2007	02.8	Introduction	1156-fpBGA package option has been removed from the LatticeECP2M family.
		Architecture	Table 2-16. Selectable Master Clock (CCLK) Frequencies During Configuration table has been updated.
		DC and Switching	Supply Current (Standby) table has been updated.
DSP Function timing has been updated.			

Date	Version	Section	Change Summary
August 2007 (cont.)	02.8 (cont.)	DC and Switching (cont.)	sysCLOCK GPLL timing has been updated.
		Pinout Information	Added ECP2M50 (484/672/900-fpBGA), ECP2M70 (900-fpBGA) and ECP2M100 (900-fpBGA) pinout information.
		Ordering Information	1156-fpBGA package option has been removed from the LatticeECP2M family.
September 2007	02.9	Pinout Information	Added Thermal Management text section.
February 2008	03.0	Architecture	Added LVC MOS33D description.
		DC and Switching	LatticeECP2M Supply Current has been updated.
			Typical Building Block Function Performance, External Switching Characteristics, Internal Switching Characteristics, Family Timing Adders, sysCLOCK GPLL Timing, sysCLOCK SPLL Timing, DLL Timing and sysCONFIG Port Timing Specifications have been updated (timing rev. A 0.11).
			Figure 3-9. Read/Write Mode (Normal) and Figure 3-10. Read/Write Mode with Input and Output Registers have been updated.
			Table 3-8. Channel output Jitter (Max) has been updated.
Pinout Information	Signal description has been updated. Added 1152-fpBGA pinouts for the ECP2M70 and ECP2M100.		
April 2008	03.1	Pinout Information	Available DDR Interfaces per I/O Bank for the LFE2M35 (484/672-fpBGA) have been updated.
June 2008	03.2	Introduction	Family Selection Guide table - Updated number of EBR SRAM Blocks for the ECP2-70 device.
		Architecture	Removed Read-Before-Write sysMEM EBR mode.
			Clarification of the operation of the secondary clock regions.
DC and Switching Characteristics	Removed Read-Before-Write sysMEM EBR mode.		
August 2008	03.3	Architecture	Clarification of the operation of the secondary clock regions.
		Pinout Information	Added information for [LOC]DQ[num] to Signal Descriptions table.



Стандарт Электрон Связь

Мы молодая и активно развивающаяся компания в области поставок электронных компонентов. Мы поставляем электронные компоненты отечественного и импортного производства напрямую от производителей и с крупнейших складов мира.

Благодаря сотрудничеству с мировыми поставщиками мы осуществляем комплексные и плановые поставки широчайшего спектра электронных компонентов.

Собственная эффективная логистика и склад в обеспечивает надежную поставку продукции в точно указанные сроки по всей России.

Мы осуществляем техническую поддержку нашим клиентам и предпродажную проверку качества продукции. На все поставляемые продукты мы предоставляем гарантию .

Осуществляем поставки продукции под контролем ВП МО РФ на предприятия военно-промышленного комплекса России , а также работаем в рамках 275 ФЗ с открытием отдельных счетов в уполномоченном банке. Система менеджмента качества компании соответствует требованиям ГОСТ ISO 9001.

Минимальные сроки поставки, гибкие цены, неограниченный ассортимент и индивидуальный подход к клиентам являются основой для выстраивания долгосрочного и эффективного сотрудничества с предприятиями радиоэлектронной промышленности, предприятиями ВПК и научно-исследовательскими институтами России.

С нами вы становитесь еще успешнее!

Наши контакты:

Телефон: +7 812 627 14 35

Электронная почта: sales@st-electron.ru

Адрес: 198099, Санкт-Петербург,
Промышленная ул, дом № 19, литера Н,
помещение 100-Н Офис 331