

Low EMI Spread Spectrum Multiplier IC (in Die or Package)

FEATURES

- Spread Spectrum Clock Generator/Multiplier with output selectable from 1x to 8x.
- 13MHz to 240MHz output with output enable.
- 13MHz to 30 MHz reference input frequency accepted from crystal or external clock signal.
- Reduced EMI from Spread Spectrum Modulation, with selectable modulation amplitude for Center Spread, Down Spread or Asymmetric Spread.
- TTL/CMOS compatible outputs.
- 3.3V Operating Voltage.
- 150 ps maximum cycle-to-cycle jitter.
- Available in 16-Pin 150mil SSOP or DIE.

DESCRIPTION

The PLL701-10 is a low EMI Clock Generator and Multiplier for high-speed digital systems. It uses Spread Spectrum Technology (SST) and permits different levels of EMI reduction by selecting the amplitude of the applied SST. The SST feature can be turned off. An output enable input is also used. The chip operates with input frequencies ranging from 13 to 30 MHz and provides 1x to 8x at its output.

OUTPUT CLOCK (FOUT) SELECTION

M2	M1	M0	FIN/XIN (MHz)	Multiplier	FOUT (MHz)
0	0	0	13 ~ 28	X1	13 ~ 28
0	0	1	13 ~ 28	X2	26 ~ 56
0	1	0	14 ~ 30	X3	42 ~ 90
0	1	1	13 ~ 28	X4	52 ~ 112
1	0	0	20 ~ 30	X5	100 ~ 150
1	0	1	17 ~ 30	X6	102 ~ 180
1	1	0	15 ~ 30	X7	105 ~ 210
1	1	1	13 ~ 28	X8	104 ~ 224

BLOCK DIAGRAM

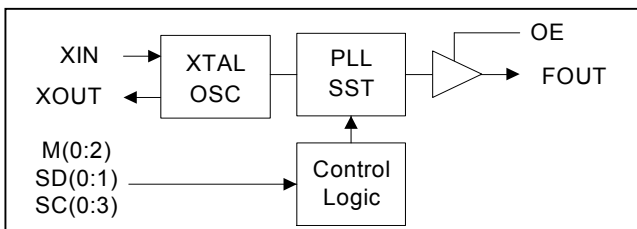

PACKAGE PIN CONFIGURATION

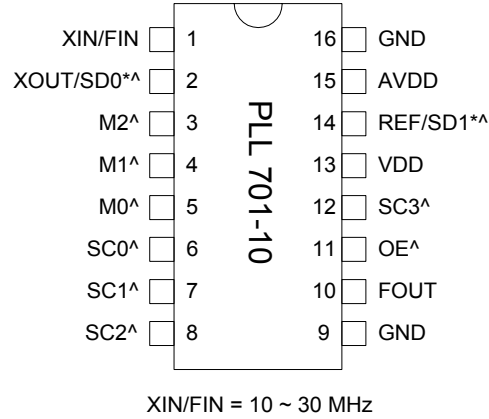

DIE PAD CONFIGURATION

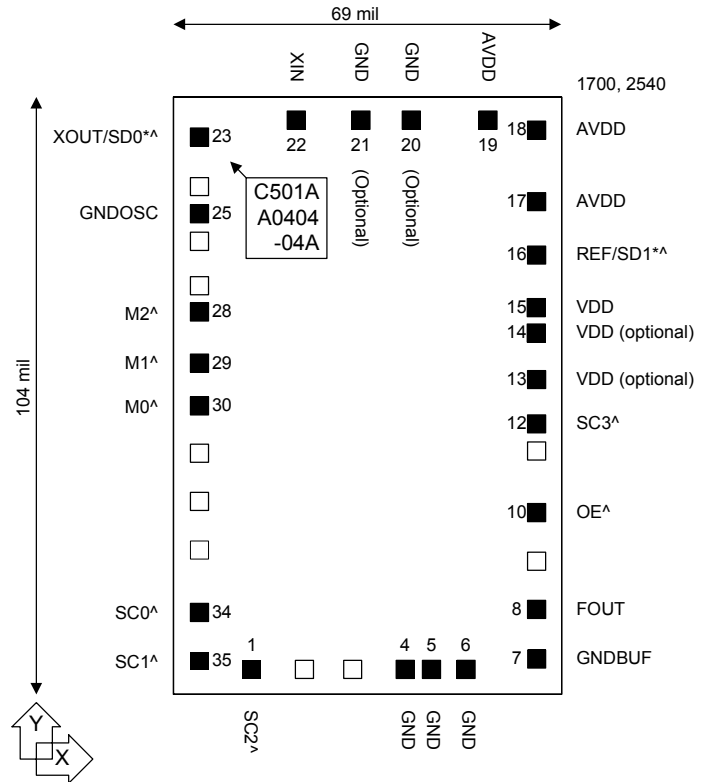

Note: ^: Internal pull-up resistor (120kΩ for SD0, 30 kΩ for SC0-SC2, SD1, M0-M2 and OE). The internal pull-up resistor results in a default high value when no pull-down resistor is connected to this pin.

*: SD0 and SD1 are latched upon power-up.

Low EMI Spread Spectrum Multiplier IC (in Die or Package)

SPREAD SPECTRUM SELECTION TABLE

SD1	SD0	SC3	SC2	SC1	SC0	Modulation Magnitude	Modulation Frequency	Modulation Type
1	1	0	0	0	0	0.250%	Fin / 512	C ± 0.125%
1	1	0	0	0	1	0.500%		C ± 0.25%
1	1	0	0	1	0	0.750%		C ± 0.375%
1	1	0	0	1	1	1.000%		C ± 0.50%
1	0	0	0	1	1			D -1.00%
1	1	0	1	0	0	1.250%		C ± 0.625%
1	0	0	1	0	0			A +0.125 ~ -1.125%
1	1	0	1	0	1	1.500%		C ± 0.75%
1	0	0	1	0	1			A +0.25 ~ -1.25%
1	1	0	1	1	0	1.750%		C ± 0.875%
1	0	0	1	1	0			A +0.375 ~ -1.375%
1	1	0	1	1	1	2.000%		C ± 1.00%
1	0	0	1	1	1			A +0.50 ~ -1.5%
0	1	0	1	1	1			D -2.00%
1	1	1	0	0	0	2.250%		C ± 1.125%
1	0	1	0	0	0			A +0.625 ~ -1.625%
0	1	1	0	0	0			A +0.125 ~ -2.125%
1	1	1	0	0	1	2.500%		C ± 1.25%
0	1	1	0	0	1			A +0.25 ~ -2.25%
1	0	1	0	0	1			A +0.75 ~ -1.75%
1	1	1	0	1	0	2.750%	C ± 1.375%	
1	0	1	0	1	0		A +0.875 ~ -1.875%	
0	1	1	0	1	0		A +0.375 ~ -2.375%	
1	1	1	0	1	1	3.000%	C ± 1.50%	
0	0	1	0	1	1		D -3.00%	
1	0	1	0	1	1		A +1.00 ~ -2.00%	
0	1	1	0	1	1		A +0.50 ~ -2.50%	
1	1	1	1	0	0	3.250%	C ± 1.625%	
1	0	1	1	0	0		A +1.125 ~ -2.125%	
0	1	1	1	0	0		A +0.625 ~ -2.625%	
0	0	1	1	0	0		A +0.125 ~ -3.125%	
1	1	1	1	0	1	3.500%	C ± 1.75%	
1	0	1	1	0	1		A +1.25 ~ -2.25%	
0	1	1	1	0	1		A +0.75 ~ -2.75%	
0	0	1	1	0	1		A +0.25 ~ -3.25%	
1	1	1	1	1	0	3.750%	C ± 1.875%	
1	0	1	1	1	0		A +1.37 ~ -2.375%	
0	1	1	1	1	0		A +0.875 ~ -2.875%	
0	0	1	1	1	0		A +0.375 ~ -3.375%	
1	1	1	1	1	1	0.00 %	SST turned off	
1	0	1	1	1	1		SST turned off	
0	1	1	1	1	1		SST turned off	
0	0	1	1	1	1		SST turned off	

Notes: C: Center Spread. A: Asymmetric Spread. D: Down Spread.

Low EMI Spread Spectrum Multiplier IC (in Die or Package)

PIN/PAD DESCRIPTIONS

Name	Pin #	Pad #	Type	Description
XIN/FIN	1	22	I	Crystal input to be connected to fundamental parallel mode crystal. ($C_L=20\text{pF}$) or clock input.
XOUT/SD0	2	23	B	At power-up, this pin is acts as input pin to select the modulation rate and is latched in. After the input sampling, it is used as crystal output connector. $120\text{k}\Omega$ internal pull up resistor.
M2	3	28	I	Digital control input to select output frequency. $30\text{k}\Omega$ internal pull-up.
M1	4	29	I	Digital control input to select output frequency. $30\text{k}\Omega$ internal pull-up.
M0	5	30	I	Digital control input to select output frequency. $30\text{k}\Omega$ internal pull-up.
SC0	6	34	I	Digital control input to select spread spectrum modulation. $30\text{k}\Omega$ internal pull-up.
SC1	7	35	I	Digital control input to select spread spectrum modulation. $30\text{k}\Omega$ internal pull-up.
SC2	8	1	I	Digital control input to select spread spectrum modulation. $30\text{k}\Omega$ internal pull-up.
SC3	12	12	I	Digital control input to select spread spectrum modulation. $30\text{k}\Omega$ internal pull-up.
FOUT	10	8	O	Modulated Clock Frequency Output. The frequency before modulation is synthesized by multiplying the input frequency by 1X to 8X, depending on SD(0:1) and SC(0:3).
OE	11	10	I	Output Enable. When low, Tri-states all outputs. $30\text{k}\Omega$ internal pull-up.
VDD	13	13,14,15	P	3.3V Power Supply.
REF/SD1	14	16	B	At power-up, this pin acts as input pin to select the modulation rate and is latched in. After the input sampling, this pin provides a buffered Reference Clock Output of the same frequency as the crystal or clock input. $30\text{k}\Omega$ internal pull-up.
AVDD	15	17,18,19	P	3.3V Analog power supply.
GNDOSC	N/A	25	P	Ground for Oscillator circuitry.
GNDBUF	N/A	7	P	Ground for output buffer circuitry.
GND	9 and 16	4,5,6,20,21	P	Ground.

Notes: B – bi-directional pin; I – input pin; P – power supply/ground pin.

DIE SPECIFICATIONS

Name	Value
Size	104 x 69 mil
Reverse side	GND
Pad dimensions	80 micron x 80 micron
Thickness	10 mil

Low EMI Spread Spectrum Multiplier IC (in Die or Package)

FUNCTIONAL DESCRIPTION

Selectable spread spectrum and modulation rates

The PLL701-10 provides selectable multiplier factors (1x to 8X), selectable spread spectrum modulation, as well as selectable modulation rate. Selection is made by connecting specific input pins to a logical “zero” or “one”. Pins 6 (SC0), 7 (SC1), 8 (SC2) and 12 (SC3) are used as inputs to select the spread spectrum modulation as shown on the spread spectrum selection table (page 2). Pins 3 (M2), 4 (M1), 5 (M0) are used as inputs to select the output frequency as shown on the output clock selection table (page 1). Pin 11 is the output enable pin, that tri-states all outputs when low (logical “zero”).

In order to reduce the number of pins on the chip, the PLL701-10 uses pin 2 and 14 (XOUT/SD0 and REF/SD1) as a bi-directional pin. The pins serve as modulation rate selector inputs (SD0 and SD1) upon power-up (see modulation rate table on page 1), and as XOUT crystal connection (pin 2), and REF output signal (pin 14) as soon as the inputs have been latched.

Connecting a selection pin to a logical “one”

All selection pins have an internal pull-up resistor (30kΩ for pins 3, 4, 5, 6, 7, 8, 11, 12, 14 and 120kΩ for pin 2). This internal pull-up resistor will pull the input value to a logical “one” (pull-up) by default, i.e. when no resistive load is connected between the pin and GND. No external pull-up resistor is therefore required for connecting a logical “one” upon power-up.

Connecting a selection pin to a logical “zero”

For an input only pin, i.e. all input pins except XOUT/SD0 (pin 2) and REF/SD1 (pin 14), the pin simply needs to be grounded to pull the input down to a logical “zero”. Connecting the bi-directional pins (SD0 and SD1) to a logical “zero” will however require the use of an external loading resistor between the pin and GND that has to be sufficiently small (compared to the internal pull-up resistor) so that the pin voltage be pulled below 0.8V (logical “zero”). In order to avoid loading effects when the pin serves as output, the value of the external pull-down resistor should however be kept as large as possible. In general, it is recommended to use an external resistor of around $R_{up}/4$ (e.g. 27kΩ for pin 2 and 4.7kΩ for pin 14, see Application Diagram).

APPLICATION DIAGRAM FOR OUTPUT AND MODULATION SELECTION

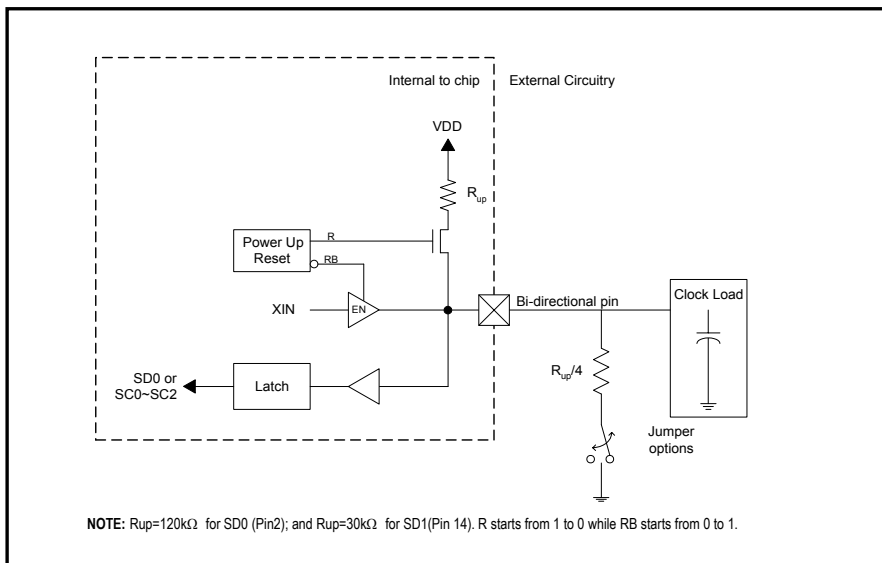

Low EMI Spread Spectrum Multiplier IC (in Die or Package)

ELECTRICAL SPECIFICATIONS

1. Absolute Maximum Ratings

PARAMETERS	SYMBOL	MIN.	MAX.	UNITS
Supply Voltage	V_{DD}		4.6	V
Input Voltage, dc	V_I	-0.5	$V_{DD}+0.5$	V
Output Voltage, dc	V_O	-0.5	$V_{DD}+0.5$	V
Storage Temperature	T_S	-65	150	°C
Ambient Operating Temperature*	T_A	-40	85	°C
Junction Temperature	T_J		125	°C
Lead Temperature (soldering, 10s)			260	°C
ESD Protection, Human Body Model			2	kV

Exposure of the device under conditions beyond the limits specified by Maximum Ratings for extended periods may cause permanent damage to the device and affect product reliability. These conditions represent a stress rating only, and functional operations of the device at these or any other conditions above the operational limits noted in this specification is not implied.

* **Note:** Operating Temperature is guaranteed by design for all parts (COMMERCIAL and INDUSTRIAL), but tested for COMMERCIAL grade only.

2. DC/AC Specifications

PARAMETERS	SYMBOL	CONDITIONS	MIN.	TYP.	MAX.	UNITS
Supply Voltage	V_{DD}		2.97		3.63	V
Input High Voltage	V_{IH}		$0.7 \cdot V_{DD}$			V
Input Low Voltage	V_{IL}				$0.3 \cdot V_{DD}$	V
Input High Current	I_{IH}				100	μA
Input Low Current	I_{IL}				100	μA
Output High Voltage	V_{OH}	$I_{OH}=5mA, V_{DD}=3.3V$	2.4			
Output Low Voltage	V_{OL}	$I_{OL}=6mA, V_{DD}=3.3V$			0.4	
Input Frequency	F_{XIN}	When using a crystal	15		30	MHz
	F_{IN}	When using reference clock	15		30	MHz
Maximum interruption of F_{IN}		When using reference clock			100	μs
Load Capacitance	C_L	Between Pin XIN and XOUT*		18		pF
Pull-up Resistor	R_{up}	PIN 2		120		$k\Omega$
Pull-up Resistor	R_{up}	PIN 3,4,5,6,7,8,11,12		30		$k\Omega$
Short Circuit Current	I_{sc}			25		mA
3.3V Dynamic Supply Current	I_{CC}	No Load		20		mA

***Note:** Pin XIN and XOUT each has a 36pF capacitance. When used with a XTAL, the two capacitors combined load the crystal with 18pF. If driving XIN with a reference clock signal, the load capacitance will be 36pF (typical).

Low EMI Spread Spectrum Multiplier IC (in Die or Package)

3. TIMING CHARACTERISTICS

PARAMETERS	SYMBOL	CONDITIONS	MIN.	TYP.	MAX.	UNITS
Rise Time	T_r	Measured at 0.8V ~ 2.0V @ 3.3V	0.8	0.95	1.1	ns
Fall Time	T_f	Measured at 2.0V ~ 0.8V @ 3.3V	0.78	0.85	0.9	ns
Output Duty Cycle	D_T		45	50	55	%
Cycle to Cycle Jitter	$T_{cyc-cyc}$	X1, X2, X4, X8 FOUT @ 3.3V			100	ps
Cycle to Cycle Jitter	$T_{cyc-cyc}$	X3, X5, X6, X7 FOUT @ 3.3V			150	ps

Low EMI Spread Spectrum Multiplier IC (in Die or Package)

PAD ASSIGNMENT (LOWER LEFT CORNER: X = 0, Y = 0)

Pad #	Name	X (μm)	Y (μm)
1	SC2	338.9	104.7
2	N/C	569	104.7
3	N/C	780.5	104.7
4	GND	1027.6	104.7
5	GND	1127.3	104.7
6	GND	1284.5	104.7
7	GNDBUF	1595.1	139.7
8	FOUT	1595.1	381.7
9	N/C	1595.1	596.3
10	OE	1595.1	811.9
11	N/C	1595.1	970.3
12	SC3	1595.1	1069.3
13	VDD (Optional)	1595.1	1312.3
14	VDD (Optional)	1595.1	1555.6
15	VDD	1595.1	1656.8
16	REF/SD1	1595.1	1879.9
17	AVDD	1595.1	2093
18	AVDD	1595.1	2390.6
19	AVDD	1369.2	2435
20	GND (Optional)	1037.3	2435
21	GND (Optional)	824.7	2435
22	XIN	529.7	2435
23	XOUT/SD0	105.6	2343.5
24	N/C	105.6	2136.1
25	GNDOSC	105.6	2035.6
26	N/C	105.6	1934.9
27	N/C	105.6	1741.5
28	M2	105.6	1641.4
29	M1	105.6	1396.2
30	N/C	105.6	1180.3
31	N/C	105.6	993.5
32	N/C	105.6	836.7
33	N/C	105.6	680.1
34	SC0	105.6	354.9
35	SC1	105.6	110.7

Low EMI Spread Spectrum Multiplier IC (in Die or Package)

PACKAGE INFORMATION

16 PIN SSOP

Symbol	mm		BSC	
	Min.	Max.	Min.	Max.
A	1.35	1.75	0.053	0.069
A1	0.10	0.25	0.004	0.010
B	0.20	0.30	0.008	0.012
C	0.18	0.25	0.007	0.010
D	4.80	5.00	0.189	0.197
E	3.81	3.99	0.150	0.157
H	5.79	6.20	0.228	0.244
L	0.41	1.27	0.016	0.050
e	0.635 BASIC		0.025 BASIC	

ORDERING INFORMATION

For part ordering, please contact our Sales Department:

47745 Fremont Blvd., Fremont, CA 94538, USA
Tel: (510) 492-0990 Fax: (510) 492-0991

PART NUMBER

The order number for this device is a combination of the following:
Device number, Package type and Operating temperature range

PLL701-10 X C

PART NUMBER

TEMPERATURE
C=COMMERCIAL
I=INDUSTRIAL

PACKAGE TYPE
X=SSOP; D=DIE

Order Number	Marking	Package Option
PLL701-10XC	P701-10XC	SSOP –Tubes
PLL701-10XC-R	P701-10XC	SSOP –Tape & Reel
PLL701-10DC	P701-10DC	Die –Waffle Pack

PhaseLink Corporation, reserves the right to make changes in its products or specifications, or both at any time without notice. The information furnished by Phaselink is believed to be accurate and reliable. However, PhaseLink makes no guarantee or warranty concerning the accuracy of said information and shall not be responsible for any loss or damage of whatever nature resulting from the use of, or reliance upon this product.

LIFE SUPPORT POLICY: PhaseLink's products are not authorized for use as critical components in life support devices or systems without the express written approval of the President of PhaseLink Corporation.



Стандарт Электрон Связь

Мы молодая и активно развивающаяся компания в области поставок электронных компонентов. Мы поставляем электронные компоненты отечественного и импортного производства напрямую от производителей и с крупнейших складов мира.

Благодаря сотрудничеству с мировыми поставщиками мы осуществляем комплексные и плановые поставки широчайшего спектра электронных компонентов.

Собственная эффективная логистика и склад в обеспечивает надежную поставку продукции в точно указанные сроки по всей России.

Мы осуществляем техническую поддержку нашим клиентам и предпродажную проверку качества продукции. На все поставляемые продукты мы предоставляем гарантию .

Осуществляем поставки продукции под контролем ВП МО РФ на предприятия военно-промышленного комплекса России , а также работаем в рамках 275 ФЗ с открытием отдельных счетов в уполномоченном банке. Система менеджмента качества компании соответствует требованиям ГОСТ ISO 9001.

Минимальные сроки поставки, гибкие цены, неограниченный ассортимент и индивидуальный подход к клиентам являются основой для выстраивания долгосрочного и эффективного сотрудничества с предприятиями радиоэлектронной промышленности, предприятиями ВПК и научно-исследовательскими институтами России.

С нами вы становитесь еще успешнее!

Наши контакты:

Телефон: +7 812 627 14 35

Электронная почта: sales@st-electron.ru

Адрес: 198099, Санкт-Петербург,
Промышленная ул, дом № 19, литера Н,
помещение 100-Н Офис 331