

## Low current 1.2 to 37V adjustable voltage regulator

### Features

- Output voltage range: 1.2 to 37V
- Output current in excess of 100 mA
- Line regulation typ. 0.01%
- Load regulation typ. 0.1%
- Thermal overload protection
- Short circuit protection
- Output transition safe area compensation
- Floating operation for high voltage applications

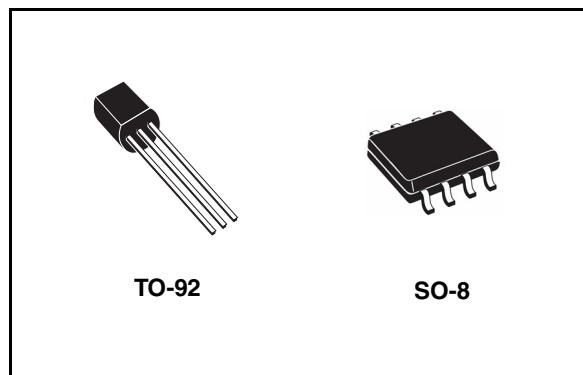

### Description

The LM217L/LM317L are monolithic integrated circuit in SO-8 and TO-92 packages intended for use as positive adjustable voltage regulators.

They are designed to supply until 100 mA of load current with an output voltage adjustable over a 1.2 to 37V range.

The nominal output voltage is selected by means of only a resistive divider, making the device exceptionally easy to use and eliminating the stocking of many fixed regulators.

### Order codes

Part numbers	Packages	
	SO-8 (Tape & reel)	TO-92 (BAG) <sup>(1)</sup>
LM217L	LM217LD13TR	LM217LZ
LM317L	LM317LD13TR	LM317LZ

1. Available in tape & reel with the suffix "-TR" and in Ammopak with the suffix "-AP". Please note that in these cases pins are shaped according to tape & reel specifications

---

# Contents

1	Diagram .....	3
2	Pin configuration .....	4
3	Maximum ratings .....	5
4	Electrical characteristics .....	6
5	Typical performance .....	8
6	Application information .....	9
7	Application circuits .....	10
8	Package mechanical data .....	12
9	Revision history .....	17

# 1 Diagram

Figure 1. Schematic diagram

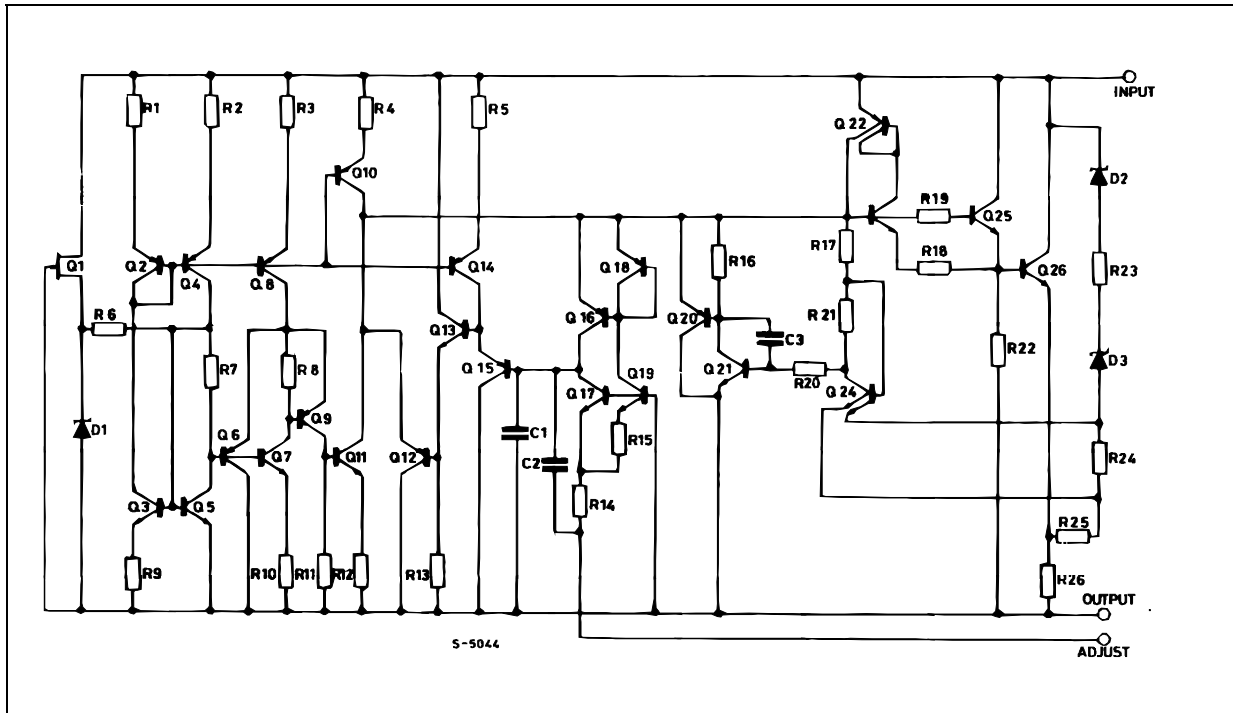

## 2 Pin configuration

Figure 2. Pin connections (top view for SO-8, bottom view for TO-92)

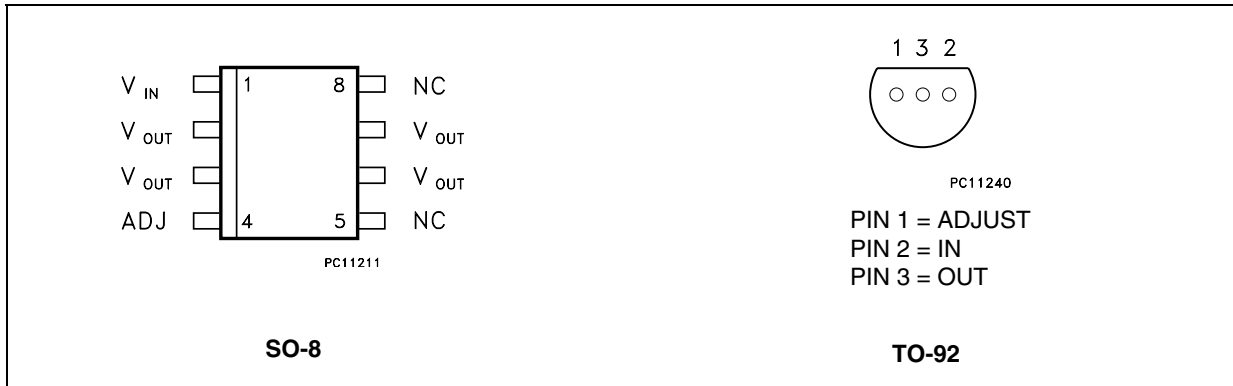

### 3 Maximum ratings

**Table 1. Absolute maximum ratings**

Symbol	Parameter	Value	Unit
$V_{I-V_O}$	Input-output differential voltage	40	V
$P_D$	Power dissipation	Internally Limited	mW
$T_{OP}$	Operating junction temperature range	for LM217L	-40 to 125
		for LM317L	0 to 125
$T_{STG}$	Storage temperature range	-55 to 150	°C

**Figure 3. Test circuit**

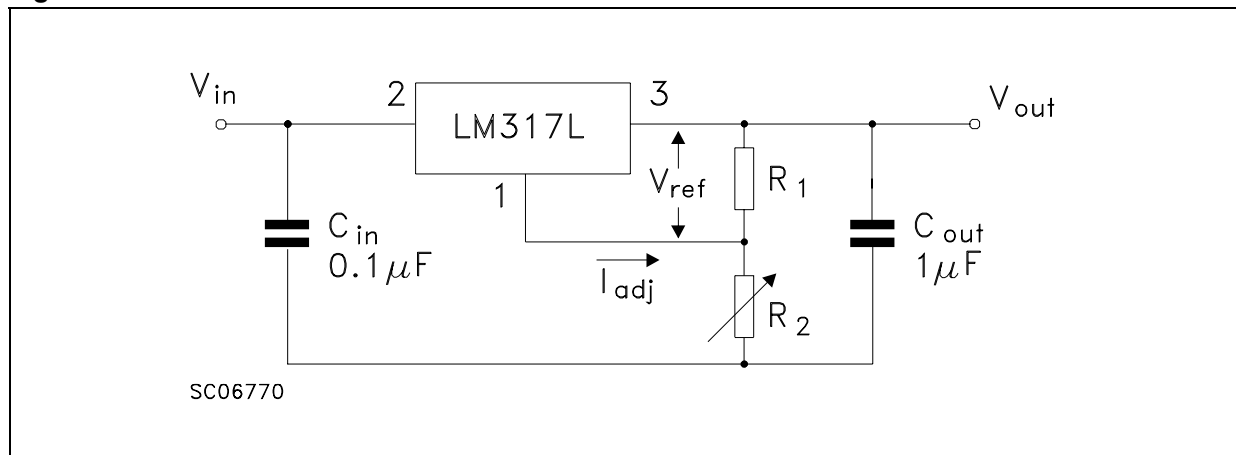

## 4 Electrical characteristics

**Table 2. Electrical characteristics of LM217L** (refer to the test circuits,  $T_J = -40$  to  $125^\circ\text{C}$ ,  $V_I - V_O = 5\text{ V}$ ,  $I_O = 40\text{ mA}$ , unless otherwise specified)

Symbol	Parameter	Test conditions		Min.	Typ.	Max.	Unit
$\Delta V_O$	Line regulation	$V_I - V_O = 3$ to $40\text{ V}$ $I_L < 20\text{ mA}$	$T_J = 25^\circ\text{C}$		0.01	0.02	%V
					0.02	0.05	
$\Delta V_O$	Load regulation	$V_O \leq 5\text{ V}$ $I_O = 5$ to $100\text{ mA}$	$T_J = 25^\circ\text{C}$		5	15	mV
					20	50	
		$V_O \geq 5\text{ V}$ $I_O = 5$ to $100\text{ mA}$	$T_J = 25^\circ\text{C}$		0.1	0.3	%
					0.3	1	
$I_{ADJ}$	Adjustment pin current			50	100	$\mu\text{A}$	
$\Delta I_{ADJ}$	Adjustment pin current	$V_I - V_O = 3$ to $40\text{ V}$ , $I_O = 5$ to $100\text{ mA}$ $P_d < 625\text{ mW}$			0.2	5	$\mu\text{A}$
$V_{REF}$	Reference voltage	$V_I - V_O = 3$ to $40\text{ V}$ , $I_O = 10$ to $500\text{ mA}$ $P_d < 625\text{ mW}$		1.2	1.25	1.3	V
$\Delta V_O/V_O$	Output voltage temperature stability				0.7		%
$I_{O(\min)}$	Minimum load current	$V_I - V_O = 40\text{ V}$			3.5	5	mA
$I_{O(\max)}$	Maximum output current	$V_I - V_O = 3$ to $13\text{ V}$		100	200		mA
		$V_I - V_O = 40\text{ V}$			50		
eN	Output noise voltage	B = 10 Hz to 10 KHz, $T_J = 25^\circ\text{C}$			0.003		%
SVR	Supply voltage rejection <sup>(1)</sup>	$T_J = 25^\circ\text{C}$ $f = 120\text{ Hz}$	$C_{ADJ} = 0$		65		dB
			$C_{ADJ} = 10\ \mu\text{F}$	66	80		

1.  $C_{ADJ}$  is connected between adjust pin and ground.

**Table 3. Electrical characteristics of LM317L** (refer to the test circuits,  $T_J = 0$  to  $125^\circ\text{C}$ ,  $V_I - V_O = 5$  V,  $I_O = 40$  mA, unless otherwise specified)

Symbol	Parameter	Test conditions		Min.	Typ.	Max.	Unit
$\Delta V_O$	Line regulation	$V_I - V_O = 3$ to $40$ V $I_L < 20$ mA	$T_J = 25^\circ\text{C}$		0.01	0.04	%V
					0.02	0.07	
$\Delta V_O$	Load regulation	$V_O \leq 5$ V $I_O = 5$ to $100$ mA	$T_J = 25^\circ\text{C}$		5	25	mV
					20	70	
		$V_O \geq 5$ V $I_O = 5$ to $100$ mA	$T_J = 25^\circ\text{C}$		0.1	0.5	%
					0.3	1.5	
$I_{ADJ}$	Adjustment pin current			50	100	$\mu\text{A}$	
$\Delta I_{ADJ}$	Adjustment pin current	$V_I - V_O = 3$ to $40$ V, $I_O = 5$ to $100$ mA $P_d < 625$ mW		0.2	5	$\mu\text{A}$	
$V_{REF}$	Reference voltage	$V_I - V_O = 3$ to $40$ V, $I_O = 5$ to $100$ mA $P_d < 625$ mW		1.2	1.25	1.3	V
$\Delta V_O/V_O$	Output voltage temperature stability				0.7		%
$I_{O(\min)}$	Minimum load current	$V_I - V_O = 40$ V			3.5	5	mA
$I_{O(\max)}$	Maximum output current	$V_I - V_O = 3$ to $13$ V		100	200		mA
		$V_I - V_O = 40$ V			50		
eN	Output noise voltage	$B = 10$ Hz to $10$ KHz, $T_J = 25^\circ\text{C}$			0.003		%
SVR	Supply voltage rejection <sup>(1)</sup>	$T_J = 25^\circ\text{C}$ $f = 120$ Hz	$C_{ADJ} = 0$		65		dB
			$C_{ADJ} = 10$ $\mu\text{F}$	66	80		

1.  $C_{ADJ}$  is connected between adjust pin and ground.

# 5 Typical performance

Figure 4. Current limit

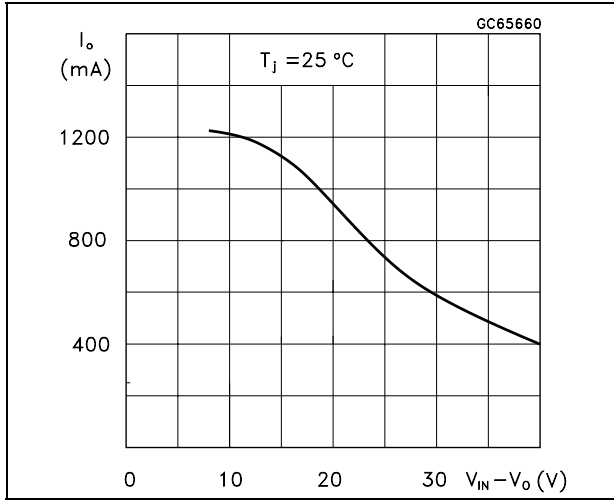
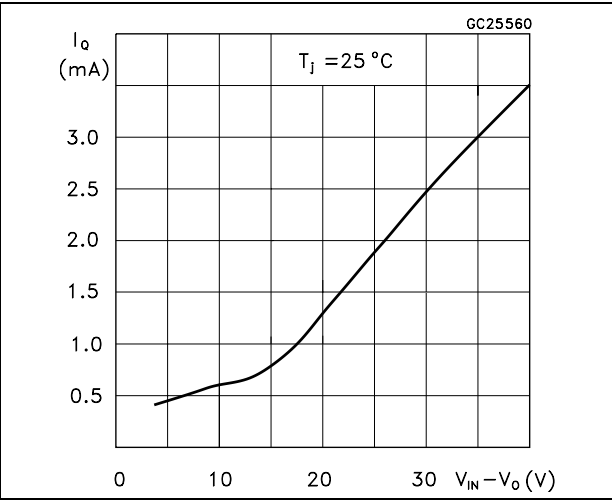

Figure 5. Minimum operating current





## 6 Application information

The LM317L provides an internal reference voltage of 1.25V between the output and adjustments terminals. This is used to set a constant current flow across an external resistor divider (see [Figure 4.](#)), giving an output voltage  $V_O$  of:

$$V_O = V_{REF} (1 + R_2/R_1) + I_{ADJ} R_2$$

The device was designed to minimize the term  $I_{ADJ}$  (100 $\mu$ A max) and to maintain it very constant with line and load changes. Usually, the error term  $I_{ADJ} \times R_2$  can be neglected. To obtain the previous requirement, all the regulator quiescent current is returned to the output terminal, imposing a minimum load current condition. If the load is insufficient, the output voltage will rise.

Since the LM317L is a floating regulator and "sees" only the input-to-output differential voltage, supplies of very high voltage with respect to ground can be regulated as long as the maximum input-to-output differential is not exceeded. Furthermore, programmable regulator are easily obtainable and, by connecting a fixed resistor between the adjustment and output, the device can be used as a precision current regulator. In order to optimize the load regulation, the current set resistor  $R_1$  (see [Figure 4.](#)) should be tied as close as possible to the regulator, while the ground terminal of  $R_2$  should be near the ground of the load to provide remote ground sensing.

## 7 Application circuits

Figure 6. Basic adjustable regulator

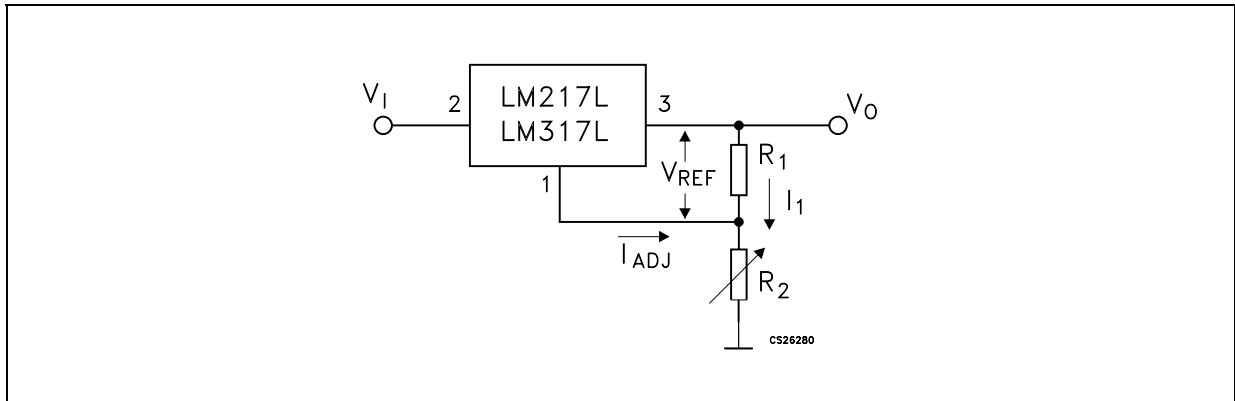

Figure 7. Voltage regulator with protection diodes

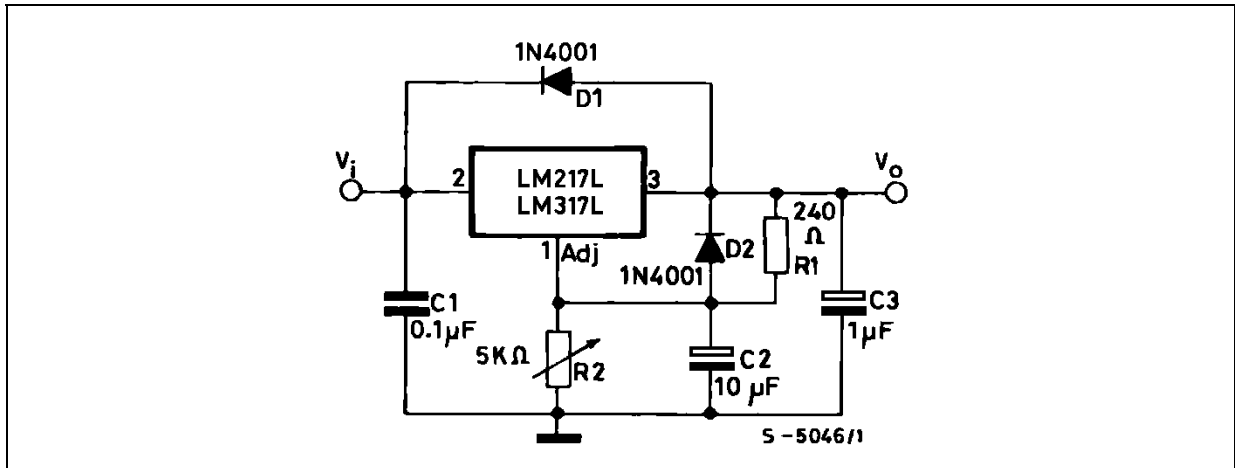

Figure 8. Slow Turn-on 15V Regulator

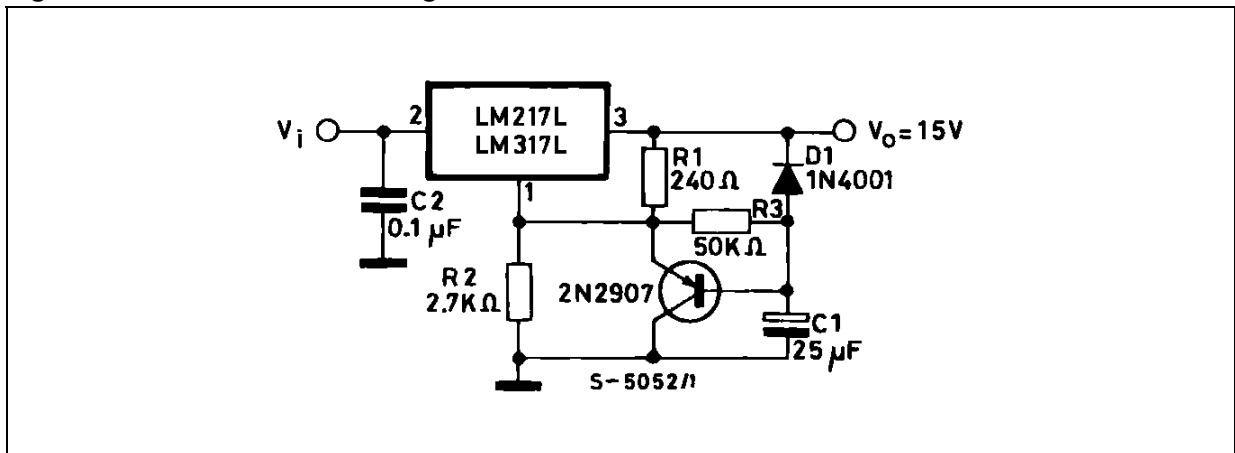

Figure 9. Current regulator

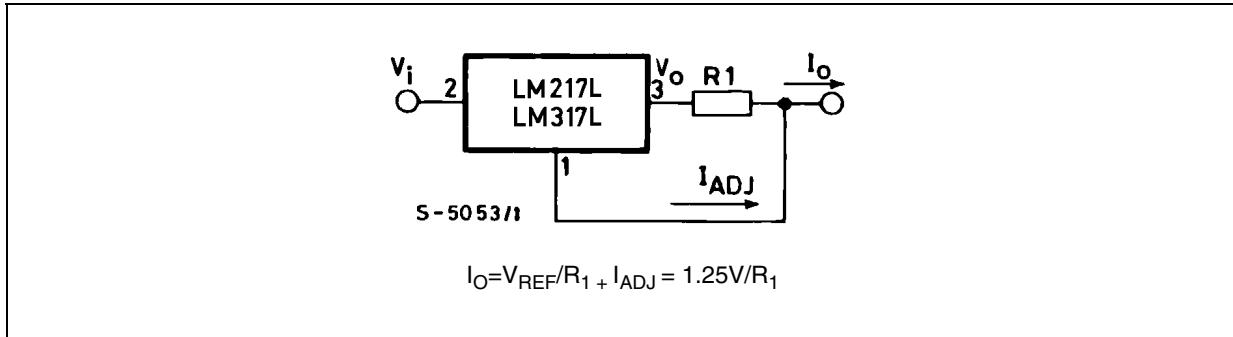

Figure 10. 5V Electronic shut-down regulator

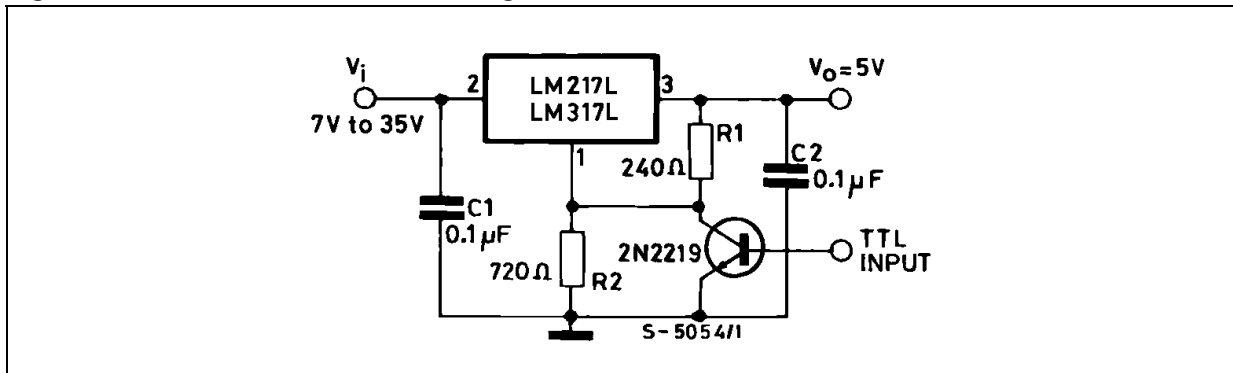
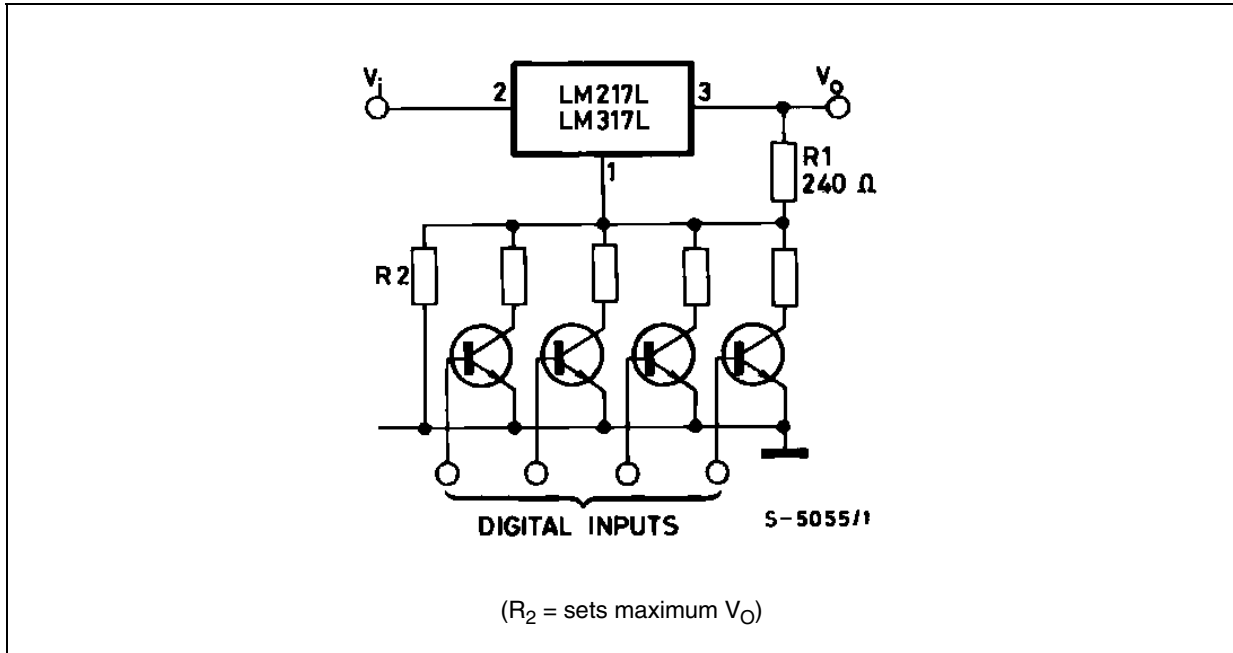

Figure 11. Digitally selected outputs



## 8 Package mechanical data

In order to meet environmental requirements, ST offers these devices in ECOPACK<sup>®</sup> packages. These packages have a Lead-free second level interconnect. The category of second Level Interconnect is marked on the package and on the inner box label, in compliance with JEDEC Standard JESD97. The maximum ratings related to soldering conditions are also marked on the inner box label. ECOPACK is an ST trademark. ECOPACK specifications are available at: [www.st.com](http://www.st.com).

**SO-8 MECHANICAL DATA**

DIM.	mm.			inch		
	MIN.	TYP	MAX.	MIN.	TYP.	MAX.
A	1.35		1.75	0.053		0.069
A1	0.10		0.25	0.04		0.010
A2	1.10		1.65	0.043		0.065
B	0.33		0.51	0.013		0.020
C	0.19		0.25	0.007		0.010
D	4.80		5.00	0.189		0.197
E	3.80		4.00	0.150		0.157
e		1.27			0.050	
H	5.80		6.20	0.228		0.244
h	0.25		0.50	0.010		0.020
L	0.40		1.27	0.016		0.050
k	8° (max.)					
ddd			0.1			0.04

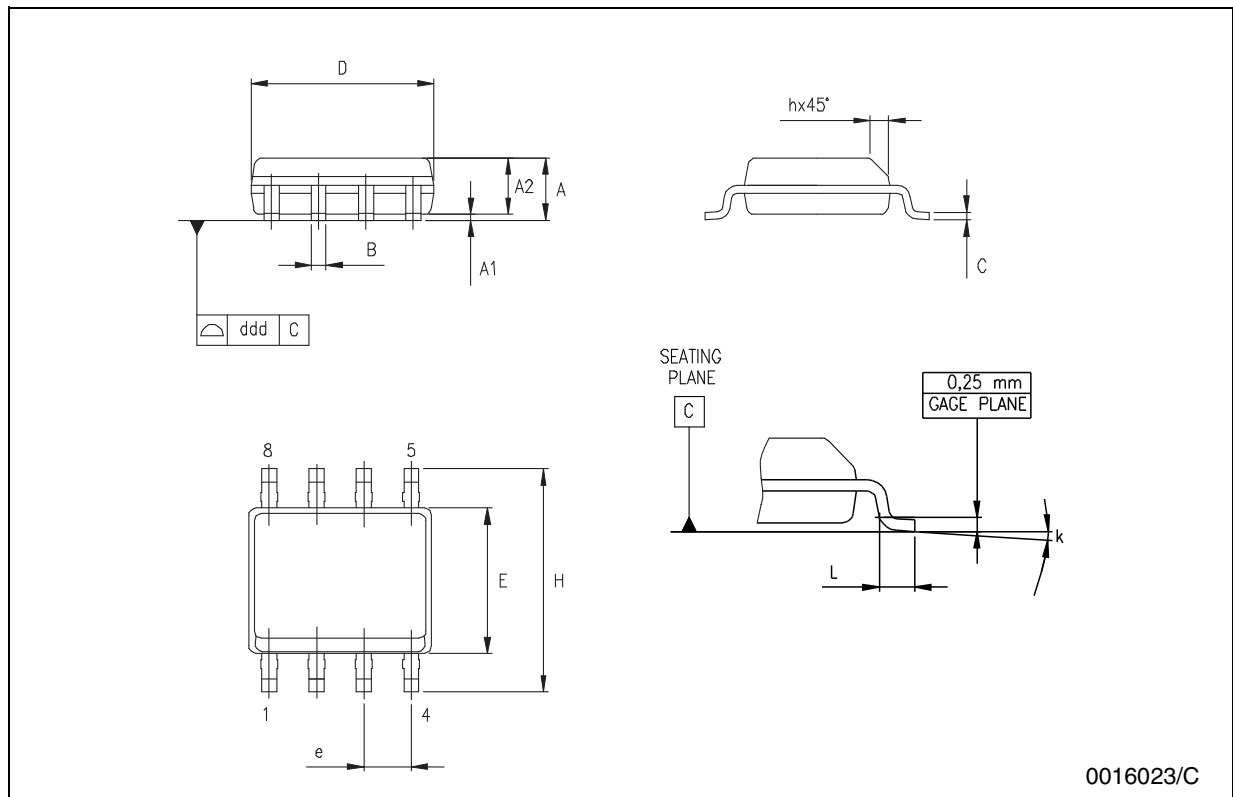

0016023/C

**TO-92 MECHANICAL DATA**

DIM.	mm.			mils		
	MIN.	TYP	MAX.	MIN.	TYP.	MAX.
A	4.32		4.95	170.1		194.9
b	0.36		0.51	14.2		20.1
D	4.45		4.95	175.2		194.9
E	3.30		3.94	129.9		155.1
e	2.41		2.67	94.9		105.1
e1	1.14		1.40	44.9		55.1
L	12.7		15.49	500.0		609.8
R	2.16		2.41	85.0		94.9
S1	0.92		1.52	36.2		59.8
W	0.41		0.56	16.1		22.0
$\alpha$		5°			5°	

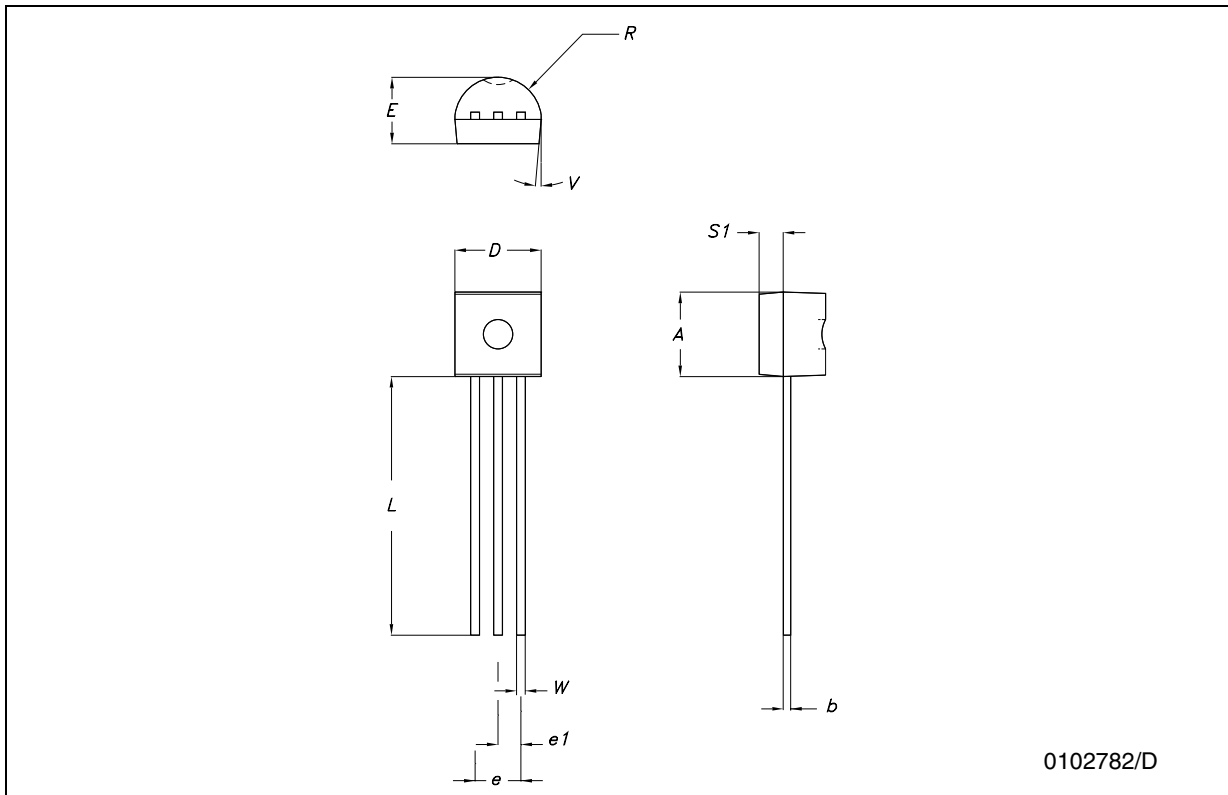

0102782/D

**Tape & Reel SO-8 MECHANICAL DATA**

DIM.	mm.			inch		
	MIN.	TYP	MAX.	MIN.	TYP.	MAX.
A			330			12.992
C	12.8		13.2	0.504		0.519
D	20.2			0.795		
N	60			2.362		
T			22.4			0.882
Ao	8.1		8.5	0.319		0.335
Bo	5.5		5.9	0.216		0.232
Ko	2.1		2.3	0.082		0.090
Po	3.9		4.1	0.153		0.161
P	7.9		8.1	0.311		0.319

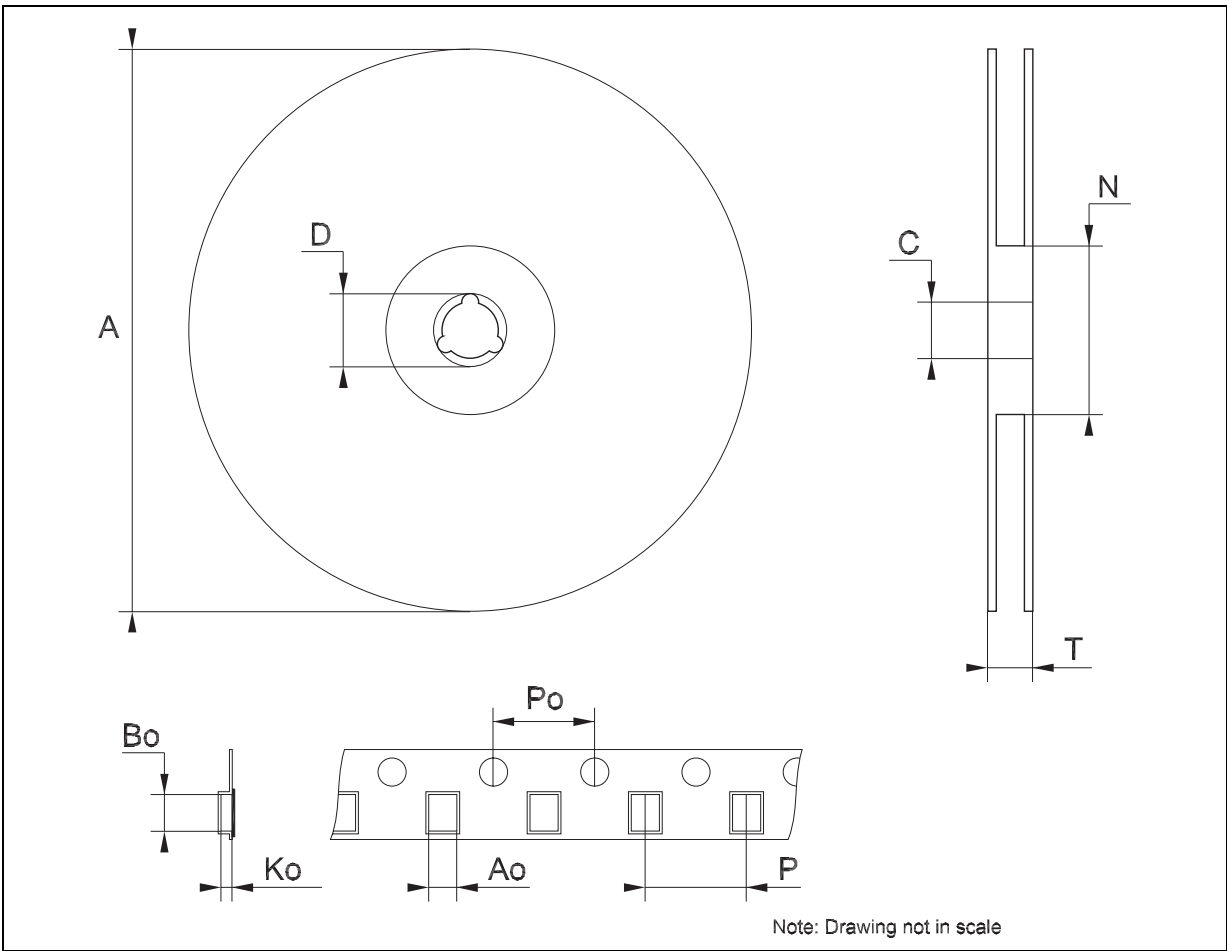

**Tape & Reel for TO-92 MECHANICAL DATA**

DIM.	mm.			inch		
	MIN.	TYP.	MAX.	MIN.	TYP.	MAX.
A1		4.80			0.189	
T		3.80			0.150	
T1		1.60			0.063	
T2		2.30			0.091	
d		0.48			0.019	
P0	12.5		12.9	0.492		0.508
P2	5.65		7.05	0.222		0.278
F1, F2	2.44	2.54	2.94	0.096	0.100	0.116
delta H		±2			0.079	
W	17.5	18.00	19.0	0.689	0.709	0.748
W0	5.7		6.3	0.224		0.248
W1	8.5		9.25	0.335		0.364
W2		0.50			0.20	
H		18.50	18.70		0.728	0.726
H0	15.50		16.50	0.610		0.650
H1		25.00			0.984	
D0	3.8		4.2	0.150		0.165
t		0.90			0.035	
L1		3			0.118	
delta P		±1			0.039	
u		50			1.968	
Φ1		360			14.173	
Φ2		30			1.181	

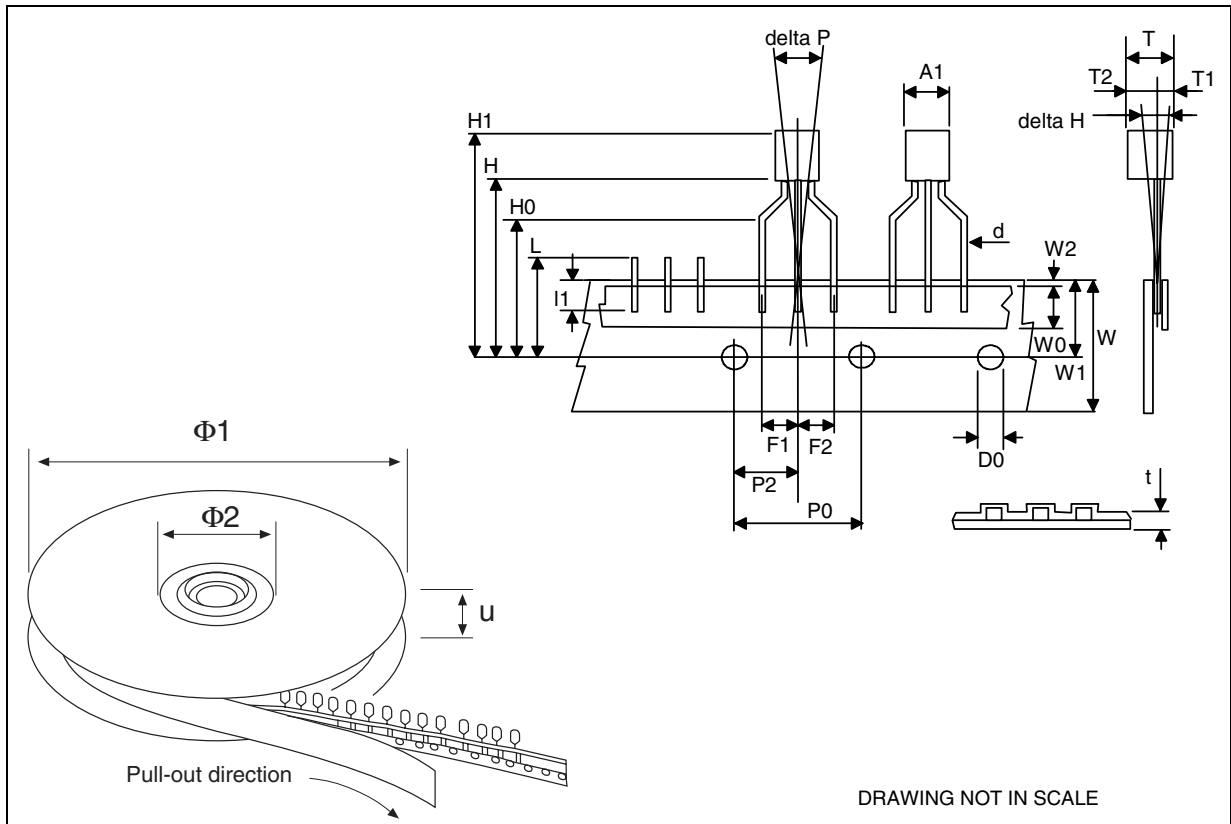



## 9 Revision history

**Table 4. Revision history**

<b>Date</b>	<b>Revision</b>	<b>Changes</b>
16-Mar-2005	2	Add Tape & reel for TO-92.
23-Dec-2005	3	Mistake on ordering table in header.
18-May-2007	4	Order codes has been updated and the document has been reformatted.

**Please Read Carefully:**

Information in this document is provided solely in connection with ST products. STMicroelectronics NV and its subsidiaries ("ST") reserve the right to make changes, corrections, modifications or improvements, to this document, and the products and services described herein at any time, without notice.

All ST products are sold pursuant to ST's terms and conditions of sale.

Purchasers are solely responsible for the choice, selection and use of the ST products and services described herein, and ST assumes no liability whatsoever relating to the choice, selection or use of the ST products and services described herein.

No license, express or implied, by estoppel or otherwise, to any intellectual property rights is granted under this document. If any part of this document refers to any third party products or services it shall not be deemed a license grant by ST for the use of such third party products or services, or any intellectual property contained therein or considered as a warranty covering the use in any manner whatsoever of such third party products or services or any intellectual property contained therein.

**UNLESS OTHERWISE SET FORTH IN ST'S TERMS AND CONDITIONS OF SALE ST DISCLAIMS ANY EXPRESS OR IMPLIED WARRANTY WITH RESPECT TO THE USE AND/OR SALE OF ST PRODUCTS INCLUDING WITHOUT LIMITATION IMPLIED WARRANTIES OF MERCHANTABILITY, FITNESS FOR A PARTICULAR PURPOSE (AND THEIR EQUIVALENTS UNDER THE LAWS OF ANY JURISDICTION), OR INFRINGEMENT OF ANY PATENT, COPYRIGHT OR OTHER INTELLECTUAL PROPERTY RIGHT.**

**UNLESS EXPRESSLY APPROVED IN WRITING BY AN AUTHORIZED ST REPRESENTATIVE, ST PRODUCTS ARE NOT RECOMMENDED, AUTHORIZED OR WARRANTED FOR USE IN MILITARY, AIR CRAFT, SPACE, LIFE SAVING, OR LIFE SUSTAINING APPLICATIONS, NOR IN PRODUCTS OR SYSTEMS WHERE FAILURE OR MALFUNCTION MAY RESULT IN PERSONAL INJURY, DEATH, OR SEVERE PROPERTY OR ENVIRONMENTAL DAMAGE. ST PRODUCTS WHICH ARE NOT SPECIFIED AS "AUTOMOTIVE GRADE" MAY ONLY BE USED IN AUTOMOTIVE APPLICATIONS AT USER'S OWN RISK.**

Resale of ST products with provisions different from the statements and/or technical features set forth in this document shall immediately void any warranty granted by ST for the ST product or service described herein and shall not create or extend in any manner whatsoever, any liability of ST.

ST and the ST logo are trademarks or registered trademarks of ST in various countries.

Information in this document supersedes and replaces all information previously supplied.

The ST logo is a registered trademark of STMicroelectronics. All other names are the property of their respective owners.

© 2007 STMicroelectronics - All rights reserved

STMicroelectronics group of companies

Australia - Belgium - Brazil - Canada - China - Czech Republic - Finland - France - Germany - Hong Kong - India - Israel - Italy - Japan - Malaysia - Malta - Morocco - Singapore - Spain - Sweden - Switzerland - United Kingdom - United States of America

[www.st.com](http://www.st.com)



## Стандарт Электрон Связь

Мы молодая и активно развивающаяся компания в области поставок электронных компонентов. Мы поставляем электронные компоненты отечественного и импортного производства напрямую от производителей и с крупнейших складов мира.

Благодаря сотрудничеству с мировыми поставщиками мы осуществляем комплексные и плановые поставки широчайшего спектра электронных компонентов.

Собственная эффективная логистика и склад в обеспечивает надежную поставку продукции в точно указанные сроки по всей России.

Мы осуществляем техническую поддержку нашим клиентам и предпродажную проверку качества продукции. На все поставляемые продукты мы предоставляем гарантию .

Осуществляем поставки продукции под контролем ВП МО РФ на предприятия военно-промышленного комплекса России , а также работаем в рамках 275 ФЗ с открытием отдельных счетов в уполномоченном банке. Система менеджмента качества компании соответствует требованиям ГОСТ ISO 9001.

Минимальные сроки поставки, гибкие цены, неограниченный ассортимент и индивидуальный подход к клиентам являются основой для выстраивания долгосрочного и эффективного сотрудничества с предприятиями радиоэлектронной промышленности, предприятиями ВПК и научно-исследовательскими институтами России.

С нами вы становитесь еще успешнее!

### Наши контакты:

**Телефон:** +7 812 627 14 35

**Электронная почта:** [sales@st-electron.ru](mailto:sales@st-electron.ru)

**Адрес:** 198099, Санкт-Петербург,  
Промышленная ул, дом № 19, литера Н,  
помещение 100-Н Офис 331