

General Description

The QPA2286A is a high performance SiGe HBT MMIC Amplifier. A Darlington configuration provides high F_T and excellent thermal performance. The heterojunction increases breakdown voltage and minimizes leakage current between junctions. Cancellation of emitter junction non-linearities results in higher suppression of intermodulation products. Only two DC-blocking capacitors, a bias resistor, and an optional RF choke are required for operation.



4 Lead SOT-86 Package

Functional Block Diagram

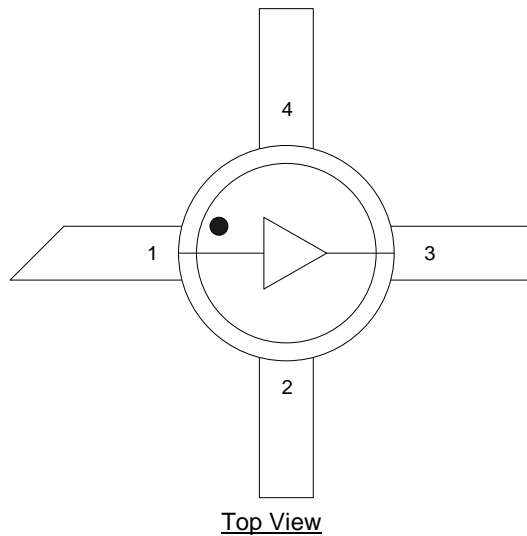

Product Features

- High Gain: 13.7 dB at 1950 MHz
- Cascadable 50 Ω
- Operates from Single Supply
- Low Thermal Resistance Package

Applications

- Instrumentation
- Repeaters
- Boosters
- PA Driver Amplifier
- Cellular, PCS, GSM, UMTS
- IF Amplifier
- Wireless Data, Satellite

Ordering Information

Part No.	Description
QPA2286ATR13	3000 pieces on a 13" reel (standard)
QPA2286ASQ	25 Piece Sample Bag
QPA2286ASR	100 Pieces on 7" Reel
QPA2286APCK401	850 MHz, +5V EVB with 5 Piece Sample Bag

Absolute Maximum Ratings

Parameter	Rating
Storage Temp	-55 to +150 °C
Device Voltage (V_D)	+4 V
Device Current (I_D)	40 mA
RF Input Power	+18 dBm

Exceeding any one or a combination of the Absolute Maximum Rating conditions may cause permanent damage to the device. Extended application of Absolute Maximum Rating conditions to the device may reduce device reliability.

Recommended Operating Conditions

Parameter	Min	Typ	Max	Units
Operating Temperature	-40		+105	°C
Junction Temperature (T_J)			+125	°C
Device Operating Voltage	+1.9	+2.2	+2.5	V

Electrical specifications are measured at specified test conditions. Specifications are not guaranteed over all recommended operating conditions.

Electrical Specifications

Parameter	Conditions	Min	Typ	Max	Units
Small Signal Gain	850 MHz		14.7		dB
	1950 MHz		13.7		dB
	2400 MHz		13.5		dB
Output Power at 1dB Compression	850 MHz		7.0		dBm
	1950 MHz		7.5		dBm
Output Third Intercept Point	850 MHz		20.8		dBm
	1950 MHz		21.5		dBm
Input Return Loss	1950 MHz		13.3		dB
Output Return Loss	1950 MHz		18.5		dB
Noise Figure	1950 MHz		4.1		dB
Device Operating Current			20		mA
Thermal Resistance, θ_{jc}			106		°C/W

Notes:

1. Test conditions unless otherwise noted: $V_S = +5V$, $I_D = 20\text{ mA Typ.}$, OIP3 Tone Spacing=1 MHz, P_{OUT} per tone = -10 dBm, $R_1 = 140\ \Omega$, 50 Ω system, Temp = +25 °C

Evaluation Board and Schematic – 850 MHz Application Circuit

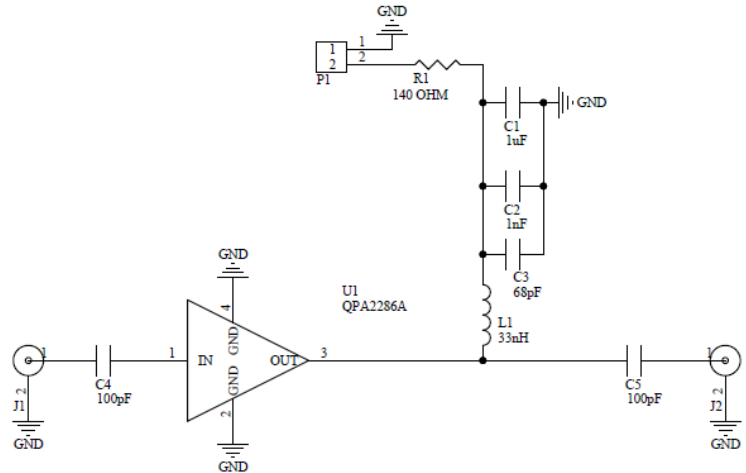
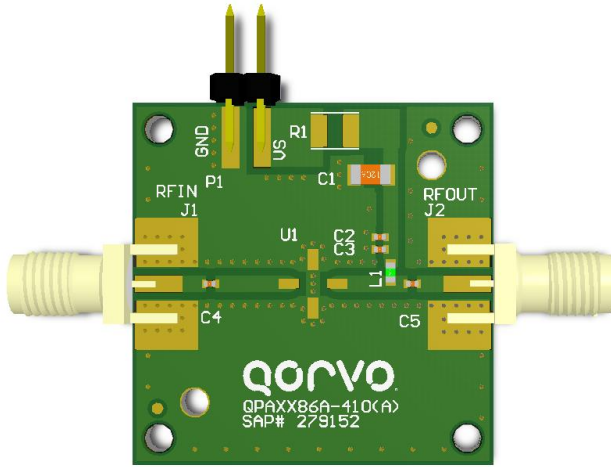

Bill of Material – 850 MHz Application Circuit

Reference	Value	Description	Manufacturer	Part Number
n/a	n/a	PCB, QPA2286A	Qorvo	QPAXX86A-410(A)
C1	1 uF	CAP, 10%, 25V, X7R, 1206	Murata Electronics	GRM31MR71E105KA01L
C2	1000 pF	CAP, 10%, 50V, X7R, 0402	Murata Electronics	GRM155R71H102KA01D
C3	68 pF	CAP, 5%, 50V, C0G, 0402	Murata Electronics	GRM1555C1H680JA01D
C4, C5	100 pF	CAP, 5%, 50V, C0G, 0402	Murata Electronics	GRM1555C1H101JA01D
R1	140 Ω	RES, 1%, 1/2W, 1210	Panasonic Industrial Co	ERJ-14NF1400U
L1	33 nH	IND, 5%, M/L, 0603	Murata Electronics	LL1608-FSL33NJ
J1, J2	n/a	CONN, SMA, EL, FLT, 0.068" SPE-000318	Amphenol RF Asia Corp	901-10426
U1	n/a	HBT MMIC Amplifier	Qorvo	QPA2286A
J3, J4	n/a	CONN, HDR, ST, 1x2, 0.100", Hi-temp, T/H	Samtec Inc	HTSW-102-07-G-S

Component Values for Specific Frequencies

Frequency	500 MHz	850 MHz	1950 MHz	2400 MHz	3500 MHz
C4, C5	220 pF	100 pF	68 pF	56 pF	39 pF
C3	100 pF	68 pF	22 pF	22 pF	15 pF
L1	68 nH	33 nH	22 nH	18 nH	15 nH

Recommended Bias Resistor Values for Various Supply Voltages

Vsupply	+5 V	+6 V	+8 V	+10 V
R1	140 Ω	200 Ω	300 Ω	390 Ω

Typical Performance – 850 MHz Application Circuit

Parameter	Typical Value					Units
Frequency	500	850	1950	2400	3500	MHz
Small Signal Gain	14.0	14.7	13.7	13.5	12.63	dB
Output Third Intercept Point	+19.7	+20.8	+21.5	+21.8	+20.4	dBm
Output Power at 1dB Compression	+6.4	+7.0	+7.5	+7.6	+7.4	dBm
Input Return Loss	19.3	20.9	13.3	12.7	11.0	dB
Output Return Loss	12.2	14.9	18.5	19.7	14.0	dB
Reverse Isolation	18.1	18.0	17.9	17.9	18.6	dB
Noise Figure	4.0	3.9	4.1	4.0	4.3	dB

Notes:

1. Test conditions: $V_s = +5V$, $I_D = 20\text{ mA Typ.}$, OIP3 Tone Spacing=1 MHz, P_{OUT} per tone = -10 dBm, $R_1 = 140\ \Omega$, 50 Ω system, Temp = +25 °C

Performance Plots – 850 MHz Application Circuit

Test conditions unless otherwise noted: $V_s = +5.0\text{ V}$, $I_D = 20\text{ mA}$, Temp.= +25 °C

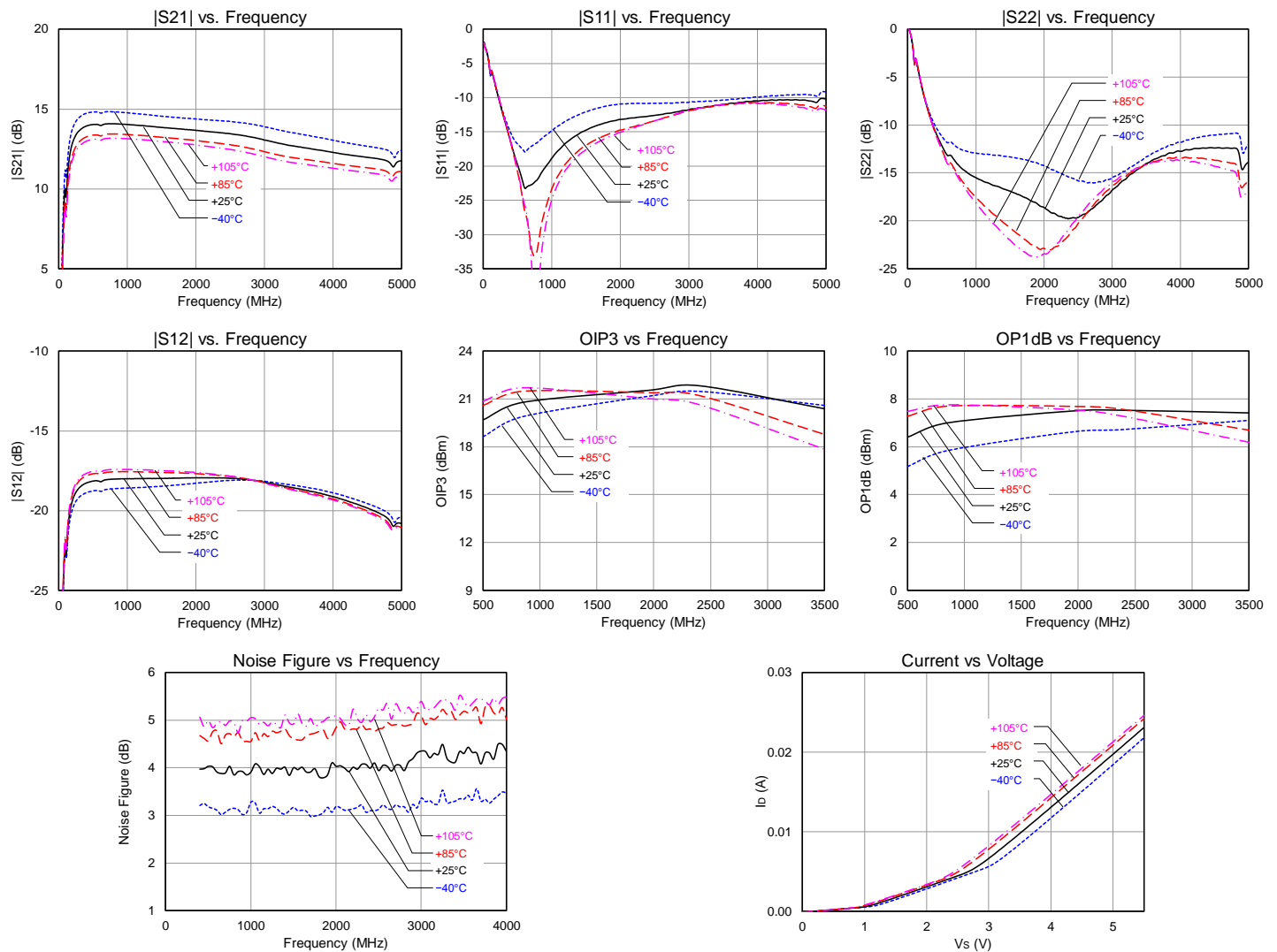

Pin Configuration and Description

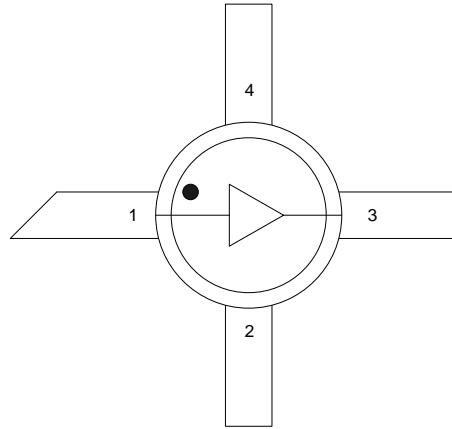

Top View

Pad No.	Label	Description
1	RF _{IN}	RF Input Pin. This pin requires the use of an external DC blocking capacitor chosen for the frequency of operation.
2, 4	GND	Connection to ground. Use via holes in PCB for best performance to reduce lead inductance as close to ground leads as possible
3	RF _{OUT}	RF Output and Bias Pin. DC voltage is present on this pin, therefore a DC blocking capacitor is necessary for proper operation.

Package Marking

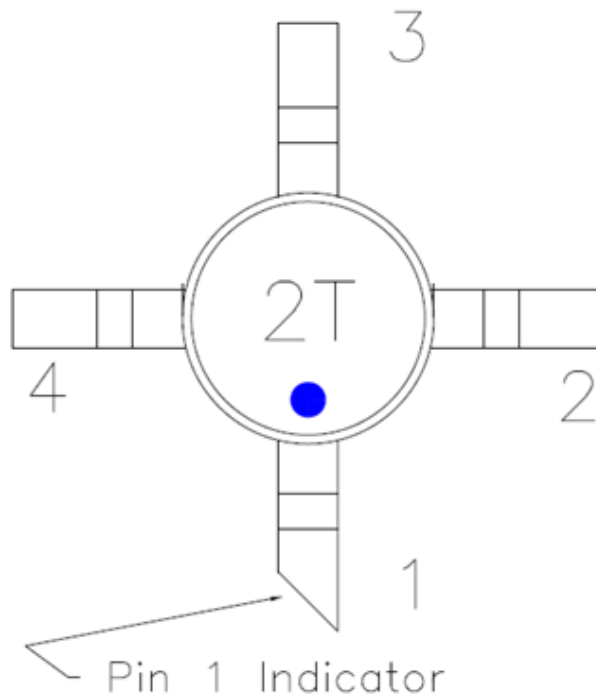

Package Dimensions

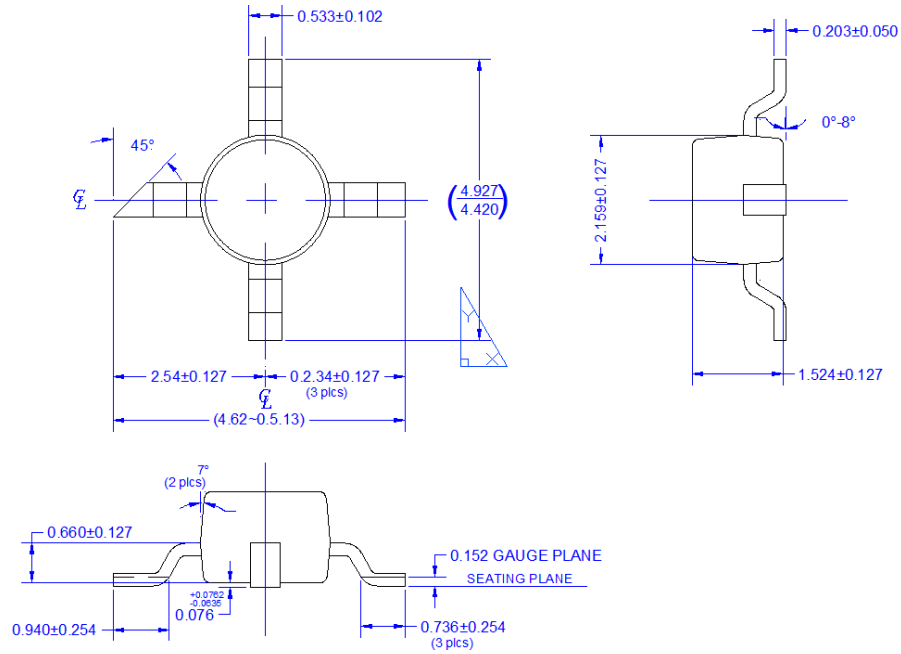

Notes:

- 1. All dimensions are in millimeters. Angles are in degrees.
- 2. Dimension and tolerance formats conform to ASME Y15.5-2009.

PCB Mounting Pattern

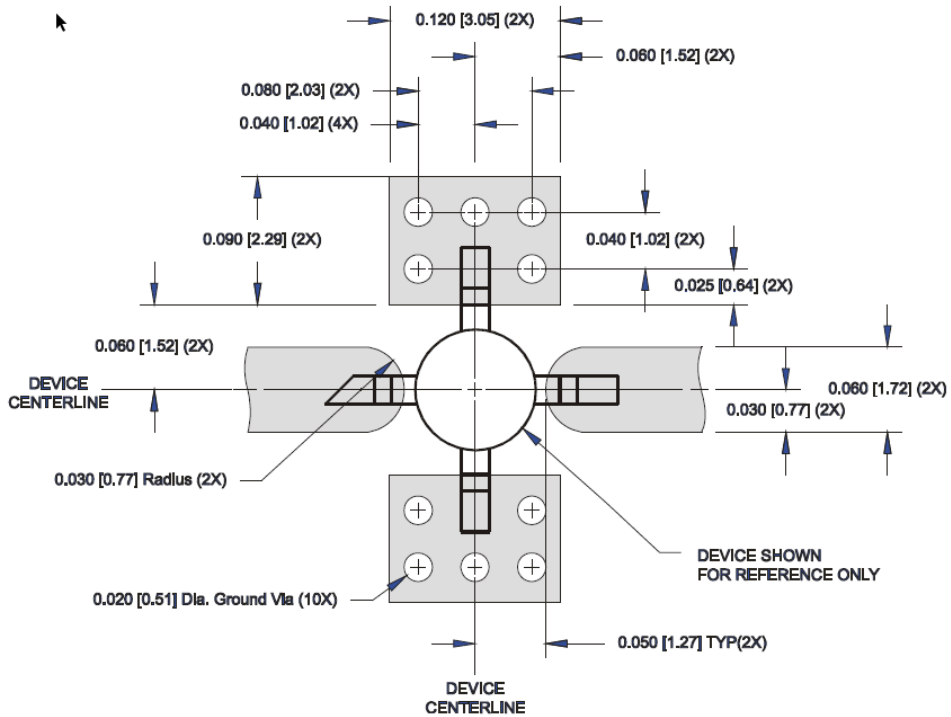

Notes:

- 1. All dimensions are in inches (millimeters). Angles are in degrees.

Handling Precautions

Parameter	Rating	Standard
ESD – Human Body Model (HBM)	Class 1C	ESDA / JEDEC JS-001-2014
ESD – Charged Device Model (CDM)	Class C3	ESDA / JEDEC JS-002-2014
MSL – Moisture Sensitivity Level	Level 1	IPC/JEDEC J-STD-020



Caution!
ESD-Sensitive Device

Solderability

Compatible with lead-free (260°C max. reflow temp.) soldering process.
Solder profiles available upon request.

Contact plating: Matte Sn

RoHS Compliance

This part is compliant with 2011/65/EU RoHS directive (Restrictions on the Use of Certain Hazardous Substances in Electrical and Electronic Equipment) as amended by Directive 2015/863/EU.

This product also has the following attributes:

- Lead Free
- Halogen Free (Chlorine, Bromine)
- Antimony Free
- TBBP-A (C₁₅H₁₂Br₄O₂) Free
- PFOS Free
- SVHC Free



Contact Information

For the latest specifications, additional product information, worldwide sales and distribution locations:

Web: www.qorvo.com

Tel: 1-844-890-8163

Email: customer.support@qorvo.com

For technical questions and application information: **Email:** sjcapplcations.engineering@qorvo.com

Important Notice

The information contained herein is believed to be reliable; however, Qorvo makes no warranties regarding the information contained herein and assumes no responsibility or liability whatsoever for the use of the information contained herein. All information contained herein is subject to change without notice. Customers should obtain and verify the latest relevant information before placing orders for Qorvo products. The information contained herein or any use of such information does not grant, explicitly or implicitly, to any party any patent rights, licenses, or any other intellectual property rights, whether with regard to such information itself or anything described by such information. **THIS INFORMATION DOES NOT CONSTITUTE A WARRANTY WITH RESPECT TO THE PRODUCTS DESCRIBED HEREIN, AND QORVO HEREBY DISCLAIMS ANY AND ALL WARRANTIES WITH RESPECT TO SUCH PRODUCTS WHETHER EXPRESS OR IMPLIED BY LAW, COURSE OF DEALING, COURSE OF PERFORMANCE, USAGE OF TRADE OR OTHERWISE, INCLUDING THE IMPLIED WARRANTIES OF MERCHANTABILITY AND FITNESS FOR A PARTICULAR PURPOSE.**

Without limiting the generality of the foregoing, Qorvo products are not warranted or authorized for use as critical components in medical, life-saving, or life-sustaining applications, or other applications where a failure would reasonably be expected to cause severe personal injury or death.

Copyright 2016 © Qorvo, Inc. | Qorvo is a registered trademark of Qorvo, Inc.



**Стандарт
Электрон
Связь**

Мы молодая и активно развивающаяся компания в области поставок электронных компонентов. Мы поставляем электронные компоненты отечественного и импортного производства напрямую от производителей и с крупнейших складов мира.

Благодаря сотрудничеству с мировыми поставщиками мы осуществляем комплексные и плановые поставки широчайшего спектра электронных компонентов.

Собственная эффективная логистика и склад в обеспечивает надежную поставку продукции в точно указанные сроки по всей России.

Мы осуществляем техническую поддержку нашим клиентам и предпродажную проверку качества продукции. На все поставляемые продукты мы предоставляем гарантию .

Осуществляем поставки продукции под контролем ВП МО РФ на предприятия военно-промышленного комплекса России , а также работаем в рамках 275 ФЗ с открытием отдельных счетов в уполномоченном банке. Система менеджмента качества компании соответствует требованиям ГОСТ ISO 9001.

Минимальные сроки поставки, гибкие цены, неограниченный ассортимент и индивидуальный подход к клиентам являются основой для выстраивания долгосрочного и эффективного сотрудничества с предприятиями радиоэлектронной промышленности, предприятиями ВПК и научно-исследовательскими институтами России.

С нами вы становитесь еще успешнее!

Наши контакты:

Телефон: +7 812 627 14 35

Электронная почта: sales@st-electron.ru

Адрес: 198099, Санкт-Петербург,
Промышленная ул, дом № 19, литера Н,
помещение 100-Н Офис 331