



## MAX98300 Evaluation Kit (WLP)

### General Description

The MAX98300 evaluation kit (EV kit) is a fully assembled and tested circuit board that uses the MAX98300 filterless Class D amplifier to drive a speaker in portable audio applications. The EV kit comes with a MAX98300 IC in a 9-bump, 0.4mm pitch wafer-level-package (WLP). Designed to operate from a 2.6V to 5.5V DC power supply, the EV kit is capable of delivering 2.6W into a 4Ω load. The EV kit accepts differential or single-ended input signals.

### Features

- ◆ Demonstrates Industry-Leading Quiescent Current
  - 1.1mA (PVDD = 5V), 0.78mA (PVDD = 3.7V)
- ◆ Filterless Operation Passes Radiated Emissions with Up to 60cm of Speaker Cable
- ◆ 2.6V to 5.5V Single-Supply Operation
- ◆ 2.6W Mono Class D Output
- ◆ Selectable Gain Control
- ◆ Differential or Single-Ended Input
- ◆ Low-Power Shutdown Input
- ◆ Fully Assembled and Tested

### Ordering Information

PART	TYPE
MAX98300EVKIT+WLP	EV Kit

+Denotes lead(Pb)-free and RoHS compliant.

### Component List

DESIGNATION	QTY	DESCRIPTION
<b>MINIMAL COMPONENTS FOR CUSTOMER DESIGN</b>		
C1	1	10μF ±20%, 6.3V X5R ceramic capacitor (0603) Murata GRM188R60J106M
C2	1	0.1μF ±10%, 16V X7R ceramic capacitor (0402) Murata GRM155R71C104K
C3, C4	2	1μF ±10%, 10V X5R ceramic capacitors (0402) Murata GRM155R61A105K
U1	1	Mono Class D amplifier (9 WLP) Maxim MAX98300EWL+ (Top Mark: +AIH)
<b>OPTIONAL COMPONENTS FOR CUSTOMER EVALUATION</b>		
C5, C6	0	Not installed, ceramic capacitors (0603)
C7-C11	5	0.22μF ±10%, 25V X7R ceramic capacitors (0603) Murata GRM188R71E224K

DESIGNATION	QTY	DESCRIPTION
FB1, FB2	2	0Ω ±5% resistors (0603)
JU1	1	2-pin header
JU2	1	3-pin header
JU3	1	4-way 5-pin header
L1, L2	0	Not installed, inductors Recommended: TOKO #A916CY-220M
OUT+	1	Standard PCB test point, red
OUT-	1	Standard PCB test point, white
R1, R2	2	100kΩ ±5% resistors (0402)
R3, R4	2	22Ω ±5% resistors (0603)
R5, R6	0	Not installed, resistors (0402)
—	3	Shunts (JU1, JU2, JU3)
—	1	PCB: MAX98300 EVALUATION KIT+ (WLP)

Evaluates: MAX98300 in a WLP

# MAX98300 Evaluation Kit (WLP)

## Component Suppliers

SUPPLIER	PHONE	WEBSITE
Murata Electronics North America, Inc.	770-436-1300	www.murata-northamerica.com
TOKO America, Inc.	847-297-0070	www.tokoam.com

**Note:** Indicate that you are using the MAX98300EWL+ when contacting these component suppliers.

## Quick Start

### Recommended Equipment

- MAX98300 EV kit
- 2.6V to 5.5V, 2A DC supply
- 4Ω speaker
- Mono audio signal source

### Procedure

The EV kit is fully assembled and tested. Follow the steps below to verify board operation.

**Caution: Do not turn on the power supply until all connections are completed.**

- 1) Verify that shunts are installed as follows:
  - JU1: Installed (single-ended input)
  - JU2: Pins 1-2 (device enabled)
  - JU3: Pins 1-5 (0dB gain)
- 2) Connect the power-supply positive and negative outputs to the PVDD and PGND PCB pads on the EV kit, respectively.
- 3) Verify that the audio source output is disabled.
- 4) Connect the mono audio source between the INPUT+ and INPUT- pads on the EV kit.
- 5) Connect the speaker across the OUT+ and OUT- test points.
- 6) Set the power-supply output to 5V.
- 7) Enable the power-supply output.
- 8) Enable the audio source.
- 9) Verify that the speaker is playing the audio source signal.

## Detailed Description of Hardware

The MAX98300 EV kit features the MAX98300 filterless Class D amplifier IC, which is designed to drive a mono speaker in portable audio applications. The EV kit comes with a MAX98300 IC in a 9-bump, 0.4mm pitch WLP. The EV kit operates from a DC power supply that provides 2.6V to 5.5V and 2A of current. The EV kit accepts a differential or single-ended audio input. The audio input source is amplified to drive 2.6W into a 4Ω speaker.

Jumper JU1 configures the EV kit inputs for single-ended or differential operation. Jumper JU2 enables or disables the speaker amplifier. The amplifier overall gain can be set between 0dB and +12dB using jumper JU3. The EV kit provides a set of differential outputs. The device outputs (OUT+, OUT-) can be connected directly to a speaker load without any filtering and up to 60cm of cable. However, filter components can be added to ease evaluation. See the *Output Filtering Options* section for additional information.

### Input Mode

Jumper JU1 provides the option to select between a differential or single-ended input mode for the EV kit. See Table 1 for jumper JU1 configuration.

**Table 1. Input Mode (JU1)**

SHUNT POSITION	INPUT- PCB PAD	INPUT MODE
Installed*	Connected to PGND	Single-ended input
Not installed	Connected to a user-supplied negative differential input	Differential input

\*Default position.

# MAX98300 Evaluation Kit (WLP)

Evaluates: MAX98300 in a WLP

## Shutdown

Jumper JU2 enables or disables the audio speaker amplifier. See Table 2 for jumper JU2 configuration.

## Gain Setting

The EV kit maximum signal gain can be configured to five different settings. Jumper JU3 selects the overall gain for the EV kit. See Table 3 for jumper JU3 configuration.

## Filtered Output

Audio analyzers typically cannot accept pulse-width-modulated (PWM) signals at their inputs. Therefore, the EV kit features a lowpass filter at its outputs to ease evaluation. Install inductors L1 and L2 (provided with the EV kit) and use the filtering output posts (FOUT+ and FOUT-) to connect the filtered PWM outputs to the audio analyzer. The default lowpass filter at the EV kit outputs is optimized for an 8Ω speaker.

## Filterless Output

The EV kit's filterless outputs (OUT+ and OUT-) can be connected directly to a speaker load without any filtering. Use the OUT+ and OUT- test points to connect a speaker directly to the MAX98300 outputs. Inductors L1 and L2 are not installed for maximum efficiency.

## Output Filtering Options

To ease evaluation, the EV kit is shipped with inductor-based output filters. To use the inductor-based output filters, install inductors L1 and L2 (provided with the EV kit).

The IC passes CE EN55022B regulations with up to 60cm of speaker cable and no filtering. However, ferrite-bead filters can be used to achieve further attenuation of radiated emissions. To install the ferrite-bead filters, verify that filter inductors L1 and L2 are not installed. Next, replace shorting resistors FB1 and FB2 with 0603 or smaller ferrite beads and install filter capacitors on the C5 and C6 pads. The speaker wire should be connected to the OUT+ and OUT- test points.

Table 2. Shutdown (JU2)

SHUNT POSITION	SHDN PIN	AMPLIFIER
1-2*	Connected to PVDD	Enabled
2-3	Connected to PGND	Disabled

\*Default position.

Table 3. Gain Setting (JU3)

SHUNT POSITION	GAIN PIN	MAXIMUM GAIN (dB)
1-2	Connected to PVDD through R1	+9
1-3	Connected to PVDD	+12
1-4	Connected to PGND through R2	+3
1-5*	Connected to PGND	0
Open	Not connected	+6

\*Default position.

# MAX98300 Evaluation Kit (WLP)

Evaluates: MAX98300 in a WLP

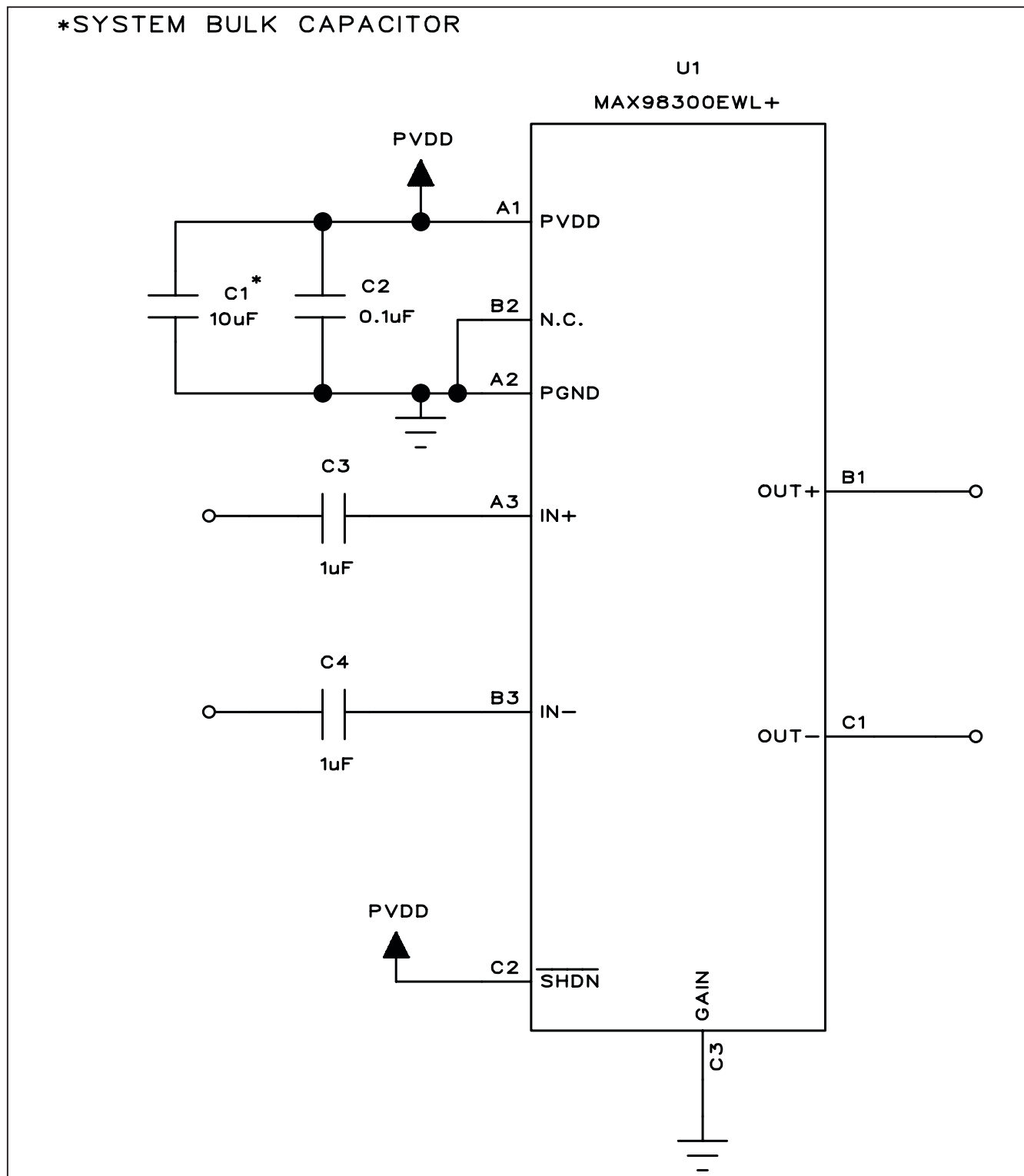

Figure 1. MAX98300 Customer Design Schematic (WLP)

# MAX98300 Evaluation Kit (WLP)

Evaluates: MAX98300 in a WLP

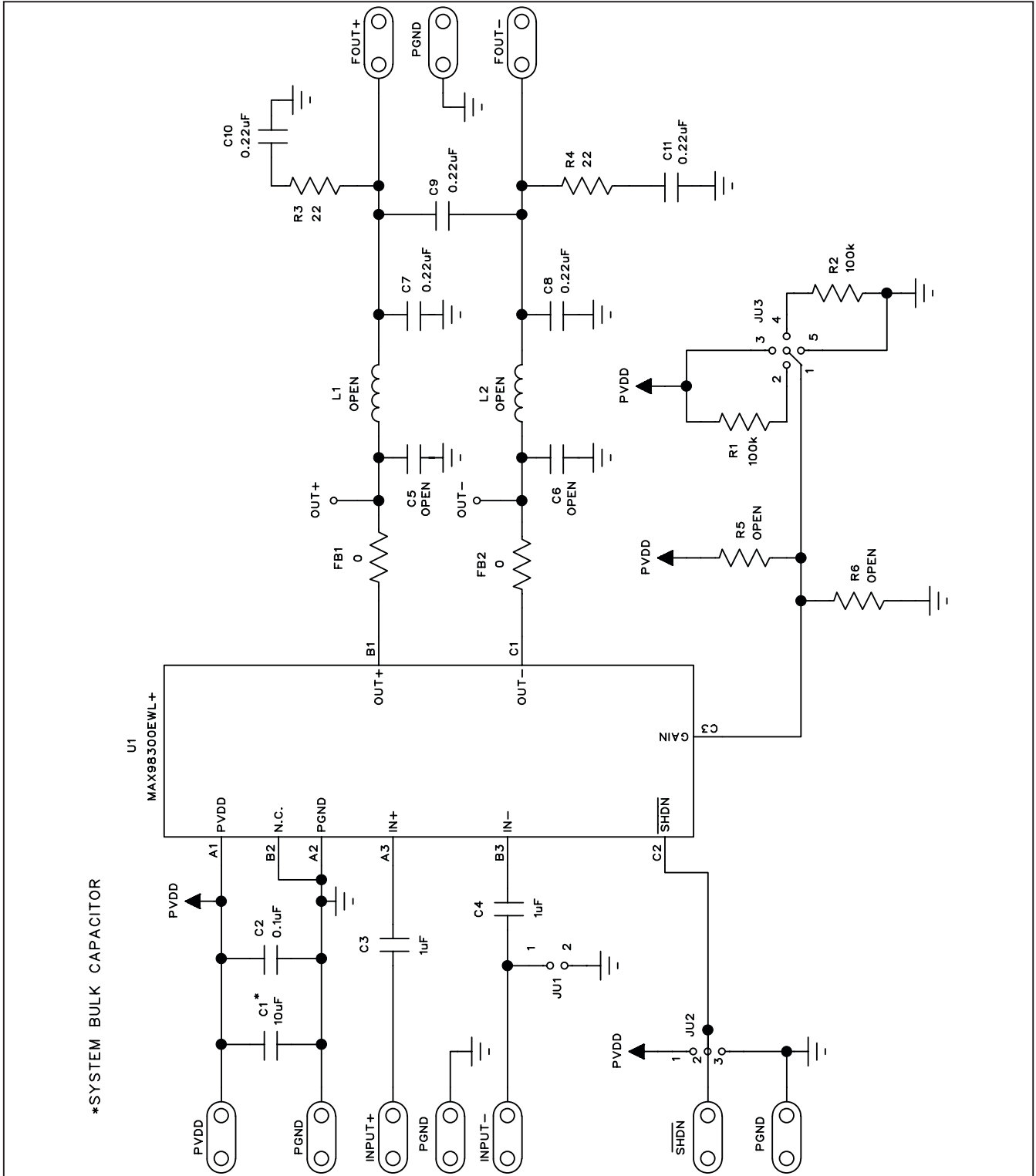

Figure 2. MAX98300 EV Kit Schematic (WLP)

# MAX98300 Evaluation Kit (WLP)

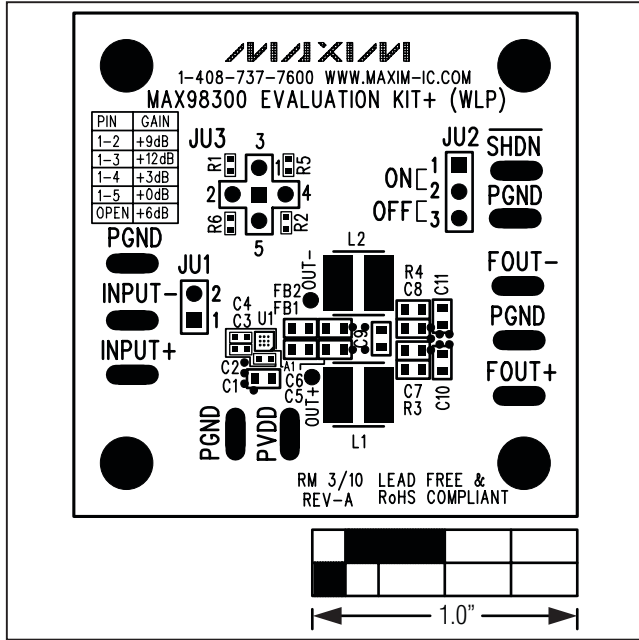

Figure 3. MAX98300 EV Kit (WLP) Component Placement Guide—Component Side

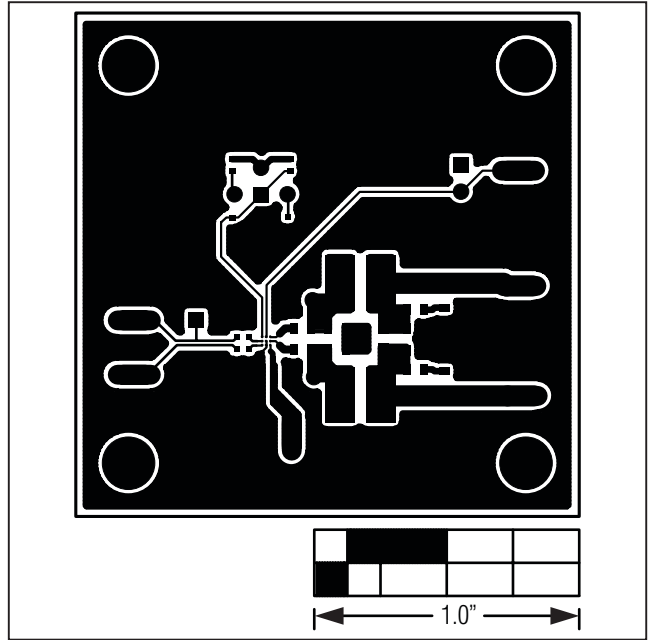

Figure 4. MAX98300 EV Kit (WLP) PCB Layout—Component Side

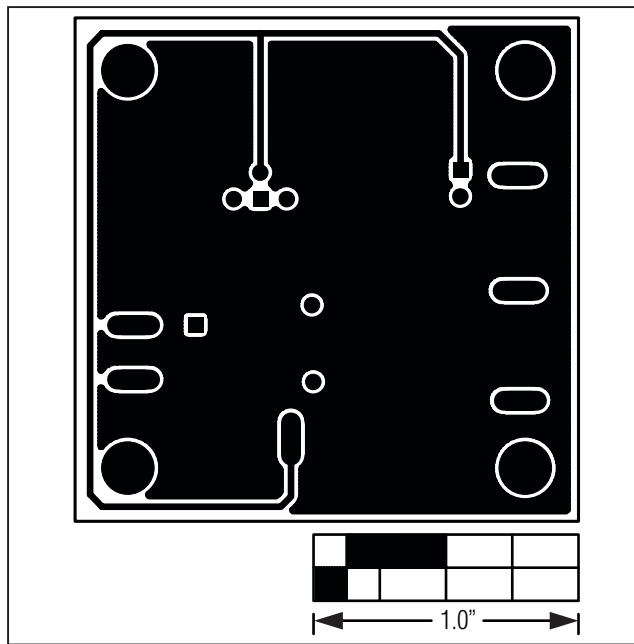

Figure 5. MAX98300 EV Kit (WLP) PCB Layout—Solder Side

# MAX98300 Evaluation Kit (WLP)

## Revision History

REVISION NUMBER	REVISION DATE	DESCRIPTION	PAGES CHANGED
0	5/10	Initial release	—

**Evaluates: MAX98300 in a WLP**

*Maxim cannot assume responsibility for use of any circuitry other than circuitry entirely embodied in a Maxim product. No circuit patent licenses are implied. Maxim reserves the right to change the circuitry and specifications without notice at any time.*

**Maxim Integrated Products, 120 San Gabriel Drive, Sunnyvale, CA 94086 408-737-7600 \_\_\_\_\_ 7**



## Стандарт Электрон Связь

Мы молодая и активно развивающаяся компания в области поставок электронных компонентов. Мы поставляем электронные компоненты отечественного и импортного производства напрямую от производителей и с крупнейших складов мира.

Благодаря сотрудничеству с мировыми поставщиками мы осуществляем комплексные и плановые поставки широчайшего спектра электронных компонентов.

Собственная эффективная логистика и склад в обеспечивает надежную поставку продукции в точно указанные сроки по всей России.

Мы осуществляем техническую поддержку нашим клиентам и предпродажную проверку качества продукции. На все поставляемые продукты мы предоставляем гарантию .

Осуществляем поставки продукции под контролем ВП МО РФ на предприятия военно-промышленного комплекса России , а также работаем в рамках 275 ФЗ с открытием отдельных счетов в уполномоченном банке. Система менеджмента качества компании соответствует требованиям ГОСТ ISO 9001.

Минимальные сроки поставки, гибкие цены, неограниченный ассортимент и индивидуальный подход к клиентам являются основой для выстраивания долгосрочного и эффективного сотрудничества с предприятиями радиоэлектронной промышленности, предприятиями ВПК и научно-исследовательскими институтами России.

С нами вы становитесь еще успешнее!

### Наши контакты:

**Телефон:** +7 812 627 14 35

**Электронная почта:** [sales@st-electron.ru](mailto:sales@st-electron.ru)

**Адрес:** 198099, Санкт-Петербург,  
Промышленная ул, дом № 19, литера Н,  
помещение 100-Н Офис 331