

# EE-SX77/87

CSM\_EE-SX77\_87\_DS\_E\_7\_2

## Slim, Compact Photomicrosensor that is still easy to use.

- Compact, thin profile enables dense mounting.
- Indicator is visible from both sides.
- Wide operating voltage range: 5 to 24 VDC



For the most recent information on models that have been certified for safety standards, refer to your OMRON website.

Be sure to read *Safety Precautions* on page 4.

## Ordering Information

Pre-wired Models  Infrared light

Appearance	Sensing method	Cable length	Sensing distance		Output configuration	Indicator mode	Model					
							NPN output	PNP output				
Standard 	Through-beam type (with slot)	2 m	<input type="checkbox"/>	5 mm (slot width)	Dark-ON	Incident light	EE-SX770 2M	EE-SX770P 2M				
						No incident light	EE-SX770A 2M	EE-SX770R 2M				
Light-ON					Incident light	EE-SX870 2M	EE-SX870P 2M					
					No incident light	EE-SX870A 2M	EE-SX870R 2M					
L-shaped 					Through-beam type (with slot)	2 m	<input type="checkbox"/>	5 mm (slot width)	Dark-ON	Incident light	EE-SX771 2M	EE-SX771P 2M
										No incident light	EE-SX771A 2M	EE-SX771R 2M
Light-ON	Incident light	EE-SX871 2M	EE-SX871P 2M									
	No incident light	EE-SX871A 2M	EE-SX871R 2M									
T-shaped 	Through-beam type (with slot)	2 m	<input type="checkbox"/>	5 mm (slot width)					Dark-ON	Incident light	EE-SX772 2M	EE-SX772P 2M
										No incident light	EE-SX772A 2M	EE-SX772R 2M
					Light-ON	Incident light	EE-SX872 2M	EE-SX872P 2M				
						No incident light	EE-SX872A 2M	EE-SX872R 2M				

## Ratings and Specifications

Item	Type	Standard	L-shaped	T-shaped
		NPN models	EE-SX770/EE-SX870 EE-SX770A/EE-SX870A	EE-SX771/EE-SX871 EE-SX771A/EE-SX871A
	PNP models	EE-SX770P/EE-SX870P EE-SX770R/EE-SX870R	EE-SX771P/EE-SX871P EE-SX771R/EE-SX871R	EE-SX772P/EE-SX872P EE-SX772R/EE-SX872R
<b>Sensing distance</b>		5 mm (slot width)		
<b>Sensing object</b>		Opaque: 2 × 0.8 mm min.		
<b>Differential distance</b>		0.025 mm		
<b>Light source</b>		GaAs infrared LED with a peak wavelength of 940 nm		
<b>Indicator</b>		Light indicator (red) (turns ON when light is interrupted for models with A or R suffix)		
<b>Supply voltage</b>		5 to 24 VDC ±10%, ripple (p-p): 10% max.		
<b>Current consumption</b>		35 mA max. (NPN models), 30 mA max. (PNP models)		
<b>Control output</b>		NPN open collector: 5 to 24 VDC, 100 mA max. 100 mA load current with a residual voltage of 0.8 V max. 40 mA load current with a residual voltage of 0.4 V max. OFF current (leakage current): 0.5 mA max. PNP open collector: 5 to 24 VDC, 50 mA max. 50 mA load current with a residual voltage of 1.3 V max. OFF current (leakage current): 0.5 mA max.		
<b>Response frequency *</b>		1 kHz min. (3 kHz average)		
<b>Ambient illumination</b>		1,000 lx max. with fluorescent light on the surface of the receiver		
<b>Ambient temperature range</b>		Operating: -25 to +55°C Storage: -30 to +80°C (with no icing)		
<b>Ambient humidity range</b>		Operating: 5% to 85% Storage: 5% to 95% (with no condensation)		
<b>Vibration resistance</b>		Destruction: 20 to 2,000 Hz (peak acceleration: 100 m/s <sup>2</sup> ) 1.5-mm double amplitude for 2 h (4-min periods) each in X, Y, and Z directions		
<b>Shock resistance</b>		Destruction: 500 m/s <sup>2</sup> for 3 times each in X, Y, and Z directions		
<b>Degree of protection</b>		IEC60529 IP60		
<b>Connecting method</b>		Pre-wired (standard cable length: 2 m)		
<b>Weight (packaged)</b>		Approx. 20 g		
<b>Material</b>		Case: Polybutylene phthalate (PBT)		

\* The response frequency was measured by detecting the following rotating disk.



Engineering Data (Reference Value)

Sensing Position Characteristics

Sensing Position Characteristics

Repeated Sensing Position Characteristics

EE-SX770

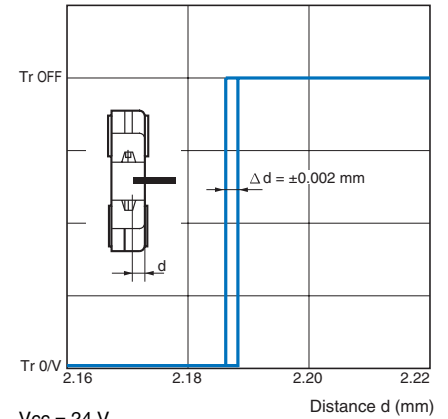

Vcc = 24 V  
 No. of repetitions: 20, Ta = 25°C  
 Note: The data applies to dark status. Operation may be affected by external light interference or light coming through the sensing object.

I/O Circuit Diagrams

NPN Output

Model	Output configuration	Timing charts	Output circuit
EE-SX770 EE-SX771 EE-SX772	Dark-ON	Incident Interrupted Light indicator (red) ON OFF Output transistor ON OFF Load (e.g., relay) Operates Releases	
EE-SX870 EE-SX871 EE-SX872	Light-ON	Incident Interrupted Light indicator (red) ON OFF Output transistor ON OFF Load (e.g., relay) Operates Releases	
EE-SX770A EE-SX771A EE-SX772A	Dark-ON	Incident Interrupted Light indicator (red) ON OFF Output transistor ON OFF Load (e.g., relay) Operates Releases	
EE-SX870A EE-SX871A EE-SX872A	Light-ON	Incident Interrupted Light indicator (red) ON OFF Output transistor ON OFF Load (e.g., relay) Operates Releases	

PNP Output

Model	Output configuration	Timing chart	Output circuit
EE-SX770P EE-SX771P EE-SX772P	Dark-ON		
EE-SX870P EE-SX871P EE-SX872P	Light-ON		
EE-SX770R EE-SX771R EE-SX772R	Dark-ON		
EE-SX870R EE-SX871R EE-SX872R	Light-ON		

Safety Precautions

Refer to *Warranty and Limitations of Liability*.

**WARNING**

This product is not designed or rated for ensuring safety of persons either directly or indirectly. Do not use it for such purposes.

**Precautions for Correct Use**

Make sure that this product is used within the rated ambient environment conditions.

## Dimensions

Tolerance class IT16 applies to dimensions in this datasheet unless otherwise specified.

### Standard

EE-SX770/770P  
 EE-SX870/870P  
 EE-SX770A/770R  
 EE-SX870A/870R



### L-shaped

EE-SX771/771P  
 EE-SX871/871P  
 EE-SX771A/771R  
 EE-SX871A/871R



### T-shaped

EE-SX772/772P  
 EE-SX872/872P  
 EE-SX772A/772R  
 EE-SX872A/872R



## Read and Understand This Catalog

Please read and understand this catalog before purchasing the products. Please consult your OMRON representative if you have any questions or comments.

## Warranty and Limitations of Liability

### WARRANTY

OMRON's exclusive warranty is that the products are free from defects in materials and workmanship for a period of one year (or other period if specified) from date of sale by OMRON.

OMRON MAKES NO WARRANTY OR REPRESENTATION, EXPRESS OR IMPLIED, REGARDING NON-INFRINGEMENT, MERCHANTABILITY, OR FITNESS FOR PARTICULAR PURPOSE OF THE PRODUCTS. ANY BUYER OR USER ACKNOWLEDGES THAT THE BUYER OR USER ALONE HAS DETERMINED THAT THE PRODUCTS WILL SUITABLY MEET THE REQUIREMENTS OF THEIR INTENDED USE. OMRON DISCLAIMS ALL OTHER WARRANTIES, EXPRESS OR IMPLIED.

### LIMITATIONS OF LIABILITY

OMRON SHALL NOT BE RESPONSIBLE FOR SPECIAL, INDIRECT, OR CONSEQUENTIAL DAMAGES, LOSS OF PROFITS OR COMMERCIAL LOSS IN ANY WAY CONNECTED WITH THE PRODUCTS, WHETHER SUCH CLAIM IS BASED ON CONTRACT, WARRANTY, NEGLIGENCE, OR STRICT LIABILITY.

In no event shall the responsibility of OMRON for any act exceed the individual price of the product on which liability is asserted.

IN NO EVENT SHALL OMRON BE RESPONSIBLE FOR WARRANTY, REPAIR, OR OTHER CLAIMS REGARDING THE PRODUCTS UNLESS OMRON'S ANALYSIS CONFIRMS THAT THE PRODUCTS WERE PROPERLY HANDLED, STORED, INSTALLED, AND MAINTAINED AND NOT SUBJECT TO CONTAMINATION, ABUSE, MISUSE, OR INAPPROPRIATE MODIFICATION OR REPAIR.

## Application Considerations

### SUITABILITY FOR USE

OMRON shall not be responsible for conformity with any standards, codes, or regulations that apply to the combination of products in the customer's application or use of the products.

At the customer's request, OMRON will provide applicable third party certification documents identifying ratings and limitations of use that apply to the products. This information by itself is not sufficient for a complete determination of the suitability of the products in combination with the end product, machine, system, or other application or use.

The following are some examples of applications for which particular attention must be given. This is not intended to be an exhaustive list of all possible uses of the products, nor is it intended to imply that the uses listed may be suitable for the products:

- Outdoor use, uses involving potential chemical contamination or electrical interference, or conditions or uses not described in this catalog.
- Nuclear energy control systems, combustion systems, railroad systems, aviation systems, medical equipment, amusement machines, vehicles, safety equipment, and installations subject to separate industry or government regulations.
- Systems, machines, and equipment that could present a risk to life or property.

Please know and observe all prohibitions of use applicable to the products.

NEVER USE THE PRODUCTS FOR AN APPLICATION INVOLVING SERIOUS RISK TO LIFE OR PROPERTY WITHOUT ENSURING THAT THE SYSTEM AS A WHOLE HAS BEEN DESIGNED TO ADDRESS THE RISKS, AND THAT THE OMRON PRODUCTS ARE PROPERLY RATED AND INSTALLED FOR THE INTENDED USE WITHIN THE OVERALL EQUIPMENT OR SYSTEM.

### PROGRAMMABLE PRODUCTS

OMRON shall not be responsible for the user's programming of a programmable product, or any consequence thereof.

## Disclaimers

### CHANGE IN SPECIFICATIONS

Product specifications and accessories may be changed at any time based on improvements and other reasons.

It is our practice to change model numbers when published ratings or features are changed, or when significant construction changes are made. However, some specifications of the products may be changed without any notice. When in doubt, special model numbers may be assigned to fix or establish key specifications for your application on your request. Please consult with your OMRON representative at any time to confirm actual specifications of purchased products.

### DIMENSIONS AND WEIGHTS

Dimensions and weights are nominal and are not to be used for manufacturing purposes, even when tolerances are shown.

### PERFORMANCE DATA

Performance data given in this catalog is provided as a guide for the user in determining suitability and does not constitute a warranty. It may represent the result of OMRON's test conditions, and the users must correlate it to actual application requirements. Actual performance is subject to the OMRON Warranty and Limitations of Liability.

### ERRORS AND OMISSIONS

The information in this document has been carefully checked and is believed to be accurate; however, no responsibility is assumed for clerical, typographical, or proofreading errors, or omissions.

2012.8

In the interest of product improvement, specifications are subject to change without notice.

**OMRON Corporation**  
Industrial Automation Company

<http://www.ia.omron.com/>

(c)Copyright OMRON Corporation 2012 All Right Reserved.



## Стандарт Электрон Связь

Мы молодая и активно развивающаяся компания в области поставок электронных компонентов. Мы поставляем электронные компоненты отечественного и импортного производства напрямую от производителей и с крупнейших складов мира.

Благодаря сотрудничеству с мировыми поставщиками мы осуществляем комплексные и плановые поставки широчайшего спектра электронных компонентов.

Собственная эффективная логистика и склад в обеспечивает надежную поставку продукции в точно указанные сроки по всей России.

Мы осуществляем техническую поддержку нашим клиентам и предпродажную проверку качества продукции. На все поставляемые продукты мы предоставляем гарантию .

Осуществляем поставки продукции под контролем ВП МО РФ на предприятия военно-промышленного комплекса России , а также работаем в рамках 275 ФЗ с открытием отдельных счетов в уполномоченном банке. Система менеджмента качества компании соответствует требованиям ГОСТ ISO 9001.

Минимальные сроки поставки, гибкие цены, неограниченный ассортимент и индивидуальный подход к клиентам являются основой для выстраивания долгосрочного и эффективного сотрудничества с предприятиями радиоэлектронной промышленности, предприятиями ВПК и научно-исследовательскими институтами России.

С нами вы становитесь еще успешнее!

### Наши контакты:

**Телефон:** +7 812 627 14 35

**Электронная почта:** [sales@st-electron.ru](mailto:sales@st-electron.ru)

**Адрес:** 198099, Санкт-Петербург,  
Промышленная ул, дом № 19, литера Н,  
помещение 100-Н Офис 331