

## LED Lamp Module

# A60 F0 type module



- **Maximum up to 7W**
- **CREE LEDs**
- **E26 and E27 lamp base**
- **UL plastic material**

The lamp base can be compatible to either E26 or E27 standard base.

The Heat dissipation of A60 F0 type module heat sink can be up to maximum 7 wattage.

A60 F0 type module uses UL listed material for all the plastic components.

A60 F0 type module will be the best solution for bulb lamp.

# ▶▶ Table of Contents

<b>Specifications .....</b>	<b>P. 3</b>
<b>Exterior Dimensions .....</b>	<b>P. 4</b>
<b>Nomenclature .....</b>	<b>P. 4</b>
<b>Part Number .....</b>	<b>P. 5</b>
<b>The circuit design reference .....</b>	<b>P. 6</b>
<b>Life Time .....</b>	<b>P. 6</b>
<b>Package information .....</b>	<b>P. 7 ~ P. 10</b>
<b>Reference information .....</b>	<b>P. 11 ~ P. 20</b>

# Specifications

Module Name	A60 F0 type module	
With the use of LED	 CXA1512	
Rating Power	Maximum up to 7 Wattage	
LED Quantity	1pcs	
LED Dispose Mode	1S	
Lens efficiency	80%	
Lamp holder	E26 type	E27 type
Exterior Dimension	60*112 mm	60*115mm
Beam Angle	270 deg.	
Operate Temperature	-20°C~+50°C	
Storage Temperature	-20°C~+50°C	

Table 1 : The specifications for A60 F0 type.

# ▶▶ Exterior Dimension

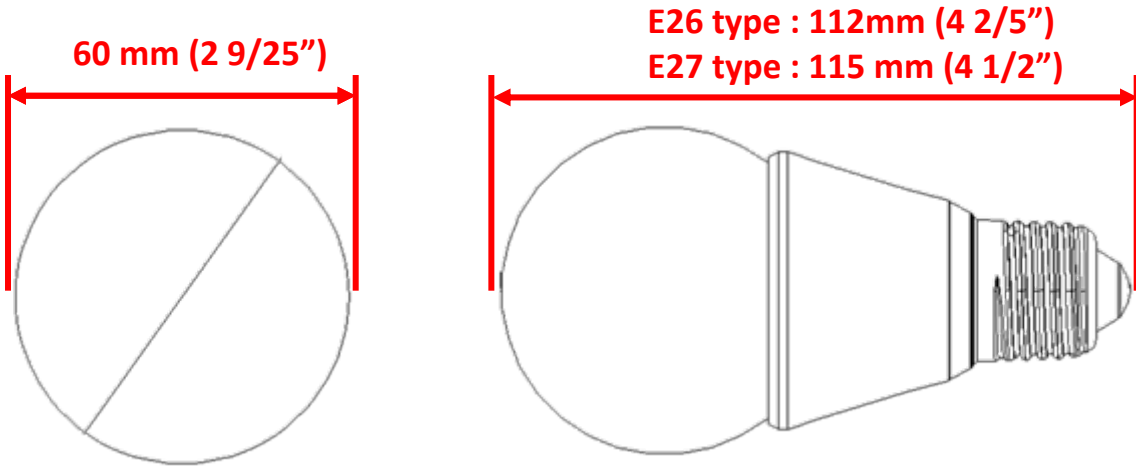

Tolerance : 2.5 mm (1/10")

Figure 1 : The exterior dimension for A60 F0 type module.

# ▶▶ Nomenclature

**M A60F0 B E27 – L B7 01 – BAG 00**

X1 X2 X3 X4 X5 X6 X7 X8 X9

**X1**

Company Code

M : Ledlink Module

**X2**

Product Series Type

A60F0 : A60F0 type

**X3**

Exterior Color

W : White  
B : Black

**X4**

Lamp Holder

E26 : E26 type  
E27 : E27 type

**X5**

Lens type

L : Lampshade

**X6**

Beam Angle

B7 : 270 degrees

**X7**

Lens Quantity

01: Single

**X8**

Lens Number

BAG: BAG model

**X9**

Package

00 : series number

Figure 2 : The nomenclature for A60 F0 type module.

# ▶▶ Part Number

Part Number	Lamp Holder	Heat sink Material	Plastic Material	Plastic Color	Cover color
MA60F0BE26-LB701-BAG00	E26 type	ADC 12 + Anodized	UL approval Plastic*	Black	
MA60F0WE26-LB701-BAG00				White	
MA60F0BE27-LB701-BAG00	E27 type			Black	
MA60F0WE27-LB701-BAG00				White	

\* : Please refer to "reference information" in page 11 ~ 15.

Table 2 : The part number for A60 F0 type.

## ▶▶ The circuit design reference

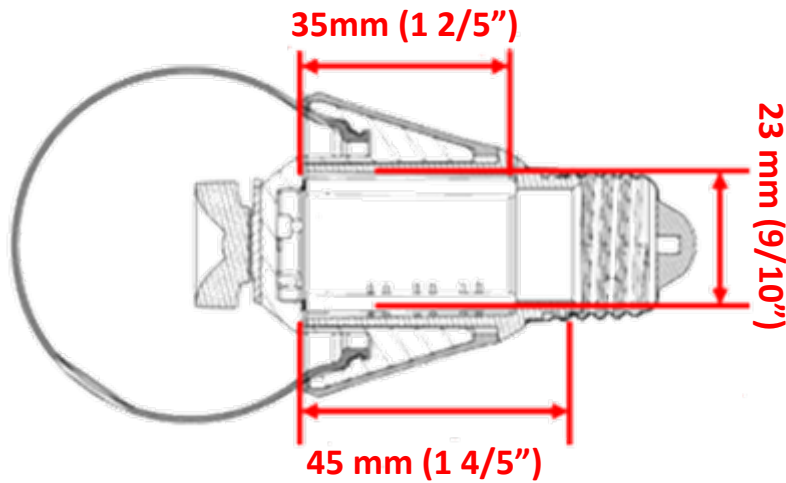

Figure 3 : The maximum size of the circuit area for A60 F0 type module.

Notification : A60 F0 type module doesn't include the circuit part

## ▶▶ Life Time

Lighting Output

Ambient temperature

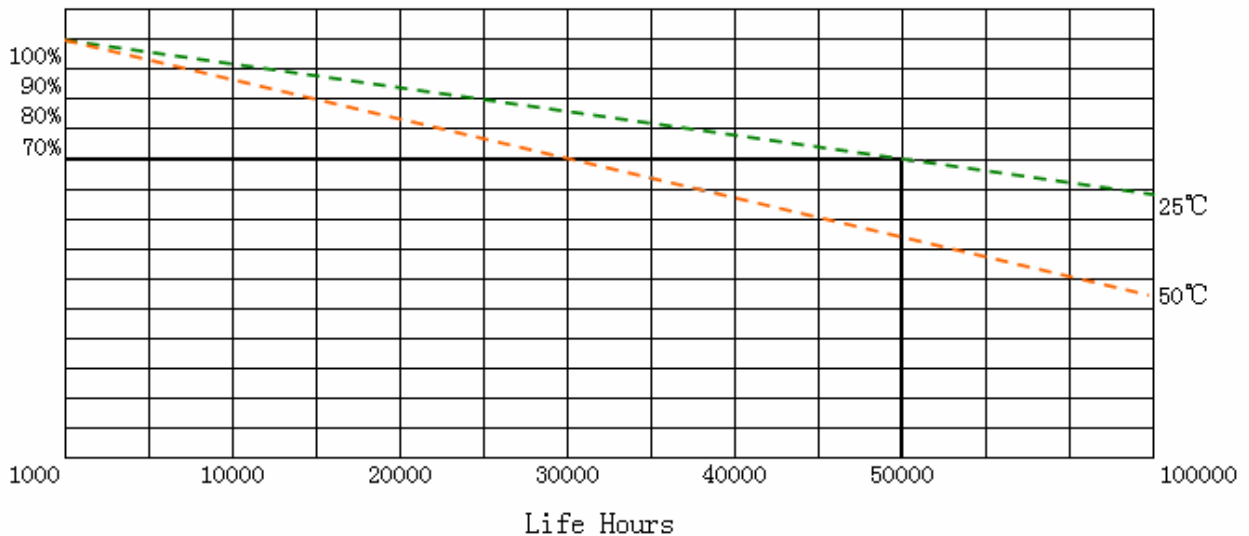

Figure 4: Lighting Output & Life Hours

# Package information

## Lamp shade part :



← Lamp shade

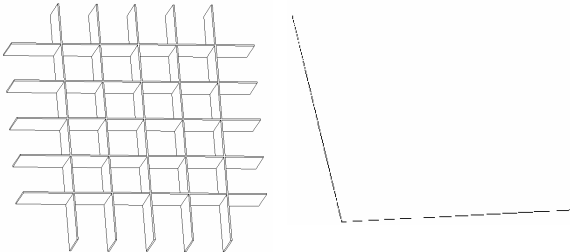

← Put Mode:  
 $1\text{PCS} \times 36 = 36\text{pcs}$

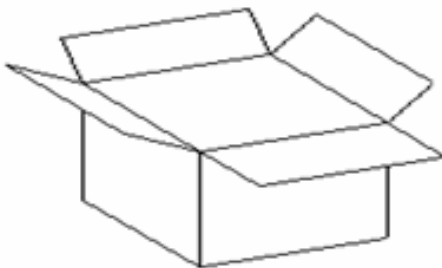

← Inner Box:  
 $36\text{PCS} \times 6 = 216\text{pcs}$

Figure 5: The package information for Lamp shade part.

# Package information

Lens part :

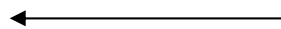

Lens

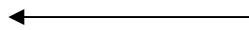
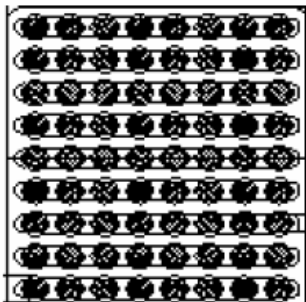

Put Mode:  
 $8\text{PCS} \times 9 = 72\text{pcs}$

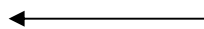
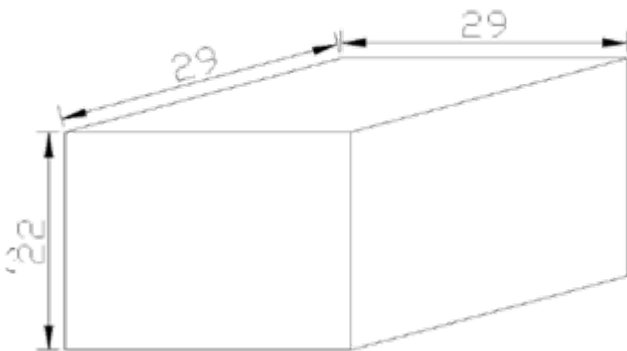

Inner Box:  
 $72\text{PCS} \times 12 = 864\text{pcs}$

Figure 5: The package information for Lens part.



# Package information

Heat sink part :

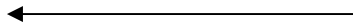

Heat sink

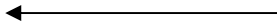
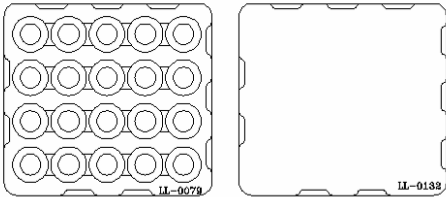

Put Mode:  
20pcs

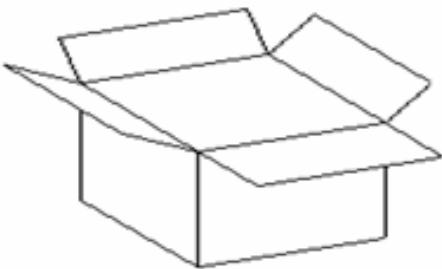

Inner Box:  
 $20 \times 3 = 60$ pcs

Figure 6 : The package information for heat sink part.

# Package information

## Lamp base part :



← Lamp Base

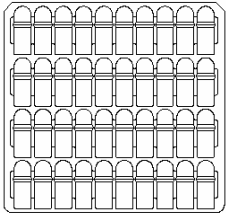

← Put Mode:  
 $1 * 40 = 40 \text{ pcs}$

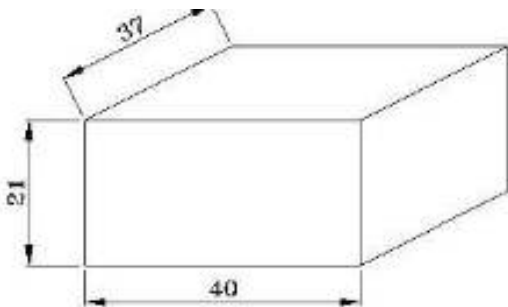

← Inner Box:  
 $40 * 6 \text{ Tier} = 240 \text{ pcs}$

Figure 7 : The package information for lamp base part..

# ▶▶ Reference information

## The UL card of UL plastic material :

Component - Plastics							E135714
<b>NYTEX COMPOSITES CO LTD</b>							
6 LANE 468 CHANGSUI RD, SEC 4, PEITOU HSIANG CHANGHUA HSIEN 523 TW							
<b>CM-5000</b>							
Polyamide 66/6 (PA66/6), blend, mineral fiber, flame retardant, furnished as pellets							
	<b>Min Thk</b>	<b>Flame</b>			<b>RTI</b>	<b>RTI</b>	<b>RTI</b>
<b>Color</b>	<b>(mm)</b>	<b>Class</b>	<b>HWI</b>	<b>HAI</b>	<b>Elec</b>	<b>Imp</b>	<b>Str</b>
BK	1.6	V-0	2	1	65	65	65
	3.2	V-0	1	1	65	65	65
Comparative Tracking Index (CTI): -				Inclined Plane Tracking (IPT): -			
Dielectric Strength (kV/mm): -				Volume Resistivity (10 <sup>14</sup> ohm-cm): -			
High-Voltage Arc Tracking Rate (HVTR): -				High Volt, Low Current Arc Resis (D495): -			
Dimensional Stability (%): -							
ANSI/UL 94 small-scale test data does not pertain to building materials, furnishings and related contents. ANSI/UL 94 small-scale test data is intended solely for determining the flammability of plastic materials used in the components and parts of end-product devices and appliances, where the acceptability of the combination is determined by UL.							
Report Date: 2013-03-19							
Last Revised: 2013-03-19							
© 2013 UL LLC							
							
<b>IEC and ISO Test Methods</b>							
<b>Test Name</b>	<b>Test Method</b>	<b>Units</b>	<b>Thickness</b>	<b>Tested (mm)</b>	<b>Value</b>		
Flammability	IEC 60695-11-10	Class (color)	1.6		V-0 (BK)		
			3.2		V-0 (BK)		
Glow-Wire Flammability (GWFI)	IEC 60695-2-12	C	-		-		
Glow-Wire Ignition (GWIT)	IEC 60695-2-13	C	-		-		
IEC Comparative Tracking Index	IEC 60112	Volts (Max)	-		-		
IEC Ball Pressure	IEC 60695-10-2	C	-		-		
ISO Heat Deflection (1.80 MPa)	ISO 75-2	C	-		-		
ISO Tensile Strength	ISO 527-2	MPa	-		-		
ISO Flexural Strength	ISO 178	MPa	-		-		
ISO Tensile Impact	ISO 8256	kJ/m <sup>2</sup>	-		-		
ISO Izod Impact	ISO 180	kJ/m <sup>2</sup>	-		-		
ISO Charpy Impact	ISO 179-2	kJ/m <sup>2</sup>	-		-		
© 2013 UL LLC							

Figure8 : The UL card information of the sink part.

# Reference information

## The UL card of UL plastic material :

Component - Plastics							E206114
<b>STYRON (HONG KONG) LTD</b>							
TSING YI R & D LABORATORY, 40-50 TSING YI RD, TSING YI ISLAND N T HK							
<b>EMERGE PC 8130-(i)(f1)</b>							
Polycarbonate (PC), "EMERGE", furnished as pellets							
<b>Color</b>	<b>Min Thk (mm)</b>	<b>Flame Class</b>	<b>HWI</b>	<b>HAI</b>	<b>RTI Elec</b>	<b>RTI Imp</b>	<b>RTI Str</b>
ALL	1.5 3.0	V-0 V-0,5VA	2 2	1 1	130 130	115 115	130 130
Comparative Tracking Index (CTI): 2				Inclined Plane Tracking (IPT): -			
Dielectric Strength (kV/mm): -				Volume Resistivity (10 <sup>x</sup> ohm-cm) : -			
High-Voltage Arc Tracking Rate (HVTR): 1				High Volt, Low Current Arc Resis (D495): 7			
Dimensional Stability (%): -							
<b>(f1) - Suitable for outdoor use with respect to exposure to Ultraviolet Light, Water Exposure and Immersion in accordance with UL 746C.</b>							
<b>(i) - Followed by suffix numbers 3-15 incl. indicating melt flow rate</b>							
ANSI/UL 94 small-scale test data does not pertain to building materials, furnishings and related contents. ANSI/UL 94 small-scale test data is intended solely for determining the flammability of plastic materials used in the components and parts of end-product devices and appliances, where the acceptability of the combination is determined by UL.							
Report Date: 2011-07-12							
Last Revised: 2013-08-30				© 2014 UL LLC			
<b>IEC and ISO Test Methods</b>							
<b>Test Name</b>	<b>Test Method</b>	<b>Units</b>	<b>Thickness Tested (mm)</b>	<b>Value</b>			
<b>Flammability</b>	IEC 60695-11-10, IEC 60695-11-20	Class (color)	1.5 3.0	V-0 (ALL) V-0,5VA (ALL)			
Glow-Wire Flammability (GWF1)	IEC 60695-2-12	C	-	-			
Glow-Wire Ignition (GWIT)	IEC 60695-2-13	C	-	-			
IEC Comparative Tracking Index	IEC 60112	Volts (Max)	-	-			
IEC Ball Pressure	IEC 60695-10-2	C	3.0	137			
ISO Heat Deflection (1.80 MPa)	ISO 75-2	C	-	-			
ISO Tensile Strength	ISO 527-2	MPa	-	-			
ISO Flexural Strength	ISO 178	MPa	-	-			
ISO Tensile Impact	ISO 8256	kJ/m <sup>2</sup>	-	-			
ISO Izod Impact	ISO 180	kJ/m <sup>2</sup>	-	-			
ISO Charpy Impact	ISO 179-2	kJ/m <sup>2</sup>	-	-			
				© 2014 UL LLC			

Figure 9 : The UL card information of the Lamp shade part.

# Reference information

## The UL card of UL plastic material :

Component - Plastics							E48268
<b>IDEMITSU KOSAN CO LTD</b> BASIC CHEMICALS DEPT, 1-1 ANESAKI-KAIGAN, ICHIHARA-SHI CHIBA-KEN 299-0193 JP							
<b>LEV1700</b>							
Polycarbonate (PC), furnished as pellets							
Color	Min Thk (mm)	Flame Class	HWI	HAI	RTI Elec	RTI Imp	RTI Str
NC	0.42-1.9	V-2	-	-	80	80	80
Comparative Tracking Index (CTI): -				Dimensional Stability (%): -			
High-Voltage Arc Tracking Rate (HVTR): -				High Volt, Low Current Arc Resis (D495): -			
Dielectric Strength (kV/mm): -				Volume Resistivity (10 <sup>8</sup> ohm-cm) : -			
<small>ANSI/UL 94 small-scale test data does not pertain to building materials, furnishings and related contents. ANSI/UL 94 small-scale test data is intended solely for determining the flammability of plastic materials used in the components and parts of end-product devices and appliances, where the acceptability of the combination is determined by UL.</small>							
Report Date: 2010-04-06		Underwriters Laboratories Inc®					
Last Revised: 2010-04-06							
<b>IEC and ISO Test Methods</b>							
Test Name	Test Method	Units	Thickness Tested (mm)	Value			
Flammability	IEC 60695-11-10	Class (color)	0.42-1.9	V-2 (NC)			
Glow-Wire Flammability (GWFI)	IEC 60695-2-12	C	-	-			
Glow-Wire Ignition (GWIT)	IEC 60695-2-13	C	-	-			
IEC Comparative Tracking Index	IEC 60112	Volts (Max)	-	-			
IEC Ball Pressure	IEC 60695-10-2	C	-	-			
ISO Heat Deflection (1.80 MPa)	ISO 75-2	C	-	-			
ISO Tensile Strength	ISO 527-2	MPa	-	-			
ISO Flexural Strength	ISO 178	MPa	-	-			
ISO Tensile Impact	ISO 8256	kJ/m <sup>2</sup>	-	-			
ISO Izod Impact	ISO 180	kJ/m <sup>2</sup>	-	-			
ISO Charpy Impact	ISO 179-2	kJ/m <sup>2</sup>	-	-			
Underwriters Laboratories Inc®							

Figure 10 : The UL card information of the lens part.

# ▶▶ Reference information

## The UL card of UL plastic material :

Component - Plastics					E48268		
<b>IDEMITSU KOSAN CO LTD</b>							
1-1 MARUNOUCHI 3-CHOME, CHIYODA-KU, TOKYO 100-0005 JP							
<b>URC2500</b>							
Polycarbonate (PC), furnished as pellets							
	<b>Min Thk</b>	<b>Flame</b>			<b>RTI</b>	<b>RTI</b>	<b>RTI</b>
<b>Color</b>	<b>(mm)</b>	<b>Class</b>	<b>HWI</b>	<b>HAI</b>	<b>Elec</b>	<b>Imp</b>	<b>Str</b>
<b>WT</b>	<b>1.5</b>	<b>V-0</b>	-	-	<b>80</b>	<b>80</b>	<b>80</b>
	<b>3.0</b>	<b>V-0</b>	-	-	<b>80</b>	<b>80</b>	<b>80</b>
Comparative Tracking Index (CTI): -					Dimensional Stability (%): -		
High-Voltage Arc Tracking Rate (HVTR): -					High Volt, Low Current Arc Resis (D495): -		
Dielectric Strength (kV/mm): -					Volume Resistivity (10 <sup>X</sup> ohm-cm): -		
<small>UL94 small-scale test data does not pertain to building materials, furnishings and related contents. UL94 small-scale test data is intended solely for determining the flammability of plastic materials used in the components and parts of end-product devices and appliances, where the acceptability of the combination is determined by ULI.</small>							
Report Date: 2006-09-18		Underwriters Laboratories Inc®					
Last Revised: 2006-09-18							
<b>IEC and ISO Test Methods</b>							
<b>Test Name</b>	<b>Test Method</b>	<b>Units</b>	<b>Thickness Tested (mm)</b>	<b>Value</b>			
IEC Flammability	IEC 60695-11-10	Class (color)	1.5	V-0 (WT)			
			3.0	V-0 (WT)			
Glow-Wire Flammability (GWFI)	IEC 60695-2-12	C	-	-			
Glow-Wire Ignition (GWIT)	IEC 60695-2-13	C	-	-			
IEC Comparative Tracking Index	IEC 60112	Volts (Max)	-	-			
IEC Ball Pressure	IEC 60695-10-2	C	-	-			
ISO Heat Deflection (1.80 MPa)	ISO 75-2	C	-	-			
ISO Tensile Strength	ISO 527-2	MPa	-	-			
ISO Flexural Strength	ISO 178	MPa	-	-			
ISO Tensile Impact	ISO 8256	kJ/m <sup>2</sup>	-	-			
ISO Izod Impact	ISO 180	kJ/m <sup>2</sup>	-	-			
ISO Charpy Impact	ISO 179-2	kJ/m <sup>2</sup>	-	-			
Underwriters Laboratories Inc®							

Figure 11 : The UL card information of the lamp base part.(White )

# Reference information

The UL card of UL plastic material :



Component - Plastics								E-18268
<b>IDEMITSU KOSAN CO LTD</b>								
1-1 MARUNOUCHI 3-CHOME, CHIYODA-KU, TOKYO 100-0005 JP								
<b>LE1700</b>								
Polycarbonate (PC), furnished as pellets								
<b>Color</b>	<b>Min Thk (mm)</b>	<b>Flame Class</b>	<b>HWI</b>	<b>HAI</b>	<b>RTI Elec</b>	<b>RTI Imp</b>	<b>RTI Str</b>	
NC	0.45-0.50	V-2	-	-	80	80	80	
	1.5	-	3	3	80	80	80	
Comparative Tracking Index (CTI): -				Inclined Plane Tracking (IPT): -				
Dielectric Strength (kV/mm): -				Volume Resistivity (10 <sup>x</sup> ohm-cm): -				
High-Voltage Arc Tracking Rate (HVTR): -				High Volt, Low Current Arc Resis (D495): -				
Dimensional Stability (%): -								
ANSI/UL 94 small-scale test data does not pertain to building materials, furnishings and related contents. ANSI/UL 94 small-scale test data is intended solely for determining the flammability of plastic materials used in the components and parts of end-product devices and appliances, where the acceptability of the combination is determined by UL.								
Report Date: 2000-03-31		© 2012 UL LLC						
Last Revised: 2009-03-30								
<b>IEC and ISO Test Methods</b>								
<b>Test Name</b>	<b>Test Method</b>	<b>Units</b>	<b>Thickness Tested (mm)</b>	<b>Value</b>				
Flammability	IEC 60695-11-10	Class (color)	0.45-0.50	V-2 (IIC)				
			1.5	- (IIC)				
Glow-Wire Flammability (GWFI)	IEC 60695-2-12	C	-	-				
Glow-Wire Ignition (GWIT)	IEC 60695-2-13	C	-	-				
IEC Comparative Tracking Index	IEC 60112	Volts (Max)	-	-				
IEC Ball Pressure	IEC 60695-10-2	C	-	-				
ISO Heat Deflection (1.80 MPa)	ISO 75-2	C	-	-				
ISO Tensile Strength	ISO 527-2	MPa	-	-				
ISO Flexural Strength	ISO 178	MPa	-	-				
ISO Tensile Impact	ISO 8256	kJ/m <sup>2</sup>	-	-				
ISO Izod Impact	ISO 180	kJ/m <sup>2</sup>	-	-				
ISO Charpy Impact	ISO 179-2	kJ/m <sup>2</sup>	-	-				
© 2012 UL LLC								

Figure 12 : The UL card information of the lamp base part.(Black)

# ▶▶ Reference information

## The SGS card of SGS plastic material :



**Test Report**                      No. CANEC1319750803                      Date: 26 Dec 2013                      Page 1 of 5

DONGGUANCITY DAHONG PIASTIC PRODUCTS FACTORY  
INDUSTRIAL DISTRICT, SHANGTONG VILLAGE QISHITOWN

The following sample(s) was/were submitted and identified on behalf of the clients as : POWDER BLACK

SGS Job No. : CP13-065023 - GZ

Client Ref. Info. : K401, K402, K402A, K403, K404, K417, K418, B2014, B2014A, B2014C, B2014E, B2014P, B2015, B8008, B8008-A, B8007, B8011, B8011A, B8012, B8015, B859, C90584 Mixture

Date of Sample Received : 17 Dec 2013

Testing Period : 17 Dec 2013 - 23 Dec 2013

Test Requested : Selected test(s) as requested by client.

Test Method : Please refer to next page(s).

Test Results : Please refer to next page(s).

Conclusion : Based on the performed tests on submitted samples, the results of Lead, Mercury, Cadmium, Hexavalent chromium, Polybrominated biphenyls (PBB), Polybrominated diphenyl ethers (PBDE) comply with the limits as set by RoHS Directive 2011/65/EU Annex II; recasting 2002/95/EC.

Signed for and on behalf of  
SGS-CSTC Ltd.

Merry

Merry Lv  
Approved Signatory

This document is issued by the Company subject to its General Conditions of Service printed overleaf, available on request or accessible at <http://www.sgs.com/en/Terms-and-Conditions.aspx> and, for electronic format documents, subject to Terms and Conditions for Electronic Documents at <http://www.sgs.com/en/Terms-and-Conditions/Terms-and-Conditions.aspx>. The Company's findings at the time of its intervention only and within the limits of Client's instructions, if any. The Company's sole responsibility is to its Client and this document does not exonerate parties to a transaction from exercising all their rights and obligations under the transaction documents. This document cannot be reproduced except in full, without prior written approval of the Company. Any unauthorized alteration, forgery or falsification of the content or appearance of this document is unlawful and offenders may be prosecuted to the fullest extent of the law. Unless otherwise stated the results shown in this test report refer only to the sample(s) tested.



 SGS Customer Technical Services, Ltd.    中国·广州·经济技术开发区科学城科城路199号    邮编: 510663    电话: (86-20) 82135555    传真: (86-20) 82075113    www.sgs.com.cn  
 SGS Customer Technical Services, Ltd.    中国·广州·经济技术开发区科学城科城路199号    邮编: 510663    电话: (86-20) 82135555    传真: (86-20) 82075113    + sgschina@sgs.com

Figure 13 : The SGS card information of the lamp base part.(Black)



# ▶▶ Reference information

## The SGS card of SGS plastic material :



**Test Report**                      No. CANEC1319750803                      Date: 26 Dec 2013                      Page 2 of 5

Test Results :

Test Part Description :

Specimen No.	SGS Sample ID	Description
SN1	CAN13-197508.003	Black powder

Remarks :

- (1) 1 mg/kg = 1 ppm = 0.0001%
- (2) MDL = Method Detection Limit
- (3) ND = Not Detected ( < MDL )
- (4) "-" = Not Regulated

RoHS Directive 2011/65/EU

Test Method : (1)With reference to IEC 62321-5:2013, determination of Cadmium by ICP-OES.  
 (2)With reference to IEC 62321-5:2013, determination of Lead by ICP-OES.  
 (3)With reference to IEC 62321-4:2013, determination of Mercury by ICP-OES.  
 (4)With reference to IEC 62321:2008, determination of Hexavalent Chromium by Colorimetric Method using UV-Vis.  
 (5)With reference to IEC 62321:2008, determination of PBBs and PBDEs by GC-MS.

Test Item(s)	Limit	Unit	MDL	/03
Cadmium (Cd)	100	mg/kg	2	ND
Lead (Pb)	1,000	mg/kg	2	ND
Mercury (Hg)	1,000	mg/kg	2	ND
Hexavalent Chromium (CrVI)	1,000	mg/kg	2	ND
Sum of PBBs	1,000	mg/kg	-	ND
Monobromobiphenyl	-	mg/kg	5	ND
Dibromobiphenyl	-	mg/kg	5	ND
Tribromobiphenyl	-	mg/kg	5	ND
Tetrabromobiphenyl	-	mg/kg	5	ND
Pentabromobiphenyl	-	mg/kg	5	ND
Hexabromobiphenyl	-	mg/kg	5	ND
Heptabromobiphenyl	-	mg/kg	5	ND
Octabromobiphenyl	-	mg/kg	5	ND
Nonabromobiphenyl	-	mg/kg	5	ND
Decabromobiphenyl	-	mg/kg	5	ND
Sum of PBDEs	1,000	mg/kg	-	ND
Monobromodiphenyl ether	-	mg/kg	5	ND

This document is issued by the Company subject to its General Conditions of Service printed overleaf, available on request or accessible at <http://www.sgs.com/en/Terms-etc-Conditions.aspx> and for electronic format documents, subject to Terms and Conditions for Electronic Documents at <http://www.sgs.com/en/Terms-and-Conditions/Terms-etc-Conditions.aspx>. The Company's findings are based on the information contained in the documents submitted to the Company's findings at the time of its intervention only and within the limits of Client's instructions, if any. The Company's sole responsibility is to its Client and this document does not exonerate parties to a transaction from exercising all their rights and obligations under the transaction documents. This document cannot be reproduced or transmitted in any form or by any means, electronic or mechanical, including photocopying, recording, or by any information storage and retrieval system, without the prior written approval of the Company. Any unauthorized alteration, forgery or falsification of the content or appearance of this document is strictly prohibited and offenders may be prosecuted to the fullest extent of the law. Unless otherwise stated the results shown in this test report refer only to the sample(s) tested.



SGS-CTE (Shanghai) Technical Service Co., Ltd.  
 Shanghai Free Trade Zone, China

SGS-CTE (Shanghai) Technical Service Co., Ltd.  
 中国·广州·经济技术开发区科学城科珠路198号

TEL: 86-21-51066333    1 (86-21) 52155555    1 (86-21) 52175113    www.sgs.com.cn  
 86-21-51066333    1 (86-21) 52155555    1 (86-21) 52175113    # sgschina@sgs.com

Member of the RFLS Group (RFLS S&S)

Figure 14 : The SGS card information of the lamp base part.(Black)

# ▶▶ Reference information

The SGS card of SGS plastic material :



**Test Report**
No. CANEC1319750803
Date: 26 Dec 2013
Page 3 of 5

Test Item(s)	Limit	Unit	MDL	003
Dibromodiphenyl ether	-	mg/kg	5	ND
Tribromodiphenyl ether	-	mg/kg	5	ND
Tetrabromodiphenyl ether	-	mg/kg	5	ND
Pentabromodiphenyl ether	-	mg/kg	5	ND
Hexabromodiphenyl ether	-	mg/kg	5	ND
Heptabromodiphenyl ether	-	mg/kg	5	ND
Octabromodiphenyl ether	-	mg/kg	5	ND
Nonabromodiphenyl ether	-	mg/kg	5	ND
Decabromodiphenyl ether	-	mg/kg	5	ND

Notes :

(1) The maximum permissible limit is quoted from the directive 2011/65/EU, Annex II

This document is issued by the Company subject to its General Conditions of Service printed overleaf, available on request or accessible at <http://www.sgs.com/en/Terms-and-Conditions.aspx> and for electronic format documents, subject to Terms and Conditions for Electronic Documents at <http://www.sgs.com/en/Terms-and-Conditions/Terms-and-Conditions.aspx>. Sole responsibility is drawn to the limitation of liability, indemnification and jurisdiction issues defined therein. Any holder of this document is advised that information contained herein reflects the Company's findings at the time of its intervention only and within the limits of Client's instructions, if any. The Company's sole responsibility is to its Client and this document does not exonerate parties to a transaction from exercising all their rights and obligations under the transaction documents. This document cannot be reproduced except in full, without prior written approval of the Company. Any unauthorized alteration, forgery or falsification of the content or appearance of this document is unlawful and offenders may be prosecuted to the fullest extent of the law. Unless otherwise stated the results shown in this test report refer only to the sample(s) tested.



SGS-Service Technical Services, Ltd.  
Guangzhou, China

18 Kaili Road, Jiefang Park, Guangzhou Economic & Technological Development Zone, Guangzhou, China 510663 | (86-20) 82155555 | (86-20) 82175113 | www.sgs.com.cn  
 中国·广州·经济技术开发区科学城科珠路190号 邮编: 510663 | (86-20) 82155555 | (86-20) 82175113 | sgschina@sgs.com

Member of the SGS Group (SGS SA)

Figure 15 : The SGS card information of the lamp base part.(Black)

# Reference information

The SGS card of SGS plastic material :

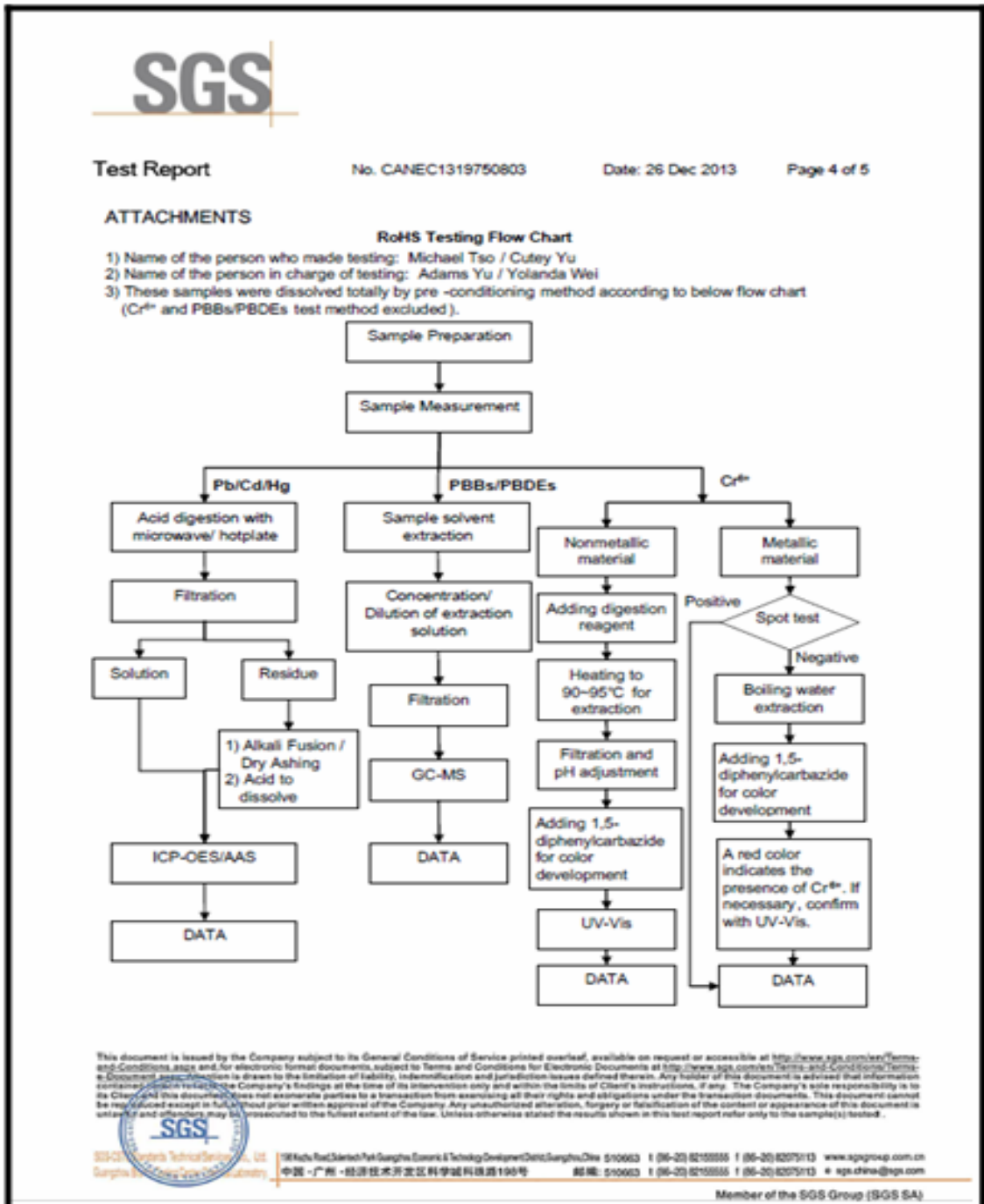

Figure 16 : The SGS card information of the lamp base part.(Black)

# ▶▶ Reference information

The SGS card of SGS plastic material :



Figure 17: The SGS card information of the lamp base part.(Black)



## Стандарт Электрон Связь

Мы молодая и активно развивающаяся компания в области поставок электронных компонентов. Мы поставляем электронные компоненты отечественного и импортного производства напрямую от производителей и с крупнейших складов мира.

Благодаря сотрудничеству с мировыми поставщиками мы осуществляем комплексные и плановые поставки широчайшего спектра электронных компонентов.

Собственная эффективная логистика и склад в обеспечивает надежную поставку продукции в точно указанные сроки по всей России.

Мы осуществляем техническую поддержку нашим клиентам и предпродажную проверку качества продукции. На все поставляемые продукты мы предоставляем гарантию .

Осуществляем поставки продукции под контролем ВП МО РФ на предприятия военно-промышленного комплекса России , а также работаем в рамках 275 ФЗ с открытием отдельных счетов в уполномоченном банке. Система менеджмента качества компании соответствует требованиям ГОСТ ISO 9001.

Минимальные сроки поставки, гибкие цены, неограниченный ассортимент и индивидуальный подход к клиентам являются основой для выстраивания долгосрочного и эффективного сотрудничества с предприятиями радиоэлектронной промышленности, предприятиями ВПК и научно-исследовательскими институтами России.

С нами вы становитесь еще успешнее!

### Наши контакты:

**Телефон:** +7 812 627 14 35

**Электронная почта:** [sales@st-electron.ru](mailto:sales@st-electron.ru)

**Адрес:** 198099, Санкт-Петербург,  
Промышленная ул, дом № 19, литера Н,  
помещение 100-Н Офис 331