



L6506 L6506D

CURRENT CONTROLLER FOR STEPPING MOTORS

DESCRIPTION

The L6506/D is a linear integrated circuit designed to sense and control the current in stepping motors and similar devices. When used in conjunction with the L293, L298, L7150, L6114/L6115, the chip set forms a constant current drive for an inductive load and performs all the interface function from the control logic thru the power stage.

Two or more devices may be synchronized using the sync pin. In this mode of operation the oscillator in the master chip sets the operating frequency in all chips.

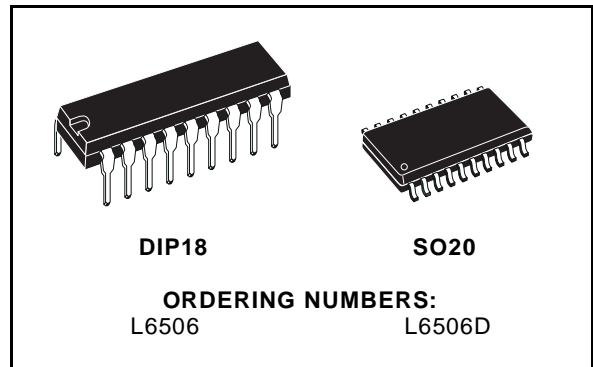

BLOCK DIAGRAM (pin's number referred to DIP-18)

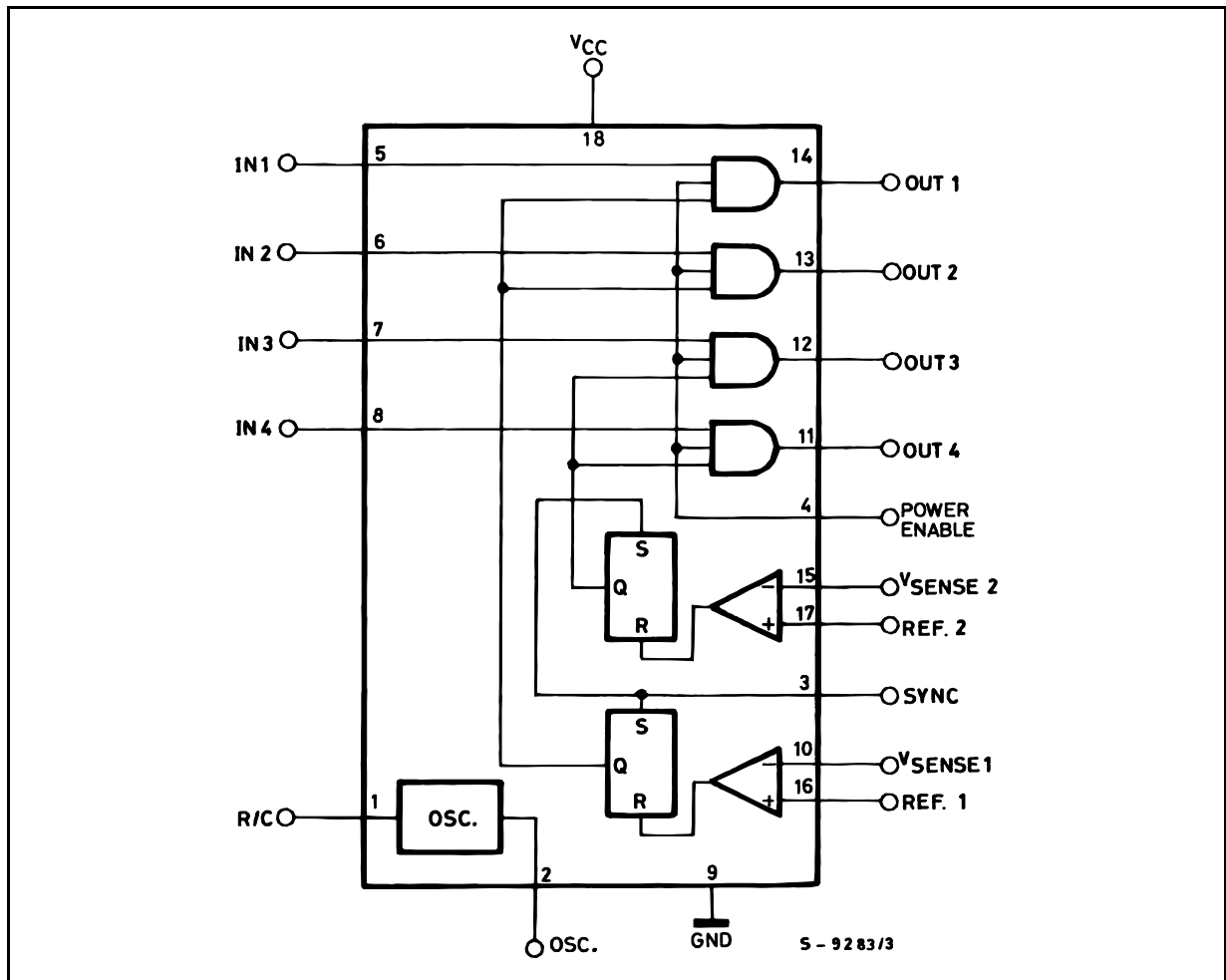

L6506 -L6506D

PIN CONNECTIONS (top view)

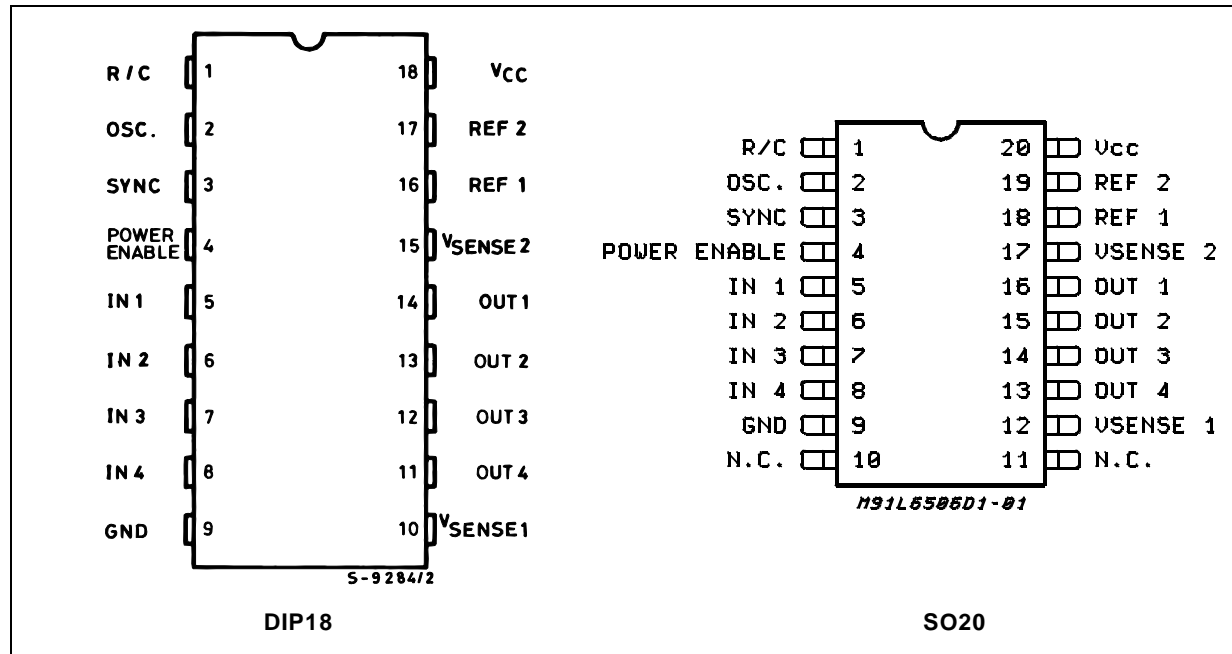

ABSOLUTE MAXIMUM RATINGS

Symbol	Parameter	Value	Unit
V _{CC}	Supply Voltage	10	V
V _i	Input Signals	7	V
P _{tot}	Total Power Dissipation (T _{amb} = 70°C) for DIP18 for SO20	1 0.8	W W
T _j	Junction Temperature	150	°C
T _{stg}	Storage Temperature	-40 to 150	°C

THERMAL DATA

Symbol	Parameter	DIP18	SO20	Unit
R _{thj-amb}	Thermal Resistance Junction-ambient Max.	80	100	°C/W

ELECTRICAL CHARACTERISTICS (V_{CC} = 5.0V, T_{amb} = 25°C; unless otherwise noted)

Symbol	Parameter	Test Conditions	Min.	Typ.	Max.	Unit
V _{CC}	Supply Voltage		4.5		7	V
I _{CC}	Quiescent Supply Current	V _{CC} = 7V			25	mA

COMPARATOR SECTION

Symbol	Parameter	Test Conditions	Min.	Typ.	Max.	Unit
V _{IN}	Input Voltage Range	V _{sense} Inputs	-0.3		3	V
V _{IO}	Input Offset Voltage	V _{IN} = 1.4V			±5.0	mV
I _{IO}	Input Offset Current				±200	nA
I _{IB}	Input Bias Current				1	µA
	Response time	V _{REF} = 1.4V V _{SENS} = 0 to 5V		0.8	1.5	µs

ELECTRICAL CHARACTERISTICS (continued)**COMPARATOR SECTION PERFORMANCE** (Over Operating Temperature Range)

Symbol	Parameter	Test Conditions	Min.	Typ.	Max.	Unit
V _{IO}	Input Offset Voltage	V _{IN} = 1.4V			±20	mV
I _{IO}	Input Offset Current				±500	nA

LOGIC SECTION (Over Operating Temperature Range - TTL compatible inputs & outputs)

Symbol	Parameter	Test Conditions	Min.	Typ.	Max.	Unit
V _{IH}	Input High Voltage		2		V _s	V
V _{IL}	Input Low Voltage				0.8	V
V _{OH}	Output High Voltage	V _{CC} = 4.75V I _{OH} = 400µA	2	3.5		V
V _{OL}	Output Low Voltage	V _{CC} = 4.75V I _{OH} = 4mA		0.25	0.4	V
I _{OH}	Output Source Current - Outputs 1 - 4	V _{CC} = 4.75V	2.75			mA

OSCILLATOR

Symbol	Parameter	Test Conditions	Min.	Typ.	Max.	Unit
f _{osc}	Frequency Range		5		70	KHz
V _{thL}	Lower Threshold Voltage			0.33 V _{CC}		V
V _{thH}	Higher Threshold Voltage			0.66 V _{CC}		V
R _i	Internal Discharge Resistor		0.7	1	1.3	kΩ

CIRCUIT OPERATION

The L6506 is intended for use with dual bridge drivers, such as the L298, quad darlington arrays, such as the L7150, quad DMOS array such as L6114-L6115, or discrete power transistors to drive stepper motors and other similar loads. The main function of the device is to sense and control the current in each of the load windings.

A common on-chip oscillator drives the dual chopper and sets the operating frequency for the pulse width modulated drive. The RC network on pin 1 sets the operating frequency which is given by the equation :

$$f = \frac{1}{0.69 RC} \text{ for } R > 10 K$$

The oscillator provides pulses to set the two flip-flops which in turn cause the outputs to activate the drive. When the current in the load winding reaches the programmed peak value, the voltage across the sense resistor (R_{sense}) is equal to V_{ref} and the corresponding comparator resets its flip-flop interrupting the drive current until the next oscillator pulse occurs. The peak current in each winding is programmed by selecting the value of the sense resistor

and V_{ref}. Since separate inputs are provided for each chopper, each of the loads may be programmed independently allowing the device to be used to implement microstepping of the motor. Lower threshold of L6506's oscillator is 1/3 V_{CC}. Upper threshold is 2/3 V_{CC} and internal discharge resistor is 1 kΩ ± 30 %.

Ground noise problems in multiple configurations can be avoided by synchronizing the oscillators. This may be done by connecting the sync pins of each of the devices with the oscillator output of the master device and connecting the R/C pin of the unused oscillators to ground.

The equations for the active time of the sync pulse (T₂), the inactive time of the sync signal (T₁) and the duty cycle can be found by looking at the figure 1 and are :

$$T_2 = 0.69 C_1 \frac{R_1 R_{IN}}{R_1 + R_{IN}} \quad (1)$$

$$T_1 = 0.69 R_1 C_1 \quad (2)$$

$$DC = \frac{T_2}{T_1 + T_2} \quad (3)$$

By substituting equations 1 and 2 into equation 3 and solving for the value of R1 the following equations for the external components can be derived :

$$R1 = \left(\frac{1}{DC} - 2 \right) R_{IN} \quad (4)$$

$$C1 = \frac{T1}{0.69 R1} \quad (5)$$

Looking at equation 1 it can easily be seen that the minimum pulse width of T2 will occur when the value of R1 is at its minimum and the value of R1 at its maximum. Therefore, when evaluating equation 4 the minimum value for R1 of 700Ω (1 KΩ – 30 %) should be used to guarantee the required pulse width.

Figure 1 : Oscillator Circuit and Waveforms.

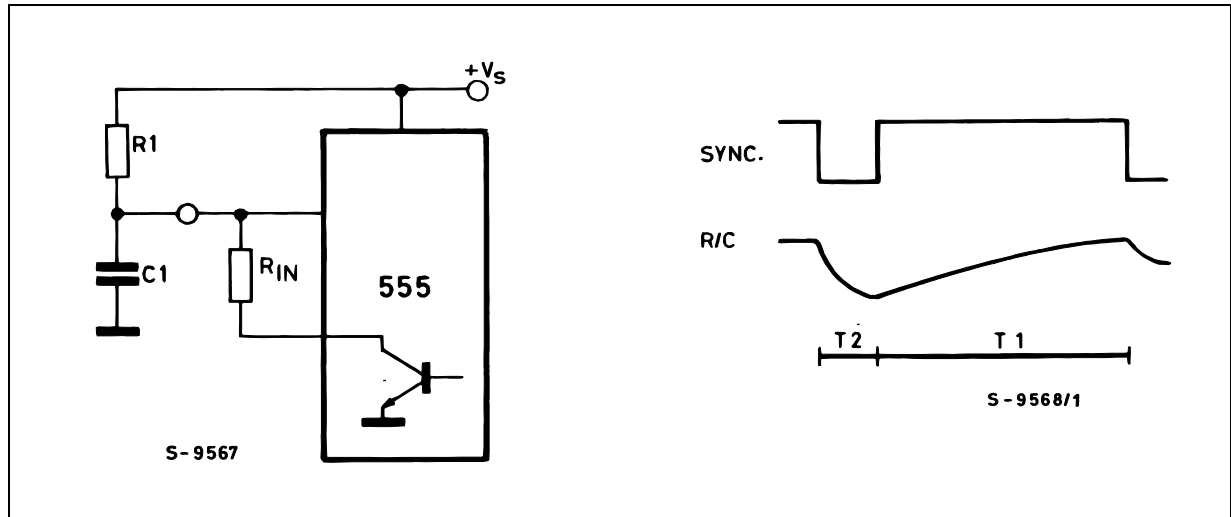

APPLICATIONS INFORMATION

The circuits shown in figure 2 use the L6506 to implement constant current drives for stepper motors. Figure 2 shows the L6506 used with the L298 to drive a 2 phase bipolar motor. The peak current can be calculated using the equation :

$$I_{peak} = \frac{V_{ref}}{R_{sense}}$$

The circuit of Fig.2 can be used in applications requiring different peak and hold current values by modifying the reference voltage.

The L6506 may be used to implement either full step or half step drives. In the case of 2 phase bipolar stepper motor applications, if a half step drive is used, the bridge requires an additional input to disable the power stage during the half step. If used in conjunction with the L298 the enable inputs may be used for this purpose.

For quad darlington array in 4 phase unipolar motor applications half step may be implemented using the 4 phase inputs.

The L6506 may also be used to implement microstepping of either bipolar or unipolar motors.

Figure 2 : Application Circuit Bipolar Stepper Motor Driver. (pin's number referred to DIP18)

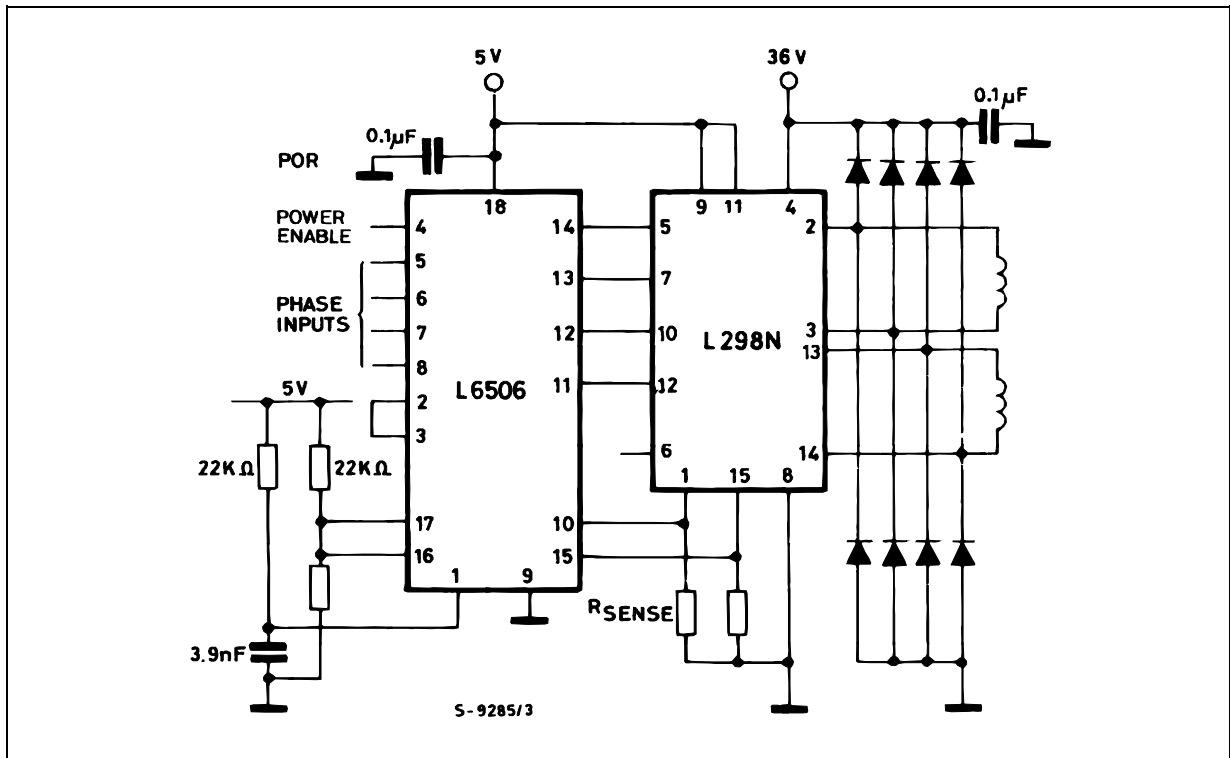

L6506 -L6506D

DIM.	mm			inch		
	MIN.	TYP.	MAX.	MIN.	TYP.	MAX.
a1	0.254			0.010		
B	1.39		1.65	0.055		0.065
b		0.46			0.018	
b1		0.25			0.010	
D			23.24			0.915
E		8.5			0.335	
e		2.54			0.100	
e3		20.32			0.800	
F			7.1			0.280
I			3.93			0.155
L		3.3			0.130	
Z		1.27	1.59		0.050	0.063

OUTLINE AND MECHANICAL DATA

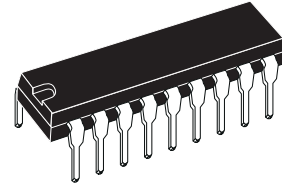

DIP18

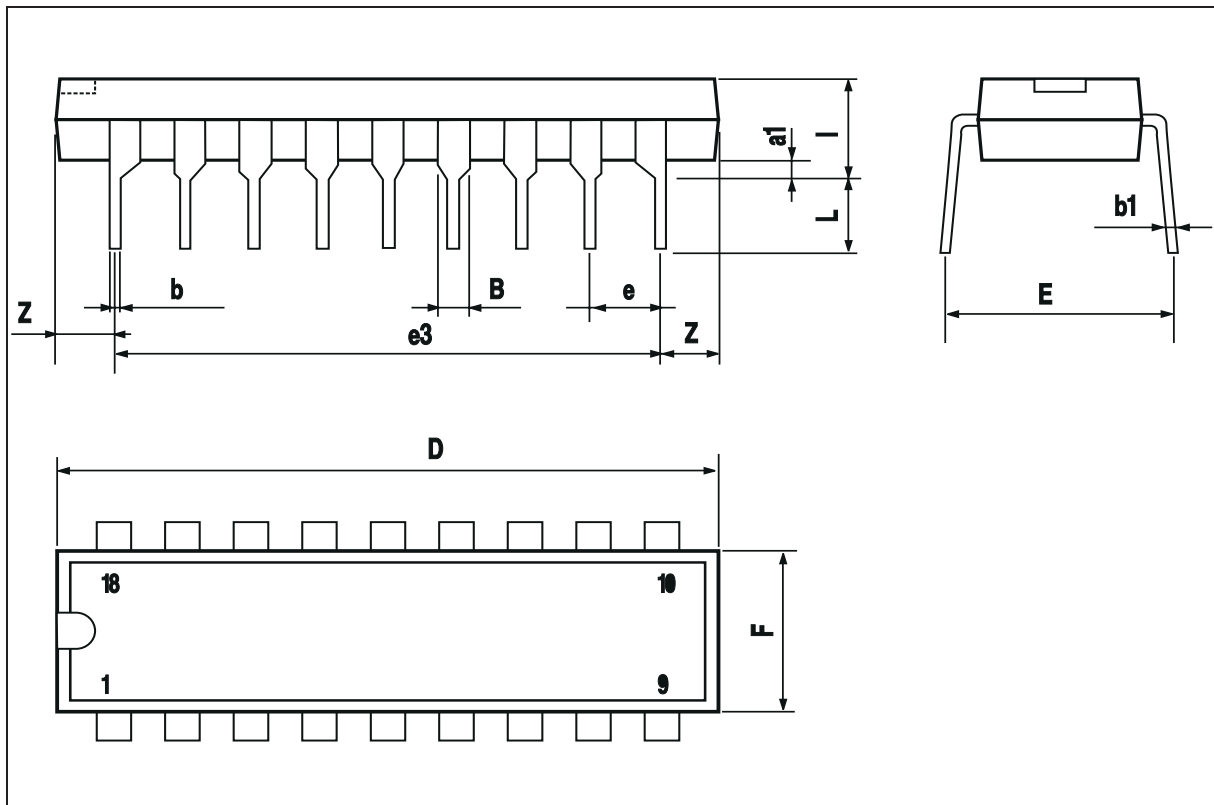

DIM.	mm			inch		
	MIN.	TYP.	MAX.	MIN.	TYP.	MAX.
A	2.35		2.65	0.093		0.104
A1	0.1		0.3	0.004		0.012
B	0.33		0.51	0.013		0.020
C	0.23		0.32	0.009		0.013
D	12.6		13	0.496		0.512
E	7.4		7.6	0.291		0.299
e		1.27			0.050	
H	10		10.65	0.394		0.419
h	0.25		0.75	0.010		0.030
L	0.4		1.27	0.016		0.050
K	0° (min.)8° (max.)					

OUTLINE AND MECHANICAL DATA

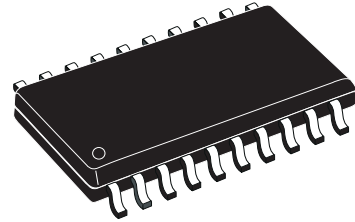

SO20

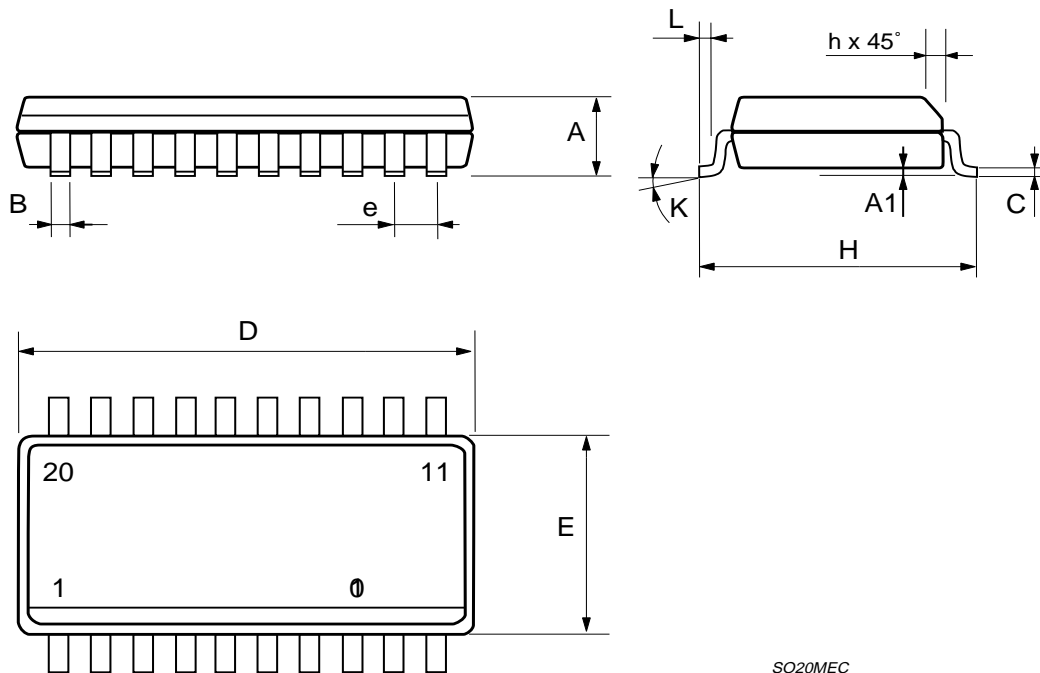

Information furnished is believed to be accurate and reliable. However, STMicroelectronics assumes no responsibility for the consequences of use of such information nor for any infringement of patents or other rights of third parties which may result from its use. No license is granted by implication or otherwise under any patent or patent rights of STMicroelectronics. Specification mentioned in this publication are subject to change without notice. This publication supersedes and replaces all information previously supplied. STMicroelectronics products are not authorized for use as critical components in life support devices or systems without express written approval of STMicroelectronics.

The ST logo is a registered trademark of STMicroelectronics
© 2003 STMicroelectronics – Printed in Italy – All Rights Reserved
STMicroelectronics GROUP OF COMPANIES

Australia - Brazil - Canada - China - Finland - France - Germany - Hong Kong - India - Israel - Italy - Japan - Malaysia - Malta - Morocco - Singapore - Spain - Sweden - Switzerland - United Kingdom - United States.

<http://www.st.com>



**Стандарт
Электрон
Связь**

Мы молодая и активно развивающаяся компания в области поставок электронных компонентов. Мы поставляем электронные компоненты отечественного и импортного производства напрямую от производителей и с крупнейших складов мира.

Благодаря сотрудничеству с мировыми поставщиками мы осуществляем комплексные и плановые поставки широчайшего спектра электронных компонентов.

Собственная эффективная логистика и склад в обеспечивает надежную поставку продукции в точно указанные сроки по всей России.

Мы осуществляем техническую поддержку нашим клиентам и предпродажную проверку качества продукции. На все поставляемые продукты мы предоставляем гарантию .

Осуществляем поставки продукции под контролем ВП МО РФ на предприятия военно-промышленного комплекса России , а также работаем в рамках 275 ФЗ с открытием отдельных счетов в уполномоченном банке. Система менеджмента качества компании соответствует требованиям ГОСТ ISO 9001.

Минимальные сроки поставки, гибкие цены, неограниченный ассортимент и индивидуальный подход к клиентам являются основой для выстраивания долгосрочного и эффективного сотрудничества с предприятиями радиоэлектронной промышленности, предприятиями ВПК и научно-исследовательскими институтами России.

С нами вы становитесь еще успешнее!

Наши контакты:

Телефон: +7 812 627 14 35

Электронная почта: sales@st-electron.ru

Адрес: 198099, Санкт-Петербург,
Промышленная ул, дом № 19, литера Н,
помещение 100-Н Офис 331