



Is Now Part of



**ON Semiconductor®**

To learn more about ON Semiconductor, please visit our website at  
[www.onsemi.com](http://www.onsemi.com)

Please note: As part of the Fairchild Semiconductor integration, some of the Fairchild orderable part numbers will need to change in order to meet ON Semiconductor's system requirements. Since the ON Semiconductor product management systems do not have the ability to manage part nomenclature that utilizes an underscore (\_), the underscore (\_) in the Fairchild part numbers will be changed to a dash (-). This document may contain device numbers with an underscore (\_). Please check the ON Semiconductor website to verify the updated device numbers. The most current and up-to-date ordering information can be found at [www.onsemi.com](http://www.onsemi.com). Please email any questions regarding the system integration to [Fairchild\\_questions@onsemi.com](mailto:Fairchild_questions@onsemi.com).

ON Semiconductor and the ON Semiconductor logo are trademarks of Semiconductor Components Industries, LLC dba ON Semiconductor or its subsidiaries in the United States and/or other countries. ON Semiconductor owns the rights to a number of patents, trademarks, copyrights, trade secrets, and other intellectual property. A listing of ON Semiconductor's product/patent coverage may be accessed at [www.onsemi.com/site/pdf/Patent-Marking.pdf](http://www.onsemi.com/site/pdf/Patent-Marking.pdf). ON Semiconductor reserves the right to make changes without further notice to any products herein. ON Semiconductor makes no warranty, representation or guarantee regarding the suitability of its products for any particular purpose, nor does ON Semiconductor assume any liability arising out of the application or use of any product or circuit, and specifically disclaims any and all liability, including without limitation special, consequential or incidental damages. Buyer is responsible for its products and applications using ON Semiconductor products, including compliance with all laws, regulations and safety requirements or standards, regardless of any support or applications information provided by ON Semiconductor. "Typical" parameters which may be provided in ON Semiconductor data sheets and/or specifications can and do vary in different applications and actual performance may vary over time. All operating parameters, including "Typicals" must be validated for each customer application by customer's technical experts. ON Semiconductor does not convey any license under its patent rights nor the rights of others. ON Semiconductor products are not designed, intended, or authorized for use as a critical component in life support systems or any FDA Class 3 medical devices or medical devices with a same or similar classification in a foreign jurisdiction or any devices intended for implantation in the human body. Should Buyer purchase or use ON Semiconductor products for any such unintended or unauthorized application, Buyer shall indemnify and hold ON Semiconductor and its officers, employees, subsidiaries, affiliates, and distributors harmless against all claims, costs, damages, and expenses, and reasonable attorney fees arising out of, directly or indirectly, any claim of personal injury or death associated with such unintended or unauthorized use, even if such claim alleges that ON Semiconductor was negligent regarding the design or manufacture of the part. ON Semiconductor is an Equal Opportunity/Affirmative Action Employer. This literature is subject to all applicable copyright laws and is not for resale in any manner.



# FSA642

## Low-Power, Three-Port, High-Speed MIPI Switch

### Features

- Low On Capacitance: 7.0 pF Typical
- Low On Resistance: 7.0 Ω Typical
- Wide -3db Bandwidth: 1 GHz Typical
- 24-Lead UMLP (2.5 x 3.4 mm) Package
- 8 kV ESD Rating; >16 kV Power/GND ESD Rating

### Applications

- Dual Camera Applications for Cell Phones
- Dual LCD Applications for Cell Phones, Digital Camera Displays, and Viewfinders

### Description

The FSA642 is a bi-directional, low-power, high-speed analog switch. The pin out is designed to ease differential signal layout and is configured as a triple-pole, double-throw switch (TPDT). The FSA642 is optimized for switching between two MIPI devices, such as cameras or LCD displays and on-board Multimedia Application Processors (MAP).

The FSA642 is compatible with the requirements of Mobile Industry Processor Interface (MIPI). The low-capacitance design allows the FSA642 to switch signals that exceed 500 MHz in frequency. Superior channel-to-channel crosstalk immunity minimizes interference and allows the transmission of high-speed differential signals and single-ended signals, as described by the MIPI specification.

### Ordering Information

Part Number	Top Mark	Operating Temperature Range	Package
FSA642UMX	JG	-40 to +85°C	24-Lead, Quad, Ultrathin Molded Leadless Package (UMLP), 2.5 x 3.4 mm

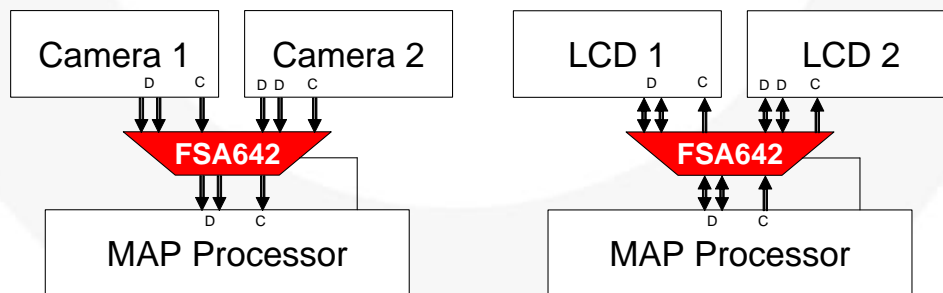


Figure 1. Application Block Diagram

## Pin Configuration

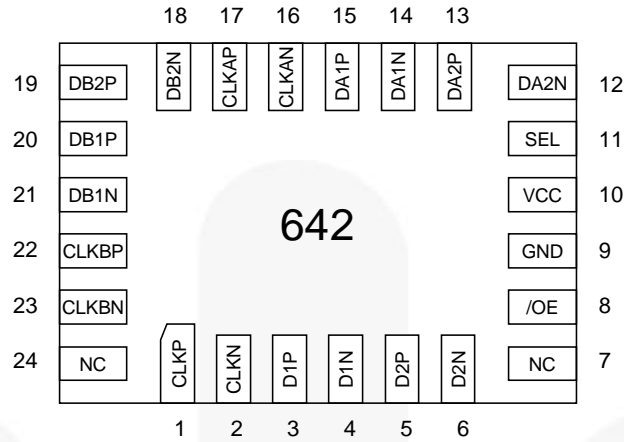


Figure 2. Pin Configuration (Top Through View)

## Pin Definitions

Pin #	Name	Description
1, 2	CLKP, CLKN	Clock Path (Common)
3, 4	D1P, D1N	Data Path 1 (Common)
5, 6	D2P, D2N	Data Path 2 (Common)
7, 24	NC	No Connect (Float)
8	/OE	Output Enable (Active Low)
9	GND	Ground
10	VCC	Power
11	SEL	Select (0=A, 1=B)
12, 13	DA2N, DA2P	Data Path (A2)
14, 15	DA1N, DA1P	Data Path (A1)
16, 17	CLKAN, CLKAP	Clock Path (A)
18, 19	DB2N, DB2P	Data Path (2B)
20, 21	DB1P, DB1N	Data Path (1B)
22, 23	CLKBP, CLKBN,	Clock Path (B)

### Functional Diagram

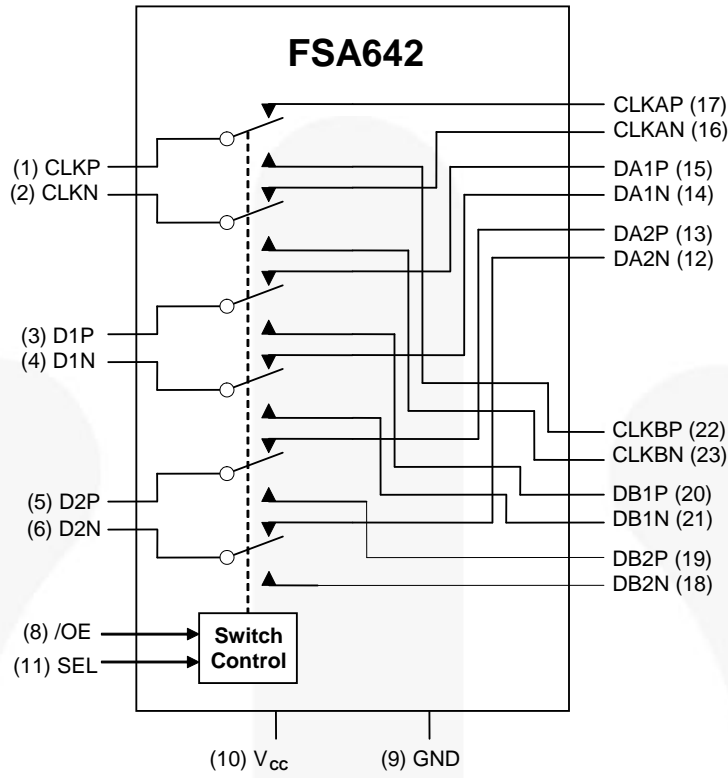


Figure 3. Functional Diagram

### Truth Table

SEL	/OE	Function
Don't Care	HIGH	Disconnect
LOW	LOW	D1, D2, CLK=DA1, DA2, CLKA
HIGH	LOW	D1, D2, CLK=DB1, DB2, CLKB

## Absolute Maximum Ratings

Stresses exceeding the absolute maximum ratings may damage the device. The device may not function or be operable above the recommended operating conditions and stressing the parts to these levels is not recommended. In addition, extended exposure to stresses above the recommended operating conditions may affect device reliability. The absolute maximum ratings are stress ratings only.

Symbol	Parameter	Min.	Max.	Unit
$V_{CC}$	Supply Voltage	-0.50	+5.25	V
$V_{CNTRL}$	DC Input Voltage (SEL, /OE) <sup>(1)</sup>	-0.5	$V_{CC}$	V
$V_{SW}$	DC Switch I/O Voltage <sup>(1)</sup>	-0.5	$V_{CC} + 0.3$	V
$I_{IK}$	DC Input Diode Current	-50		mA
$I_{OUT}$	DC Output Current		50	mA
$T_{STG}$	Storage Temperature	-65	+150	°C
ESD	Human Body Model, JEDEC: JESD22-A114	All Pins	6.5	kV
		I/O to GND	8.0	
		Power to GND	16.0	
	Charged Device Model, JEDEC: JESD22-C101		2.5	

**Note:**

1. The input and output negative ratings may be exceeded if the input and output diode current ratings are observed.

## Recommended Operating Conditions

The Recommended Operating Conditions table defines the conditions for actual device operation. Recommended operating conditions are specified to ensure optimal performance to the datasheet specifications. Fairchild does not recommend exceeding them or designing to Absolute Maximum Ratings.

Symbol	Parameter	Min.	Max.	Unit
$V_{CC}$	Supply Voltage	2.65	4.30	V
$V_{CNTRL}$	Control Input Voltage (SEL, /OE) <sup>(2)</sup>	0	$V_{CC}$	V
$V_{SW}$	Switch I/O Voltage	-0.5	$V_{CC}-1$	V
$T_A$	Operating Temperature	-40	+85	°C

**Note:**

2. The control input must be held HIGH or LOW; it must not float.

## DC Electrical Characteristics

All typical values are  $T_A=25^\circ\text{C}$  unless otherwise specified.

Symbol	Parameter	Conditions	$V_{CC}$ (V)	$T_A=-40$ to $+85^\circ\text{C}$			Units
				Min.	Typ.	Max.	
$V_{IK}$	Clamp Diode Voltage	$I_{IN}=-18$ mA	2.775			-1.2	V
$I_{IN}$	Control Input Leakage	$V_{SW}=0$ to 4.3 V	4.3	-1		1	$\mu\text{A}$
$V_{IH}$	Input Voltage High	$V_{IN}=0$ to $V_{CC}$	2.650 to 2.775	1.3			V
			4.3	1.7			
$V_{IL}$	Input Voltage Low	$V_{IN}=0$ to $V_{CC}$	2.650 to 2.775			0.5	V
$I_{OZ}$	Off-State Leakage	A,B=0+0.3 V to $V_{CC}-0.3$	4.3	-2		2	$\mu\text{A}$
$I_{CC}$	Quiescent Supply Current	$V_{CNTRL}=0$ or $V_{CC}$ , $I_{OUT}=0$	4.3			1.0	$\mu\text{A}$
$I_{CCT}$	Increase in $I_{CC}$ Current Per Control Voltage and $V_{CC}$	$V_{CNTRL}=1.8$ V	2.775			1.5	$\mu\text{A}$

## DC Electrical Characteristics, Low-Speed Mode

All typical values are  $T_A=25^\circ\text{C}$  unless otherwise specified.

Symbol	Parameter	Conditions	$V_{CC}$ (V)	$T_A=-40$ to $+85^\circ\text{C}$			Units
				Min.	Typ.	Max.	
$R_{ON}$	LS Switch On Resistance <sup>(3)</sup>	$V_{SW}=1.2$ V, $I_{ON}=-10$ mA, Figure 4	2.65		10	14	$\Omega$
$\Delta R_{ON}$	LS Delta $R_{ON}$ <sup>(4)</sup>	$V_{SW}=1.2$ V, $I_{ON}=-10$ mA (Intra-pair)	2.65		0.65		$\Omega$

### Notes:

- Measured by the voltage drop between A/B and CLK/Dn pins at the indicated current through the switch.
- Guaranteed by characterization.

## DC Electrical Characteristics, High-Speed Mode

All typical values are  $T_A=25^\circ\text{C}$  unless otherwise specified.

Symbol	Parameter	Conditions	$V_{CC}$ (V)	$T_A=-40$ to $+85^\circ\text{C}$			Units
				Min.	Typ.	Max.	
$R_{ON}$	HS Switch On Resistance <sup>(5)</sup>	$V_{SW}=0.4$ V, $I_{ON}=-10$ mA, Figure 4	2.65		7.0	9.5	$\Omega$
$\Delta R_{ON}$	HS Delta $R_{ON}$ <sup>(6)</sup>	$V_{SW}=0.4$ V, $I_{ON}=-10$ mA (Intra-pair)	2.65		0.65		$\Omega$

### Notes:

- Measured by the voltage drop between A, B, and Dn pins at the indicated current through the switch.
- Guaranteed by characterization.

## AC Electrical Characteristics

All values are at  $R_L=50\Omega$  and  $R_S=50\Omega$  and all typical values are  $V_{CC}=2.775V$  at  $T_A=25^\circ C$  unless otherwise specified.

Symbol	Parameter	Conditions	$V_{CC}$ (V)	$T_A=-40^\circ C$ to $+85^\circ C$			Units
				Min.	Typ.	Max.	
$O_{IRR}$	Off Isolation <sup>(7)</sup>	$f=100$ MHz, $R_T=50\ \Omega$ Figure 14	2.775		-35		dB
Xtalk	Non-Adjacent Channel Crosstalk <sup>(7)</sup>	$f=100$ MHz, $R_T=50\ \Omega$ Figure 15	2.775		-55		dB
BW	-3 db Bandwidth <sup>(7)</sup>	$C_L=0$ pF, $R_T=50\ \Omega$ Figure 13	2.775		1.0		GHz
$t_{ON}$	Turn-On Time SEL, /OE to Output	$C_L=5$ pF, $V_{SW}=1.2$ V Figure 6, Figure 7	2.650 to 2.775		20	37	ns
$t_{OFF}$	Turn-Off Time SEL, /OE to Output	$C_L=5$ pF, $V_{SW}=1.2$ V Figure 6, Figure 7	2.650 to 2.775		15	27	ns
$t_{PD}$	Propagation Delay <sup>(7)</sup>	$C_L=5$ pF Figure 6, Figure 8	2.775		0.25		ns
$t_{BBM}$	Break-Before-Make Time	$C_L=5$ pF, $V_{SW1}=V_{SW2}=1.2$ V Figure 12	2.650 to 2.775	3	5	8	ns

### Note:

7. Guaranteed by characterization.

## AC Electrical Characteristics, High-Speed

All typical values are  $V_{CC}=2.775V$  at  $T_A=25^\circ C$  unless otherwise specified.

Symbol	Parameter	Conditions	$T_A=-40^\circ C$ to $+85^\circ C$			Units
			Min.	Typ.	Max.	
$t_{SK(Part\_Part)}$	Channel-to-Channel Skew Across Multiple Parts <sup>(8,9)</sup>	$V_{SW}=0.2$ VdiffPP, $C_L=5$ pF		40	80	ps
$t_{SK(Chl\_Chl)}$	Channel-to-Channel Skew Within a Single Part <sup>(8)</sup>	$V_{SW}=0.2$ VdiffPP, $C_L=5$ pF, Figure 9		15	30	ps
$t_{SK(Pulse)}$	Skew of Opposite Transitions in the Same Differential Channel <sup>(8)</sup>	$V_{SW}=0.2$ VdiffPP, $C_L=5$ pF		10	20	ps

### Notes:

8. Guaranteed by characterization.

9. Assumes the same  $V_{CC}$  and temperature for all devices.

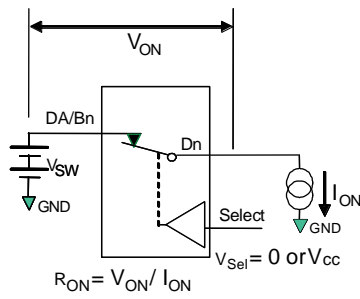
## Capacitance

Symbol	Parameter	Conditions	$T_A=-40^\circ C$ to $+85^\circ C$			Units
			Min.	Typ.	Max.	
$C_{IN}$	Control Pin Input Capacitance <sup>(10)</sup>	$V_{CC}=0$ V		1.5		pF
$C_{ON}$	Dn/CLK- On Capacitance <sup>(10)</sup>	$V_{CC}=2.775$ V, /OE=0 V, $f=1$ MHz, at $25^\circ C$ , Figure 11	6.0	7.0	9.0	
$C_{OFF}$	Dn/CLK Off Capacitance <sup>(10)</sup>	$V_{CC}=2.775$ V, /OE=2.775 V, $f=1$ MHz, Figure 10		2.5		

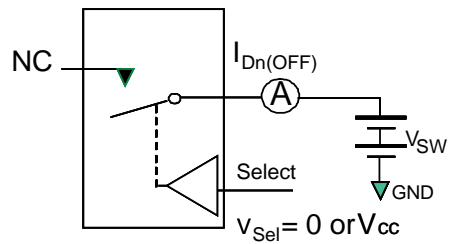
### Note:

10. Guaranteed by characterization.

## Test Diagrams

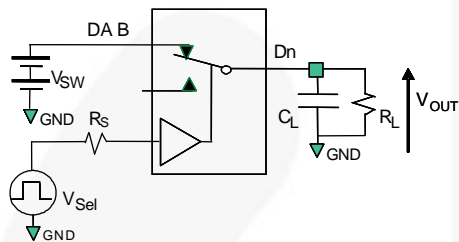


**Figure 4. On Resistance**



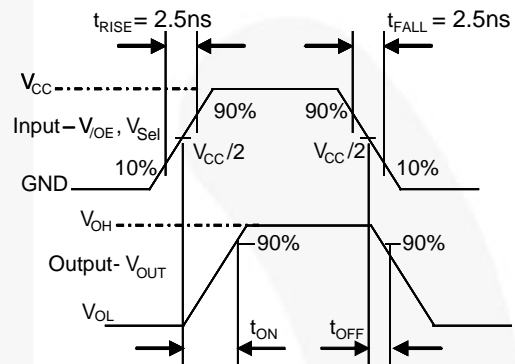
\*\*Each switch port is tested separately

**Figure 5. Off Leakage**

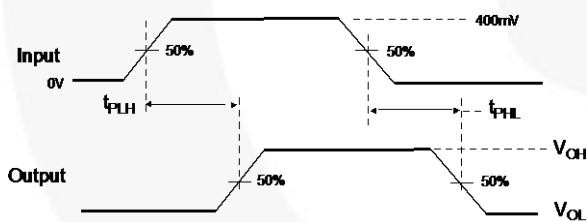


$R_L$ ,  $R_S$ , and  $C_L$  are functions of the application environment (see AC Tables for specific values).  $C_L$  includes test fixture and stray capacitance.

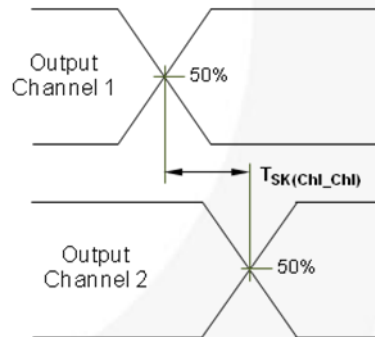
**Figure 6. AC Test Circuit Load**



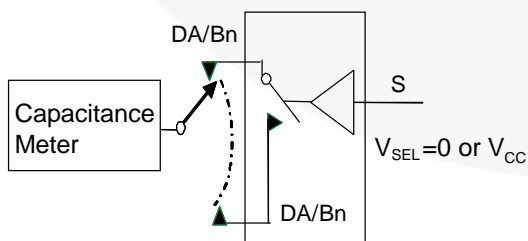
**Figure 7. Turn-On / Turn-Off Waveforms**



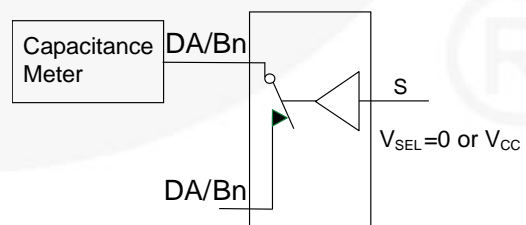
**Figure 8. Propagation Delay ( $t_{rtf} = 500$  ps)**



**Figure 9. Channel-to-Channel Skew**



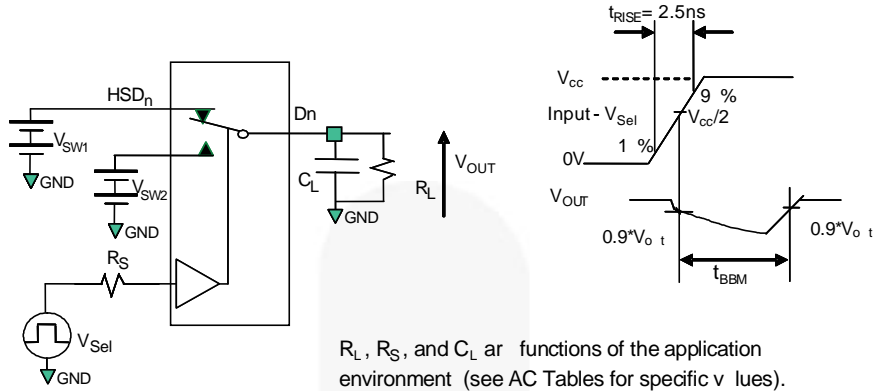
**Figure 10. Channel Off Capacitance**



**Figure 11. Channel On Capacitance**

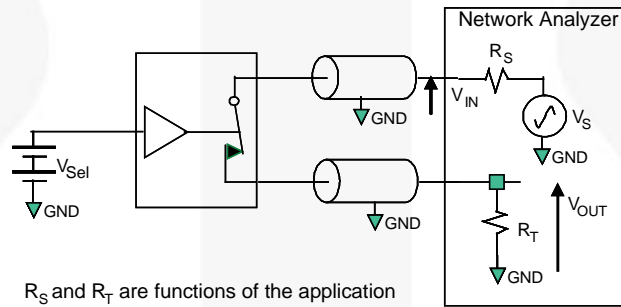


Test Diagrams (Continued)



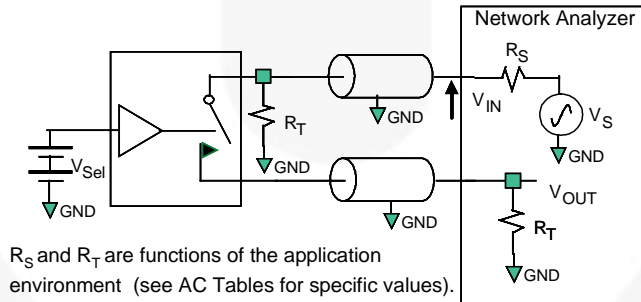
$R_L$ ,  $R_S$ , and  $C_L$  are functions of the application environment (see AC Tables for specific values).  $C_L$  includes test fixture and stray capacitance.

Figure 12. Break-Before-Make Interval Timing



$R_S$  and  $R_T$  are functions of the application environment (see AC Tables for specific values).

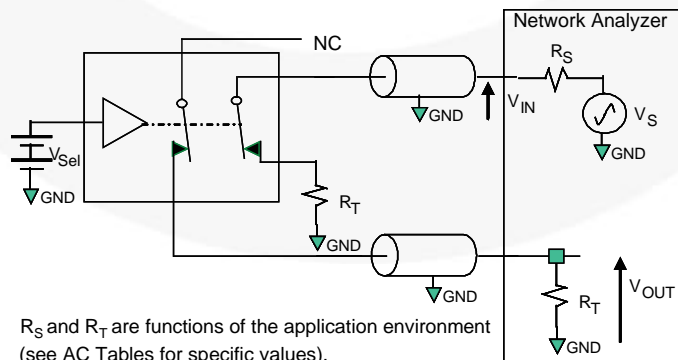
Figure 13. Bandwidth



$R_S$  and  $R_T$  are functions of the application environment (see AC Tables for specific values).

$$\text{Off isolation} = 20 \text{ Log} (V_{OUT} / V_{IN})$$

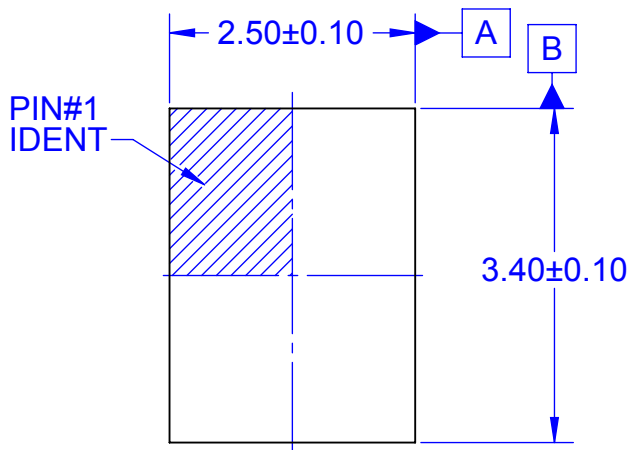
Figure 14. Channel Off Isolation



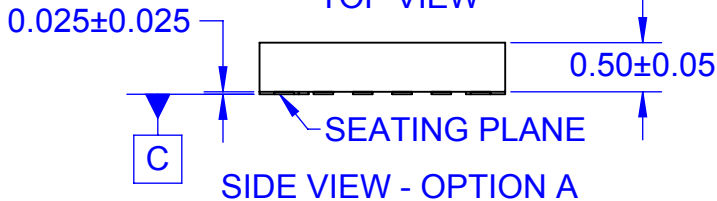
$R_S$  and  $R_T$  are functions of the application environment (see AC Tables for specific values).

$$\text{Crosstalk} = 20 \text{ Log} (V_{OUT} / V_{IN})$$

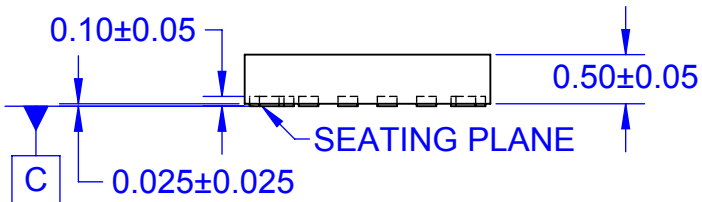
Figure 15. Non-Adjacent Channel-to-Channel Crosstalk



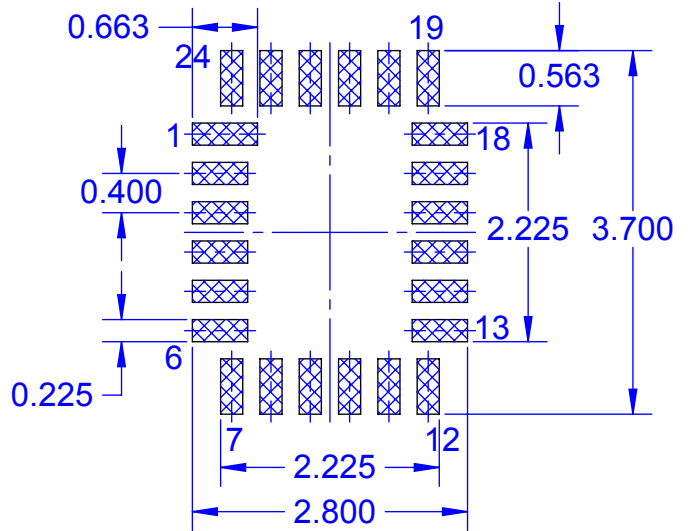
TOP VIEW



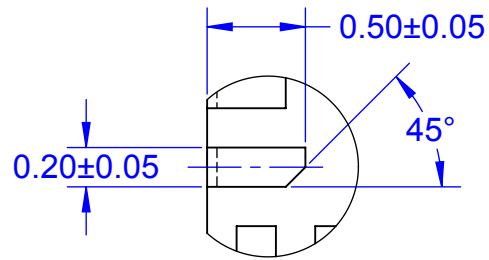
SIDE VIEW - OPTION A



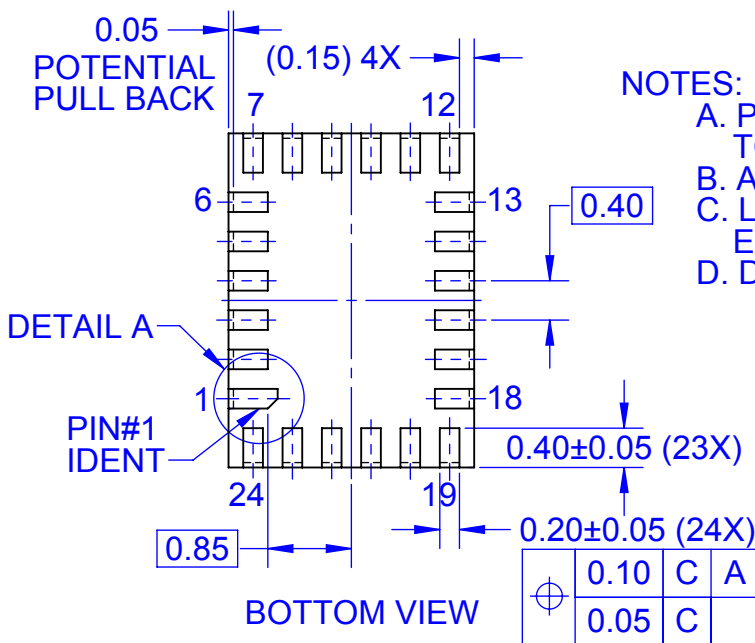
SIDE VIEW - OPTION B



LAND PATTERN RECOMMENDATION



DETAIL A  
SCALE 2:1



BOTTOM VIEW

NOTES:

- A. PACKAGE DOES NOT FULLY CONFORM TO JEDEC STANDARD
- B. ALL DIMENSIONS ARE IN MILLIMETERS
- C. LAND PATTERN RECOMMENDATION IS EXISTING INDUSTRY LAND PATTERN
- D. DRAWING FILENAME: MKT-UMLP24ArevE

⊕	0.10	C	A	B
	0.05	C		

**ON Semiconductor**



ON Semiconductor and  are trademarks of Semiconductor Components Industries, LLC dba ON Semiconductor or its subsidiaries in the United States and/or other countries. ON Semiconductor owns the rights to a number of patents, trademarks, copyrights, trade secrets, and other intellectual property. A listing of ON Semiconductor's product/patent coverage may be accessed at [www.onsemi.com/site/pdf/Patent-Marking.pdf](http://www.onsemi.com/site/pdf/Patent-Marking.pdf). ON Semiconductor reserves the right to make changes without further notice to any products herein. ON Semiconductor makes no warranty, representation or guarantee regarding the suitability of its products for any particular purpose, nor does ON Semiconductor assume any liability arising out of the application or use of any product or circuit, and specifically disclaims any and all liability, including without limitation special, consequential or incidental damages. Buyer is responsible for its products and applications using ON Semiconductor products, including compliance with all laws, regulations and safety requirements or standards, regardless of any support or applications information provided by ON Semiconductor. "Typical" parameters which may be provided in ON Semiconductor data sheets and/or specifications can and do vary in different applications and actual performance may vary over time. All operating parameters, including "Typicals" must be validated for each customer application by customer's technical experts. ON Semiconductor does not convey any license under its patent rights nor the rights of others. ON Semiconductor products are not designed, intended, or authorized for use as a critical component in life support systems or any FDA Class 3 medical devices or medical devices with a same or similar classification in a foreign jurisdiction or any devices intended for implantation in the human body. Should Buyer purchase or use ON Semiconductor products for any such unintended or unauthorized application, Buyer shall indemnify and hold ON Semiconductor and its officers, employees, subsidiaries, affiliates, and distributors harmless against all claims, costs, damages, and expenses, and reasonable attorney fees arising out of, directly or indirectly, any claim of personal injury or death associated with such unintended or unauthorized use, even if such claim alleges that ON Semiconductor was negligent regarding the design or manufacture of the part. ON Semiconductor is an Equal Opportunity/Affirmative Action Employer. This literature is subject to all applicable copyright laws and is not for resale in any manner.

## PUBLICATION ORDERING INFORMATION

### LITERATURE FULFILLMENT:

Literature Distribution Center for ON Semiconductor  
19521 E. 32nd Pkwy, Aurora, Colorado 80011 USA  
**Phone:** 303-675-2175 or 800-344-3860 Toll Free USA/Canada  
**Fax:** 303-675-2176 or 800-344-3867 Toll Free USA/Canada  
**Email:** [orderlit@onsemi.com](mailto:orderlit@onsemi.com)

**N. American Technical Support:** 800-282-9855 Toll Free  
USA/Canada  
**Europe, Middle East and Africa Technical Support:**  
Phone: 421 33 790 2910  
**Japan Customer Focus Center**  
Phone: 81-3-5817-1050

**ON Semiconductor Website:** [www.onsemi.com](http://www.onsemi.com)  
**Order Literature:** <http://www.onsemi.com/orderlit>  
For additional information, please contact your local  
Sales Representative

# Mouser Electronics

Authorized Distributor

Click to View Pricing, Inventory, Delivery & Lifecycle Information:

[ON Semiconductor:](#)

[FSA642UMX](#)



## Стандарт Электрон Связь

Мы молодая и активно развивающаяся компания в области поставок электронных компонентов. Мы поставляем электронные компоненты отечественного и импортного производства напрямую от производителей и с крупнейших складов мира.

Благодаря сотрудничеству с мировыми поставщиками мы осуществляем комплексные и плановые поставки широчайшего спектра электронных компонентов.

Собственная эффективная логистика и склад в обеспечивает надежную поставку продукции в точно указанные сроки по всей России.

Мы осуществляем техническую поддержку нашим клиентам и предпродажную проверку качества продукции. На все поставляемые продукты мы предоставляем гарантию .

Осуществляем поставки продукции под контролем ВП МО РФ на предприятия военно-промышленного комплекса России , а также работаем в рамках 275 ФЗ с открытием отдельных счетов в уполномоченном банке. Система менеджмента качества компании соответствует требованиям ГОСТ ISO 9001.

Минимальные сроки поставки, гибкие цены, неограниченный ассортимент и индивидуальный подход к клиентам являются основой для выстраивания долгосрочного и эффективного сотрудничества с предприятиями радиоэлектронной промышленности, предприятиями ВПК и научно-исследовательскими институтами России.

С нами вы становитесь еще успешнее!

### Наши контакты:

**Телефон:** +7 812 627 14 35

**Электронная почта:** [sales@st-electron.ru](mailto:sales@st-electron.ru)

**Адрес:** 198099, Санкт-Петербург,  
Промышленная ул, дом № 19, литера Н,  
помещение 100-Н Офис 331