

WISE-3610

Wireless IoT LoRa Network Gateway



Features

- Qualcomm Atheros Quad-Core ARM Cortex-A7 SoC
- Built-in Dual Band Concurrent Wi-Fi MU-MIMO (2x2)
- LPWAN LoRa Private (WISE-Link) Connectivity
- WAN x1 / LAN x1 Gigabit Ethernet
- Integration of Modbus TCP and Modbus RTU networks
- IPSec / L2TP VPN Traffic Encryption
- Rich Network Scenario by S/W Configuration
- Modularization hardware design
- OpenWRT BSP embedded
- Web UI user interface

Introduction

WISE-3610 is Qualcomm ARM Cortex A based hardware platform, which is operating at OpenWRT, described as a Linux distribution for embedded devices. The Advantech WISE-3610 Industrial Router is Advantech IoT gateway design for smart city, Industrial 4.0 applications, even those in harsh environment, leveraging wireless sensor technology. This IoT gateway can aggregate both the wireless sensor networks (WSN), including Low Power WAN (LPWAN) technology by Advantech private LoRa technology, wired sensors and ties them into an IP network. With modular slot design, it can agilely adapt to a variety of wireless technologies at regional RF bands, wireless communication protocol by various uplink requirement and quickly go to market.

Specifications

Processor System	CPU	QCA Quad-core ARM Cortex A7 CPU 716 MHz	
	RAM	DDR3L 256MB	
	Flash	128MB	
Ethernet	WAN	1 10/100/1000 Mbps	
	LAN	1 10/100/1000 Mbps	
Security	VPN Engine	IPsec, L2TP	
Connectivity	Wi-Fi	2x2 IEEE802.11a/b/g/n/ac MU-MIMO 2.4GHz / 5GHz	Enabled by Qualcomm® VIVE™ technology
	LoRa	LoRa Private Network - WISE-Link	Support up to 500pcs WISE-1510 sensor nodes
	3G/LTE (Option)	3G miniPCIe card	3G Band Support: B5, B8, B2, B1, B4
Expansion	SD socket	1 x microSD socket	up to 128GB
	mini PCIe	1 x Full size mini PCIe slot	Reserved for 3G/LTE module
	SIM	2 x Micro SIM slot	
I/O (Edge)	USB	1 x USB 3.0 type A	
	Serial Port	1 x RS-232/422/485 (DB9 Male)	Default configuration: RS-485
	Antenna	6 x SMA Connector	Wi-Fi: 2 x RP-SMA LoRa: 2 x SMA Optional for 3G: 2 x SMA (1 x Rx Diversity)
	LED	6 x PWR/LoRa/Wi-Fi 2G/Wi-Fi 5G/USB/WWAN	
	Button	1 x Reset button	
Power	Power Supply Voltage	9 - 24V	
	Power Type	DC-in	
	Power Consumption	18 Watt	
Environment	Operational Temperature	-20 ~ 70 degree C	
	Operating Humidity	10% ~ 95% @ 40°C relative humidity, non-condensing	
Mechanical	Dimensions (W x D x H)	187.9mm x 150mm x 39mm	
ModBus	ModBus TCP / RTU Translator		
Operating System	OpenWRT Barrier Breaker (Linux 3.14)		
Network Sub-system	L2/3 multilayer switch / router		
	Access Control List mask rules		
	Hardware network address translation (NAT) engine		
Network Connectivity	4 x scenario configurations by corresponding communication network support - NorthBond: WWAN (3G), WAN, Wi-Fi (2.4Ghz or 5Ghz) - SouthBond: LAN, Wi-Fi (2.4Ghz or 5Ghz), LoRa		Depend on different application environment for corresponding configuration
Cloud	WISE-PaaS / RMM Cloud		
Certification	TELEC, CE/FCC/IC Class B, SRRC, NCC		

Dimensions

Unit: mm

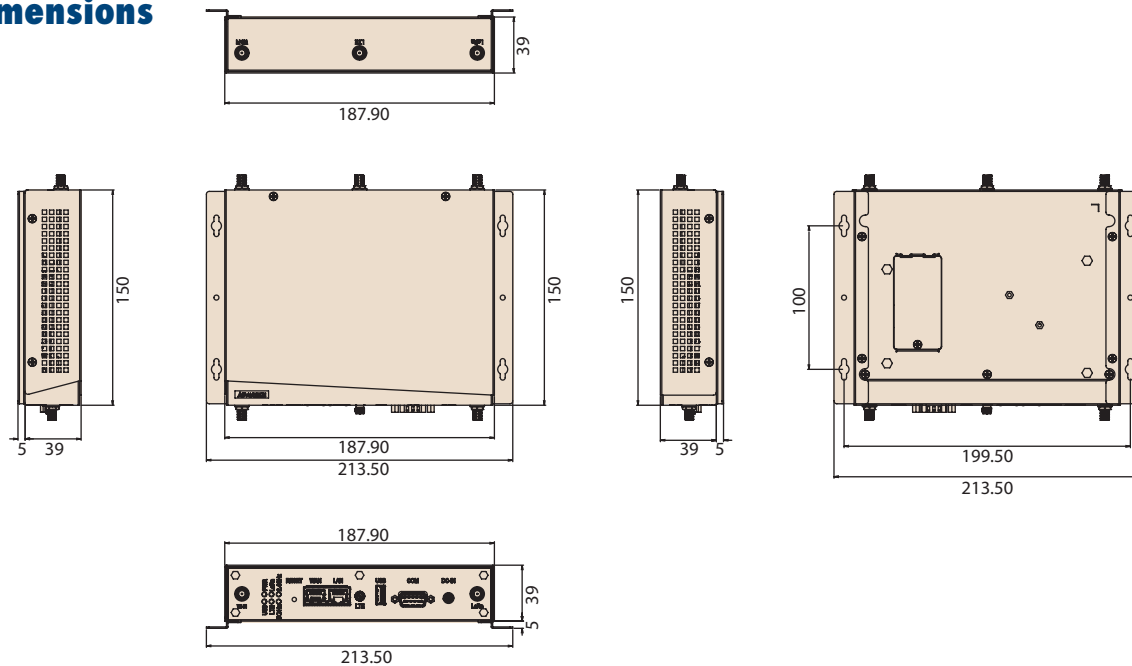

Software Key Features

Completed Software Services

- Modbus TCP and Modbus RTU networks
- Rich network scenario configuration
- Point-to-point VPN encryption engine
- Network routing path acceleration
- WISE-Agent

Easy-use from sensor to cloud

- WISE-Link LoRa Private Network
- Web UI setting for WSN, Gateway and Cloud
- IoT communication with MQTT protocol
- WISE-Agent connect to WISE-PaaS/RMM

Ordering Information

Part Number	Description
WISE-3610ILS-51A1N	WISE-3610 Private LoRa Network IoT Gateway NA915
WISE-3610ILS-51A1E	WISE-3610 Private LoRa Network IoT Gateway EU868
WISE-3610ILS-51A1J	WISE-3610 Private LoRa Network IoT Gateway JP923
WISE-3610ILS-51A1C	WISE-3610 Private LoRa Network IoT Gateway CN470

Related Models

Model Name	Description
WISE-1510WMB-SDA1N	WISE-1510 M2.COM LoRa module-NA915
WISE-1510WMB-SDA1E	WISE-1510 M2.COM LoRa module-EU868
WISE-1510WMB-SDA1J	WISE-1510 M2.COM LoRa module-JP923
WISE-1510WMB-SDA1C	WISE-1510 M2.COM LoRa module-CN470
WISE-1520ITB-TDA1E	WISE-1520 M2.COM Wi-Fi module

Packing List

Part Number	Description	Quantity
WISE-3610	WISE-3610 Wireless IoT Gateway	1
96PSA-A36W12R1	36W 12V 3A AC/DC Power Adaptor	1
1750008001-01	Antenna 2.4Ghz / 5Ghz SMA Male Reverse	2
1750008599-01	LoRa Dipole Antenna, 1dBi 863-870 MHz (EU868 SKU)	2
1750008598-01	LoRa Dipole Antenna, 1dBi 902-928 MHz (NA915, JP923 SKUs)	2
1750008771-01	LoRa Dipole Antenna, 1.5dBi 470-510 MHz (CN470 SKU)	2
Mounting Bracket	Wall Mounting Bracket Kit with Screws	1

Optional Items

Part No.	Description
1700001524	Power Cable 3-pin 180cm, USA type
170203183C	Power Cable 3-pin 180cm, Europe type
170203180A	Power Cable 3-pin 180cm, UK type
1700008921	Power Cable 3-pin PSE Mark 183cm
1750008424-01	3G/LTE Antenna Dipole 4dBi Full Band
1750008669-01	3G/LTE RX Diversity Antenna Cable IPEX to IPEX Connector
968EMW0093	Mini PCIE HSPA 3G Card with Rx Diversity



Стандарт Электрон Связь

Мы молодая и активно развивающаяся компания в области поставок электронных компонентов. Мы поставляем электронные компоненты отечественного и импортного производства напрямую от производителей и с крупнейших складов мира.

Благодаря сотрудничеству с мировыми поставщиками мы осуществляем комплексные и плановые поставки широчайшего спектра электронных компонентов.

Собственная эффективная логистика и склад в обеспечивает надежную поставку продукции в точно указанные сроки по всей России.

Мы осуществляем техническую поддержку нашим клиентам и предпродажную проверку качества продукции. На все поставляемые продукты мы предоставляем гарантию .

Осуществляем поставки продукции под контролем ВП МО РФ на предприятия военно-промышленного комплекса России , а также работаем в рамках 275 ФЗ с открытием отдельных счетов в уполномоченном банке. Система менеджмента качества компании соответствует требованиям ГОСТ ISO 9001.

Минимальные сроки поставки, гибкие цены, неограниченный ассортимент и индивидуальный подход к клиентам являются основой для выстраивания долгосрочного и эффективного сотрудничества с предприятиями радиоэлектронной промышленности, предприятиями ВПК и научно-исследовательскими институтами России.

С нами вы становитесь еще успешнее!

Наши контакты:

Телефон: +7 812 627 14 35

Электронная почта: sales@st-electron.ru

Адрес: 198099, Санкт-Петербург,
Промышленная ул, дом № 19, литера Н,
помещение 100-Н Офис 331