

# NHD-7.0-800480WF-CTXI#-T

## TFT (Thin-Film-Transistor) Color Liquid Crystal Display Module

NHD-	Newhaven Display
7.0-	7.0" Diagonal
800480-	800xRGBx480 pixels
WF-	Model
C-	Built-in Controller
T-	White LED backlight
X-	TFT
I-	6:00 view, Wide Temp
#-	<b>RoHS Compliant</b>
T-	Touch Panel

**Newhaven Display International, Inc.**

2511 Technology Drive, Suite 101

Elgin IL, 60124

Ph: 847-844-8795

Fax: 847-844-8796

[www.newhavendisplay.com](http://www.newhavendisplay.com)

[nhtech@newhavendisplay.com](mailto:nhtech@newhavendisplay.com)

[nhsales@newhavendisplay.com](mailto:nhsales@newhavendisplay.com)

## Document Revision History

Revision	Date	Description	Changed by
0	8/31/2010	Initial Release	MC
1	10/5/2010	Mechanical Drawing updated	BE
2	2/8/2011	Initialization code added	AK
3	2/23/2011	Grammar/symbols updated	BE
4	10/7/2011	Backlight and Touch Panel pin descriptions added	AK
5	1/6/2012	Pixel data format updated	AK

## Functions and Features

- 800xRGBx480 resolution
- LED backlight
- 8-bit digital RGB interface
- 262,144 colors
- SSD1963 8-bit controller

# Mechanical Drawing

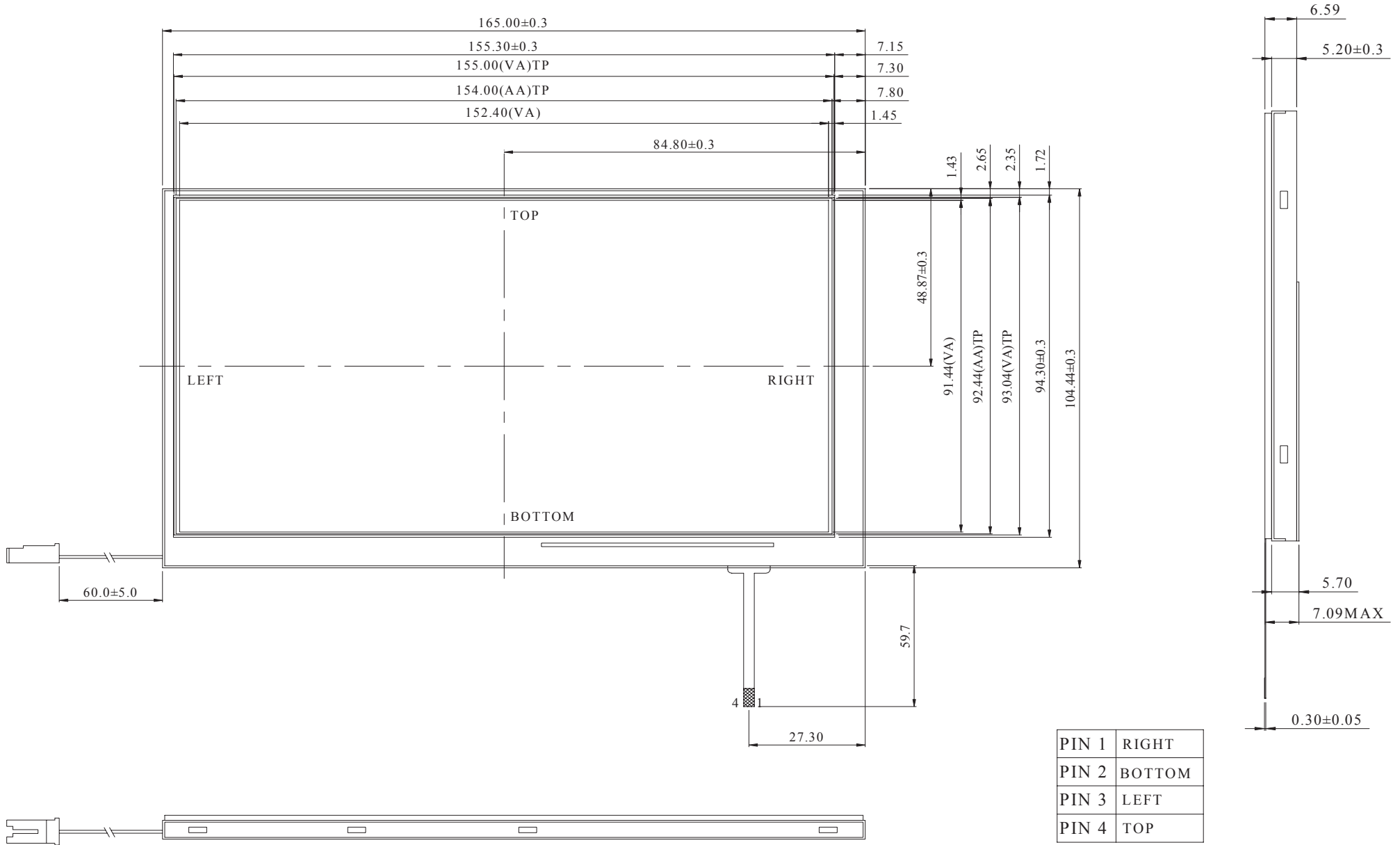

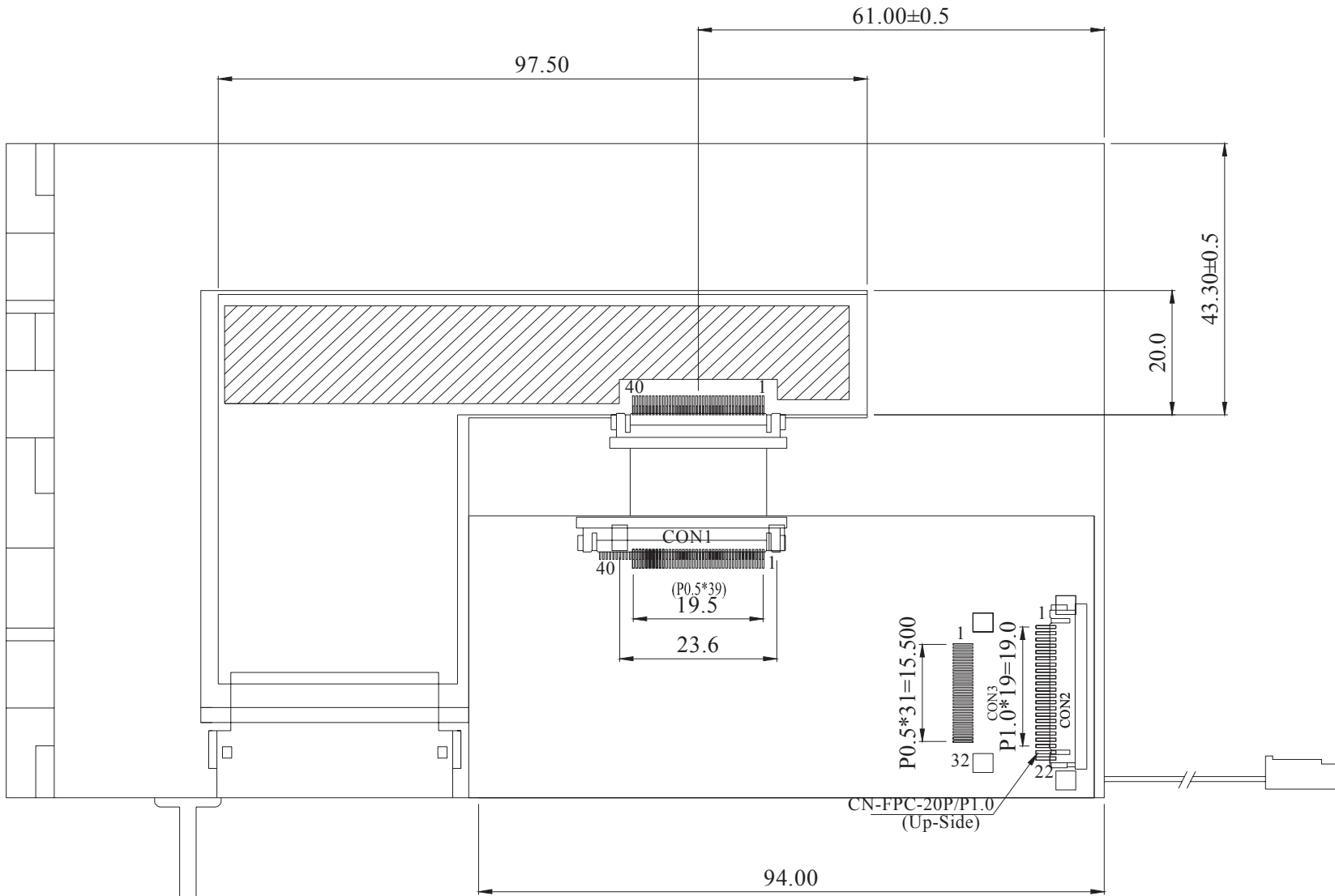

PIN NO.	SYMBOL
1	GND
2	VDD
3	VO
4	A0
5	R/W
6	E
7	DB0
8	DB1
9	DB2
10	DB3
11	DB4
12	DB5
13	DB6
14	DB7
15	CS
16	NC
17	NC
18	RST
19	NC
20	NC

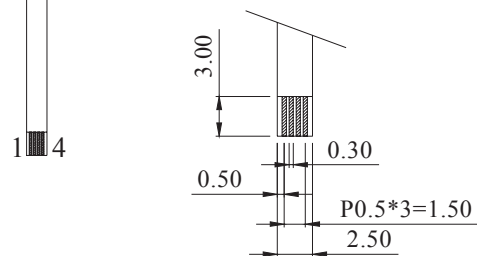

## CON2 LCD Pin Description

Pin No.	Symbol	Connection	Function Description
1	GND	Power Supply	Ground
2	VDD	Power Supply	Power supply for logic (+3.3V)
3	NC	-	No Connect
4	D/C#	MPU	Register Select signal: 1=Data, 0=Command
5	WR#	MPU	Active LOW Write signal (8080 mode) Read/Write signal (6800 mode)
6	RD#	MPU	Active LOW Read signal (8080 mode) Edge trigger Enable signal (6800 mode)
7-14	DB0~DB7	MPU	8-bit bi-directional data bus
15	CS#	MPU	Active LOW Chip Select signal
16	NC	-	No Connect
17	NC	-	No Connect
18	RST#	MPU	Active LOW Reset signal
19	NC	-	No Connect
20	NC	-	No Connect

**LCD connector:** 1.0mm pitch,20-Conductor FFC, top contact

**Recommended connection:** 1.0mm pitch, 20-conductor FFC cable

## CON1 TFT Pin-Out (before controller board):

Pin No.	Symbol	Connection	Function Description
1	GND	Power Supply	Power Ground
2	GND	Power Supply	Power Ground
3	NC	-	No connect
4-7	VDD	Power Supply	Power Supply (+3.3V)
8	NC	-	No connect
9	DE	MPU	Data Enable
10-12	GND	Power Supply	Power Ground
13-15	B5-B3	MPU	Blue B5 (MSB) to B3
16	GND	Power Supply	Power Ground
17-19	B2-B0	MPU	Blue B2 – B0(LSB)
20	GND	Power Supply	Power Ground
21-23	G5-G3	MPU	Green B5 (MSB) to B3
24	GND	Power Supply	Power Ground
25-27	G2-G0	MPU	Green B2 – B0(LSB)
28	GND	Power Supply	Power Ground
29-31	R5-R3	MPU	Red B5 (MSB) to B3
32	GND	Power Supply	Power Ground
33-35	R2-R0	MPU	Red B2 – B0(LSB)
36-37	GND	Power Supply	Power Ground
38	DCLK	MPU	Clock (Falling edge triggered)
39-40	GND	Power Supply	Power Ground

**LCD connector:** 0.5mm pitch,40-Conductor FFC, Bottom contact

**Recommended connection:** 0.5mm pitch, 40-conductor FFC cable

## Backlight Pin-Out:

Pin No.	Symbol	Connection	Function Description
1	VDD	Power Supply	Power Supply (+9.9V)
2	GND	Power Supply	Power Ground

**Backlight connector:** JST p/n: BHSR-02VS-1

**Recommended mating connector:** JST p/n: SM 02B-BHSS-1

## Touch Panel Pin-Out:

Pin No.	Symbol	Connection	Function Description
1	X-	Touch Panel	Touch Panel – RIGHT
2	Y-	Touch Panel	Touch Panel – BOTTOM
3	X+	Touch Panel	Touch Panel – LEFT
4	Y+	Touch Panel	Touch Panel – TOP

## Touch Panel Characteristics

Item	Min.	Typ.	Max.	Unit
Linearity	-	-	1.5	%
Circuit Resistance – X-Axis	450	800	1300	$\Omega$
Circuit Resistance – Y-Axis	100	350	800	$\Omega$
Insulation Resistance	10	-	-	M $\Omega$
Operating Voltage	-	-	5	V
Chattering	-	-	10	ms
Transmittance	82	-	-	%
Activation Force	50	-	200	g
Pen Writing Durability	100,000	-	-	Characters
Pitting Durability	1,000,000	-	-	Touches
Surface Hardness	3	-	-	H
Haze	-	7	-	%

## Electrical Characteristics

Item	Symbol	Condition	Min.	Typ.	Max.	Unit
Operating Temperature Range	Top	Absolute Max	-20	-	+70	$^{\circ}\text{C}$
Storage Temperature Range	Tst	Absolute Max	-30	-	+80	$^{\circ}\text{C}$
Supply Voltage	VDD		3.0	3.3	3.5	V
Supply Current	IDD	VDD=3.3V 25 $^{\circ}\text{C}$	-	200	260	mA
"H" Level input	Vih		0.8VDD	-	VDD+ 0.5	V
"L" Level input	Vil		-	-	0.2VDD	V
Backlight Supply Voltage	VLED		-	9.9	-	V
Backlight Supply Current	ILED	VLED=9.9V	140	160	180	mA
Backlight Lifetime	-	Until half-brightness	10,000	20,000	-	Hrs.

## Optical Characteristics

Item	Symbol	Condition	Min.	Typ.	Max.	Unit
Viewing Angle –Vertical (Top)	AV	Cr $\geq$ 10	50	60	-	$^{\circ}$
Viewing Angle –Vertical (Bottom)	AV	Cr $\geq$ 10	60	70	-	$^{\circ}$
Viewing Angle – Horizontal (Left)	AH	Cr $\geq$ 10	60	70	-	$^{\circ}$
Viewing Angle – Horizontal (Right)	AH	Cr $\geq$ 10	60	70	-	$^{\circ}$
Contrast Ratio	Cr	-	250	400	-	-
Luminance	YL	-	300	350	-	cd/m $^2$
Response Time (rise)	Tr	-	-	5	10	ms
Response Time (fall)	Tf	-	-	11	16	ms

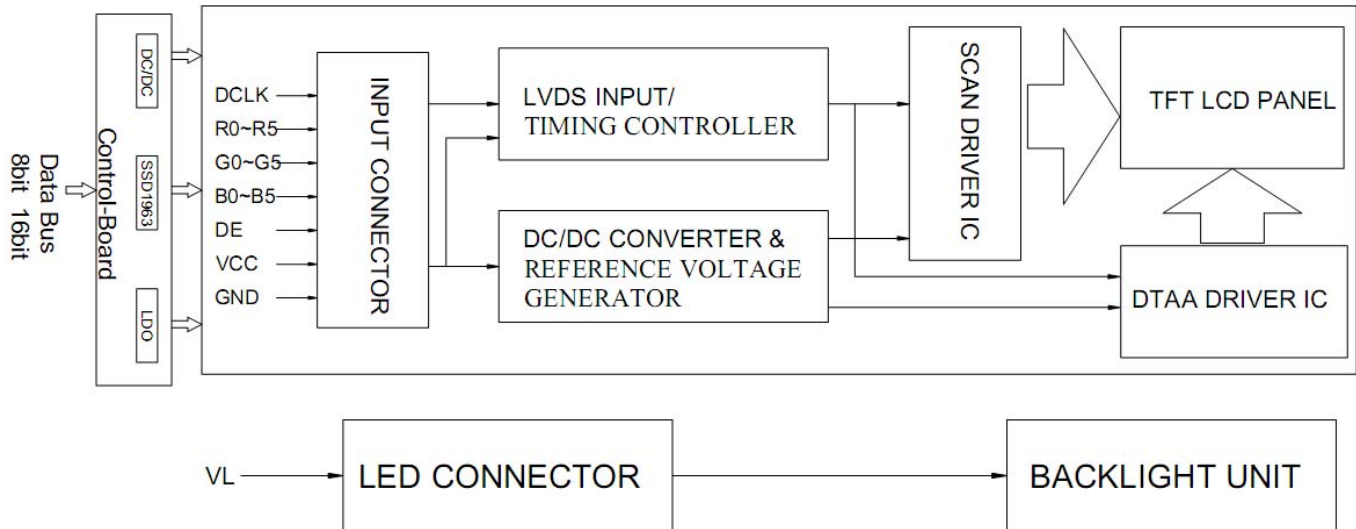

## Controller Information

Built-in SSD1963 controller.

Please download specification at [http://www.newhavendisplay.com/app\\_notes/SSD1963.pdf](http://www.newhavendisplay.com/app_notes/SSD1963.pdf)

## Parallel Interface:

The SSD1963 controller supports both 8080 mode and 6800 mode.

See the SSD1963 datasheet for detailed timing diagrams.

## Command Instructions:

See the SSD1963 datasheet for the Instruction Table and Command Descriptions.

## Pixel Data Format:

Interface	Cycle	D[7]	D[6]	D[5]	D[4]	D[3]	D[2]	D[1]	D[0]
8 bits	1 <sup>st</sup>	R7	R6	R5	R4	R3	R2	R1	R0
	2 <sup>nd</sup>	G7	G6	G5	G4	G3	G2	G1	G0
	3 <sup>rd</sup>	B7	B6	B5	B4	B3	B2	B1	B0

## Example Initialization Code

```
/******  
* Function Name : UILCD_Init  
* Description  : Initializes LCD.  
* Input       : None  
* Output      : None  
* Return      : None  
*****/  
void TFT_7_Init(void)  
{  
    GPIO_ResetBits(GPIOC, CS1);  
    GPIO_SetBits(GPIOC, nRD);  
    GPIO_ResetBits(GPIOC, nWR);  
    GPIO_WriteBit(GPIOC, RES, Bit_RESET);  
    TFT_delay(5);  
    GPIO_WriteBit(GPIOC, RES, Bit_SET);  
    TFT_delay(100);  
    TFT_7_Write_Command(0x01); //Software Reset  
    TFT_7_Write_Command(0x01);  
    TFT_7_Write_Command(0x01);  
    TFT_delay(10);  
    TFT_7_Command_Write(0xe0,0x01); //START PLL  
    TFT_7_Command_Write(0xe0,0x03); //LOCK PLL  
    TFT_7_Write_Command(0xb0); //SET LCD MODE SET TFT 18Bits MODE  
    GPIO_SetBits(GPIOC, RS);  
    TFT_7_Write_Data(0x08); //SET TFT MODE & hsync+Vsync+DEN MODE  
    TFT_7_Write_Data(0x80); //SET TFT MODE & hsync+Vsync+DEN MODE  
    TFT_7_Write_Data(0x03); //SET horizontal size=800-1 HighByte  
    TFT_7_Write_Data(0x1f); //SET horizontal size=800-1 LowByte  
    TFT_7_Write_Data(0x01); //SET vertical size=480-1 HighByte  
    TFT_7_Write_Data(0xdf); //SET vertical size=480-1 LowByte  
    TFT_7_Write_Data(0x00); //SET even/odd line RGB seq.=RGB  
    TFT_7_Command_Write(0xf0,0x00); //SET pixel data I/F format=8bit  
    TFT_7_Command_Write(0x36,0x09); //SET address mode=flip vertical, BGR  
    TFT_7_Command_Write(0x3a,0x60); //SET R G B format = 6 6 6  
    TFT_7_Write_Command(0xe2); //SET PLL freq=113.33MHz  
    GPIO_SetBits(GPIOC, RS);  
    TFT_7_Write_Data(0x22);  
    TFT_7_Write_Data(0x03);  
    TFT_7_Write_Data(0x04);  
    TFT_7_Write_Command(0xe6); //SET PCLK freq=33.26MHz  
    GPIO_SetBits(GPIOC, RS);  
    TFT_7_Write_Data(0x02);  
    TFT_7_Write_Data(0xff);  
    TFT_7_Write_Data(0xff);  
    TFT_7_Write_Command(0xb4); //SET HBP,  
    GPIO_SetBits(GPIOC, RS);  
    TFT_7_Write_Data(0x03); //SET HSYNC Total  
    TFT_7_Write_Data(0xef);  
    TFT_7_Write_Data(0x00); //SET HBP  
    TFT_7_Write_Data(0xa3);  
    TFT_7_Write_Data(0x07); //SET VBP  
    TFT_7_Write_Data(0x00); //SET Hsync pulse start position  
    TFT_7_Write_Data(0x00);  
    TFT_7_Write_Data(0x00); //SET Hsync pulse subpixel start position  
    TFT_7_Write_Command(0xb6); //SET VBP,
```



```

GPIO_SetBits(GPIOC, RS);
TFT_7_Write_Data(0x01);           //SET Vsync total = 496
TFT_7_Write_Data(0xef);
TFT_7_Write_Data(0x00);           //SET VBP=4
TFT_7_Write_Data(0x04);
TFT_7_Write_Data(0x01);           //SET Vsync pulse 2=1+1
TFT_7_Write_Data(0x00);           //SET Vsync pulse start position
TFT_7_Write_Data(0x00);
TFT_7_Write_Command(0x2a);        //SET column address
GPIO_SetBits(GPIOC, RS);
TFT_7_Write_Data(0x00);           //SET start column address=0
TFT_7_Write_Data(0x00);
TFT_7_Write_Data(0x03);           //SET end column address=799
TFT_7_Write_Data(0x1f);
TFT_7_Write_Command(0x2b);        //SET page address
GPIO_SetBits(GPIOC, RS);
TFT_7_Write_Data(0x00);           //SET start page address=0
TFT_7_Write_Data(0x00);
TFT_7_Write_Data(0x01);           //SET end page address=479
TFT_7_Write_Data(0xdf);
/*TFT_7_Write_Command(0x33);      //SET scroll area
GPIO_SetBits(GPIOC, RS);
TFT_7_Write_Data(0x00);           //SET top fixed area=0
TFT_7_Write_Data(0x00);
TFT_7_Write_Data(0x01);           //SET vertical scrolling area=479
TFT_7_Write_Data(0xdf);
TFT_7_Write_Data(0x00);           //SET bottom fixed area=0
TFT_7_Write_Data(0x00);
TFT_7_Write_Command(0x28);        //SET display off */
}

```

```
void TFT_7_Write_Command(unsigned char command)
```

```

{
GPIO_Write(GPIOB, command);
GPIO_ResetBits(GPIOC, RS);
GPIO_ResetBits(GPIOC, nWR);
GPIO_SetBits(GPIOC, nWR);
}

```

```
void TFT_7_Write_Data(unsigned char data1)
```

```

{
GPIO_SetBits(GPIOC, RS);
GPIO_Write(GPIOB, data1);
GPIO_ResetBits(GPIOC, nWR);
GPIO_SetBits(GPIOC, nWR);
}

```

```
void TFT_7_Command_Write(unsigned char REG,unsigned char VALUE)
```

```

{
TFT_7_Write_Command(REG);
TFT_7_Write_Data(VALUE);
}

```

```
void TFT_7_SendData(unsigned long color)
```

```

{
GPIO_SetBits(GPIOC, RS);
GPIO_Write(GPIOB, (color>>16));
GPIO_ResetBits(GPIOC, nWR);
}

```

```
GPIO_SetBits(GPIOC, nWR);
GPIO_Write(GPIOB, (color>>8));
GPIO_ResetBits(GPIOC, nWR);
GPIO_SetBits(GPIOC, nWR);
GPIO_Write(GPIOB, (color));
GPIO_ResetBits(GPIOC, nWR);
GPIO_SetBits(GPIOC, nWR);
}
```

```
void TFT_7_WindowSet(unsigned int s_x,unsigned int e_x,unsigned int s_y,unsigned int e_y)
```

```
{
TFT_7_Write_Command(0x2a);           //SET page address
TFT_7_Write_Data((s_x)>>8);          //SET start page address=0
TFT_7_Write_Data(s_x);
TFT_7_Write_Data((e_x)>>8);          //SET end page address=639
TFT_7_Write_Data(e_x);

TFT_7_Write_Command(0x2b);           //SET column address
TFT_7_Write_Data((s_y)>>8);          //SET start column address=0
TFT_7_Write_Data(s_y);
TFT_7_Write_Data((e_y)>>8);          //SET end column address=479
TFT_7_Write_Data(e_y);
}
```

## Quality Information

Test Item	Content of Test	Test Condition	Note
High Temperature storage	Endurance test applying the high storage temperature for a long time.	+80°C , 240hrs	2
Low Temperature storage	Endurance test applying the low storage temperature for a long time.	-30°C , 240hrs	1,2
High Temperature Operation	Endurance test applying the electric stress (voltage & current) and the high thermal stress for a long time.	+70°C 240hrs	2
Low Temperature Operation	Endurance test applying the electric stress (voltage & current) and the low thermal stress for a long time.	-20°C , 240hrs	1,2
High Temperature / Humidity Operation	Endurance test applying the electric stress (voltage & current) and the high thermal with high humidity stress for a long time.	+60°C , 90% RH , 240hrs	1,2
Thermal Shock resistance	Endurance test applying the electric stress (voltage & current) during a cycle of low and high thermal stress.	-30°C,30min -> 25°C,5min ->80°C,30min = 1 cycle 10 cycles	
Vibration test	Endurance test applying vibration to simulate transportation and use.	10-55Hz , 15mm amplitude. 60 sec in each of 3 directions X,Y,Z For 15 minutes	3
Static electricity test	Endurance test applying electric static discharge.	VS=800V, RS=1.5kΩ, CS=100pF One time	

**Note 1:** No condensation to be observed.

**Note 2:** Conducted after 4 hours of storage at 25°C, 0%RH.

**Note 3:** Test performed on product itself, not inside a container.

## Precautions for using LCDs/LCMs

See Precautions at [www.newhavendisplay.com/specs/precautions.pdf](http://www.newhavendisplay.com/specs/precautions.pdf)

## Warranty Information and Terms & Conditions

[http://www.newhavendisplay.com/index.php?main\\_page=terms](http://www.newhavendisplay.com/index.php?main_page=terms)



## Стандарт Электрон Связь

Мы молодая и активно развивающаяся компания в области поставок электронных компонентов. Мы поставляем электронные компоненты отечественного и импортного производства напрямую от производителей и с крупнейших складов мира.

Благодаря сотрудничеству с мировыми поставщиками мы осуществляем комплексные и плановые поставки широчайшего спектра электронных компонентов.

Собственная эффективная логистика и склад в обеспечивает надежную поставку продукции в точно указанные сроки по всей России.

Мы осуществляем техническую поддержку нашим клиентам и предпродажную проверку качества продукции. На все поставляемые продукты мы предоставляем гарантию .

Осуществляем поставки продукции под контролем ВП МО РФ на предприятия военно-промышленного комплекса России , а также работаем в рамках 275 ФЗ с открытием отдельных счетов в уполномоченном банке. Система менеджмента качества компании соответствует требованиям ГОСТ ISO 9001.

Минимальные сроки поставки, гибкие цены, неограниченный ассортимент и индивидуальный подход к клиентам являются основой для выстраивания долгосрочного и эффективного сотрудничества с предприятиями радиоэлектронной промышленности, предприятиями ВПК и научно-исследовательскими институтами России.

С нами вы становитесь еще успешнее!

### Наши контакты:

**Телефон:** +7 812 627 14 35

**Электронная почта:** [sales@st-electron.ru](mailto:sales@st-electron.ru)

**Адрес:** 198099, Санкт-Петербург,  
Промышленная ул, дом № 19, литера Н,  
помещение 100-Н Офис 331