

NLX2G66

Dual Bilateral Analog Switch / Digital Multiplexer

The NLX2G66 is a dual single pole, single throw (SPST) analog switch / digital multiplexer. This single supply voltage IC is designed with a sub-micron CMOS technology to provide low propagation delays (t_{pd}) and ON resistance (R_{ON}), while maintaining low power dissipation. This bi-lateral switch can be used with either analog or digital signals that may vary across the full power supply range from V_{CC} to GND.

Features

- Wide V_{CC} Operating Range: 1.65 V to 5.5 V
- OVT up to +5.5 V for Control Pin
- R_{ON} : Typically $< 5 \Omega$ at $V_{CC} = 4.5$ V and $I_S = 32$ mA
- Rail-to-Rail Input/Output
- High Speed, Typical $t_{PD} < 1$ ns at $V_{CC} = 4.5$ V and $C_L = 50$ pF
- High On-Off Output Voltage Ratio
- High Degree of Linearity
- Ultra-Small Pb-Free, Halide-Free, RoHS-Compliant Packages
- ESD Performance: > 5000 V HBM, > 400 V MM

Typical Applications

- Cell Phones, PDAs, MP3 and other Portable Media Players

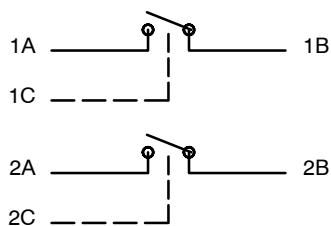

Figure 1. Analog Symbol

PIN ASSIGNMENTS

UDFN8	UQFN8-0.5P	Description
1	7	1A
2	6	1B
3	5	2C
4	4	GND
5	3	2A
6	2	2B
7	1	1C
8	8	V_{CC}

This document contains information on a product under development. ON Semiconductor reserves the right to change or discontinue this product without notice.



ON Semiconductor®

<http://onsemi.com>

MARKING DIAGRAMS

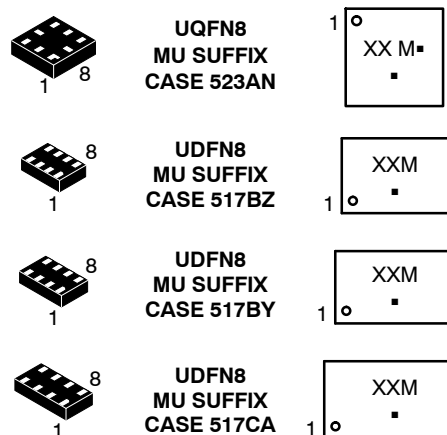

- XX = Specific Device Code
- M = Date Code
- = Pb-Free Package

(*Note: Microdot may be in either location)

PIN ASSIGNMENTS

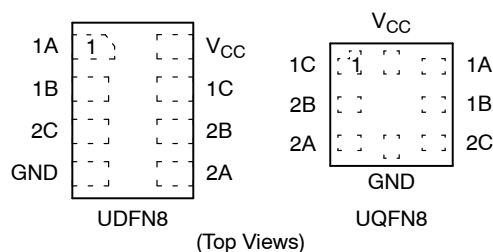

FUNCTION TABLE

Control Input (C)	Switch
L	OFF
H	ON

ORDERING INFORMATION

See detailed ordering and shipping information in the package dimensions section on page 5 of this data sheet.

NLX2G66

Table 1. MAXIMUM RATINGS

Symbol	Rating	Value	Unit
V_{CC}	Positive DC Supply Voltage	-0.5 to +7.0	V
V_S	Switch Input / Output Voltage (Pins 1A, 1B, 2A and 2B)	-0.5 to + V_{CC} + 0.5	V
V_I	Digital Control Input Voltage (Pins 1C and 2C)	-0.5 to +7.0	V
I_{OK}	I/O port diode current	±50	mA
I_{IK}	Control input diode current	-50	mA
$I_{I/O}$	Continuous DC Current Through Analog Switch	±100	mA
I_L	Latch-up Current, (Above V_{CC} and below GND at 125°C)	±100	mA
T_s	Storage Temperature	-65 to +150	°C
V_{ESD}	ESD Withstand Voltage: Human Body Model (HBM) Machine Model (MM)	≥ 5000 > 400	V

Stresses exceeding Maximum Ratings may damage the device. Maximum Ratings are stress ratings only. Functional operation above the Recommended Operating Conditions is not implied. Extended exposure to stresses above the Recommended Operating Conditions may affect device reliability.

Table 2. RECOMMENDED OPERATING CONDITIONS

Symbol	Parameter	Min	Max	Unit	
V_{CC}	Positive DC Supply Voltage	1.65	5.5	V	
V_S	Switch Input / Output Voltage (Pins 1A, 2A, 1B and 2B)	GND	V_{CC}	V	
V_I	Digital Control Input Voltage (Pins 1C and 2C)	GND	5.5	V	
T_A	Operating Temperature Range	-55	+125	°C	
t_r, t_f	Input Transition Rise or Fall Time (ON/OFF Control Input)	$V_{CC} = < 3.0$ V	0	20	ns/V
		$V_{CC} = \geq 3.0$ V	0	10	

Table 3. ELECTRICAL CHARACTERISTICS

Symbol	Parameter	Condition	V_{CC}	Guaranteed Limit				Unit
				25°C		-55° to 125°C		
				Min	Max	Min	Max	
V_{IH}	High-Level Input Voltage, Control Input		1.65 to 1.95			$V_{CC} \times 0.65$		V
			2.3 to 5.5			$V_{CC} \times 0.7$		
V_{IL}	Low-Level Input Voltage, Control Input		1.65 to 1.95			$V_{CC} \times 0.35$		V
			2.3 to 5.5			$V_{CC} \times 0.30$		
I_I	Input Leakage Current, Control Input	$V_I = V_{CC}$ or GND	5.5		±0.1		±1	µA
$I_{S(ON)}$	ON-State Switch Leakage Current	$V_{IS} = V_{CC}$ or GND, $V_I = V_{IH}$, $V_{OS} = \text{Open}$	5.5		±0.1		±1	µA
$I_{S(OFF)}$	OFF-State Switch Leakage Current	$V_{IS} = V_{CC}$ and $V_{OS} = \text{GND}$, or $V_{IS} = \text{GND}$ and $V_{OS} = V_{CC}$ GND, $V_I = V_{IL}$.	5.5		±0.1		±1	µA
I_{CC}	Quiescent Supply Current	$V_I = V_{CC}$ or GND	5.5		1.0		10	µA
ΔI_{CC}	Supply Current Change	$V_I = V_{CC} - 0.6$	5.5				500	µA
C_I	Control Input Capacitance		5				3.0	pF
$C_{I/O(Off)}$	Switch OFF Input / Output Capacitance	See Figure 3	5				6.0	pF
$C_{I/O(On)}$	Switch ON Input / Output Capacitance	See Figure 4	5				13	pF

NLX2G66

Table 4. SWITCHING CHARACTERISTICS

Symbol	Parameter	Condition	V _{CC}	Guaranteed Limit		Unit
				-55° to 125°C		
				Min	Max	
t _{PLH} , t _{PHL}	Propagation Delay, A to B, B to A	C _L = 30 pF, R _L = 1 kΩ	1.8		6.5	ns
			2.5		3.3	
		C _L = 50 pF, R _L = 500 Ω	3.3		2.5	
			5.0		2.2	
T _{EN} (t _{PZL} , t _{PHZ})	Enable Time, C to Analog Output (A or B)	C _L = 50 pF, R _L = 500 Ω See Figure 6	1.8		10	ns
			2.5		6.5	
			3.3		5.5	
			5.0		4.9	
T _{DIS} (t _{PLZ} , t _{PHZ})	Disable Time, C to Analog Output (A or B)	C _L = 50 pF, R _L = 500 Ω See Figure 6	1.8		9.0	ns
			2.5		7.2	
			3.3		6.5	
			5.0		6.0	

Table 5. ANALOG SWITCH CHARACTERISTICS

Symbol	Parameter	Conditions	V _{CC}	25°C	-55° to 125°C		Unit	
				Typ	Min	Max		
R _{ON}	On-Resistance	V _{IS} = V _{CC} or GND, V _I = V _{IH} , See Figure 2	I _S = 4 ma	1.65	12		30	Ω
			I _S = 8 ma	2.3	9		20	
			I _S = 24 ma	3.0	7.5		15	
			I _S = 32 ma	4.5	5.5		13	
R _{ON(peak)}	Peak On-Resistance	V _{IS} = GND to V _{CC} ; V _I = V _{IH} , See Figure 2	I _S = 4 ma	1.65	74.5		220	Ω
			I _S = 8 ma	2.3	20		75	
			I _S = 24 ma	3.0	11.5		25	
			I _S = 32 ma	4.5	7.5		17	
ΔR _{ON}	On-Resistance Mismatch between Switches	V _{IS} = GND to V _{CC} ; V _I = V _{IH} , See Figure 2	I _S = 4 ma	1.65			8.0	Ω
			I _S = 8 ma	2.3			5.0	
			I _S = 24 ma	3.0			3.0	
			I _S = 32 ma	4.5			2.0	
BW	Bandwidth (f _{-3dB})	R _L = 50 Ω, C _L = 5 pF, f _{IN} = Sine Wave See Figure 8	1.65				> 270	MHz
			2.3				> 270	
			3.0				> 270	
			4.5				> 270	

NLX2G66

Table 5. ANALOG SWITCH CHARACTERISTICS (continued)

Symbol	Parameter	Conditions	V _{CC}	25°C	Unit
				Typ	
ISO _{Off}	Off-Channel Feedthrough Isolation	R _L = 600 Ω, C _L = 50 pF, f _{IN} = 1 MHz Sine Wave See Figure 9	1.65	-70	dB
			2.3	-70	
			3.0	-70	
			4.5	-70	
		R _L = 50 Ω, C _L = 5 pF, f _{IN} = 1 MHz Sine Wave See Figure 9	1.65	-60	
			2.3	-60	
			3.0	-60	
			4.5	-60	
XTalk	Crosstalk Between Switches	R _L = 600 Ω, C _L = 50 pF, f _{IN} = 1 MHz Sine Wave See Figure 10	1.65	-100	dB
			2.3	-100	
			3.0	-100	
			4.5	-100	
		R _L = 50 Ω, C _L = 5 pF, f _{IN} = 1 MHz Sine Wave See Figure 10	1.65	-90	
			2.3	-90	
			3.0	-90	
			4.5	-90	
	Feedthrough Noise, Control to Switch	R _L = 600 Ω, C _L = 50 pF, f _{IN} = 1 MHz Square Wave, t _r = t _f = 2 ns, See Figure 11	1.65	10	mV _{pp}
			2.3	10	
			3.0	10	
			4.5	15	
THD	Total Harmonic Distortion	C _L = 50 pF, R _L = 50 Ω, f _{IN} = 600 Hz to 20 KHz Sine Wave, See Figure 12	2.3	0.025	%
			3.0	0.015	
			4.5	0.01	

Table 6. POWER DISSIPATION CHARACTERISTICS

Symbol	Parameter	Conditions	V _{CC}	25°C	Unit
				Typ	
C _{PD}	Power Dissipation Capacitance	f = 10 MHz	1.65	8.0	pF
			2.3	8.9	
			3.0	9.6	
			4.5	10.9	

NLX2G66

Table 7. DEVICE ORDERING INFORMATION

Device Order Number	Package	Shipping†
NLX2G66AMUTCG (In Development)	UQFN8-0.5P, 1.6 mm x 1.6 mm (Pb-Free)	3000 / Tape & Reel
NLX2G66DMUTAG	UDFN8-0.5P, 1.95 mm x 1.0 mm (Pb-Free)	3000 / Tape & Reel
NLX2G66DMUTCG	UDFN8-0.5P, 1.95 mm x 1.0 mm (Pb-Free)	3000 / Tape & Reel
NLX2G66EMUTCG (In Development)	UDFN8-0.4P, 1.6 mm x 1.0 mm (Pb-Free)	3000 / Tape & Reel
NLX2G66FMUTCG (In Development)	UDFN8-0.35P, 1.45 mm x 1.0 mm (Pb-Free)	3000 / Tape & Reel

†For information on tape and reel specifications, including part orientation and tape sizes, please refer to our Tape and Reel Packaging Specifications Brochure, BRD8011/D.

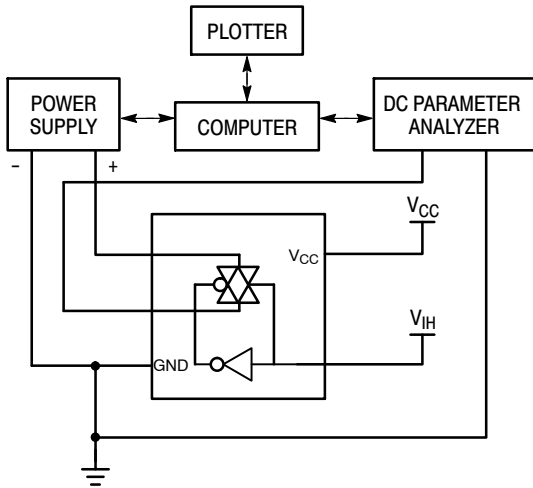

Figure 2. On Resistance Test Set-Up

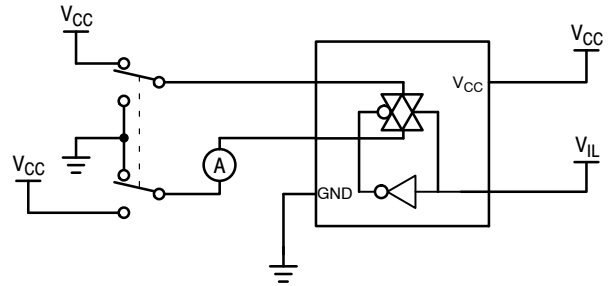

Figure 3. Maximum Off-Channel Leakage Current Test Set-Up

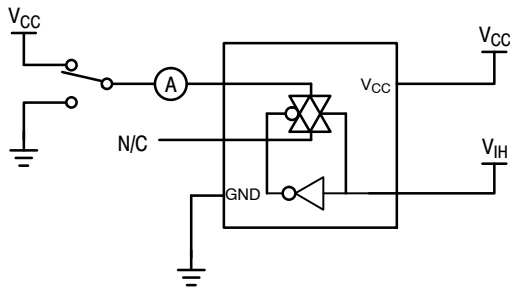

Figure 4. Maximum On-Channel Leakage Current Test Set-Up

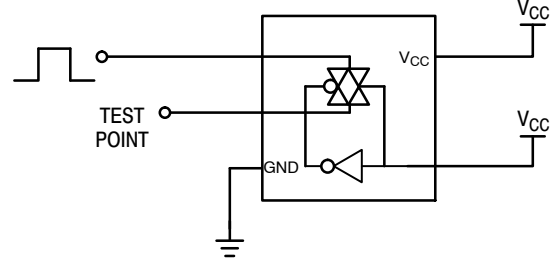

Figure 5. Propagation Delay Test Set-Up

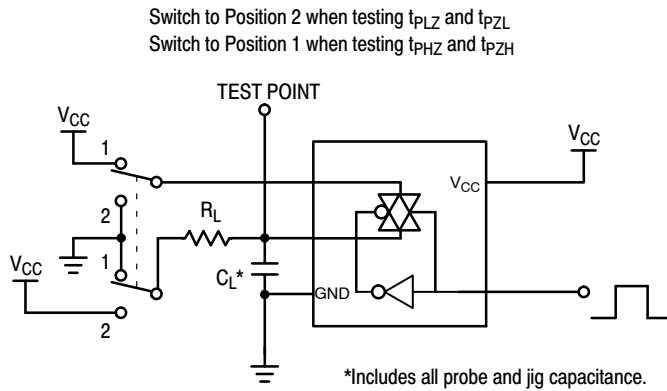

Figure 6. Propagation Delay Output Enable/Disable Test Set-Up

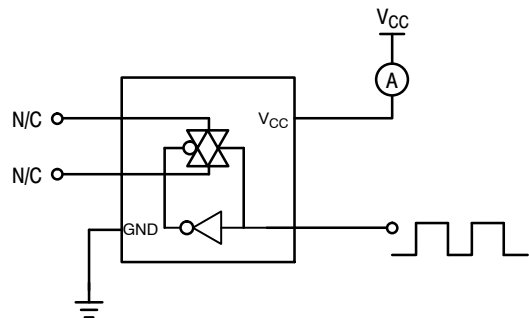

Figure 7. Power Dissipation Capacitance Test Set-Up

NLX2G66

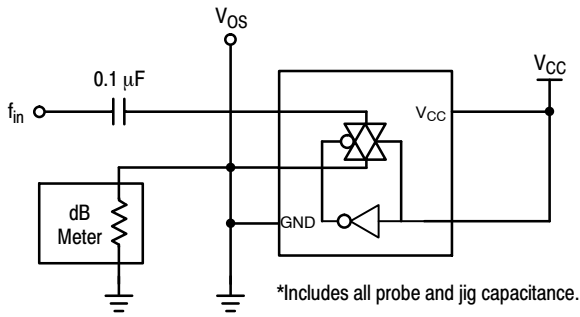

Figure 8. Maximum On-Channel Bandwidth Test Set-Up

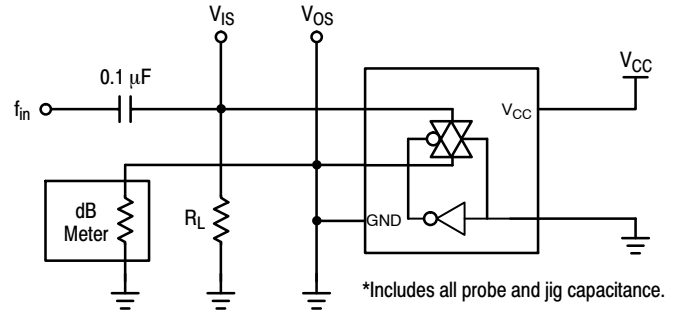

Figure 9. Off-Channel Feedthrough Isolation Test Set-Up

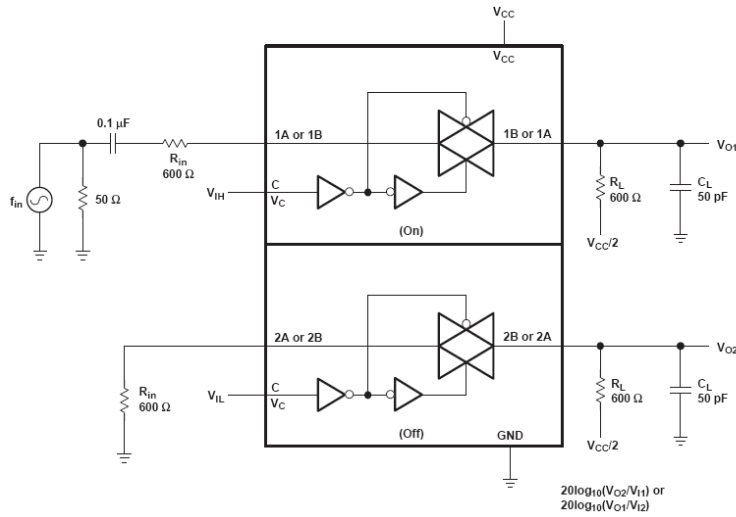

Figure 10. Crosstalk (between Switches)

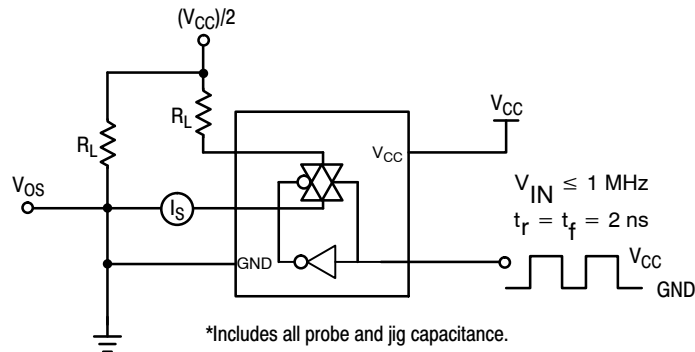

Figure 11. Feedthrough Noise, ON/OFF Control to Analog Out, Test Set-Up

NLX2G66

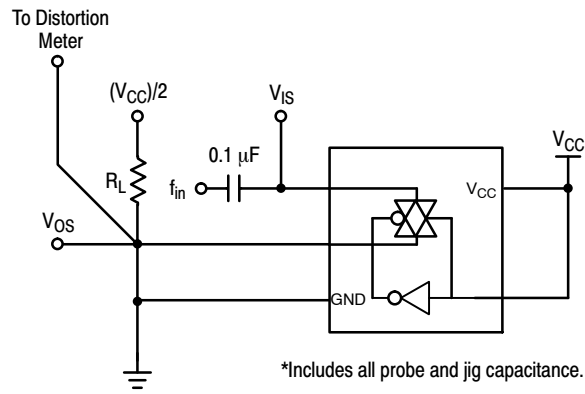

Figure 12. Total Harmonic Distortion Test Set-Up

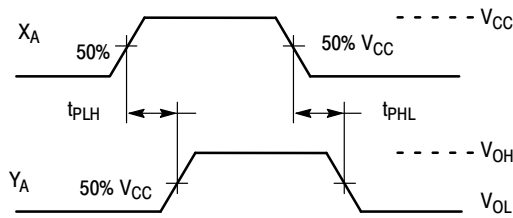

Figure 13. Propagation Delay, Analog In to Analog Out Waveforms

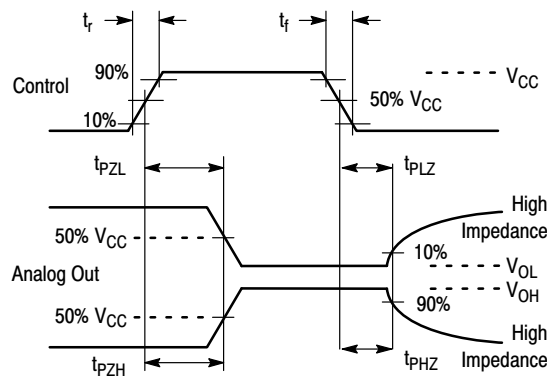
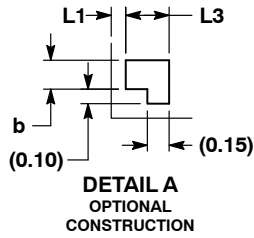
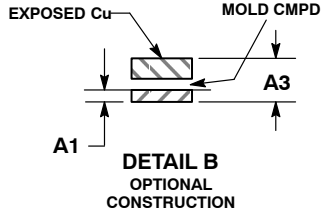
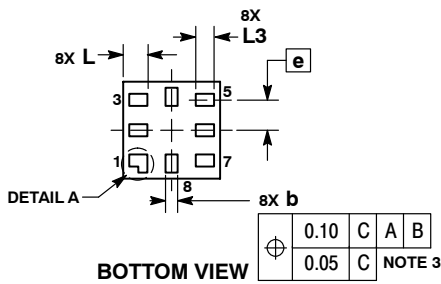
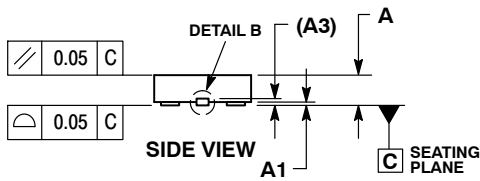
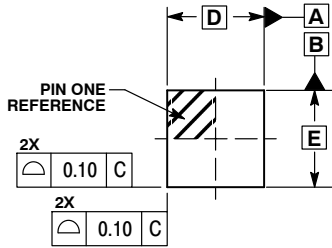

Figure 14. Propagation Delay, ON/OFF Control

NLX2G66

PACKAGE DIMENSIONS

UQFN8 MU SUFFIX CASE 523AN ISSUE O



NOTES:

1. DIMENSIONING AND TOLERANCING PER ASME Y14.5M, 1994.
2. CONTROLLING DIMENSION: MILLIMETERS.
3. DIMENSION b APPLIES TO PLATED TERMINAL AND IS MEASURED BETWEEN 0.15 AND 0.30 mm FROM THE TERMINAL TIP.

MILLIMETERS		
DIM	MIN	MAX
A	0.45	0.60
A1	0.00	0.05
A3	0.13	REF
b	0.15	0.25
D	1.60	BSC
E	1.60	BSC
e	0.50	BSC
L	0.35	0.45
L1	---	0.15
L3	0.25	0.35

SOLDERING FOOTPRINT*

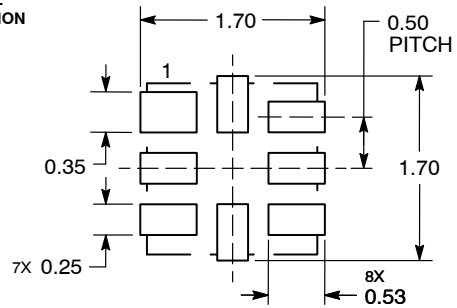

DIMENSIONS: MILLIMETERS

*For additional information on our Pb-Free strategy and soldering details, please download the ON Semiconductor Soldering and Mounting Techniques Reference Manual, SOLDERRM/D.

NLX2G66

PACKAGE DIMENSIONS

UDFN8 1.6x1.0, 0.4P
CASE 517BY
ISSUE O

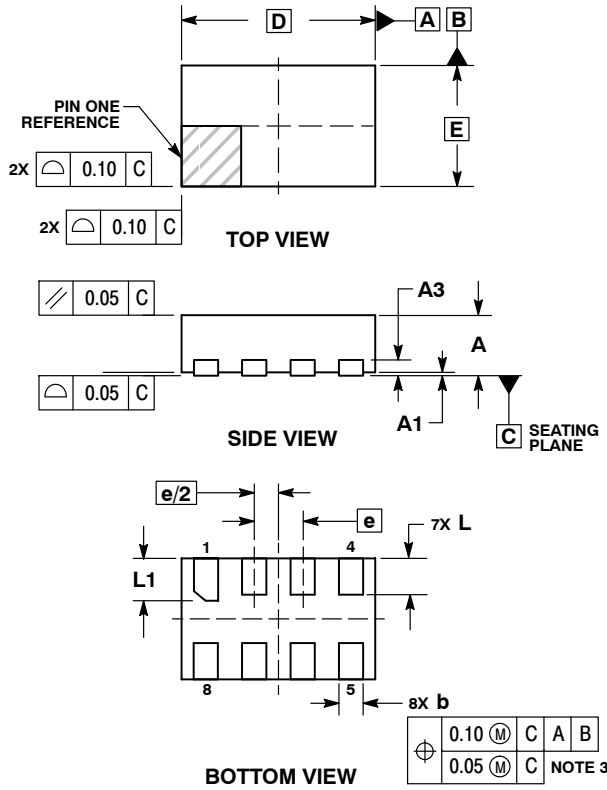

NOTES:

1. DIMENSIONING AND TOLERANCING PER ASME Y14.5M, 1994.
2. CONTROLLING DIMENSION: MILLIMETERS.
3. DIMENSION b APPLIES TO PLATED TERMINAL AND IS MEASURED BETWEEN 0.15 AND 0.20 MM FROM TERMINAL TIP.
4. PACKAGE DIMENSIONS EXCLUSIVE OF BURRS AND MOLD FLASH.

DIM	MILLIMETERS	
	MIN	MAX
A	0.45	0.55
A1	0.00	0.05
A3	0.13	REF
b	0.15	0.25
D	1.60	BSC
E	1.00	BSC
e	0.40	BSC
L	0.25	0.35
L1	0.30	0.40

RECOMMENDED SOLDERING FOOTPRINT*

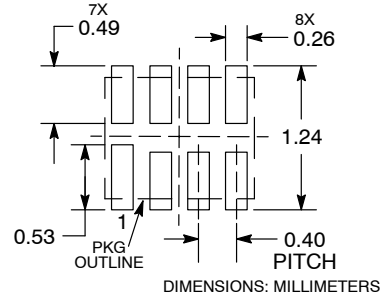

*For additional information on our Pb-Free strategy and soldering details, please download the ON Semiconductor Soldering and Mounting Techniques Reference Manual, SOLDERRM/D.

NLX2G66

PACKAGE DIMENSIONS

UDFN8 1.45x1.0, 0.35P
CASE 517BZ
ISSUE O

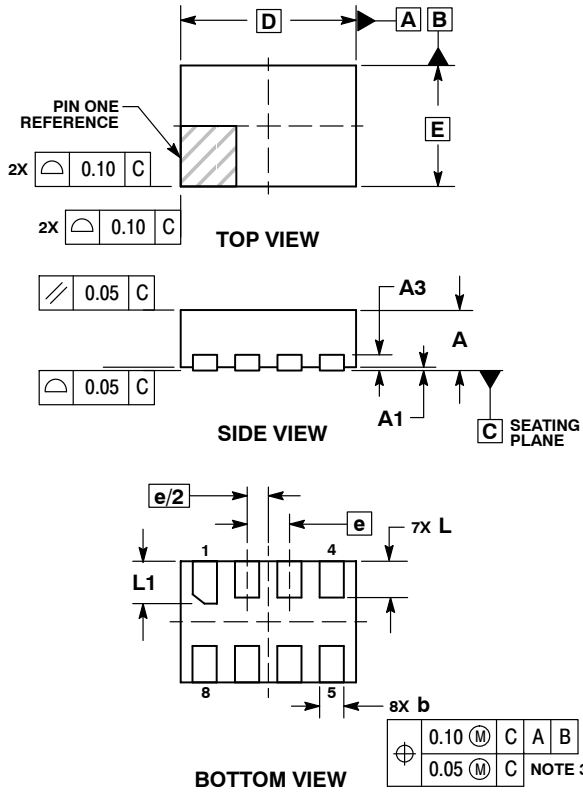

NOTES:

1. DIMENSIONING AND TOLERANCING PER ASME Y14.5M, 1994.
2. CONTROLLING DIMENSION: MILLIMETERS.
3. DIMENSION b APPLIES TO PLATED TERMINAL AND IS MEASURED BETWEEN 0.15 AND 0.20 MM FROM TERMINAL TIP.
4. PACKAGE DIMENSIONS EXCLUSIVE OF BURRS AND MOLD FLASH.

DIM	MILLIMETERS	
	MIN	MAX
A	0.45	0.55
A1	0.00	0.05
A3	0.13	REF
b	0.15	0.25
D	1.45	BSC
E	1.00	BSC
e	0.35	BSC
L	0.25	0.35
L1	0.30	0.40

RECOMMENDED SOLDERING FOOTPRINT*

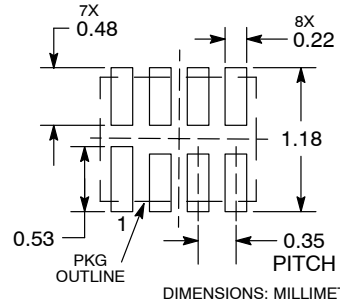

*For additional information on our Pb-Free strategy and soldering details, please download the ON Semiconductor Soldering and Mounting Techniques Reference Manual, SOLDERRM/D.

NLX2G66

PACKAGE DIMENSIONS

UDFN8 1.95x1.0, 0.5P
CASE 517CA
ISSUE O

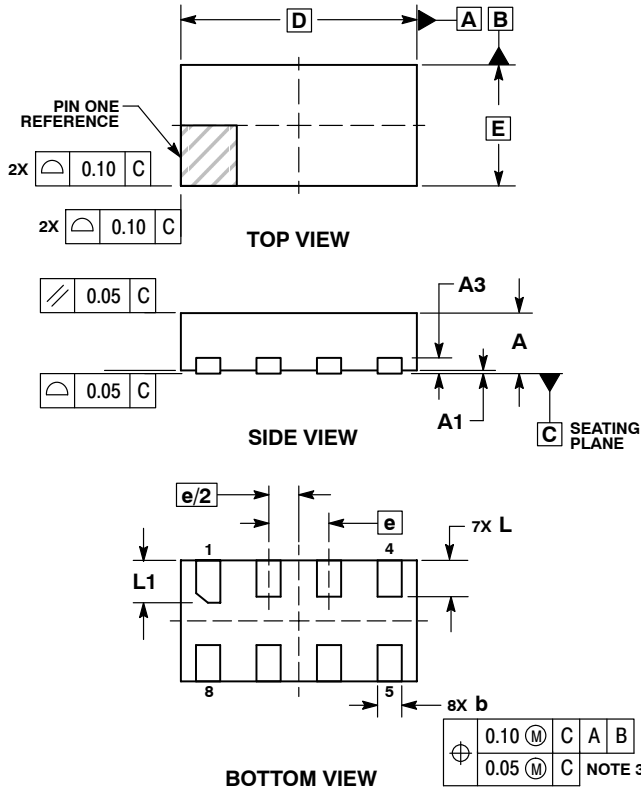

NOTES:

1. DIMENSIONING AND TOLERANCING PER ASME Y14.5M, 1994.
2. CONTROLLING DIMENSION: MILLIMETERS.
3. DIMENSION b APPLIES TO PLATED TERMINAL AND IS MEASURED BETWEEN 0.15 AND 0.20 MM FROM TERMINAL TIP.
4. PACKAGE DIMENSIONS EXCLUSIVE OF BURRS AND MOLD FLASH.

MILLIMETERS		
DIM	MIN	MAX
A	0.45	0.55
A1	0.00	0.05
A3	0.13 REF	
b	0.15	0.25
D	1.95 BSC	
E	1.00 BSC	
e	0.50 BSC	
L	0.25	0.35
L1	0.30	0.40

RECOMMENDED SOLDERING FOOTPRINT*

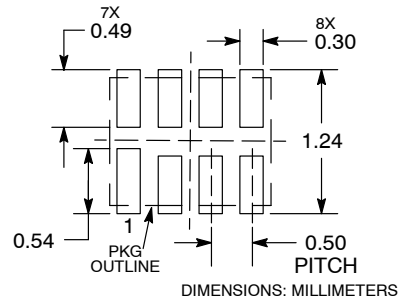

*For additional information on our Pb-Free strategy and soldering details, please download the ON Semiconductor Soldering and Mounting Techniques Reference Manual, SOLDERRM/D.

ON Semiconductor and are registered trademarks of Semiconductor Components Industries, LLC (SCILLC). SCILLC owns the rights to a number of patents, trademarks, copyrights, trade secrets, and other intellectual property. A listing of SCILLC's product/patent coverage may be accessed at www.onsemi.com/site/pdf/Patent-Marking.pdf. SCILLC reserves the right to make changes without further notice to any products herein. SCILLC makes no warranty, representation or guarantee regarding the suitability of its products for any particular purpose, nor does SCILLC assume any liability arising out of the application or use of any product or circuit, and specifically disclaims any and all liability, including without limitation special, consequential or incidental damages. "Typical" parameters which may be provided in SCILLC data sheets and/or specifications can and do vary in different applications and actual performance may vary over time. All operating parameters, including "Typicals" must be validated for each customer application by customer's technical experts. SCILLC does not convey any license under its patent rights nor the rights of others. SCILLC products are not designed, intended, or authorized for use as components in systems intended for surgical implant into the body, or other applications intended to support or sustain life, or for any other application in which the failure of the SCILLC product could create a situation where personal injury or death may occur. Should Buyer purchase or use SCILLC products for any such unintended or unauthorized application, Buyer shall indemnify and hold SCILLC and its officers, employees, subsidiaries, affiliates, and distributors harmless against all claims, costs, damages, and expenses, and reasonable attorney fees arising out of, directly or indirectly, any claim of personal injury or death associated with such unintended or unauthorized use, even if such claim alleges that SCILLC was negligent regarding the design or manufacture of the part. SCILLC is an Equal Opportunity/Affirmative Action Employer. This literature is subject to all applicable copyright laws and is not for resale in any manner.

PUBLICATION ORDERING INFORMATION

LITERATURE FULFILLMENT:
Literature Distribution Center for ON Semiconductor
P.O. Box 5163, Denver, Colorado 80217 USA
Phone: 303-675-2175 or 800-344-3860 Toll Free USA/Canada
Fax: 303-675-2176 or 800-344-3867 Toll Free USA/Canada
Email: orderlit@onsemi.com

N. American Technical Support: 800-282-9855 Toll Free USA/Canada
Europe, Middle East and Africa Technical Support:
Phone: 421 33 790 2910
Japan Customer Focus Center
Phone: 81-3-5817-1050

ON Semiconductor Website: www.onsemi.com
Order Literature: <http://www.onsemi.com/orderlit>
For additional information, please contact your local Sales Representative



Стандарт Электрон Связь

Мы молодая и активно развивающаяся компания в области поставок электронных компонентов. Мы поставляем электронные компоненты отечественного и импортного производства напрямую от производителей и с крупнейших складов мира.

Благодаря сотрудничеству с мировыми поставщиками мы осуществляем комплексные и плановые поставки широчайшего спектра электронных компонентов.

Собственная эффективная логистика и склад в обеспечивает надежную поставку продукции в точно указанные сроки по всей России.

Мы осуществляем техническую поддержку нашим клиентам и предпродажную проверку качества продукции. На все поставляемые продукты мы предоставляем гарантию .

Осуществляем поставки продукции под контролем ВП МО РФ на предприятия военно-промышленного комплекса России , а также работаем в рамках 275 ФЗ с открытием отдельных счетов в уполномоченном банке. Система менеджмента качества компании соответствует требованиям ГОСТ ISO 9001.

Минимальные сроки поставки, гибкие цены, неограниченный ассортимент и индивидуальный подход к клиентам являются основой для выстраивания долгосрочного и эффективного сотрудничества с предприятиями радиоэлектронной промышленности, предприятиями ВПК и научно-исследовательскими институтами России.

С нами вы становитесь еще успешнее!

Наши контакты:

Телефон: +7 812 627 14 35

Электронная почта: sales@st-electron.ru

Адрес: 198099, Санкт-Петербург,
Промышленная ул, дом № 19, литера Н,
помещение 100-Н Офис 331