



ATmega4809 Curiosity Nano

ATmega4809 Curiosity Nano Hardware User Guide

Preface

The ATmega4809 Curiosity Nano evaluation kit is a hardware platform to evaluate the ATmega4809 microcontroller.

Supported by the Atmel Studio/Microchip MPLAB[®] X integrated development platform, the kit provides easy access to the features of the ATmega4809 and explains how to integrate the device into a custom design.

The Curiosity Nano series of evaluation kits include an onboard debugger, and no external tools are necessary to program the ATmega4809.

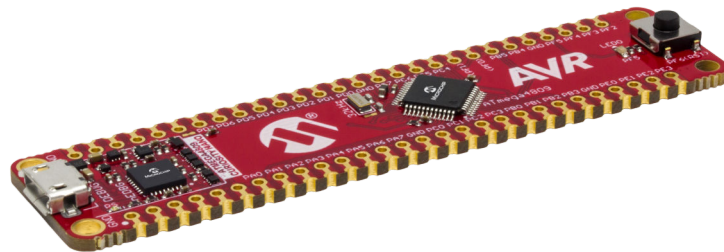

Table of Contents

Preface.....	1
1. Introduction.....	4
1.1. Features.....	4
1.2. Kit Overview.....	4
2. Getting Started.....	5
2.1. Curiosity Nano Quick Start.....	5
2.2. Design Documentation and Relevant Links.....	5
3. Curiosity Nano.....	6
3.1. Onboard Debugger.....	6
3.1.1. Virtual COM Port.....	6
3.1.2. Mass Storage Disk.....	8
3.2. Curiosity Nano Standard Pinout.....	9
3.3. Power Supply.....	10
3.3.1. Target Regulator.....	10
3.3.2. External Supply.....	11
3.4. Disconnecting the Onboard Debugger.....	11
3.5. Current Measurement.....	13
4. Hardware User Guide.....	14
4.1. Connectors.....	14
4.1.1. ATmega4809 Curiosity Nano Pinout.....	14
4.2. Peripherals.....	15
4.2.1. LED.....	15
4.2.2. Mechanical Switch.....	15
4.2.3. Crystal.....	15
4.3. Onboard Debugger Implementation.....	16
4.3.1. Onboard Debugger Connections.....	16
5. Hardware Revision History.....	17
5.1. Identifying Product ID and Revision.....	17
5.2. Revision 5.....	17
6. Document Revision History.....	18
7. Appendix.....	19
7.1. Schematic.....	19
7.2. Connecting External Debuggers.....	21
7.3. Getting Started with IAR.....	22
The Microchip Web Site.....	25
Customer Change Notification Service.....	25

Customer Support.....	25
Microchip Devices Code Protection Feature.....	25
Legal Notice.....	26
Trademarks.....	26
Quality Management System Certified by DNV.....	27
Worldwide Sales and Service.....	28

1. Introduction

1.1 Features

- ATmega4809-MFR microcontroller
- One yellow user LED
- One mechanical user switch
- One 32.768 kHz crystal
- Onboard debugger
 - Board identification in Atmel Studio/Microchip MPLAB® X
 - One green power and status LED
 - Programming and debugging
 - Virtual COM port (CDC)
 - Two logic analyzer channels (DGI GPIO)
- USB powered
- Adjustable target voltage
 - MIC5353 LDO regulator controlled by the onboard debugger
 - 1.8-5.1V output voltage (limited by USB input voltage)
 - 500 mA maximum output current (limited by ambient temperature and output voltage)

1.2 Kit Overview

The Microchip ATmega4809 Curiosity Nano evaluation kit is a hardware platform to evaluate the Microchip ATmega4809.

Figure 1-1. ATmega4809 Curiosity Nano Evaluation Kit Overview

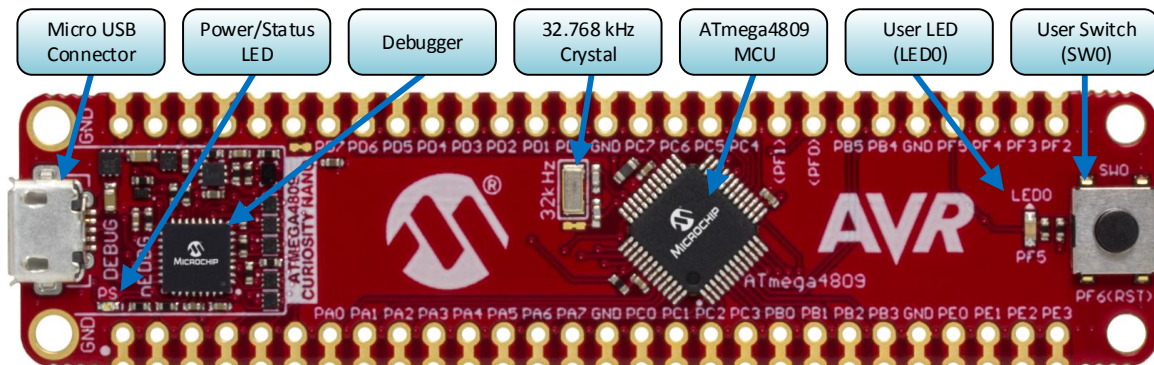

2. Getting Started

2.1 Curiosity Nano Quick Start

Steps to start exploring the Microchip Curiosity Nano platform:

1. Download Atmel Studio/Microchip MPLAB[®] X.
2. Launch Atmel Studio/Microchip MPLAB[®] X.
3. Connect a USB cable (Standard-A to Micro-B or Micro-AB) between the PC and the debug USB port on the kit.

When the Curiosity Nano kit is connected to your computer for the first time, the operating system will perform a driver software installation. The driver file supports both 32- and 64-bit versions of Microsoft[®] Windows[®] XP, Windows Vista[®], Windows 7, Windows 8, and Windows 10. The drivers for the kit are included with Atmel Studio/Microchip MPLAB[®] X.

Once the Curiosity Nano board is powered the green status LED will be lit and Atmel Studio/Microchip MPLAB[®] X will auto-detect which Curiosity Nano board is connected. Atmel Studio/Microchip MPLAB[®] X will present relevant information like data sheets and kit documentation. The ATmega4809 device is programmed by the onboard debugger and therefore no external programmer tool is required.

2.2 Design Documentation and Relevant Links

The following list contains links to the most relevant documents and software for the ATmega4809 Curiosity Nano.

- [MPLAB[®] X IDE](#) - MPLAB[®] X IDE is a software program that runs on a PC (Windows[®], Mac OS[®], Linux[®]) to develop applications for Microchip microcontrollers and digital signal controllers. It is called an Integrated Development Environment (IDE) because it provides a single integrated "environment" to develop code for embedded microcontrollers.
- [Atmel Studio](#) - Free IDE for the development of C/C++ and assembler code for microcontrollers.
- [IAR Embedded Workbench[®] for AVR[®]](#) - This is a commercial C/C++ compiler that is available for 8-bit AVR. There is a 30-day evaluation version as well as a 4 KB code-size-limited kick-start version available from their website.
- [Atmel START](#) - Atmel START is an online tool that helps the user to select and configure software components and tailor your embedded application in a usable and optimized manner.
- [Microchip Sample Store](#) - Microchip sample store where you can order samples of devices.
- [Data Visualizer](#) - Data Visualizer is a program used for processing and visualizing data. The Data Visualizer can receive data from various sources such as the EDBG Data Gateway Interface found on Curiosity Nano and Xplained Pro boards and COM Ports.
- [ATmega4809 Curiosity Nano website](#) - Kit information, latest user guide and design documentation.
- [ATmega4809 Curiosity Nano on Microchip Direct](#) - Purchase this kit on Microchip Direct.

3. Curiosity Nano

Curiosity Nano is an evaluation platform that provides a set of small boards with access to most of the microcontrollers I/Os. The platform consists of a series of low pin-count microcontroller (MCU) boards, which are integrated with Atmel Studio/Microchip MPLAB® X to present relevant user guides, application notes, data sheets, and example code. The platform features a Virtual COM port (CDC) for serial communication to a host PC and a Data Gateway Interface (DGI) GPIO.

3.1 Onboard Debugger

ATmega4809 Curiosity Nano contains an onboard debugger for programming and debugging. The onboard debugger is a composite USB device of several interfaces: a debugger, a mass storage device, a data gateway, and a Virtual COM port (CDC).

Together with Atmel Studio/Microchip MPLAB® X, the onboard debugger interface can program and debug the ATmega4809.

A Data Gateway Interface (DGI) is available for use with the logic analyzer channels for code instrumentation, to visualize program flow. DGI GPIOs can be graphed using the [Data Visualizer](#).

The Virtual COM port is connected to a UART on the ATmega4809 and provides an easy way to communicate with the target application through terminal software.

The onboard debugger controls one Power and Status LED (marked PS) on the ATmega4809 Curiosity Nano board. The table below shows how the LED is controlled in different operation modes.

Table 3-1. Onboard Debugger LED Control

Operation Mode	Status LED
Boot loader mode	LED blink at 1 Hz during power up.
Power-up	LED is lit - constant.
Normal operation	LED is lit - constant.
Programming	Activity indicator; the LED flashes slowly during programming/debugging.
Fault	The LED flashes fast if a power fault is detected.
Sleep/Off	LED is off. The onboard debugger is either in Sleep mode or powered down. This can occur if the kit is externally powered.

3.1.1 Virtual COM Port

A general purpose USB serial bridge between a host PC and a target device.

3.1.1.1 Overview

The debugger implements a composite USB device that includes a standard Communications Device Class (CDC) interface, which appears on the host as a Virtual COM Port. The CDC can be used to stream arbitrary data in both directions between the host and the target: characters sent from the host will appear in UART form on the CDC TX pin, and UART characters sent into the CDC RX pin will be sent back to the host.

On Windows machines, the CDC will enumerate as Curiosity Virtual COM Port and appear in the Ports section of the device manager. The COM port number is usually shown here.

Info: On older Windows systems a USB driver is required for CDC. This driver is included in Atmel Studio and MPLAB X installations.

On Linux machines, the CDC will enumerate and appear as `/dev/ttyACM#`.

On MAC machines, the CDC will enumerate and appear as `/dev/tty.usbmodem#`. Depending on which terminal program is used, it will appear in the available list of modems as `usbmodem#`.

3.1.1.2 Limitations

Not all UART features are implemented in the debugger CDC. The constraints are outlined here:

- **Baud rate** must be in the range 1200 bps to 500 kbps. Values outside this range will be capped to these values, without warning. Baud rate can be changed on-the-fly.
- **Character format:** only 8-bit characters are supported.
- **Parity:** can be odd, even, or none.
- **Hardware flow control:** not supported.
- **Stop bits:** one or two bits are supported.

3.1.1.3 Signaling

During USB **enumeration**, the host OS will start both communication and data pipes of the CDC interface. At this point, it is possible to set and read back baud rate and other UART parameters of the CDC, but data sending and receiving will not be enabled.

When a terminal connects on the host, it must assert the **DTR signal**. This is a virtual control signal that is implemented on the USB interface but not in hardware on the debugger. Asserting DTR from the host will indicate to the debugger that a CDC session is active, and it will enable its level shifters (if available), and start the CDC data send and receive mechanisms.

Deasserting the **DTR signal** will *not* disable the level shifters, but it will disable the receiver, so no further data will be streamed to the host. Data packets that are already queued up for sending to the target will continue to be sent out, but no further data will be accepted.

3.1.1.4 Advanced Use

CDC Override Mode

In normal operation, the onboard debugger is a true UART bridge between the host and the device. However, under certain use cases, the debugger can override the Basic Operating mode and use the CDC pins for other purposes.

Dropping a text file (with extension `.txt`) into the debugger's mass storage drive can be used to send characters out of the CDC TX pin. The text file must start with the characters:

```
CMD:SEND_UART=
```

The maximum message length is 50 characters - all remaining data in the frame is ignored.

The default baud rate used in this mode is 9600 bps, but if the CDC is already active or has been configured, the baud rate last used still applies.

USB-Level Framing Considerations

Sending data from the host to the CDC can be done byte-wise or in blocks, which will be chunked into 64-byte USB frames. Each such frame will be queued up for sending to the CDC TX pin. Sending a small amount of data per frame can be inefficient, particularly at low baud rates, since the debugger buffers

frames, not bytes. A maximum of 4 x 64-byte frames can be active at any time, the debugger will throttle the incoming frames accordingly. Sending full 64-byte frames containing data is the most efficient.

When **receiving data** from the target, the debugger will queue up incoming bytes into 64-byte frames, which are sent to the USB queue for transmission to the host when they are full. Incomplete frames are also pushed to the USB queue at approximately 100 ms intervals, triggered by USB start-of-frame tokens. Up to 8 x 64-byte frames can be active at any time. If the host, or software running on it, fails to receive data fast enough, an overrun will occur. When this happens the last-filled buffer frame will be recycled instead of being sent to the USB queue, and a full frame of data will be lost. To prevent this occurrence, the user must ensure that the CDC data pipe is being read continuously, or the incoming data rate must be reduced.

3.1.2 Mass Storage Disk

A simple way to program the target device through drag and drop with *.hex*-files.

3.1.2.1 Mass Storage Device

The debugger implements a highly optimized variant of the FAT12 file-system that has a number of limitations, partly due to the nature of FAT12 itself, and partly due to optimizations made to fulfill its purpose in this development kit.

The CURIOSITY drive *is* USB Chapter 9 compliant as a mass storage device but does not in any way fulfill the expectations of a general purpose mass storage device. This behavior is intentional.

The debugger enumerates as a Curiosity Nano USB device that can be found in the disk drives section of the Windows device manager. The CURIOSITY drive appears in the file manager and claims the next available drive letter in the system.

The CURIOSITY drive contains approximately 1 MB of free space. This does *not* reflect the size of the target device's flash in any way. When programming a hex file, the binary data is encoded in ASCII with metadata providing a large overhead, so 1 MB is a trivially chosen value for disk size.

It is *not* possible to format the CURIOSITY drive. When programming a file to the target, the filename may appear in the disk directory listing - this is merely the operating system's view of the directory, which, in reality, has not been updated. It is not possible to read out the file contents. Removing and replugging the kit will return the file system to its original state, but the target will still contain the application that has been previously programmed.

To erase the target device, simply copy a text file starting with "CMD:ERASE" onto the disk.

By default the CURIOSITY drive contains several read-only files for generating icons as well as reporting status and linking to further information:

- AUTORUN.ICO - Icon file for the Microchip logo.
- AUTORUN.INF - System file required for Windows Explorer to show the icon file.
- KIT-INFO.HTM - Redirect to the development board web site.
- KIT-INFO.TXT - A text file containing details about the kit firmware, name, serial number, and device.
- STATUS.TXT - A text file containing the programming status of the board.



Info: When STATUS.TXT is updated by the debugger dynamically, the contents may be cached by the OS and not reflect the correct status.

3.1.2.2 Configuration Words/Fuse Bytes

Fuse Bytes (AVR® Targets)

The debugger does *not* mask any fuse bits or combinations when writing fuses. It is not possible to disable UPDI by fuse setting on devices with a dedicated UPDI pin. For devices with a shared/configurable UPDI pin, be sure **not** to select an alternate pin function for UPDI either by fuse setting in Programming mode or by using the I/O view or memory views to modify the memory-mapped fuse values. Disabling UPDI will render the debugger unable to contact the target device — an external programmer capable of 12V UPDI activation will be required.

3.2 Curiosity Nano Standard Pinout

The twelve edge connections closest to the USB connector on Curiosity Nano kits have a standardized pinout. The program/debug pins have different functions depending on the target programming interface as shown in the table and figure below.

Table 3-2. Curiosity Nano Standard Pinout

Debugger Signal	UPDI Target	Description
ID	-	ID line for extensions.
CDC TX	UART RX	USB CDC TX line.
CDC RX	UART TX	USB CDC RX line.
DBG0	UPDI	Debug data line.
DBG1	GPIO1	Debug clock line/DGI GPIO
DBG2	GPIO0	DGI GPIO
DBG3	RESET	Reset line.
NC	-	No connect.
VBUS	-	VBUS voltage for external use.
VOFF	-	Voltage Off input.
VTG	-	Target voltage.
GND	-	Common ground.

Figure 3-1. Curiosity Nano Standard Pinout

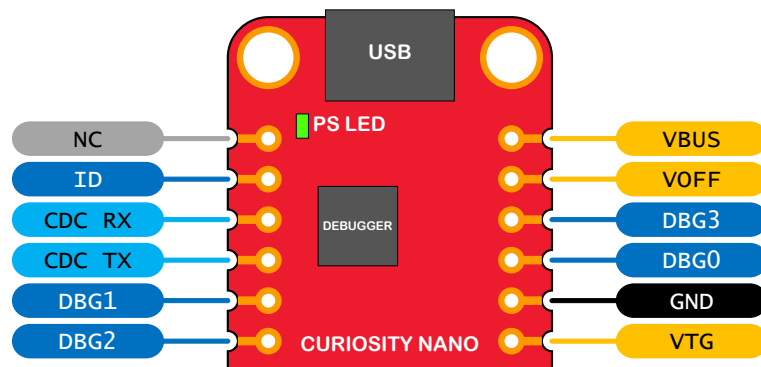

3.3 Power Supply

The kit is powered through the USB port and contains two regulators for generating 3.3V for the debugger and an adjustable regulator for the target. The voltage from the USB connector can vary between 4.4V to 5.25V (according to the USB specification) and will limit the maximum voltage to the target. The figure below shows the entire power supply system on ATmega4809 Curiosity Nano.

Figure 3-2. Power Supply Block Diagram

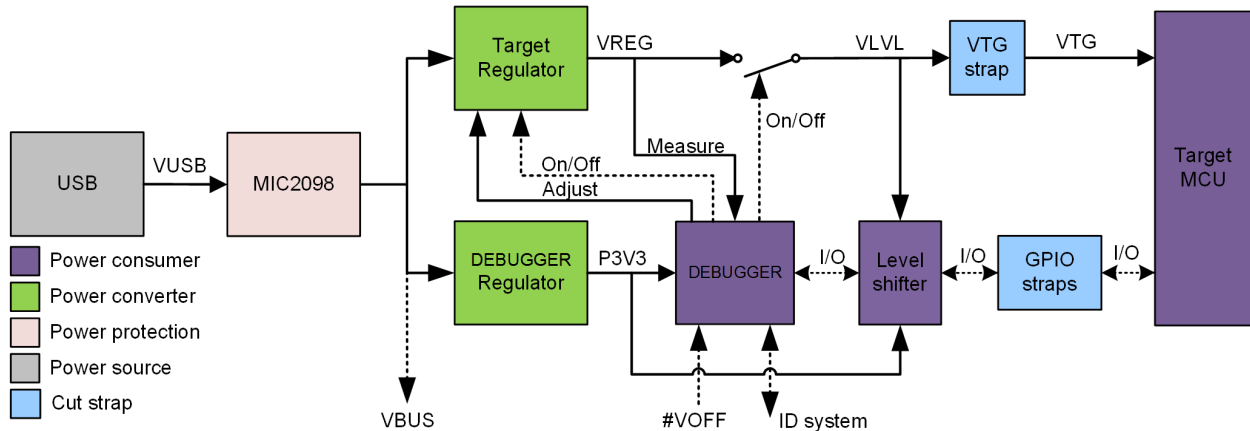

3.3.1 Target Regulator

The target voltage regulator is a MIC5353 variable output LDO. The onboard debugger can adjust the voltage output that is supplied to the kit target section by manipulating the MIC5353's feedback voltage. The hardware implementation is limited to an approximate voltage range from 1.7V to 5.1V. Additional output voltage limits are configured in the debugger firmware to ensure that the output voltage never exceeds the hardware limits of the ATmega4809 microcontroller. The voltage limits configured in the on-board debugger on ATmega4809 Curiosity Nano are 1.8-5.1V.

The target voltage is set to 3.3V in production and can be changed through Atmel Studio. Any change to the target voltage done in Atmel Studio is persistent, even through a power toggle.

The MIC5353 supports a maximum current load of 500 mA. It is an LDO regulator in a small package, placed on a small PCB, and the thermal shutdown condition can be reached at lower loads than 500 mA. The maximum current load depends on the input voltage, set output voltage, and the ambient temperature. The figure below shows the safe operation area for the regulator, with an input voltage of 5.1V and an ambient temperature of 23°C.

Figure 3-3. Target Regulator Safe Operation Area

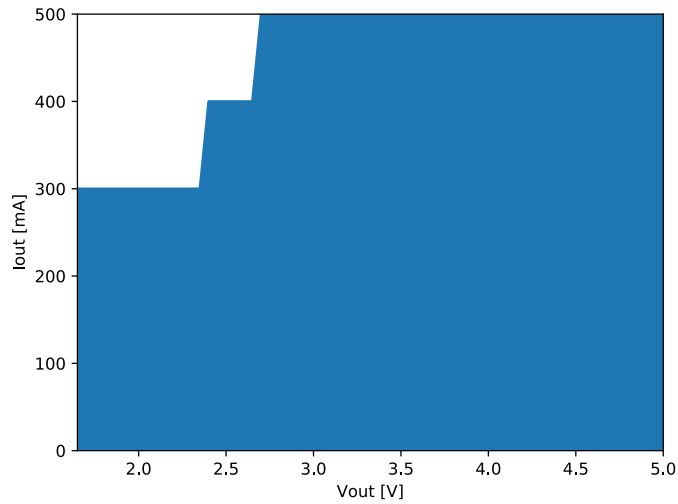

3.3.2 External Supply

ATmega4809 Curiosity Nano can be powered by an external voltage instead of the onboard target regulator. When the Voltage Off (*VOFF*) pin is shorted to ground (*GND*) the onboard debugger firmware disables the target regulator and it is safe to apply an external voltage to the VTG pin.



Applying an external voltage to the VTG pin without shorting *VOFF* to *GND* may cause permanent damage to the kit.



Absolute maximum external voltage is 5.5V for the level shifters onboard. Applying a higher voltage may cause permanent damage to the kit.

Programming, debugging, and data streaming is still possible while using external power: the debugger and signal level shifters will be powered from the USB cable. Both regulators, the debugger, and the level shifters are powered down when the USB cable is removed.

3.4 Disconnecting the Onboard Debugger

The block diagram below shows all connections between the debugger and the ATmega4809 microcontroller. The rounded boxes represent connections to the board edge on ATmega4809 Curiosity Nano. The signal names are shown in [Figure 3-1](#) and printed in silkscreen on the bottom side of the board.

Figure 3-4. Onboard Debugger Connections to the ATmega4809

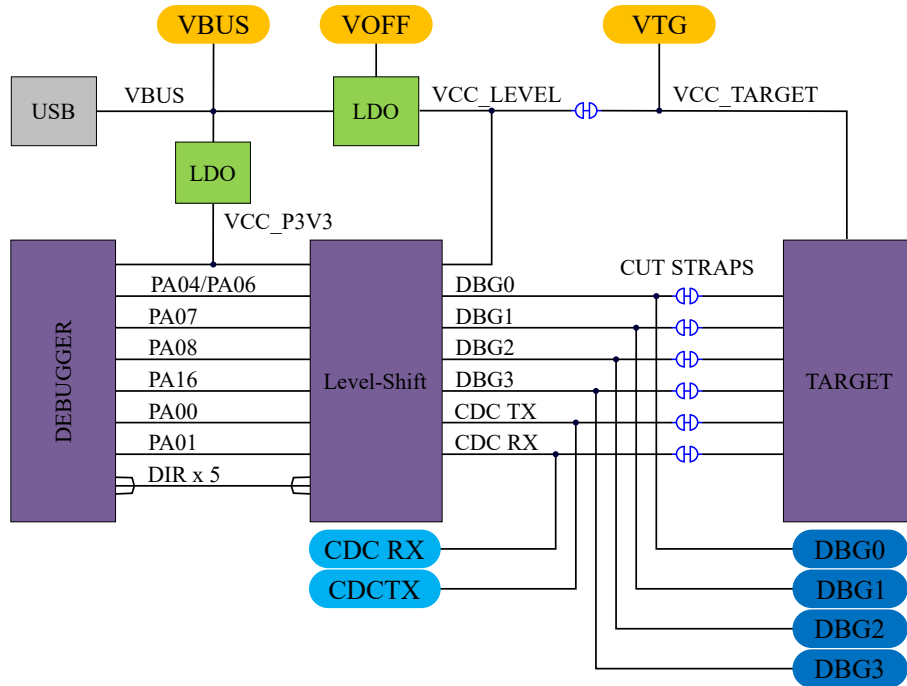

By cutting the *GPIO straps* with a sharp tool, as shown in [Figure 3-5](#), all I/Os connected between the debugger and the ATmega4809 are completely disconnected. To completely disconnect the target regulator, cut the VTG strap shown in [Figure 3-5](#).



Info: Cutting the connections to the debugger will disable programming, debugging, data streaming, and the target power supply. The signals will also be disconnected from the board edge next to the onboard debugger section.



Info: Solder in 0Ω resistors across the footprints or short-circuit them with tin solder to reconnect any cut signals.

Figure 3-5. Kit Modifications

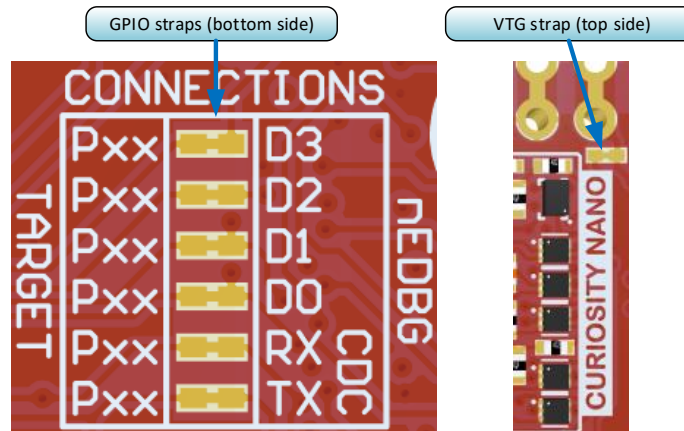

3.5 Current Measurement

The power to the ATmega4809 is connected from the onboard power supply to the target voltage supply (VTG) with a cut strap as shown in Section 3.4 [Disconnecting the Onboard Debugger](#). To measure the power consumption of the ATmega4809 and other peripherals connected to the board, cut the strap and connect an ammeter over the strap. The ammeter can be connected between the target VTG pad edge connector and an external power supply for easy measurement. Alternatively, an external power supply can be used as described in Section 3.3.2 [External Supply](#).



Info: The onboard level shifters will draw a small amount of current even when they are not in use. A maximum of 10 μA can be drawn from the VTG net and an additional 2 μA can be drawn from each I/O pin connected to a level shifter for a total of 20 μA . Disconnect the onboard debugger and level shifters as described in Section 3.4 [Disconnecting the Onboard Debugger](#) to prevent any leakage.

4. Hardware User Guide

4.1 Connectors

4.1.1 ATmega4809 Curiosity Nano Pinout

All the ATmega4809 I/O pins are accessible at the edge connectors on the board. The image below shows the kit pinout.

PF6 and the UPDI pin are only available at the edge connector in the debugger section as long as the cut-straps on the bottom side are not cut.

PF0 and PF1 are connected to the onboard crystal and not connected to the edge connector by default. See Section 4.2.3 [Crystal](#) for more information.

Figure 4-1. ATmega4809 Curiosity Nano Pinout

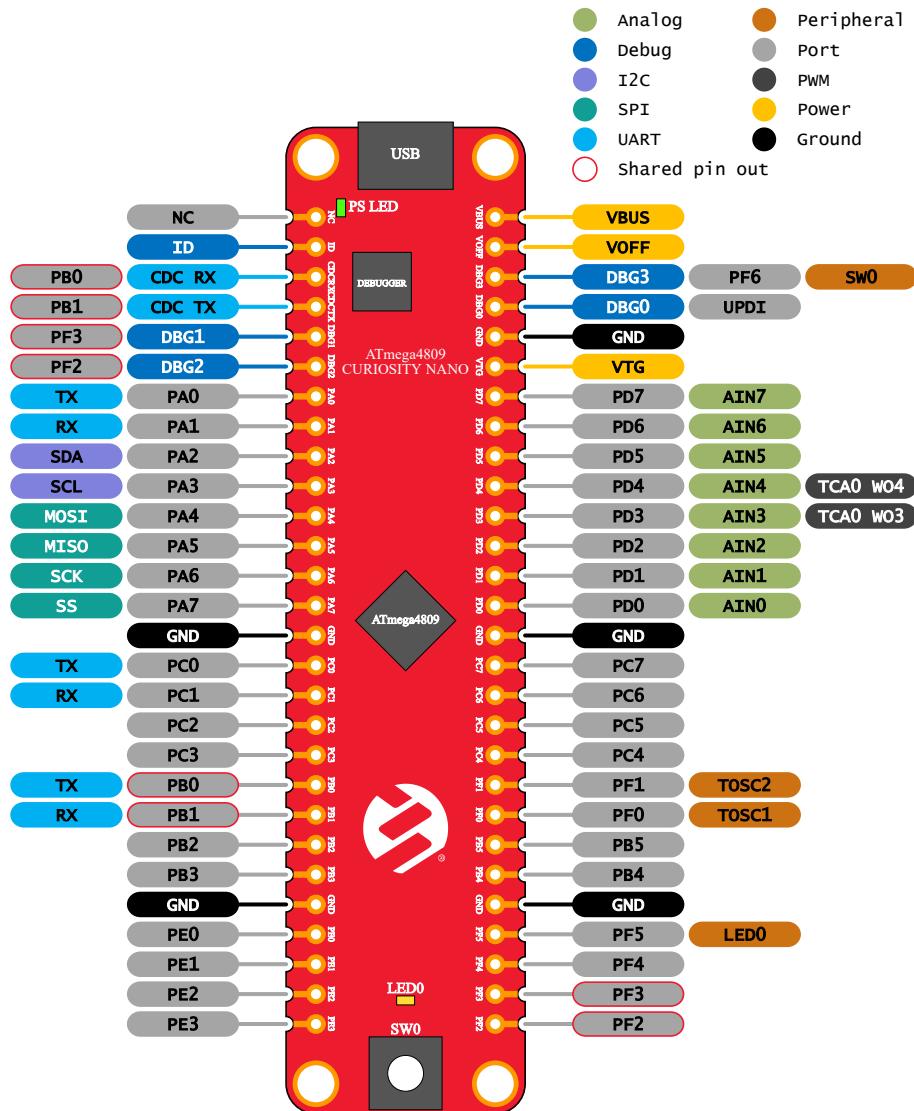

4.2 Peripherals

4.2.1 LED

There is one yellow user LED available on the ATmega4809 Curiosity Nano kit that can be controlled by either GPIO or PWM. The LED can be activated by driving the connected I/O line to GND.

Table 4-1. LED Connection

ATmega4809 Pin	Function	Shared Functionality
PF5	Yellow LED0	Edge connector

4.2.2 Mechanical Switch

ATmega4809 Curiosity Nano has one mechanical switch. This is a generic user configurable switch. When the switch is pressed, it will drive the I/O line to ground (GND).



Info: There is a 100 kΩ pull-up resistor connected to the generic user switch. An internal pull-up in the ATmega4809 is not required to use the switch.

Table 4-2. Mechanical Switch

ATmega4809 Pin	Description	Shared Functionality
PF6	User switch (SW0)	DBG3

4.2.3 Crystal

The ATmega4809 Curiosity Nano board has a 32.768 kHz crystal mounted.

The crystal is connected to the ATmega4809 by default, but the GPIOs are routed out to the edge connector through not mounted resistor footprints. The two I/O lines routed to the edge connector are disconnected by default to both reduce the chance of contention to the crystal as well as removing excessive capacitance on the lines when using the crystal. To use the pins PF0 and PF1 as GPIO on the edge connector, some hardware modification is needed. Solder a 0 Ω resistor or add a solder blob to the footprints to connect the routing. The crystal should be disconnected when using the pin as GPIO, as this might harm the crystal.

The 32.768 kHz crystal on ATmega4809 Curiosity Nano is a Kyocera Corporation ST3215SB32768C0HPWBB 7 pF crystal.

The crystal has been formally tested and matched to the ATmega4809 by Kyocera. The test report is available in the design documentation distributed with this document for ATmega4809 Curiosity Nano.



Info: Kyocera Crystal Device Corporation crystals that are matched with specific products can be found on their website: http://prdt-search.kyocera.co.jp/crystal-ic/?p=en_search/

Table 4-3. Crystal Connections

ATmega4809 Pin	Function	Shared Functionality
PF0	TOSC1 (Crystal input)	Edge connector
PF1	TOSC2 (Crystal output)	Edge connector

Figure 4-2. GPIO Connection Footprint



4.3 Onboard Debugger Implementation

ATmega4809 Curiosity Nano features an onboard debugger that can be used to program and debug the ATmega4809 using UPDI. The onboard debugger also includes a Virtual Com port interface over UART and DGI GPIO. Atmel Studio/Microchip MPLAB® X can be used as a front-end for the onboard debugger for programming and debugging. [Data Visualizer](#) can be used as a front-end for the CDC and DGI GPIO.

4.3.1 Onboard Debugger Connections

The table below shows the connections between the target and the debugger section. All connections between the target and the debugger are tri-stated as long as the debugger is not actively using the interface, hence there is little contamination of the signals, the pins can be configured to anything the user wants.

For further information on how to use the capabilities of the onboard debugger, see Section 3. [Curiosity Nano](#).

Table 4-4. Onboard Debugger Connections

ATmega4809 Pin	Debugger Pin	Function	Shared Functionality
PB1	CDC TX	UART RX (ATmega4809 RX line)	Edge connector
PB0	CDC RX	UART TX (ATmega4809 TX line)	Edge connector
UPDI	DBG0	UPDI	
PF3	DBG1	GPIO	Edge connector
PF2	DBG2	GPIO	Edge connector
PF6	DBG3	RESET/GPIO	User switch
VCC_TARGET	VCC_LEVEL	1.8-5.1V Supply	
GND	GND	Common ground	

5. Hardware Revision History

This user guide provides the latest available revision of the kit. This chapter contains information about known issues, a revision history of older revisions, and how older revisions differ from the latest revision.

5.1 Identifying Product ID and Revision

The revision and product identifier of Curiosity Nano boards can be found in two ways; either through Atmel Studio/Microchip MPLAB® X or by looking at the sticker on the bottom side of the PCB.

By connecting a Curiosity Nano board to a computer with Atmel Studio/Microchip MPLAB® X running, an information window will pop up. The first six digits of the serial number, which is listed under kit details, contain the product identifier and revision.

The same information can be found on the sticker on the bottom side of the PCB. Most kits will print the identifier and revision in plain text as A09-nnnn\rr, where nnnn is the identifier and rr is the revision. Boards with limited space have a sticker with only a QR-code, which contains a serial number string.

The serial number string has the following format:

```
"nnnnrrssssssss"
```

```
n = product identifier
```

```
r = revision
```

```
s = serial number
```

The product identifier for ATmega4809 Curiosity Nano is A09-3094.

5.2 Revision 5

Revision 5 is the initially released revision.

6. Document Revision History

Doc. rev.	Date	Comment
A	10/2018	Initial document release.

ATmega4809 Curiosity Nano

Appendix

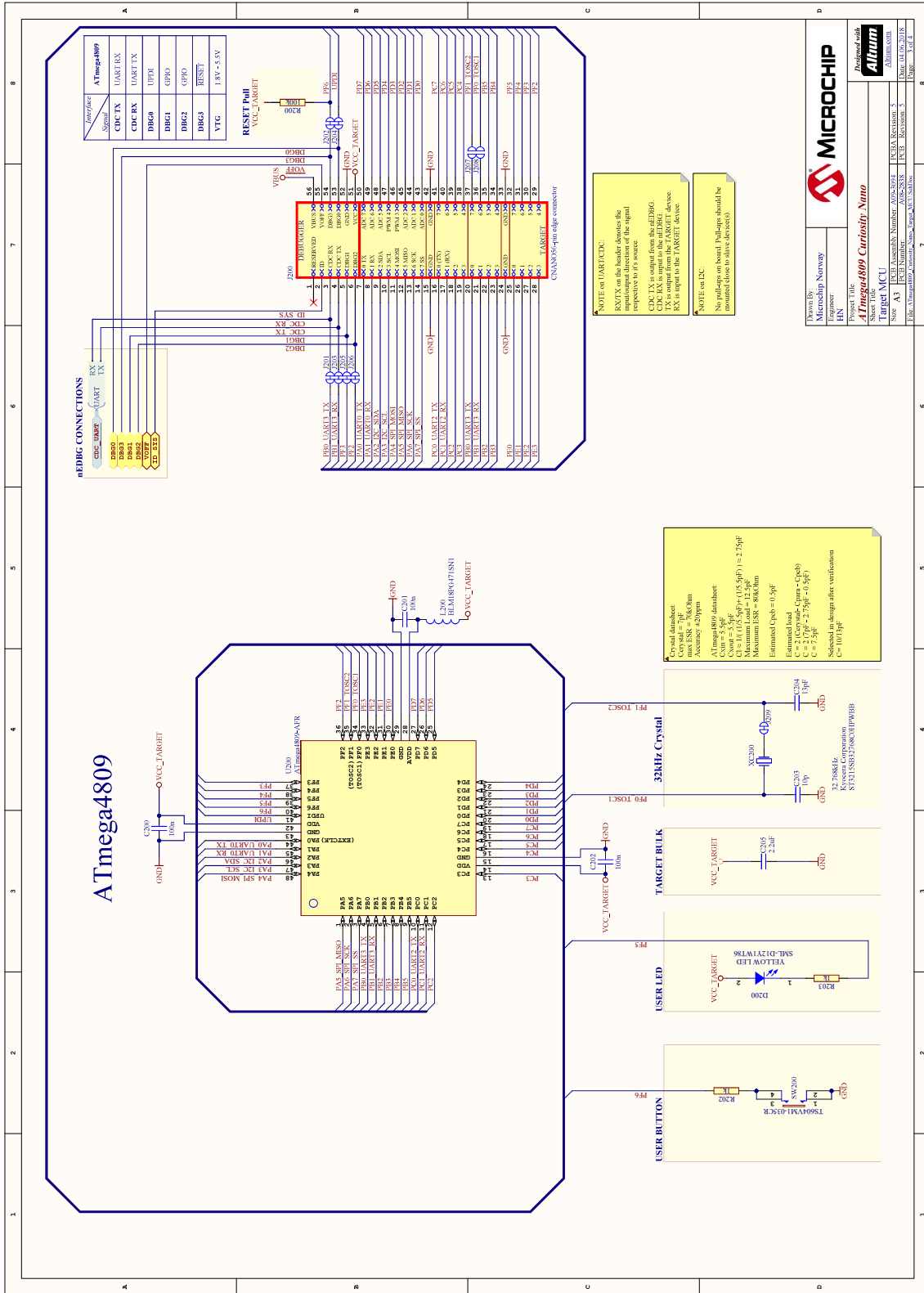

NOTE on UART/CDC:
 RX/TX on the header denotes the instantaneous direction of the signal respective to its source.
 RX is output from the ATmega4809. TX is output from the TARGET device. RX is input to the TARGET device.

NOTE on EIC:
 No pull-ups on board. Pullups should be provided externally to device (R200).

Crystal datasheet
 Crystal = 32.768 kHz
 Accuracy = ±20ppm
 ATmega4809 datasheet
 C_{load} = 5 pF
 C_{ext} = 12.5 pF (15.5 pF) = 2.7 nF
 Maximum Load = 12.5 pF
 Maximum ISR = 800 kHz
 Estimated C_{ext} = 0.3 pF
 Estimated load
 C = 2 (Crystal-C_{ext} + C_{load})
 C = 2 (5 pF + 12.5 pF) = 35 pF
 C = 2.7 nF
 C = 100 nF
 Selected in design after verification

Drawn By: **MICROCHIP**
 Checked By: **MICROCHIP**
 Project Title: **ATmega4809 Curiosity Nano**
 Target MCU: **ATmega4809**
 Size: **A3**
 PCB Number: **0000-2838**
 PCB Revision: **3**
 Date: **01/06/2018**
 File: **ATmega4809_Curiosity_Nano_PCB_Rev3_2x14**

7.2 Connecting External Debuggers

Even though there is an onboard debugger, external debuggers can be connected directly to ATmega4809 Curiosity Nano to program/debug the ATmega4809. The onboard debugger keeps all the pins connected to the ATmega4809 and board edge in tri-state when not actively used. Therefore, the onboard debugger will not interfere with any external debug tools.

Figure 7-2. Connecting the PICKit™ 4 to ATmega4809 Curiosity Nano

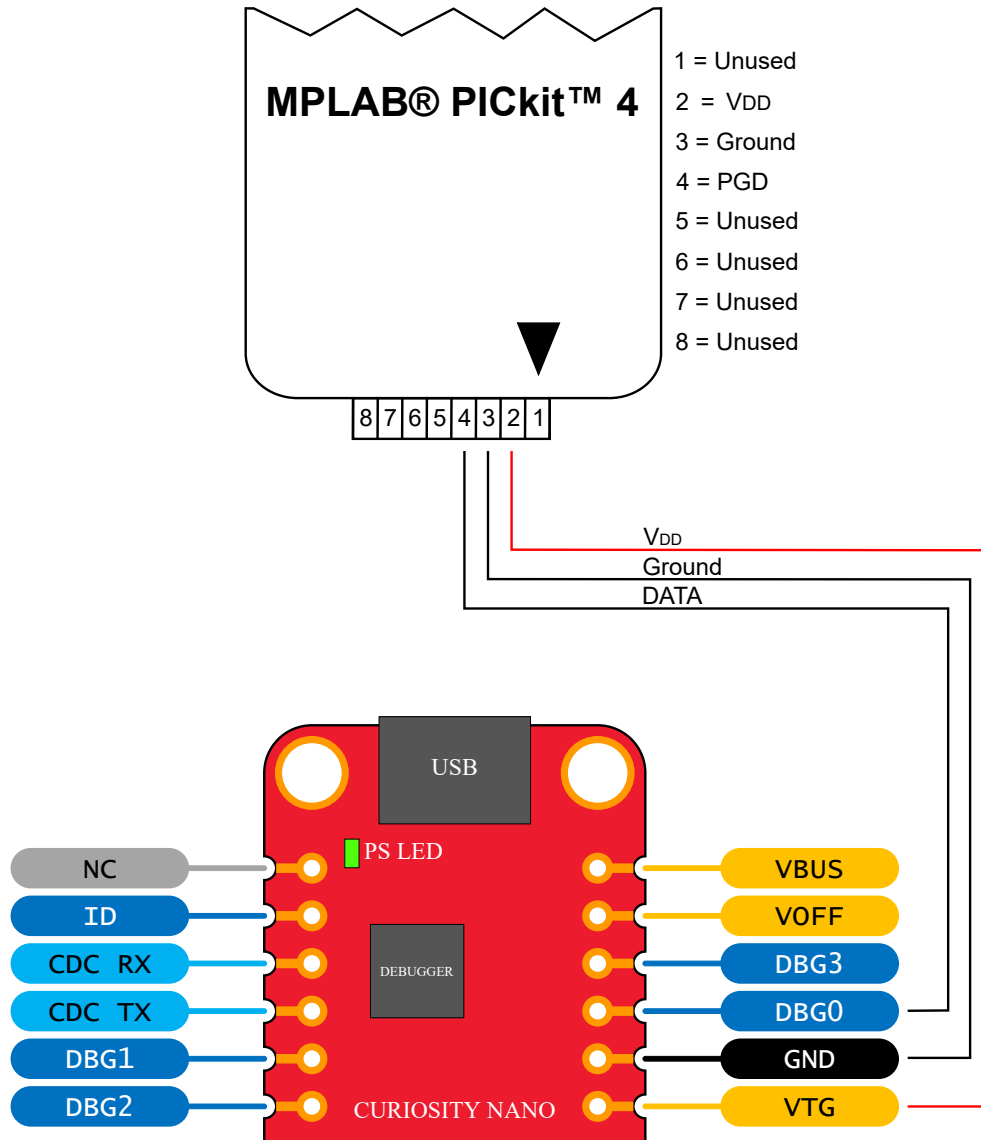
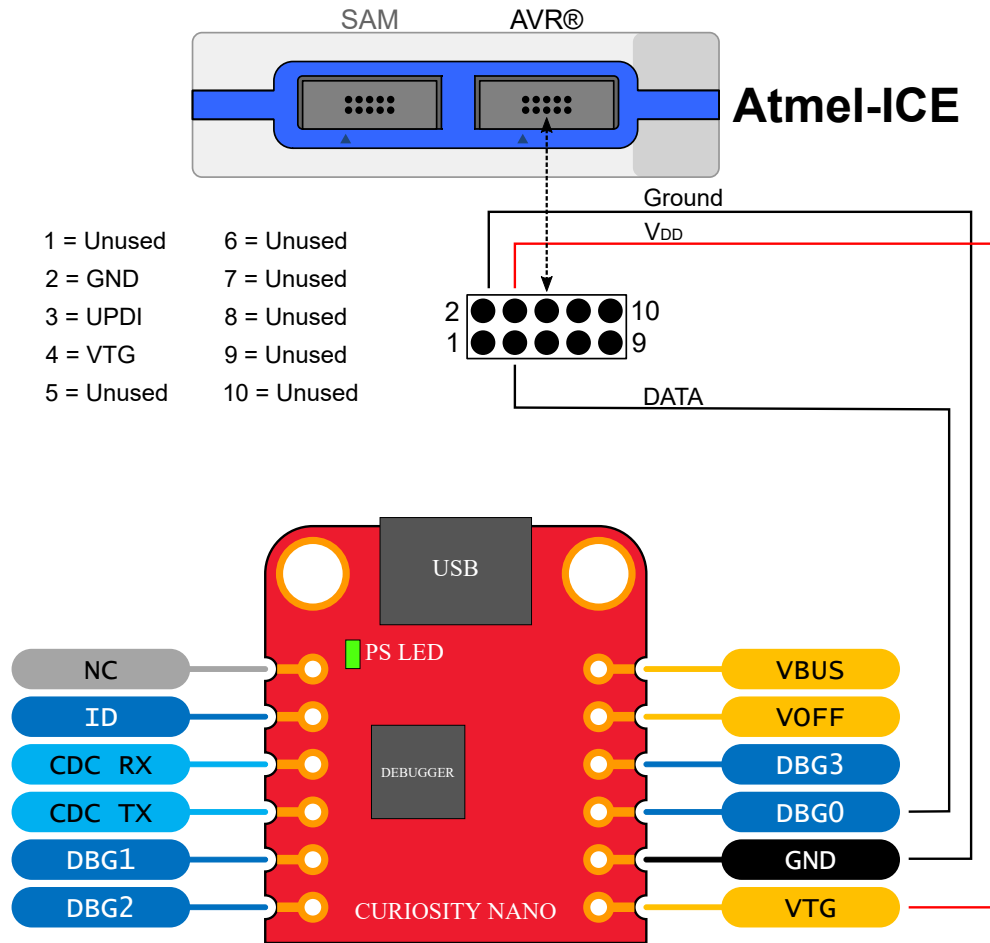

Figure 7-3. Connecting the Atmel-ICE to ATmega4809 Curiosity Nano



To avoid contention between the external debugger and the onboard debugger, do not start any programming/debug operation with the onboard debugger through Atmel Studio/Microchip MPLAB® X or mass storage programming while the external tool is active.

7.3 Getting Started with IAR

IAR Embedded Workbench® for AVR® is a proprietary high-efficiency compiler which is not based on GCC. Programming and debugging of ATmega4809 Curiosity Nano is supported in IAR™ Embedded Workbench for AVR using the Atmel-ICE interface. Some initial settings must be set up in the project to get the programming and debugging to work.

The following steps will explain how to get your project ready for programming and debugging:

1. Make sure you have opened the project you want to configure. Open the **OPTIONS** dialog for the project.
2. In the category **General Options**, select the **Target** tab. [Select the device for the project, or, if not listed, the core of the device.](#)
3. In the category **Debugger**, select the **Setup** tab. [Select Atmel-ICE as the driver.](#)

4. In the category **Debugger > Atmel-ICE**, select the **Atmel-ICE 1** tab. **Select UPDI as the interface and, optionally, select the UPDI frequency.**



Info: If the selection of Debug Port, mentioned in step 4, is grayed out, the interface is preselected, and the user can skip this configuration step.

Figure 7-4. Select Target Device

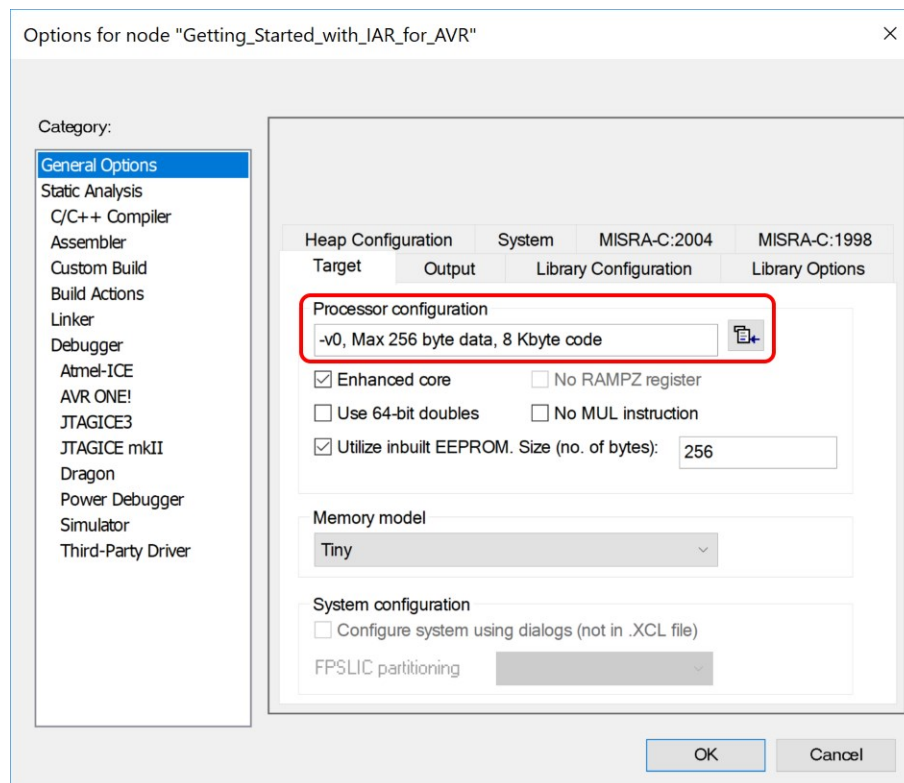

Figure 7-5. Select Debugger

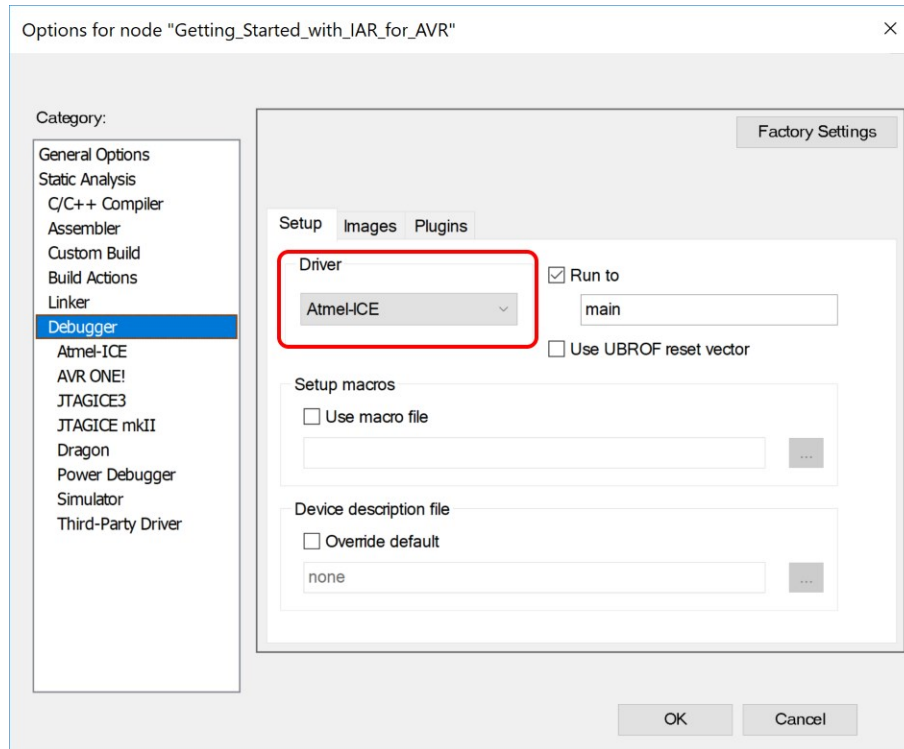
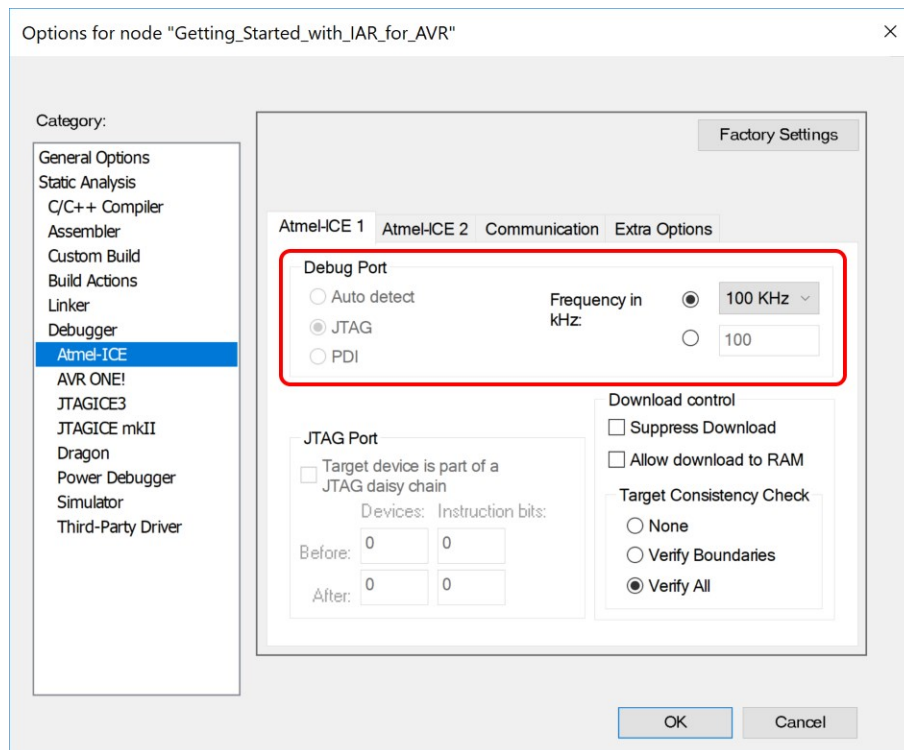

Figure 7-6. Configure Interface



The Microchip Web Site

Microchip provides online support via our web site at <http://www.microchip.com/>. This web site is used as a means to make files and information easily available to customers. Accessible by using your favorite Internet browser, the web site contains the following information:

- **Product Support** – Data sheets and errata, application notes and sample programs, design resources, user's guides and hardware support documents, latest software releases and archived software
- **General Technical Support** – Frequently Asked Questions (FAQ), technical support requests, online discussion groups, Microchip consultant program member listing
- **Business of Microchip** – Product selector and ordering guides, latest Microchip press releases, listing of seminars and events, listings of Microchip sales offices, distributors and factory representatives

Customer Change Notification Service

Microchip's customer notification service helps keep customers current on Microchip products. Subscribers will receive e-mail notification whenever there are changes, updates, revisions or errata related to a specified product family or development tool of interest.

To register, access the Microchip web site at <http://www.microchip.com/>. Under "Support", click on "Customer Change Notification" and follow the registration instructions.

Customer Support

Users of Microchip products can receive assistance through several channels:

- Distributor or Representative
- Local Sales Office
- Field Application Engineer (FAE)
- Technical Support

Customers should contact their distributor, representative or Field Application Engineer (FAE) for support. Local sales offices are also available to help customers. A listing of sales offices and locations is included in the back of this document.

Technical support is available through the web site at: <http://www.microchip.com/support>

Microchip Devices Code Protection Feature

Note the following details of the code protection feature on Microchip devices:

- Microchip products meet the specification contained in their particular Microchip Data Sheet.
- Microchip believes that its family of products is one of the most secure families of its kind on the market today, when used in the intended manner and under normal conditions.
- There are dishonest and possibly illegal methods used to breach the code protection feature. All of these methods, to our knowledge, require using the Microchip products in a manner outside the operating specifications contained in Microchip's Data Sheets. Most likely, the person doing so is engaged in theft of intellectual property.
- Microchip is willing to work with the customer who is concerned about the integrity of their code.

- Neither Microchip nor any other semiconductor manufacturer can guarantee the security of their code. Code protection does not mean that we are guaranteeing the product as “unbreakable.”

Code protection is constantly evolving. We at Microchip are committed to continuously improving the code protection features of our products. Attempts to break Microchip’s code protection feature may be a violation of the Digital Millennium Copyright Act. If such acts allow unauthorized access to your software or other copyrighted work, you may have a right to sue for relief under that Act.

Legal Notice

Information contained in this publication regarding device applications and the like is provided only for your convenience and may be superseded by updates. It is your responsibility to ensure that your application meets with your specifications. MICROCHIP MAKES NO REPRESENTATIONS OR WARRANTIES OF ANY KIND WHETHER EXPRESS OR IMPLIED, WRITTEN OR ORAL, STATUTORY OR OTHERWISE, RELATED TO THE INFORMATION, INCLUDING BUT NOT LIMITED TO ITS CONDITION, QUALITY, PERFORMANCE, MERCHANTABILITY OR FITNESS FOR PURPOSE. Microchip disclaims all liability arising from this information and its use. Use of Microchip devices in life support and/or safety applications is entirely at the buyer’s risk, and the buyer agrees to defend, indemnify and hold harmless Microchip from any and all damages, claims, suits, or expenses resulting from such use. No licenses are conveyed, implicitly or otherwise, under any Microchip intellectual property rights unless otherwise stated.

Trademarks

The Microchip name and logo, the Microchip logo, AnyRate, AVR, AVR logo, AVR Freaks, BitCloud, chipKIT, chipKIT logo, CryptoMemory, CryptoRF, dsPIC, FlashFlex, flexPWR, Heldo, JukeBlox, KeeLoq, Klear, LANCheck, LINK MD, maXStylus, maXTouch, MediaLB, megaAVR, MOST, MOST logo, MPLAB, OptoLyzer, PIC, picoPower, PICSTART, PIC32 logo, Prochip Designer, QTouch, SAM-BA, SpyNIC, SST, SST Logo, SuperFlash, tinyAVR, UNI/O, and XMEGA are registered trademarks of Microchip Technology Incorporated in the U.S.A. and other countries.

ClockWorks, The Embedded Control Solutions Company, EtherSynch, Hyper Speed Control, HyperLight Load, IntelliMOS, mTouch, Precision Edge, and Quiet-Wire are registered trademarks of Microchip Technology Incorporated in the U.S.A.

Adjacent Key Suppression, AKS, Analog-for-the-Digital Age, Any Capacitor, AnyIn, AnyOut, BodyCom, CodeGuard, CryptoAuthentication, CryptoAutomotive, CryptoCompanion, CryptoController, dsPICDEM, dsPICDEM.net, Dynamic Average Matching, DAM, ECAN, EtherGREEN, In-Circuit Serial Programming, ICSP, INICnet, Inter-Chip Connectivity, JitterBlocker, KlearNet, KlearNet logo, memBrain, Mindi, MiWi, motorBench, MPASM, MPF, MPLAB Certified logo, MPLIB, MPLINK, MultiTRAK, NetDetach, Omniscient Code Generation, PICDEM, PICDEM.net, PICKit, PICtail, PowerSmart, PureSilicon, QMatrix, REAL ICE, Ripple Blocker, SAM-ICE, Serial Quad I/O, SMART-I.S., SQI, SuperSwitcher, SuperSwitcher II, Total Endurance, TSHARC, USBCheck, VariSense, ViewSpan, WiperLock, Wireless DNA, and ZENA are trademarks of Microchip Technology Incorporated in the U.S.A. and other countries.

SQTP is a service mark of Microchip Technology Incorporated in the U.S.A.

Silicon Storage Technology is a registered trademark of Microchip Technology Inc. in other countries.

GestIC is a registered trademark of Microchip Technology Germany II GmbH & Co. KG, a subsidiary of Microchip Technology Inc., in other countries.

All other trademarks mentioned herein are property of their respective companies.

© 2018, Microchip Technology Incorporated, Printed in the U.S.A., All Rights Reserved.

ISBN: 978-1-5224-3628-7

Quality Management System Certified by DNV

ISO/TS 16949

Microchip received ISO/TS-16949:2009 certification for its worldwide headquarters, design and wafer fabrication facilities in Chandler and Tempe, Arizona; Gresham, Oregon and design centers in California and India. The Company's quality system processes and procedures are for its PIC[®] MCUs and dsPIC[®] DSCs, KEELOQ[®] code hopping devices, Serial EEPROMs, microperipherals, nonvolatile memory and analog products. In addition, Microchip's quality system for the design and manufacture of development systems is ISO 9001:2000 certified.

Worldwide Sales and Service

AMERICAS	ASIA/PACIFIC	ASIA/PACIFIC	EUROPE
<p>Corporate Office 2355 West Chandler Blvd. Chandler, AZ 85224-6199 Tel: 480-792-7200 Fax: 480-792-7277 Technical Support: http://www.microchip.com/support Web Address: www.microchip.com</p> <p>Atlanta Duluth, GA Tel: 678-957-9614 Fax: 678-957-1455</p> <p>Austin, TX Tel: 512-257-3370</p> <p>Boston Westborough, MA Tel: 774-760-0087 Fax: 774-760-0088</p> <p>Chicago Itasca, IL Tel: 630-285-0071 Fax: 630-285-0075</p> <p>Dallas Addison, TX Tel: 972-818-7423 Fax: 972-818-2924</p> <p>Detroit Novi, MI Tel: 248-848-4000</p> <p>Houston, TX Tel: 281-894-5983</p> <p>Indianapolis Noblesville, IN Tel: 317-773-8323 Fax: 317-773-5453 Tel: 317-536-2380</p> <p>Los Angeles Mission Viejo, CA Tel: 949-462-9523 Fax: 949-462-9608 Tel: 951-273-7800</p> <p>Raleigh, NC Tel: 919-844-7510</p> <p>New York, NY Tel: 631-435-6000</p> <p>San Jose, CA Tel: 408-735-9110 Tel: 408-436-4270</p> <p>Canada - Toronto Tel: 905-695-1980 Fax: 905-695-2078</p>	<p>Australia - Sydney Tel: 61-2-9868-6733</p> <p>China - Beijing Tel: 86-10-8569-7000</p> <p>China - Chengdu Tel: 86-28-8665-5511</p> <p>China - Chongqing Tel: 86-23-8980-9588</p> <p>China - Dongguan Tel: 86-769-8702-9880</p> <p>China - Guangzhou Tel: 86-20-8755-8029</p> <p>China - Hangzhou Tel: 86-571-8792-8115</p> <p>China - Hong Kong SAR Tel: 852-2943-5100</p> <p>China - Nanjing Tel: 86-25-8473-2460</p> <p>China - Qingdao Tel: 86-532-8502-7355</p> <p>China - Shanghai Tel: 86-21-3326-8000</p> <p>China - Shenyang Tel: 86-24-2334-2829</p> <p>China - Shenzhen Tel: 86-755-8864-2200</p> <p>China - Suzhou Tel: 86-186-6233-1526</p> <p>China - Wuhan Tel: 86-27-5980-5300</p> <p>China - Xian Tel: 86-29-8833-7252</p> <p>China - Xiamen Tel: 86-592-2388138</p> <p>China - Zhuhai Tel: 86-756-3210040</p>	<p>India - Bangalore Tel: 91-80-3090-4444</p> <p>India - New Delhi Tel: 91-11-4160-8631</p> <p>India - Pune Tel: 91-20-4121-0141</p> <p>Japan - Osaka Tel: 81-6-6152-7160</p> <p>Japan - Tokyo Tel: 81-3-6880-3770</p> <p>Korea - Daegu Tel: 82-53-744-4301</p> <p>Korea - Seoul Tel: 82-2-554-7200</p> <p>Malaysia - Kuala Lumpur Tel: 60-3-7651-7906</p> <p>Malaysia - Penang Tel: 60-4-227-8870</p> <p>Philippines - Manila Tel: 63-2-634-9065</p> <p>Singapore Tel: 65-6334-8870</p> <p>Taiwan - Hsin Chu Tel: 886-3-577-8366</p> <p>Taiwan - Kaohsiung Tel: 886-7-213-7830</p> <p>Taiwan - Taipei Tel: 886-2-2508-8600</p> <p>Thailand - Bangkok Tel: 66-2-694-1351</p> <p>Vietnam - Ho Chi Minh Tel: 84-28-5448-2100</p>	<p>Austria - Wels Tel: 43-7242-2244-39 Fax: 43-7242-2244-393</p> <p>Denmark - Copenhagen Tel: 45-4450-2828 Fax: 45-4485-2829</p> <p>Finland - Espoo Tel: 358-9-4520-820</p> <p>France - Paris Tel: 33-1-69-53-63-20 Fax: 33-1-69-30-90-79</p> <p>Germany - Garching Tel: 49-8931-9700</p> <p>Germany - Haan Tel: 49-2129-3766400</p> <p>Germany - Heilbronn Tel: 49-7131-67-3636</p> <p>Germany - Karlsruhe Tel: 49-721-625370</p> <p>Germany - Munich Tel: 49-89-627-144-0 Fax: 49-89-627-144-44</p> <p>Germany - Rosenheim Tel: 49-8031-354-560</p> <p>Israel - Ra'anana Tel: 972-9-744-7705</p> <p>Italy - Milan Tel: 39-0331-742611 Fax: 39-0331-466781</p> <p>Italy - Padova Tel: 39-049-7625286</p> <p>Netherlands - Drunen Tel: 31-416-690399 Fax: 31-416-690340</p> <p>Norway - Trondheim Tel: 47-72884388</p> <p>Poland - Warsaw Tel: 48-22-3325737</p> <p>Romania - Bucharest Tel: 40-21-407-87-50</p> <p>Spain - Madrid Tel: 34-91-708-08-90 Fax: 34-91-708-08-91</p> <p>Sweden - Gothenberg Tel: 46-31-704-60-40</p> <p>Sweden - Stockholm Tel: 46-8-5090-4654</p> <p>UK - Wokingham Tel: 44-118-921-5800 Fax: 44-118-921-5820</p>

Mouser Electronics

Authorized Distributor

Click to View Pricing, Inventory, Delivery & Lifecycle Information:

[Microchip:](#)

[DM320115](#)



Стандарт Электрон Связь

Мы молодая и активно развивающаяся компания в области поставок электронных компонентов. Мы поставляем электронные компоненты отечественного и импортного производства напрямую от производителей и с крупнейших складов мира.

Благодаря сотрудничеству с мировыми поставщиками мы осуществляем комплексные и плановые поставки широчайшего спектра электронных компонентов.

Собственная эффективная логистика и склад в обеспечивает надежную поставку продукции в точно указанные сроки по всей России.

Мы осуществляем техническую поддержку нашим клиентам и предпродажную проверку качества продукции. На все поставляемые продукты мы предоставляем гарантию .

Осуществляем поставки продукции под контролем ВП МО РФ на предприятия военно-промышленного комплекса России , а также работаем в рамках 275 ФЗ с открытием отдельных счетов в уполномоченном банке. Система менеджмента качества компании соответствует требованиям ГОСТ ISO 9001.

Минимальные сроки поставки, гибкие цены, неограниченный ассортимент и индивидуальный подход к клиентам являются основой для выстраивания долгосрочного и эффективного сотрудничества с предприятиями радиоэлектронной промышленности, предприятиями ВПК и научно-исследовательскими институтами России.

С нами вы становитесь еще успешнее!

Наши контакты:

Телефон: +7 812 627 14 35

Электронная почта: sales@st-electron.ru

Адрес: 198099, Санкт-Петербург,
Промышленная ул, дом № 19, литера Н,
помещение 100-Н Офис 331