

Inolux Surface Mount High Power Ultraviolet LED IN-3531ACUV

Official Product	Product: IN-3531ACUV			Data Sheet No.
Tentative Product	*****			IN-3531ACUV
Specifications are subject to change without notice. Data and drawings herein are copyrighted.		Jan. 17, 2013	Version of 1.0	Page 1/13

DISCLAIMER.....	3
LABEL SPECIFICATIONS.....	4
RADIOMETRIC POWER AND FORWARD VOLTAGE.....	4
FORWARD VOLTAGE BINNING.....	5
PRODUCT CHARACTERISTICS.....	6
ABSOLUTE MAXIMUM RATINGS.....	6
ELECTRO-OPTICAL CHARACTERISTICS.....	6
PACKAGE OUTLINE DIMENSION.....	7
RECOMMENDED SOLDERING PATTERN FOR REFLOW SOLDERING.....	7
CHARACTERISTIC CURVES.....	8
THERMAL DESIGN.....	9
PACKING INFORMATION.....	12
REVISION HISTORY.....	13

Official Product	Product: IN-3531ACUV		Data Sheet No.
Tentative Product	*****		IN-3531ACUV
Specifications are subject to change without notice. Data and drawings herein are copyrighted.	Jan. 17, 2013	Version of 1.0	Page 2/13

DISCLAIMER

INOLUX reserves the right to make changes without further notice to any products herein to improve reliability, function or design. INOLUX does not assume any liability arising out of the application or use of any product or circuit described herein; neither does it convey any license under its patent rights, nor the rights of others.

LIFE SUPPORT POLICY

INOLUX's products are not authorized for use as critical components in life support devices or systems without the express written approval of the President of INOLUX or INOLUX Technologies. As used herein:

1. Life support devices or systems are devices or systems which, (a) are intended for surgical implant into the body, or (b) support or sustain life, and (c) whose failure to perform when properly used in accordance with instructions for use provided in the labeling, can be reasonably expected to result in a significant injury of the user.

2. A critical component in any component of a life support device or system whose failure to perform can be reasonably expected to cause the failure of the life support device or system, or to affect its safety or effectiveness.

Official Product	Product: IN-3531ACUV			Data Sheet No.
Tentative Product	*****			IN-3531ACUV
Specifications are subject to change without notice. Data and drawings herein are copyrighted.	Jan. 17, 2013	Version of 1.0	Page 3/13	

Label Specifications

INOLUX P/N:

I N - 3 5 3 1 A C U V - X X X X

Series Name	Substrate / Emitting Color	Customer Code
IN-3531 Inolux 3531 package	Aluminum Nitride substrate UV@380-420nm	XXXX Customer Product Code

Lot No.:

1	2	3	4	5	6	7	8	9	10
E	1	A	1	A	2	2	L	1	2
Code 1 2		Code 3	Code 4	Code 5	Code 6	Code 7	Code 8	Code 9	Code 10
		Mfg. Year	Mfg. Month	Mfg. Date	Consecutive number		Special code		
Internal Tracing Code		2010-A 2011-B 2012-C 2013-D . .	1:Jan. 2:Feb. ... A:Oct. B:Nov. C:Dec.	1:A 2:B 3:C ... 26:Z 27:7 28:8 29:9 30:3 31:4	01~ZZ		000~ZZZ		

Radiometric Power and Forward Voltage

(T_j =25 °C)

Part Number	Color	Performance at Test Current 350mA			Performance at 700mA
		Group	Min.	V _f	Typical

Official Product	Product: IN-3531ACUV	Data Sheet No.
Tentative Product	*****	IN-3531ACUV
Specifications are subject to change without notice. Data and drawings herein are copyrighted.	Jan. 17, 2013	Version of 1.0
		Page 4/13

			Radiometric Power (mW)	Min	Max	Radiometric Power (mW)
IN-3531ACUV	U40 (380~390nm)	D1	200	3	4	340
		D2	240	3	4	410
		D3	280	3	4	475
	U50 (390~400nm)	D4	320	3	4	545
		D5	360	3	4	610
		E1	400	3	4	680
		E2	440	3	4	750
	U60 (400~410nm)	D4	320	3	4	545
		D5	360	3	4	610
		E1	400	3	4	680
		E2	440	3	4	750
		E3	480	3	4	815
	U70 (410~420nm)	D4	320	3	4	545
		D5	360	3	4	610
		E1	400	3	4	680
		E2	440	3	4	750
		E3	480	3	4	815
		E4	520	3	4	885

Note:

1. Radiometric Power is measured with an accuracy of $\pm 10\%$
2. The forward voltage is measured with an accuracy of $\pm 0.2V$

* Calculated values are for reference only.

Forward Voltage Binning

Part Number	Performance at Test Current (350mA)		
	V _f Group	Minimum (V)	Maximum (V)
IN-3531ACUV	V30	3.0	3.2
	V32	3.2	3.4
	V34	3.4	3.6
	V36	3.6	3.8

Official Product	Product: IN-3531ACUV	Data Sheet No.
Tentative Product	*****	IN-3531ACUV
Specifications are subject to change without notice. Data and drawings herein are copyrighted.	Jan. 17, 2013	Version of 1.0
		Page 5/13

	V38	3.8	4.0
--	-----	-----	-----

Product Characteristics

Absolute Maximum Ratings

(T_j = 25 °C)

Parameter	Rating
DC Forward Current (mA)	800mA
LED Junction Temperature	150°C
LED Operating Temperature	-40°C ~ 125°C
Storage Temperature	-40°C ~ 125°C
Soldering Temperature	Max. 260°C / Max. 10 sec. (JEDEC 020c)
ESD Sensitivity	2,000V HBM (JESD-22A-114-B)
Preconditioning	Acc. to JEDEC Level 2

Notes:

1. Never operate the LEDs in reverse bias.
2. Do not drive at rated current for more than 5 seconds without proper thermal management.
3. When the LEDs are illuminating, operating current should be decided after considering the packages maximum temperature.
4. Caution: These devices emit high intensity UV/NUV light. Necessary precautions must be taken during operation. Do not look directly into the light or look through the optical system when in operation. Protective eyewear should be worn at all times during operation.
5. Lens discoloration may occur with prolonged exposure to UV/NUV light. Lens material will need to be tested for UV/NUV light compatibility and durability.

Electro-Optical Characteristics

(T_j 25 °C)

Part Number	Color	Peak Wavelength (λ _p)		2Θ1/2	Temperature Coefficient of V _f (mV/°C)	Thermal Resistance Junction to Pad
		Min	Max		ΔV _f / ΔT _J	(°C/W) R _{ΘJ-L}

Official Product	Product: IN-3531ACUV	Data Sheet No.
Tentative Product	*****	IN-3531ACUV
Specifications are subject to change without notice. Data and drawings herein are copyrighted.	Jan. 17, 2013	Version of 1.0
		Page 6/13

IN-3531ACUV	U40	380	390	125	-2~-4	4.4
	U50	390	400	125	-2~-4	4.4
	U60	400	410	125	-2~-4	4.4
	U70	410	420	125	-2~-4	4.4

Notes:

1. The peak/dominant wavelength is measured with an accuracy of $\pm 1\text{nm}$.

Package Outline Dimension Recommended Soldering Pattern for Reflow Soldering

Unit: mm Tolerance: +/-0.13

Outline Dimension	Solder Pattern
-------------------	----------------

Official Product	Product: IN-3531ACUV		Data Sheet No.
Tentative Product	*****		IN-3531ACUV
Specifications are subject to change without notice. Data and drawings herein are copyrighted.	Jan. 17, 2013	Version of 1.0	Page 7/13

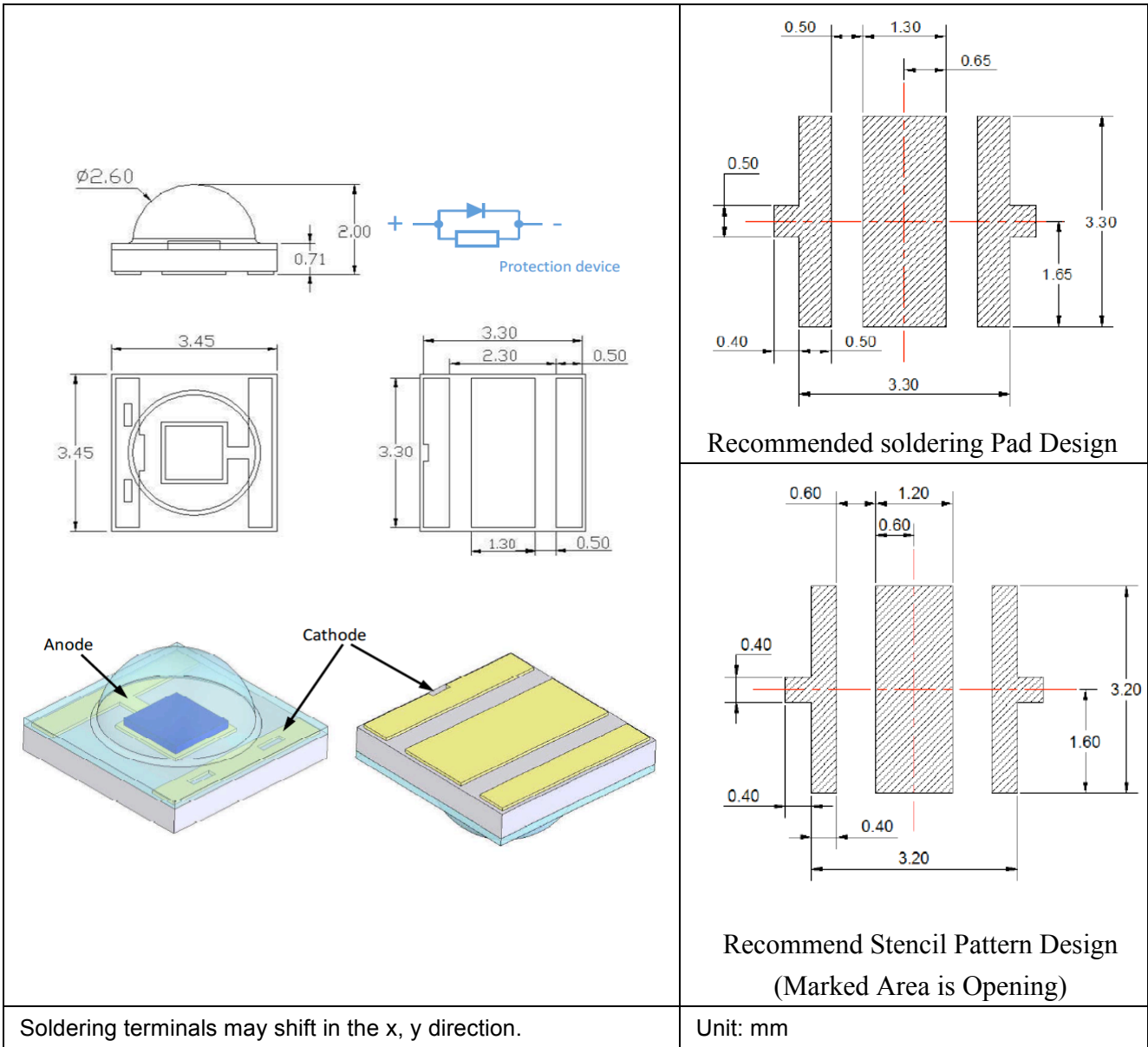

Characteristic Curves

Official Product	Product: IN-3531ACUV	Data Sheet No.
Tentative Product	*****	IN-3531ACUV
Specifications are subject to change without notice. Data and drawings herein are copyrighted.	Jan. 17, 2013	Version of 1.0
		Page 8/13

Relative Spectral Power Distribution, Ta=25 °C

UV

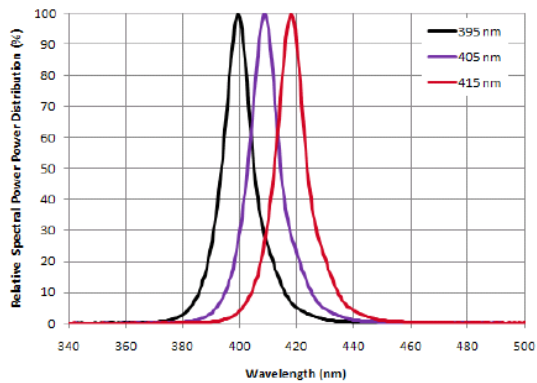
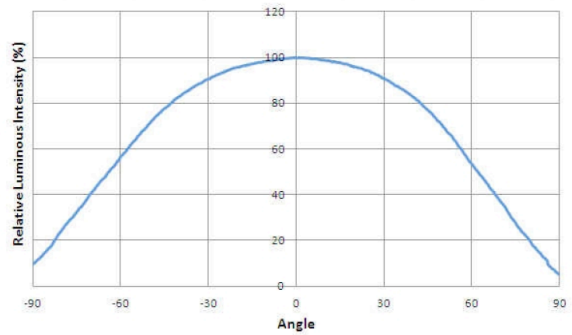
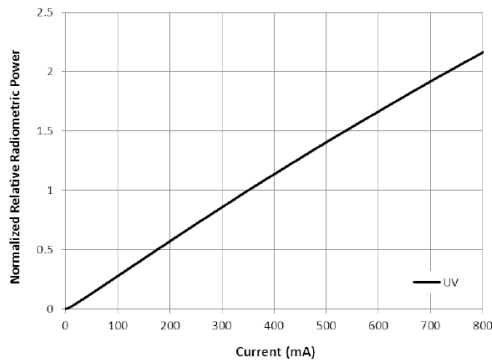
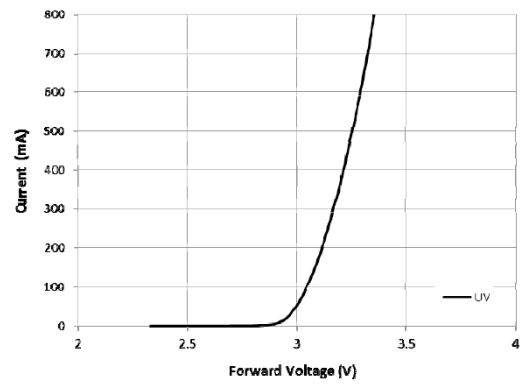
Typical Spatial Radiation Pattern

Typical Forward L-I Characteristics

Typical Forward I-V Characteristics

Thermal Design

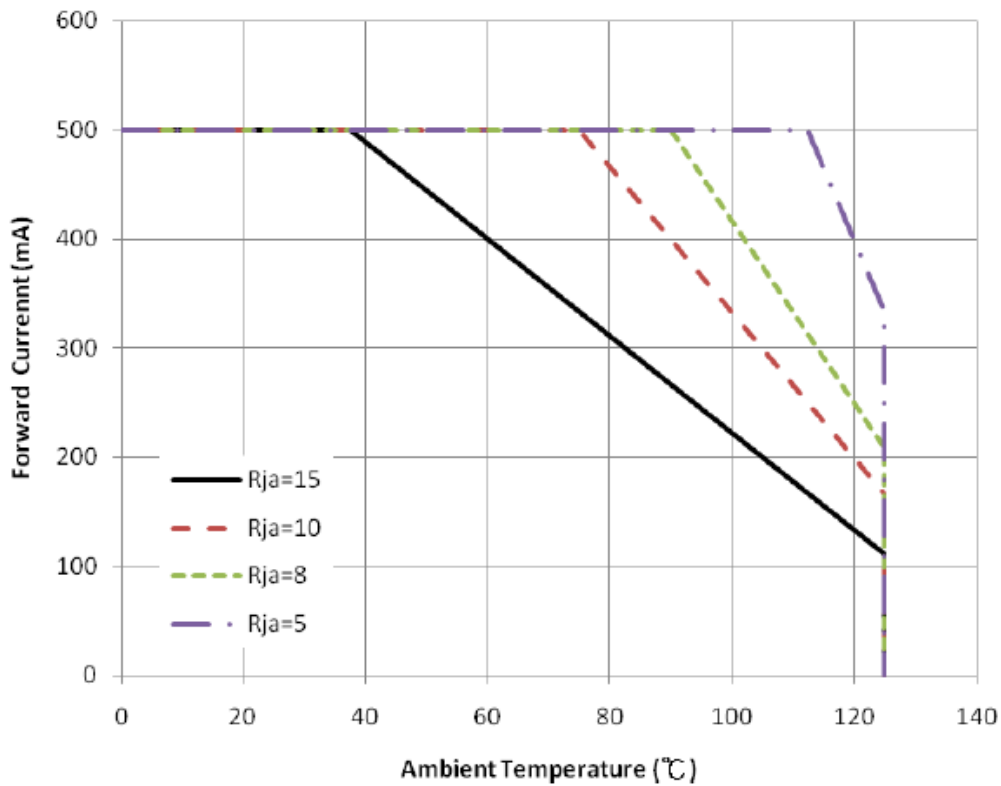
Official Product	Product: IN-3531ACUV	Data Sheet No.
Tentative Product	*****	IN-3531ACUV
Specifications are subject to change without notice. Data and drawings herein are copyrighted.	Jan. 17, 2013	Version of 1.0
		Page 9/13

Thermal design of the end product is important. The thermal resistance between the junction and the solder point (R_{ΘJ-S}) and the end product should be designed to minimize the thermal resistance from the solder point to ambient in order to optimize the emitter life and optical characteristics. The maximum operation current is determined by the plot of Allowable Forward Current vs. Ambient Temperature.



The junction temperature can be correlated to the thermal resistance between the junction and ambient (R_{ja}) by the following equation.

$$T_j = T_a + R_{ja} * W$$

T_j: LED junction temperature

T_a: Ambient temperature

R_{ja}: Thermal resistance between the junction and ambient

W: Input power (I_F*V_F)

Reflow Soldering

Official Product	Product: IN-3531ACUV	Data Sheet No.
Tentative Product	*****	IN-3531ACUV
Specifications are subject to change without notice. Data and drawings herein are copyrighted.	Jan. 17, 2013	Version of 1.0
		Page 10/13

The LEDs can be soldered using the parameter listed below. As a general guideline, the users are suggested to follow the recommended soldering profile provided by the manufacturer of the solder paste. Although the recommended soldering conditions are specified in the list, reflow soldering at the lowest possible temperature is preferred for the LEDs.

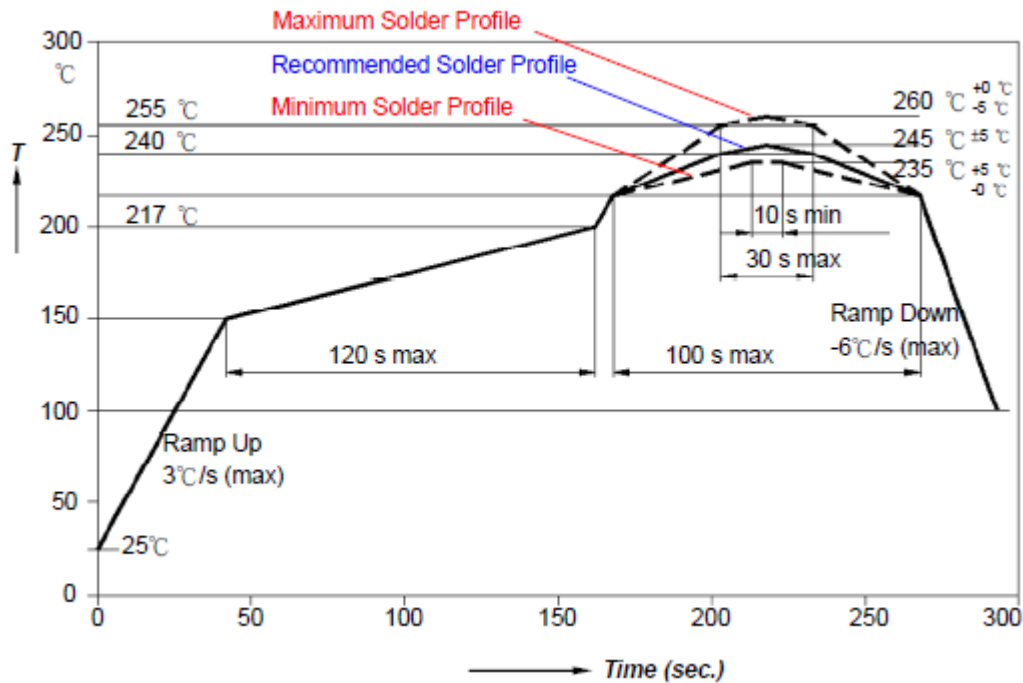

Profile Feature	Sn-Pb Eutectic Assembly	Pb-Free Assembly
Average Ramp-up Rate (T _{smax} to T _p)	3°C/second max.	3°C/second max.
Preheat		
- Temperature Min(T _{smin})	100°C	150°C
- Temperature Max(T _{smax})	150°C	200°C
- Time(t _{smin} to t _{smax})	60-120 seconds	60-180 seconds
Time maintained above:		
- Temperature(T _L)	183°C	217°C
- Time(t _L)	60-150 seconds	60-150 seconds
Peak/classification Temperature(T _p)	215°C	260°C
Time within 5°C of actual Peak Temperature(t _p)	10-30 seconds	20-40 seconds
Ramp-Down Rate	6°C/second max.	6°C/second max.
Time 25°C to Peak Temperature	6 minutes max.	8 minutes max.

Official Product	Product: IN-3531ACUV	Data Sheet No.
Tentative Product	*****	IN-3531ACUV
Specifications are subject to change without notice. Data and drawings herein are copyrighted.	Jan. 17, 2013	Version of 1.0
		Page 11/13

Packing Information

The carrier tape is conformal to EIA-481D

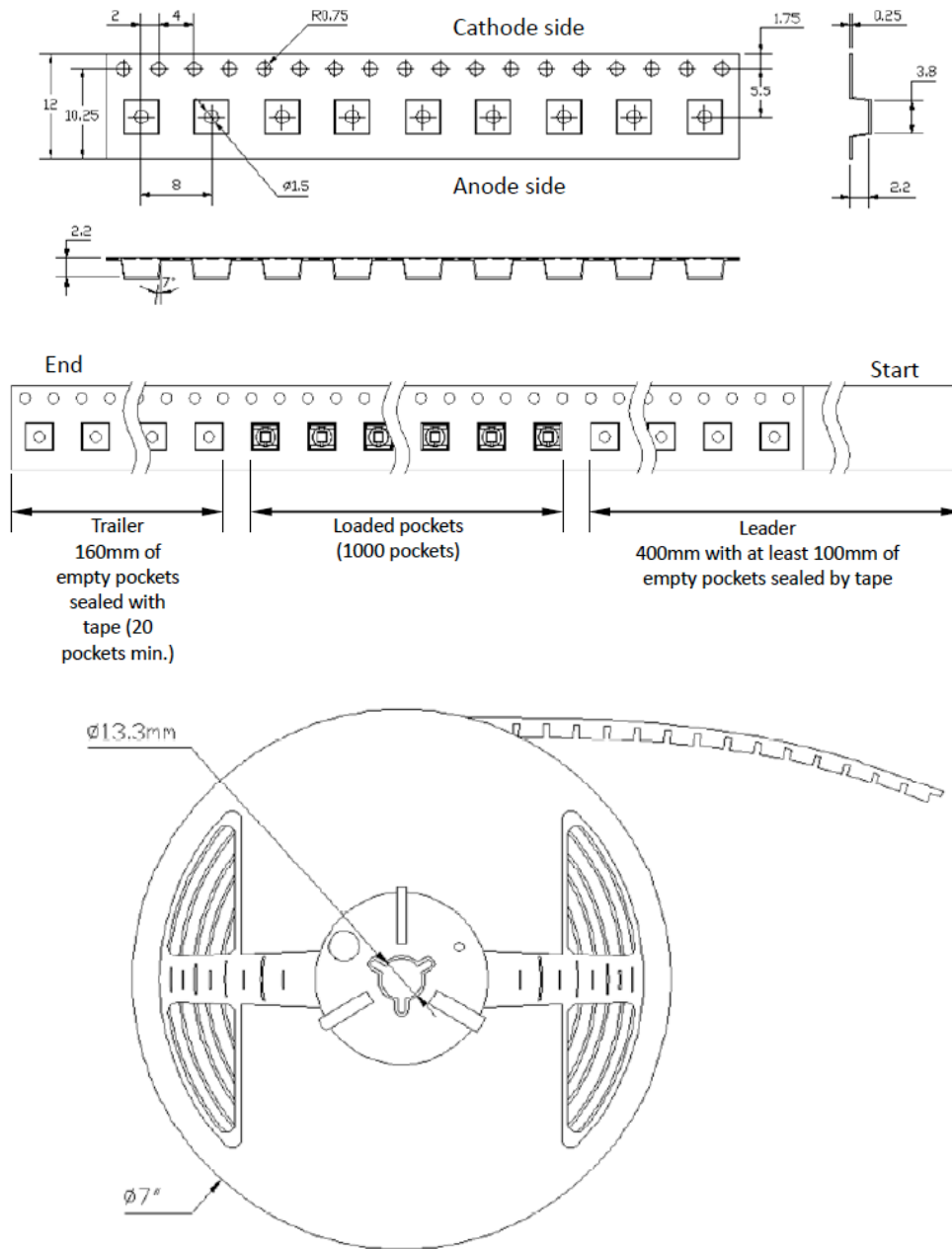

Note : All Dimensions are in millimeter

Official Product	Product: IN-3531ACUV	Data Sheet No.
Tentative Product	*****	IN-3531ACUV
Specifications are subject to change without notice. Data and drawings herein are copyrighted.	Jan. 17, 2013	Version of 1.0
		Page 12/13

Revision History

Changes since last revision	Page	Version No.	Revision Date
Initial release		1.0	01-17-2013

Official Product	Product: IN-3531ACUV		Data Sheet No.
Tentative Product	*****		IN-3531ACUV
Specifications are subject to change without notice. Data and drawings herein are copyrighted.	Jan. 17, 2013	Version of 1.0	Page 13/13



Стандарт Электрон Связь

Мы молодая и активно развивающаяся компания в области поставок электронных компонентов. Мы поставляем электронные компоненты отечественного и импортного производства напрямую от производителей и с крупнейших складов мира.

Благодаря сотрудничеству с мировыми поставщиками мы осуществляем комплексные и плановые поставки широчайшего спектра электронных компонентов.

Собственная эффективная логистика и склад в обеспечивает надежную поставку продукции в точно указанные сроки по всей России.

Мы осуществляем техническую поддержку нашим клиентам и предпродажную проверку качества продукции. На все поставляемые продукты мы предоставляем гарантию .

Осуществляем поставки продукции под контролем ВП МО РФ на предприятия военно-промышленного комплекса России , а также работаем в рамках 275 ФЗ с открытием отдельных счетов в уполномоченном банке. Система менеджмента качества компании соответствует требованиям ГОСТ ISO 9001.

Минимальные сроки поставки, гибкие цены, неограниченный ассортимент и индивидуальный подход к клиентам являются основой для выстраивания долгосрочного и эффективного сотрудничества с предприятиями радиоэлектронной промышленности, предприятиями ВПК и научно-исследовательскими институтами России.

С нами вы становитесь еще успешнее!

Наши контакты:

Телефон: +7 812 627 14 35

Электронная почта: sales@st-electron.ru

Адрес: 198099, Санкт-Петербург,
Промышленная ул, дом № 19, литера Н,
помещение 100-Н Офис 331