

NX3DV642

3-lane high-speed MIPI compatible switch

Rev. 1 — 20 August 2012

Product data sheet

1. General description

The NX3DV642 is a high-speed triple-pole double-throw differential signal switch. The device is optimized for switching between two MIPI devices, such as cameras or LCD displays and on-board multimedia application processors.

The NX3DV642 is compatible with the requirements of Mobile Industry Processor Interface (MIPI). The low capacitance design allows the NX3DV642 to switch signals that exceed 500 MHz in frequency

2. Features and benefits

- Supply voltage range from 2.65 V to 4.3 V
- 7.5 Ω typical ON resistance
- 8.4 pF typical ON capacitance
- 950 MHz typical bandwidth or data frequency
- Low crosstalk of -55 dB at 100 MHz
- Break-before-make switching
- ESD protection:
 - ◆ HBM JESD22-A114F Class 2 exceeds 2000 V
 - ◆ CDM AEC-Q100-011 revision B exceeds 1000 V
 - ◆ HBM exceeds 12000 V for power to GND protection
- Latch-up performance exceeds 100 mA per JESD 78 Class II Level A
- Specified from -40 °C to +85 °C

3. Applications

- Dual camera applications for cell phones
- Dual LCD applications for cell phones, digital camera displays and viewfinders

4. Ordering information

Table 1. Ordering information

Type number	Package			
	Temperature range	Name	Description	Version
NX3DV642GU	-40 °C to +85 °C	XQFN24	plastic, extremely thin quad flat package; no leads; 24 terminals; body 2.5 x 3.4 x 0.5 mm	SOT1310-1



5. Marking

Table 2. Marking

Type number	Marking code
NX3DV642GU	3DV642

6. Functional diagram

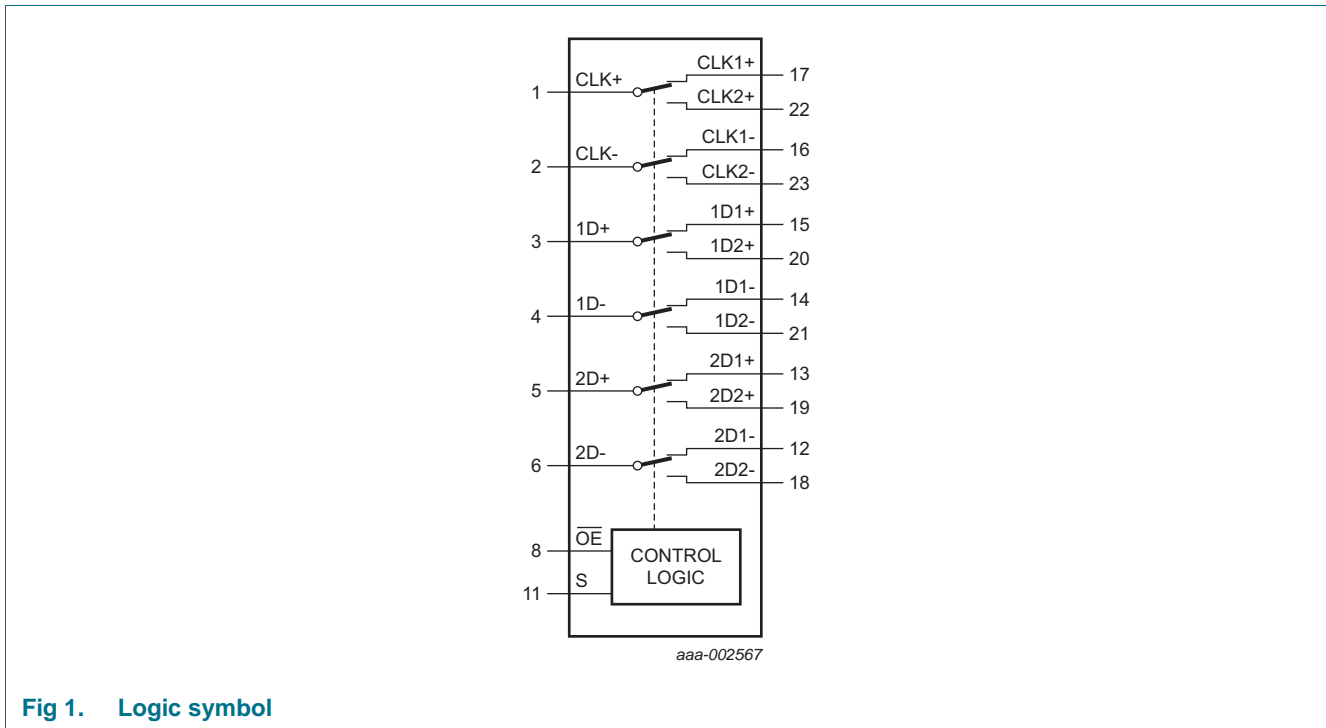

Fig 1. Logic symbol

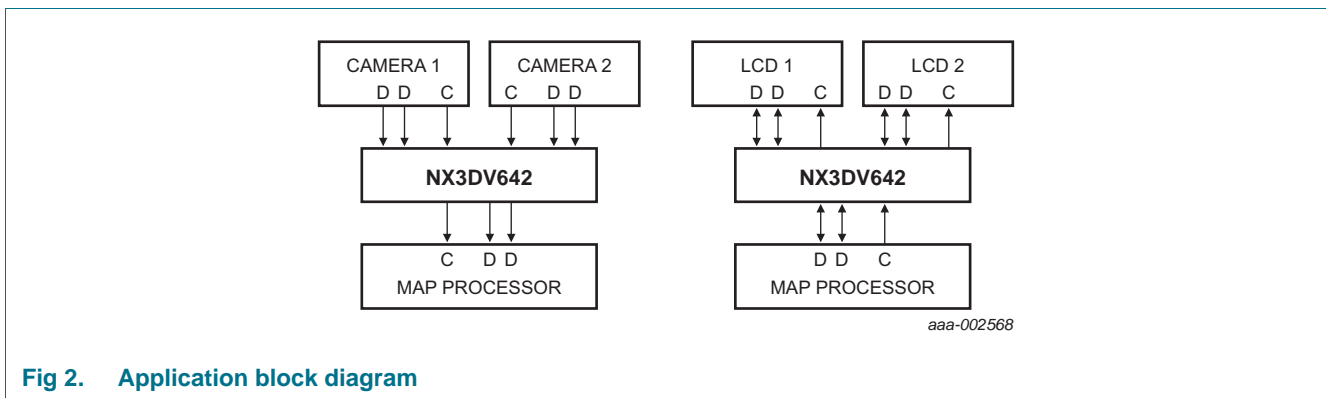

Fig 2. Application block diagram

7. Pinning information

7.1 Pinning

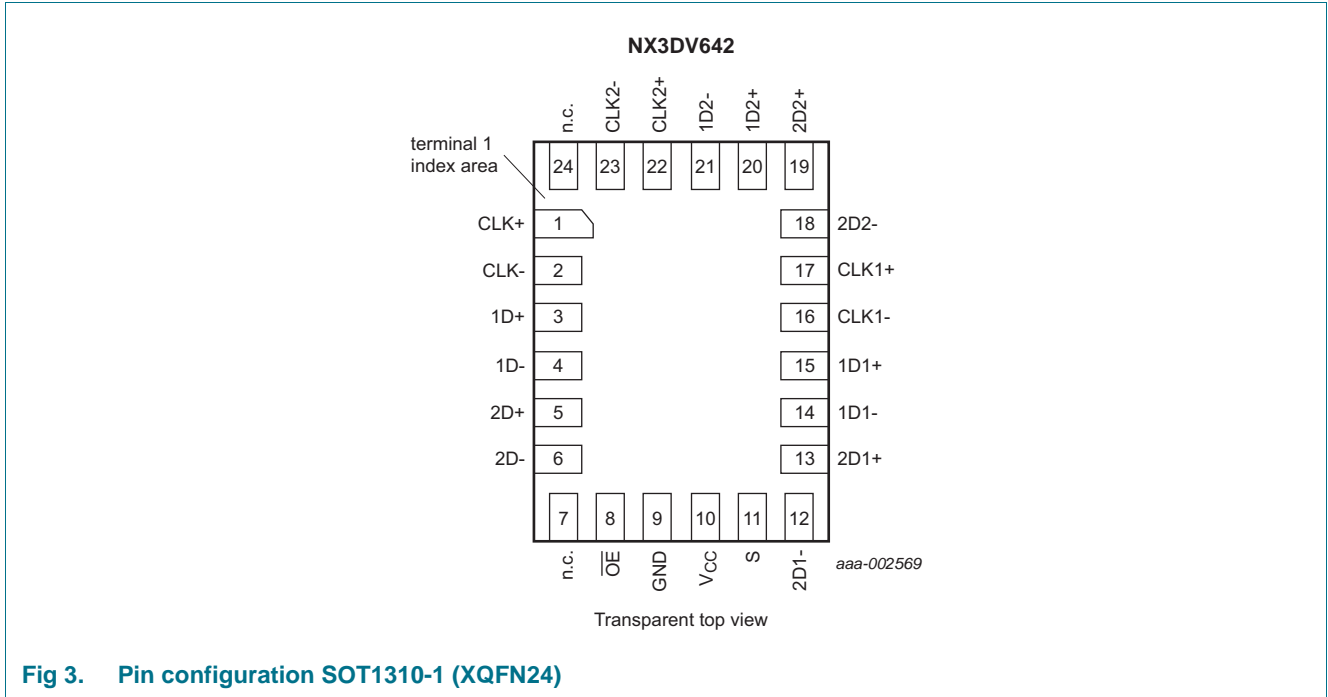

Fig 3. Pin configuration SOT1310-1 (XQFN24)

7.2 Pin description

Table 3. Pin description

Symbol	Pin	Description
CLK+, CLK-	1, 2	common output or input clock path
1D+, 1D-	3, 4	common output or input data path 1D
2D+, 2D-	5, 6	common output or input data path 2D
n.c.	7, 24	not connected
OE	8	output enable input (active LOW)
GND	9	ground (0 V)
V _{CC}	10	supply voltage
S	11	select input
2D1+, 2D1-	13, 12	independent input or output data path 2D1
1D1+, 1D1-	15, 14	independent input or output data path 1D1
CLK1+, CLK1-	17, 16	independent input or output clock path CLK1
2D2+, 2D2-	19, 18	independent input or output data path 2D2
1D2+, 1D2-	20, 21	independent input or output data path 1D2
CLK2+, CLK2-	22, 23	independent input or output clock path CLK2

8. Functional description

Table 4. Function table^[1]

Input		Channel on
S	$\overline{\text{OE}}$	
L	L	CLKn, 1Dn, 2Dn = CLK1n, 1D1n, 2D1n
H	L	CLKn, 1Dn, 2Dn = CLK2n, 1D2n, 2D2n
X	H	switch off

[1] H = HIGH voltage level; L = LOW voltage level; X = don't care. (n = + or -)

9. Limiting values

Table 5. Limiting values

In accordance with the Absolute Maximum Rating System (IEC 60134). Voltages are referenced to GND (ground = 0 V).

Symbol	Parameter	Conditions	Min	Max	Unit
V_{CC}	supply voltage		-0.5	+5.5	V
V_I	input voltage	pins S and $\overline{\text{OE}}$	^[1] -0.5	+5.5	V
V_{SW}	switch voltage		-0.5	+5.5	V
I_{IK}	input clamping current	$V_I < -0.5$ V	-50	-	mA
I_{SK}	switch clamping current	$V_I < -0.5$ V	-50	+50	mA
I_{SW}	switch current		-100	+100	mA
I_{CC}	supply current		-	+50	mA
T_{stg}	storage temperature		-65	+150	°C
P_{tot}	total power dissipation	$T_{amb} = -40$ °C to +85 °C	-	533	mW

[1] The minimum input voltage rating may be exceeded if the input current rating is observed.

10. Recommended operating conditions

Table 6. Recommended operating conditions

Symbol	Parameter	Conditions	Min	Max	Unit
V_{CC}	supply voltage		2.65	4.3	V
V_I	input voltage	pins S and $\overline{\text{OE}}$	0	4.3	V
V_{SW}	switch voltage		^[1] 0	4.5	V
T_{amb}	ambient temperature		-40	+85	°C

[1] To avoid sinking GND current from terminals CLKn, 1Dn and 2Dn when switch current flows in terminals CLK1n, CLK2n, 1D1n 1D2n, 2D1n and 2D2n (n = + or -), the voltage drop across the bidirectional switch must not exceed 0.4 V. If the switch current flows into terminals CLKn, 1Dn and 2Dn, no GND current flows from terminals CLK1n, CLK2n, 1D1n 1D2n, 2D1n and 2D2n. In this case, there is no limit for the voltage drop across the switch.

11. Static characteristics

Table 7. Static characteristics

At recommended operating conditions; voltages are referenced to GND (ground 0 V).

Symbol	Parameter	Conditions	T _{amb} = -40 °C to +85 °C			Unit
			Min	Typ ^[1]	Max	
V _{IH}	HIGH-level input voltage	V _{CC} = 2.65 V to 2.775 V	1.3	-	-	V
		V _{CC} = 4.3 V	1.7	-	-	V
V _{IL}	LOW-level input voltage	V _{CC} = 2.65 V to 2.775 V	-	-	0.5	V
		V _{CC} = 4.3 V	-	-	0.7	V
V _{IK}	input clamping voltage	V _{CC} = 2.775 V; I _I = -18 mA	-1.2	-	-	V
I _I	input leakage current	pins S and \overline{OE} ; V _I = GND to 4.3 V; V _{CC} = 4.3 V	-	-	±1	μA
I _{S(OFF)}	OFF-state leakage current	V _{CC} = 4.3 V; see Figure 4	-	-	±2	μA
I _{OFF}	power-off leakage current	V _I or V _O = 0 V to 4.3 V; V _{CC} = 0 V	-	-	±2	μA
I _{CC}	supply current	V _I = V _{CC} or GND; V _{SW} = GND or V _{CC} ; V _{CC} = 4.3 V	-	-	2	μA
ΔI _{CC}	additional supply current	V _I = 1.8 V; V _{SW} = GND or V _{CC} ; V _{CC} = 2.775 V	-	-	1.5	μA
C _I	input capacitance	pins S and OE	-	1.3	-	pF
C _{S(OFF)}	OFF-state capacitance	pins CLK1n, CLK2n, 1D1n 1D2n, 2D1n and 2D2n; V _I = 0 V to 3.3 V	^[2]	3.0	-	pF
C _{S(ON)}	ON-state capacitance	pins CLKn, 1Dn and 2Dn; V _I = 0 V to 3.3 V	^[2]	8.4	-	pF

[1] Typical values are measured at T_{amb} = 25 °C and V_{CC} = 2.775 V.

[2] n = + or -.

11.1 Test circuits

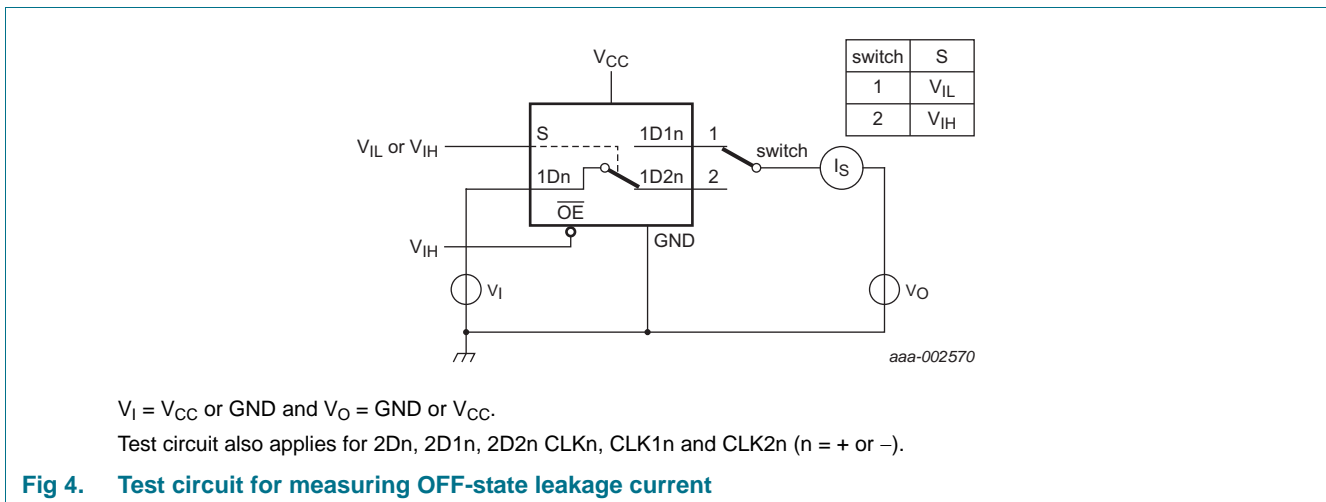

11.2 ON resistance

Table 8. ON resistance

At recommended operating conditions; voltages are referenced to GND (ground = 0 V).

Symbol	Parameter	Conditions	-40 °C to +85 °C			Unit
			Min	Typ ^[1]	Max	
low speed mode						
R _{ON}	ON resistance	V _I = 1.2 V; I _{SW} = 10 mA; see Figure 5 V _{CC} = 2.65 V	-	7.5	14	Ω
ΔR _{ON}	ON resistance mismatch between channels	V _I = 1.2 V; I _{SW} = 10 mA V _{CC} = 2.65 V	-	0.65	-	Ω
High speed mode						
R _{ON}	ON resistance	V _I = 0.1 V; I _{SW} = 10 mA; see Figure 5 V _{CC} = 2.65 V	-	5.5	9.5	Ω
ΔR _{ON}	ON resistance mismatch between channels	V _I = 0.1 V; I _{SW} = 10 mA V _{CC} = 2.65 V	-	0.65	-	Ω

[1] Typical values are measured at T_{amb} = 25 °C.

[2] Measured at identical V_{CC}, temperature and input voltage.

11.3 ON resistance test circuit and graphs

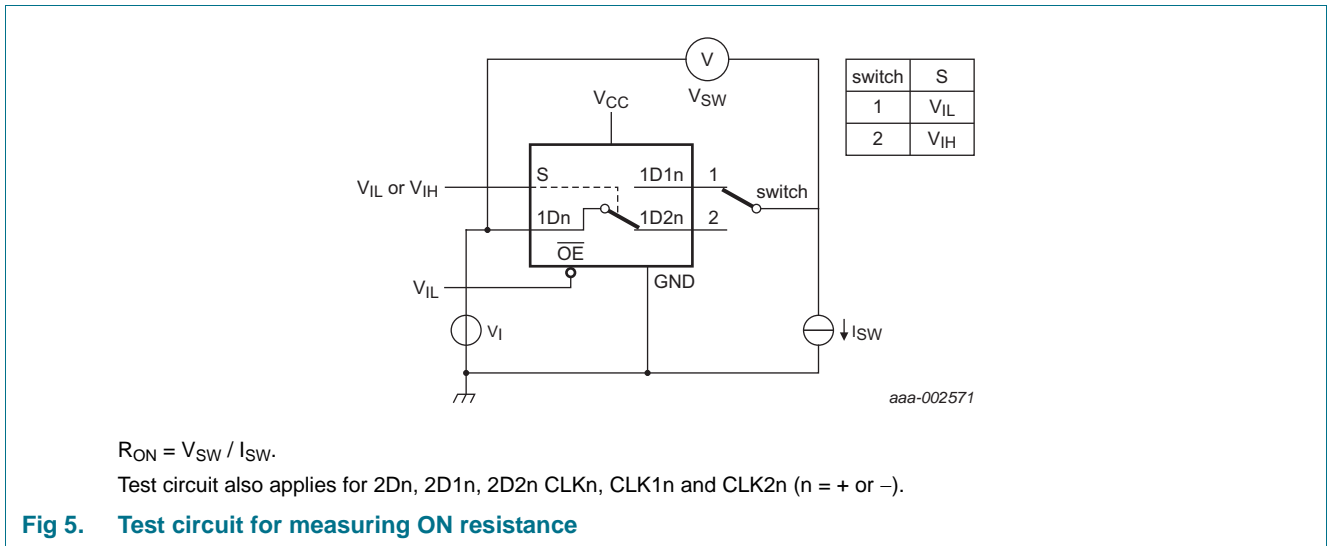

12. Dynamic characteristics

Table 9. Dynamic characteristics

At recommended operating conditions; voltages are referenced to GND (ground = 0 V); for load circuit see [Figure 9](#).

Symbol	Parameter	Conditions	T _{amb} = -40 °C to +85 °C			Unit
			Min	Typ ^[1]	Max	
t _{pd}	propagation delay	CLKn to CLK1n or CLK2n; 1Dn to 1D1n or 1D2n or 2Dn to 2D1n or 2D2n; see Figure 6 ^{[2][3][4]} V _{CC} = 2.775 V	-	0.25	-	ns
t _{en}	enable time	S or \overline{OE} to CLKn, 1Dn or 2Dn; see Figure 7 ^{[2][3]} V _{CC} = 2.65 V to 2.775 V	-	13.5	37	ns
t _{dis}	disable time	S or \overline{OE} to CLKn, 1Dn or 2Dn; see Figure 7 ^{[2][3]} V _{CC} = 2.65 V to 2.775 V	-	5.5	27	ns
t _{b-m}	break-before-make time	see Figure 8 ^[4] V _{CC} = 2.65 V to 2.775 V	3	7	-	ns
t _{sk(p)}	pulse skew time	V _{CC} = 2.65 V to 2.775 V; V _{SW} = 0.2 V (p-p) ^[4]	-	10	-	ps
t _{sk(o)}	output skew time	V _{CC} = 2.65 V to 2.775 V; V _{SW} = 0.2 V (p-p) ^[4]	-	15	-	ps
t _{sk(pr)}	process skew time	V _{CC} = 2.65 V to 2.775 V; V _{SW} = 0.2 V (p-p) ^[4]	-	40	-	ps

[1] Typical values are measured at T_{amb} = 25 °C, C_L = 5 pF and V_{CC} = 2.775 V.

[2] n = + or -.

[3] t_{pd} is the same as t_{PLH} and t_{PHL}.
t_{en} is the same as t_{PZH}
t_{dis} is the same as t_{PHZ}

[4] Guaranteed by design.

12.1 Waveform and test circuits

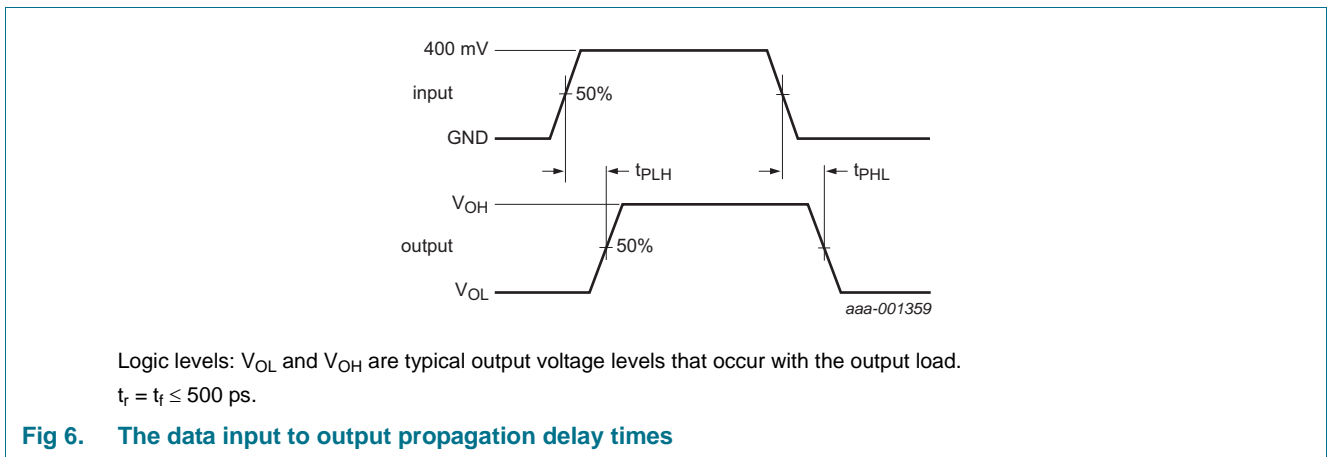

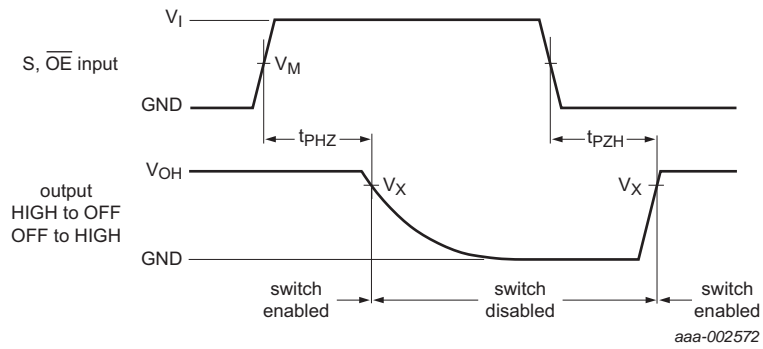

Measurement points are given in [Table 10](#).

Logic level: V_{OH} and V_{OL} are typical output voltage levels that occur with the output load.

Fig 7. Enable and disable times

Table 10. Measurement points

Supply voltage	Input		Output
V_{CC}	V_M	V_I	V_X
2.65 V to 2.775 V	$0.5V_{CC}$	V_{CC}	$0.9V_{OH}$

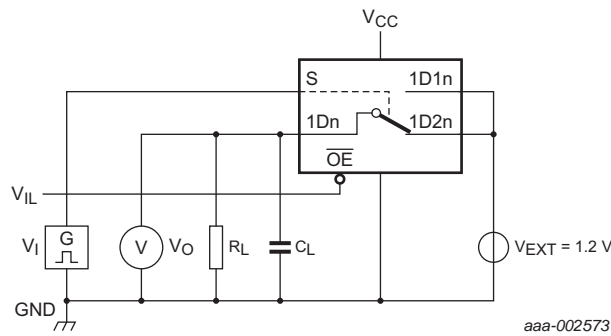

a. Test circuit.

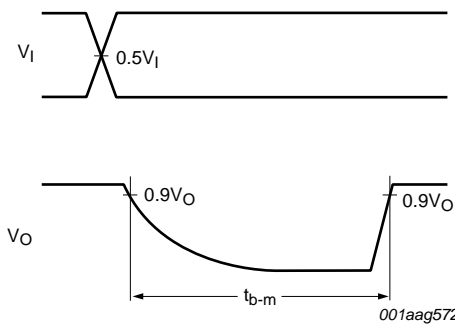

b. Input and output measurement points

Test circuit also applies for 2Dn, 2D1n, 2D2n CLKn, CLK1n and CLK2n (n = + or -).

Fig 8. Test circuit for measuring break-before-make timing

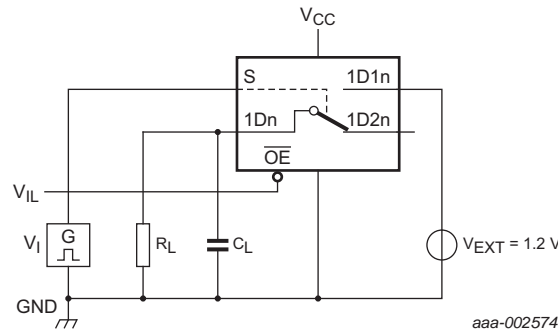

Test circuit also applies for 2Dn, 2D1n, 2D2n CLKn, CLK1n and CLK2n (n = + or -).

Test data is given in [Table 11](#).

Definitions test circuit:

R_T = Termination resistance (should be equal to output impedance Z_o of the pulse generator).

R_L = Load resistance.

C_L = Load capacitance including jig and probe capacitance.

V_{EXT} = External voltage for measuring switching times.

V_I may be connected to S or OE.

Fig 9. Test circuit for measuring switching times

Table 11. Test data

Supply voltage	Input		Load	
V _{CC}	V _I	t _r , t _f	C _L	R _L
2.65 V to 2.775 V	V _{CC}	≤ 2.5 ns	5 pF	50 Ω

12.2 Additional dynamic characteristics

Table 12. Additional dynamic characteristics

At recommended operating conditions; voltages are referenced to GND (ground = 0 V); V_I = GND or V_{CC} (unless otherwise specified); t_r = t_f ≤ 2.5 ns.

Symbol	Parameter	Conditions	T _{amb} = 25 °C			Unit
			Min	Typ	Max	
f _(-3dB)	-3 dB frequency response	R _L = 50 Ω; see Figure 10 C _L = 0 pF; V _{CC} = 2.775 V	-	950	-	MHz
α _{iso}	isolation (OFF-state)	f _i = 100 MHz; R _L = 50 Ω; see Figure 11 V _{CC} = 2.775 V	-	-35	-	dB
Xtalk	crosstalk	between switches; f _i = 100 MHz; R _L = 50 Ω; see Figure 12 V _{CC} = 2.775 V	-	-55	-	dB

[1] f_i is biased at 0.5V_{CC}.

12.3 Test circuits

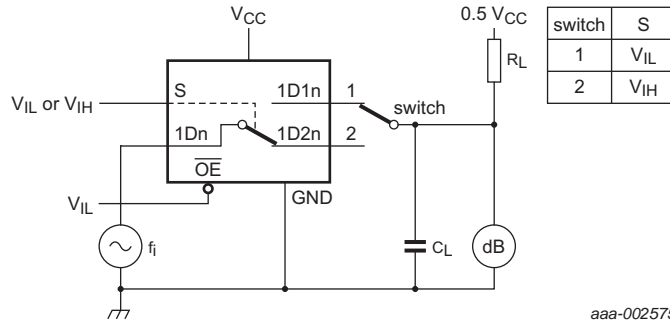

Adjust f_i voltage to obtain 0 dBm level at output. Increase f_i frequency until dB meter reads -3 dB.
 Test circuit also applies for 2Dn, 2D1n, 2D2n CLKn, CLK1n and CLK2n (n = + or -).

Fig 10. Test circuit for measuring the frequency response when channel is in ON-state

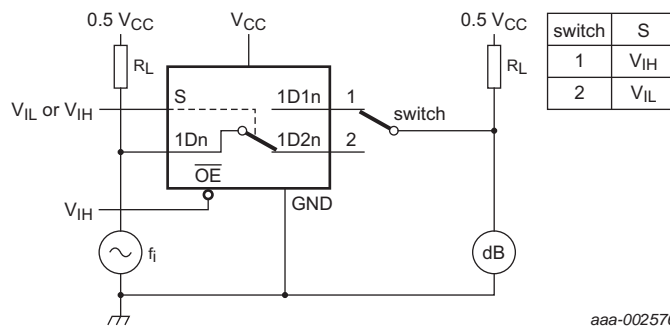

Adjust f_i voltage to obtain 0 dBm level at input.
 Test circuit also applies for 2Dn, 2D1n, 2D2n CLKn, CLK1n and CLK2n (n = + or -).

Fig 11. Test circuit for measuring isolation (OFF-state)

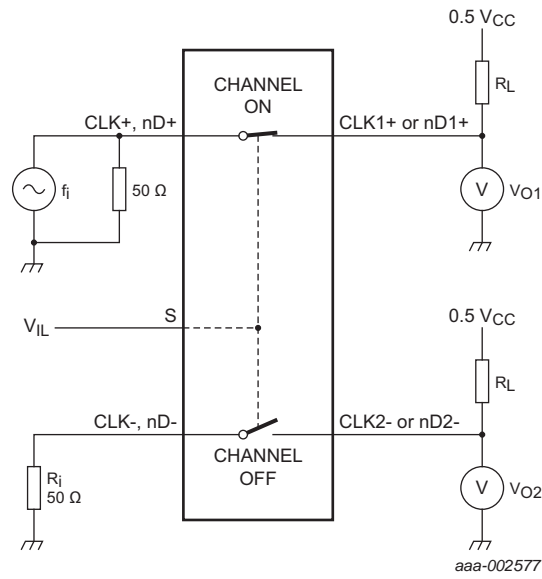

$20 \log_{10} (V_{O2} / V_{O1})$ or $20 \log_{10} (V_{O1} / V_{O2})$.

Fig 12. Test circuit for measuring crosstalk between switches

13. Package outline

XQFN24: plastic, extremely thin quad flat package; no leads; 24 terminals; body 2.5 x 3.4 x 0.5 mm

SOT1310-1

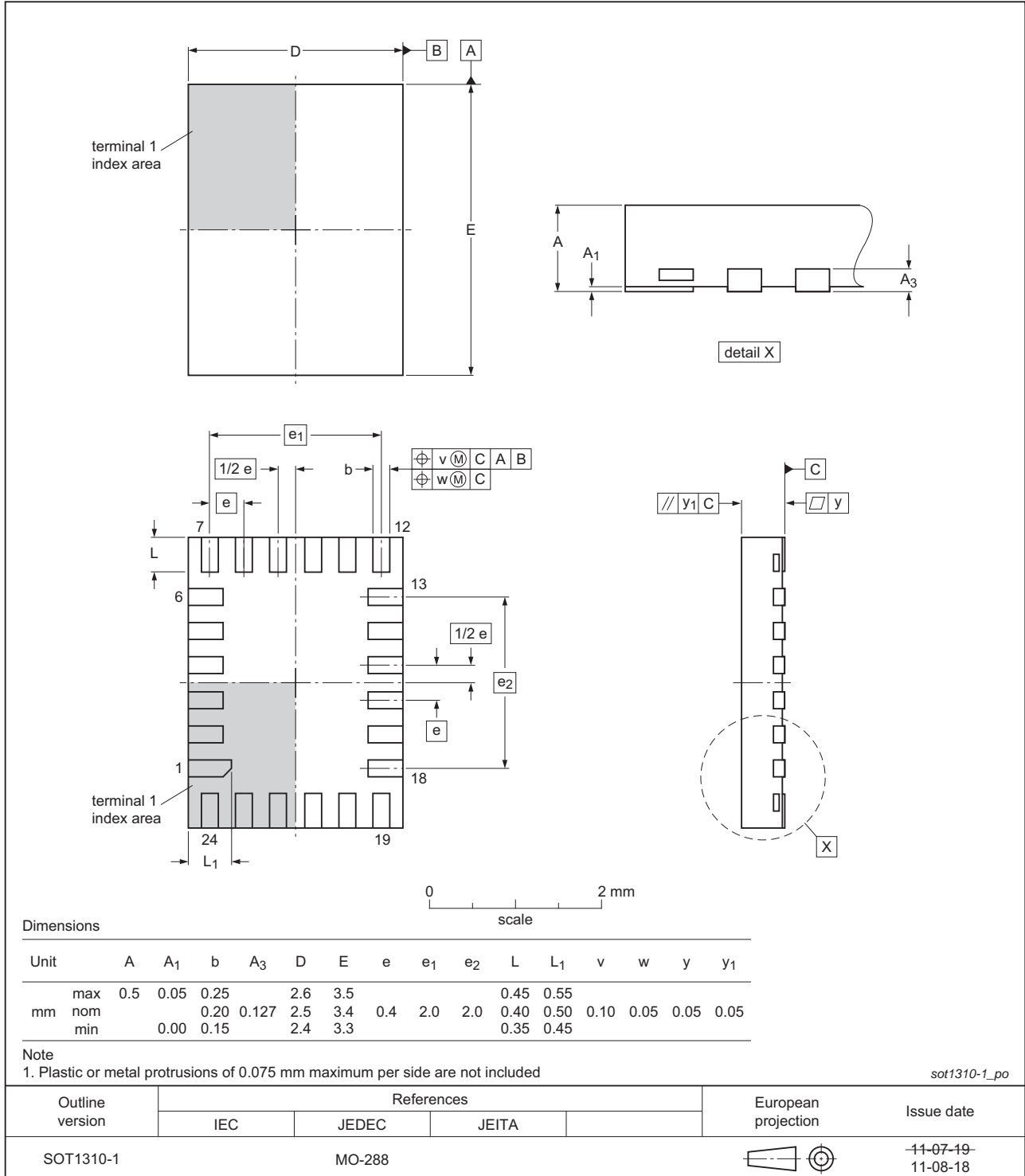

Fig 13. Package outline SOT1310-1 (XQFN24)

14. Abbreviations

Table 13. Abbreviations

Acronym	Description
CDM	Charged Device Model
CMOS	Complementary Metal-Oxide Semiconductor
ESD	ElectroStatic Discharge
HBM	Human Body Model
MM	Machine Model
TTL	Transistor-Transistor Logic

15. Revision history

Table 14. Revision history

Document ID	Release date	Data sheet status	Change notice	Supersedes
NX3DV642 v.1	20120820	Product data sheet	-	-

16. Legal information

16.1 Data sheet status

Document status ^{[1][2]}	Product status ^[3]	Definition
Objective [short] data sheet	Development	This document contains data from the objective specification for product development.
Preliminary [short] data sheet	Qualification	This document contains data from the preliminary specification.
Product [short] data sheet	Production	This document contains the product specification.

[1] Please consult the most recently issued document before initiating or completing a design.

[2] The term 'short data sheet' is explained in section "Definitions".

[3] The product status of device(s) described in this document may have changed since this document was published and may differ in case of multiple devices. The latest product status information is available on the Internet at URL <http://www.nxp.com>.

16.2 Definitions

Draft — The document is a draft version only. The content is still under internal review and subject to formal approval, which may result in modifications or additions. NXP Semiconductors does not give any representations or warranties as to the accuracy or completeness of information included herein and shall have no liability for the consequences of use of such information.

Short data sheet — A short data sheet is an extract from a full data sheet with the same product type number(s) and title. A short data sheet is intended for quick reference only and should not be relied upon to contain detailed and full information. For detailed and full information see the relevant full data sheet, which is available on request via the local NXP Semiconductors sales office. In case of any inconsistency or conflict with the short data sheet, the full data sheet shall prevail.

Product specification — The information and data provided in a Product data sheet shall define the specification of the product as agreed between NXP Semiconductors and its customer, unless NXP Semiconductors and customer have explicitly agreed otherwise in writing. In no event however, shall an agreement be valid in which the NXP Semiconductors product is deemed to offer functions and qualities beyond those described in the Product data sheet.

16.3 Disclaimers

Limited warranty and liability — Information in this document is believed to be accurate and reliable. However, NXP Semiconductors does not give any representations or warranties, expressed or implied, as to the accuracy or completeness of such information and shall have no liability for the consequences of use of such information. NXP Semiconductors takes no responsibility for the content in this document if provided by an information source outside of NXP Semiconductors.

In no event shall NXP Semiconductors be liable for any indirect, incidental, punitive, special or consequential damages (including - without limitation - lost profits, lost savings, business interruption, costs related to the removal or replacement of any products or rework charges) whether or not such damages are based on tort (including negligence), warranty, breach of contract or any other legal theory.

Notwithstanding any damages that customer might incur for any reason whatsoever, NXP Semiconductors' aggregate and cumulative liability towards customer for the products described herein shall be limited in accordance with the *Terms and conditions of commercial sale* of NXP Semiconductors.

Right to make changes — NXP Semiconductors reserves the right to make changes to information published in this document, including without limitation specifications and product descriptions, at any time and without notice. This document supersedes and replaces all information supplied prior to the publication hereof.

Suitability for use — NXP Semiconductors products are not designed, authorized or warranted to be suitable for use in life support, life-critical or safety-critical systems or equipment, nor in applications where failure or malfunction of an NXP Semiconductors product can reasonably be expected to result in personal injury, death or severe property or environmental damage. NXP Semiconductors and its suppliers accept no liability for inclusion and/or use of NXP Semiconductors products in such equipment or applications and therefore such inclusion and/or use is at the customer's own risk.

Applications — Applications that are described herein for any of these products are for illustrative purposes only. NXP Semiconductors makes no representation or warranty that such applications will be suitable for the specified use without further testing or modification.

Customers are responsible for the design and operation of their applications and products using NXP Semiconductors products, and NXP Semiconductors accepts no liability for any assistance with applications or customer product design. It is customer's sole responsibility to determine whether the NXP Semiconductors product is suitable and fit for the customer's applications and products planned, as well as for the planned application and use of customer's third party customer(s). Customers should provide appropriate design and operating safeguards to minimize the risks associated with their applications and products.

NXP Semiconductors does not accept any liability related to any default, damage, costs or problem which is based on any weakness or default in the customer's applications or products, or the application or use by customer's third party customer(s). Customer is responsible for doing all necessary testing for the customer's applications and products using NXP Semiconductors products in order to avoid a default of the applications and the products or of the application or use by customer's third party customer(s). NXP does not accept any liability in this respect.

Limiting values — Stress above one or more limiting values (as defined in the Absolute Maximum Ratings System of IEC 60134) will cause permanent damage to the device. Limiting values are stress ratings only and (proper) operation of the device at these or any other conditions above those given in the Recommended operating conditions section (if present) or the Characteristics sections of this document is not warranted. Constant or repeated exposure to limiting values will permanently and irreversibly affect the quality and reliability of the device.

Terms and conditions of commercial sale — NXP Semiconductors products are sold subject to the general terms and conditions of commercial sale, as published at <http://www.nxp.com/profile/terms>, unless otherwise agreed in a valid written individual agreement. In case an individual agreement is concluded only the terms and conditions of the respective agreement shall apply. NXP Semiconductors hereby expressly objects to applying the customer's general terms and conditions with regard to the purchase of NXP Semiconductors products by customer.

No offer to sell or license — Nothing in this document may be interpreted or construed as an offer to sell products that is open for acceptance or the grant, conveyance or implication of any license under any copyrights, patents or other industrial or intellectual property rights.

Export control — This document as well as the item(s) described herein may be subject to export control regulations. Export might require a prior authorization from competent authorities.

Non-automotive qualified products — Unless this data sheet expressly states that this specific NXP Semiconductors product is automotive qualified, the product is not suitable for automotive use. It is neither qualified nor tested in accordance with automotive testing or application requirements. NXP Semiconductors accepts no liability for inclusion and/or use of non-automotive qualified products in automotive equipment or applications.

In the event that customer uses the product for design-in and use in automotive applications to automotive specifications and standards, customer (a) shall use the product without NXP Semiconductors' warranty of the product for such automotive applications, use and specifications, and (b) whenever customer uses the product for automotive applications beyond

NXP Semiconductors' specifications such use shall be solely at customer's own risk, and (c) customer fully indemnifies NXP Semiconductors for any liability, damages or failed product claims resulting from customer design and use of the product for automotive applications beyond NXP Semiconductors' standard warranty and NXP Semiconductors' product specifications.

Translations — A non-English (translated) version of a document is for reference only. The English version shall prevail in case of any discrepancy between the translated and English versions.

16.4 Trademarks

Notice: All referenced brands, product names, service names and trademarks are the property of their respective owners.

17. Contact information

For more information, please visit: <http://www.nxp.com>

For sales office addresses, please send an email to: salesaddresses@nxp.com

18. Contents

1	General description	1
2	Features and benefits	1
3	Applications	1
4	Ordering information	1
5	Marking	2
6	Functional diagram	2
7	Pinning information	3
7.1	Pinning	3
7.2	Pin description	3
8	Functional description	4
9	Limiting values	4
10	Recommended operating conditions	4
11	Static characteristics	5
11.1	Test circuits	5
11.2	ON resistance	6
11.3	ON resistance test circuit and graphs	6
12	Dynamic characteristics	7
12.1	Waveform and test circuits	7
12.2	Additional dynamic characteristics	9
12.3	Test circuits	10
13	Package outline	12
14	Abbreviations	13
15	Revision history	13
16	Legal information	14
16.1	Data sheet status	14
16.2	Definitions	14
16.3	Disclaimers	14
16.4	Trademarks	15
17	Contact information	15
18	Contents	16

Please be aware that important notices concerning this document and the product(s) described herein, have been included in section 'Legal information'.

© NXP B.V. 2012.

All rights reserved.

For more information, please visit: <http://www.nxp.com>

For sales office addresses, please send an email to: salesaddresses@nxp.com

Date of release: 20 August 2012

Document identifier: NX3DV642



Стандарт Электрон Связь

Мы молодая и активно развивающаяся компания в области поставок электронных компонентов. Мы поставляем электронные компоненты отечественного и импортного производства напрямую от производителей и с крупнейших складов мира.

Благодаря сотрудничеству с мировыми поставщиками мы осуществляем комплексные и плановые поставки широчайшего спектра электронных компонентов.

Собственная эффективная логистика и склад в обеспечивает надежную поставку продукции в точно указанные сроки по всей России.

Мы осуществляем техническую поддержку нашим клиентам и предпродажную проверку качества продукции. На все поставляемые продукты мы предоставляем гарантию .

Осуществляем поставки продукции под контролем ВП МО РФ на предприятия военно-промышленного комплекса России , а также работаем в рамках 275 ФЗ с открытием отдельных счетов в уполномоченном банке. Система менеджмента качества компании соответствует требованиям ГОСТ ISO 9001.

Минимальные сроки поставки, гибкие цены, неограниченный ассортимент и индивидуальный подход к клиентам являются основой для выстраивания долгосрочного и эффективного сотрудничества с предприятиями радиоэлектронной промышленности, предприятиями ВПК и научно-исследовательскими институтами России.

С нами вы становитесь еще успешнее!

Наши контакты:

Телефон: +7 812 627 14 35

Электронная почта: sales@st-electron.ru

Адрес: 198099, Санкт-Петербург,
Промышленная ул, дом № 19, литера Н,
помещение 100-Н Офис 331