

High Speed Optocoupler, 100 kBd, Low Input Current, High Gain

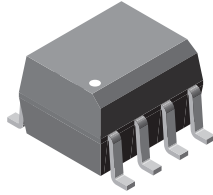

i179074

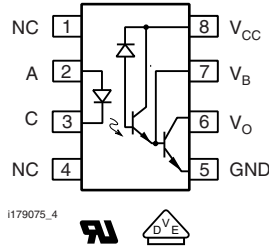

i179075_4

FEATURES

- Industry standard SOIC-8 surface mountable package
- High current transfer ratio, 800 %
- Low input current, 0.5 mA
- High output current, 60 mA
- Isolation test voltage, 4000 V_{RMS}
- TTL compatible output, V_{OL} = 0.1 V
- Adjustable bandwidth access to base
- Compliant to RoHS Directive 2002/95/EC and in accordance to WEEE 2002/96/EC

RoHS
COMPLIANT

DESCRIPTION

Very high current ratio together with 4000 V_{RMS} isolation are achieved by coupling an LED with an integrated high gain photo detector in a SOIC-8 package. Separate pins for the photo diode and output stage enable TTL compatible saturation voltages with high speed operation. Photodarlington operation is achieved by tying the V_{CC} and V_O terminals together. Access to the base terminal allows adjustment to the gain bandwidth.

The SFH6318T is ideal for TTL applications since the 300 % minimum current transfer ratio with an LED current of 1.6 mA enables operation with one unit load-in and one unit load-out with a 2.2 kΩ pull-up resistor.

The SFH6319T is best suited for low power logic applications involving CMOS and low power TTL. A 400 % current transfer ratio with only 0.5 mA of LED current is guaranteed from 0 °C to 70 °C.

Caution:

Due to the small geometries of this device, it should be handled with electrostatic discharge (ESD) precautions. Proper grounding would prevent damage further and/or degradation which may be induced by ESD.

APPLICATIONS

- Logic ground isolation -TTL/TTL, TTL/CMOS, CMOS/CMOS, CMOS/TTL
- EIA RS 232C line receiver
- Low input current line receiver long lines, party lines
- Telephone ring detector
- 117 VAC line voltage status indication - low input power dissipation
- Low power systems - ground isolation

AGENCY APPROVALS

- UL1577, file no. E52744 system code H or J, double protection
- DIN EN 60747-5-5 (VDE 0884) available with option 1
- CSA 93751

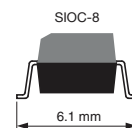
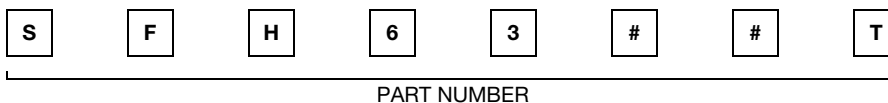
ORDERING INFORMATION

AGENCY CERTIFIED/ PACKAGE	CTR (%)	
UL, CSA	≥ 300	≥ 500
SOIC-8	SFH6318T ⁽¹⁾	SFH6319T ⁽¹⁾
SOIC-8, tube	SFH6318	SFH6319

Note

⁽¹⁾ Available in tubes and in tape and reel

ABSOLUTE MAXIMUM RATINGS (T_{amb} = 25 °C, unless otherwise specified)

PARAMETER	TEST CONDITION	PART	SYMBOL	VALUE	UNIT
INPUT					
Reverse voltage			V _R	3	V
Supply and output voltage	V _{CC} (pin 8 to 5), V _O (pin 6 to 5)	SFH6318T	V _{CC} , V _O	- 0.5 to 7	V
		SFH6319T	V _{CC} , V _O	- 0.5 to 18	V
Input power dissipation			P _{diss}	35	mW

ABSOLUTE MAXIMUM RATINGS ($T_{amb} = 25\text{ }^{\circ}\text{C}$, unless otherwise specified)					
PARAMETER	TEST CONDITION	PART	SYMBOL	VALUE	UNIT
INPUT					
Derate linearly above				50	$^{\circ}\text{C}$
Free air temperature				0.7	$\text{mW}/^{\circ}\text{C}$
Average input current			$I_{F(AVG)}$	20	mA
Peak input current	50 % duty cycle - 1 ms pulse width		I_{FRM}	40	mA
Peak transient input current	$t_p \leq 1\text{ }\mu\text{s}$, 300 pps		I_{FSM}	1	A
OUTPUT					
Output current (pin 6)			I_O	60	mA
Emitter-base reverse current (pin 5 to 7)				0.5	V
Output power dissipation			P_{diss}	150	mW
Derate linearly from $25\text{ }^{\circ}\text{C}$				2	$\text{mW}/^{\circ}\text{C}$
COUPLER					
Isolation test voltage between emitter and detector			V_{ISO}	4000	V_{RMS}
Storage temperature			T_{stg}	- 55 to + 125	$^{\circ}\text{C}$
Lead soldering temperature ⁽¹⁾	$t = 10\text{ s}$		T_{sld}	260	$^{\circ}\text{C}$
Junction temperature			T_j	100	$^{\circ}\text{C}$
Ambient temperature range			T_{amb}	- 55 to + 100	$^{\circ}\text{C}$
Pollution degree (DIN VDE 0110)				2	
Creepage distance				≥ 4	mm
Clearance distance				≥ 4	mm
Comparative tracking index per DIN IEC112/VDE 0303, part 1			CTI	175	
Isolation resistance	$V_{IO} = 500\text{ V}$, $T_{amb} = 25\text{ }^{\circ}\text{C}$		R_{IO}	$\geq 10^{12}$	Ω
	$V_{IO} = 500\text{ V}$, $T_{amb} = 100\text{ }^{\circ}\text{C}$		R_{IO}	$\geq 10^{11}$	Ω

Notes

- Stresses in excess of the absolute maximum ratings can cause permanent damage to the device. Functional operation of the device is not implied at these or any other conditions in excess of those given in the operational sections of this document. Exposure to absolute maximum ratings for extended periods of the time can adversely affect reliability.

⁽¹⁾ Refer to reflow profile soldering conditions for surface mounted devices.

ELECTRICAL CHARACTERISTICS ($T_{amb} = 25\text{ }^{\circ}\text{C}$, unless otherwise specified)						
PARAMETER	TEST CONDITION	SYMBOL	MIN.	TYP.	MAX.	UNIT
INPUT						
Forward voltage	$I_F = 1.6\text{ mA}$	V_F		1.4	1.7	V
Temperature coefficient, forward voltage	$I_F = 1.6\text{ mA}$	$\Delta V_F/\Delta T_{amb}$		- 1.8		$\text{mV}/^{\circ}\text{C}$
OUTPUT						
Logic low output voltage ⁽¹⁾	$I_F = 1.6\text{ mA}$, $I_O = 4.8\text{ mA}$, $V_{CC} = 4.5\text{ V}$	V_{OL}		0.1	0.4	V
	$I_F = 1.6\text{ mA}$, $I_O = 8\text{ mA}$, $V_{CC} = 4.5\text{ V}$	V_{OL}		0.1	0.4	V
	$I_F = 5\text{ mA}$, $I_O = 15\text{ mA}$, $V_{CC} = 4.5\text{ V}$	V_{OL}		0.15	0.4	V
	$I_F = 12\text{ mA}$, $I_O = 24\text{ mA}$, $V_{CC} = 4.5\text{ V}$	V_{OL}		0.25	0.4	V
Logic high output current ⁽¹⁾	$I_F = 0\text{ mA}$, $V_O = V_{CC} = 7\text{ V}$	I_{IO}		0.1	250	μA
	$I_F = 0\text{ mA}$, $V_O = V_{CC} = 18\text{ V}$	I_{IO}		0.05	100	μA
Logic low supply current ⁽¹⁾	$I_F = 1.6\text{ mA}$, $V_O = \text{OPEN}$, $V_{CC} = 18\text{ V}$	I_{CCL}		0.2	1.5	mA
Logic high supply current ⁽¹⁾	$I_F = 0\text{ mA}$, $V_O = \text{OPEN}$, $V_{CC} = 18\text{ V}$	I_{CCH}		0.01	10	μA

ELECTRICAL CHARACTERISTICS ($T_{amb} = 25\text{ }^{\circ}\text{C}$, unless otherwise specified)						
PARAMETER	TEST CONDITION	SYMBOL	MIN.	TYP.	MAX.	UNIT
COUPLER						
Capacitance (input to output) ⁽²⁾	$f = 1\text{ MHz}$	C_{IO}		0.6		pF
Input capacitance	$f = 1\text{ MHz}, V_F = 0$	C_{IN}		25		pF
Resistance (input to output) ⁽²⁾	$V_{IO} = 500\text{ VDC}, T_{amb} = 25\text{ }^{\circ}\text{C}$	R_{IO}		10^{12}		Ω
	$V_{IO} = 500\text{ VDC}, T_{amb} = 100\text{ }^{\circ}\text{C}$	R_{IO}		10^{11}		Ω

Notes

- Minimum and maximum values are testing requirements. Typical values are characteristics of the device and are the result of engineering evaluation. Typical values are for information only and are not part of the testing requirements.
 $T_{amb} = 0\text{ }^{\circ}\text{C}$ to $70\text{ }^{\circ}\text{C}$. Typical values are specified at $T_{amb} = 25\text{ }^{\circ}\text{C}$.
- (1) Pin 7 open.
- (2) Device considered a two-terminal device: pins 1, 2, 3 and 4 shorted together and pins 5, 6, 7 and 8 shorted together.

CURRENT TRANSFER RATIO							
PARAMETER	TEST CONDITION	PART	SYMBOL	MIN.	TYP.	MAX.	UNIT
Current transfer ratio	$I_F = 1.6\text{ mA}, V_O = 0.4\text{ V}, V_{CC} = 4.5\text{ V}$	SFH6318T	CTR	300	1600	2600	%
	$I_F = 0.5\text{ mA}, V_O = 0.4\text{ V}, V_{CC} = 4.5\text{ V}$	SFH6319T	CTR	400	2000	3500	%
	$I_F = 1.6\text{ mA}, V_O = 0.4\text{ V}, V_{CC} = 4.5\text{ V}$	SFH6319T	CTR	500	1600	2600	%

Note

- $T_{amb} = 0\text{ }^{\circ}\text{C}$ to $70\text{ }^{\circ}\text{C}$. Typical values are specified at $T_{amb} = 25\text{ }^{\circ}\text{C}$.
DC current transfer ratio is defined as the ratio of output collector current, I_O , to the forward LED input current, I_F times 100 %. Pin 7 open.

SWITCHING CHARACTERISTICS ($T_{amb} = 25\text{ }^{\circ}\text{C}$, unless otherwise specified)							
PARAMETER	TEST CONDITION	PART	SYMBOL	MIN.	TYP.	MAX.	UNIT
Propagation delay time to logic low at output	$I_F = 1.6\text{ mA}, R_L = 2.2\text{ k}\Omega$	SFH6318T	t_{PHL}		2	10	μs
Propagation delay time to logic low at output ⁽²⁾	$I_F = 0.5\text{ mA}, R_L = 4.7\text{ k}\Omega$	SFH6319T	t_{PHL}		6	25	μs
Propagation delay time to logic low at output	$I_F = 12\text{ mA}, R_L = 270\text{ }\Omega$	SFH6319T	t_{PHL}		0.6	1	μs
Propagation delay time to logic high at output	$I_F = 1.6\text{ mA}, R_L = 2.2\text{ k}\Omega$	SFH6318T	t_{PLH}		2	35	μs
Propagation delay time to logic high at output ⁽²⁾	$I_F = 0.5\text{ mA}, R_L = 4.7\text{ k}\Omega$	SFH6319T	t_{PLH}		4	60	μs
Propagation delay time to logic high at output	$I_F = 12\text{ mA}, R_L = 270\text{ }\Omega$	SFH6319T	t_{PLH}		1.5	7	μs

Note

- (1) Pin 7 open. Using a resistor between pin 5 and 7 will decrease gain and delay time.

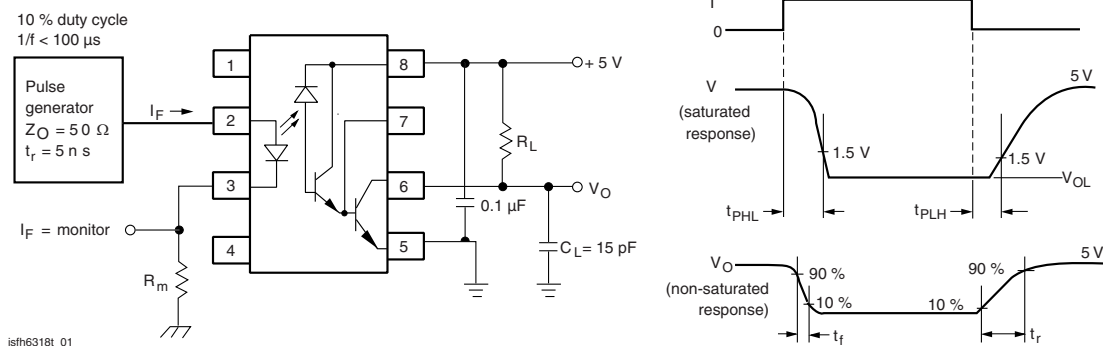

Fig. 1 - Switching Test Circuit

COMMON MODE TRANSIENT IMMUNITY						
PARAMETER	TEST CONDITION	SYMBOL	MIN.	TYP.	MAX.	UNIT
Common mode transient immunity at logic high level output	$I_F = 0 \text{ mA}$, $R_L = 2.2 \text{ k}\Omega$, $V_{CM} = 10 \text{ V}_{P-P}$	$ CM_H $		1K		$\text{V}/\mu\text{s}$
Common mode transient immunity at logic low level output	$I_F = 1.6 \text{ mA}$, $R_L = 2.2 \text{ k}\Omega$, $V_{CM} = 10 \text{ V}_{P-P}$	$ CM_H $		1K		$\text{V}/\mu\text{s}$

Note

- Common mode transient immunity in logic high level is the maximum tolerable (positive) dV_{cm}/dt on the leading edge of the common mode pulse, V_{CM} , to assure that the output will remain in a logic high state (i.e. $V_O > 2 \text{ V}$) common mode transient immunity in logic low level is the maximum tolerable (negative) dV_{cm}/dt on the trailing edge of the common mode pulse signal, V_{CM} , to assure that the output will remain in a logic low state (i.e. $V_O < 0.8 \text{ V}$).
In applications where dv/dt may exceed $50,000 \text{ V}/\mu\text{s}$ (such as state discharge) a series resistor, R_{CC} should be included to protect I_C from destructively high surge currents. The recommended value is refer to figure 2.
 $R_{CC} \cong [(IV)/0.15 I_F (\text{mA})] \text{ k}\Omega$.

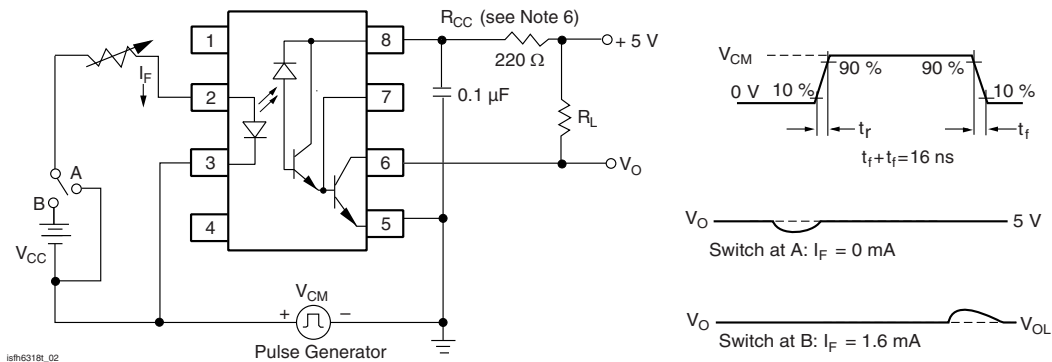

Fig. 2 - Test Circuit for Transient Immunity and Typical Waveforms

SAFETY AND INSULATION RATINGS						
PARAMETER	TEST CONDITION	SYMBOL	MIN.	TYP.	MAX.	UNIT
Climatic Classification (according to IEC 68 part 1)				55/100/21		
Comparative Tracking Index		CTI	175		399	
V_{IOTM}			6000			V
V_{IORM}			560			V
P_{SO}					350	mW
I_{SI}					150	mA
T_{SI}					165	$^{\circ}\text{C}$
Creepage distance			4			mm
Clearance distance			4			mm
Insulation thickness			0.2			mm

Note

- As per IEC 60747-5-5, §7.4.3.8.1, this optocoupler is suitable for “safe electrical insulation” only within the safety ratings. Compliance with the safety ratings shall be ensured by means of protective circuits.



SFH6318T, SFH6319T

High Speed Optocoupler, 100 kBd, Vishay Semiconductors
Low Input Current, High Gain

PACKAGE DIMENSIONS in millimeters

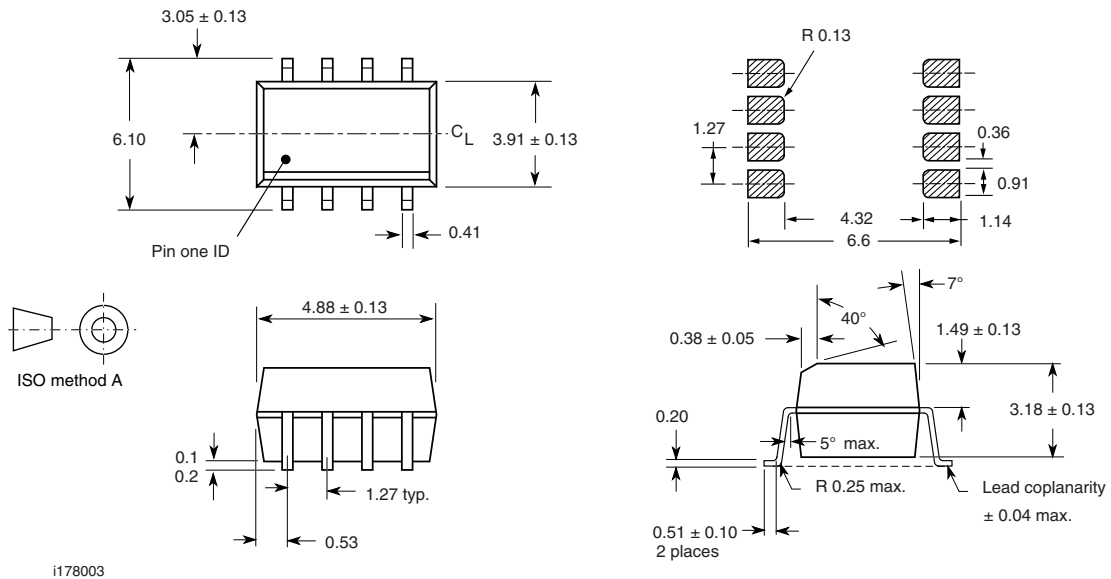

PACKAGE MARKING

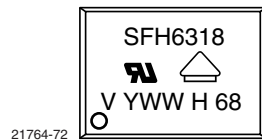



Disclaimer

ALL PRODUCT, PRODUCT SPECIFICATIONS AND DATA ARE SUBJECT TO CHANGE WITHOUT NOTICE TO IMPROVE RELIABILITY, FUNCTION OR DESIGN OR OTHERWISE.

Vishay Intertechnology, Inc., its affiliates, agents, and employees, and all persons acting on its or their behalf (collectively, "Vishay"), disclaim any and all liability for any errors, inaccuracies or incompleteness contained in any datasheet or in any other disclosure relating to any product.

Vishay makes no warranty, representation or guarantee regarding the suitability of the products for any particular purpose or the continuing production of any product. To the maximum extent permitted by applicable law, Vishay disclaims (i) any and all liability arising out of the application or use of any product, (ii) any and all liability, including without limitation special, consequential or incidental damages, and (iii) any and all implied warranties, including warranties of fitness for particular purpose, non-infringement and merchantability.

Statements regarding the suitability of products for certain types of applications are based on Vishay's knowledge of typical requirements that are often placed on Vishay products in generic applications. Such statements are not binding statements about the suitability of products for a particular application. It is the customer's responsibility to validate that a particular product with the properties described in the product specification is suitable for use in a particular application. Parameters provided in datasheets and/or specifications may vary in different applications and performance may vary over time. All operating parameters, including typical parameters, must be validated for each customer application by the customer's technical experts. Product specifications do not expand or otherwise modify Vishay's terms and conditions of purchase, including but not limited to the warranty expressed therein.

Except as expressly indicated in writing, Vishay products are not designed for use in medical, life-saving, or life-sustaining applications or for any other application in which the failure of the Vishay product could result in personal injury or death. Customers using or selling Vishay products not expressly indicated for use in such applications do so at their own risk. Please contact authorized Vishay personnel to obtain written terms and conditions regarding products designed for such applications.

No license, express or implied, by estoppel or otherwise, to any intellectual property rights is granted by this document or by any conduct of Vishay. Product names and markings noted herein may be trademarks of their respective owners.

Material Category Policy

Vishay Intertechnology, Inc. hereby certifies that all its products that are identified as RoHS-Compliant fulfill the definitions and restrictions defined under Directive 2011/65/EU of The European Parliament and of the Council of June 8, 2011 on the restriction of the use of certain hazardous substances in electrical and electronic equipment (EEE) - recast, unless otherwise specified as non-compliant.

Please note that some Vishay documentation may still make reference to RoHS Directive 2002/95/EC. We confirm that all the products identified as being compliant to Directive 2002/95/EC conform to Directive 2011/65/EU.

Vishay Intertechnology, Inc. hereby certifies that all its products that are identified as Halogen-Free follow Halogen-Free requirements as per JEDEC JS709A standards. Please note that some Vishay documentation may still make reference to the IEC 61249-2-21 definition. We confirm that all the products identified as being compliant to IEC 61249-2-21 conform to JEDEC JS709A standards.



**Стандарт
Электрон
Связь**

Мы молодая и активно развивающаяся компания в области поставок электронных компонентов. Мы поставляем электронные компоненты отечественного и импортного производства напрямую от производителей и с крупнейших складов мира.

Благодаря сотрудничеству с мировыми поставщиками мы осуществляем комплексные и плановые поставки широчайшего спектра электронных компонентов.

Собственная эффективная логистика и склад в обеспечивает надежную поставку продукции в точно указанные сроки по всей России.

Мы осуществляем техническую поддержку нашим клиентам и предпродажную проверку качества продукции. На все поставляемые продукты мы предоставляем гарантию .

Осуществляем поставки продукции под контролем ВП МО РФ на предприятия военно-промышленного комплекса России , а также работаем в рамках 275 ФЗ с открытием отдельных счетов в уполномоченном банке. Система менеджмента качества компании соответствует требованиям ГОСТ ISO 9001.

Минимальные сроки поставки, гибкие цены, неограниченный ассортимент и индивидуальный подход к клиентам являются основой для выстраивания долгосрочного и эффективного сотрудничества с предприятиями радиоэлектронной промышленности, предприятиями ВПК и научно-исследовательскими институтами России.

С нами вы становитесь еще успешнее!

Наши контакты:

Телефон: +7 812 627 14 35

Электронная почта: sales@st-electron.ru

Адрес: 198099, Санкт-Петербург,
Промышленная ул, дом № 19, литера Н,
помещение 100-Н Офис 331