



# Kinetis K64F Sub-Family Data Sheet

## 120 MHz ARM® Cortex®-M4-based Microcontroller with FPU

The K64 product family members are optimized for cost-sensitive applications requiring low-power, USB/Ethernet connectivity, and up to 256 KB of embedded SRAM. These devices share the comprehensive enablement and scalability of the Kinetis family.

This product offers:

- Run power consumption down to 250  $\mu$ A/MHz. Static power consumption down to 5.8  $\mu$ A with full state retention and 5  $\mu$ s wakeup. Lowest Static mode down to 339 nA
- USB LS/FS OTG 2.0 with embedded 3.3 V, 120 mA LDO Vreg, with USB device crystal-less operation
- 10/100 Mbit/s Ethernet MAC with MII and RMII interfaces

MK64FN1M0Vxx12  
MK64FX512Vxx12



121 XFBGA  
8 x 8 x 0.5 mm Pitch  
0.65 mm

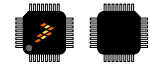

144 LQFP  
20 x 20 x 1.6 mm Pitch  
0.5 mm



144 MAPBGA  
13 x 13 x 1.46 mm  
Pitch 1 mm



100 QFP  
14 x 14 x 1.7 mm Pitch  
0.5 mm

### Performance

- Up to 120 MHz ARM® Cortex®-M4 core with DSP instructions and floating point unit

### Memories and memory interfaces

- Up to 1 MB program flash memory and 256 KB RAM
- Upto 128 KB FlexNVM and 4 KB FlexRAM on devices with FlexMemory
- FlexBus external bus interface

### System peripherals

- Multiple low-power modes, low-leakage wake-up unit
- Memory protection unit with multi-master protection
- 16-channel DMA controller
- External watchdog monitor and software watchdog

### Security and integrity modules

- Hardware CRC module
- Hardware random-number generator
- Hardware encryption supporting DES, 3DES, AES, MD5, SHA-1, and SHA-256 algorithms
- 128-bit unique identification (ID) number per chip

### Analog modules

- Two 16-bit SAR ADCs
- Two 12-bit DACs
- Three analog comparators (CMP)
- Voltage reference

### Communication interfaces

- Ethernet controller with MII and RMII interface
- USB full-/low-speed On-the-Go controller
- Controller Area Network (CAN) module
- Three SPI modules
- Three I2C modules. Support for up to 1 Mbit/s
- Six UART modules
- Secure Digital Host Controller (SDHC)
- I2S module

### Timers

- Two 8-channel Flex-Timers (PWM/Motor control)
- Two 2-channel FlexTimers (PWM/Quad decoder)
- IEEE 1588 timers
- 32-bit PITs and 16-bit low-power timers
- Real-time clock
- Programmable delay block

### Clocks

- 3 to 32 MHz and 32 kHz crystal oscillator
- PLL, FLL, and multiple internal oscillators
- 48 MHz Internal Reference Clock (IRC48M)

### Operating Characteristics

- Voltage range: 1.71 to 3.6 V
- Flash write voltage range: 1.71 to 3.6 V
- Temperature range (ambient): -40 to 105°C



### Ordering Information<sup>1</sup>

Part Number	Memory		Maximum number of I/O's
	Flash	SRAM (KB)	
MK64FX512VLL12	512 KB	256	66
MK64FN1M0VLL12	1 MB	256	66
MK64FX512VDC12	512 KB	256	83
MK64FN1M0VDC12	1 MB	256	83
MK64FX512VLQ12	512 KB	256	100
MK64FN1M0VLQ12	1 MB	256	100
MK64FX512VMD12	512 KB	256	100
MK64FN1M0VMD12	1 MB	256	100

1. To confirm current availability of orderable part numbers, go to <http://www.nxp.com> and perform a part number search.

### Related Resources

Type	Description	Resource
Selector Guide	The NXP Solution Advisor is a web-based tool that features interactive application wizards and a dynamic product selector.	<a href="#">Solution Advisor</a>
Product Brief	The Product Brief contains concise overview/summary information to enable quick evaluation of a device for design suitability.	K60PB <sup>1</sup>
Reference Manual	The Reference Manual contains a comprehensive description of the structure and function (operation) of a device.	K64P144M120SF5RM <sup>1</sup>
Data Sheet	The Data Sheet includes electrical characteristics and signal connections.	K64P144M120SF5 <sup>1</sup>
Package drawing	Package dimensions are provided in package drawings.	<ul style="list-style-type: none"> <li>• MAPBGA 144-pin: 98ASA00222D<sup>1</sup></li> <li>• LQFP 144-pin: 98ASS23177W<sup>1</sup></li> <li>• LQFP 100-pin: 98ASS23308W<sup>1</sup></li> <li>• XFBGA 121-pin: 98ASA00595D<sup>1</sup></li> </ul>

1. To find the associated resource, go to <http://www.nxp.com> and perform a search using this term.

## Kinetis K64 Family

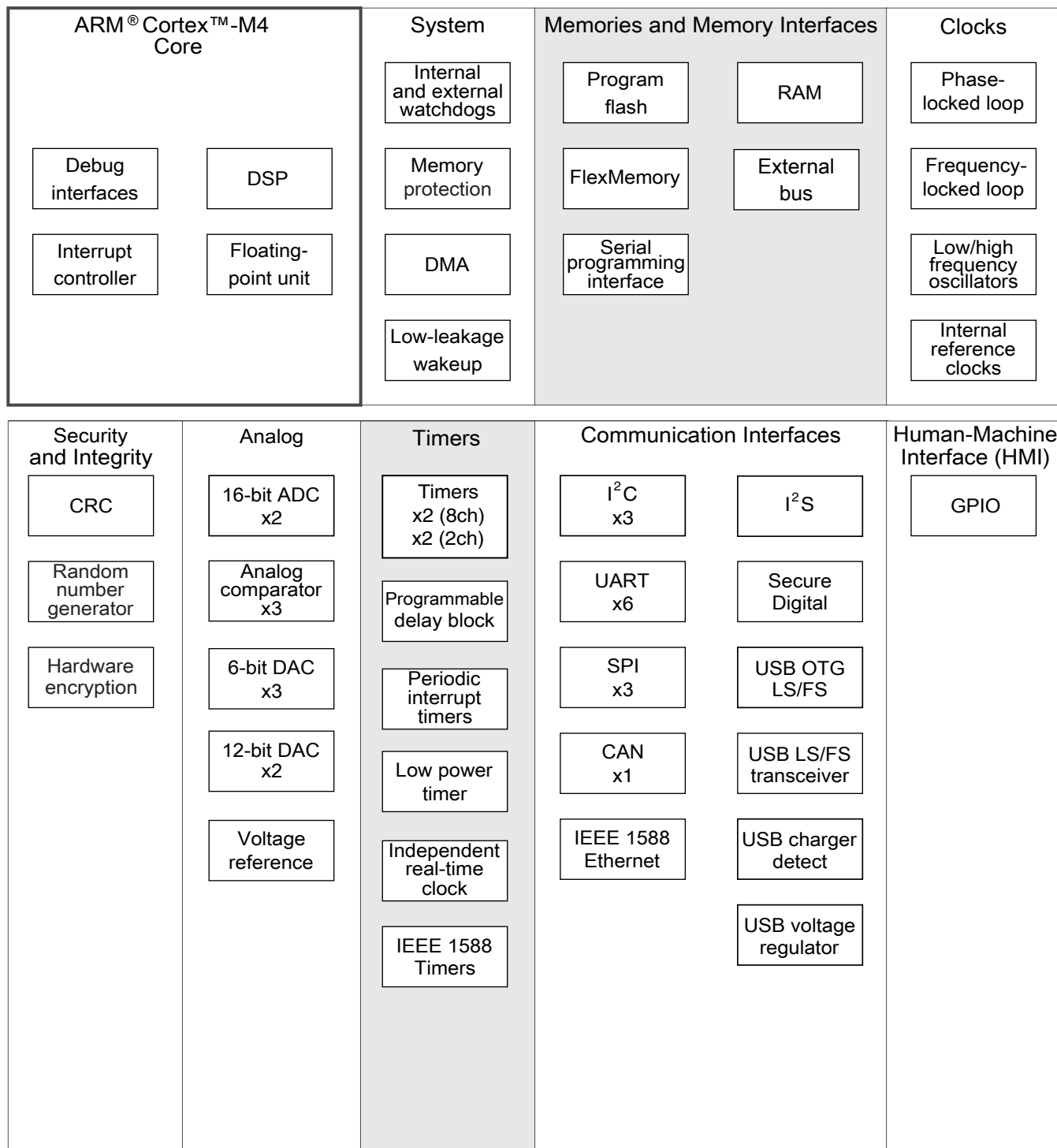

**Figure 1. K64 block diagram**

# Table of Contents

1	Ratings.....	5	3.6.2	CMP and 6-bit DAC electrical specifications.....	44
1.1	Thermal handling ratings.....	5	3.6.3	12-bit DAC electrical characteristics.....	46
1.2	Moisture handling ratings.....	5	3.6.4	Voltage reference electrical specifications.....	49
1.3	ESD handling ratings.....	5	3.7	Timers.....	50
1.4	Voltage and current operating ratings.....	5	3.8	Communication interfaces.....	50
2	General.....	6	3.8.1	Ethernet switching specifications.....	51
2.1	AC electrical characteristics.....	6	3.8.2	USB electrical specifications.....	53
2.2	Nonswitching electrical specifications.....	6	3.8.3	USB DCD electrical specifications.....	53
2.2.1	Voltage and current operating requirements.....	6	3.8.4	USB VREG electrical specifications.....	54
2.2.2	LVD and POR operating requirements.....	8	3.8.5	CAN switching specifications.....	54
2.2.3	Voltage and current operating behaviors.....	8	3.8.6	DSPI switching specifications (limited voltage range).....	55
2.2.4	Power mode transition operating behaviors.....	10	3.8.7	DSPI switching specifications (full voltage range).....	56
2.2.5	Power consumption operating behaviors.....	11	3.8.8	Inter-Integrated Circuit Interface (I2C) timing.....	58
2.2.6	EMC radiated emissions operating behaviors.....	16	3.8.9	UART switching specifications.....	60
2.2.7	Designing with radiated emissions in mind.....	17	3.8.10	SDHC specifications.....	60
2.2.8	Capacitance attributes.....	17	3.8.11	I2S switching specifications.....	61
2.3	Switching specifications.....	17	4	Dimensions.....	67
2.3.1	Device clock specifications.....	17	4.1	Obtaining package dimensions.....	67
2.3.2	General switching specifications.....	18	5	Pinout.....	67
2.4	Thermal specifications.....	19	5.1	K64 Signal Multiplexing and Pin Assignments.....	67
2.4.1	Thermal operating requirements.....	19	5.2	Unused analog interfaces.....	74
2.4.2	Thermal attributes.....	20	5.3	K64 Pinouts.....	75
3	Peripheral operating requirements and behaviors.....	21	6	Ordering parts.....	79
3.1	Core modules.....	21	6.1	Determining valid orderable parts.....	79
3.1.1	Debug trace timing specifications.....	21	7	Part identification.....	80
3.1.2	JTAG electricals.....	22	7.1	Description.....	80
3.2	System modules.....	25	7.2	Format.....	80
3.3	Clock modules.....	25	7.3	Fields.....	80
3.3.1	MCG specifications.....	25	7.4	Example.....	81
3.3.2	IRC48M specifications.....	27	8	Terminology and guidelines.....	81
3.3.3	Oscillator electrical specifications.....	28	8.1	Definitions.....	81
3.3.4	32 kHz oscillator electrical characteristics.....	30	8.2	Examples.....	82
3.4	Memories and memory interfaces.....	31	8.3	Typical-value conditions.....	82
3.4.1	Flash (FTFE) electrical specifications.....	31	8.4	Relationship between ratings and operating requirements.....	83
3.4.2	EzPort switching specifications.....	36	8.5	Guidelines for ratings and operating requirements.....	83
3.4.3	Flexbus switching specifications.....	36	9	Revision History.....	84
3.5	Security and integrity modules.....	39			
3.6	Analog.....	39			
3.6.1	ADC electrical specifications.....	40			

# 1 Ratings

## 1.1 Thermal handling ratings

Symbol	Description	Min.	Max.	Unit	Notes
T <sub>STG</sub>	Storage temperature	-55	150	°C	1
T <sub>SDR</sub>	Solder temperature, lead-free	—	260	°C	2
	Solder temperature, leaded	—	245		

1. Determined according to JEDEC Standard JESD22-A103, *High Temperature Storage Life*.
2. Determined according to IPC/JEDEC Standard J-STD-020, *Moisture/Reflow Sensitivity Classification for Nonhermetic Solid State Surface Mount Devices*.

## 1.2 Moisture handling ratings

Symbol	Description	Min.	Max.	Unit	Notes
MSL	Moisture sensitivity level	—	3	—	1

1. Determined according to IPC/JEDEC Standard J-STD-020, *Moisture/Reflow Sensitivity Classification for Nonhermetic Solid State Surface Mount Devices*.

## 1.3 ESD handling ratings

Symbol	Description	Min.	Max.	Unit	Notes
V <sub>HBM</sub>	Electrostatic discharge voltage, human body model	-2000	+2000	V	1
V <sub>CDM</sub>	Electrostatic discharge voltage, charged-device model	-500	+500	V	2
I <sub>LAT</sub>	Latch-up current at ambient temperature of 105°C	-100	+100	mA	3

1. Determined according to JEDEC Standard JESD22-A114, *Electrostatic Discharge (ESD) Sensitivity Testing Human Body Model (HBM)*.
2. Determined according to JEDEC Standard JESD22-C101, *Field-Induced Charged-Device Model Test Method for Electrostatic-Discharge-Withstand Thresholds of Microelectronic Components*.
3. Determined according to JEDEC Standard JESD78, *IC Latch-Up Test*.

## 1.4 Voltage and current operating ratings

## General

Symbol	Description	Min.	Max.	Unit
$V_{DD}$	Digital supply voltage	-0.3	3.8	V
$I_{DD}$	Digital supply current	—	185	mA
$V_{DIO}$	Digital input voltage (except RESET, EXTAL, and XTAL)	-0.3	5.5	V
$V_{DRTC\_WAKEUP}$	RTC Wakeup input voltage	-0.3	$V_{BAT} + 0.3$	V
$V_{AIO}$	Analog <sup>1</sup> , RESET, EXTAL, and XTAL input voltage	-0.3	$V_{DD} + 0.3$	V
$I_D$	Maximum current single pin limit (applies to all digital pins)	-25	25	mA
$V_{DDA}$	Analog supply voltage	$V_{DD} - 0.3$	$V_{DD} + 0.3$	V
$V_{USB0\_DP}$	USB0_DP input voltage	-0.3	3.63	V
$V_{USB0\_DM}$	USB0_DM input voltage	-0.3	3.63	V
$V_{REGIN}$	USB regulator input	-0.3	6.0	V
$V_{BAT}$	RTC battery supply voltage	-0.3	3.8	V

1. Analog pins are defined as pins that do not have an associated general purpose I/O port function.

## 2 General

### 2.1 AC electrical characteristics

Unless otherwise specified, propagation delays are measured from the 50% to the 50% point, and rise and fall times are measured at the 20% and 80% points, as shown in the following figure.

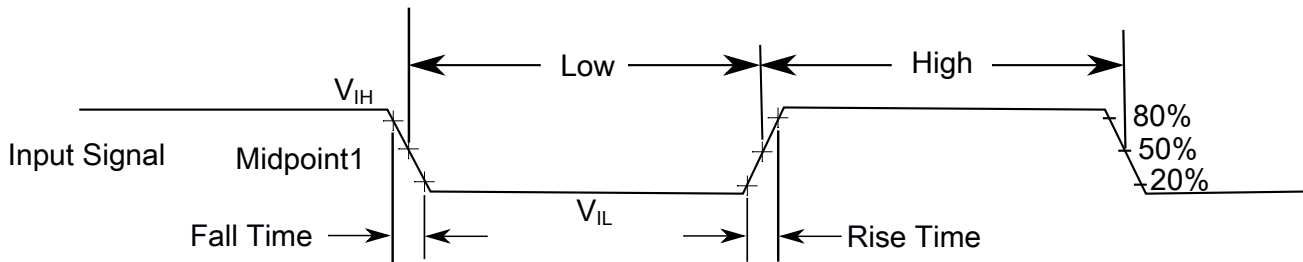

The midpoint is  $V_{IL} + (V_{IH} - V_{IL}) / 2$

**Figure 2. Input signal measurement reference**

### 2.2 Nonswitching electrical specifications

## 2.2.1 Voltage and current operating requirements

**Table 1. Voltage and current operating requirements**

Symbol	Description	Min.	Max.	Unit	Notes
V <sub>DD</sub>	Supply voltage	1.71	3.6	V	
V <sub>DDA</sub>	Analog supply voltage	1.71	3.6	V	
V <sub>DD</sub> – V <sub>DDA</sub>	V <sub>DD</sub> -to-V <sub>DDA</sub> differential voltage	-0.1	0.1	V	
V <sub>SS</sub> – V <sub>SSA</sub>	V <sub>SS</sub> -to-V <sub>SSA</sub> differential voltage	-0.1	0.1	V	
V <sub>BAT</sub>	RTC battery supply voltage	1.71	3.6	V	
V <sub>IH</sub>	Input high voltage <ul style="list-style-type: none"> <li>• 2.7 V ≤ V<sub>DD</sub> ≤ 3.6 V</li> <li>• 1.7 V ≤ V<sub>DD</sub> ≤ 2.7 V</li> </ul>	0.7 × V <sub>DD</sub> 0.75 × V <sub>DD</sub>	— —	V V	
V <sub>IL</sub>	Input low voltage <ul style="list-style-type: none"> <li>• 2.7 V ≤ V<sub>DD</sub> ≤ 3.6 V</li> <li>• 1.7 V ≤ V<sub>DD</sub> ≤ 2.7 V</li> </ul>	— —	0.35 × V <sub>DD</sub> 0.3 × V <sub>DD</sub>	V V	
V <sub>HYS</sub>	Input hysteresis	0.06 × V <sub>DD</sub>	—	V	
I <sub>CDIO</sub>	Digital pin negative DC injection current — single pin <ul style="list-style-type: none"> <li>• V<sub>IN</sub> &lt; V<sub>SS</sub>-0.3V</li> </ul>	-5	—	mA	1
I <sub>CAIO</sub>	Analog <sup>2</sup> , EXTAL, and XTAL pin DC injection current — single pin <ul style="list-style-type: none"> <li>• V<sub>IN</sub> &lt; V<sub>SS</sub>-0.3V (Negative current injection)</li> <li>• V<sub>IN</sub> &gt; V<sub>DD</sub>+0.3V (Positive current injection)</li> </ul>	-5 —	— +5	mA	3
I <sub>Ccont</sub>	Contiguous pin DC injection current — regional limit, includes sum of negative injection currents or sum of positive injection currents of 16 contiguous pins <ul style="list-style-type: none"> <li>• Negative current injection</li> <li>• Positive current injection</li> </ul>	-25 —	— +25	mA	
V <sub>ODPU</sub>	Open drain pullup voltage level	V <sub>DD</sub>	V <sub>DD</sub>	V	4
V <sub>RAM</sub>	V <sub>DD</sub> voltage required to retain RAM	1.2	—	V	
V <sub>RFVBAT</sub>	V <sub>BAT</sub> voltage required to retain the VBAT register file	V <sub>POR_VBAT</sub>	—	V	

- All 5 V tolerant digital I/O pins are internally clamped to V<sub>SS</sub> through an ESD protection diode. There is no diode connection to V<sub>DD</sub>. If V<sub>IN</sub> is less than V<sub>DIO\_MIN</sub>, a current limiting resistor is required. If V<sub>IN</sub> greater than V<sub>DIO\_MIN</sub> (=V<sub>SS</sub>-0.3V) is observed, then there is no need to provide current limiting resistors at the pads. The negative DC injection current limiting resistor is calculated as  $R=(V_{DIO\_MIN}-V_{IN})/|I_{CDIO}|$ .
- Analog pins are defined as pins that do not have an associated general purpose I/O port function. Additionally, EXTAL and XTAL are analog pins.
- All analog pins are internally clamped to V<sub>SS</sub> and V<sub>DD</sub> through ESD protection diodes. If V<sub>IN</sub> is less than V<sub>AIO\_MIN</sub> or greater than V<sub>AIO\_MAX</sub>, a current limiting resistor is required. The negative DC injection current limiting resistor is calculated as  $R=(V_{AIO\_MIN}-V_{IN})/|I_{CAIO}|$ . The positive injection current limiting resistor is calculated as  $R=(V_{IN}-V_{AIO\_MAX})/|I_{CAIO}|$ . Select the larger of these two calculated resistances if the pin is exposed to positive and negative injection currents.
- Open drain outputs must be pulled to V<sub>DD</sub>.

## 2.2.2 LVD and POR operating requirements

Table 2.  $V_{DD}$  supply LVD and POR operating requirements

Symbol	Description	Min.	Typ.	Max.	Unit	Notes
$V_{POR}$	Falling VDD POR detect voltage	0.8	1.1	1.5	V	
$V_{LVDH}$	Falling low-voltage detect threshold — high range (LVDV=01)	2.48	2.56	2.64	V	
$V_{LVW1H}$	Low-voltage warning thresholds — high range					1
	• Level 1 falling (LVWV=00)	2.62	2.70	2.78	V	
$V_{LVW2H}$	• Level 2 falling (LVWV=01)	2.72	2.80	2.88	V	
$V_{LVW3H}$	• Level 3 falling (LVWV=10)	2.82	2.90	2.98	V	
$V_{LVW4H}$	• Level 4 falling (LVWV=11)	2.92	3.00	3.08	V	
$V_{HYSH}$	Low-voltage inhibit reset/recover hysteresis — high range	—	80	—	mV	
$V_{LVDL}$	Falling low-voltage detect threshold — low range (LVDV=00)	1.54	1.60	1.66	V	
$V_{LVW1L}$	Low-voltage warning thresholds — low range					1
	• Level 1 falling (LVWV=00)	1.74	1.80	1.86	V	
$V_{LVW2L}$	• Level 2 falling (LVWV=01)	1.84	1.90	1.96	V	
$V_{LVW3L}$	• Level 3 falling (LVWV=10)	1.94	2.00	2.06	V	
$V_{LVW4L}$	• Level 4 falling (LVWV=11)	2.04	2.10	2.16	V	
$V_{HYSL}$	Low-voltage inhibit reset/recover hysteresis — low range	—	60	—	mV	
$V_{BG}$	Bandgap voltage reference	0.97	1.00	1.03	V	
$t_{LPO}$	Internal low power oscillator period — factory trimmed	900	1000	1100	$\mu$ s	

1. Rising threshold is the sum of falling threshold and hysteresis voltage

Table 3. VBAT power operating requirements

Symbol	Description	Min.	Typ.	Max.	Unit	Notes
$V_{POR\_VBAT}$	Falling VBAT supply POR detect voltage	0.8	1.1	1.5	V	

## 2.2.3 Voltage and current operating behaviors

Table 4. Voltage and current operating behaviors

Symbol	Description	Min.	Max.	Unit	Notes
$V_{OH}$	Output high voltage — high drive strength				

Table continues on the next page...



**Table 4. Voltage and current operating behaviors (continued)**

Symbol	Description	Min.	Max.	Unit	Notes
	<ul style="list-style-type: none"> <li>• <math>2.7\text{ V} \leq V_{DD} \leq 3.6\text{ V}</math>, <math>I_{OH} = -8\text{ mA}</math></li> <li>• <math>1.71\text{ V} \leq V_{DD} \leq 2.7\text{ V}</math>, <math>I_{OH} = -3\text{ mA}</math></li> </ul>	$V_{DD} - 0.5$	—	V	
	Output high voltage — low drive strength <ul style="list-style-type: none"> <li>• <math>2.7\text{ V} \leq V_{DD} \leq 3.6\text{ V}</math>, <math>I_{OH} = -2\text{ mA}</math></li> <li>• <math>1.71\text{ V} \leq V_{DD} \leq 2.7\text{ V}</math>, <math>I_{OH} = -0.6\text{ mA}</math></li> </ul>	$V_{DD} - 0.5$	—	V	
$I_{OHT}$	Output high current total for all ports	—	100	mA	
$V_{OH\_RTC\_WAKEUP}$	Output high voltage — high drive strength <ul style="list-style-type: none"> <li>• <math>2.7\text{ V} \leq V_{BAT} \leq 3.6\text{ V}</math>, <math>I_{OH} = -10\text{ mA}</math></li> <li>• <math>1.71\text{ V} \leq V_{BAT} \leq 2.7\text{ V}</math>, <math>I_{OH} = -3\text{ mA}</math></li> </ul>	$V_{BAT} - 0.5$	—	V	
	Output high voltage — low drive strength <ul style="list-style-type: none"> <li>• <math>2.7\text{ V} \leq V_{BAT} \leq 3.6\text{ V}</math>, <math>I_{OH} = -2\text{ mA}</math></li> <li>• <math>1.71\text{ V} \leq V_{BAT} \leq 2.7\text{ V}</math>, <math>I_{OH} = -0.6\text{ mA}</math></li> </ul>	$V_{BAT} - 0.5$	—	V	
$I_{OH\_RTC\_WAKEUP}$	Output high current total for RTC_WAKEUP pins	—	100	mA	
$V_{OL}$	Output low voltage — high drive strength <ul style="list-style-type: none"> <li>• <math>2.7\text{ V} \leq V_{DD} \leq 3.6\text{ V}</math>, <math>I_{OL} = 9\text{ mA}</math></li> <li>• <math>1.71\text{ V} \leq V_{DD} \leq 2.7\text{ V}</math>, <math>I_{OL} = 3\text{ mA}</math></li> </ul>	—	0.5	V	
	Output low voltage — low drive strength <ul style="list-style-type: none"> <li>• <math>2.7\text{ V} \leq V_{DD} \leq 3.6\text{ V}</math>, <math>I_{OL} = 2\text{ mA}</math></li> <li>• <math>1.71\text{ V} \leq V_{DD} \leq 2.7\text{ V}</math>, <math>I_{OL} = 0.6\text{ mA}</math></li> </ul>	—	0.5	V	
$I_{OLT}$	Output low current total for all ports	—	100	mA	
$V_{OL\_RTC\_WAKEUP}$	Output low voltage — high drive strength <ul style="list-style-type: none"> <li>• <math>2.7\text{ V} \leq V_{BAT} \leq 3.6\text{ V}</math>, <math>I_{OL} = 10\text{ mA}</math></li> <li>• <math>1.71\text{ V} \leq V_{BAT} \leq 2.7\text{ V}</math>, <math>I_{OL} = 3\text{ mA}</math></li> </ul>	—	0.5	V	
	Output low voltage — low drive strength <ul style="list-style-type: none"> <li>• <math>2.7\text{ V} \leq V_{BAT} \leq 3.6\text{ V}</math>, <math>I_{OL} = 2\text{ mA}</math></li> <li>• <math>1.71\text{ V} \leq V_{BAT} \leq 2.7\text{ V}</math>, <math>I_{OL} = 0.6\text{ mA}</math></li> </ul>	—	0.5	V	
$I_{OL\_RTC\_WAKEUP}$	Output low current total for RTC_WAKEUP pins	—	100	mA	
$I_{IN}$	Input leakage current (per pin) for full temperature range	—	1	$\mu\text{A}$	1
$I_{IN}$	Input leakage current (per pin) at 25°C	—	0.025	$\mu\text{A}$	1
$I_{IN\_RTC\_WAKEUP}$	Input leakage current (per RTC_WAKEUP pin) for full temperature range	—	1	$\mu\text{A}$	
$I_{IN\_RTC\_WAKEUP}$	Input leakage current (per RTC_WAKEUP pin) at 25°C	—	0.025	$\mu\text{A}$	

Table continues on the next page...

**Table 4. Voltage and current operating behaviors (continued)**

Symbol	Description	Min.	Max.	Unit	Notes
I <sub>OZ</sub>	Hi-Z (off-state) leakage current (per pin)	—	0.25	μA	
I <sub>OZ_RTC_WAKEUP</sub>	Hi-Z (off-state) leakage current (per RTC_WAKEUP pin)	—	0.25	μA	
R <sub>PU</sub>	Internal pullup resistors (except RTC_WAKEUP pins)	20	50	kΩ	2
R <sub>PD</sub>	Internal pulldown resistors (except RTC_WAKEUP pins)	20	50	kΩ	3

1. Measured at V<sub>DD</sub>=3.6V
2. Measured at V<sub>DD</sub> supply voltage = V<sub>DD</sub> min and V<sub>input</sub> = V<sub>SS</sub>
3. Measured at V<sub>DD</sub> supply voltage = V<sub>DD</sub> min and V<sub>input</sub> = V<sub>DD</sub>

## 2.2.4 Power mode transition operating behaviors

All specifications except t<sub>POR</sub>, and VLLS<sub>x</sub>→RUN recovery times in the following table assume this clock configuration:

- CPU and system clocks = 100 MHz
- Bus clock = 50 MHz
- FlexBus clock = 50 MHz
- Flash clock = 25 MHz

**Table 5. Power mode transition operating behaviors**

Symbol	Description	Min.	Max.	Unit	Notes
t <sub>POR</sub>	After a POR event, amount of time from the point V <sub>DD</sub> reaches 1.71 V to execution of the first instruction across the operating temperature range of the chip.	—	300	μs	
	• VLLS0 → RUN	—	156	μs	
	• VLLS1 → RUN	—	156	μs	
	• VLLS2 → RUN	—	78	μs	
	• VLLS3 → RUN	—	78	μs	
	• LLS → RUN	—	4.8	μs	
	• VLPS → RUN	—	4.5	μs	
	• STOP → RUN	—	4.5	μs	

## 2.2.5 Power consumption operating behaviors

### NOTE

The maximum values represent characterized results equivalent to the mean plus three times the standard deviation (mean + 3 sigma).

**Table 6. Power consumption operating behaviors**

Symbol	Description	Min.	Typ.	Max.	Unit	Notes
I <sub>DDA</sub>	Analog supply current	—	—	See note	mA	1
I <sub>DD_RUN</sub>	Run mode current — all peripheral clocks disabled, code executing from flash	—	31.1	36.65	mA	2
		—	31	36.75	mA	
I <sub>DD_RUN</sub>	Run mode current — all peripheral clocks enabled, code executing from flash	—	42.7	48.35	mA	3, 4
		—	40	41.60	mA	
		—	48.33	51.50	mA	
I <sub>DD_WAIT</sub>	Wait mode high frequency current at 3.0 V — all peripheral clocks disabled	—	17.9	—	mA	2
I <sub>DD_WAIT</sub>	Wait mode reduced frequency current at 3.0 V — all peripheral clocks disabled	—	6.9	—	mA	5
I <sub>DD_VLPR</sub>	Very-low-power run mode current at 3.0 V — all peripheral clocks disabled	—	1.0	—	mA	6
I <sub>DD_VLPR</sub>	Very-low-power run mode current at 3.0 V — all peripheral clocks enabled	—	1.7	—	mA	7
I <sub>DD_VLPW</sub>	Very-low-power wait mode current at 3.0 V — all peripheral clocks disabled	—	0.678	—	mA	8
I <sub>DD_STOP</sub>	Stop mode current at 3.0 V	—	0.49	1.24	mA	
		—	1.18	4.3	mA	
		—	3.0	12.5	mA	
I <sub>DD_VLPS</sub>	Very-low-power stop mode current at 3.0 V	—	57	139.31	μA	
		—	291	679.33	μA	
		—	927.3	1869.85	μA	
I <sub>DD_LLS</sub>	Low leakage stop mode current at 3.0 V					9

Table continues on the next page...

**Table 6. Power consumption operating behaviors (continued)**

Symbol	Description	Min.	Typ.	Max.	Unit	Notes
	<ul style="list-style-type: none"> <li>• @ -40 to 25°C</li> <li>• @ 70°C</li> <li>• @ 105°C</li> </ul>	—	5.8	10.48	μA	
I <sub>DD_VLLS3</sub>	Very low-leakage stop mode 3 current at 3.0 V <ul style="list-style-type: none"> <li>• @ -40 to 25°C</li> <li>• @ 70°C</li> <li>• @ 105°C</li> </ul>	—	4.4	5.54	μA	
		—	21	36.46	μA	
		—	90.2	150.17	μA	
I <sub>DD_VLLS2</sub>	Very low-leakage stop mode 2 current at 3.0 V <ul style="list-style-type: none"> <li>• @ -40 to 25°C</li> <li>• @ 70°C</li> <li>• @ 105°C</li> </ul>	—	2.1	2.34	μA	
		—	6.84	10.36	μA	
		—	29.4	46.74	μA	
I <sub>DD_VLLS1</sub>	Very low-leakage stop mode 1 current at 3.0 V <ul style="list-style-type: none"> <li>• @ -40 to 25°C</li> <li>• @ 70°C</li> <li>• @ 105°C</li> </ul>	—	0.817	0.86	μA	
		—	3.97	5.77	μA	
		—	21.3	33.99	μA	
I <sub>DD_VLLS0</sub>	Very low-leakage stop mode 0 current at 3.0 V with POR detect circuit enabled <ul style="list-style-type: none"> <li>• @ -40 to 25°C</li> <li>• @ 70°C</li> <li>• @ 105°C</li> </ul>	—	0.52	0.62	μA	
		—	3.67	5.7	μA	
		—	21.20	34.9	μA	
I <sub>DD_VLLS0</sub>	Very low-leakage stop mode 0 current at 3.0 V with POR detect circuit disabled <ul style="list-style-type: none"> <li>• @ -40 to 25°C</li> <li>• @ 70°C</li> <li>• @ 105°C</li> </ul>	—	0.339	0.412	μA	
		—	3.36	4.2	μA	
		—	20.3	29.9	μA	
I <sub>DD_VBAT</sub>	Average current with RTC and 32 kHz disabled <ul style="list-style-type: none"> <li>• @ 1.8 V <ul style="list-style-type: none"> <li>• @ -40 to 25°C</li> <li>• @ 70°C</li> <li>• @ 105°C</li> </ul> </li> <li>• @ 3.0 V <ul style="list-style-type: none"> <li>• @ -40 to 25°C</li> <li>• @ 70°C</li> <li>• @ 105°C</li> </ul> </li> </ul>	—	0.16	0.19	μA	
		—	0.55	0.72	μA	
		—	2.5	3.68	μA	
		—	0.18	0.21	μA	
		—	0.66	0.86	μA	
		—	2.92	4.30	μA	

Table continues on the next page...

**Table 6. Power consumption operating behaviors (continued)**

Symbol	Description	Min.	Typ.	Max.	Unit	Notes
I <sub>DD_VBAT</sub>	Average current when CPU is not accessing RTC registers					10
	• @ 1.8 V					
	• @ -40 to 25°C	—	0.59	0.70	μA	
	• @ 70°C	—	1.0	1.30	μA	
	• @ 105°C	—	3.0	4.42	μA	
	• @ 3.0 V					
	• @ -40 to 25°C	—	0.71	0.84	μA	
• @ 70°C	—	1.22	1.59	μA		
• @ 105°C	—	3.5	5.15	μA		

- The analog supply current is the sum of the active or disabled current for each of the analog modules on the device. See each module's specification for its supply current.
- 120 MHz core and system clock, 60 MHz bus, 30 MHz FlexBus clock, and 20 MHz flash clock. MCG configured for PEE mode. All peripheral clocks disabled.
- 120 MHz core and system clock, 60 MHz bus clock, 30 MHz Flexbus clock, and 20 MHz flash clock. MCG configured for PEE mode. All peripheral clocks enabled.
- Max values are measured with CPU executing DSP instructions.
- 25 MHz core and system clock, 25 MHz bus clock, and 25 MHz FlexBus and flash clock. MCG configured for FEI mode.
- 4 MHz core, system, FlexBus, and bus clock and 0.5 MHz flash clock. MCG configured for BLPE mode. All peripheral clocks disabled. Code executing from flash.
- 4 MHz core, system, FlexBus, and bus clock and 0.5 MHz flash clock. MCG configured for BLPE mode. All peripheral clocks enabled but peripherals are not in active operation. Code executing from flash.
- 4 MHz core, system, FlexBus, and bus clock and 0.5 MHz flash clock. MCG configured for BLPE mode. All peripheral clocks disabled.
- Data reflects devices with 256 KB of RAM.
- Includes 32kHz oscillator current and RTC operation.

**Table 7. Low power mode peripheral adders — typical value**

Symbol	Description	Temperature (°C)						Unit
		-40	25	50	70	85	105	
I <sub>IREFSTEN4MHZ</sub>	4 MHz internal reference clock (IRC) adder. Measured by entering STOP or VLPS mode with 4 MHz IRC enabled.	56	56	56	56	56	56	μA
I <sub>IREFSTEN32KHZ</sub>	32 kHz internal reference clock (IRC) adder. Measured by entering STOP mode with the 32 kHz IRC enabled.	52	52	52	52	52	52	μA
I <sub>EREFSTEN4MHZ</sub>	External 4 MHz crystal clock adder. Measured by entering STOP or VLPS mode with the crystal enabled.	206	228	237	245	251	258	uA
I <sub>EREFSTEN32KHZ</sub>	External 32 kHz crystal clock adder by means of the OSC0_CR[EREFSTEN and EREFSTEN] bits. Measured by							

Table continues on the next page...

**Table 7. Low power mode peripheral adders — typical value (continued)**

Symbol	Description	Temperature (°C)						Unit
		-40	25	50	70	85	105	
	entering all modes with the crystal enabled.	440	490	540	560	570	580	nA
	VLLS1	440	490	540	560	570	580	
	VLLS3	490	490	540	560	570	680	
	LLS	510	560	560	560	610	680	
	VLPS	510	560	560	560	610	680	
	STOP							
I <sub>48MIRC</sub>	48 Mhz internal reference clock	350	350	350	350	350	350	μA
I <sub>CMP</sub>	CMP peripheral adder measured by placing the device in VLLS1 mode with CMP enabled using the 6-bit DAC and a single external input for compare. Includes 6-bit DAC power consumption.	22	22	22	22	22	22	μA
I <sub>RTC</sub>	RTC peripheral adder measured by placing the device in VLLS1 mode with external 32 kHz crystal enabled by means of the RTC_CR[OSCE] bit and the RTC ALARM set for 1 minute. Includes ERCLK32K (32 kHz external crystal) power consumption.	432	357	388	475	532	810	nA
I <sub>UART</sub>	UART peripheral adder measured by placing the device in STOP or VLPS mode with selected clock source waiting for RX data at 115200 baud rate. Includes selected clock source power consumption.							
	MCGIRCLK (4 MHz internal reference clock)	66	66	66	66	66	66	μA
	OSCERCLK (4 MHz external crystal)	214	237	246	254	260	268	
I <sub>BG</sub>	Bandgap adder when BGEN bit is set and device is placed in VLPx, LLS, or VLLSx mode.	45	45	45	45	45	45	μA
I <sub>ADC</sub>	ADC peripheral adder combining the measured values at V <sub>DD</sub> and V <sub>DDA</sub> by placing the device in STOP or VLPS mode. ADC is configured for low power mode using the internal clock and continuous conversions.	42	42	42	42	42	42	μA

### 2.2.5.1 Diagram: Typical IDD\_RUN operating behavior

The following data was measured under these conditions:

- No GPIOs toggled
- Code execution from flash with cache enabled
- For the ALLOFF curve, all peripheral clocks are disabled except FTFE

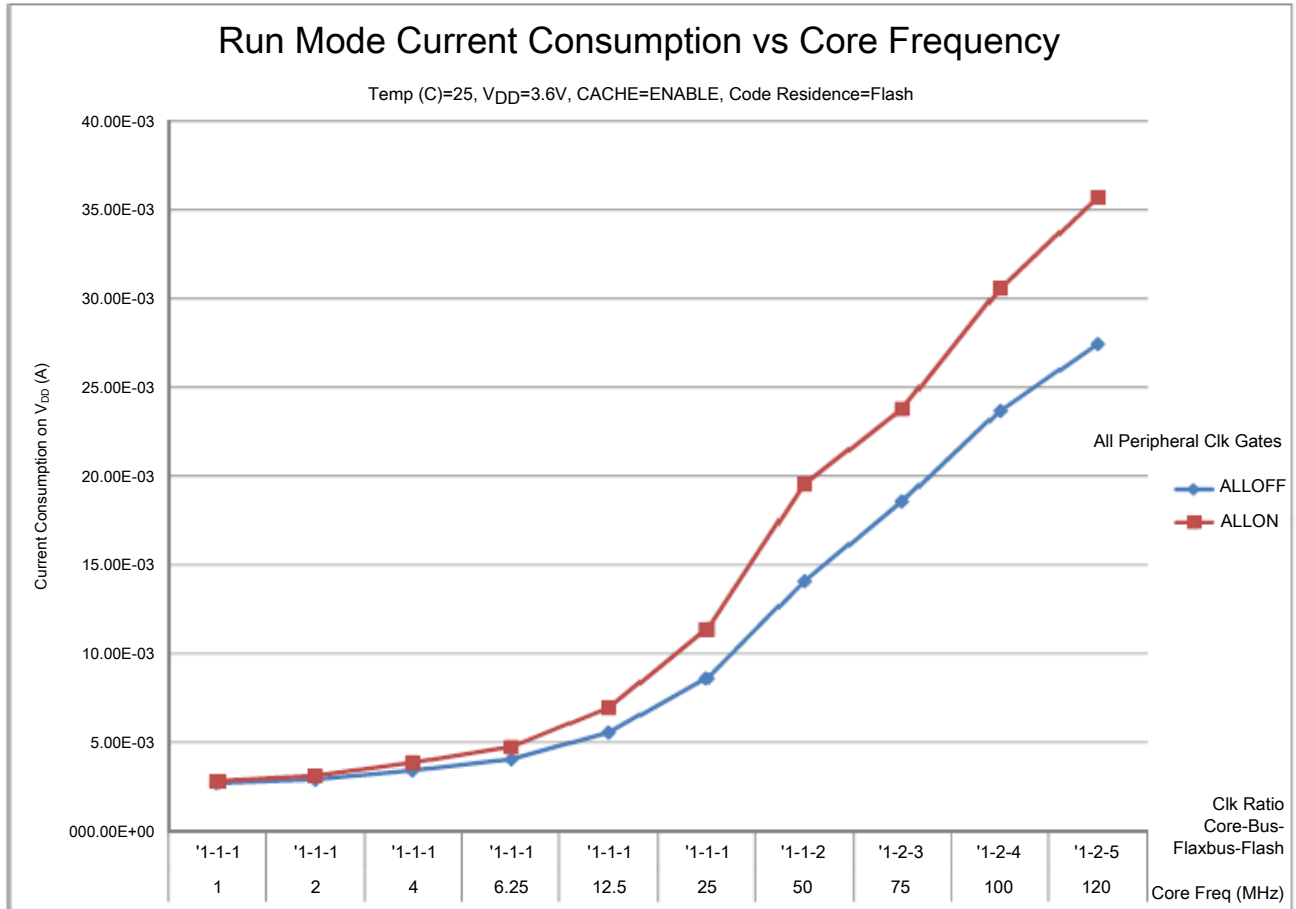

**Figure 3. Run mode supply current vs. core frequency**

General

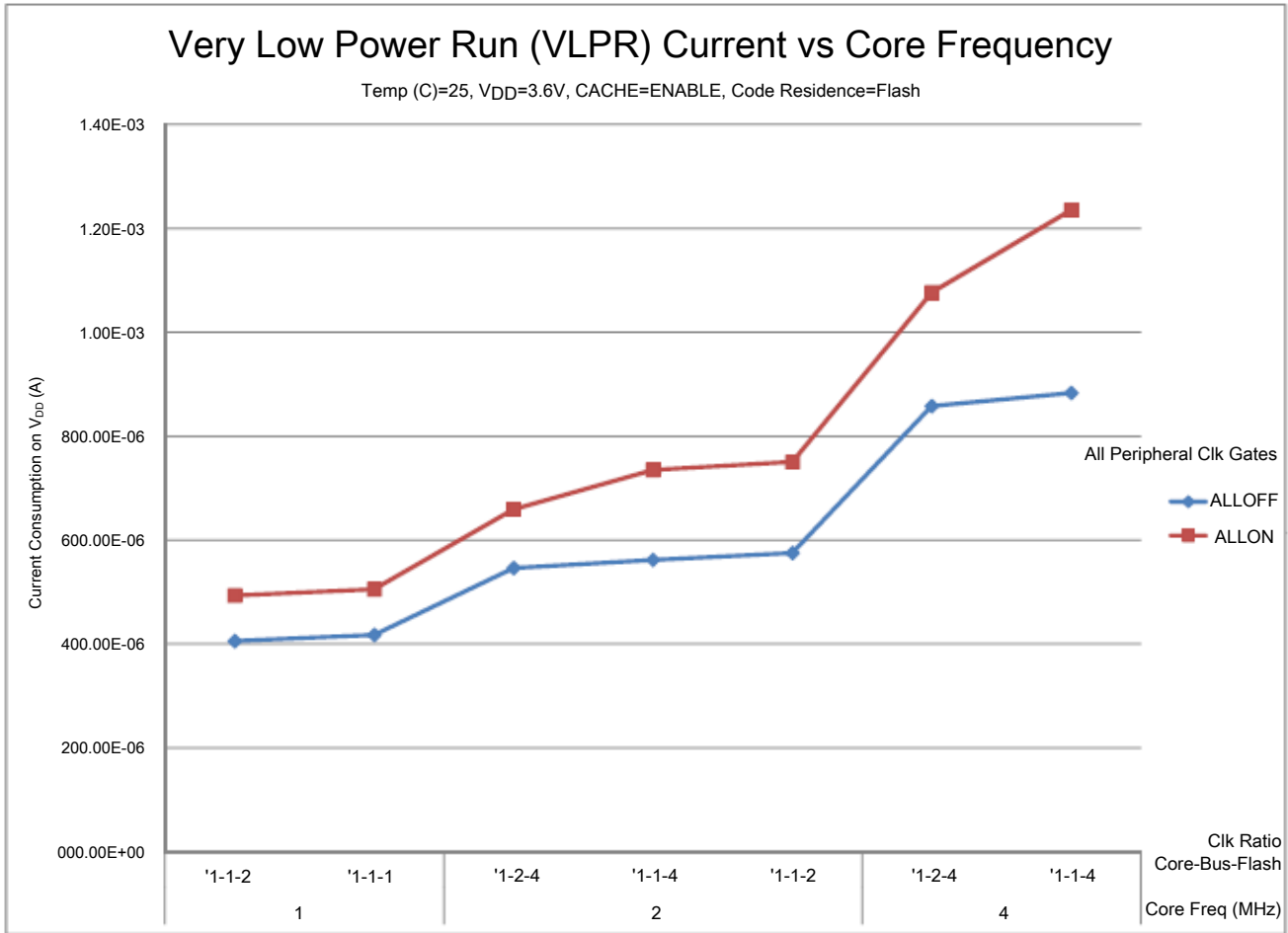

Figure 4. VLPR mode supply current vs. core frequency

## 2.2.6 EMC radiated emissions operating behaviors

Table 8. EMC radiated emissions operating behaviors

Symbol	Description	Frequency band (MHz)	Typ.	Unit	Notes
			144 LQFP		
V <sub>RE1</sub>	Radiated emissions voltage, band 1	0.15–50	16	dBμV	1, 2
V <sub>RE2</sub>	Radiated emissions voltage, band 2	50–150	22	dBμV	
V <sub>RE3</sub>	Radiated emissions voltage, band 3	150–500	21	dBμV	
V <sub>RE4</sub>	Radiated emissions voltage, band 4	500–1000	16	dBμV	
V <sub>RE_IEC</sub>	IEC level	0.15–1000	L	—	2, 3

1. Determined according to IEC Standard 61967-1, *Integrated Circuits - Measurement of Electromagnetic Emissions, 150 kHz to 1 GHz Part 1: General Conditions and Definitions* and IEC Standard 61967-2, *Integrated Circuits - Measurement of Electromagnetic Emissions, 150 kHz to 1 GHz Part 2: Measurement of Radiated Emissions—TEM Cell and*



*Wideband TEM Cell Method.* Measurements were made while the microcontroller was running basic application code. The reported emission level is the value of the maximum measured emission, rounded up to the next whole number, from among the measured orientations in each frequency range.

2.  $V_{DD} = 3.3\text{ V}$ ,  $T_A = 25\text{ °C}$ ,  $f_{OSC} = 12\text{ MHz}$  (crystal),  $f_{SYS} = 96\text{ MHz}$ ,  $f_{BUS} = 48\text{ MHz}$
3. Specified according to Annex D of IEC Standard 61967-2, *Measurement of Radiated Emissions—TEM Cell and Wideband TEM Cell Method*

## 2.2.7 Designing with radiated emissions in mind

To find application notes that provide guidance on designing your system to minimize interference from radiated emissions:

1. Go to [www.nxp.com](http://www.nxp.com).
2. Perform a keyword search for “EMC design.”

## 2.2.8 Capacitance attributes

Table 9. Capacitance attributes

Symbol	Description	Min.	Max.	Unit
$C_{IN\_A}$	Input capacitance: analog pins	—	7	pF
$C_{IN\_D}$	Input capacitance: digital pins	—	7	pF

## 2.3 Switching specifications

### 2.3.1 Device clock specifications

Table 10. Device clock specifications

Symbol	Description	Min.	Max.	Unit	Notes
Normal run mode					
$f_{SYS}$	System and core clock	—	120	MHz	
	System and core clock when Full Speed USB in operation	20	—	MHz	
$f_{ENET}$	System and core clock when ethernet in operation			MHz	
	• 10 Mbps	5	—		
	• 100 Mbps	50	—		
$f_{BUS}$	Bus clock	—	60	MHz	
FB_CLK	FlexBus clock	—	50	MHz	
$f_{FLASH}$	Flash clock	—	25	MHz	

Table continues on the next page...

**Table 10. Device clock specifications (continued)**

Symbol	Description	Min.	Max.	Unit	Notes
f <sub>LPTMR</sub>	LPTMR clock	—	25	MHz	
VLPR mode <sup>1</sup>					
f <sub>SYS</sub>	System and core clock	—	4	MHz	
f <sub>BUS</sub>	Bus clock	—	4	MHz	
FB_CLK	FlexBus clock	—	4	MHz	
f <sub>FLASH</sub>	Flash clock	—	0.8	MHz	
f <sub>ERCLK</sub>	External reference clock	—	16	MHz	
f <sub>LPTMR_pin</sub>	LPTMR clock	—	25	MHz	
f <sub>LPTMR_ERCLK</sub>	LPTMR external reference clock	—	16	MHz	
f <sub>FlexCAN_ERCLK</sub>	FlexCAN external reference clock	—	8	MHz	
f <sub>I2S_MCLK</sub>	I2S master clock	—	12.5	MHz	
f <sub>I2S_BCLK</sub>	I2S bit clock	—	4	MHz	

1. The frequency limitations in VLPR mode here override any frequency specification listed in the timing specification for any other module.

## 2.3.2 General switching specifications

These general purpose specifications apply to all signals configured for GPIO, UART, CAN, CMT, IEEE 1588 timer, timers, and I<sup>2</sup>C signals.

**Table 11. General switching specifications**

Symbol	Description	Min.	Max.	Unit	Notes
	GPIO pin interrupt pulse width (digital glitch filter disabled) — Synchronous path	1.5	—	Bus clock cycles	1, 2
	GPIO pin interrupt pulse width (digital glitch filter disabled, analog filter enabled) — Asynchronous path	100	—	ns	3
	GPIO pin interrupt pulse width (digital glitch filter disabled, analog filter disabled) — Asynchronous path	50	—	ns	3
	External reset pulse width (digital glitch filter disabled)	100	—	ns	3
	Mode select ( $\overline{\text{EZP\_CS}}$ ) hold time after reset deassertion	2	—	Bus clock cycles	
	Port rise and fall time (high drive strength) - 3 V				4
	• Slew disabled				
	• 1.71 ≤ V <sub>DD</sub> ≤ 2.7V	—	8	ns	
	• 2.7 ≤ V <sub>DD</sub> ≤ 3.6V	—	6	ns	
	• Slew enabled				
		—	18	ns	

Table continues on the next page...

**Table 11. General switching specifications (continued)**

Symbol	Description	Min.	Max.	Unit	Notes
	<ul style="list-style-type: none"> <li>• <math>1.71 \leq V_{DD} \leq 2.7V</math></li> <li>• <math>2.7 \leq V_{DD} \leq 3.6V</math></li> </ul>	—	12	ns	
	Port rise and fall time (high drive strength) - 5 V <ul style="list-style-type: none"> <li>• Slew disabled               <ul style="list-style-type: none"> <li>• <math>1.71 \leq V_{DD} \leq 2.7V</math></li> <li>• <math>2.7 \leq V_{DD} \leq 3.6V</math></li> </ul> </li> <li>• Slew enabled               <ul style="list-style-type: none"> <li>• <math>1.71 \leq V_{DD} \leq 2.7V</math></li> <li>• <math>2.7 \leq V_{DD} \leq 3.6V</math></li> </ul> </li> </ul>	—	6	ns	4
		—	4	ns	
		—	24	ns	
		—	14	ns	
	Port rise and fall time (low drive strength) - 3 V <ul style="list-style-type: none"> <li>• Slew disabled               <ul style="list-style-type: none"> <li>• <math>1.71 \leq V_{DD} \leq 2.7V</math></li> <li>• <math>2.7 \leq V_{DD} \leq 3.6V</math></li> </ul> </li> <li>• Slew enabled               <ul style="list-style-type: none"> <li>• <math>1.71 \leq V_{DD} \leq 2.7V</math></li> <li>• <math>2.7 \leq V_{DD} \leq 3.6V</math></li> </ul> </li> </ul>	—	12	ns	5
		—	6	ns	
		—	24	ns	
		—	16	ns	
	Port rise and fall time (low drive strength) - 5 V <ul style="list-style-type: none"> <li>• Slew disabled               <ul style="list-style-type: none"> <li>• <math>1.71 \leq V_{DD} \leq 2.7V</math></li> <li>• <math>2.7 \leq V_{DD} \leq 3.6V</math></li> </ul> </li> <li>• Slew enabled               <ul style="list-style-type: none"> <li>• <math>1.71 \leq V_{DD} \leq 2.7V</math></li> <li>• <math>2.7 \leq V_{DD} \leq 3.6V</math></li> </ul> </li> </ul>	—	17	ns	5
		—	10	ns	
		—	36	ns	
		—	20	ns	

1. This is the minimum pulse width that is guaranteed to pass through the pin synchronization circuitry. Shorter pulses may or may not be recognized. In Stop, VLPS, LLS, and VLLSx modes, the synchronizer is bypassed so shorter pulses can be recognized in that case.
2. The greater synchronous and asynchronous timing must be met.
3. This is the minimum pulse width that is guaranteed to be recognized as a pin interrupt request in Stop, VLPS, LLS, and VLLSx modes.
4. 25 pF load
5. 15 pF load

## 2.4 Thermal specifications

## 2.4.1 Thermal operating requirements

**Table 12. Thermal operating requirements**

Symbol	Description	Min.	Max.	Unit
T <sub>J</sub>	Die junction temperature	-40	125	°C
T <sub>A</sub>	Ambient temperature <sup>1</sup>	-40	105	°C

1. Maximum T<sub>A</sub> can be exceeded only if the user ensures that T<sub>J</sub> does not exceed maximum T<sub>J</sub>. The simplest method to determine T<sub>J</sub> is:

$$T_J = T_A + R_{\theta JA} \times \text{chip power dissipation}$$

## 2.4.2 Thermal attributes

**Table 13. Thermal attributes**

Board type	Symbol	Description	144 LQFP	144 MAPBGA	121 XFBGA	100 LQFP	Unit	Notes
Single-layer (1s)	R <sub>θJA</sub>	Thermal resistance, junction to ambient (natural convection)	51	38.1	33.3	51	°C/W	1
Four-layer (2s2p)	R <sub>θJA</sub>	Thermal resistance, junction to ambient (natural convection)	43	21.6	21.1	39	°C/W	1
Single-layer (1s)	R <sub>θJMA</sub>	Thermal resistance, junction to ambient (200 ft./min. air speed)	42	30.8	26.2	41	°C/W	1
Four-layer (2s2p)	R <sub>θJMA</sub>	Thermal resistance, junction to ambient (200 ft./min. air speed)	36	18	17.8	32	°C/W	1
—	R <sub>θJB</sub>	Thermal resistance, junction to board	30	16.5	16.3	24	°C/W	2
—	R <sub>θJC</sub>	Thermal resistance,	11	8.9	12	11	°C/W	3

Table continues on the next page...

**Table 13. Thermal attributes (continued)**

Board type	Symbol	Description	144 LQFP	144 MAPBGA	121 XFBGA	100 LQFP	Unit	Notes
		junction to case						
—	$\Psi_{JT}$	Thermal characterization parameter, junction to package top outside center (natural convection)	2	0.9	0.2	2	°C/W	4

1. Determined according to JEDEC Standard JESD51-2, *Integrated Circuits Thermal Test Method Environmental Conditions—Natural Convection (Still Air)*, or EIA/JEDEC Standard JESD51-6, *Integrated Circuit Thermal Test Method Environmental Conditions—Forced Convection (Moving Air)*.
2. Determined according to JEDEC Standard JESD51-8, *Integrated Circuit Thermal Test Method Environmental Conditions—Junction-to-Board*.
3. Determined according to Method 1012.1 of MIL-STD 883, *Test Method Standard, Microcircuits*, with the cold plate temperature used for the case temperature. The value includes the thermal resistance of the interface material between the top of the package and the cold plate.
4. Determined according to JEDEC Standard JESD51-2, *Integrated Circuits Thermal Test Method Environmental Conditions—Natural Convection (Still Air)*.

## 3 Peripheral operating requirements and behaviors

### 3.1 Core modules

#### 3.1.1 Debug trace timing specifications

**Table 14. Debug trace operating behaviors**

Symbol	Description	Min.	Max.	Unit
$T_{cyc}$	Clock period	Frequency dependent		MHz
$T_{wl}$	Low pulse width	2	—	ns
$T_{wh}$	High pulse width	2	—	ns
$T_r$	Clock and data rise time	—	3	ns
$T_f$	Clock and data fall time	—	3	ns
$T_s$	Data setup	1.5	—	ns
$T_h$	Data hold	1	—	ns

Peripheral operating requirements and behaviors

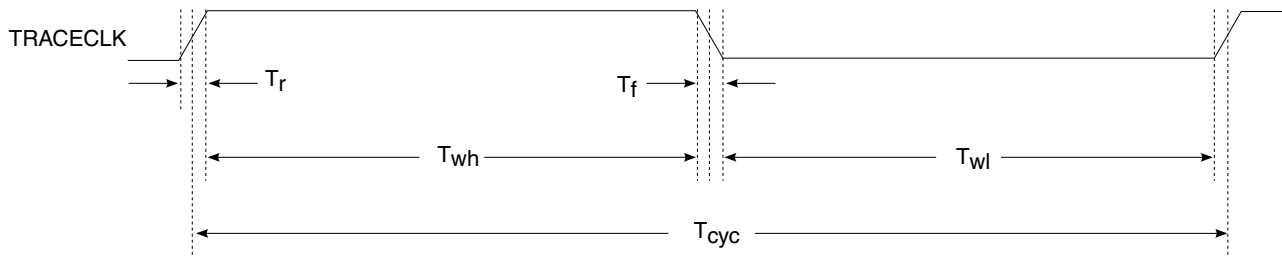

Figure 5. TRACE\_CLKOUT specifications

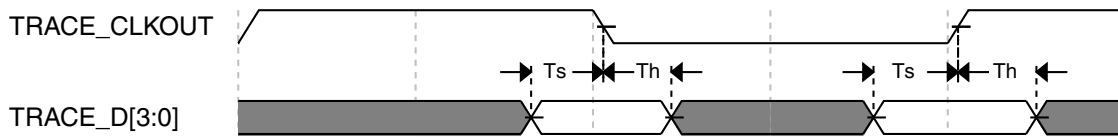

Figure 6. Trace data specifications

3.1.2 JTAG electricals

Table 15. JTAG limited voltage range electricals

Symbol	Description	Min.	Max.	Unit
	Operating voltage	2.7	3.6	V
J1	TCLK frequency of operation <ul style="list-style-type: none"> <li>• Boundary Scan</li> <li>• JTAG and CJTAG</li> <li>• Serial Wire Debug</li> </ul>	0	10	MHz
J2	TCLK cycle period	1/J1	—	ns
J3	TCLK clock pulse width <ul style="list-style-type: none"> <li>• Boundary Scan</li> <li>• JTAG and CJTAG</li> <li>• Serial Wire Debug</li> </ul>	50	—	ns
J4	TCLK rise and fall times	—	3	ns
J5	Boundary scan input data setup time to TCLK rise	20	—	ns
J6	Boundary scan input data hold time after TCLK rise	2.6	—	ns
J7	TCLK low to boundary scan output data valid	—	25	ns
J8	TCLK low to boundary scan output high-Z	—	25	ns
J9	TMS, TDI input data setup time to TCLK rise	8	—	ns
J10	TMS, TDI input data hold time after TCLK rise	1	—	ns

Table continues on the next page...

**Table 15. JTAG limited voltage range electricals (continued)**

Symbol	Description	Min.	Max.	Unit
J11	TCLK low to TDO data valid	—	17	ns
J12	TCLK low to TDO high-Z	—	17	ns
J13	$\overline{\text{TRST}}$ assert time	100	—	ns
J14	$\overline{\text{TRST}}$ setup time (negation) to TCLK high	8	—	ns

**Table 16. JTAG full voltage range electricals**

Symbol	Description	Min.	Max.	Unit
	Operating voltage	1.71	3.6	V
J1	TCLK frequency of operation <ul style="list-style-type: none"> <li>• Boundary Scan</li> <li>• JTAG and CJTAG</li> <li>• Serial Wire Debug</li> </ul>	0 0 0	10 20 40	MHz
J2	TCLK cycle period	1/J1	—	ns
J3	TCLK clock pulse width <ul style="list-style-type: none"> <li>• Boundary Scan</li> <li>• JTAG and CJTAG</li> <li>• Serial Wire Debug</li> </ul>	50 25 12.5	— — —	ns ns ns
J4	TCLK rise and fall times	—	3	ns
J5	Boundary scan input data setup time to TCLK rise	20	—	ns
J6	Boundary scan input data hold time after TCLK rise	0	—	ns
J7	TCLK low to boundary scan output data valid	—	25	ns
J8	TCLK low to boundary scan output high-Z	—	25	ns
J9	TMS, TDI input data setup time to TCLK rise	8	—	ns
J10	TMS, TDI input data hold time after TCLK rise	2.9	—	ns
J11	TCLK low to TDO data valid	—	22.1	ns
J12	TCLK low to TDO high-Z	—	22.1	ns
J13	$\overline{\text{TRST}}$ assert time	100	—	ns
J14	$\overline{\text{TRST}}$ setup time (negation) to TCLK high	8	—	ns

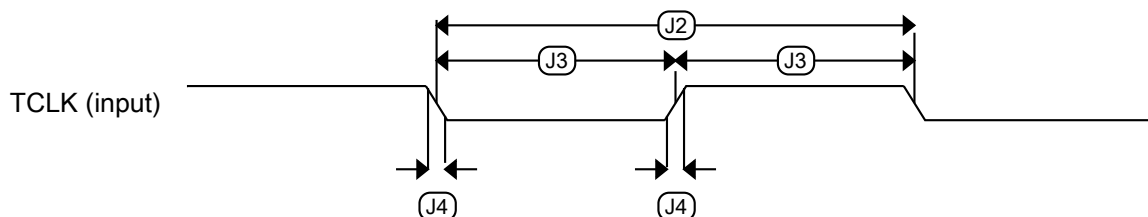
**Figure 7. Test clock input timing**

Peripheral operating requirements and behaviors

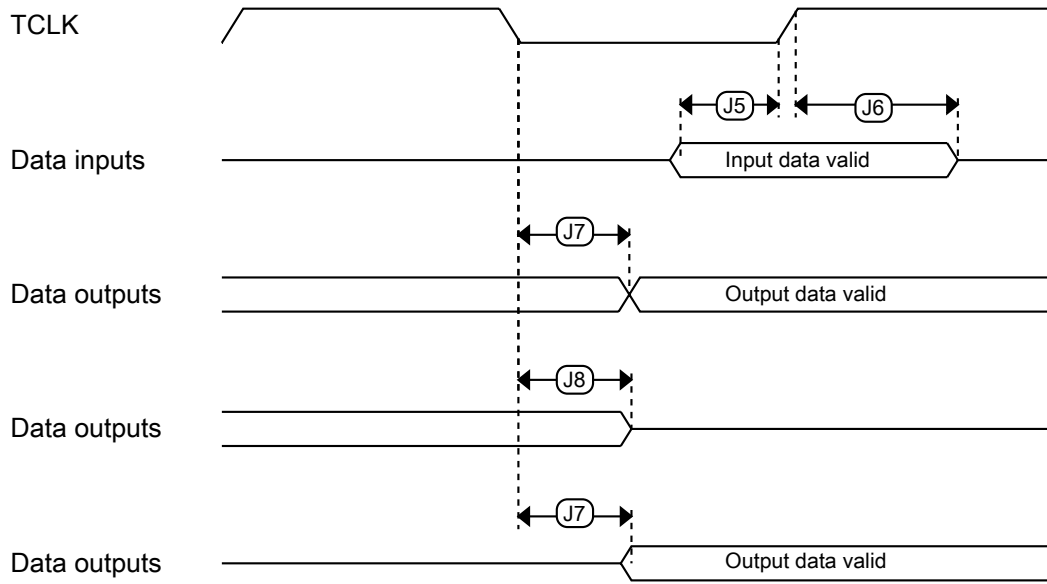

Figure 8. Boundary scan (JTAG) timing

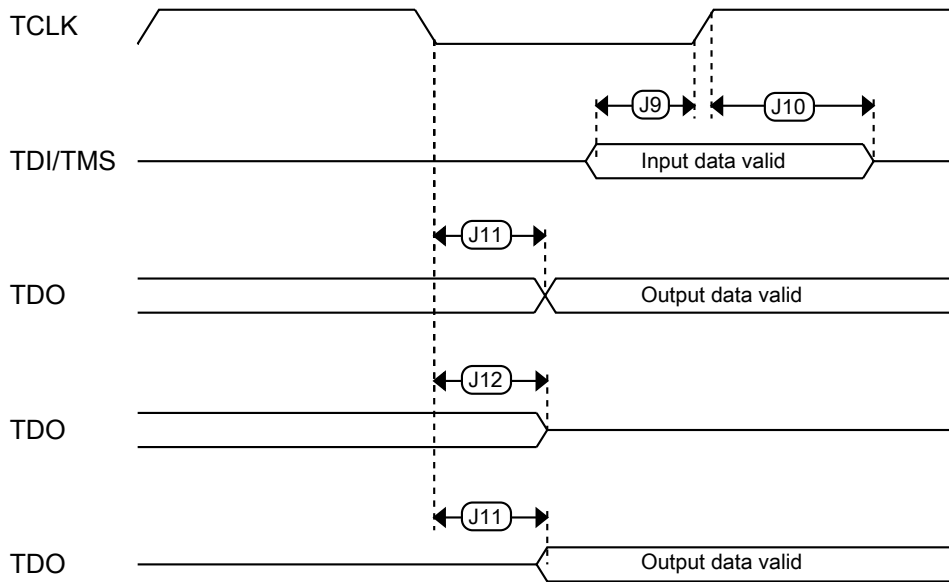

Figure 9. Test Access Port timing





Figure 10. TRST timing

## 3.2 System modules

There are no specifications necessary for the device's system modules.

## 3.3 Clock modules

### 3.3.1 MCG specifications

Table 17. MCG specifications

Symbol	Description	Min.	Typ.	Max.	Unit	Notes
$f_{ints\_ft}$	Internal reference frequency (slow clock) — factory trimmed at nominal VDD and 25 °C	—	32.768	—	kHz	
$f_{ints\_t}$	Internal reference frequency (slow clock) — user trimmed	31.25	—	39.0625	kHz	
$I_{ints}$	Internal reference (slow clock) current	—	20	—	μA	
$\Delta f_{dco\_res\_t}$	Resolution of trimmed average DCO output frequency at fixed voltage and temperature — using SCTRIM and SCFTRIM	—	± 0.3	± 0.6	% $f_{dco}$	1
$\Delta f_{dco\_res\_t}$	Resolution of trimmed average DCO output frequency at fixed voltage and temperature — using SCTRIM only	—	± 0.2	± 0.5	% $f_{dco}$	1
$\Delta f_{dco\_t}$	Total deviation of trimmed average DCO output frequency over voltage and temperature	—	± 0.5	± 2	% $f_{dco}$	1, 2
$\Delta f_{dco\_t}$	Total deviation of trimmed average DCO output frequency over fixed voltage and temperature range of 0–70°C	—	± 0.3	± 1	% $f_{dco}$	1
$f_{intf\_ft}$	Internal reference frequency (fast clock) — factory trimmed at nominal VDD and 25°C	—	4	—	MHz	
$f_{intf\_t}$	Internal reference frequency (fast clock) — user trimmed at nominal VDD and 25 °C	3	—	5	MHz	
$I_{intf}$	Internal reference (fast clock) current	—	25	—	μA	

Table continues on the next page...

Table 17. MCG specifications (continued)

Symbol	Description	Min.	Typ.	Max.	Unit	Notes	
$f_{loc\_low}$	Loss of external clock minimum frequency — RANGE = 00	$(3/5) \times f_{ints\_t}$	—	—	kHz		
$f_{loc\_high}$	Loss of external clock minimum frequency — RANGE = 01, 10, or 11	$(16/5) \times f_{ints\_t}$	—	—	kHz		
FLL							
$f_{fill\_ref}$	FLL reference frequency range	31.25	—	39.0625	kHz		
$f_{dco}$	DCO output frequency range	Low range (DRS=00) $640 \times f_{fill\_ref}$	20	20.97	25	MHz	3, 4
		Mid range (DRS=01) $1280 \times f_{fill\_ref}$	40	41.94	50	MHz	
		Mid-high range (DRS=10) $1920 \times f_{fill\_ref}$	60	62.91	75	MHz	
		High range (DRS=11) $2560 \times f_{fill\_ref}$	80	83.89	100	MHz	
$f_{dco\_t\_DMX32}$	DCO output frequency	Low range (DRS=00) $732 \times f_{fill\_ref}$	—	23.99	—	MHz	5, 6
		Mid range (DRS=01) $1464 \times f_{fill\_ref}$	—	47.97	—	MHz	
		Mid-high range (DRS=10) $2197 \times f_{fill\_ref}$	—	71.99	—	MHz	
		High range (DRS=11) $2929 \times f_{fill\_ref}$	—	95.98	—	MHz	
$J_{cyc\_fill}$	FLL period jitter <ul style="list-style-type: none"> <li><math>f_{DCO} = 48</math> MHz</li> <li><math>f_{DCO} = 98</math> MHz</li> </ul>	—	180 150	—	ps		
$t_{fill\_acquire}$	FLL target frequency acquisition time	—	—	1	ms	7	
PLL							
$f_{vco}$	VCO operating frequency	48.0	—	120	MHz		
$I_{pll}$	PLL operating current <ul style="list-style-type: none"> <li>PLL @ 96 MHz (<math>f_{osc\_hi\_1} = 8</math> MHz, <math>f_{pll\_ref} = 2</math> MHz, VDIV multiplier = 48)</li> </ul>	—	1060	—	$\mu$ A	8	
$I_{pll}$	PLL operating current <ul style="list-style-type: none"> <li>PLL @ 48 MHz (<math>f_{osc\_hi\_1} = 8</math> MHz, <math>f_{pll\_ref} = 2</math> MHz, VDIV multiplier = 24)</li> </ul>	—	600	—	$\mu$ A	8	
$f_{pll\_ref}$	PLL reference frequency range	2.0	—	4.0	MHz		
$J_{cyc\_pll}$	PLL period jitter (RMS) <ul style="list-style-type: none"> <li><math>f_{vco} = 48</math> MHz</li> <li><math>f_{vco} = 120</math> MHz</li> </ul>	—	120	—	ps	9	
		—	80	—	ps		
$J_{acc\_pll}$	PLL accumulated jitter over 1 $\mu$ s (RMS)					9	

Table continues on the next page...

**Table 17. MCG specifications (continued)**

Symbol	Description	Min.	Typ.	Max.	Unit	Notes
	<ul style="list-style-type: none"> <li><math>f_{vco} = 48 \text{ MHz}</math></li> <li><math>f_{vco} = 120 \text{ MHz}</math></li> </ul>	—	1350	—	ps	
		—	600	—	ps	
$D_{lock}$	Lock entry frequency tolerance	$\pm 1.49$	—	$\pm 2.98$	%	
$D_{unl}$	Lock exit frequency tolerance	$\pm 4.47$	—	$\pm 5.97$	%	
$t_{pll\_lock}$	Lock detector detection time	—	—	$150 \times 10^{-6} + 1075(1/f_{pll\_ref})$	s	10

1. This parameter is measured with the internal reference (slow clock) being used as a reference to the FLL (FEI clock mode).
2.  $2 \text{ V} \leq VDD \leq 3.6 \text{ V}$ .
3. These typical values listed are with the slow internal reference clock (FEI) using factory trim and DMX32=0.
4. The resulting system clock frequencies should not exceed their maximum specified values. The DCO frequency deviation ( $\Delta f_{dco\_t}$ ) over voltage and temperature should be considered.
5. These typical values listed are with the slow internal reference clock (FEI) using factory trim and DMX32=1.
6. The resulting clock frequency must not exceed the maximum specified clock frequency of the device.
7. This specification applies to any time the FLL reference source or reference divider is changed, trim value is changed, DMX32 bit is changed, DRS bits are changed, or changing from FLL disabled (BLPE, BLPI) to FLL enabled (FEI, FEE, FBE, FBI). If a crystal/resonator is being used as the reference, this specification assumes it is already running.
8. Excludes any oscillator currents that are also consuming power while PLL is in operation.
9. This specification was obtained using a NXP developed PCB. PLL jitter is dependent on the noise characteristics of each PCB and results will vary.
10. This specification applies to any time the PLL VCO divider or reference divider is changed, or changing from PLL disabled (BLPE, BLPI) to PLL enabled (PBE, PEE). If a crystal/resonator is being used as the reference, this specification assumes it is already running.

### 3.3.2 IRC48M specifications

**Table 18. IRC48M specifications**

Symbol	Description	Min.	Typ.	Max.	Unit	Notes
$V_{DD}$	Supply voltage	1.71	—	3.6	V	
$I_{DD48M}$	Supply current	—	400	500	$\mu\text{A}$	
$f_{irc48m}$	Internal reference frequency	—	48	—	MHz	
$\Delta f_{irc48m\_ol\_lv}$	Open loop total deviation of IRC48M frequency at low voltage ( $VDD=1.71\text{V}-1.89\text{V}$ ) over full temperature <ul style="list-style-type: none"> <li>Regulator disable (USB_CLK_RECOVER_IRC_EN[REG_EN]=0)</li> <li>Regulator enable (USB_CLK_RECOVER_IRC_EN[REG_EN]=1)</li> </ul>	—	$\pm 0.5$	$\pm 1.5$	$\%f_{irc48m}$	1
$\Delta f_{irc48m\_ol\_hv}$	Open loop total deviation of IRC48M frequency at high voltage ( $VDD=1.89\text{V}-3.6\text{V}$ ) over full temperature <ul style="list-style-type: none"> <li>Regulator enable (USB_CLK_RECOVER_IRC_EN[REG_EN]=1)</li> </ul>	—	$\pm 0.5$	$\pm 1.5$	$\%f_{irc48m}$	1

Table continues on the next page...

**Table 18. IRC48M specifications (continued)**

Symbol	Description	Min.	Typ.	Max.	Unit	Notes
$\Delta f_{irc48m\_ol\_hv}$	Open loop total deviation of IRC48M frequency at high voltage (VDD=1.89V-3.6V) over 0 to 85 °C <ul style="list-style-type: none"> <li>Regulator enable (USB_CLK_RECOVER_IRC_EN[REG_EN]=1)</li> </ul>	—	± 0.5	± 1.0	% $f_{irc48m}$	1
$\Delta f_{irc48m\_cl}$	Closed loop total deviation of IRC48M frequency over voltage and temperature	—	—	± 0.1	% $f_{host}$	2
$J_{cyc\_irc48m}$	Period Jitter (RMS)	—	35	150	ps	
$t_{irc48mst}$	Startup time	—	2	3	μs	3

1. The maximum value represents characterized results equivalent to the mean plus or minus three times the standard deviation (mean ± 3 sigma)
2. Closed loop operation of the IRC48M is only feasible for USB device operation; it is not usable for USB host operation. It is enabled by configuring for USB Device, selecting IRC48M as USB clock source, and enabling the clock recover function (USB\_CLK\_RECOVER\_IRC\_CTRL[CLOCK\_RECOVER\_EN]=1, USB\_CLK\_RECOVER\_IRC\_EN[IRC\_EN]=1).
3. IRC48M startup time is defined as the time between clock enablement and clock availability for system use. Enable the clock by setting USB\_CLK\_RECOVER\_IRC\_EN[IRC\_EN]=1.

### 3.3.3 Oscillator electrical specifications

#### 3.3.3.1 Oscillator DC electrical specifications

**Table 19. Oscillator DC electrical specifications**

Symbol	Description	Min.	Typ.	Max.	Unit	Notes
$V_{DD}$	Supply voltage	1.71	—	3.6	V	
$I_{DDOSC}$	Supply current — low-power mode (HGO=0) <ul style="list-style-type: none"> <li>32 kHz</li> <li>4 MHz</li> <li>8 MHz (RANGE=01)</li> <li>16 MHz</li> <li>24 MHz</li> <li>32 MHz</li> </ul>	—	500	—	nA	1
$I_{DDOSC}$	Supply current — high-gain mode (HGO=1) <ul style="list-style-type: none"> <li>32 kHz</li> <li>4 MHz</li> <li>8 MHz (RANGE=01)</li> <li>16 MHz</li> <li>24 MHz</li> <li>32 MHz</li> </ul>	—	25	—	μA	1
		—	400	—	μA	
		—	500	—	μA	
		—	2.5	—	mA	
		—	3	—	mA	
		—	4	—	mA	

Table continues on the next page...

**Table 19. Oscillator DC electrical specifications (continued)**

Symbol	Description	Min.	Typ.	Max.	Unit	Notes
$C_x$	EXTAL load capacitance	—	—	—		2, 3
$C_y$	XTAL load capacitance	—	—	—		2, 3
$R_F$	Feedback resistor — low-frequency, low-power mode (HGO=0)	—	—	—	M $\Omega$	2, 4
	Feedback resistor — low-frequency, high-gain mode (HGO=1)	—	10	—	M $\Omega$	
	Feedback resistor — high-frequency, low-power mode (HGO=0)	—	—	—	M $\Omega$	
	Feedback resistor — high-frequency, high-gain mode (HGO=1)	—	1	—	M $\Omega$	
$R_S$	Series resistor — low-frequency, low-power mode (HGO=0)	—	—	—	k $\Omega$	
	Series resistor — low-frequency, high-gain mode (HGO=1)	—	200	—	k $\Omega$	
	Series resistor — high-frequency, low-power mode (HGO=0)	—	—	—	k $\Omega$	
	Series resistor — high-frequency, high-gain mode (HGO=1)	—	0	—	k $\Omega$	
$V_{pp}$ <sup>5</sup>	Peak-to-peak amplitude of oscillation (oscillator mode) — low-frequency, low-power mode (HGO=0)	—	0.6	—	V	
	Peak-to-peak amplitude of oscillation (oscillator mode) — low-frequency, high-gain mode (HGO=1)	—	$V_{DD}$	—	V	
	Peak-to-peak amplitude of oscillation (oscillator mode) — high-frequency, low-power mode (HGO=0)	—	0.6	—	V	
	Peak-to-peak amplitude of oscillation (oscillator mode) — high-frequency, high-gain mode (HGO=1)	—	$V_{DD}$	—	V	

1.  $V_{DD}$ =3.3 V, Temperature =25 °C
2. See crystal or resonator manufacturer's recommendation
3.  $C_x$  and  $C_y$  can be provided by using either integrated capacitors or external components.
4. When low-power mode is selected,  $R_F$  is integrated and must not be attached externally.
5. The EXTAL and XTAL pins should only be connected to required oscillator components and must not be connected to any other device.

### 3.3.3.2 Oscillator frequency specifications

**Table 20. Oscillator frequency specifications**

Symbol	Description	Min.	Typ.	Max.	Unit	Notes
$f_{osc\_lo}$	Oscillator crystal or resonator frequency — low-frequency mode (MCG_C2[RANGE]=00)	32	—	40	kHz	
$f_{osc\_hi\_1}$	Oscillator crystal or resonator frequency — high-frequency mode (low range) (MCG_C2[RANGE]=01)	3	—	8	MHz	
$f_{osc\_hi\_2}$	Oscillator crystal or resonator frequency — high frequency mode (high range) (MCG_C2[RANGE]=1x)	8	—	32	MHz	
$f_{ec\_extal}$	Input clock frequency (external clock mode)	—	—	50	MHz	1, 2
$t_{dc\_extal}$	Input clock duty cycle (external clock mode)	40	50	60	%	
$t_{cst}$	Crystal startup time — 32 kHz low-frequency, low-power mode (HGO=0)	—	750	—	ms	3, 4
	Crystal startup time — 32 kHz low-frequency, high-gain mode (HGO=1)	—	250	—	ms	
	Crystal startup time — 8 MHz high-frequency (MCG_C2[RANGE]=01), low-power mode (HGO=0)	—	0.6	—	ms	
	Crystal startup time — 8 MHz high-frequency (MCG_C2[RANGE]=01), high-gain mode (HGO=1)	—	1	—	ms	

1. Other frequency limits may apply when external clock is being used as a reference for the FLL
2. When transitioning from FEI or FBI to FBE mode, restrict the frequency of the input clock so that, when it is divided by FRDIV, it remains within the limits of the DCO input clock frequency.
3. Proper PC board layout procedures must be followed to achieve specifications.
4. Crystal startup time is defined as the time between the oscillator being enabled and the OSCINIT bit in the MCG\_S register being set.

#### NOTE

The 32 kHz oscillator works in low power mode by default and cannot be moved into high power/gain mode.

### 3.3.4 32 kHz oscillator electrical characteristics

#### 3.3.4.1 32 kHz oscillator DC electrical specifications

**Table 21. 32kHz oscillator DC electrical specifications**

Symbol	Description	Min.	Typ.	Max.	Unit
$V_{BAT}$	Supply voltage	1.71	—	3.6	V
$R_F$	Internal feedback resistor	—	100	—	M $\Omega$

*Table continues on the next page...*

**Table 21. 32kHz oscillator DC electrical specifications (continued)**

Symbol	Description	Min.	Typ.	Max.	Unit
$C_{para}$	Parasitical capacitance of EXTAL32 and XTAL32	—	5	7	pF
$V_{pp}^1$	Peak-to-peak amplitude of oscillation	—	0.6	—	V

1. When a crystal is being used with the 32 kHz oscillator, the EXTAL32 and XTAL32 pins should only be connected to required oscillator components and must not be connected to any other devices.

### 3.3.4.2 32 kHz oscillator frequency specifications

**Table 22. 32 kHz oscillator frequency specifications**

Symbol	Description	Min.	Typ.	Max.	Unit	Notes
$f_{osc\_lo}$	Oscillator crystal	—	32.768	—	kHz	
$t_{start}$	Crystal start-up time	—	1000	—	ms	1
$f_{ec\_extal32}$	Externally provided input clock frequency	—	32.768	—	kHz	2
$V_{ec\_extal32}$	Externally provided input clock amplitude	700	—	$V_{BAT}$	mV	2, 3

1. Proper PC board layout procedures must be followed to achieve specifications.
2. This specification is for an externally supplied clock driven to EXTAL32 and does not apply to any other clock input. The oscillator remains enabled and XTAL32 must be left unconnected.
3. The parameter specified is a peak-to-peak value and  $V_{IH}$  and  $V_{IL}$  specifications do not apply. The voltage of the applied clock must be within the range of  $V_{SS}$  to  $V_{BAT}$ .

## 3.4 Memories and memory interfaces

### 3.4.1 Flash (FTFE) electrical specifications

This section describes the electrical characteristics of the FTFE module.

#### 3.4.1.1 Flash timing specifications — program and erase

The following specifications represent the amount of time the internal charge pumps are active and do not include command overhead.

**Table 23. NVM program/erase timing specifications**

Symbol	Description	Min.	Typ.	Max.	Unit	Notes
$t_{hvp gm8}$	Program Phrase high-voltage time	—	7.5	18	$\mu$ s	
$t_{hversscr}$	Erase Flash Sector high-voltage time	—	13	113	ms	1
$t_{hversblk128k}$	Erase Flash Block high-voltage time for 128 KB	—	104	904	ms	1
$t_{hversblk512k}$	Erase Flash Block high-voltage time for 512 KB	—	416	3616	ms	1

## Peripheral operating requirements and behaviors

1. Maximum time based on expectations at cycling end-of-life.

### 3.4.1.2 Flash timing specifications — commands

**Table 24. Flash command timing specifications**

Symbol	Description	Min.	Typ.	Max.	Unit	Notes
$t_{rd1blk128k}$	Read 1s Block execution time	—	—	0.5	ms	
$t_{rd1blk512k}$	<ul style="list-style-type: none"> <li>128 KB data flash</li> <li>512 KB program flash</li> </ul>	—	—	1.8	ms	
$t_{rd1sec4k}$	Read 1s Section execution time (4 KB flash)	—	—	100	$\mu$ s	1
$t_{pgmchk}$	Program Check execution time	—	—	95	$\mu$ s	1
$t_{rdsrc}$	Read Resource execution time	—	—	40	$\mu$ s	1
$t_{pgm8}$	Program Phrase execution time	—	90	150	$\mu$ s	
$t_{ersblk128k}$	Erase Flash Block execution time	—	110	925	ms	2
$t_{ersblk512k}$	<ul style="list-style-type: none"> <li>128 KB data flash</li> <li>512 KB program flash</li> </ul>	—	435	3700	ms	
$t_{ersscr}$	Erase Flash Sector execution time	—	15	115	ms	2
$t_{pgmsec1k}$	Program Section execution time (1KB flash)	—	5	—	ms	
$t_{rd1allx}$	Read 1s All Blocks execution time	—	—	2.2	ms	
$t_{rd1alln}$	<ul style="list-style-type: none"> <li>FlexNVM devices</li> <li>Program flash only devices</li> </ul>	—	—	3.4	ms	
$t_{rdonce}$	Read Once execution time	—	—	30	$\mu$ s	1
$t_{pgmonce}$	Program Once execution time	—	70	—	$\mu$ s	
$t_{ersall}$	Erase All Blocks execution time	—	870	7400	ms	2
$t_{vfykey}$	Verify Backdoor Access Key execution time	—	—	30	$\mu$ s	1
$t_{swapx01}$	Swap Control execution time	—	200	—	$\mu$ s	
$t_{swapx02}$	<ul style="list-style-type: none"> <li>control code 0x01</li> <li>control code 0x02</li> </ul>	—	70	150	$\mu$ s	
$t_{swapx04}$	<ul style="list-style-type: none"> <li>control code 0x04</li> </ul>	—	70	150	$\mu$ s	
$t_{swapx08}$	<ul style="list-style-type: none"> <li>control code 0x08</li> </ul>	—	—	30	$\mu$ s	
$t_{pgmpart32k}$	Program Partition for EEPROM execution time	—	70	—	ms	
$t_{pgmpart128k}$	<ul style="list-style-type: none"> <li>32 KB FlexNVM</li> <li>128 KB FlexNVM</li> </ul>	—	75	—	ms	
$t_{setramff}$	Set FlexRAM Function execution time:	—	70	—	$\mu$ s	
$t_{setram32k}$	<ul style="list-style-type: none"> <li>Control Code 0xFF</li> <li>32 KB EEPROM backup</li> </ul>	—	0.8	1.2	ms	
$t_{setram64k}$	<ul style="list-style-type: none"> <li>64 KB EEPROM backup</li> </ul>	—	1.3	1.9	ms	
$t_{setram128k}$	<ul style="list-style-type: none"> <li>128 KB EEPROM backup</li> </ul>	—	2.4	3.1	ms	

Table continues on the next page...



**Table 24. Flash command timing specifications (continued)**

Symbol	Description	Min.	Typ.	Max.	Unit	Notes
$t_{\text{eewr8bers}}$	Byte-write to erased FlexRAM location execution time	—	175	275	$\mu\text{s}$	3
$t_{\text{eewr8b32k}}$	Byte-write to FlexRAM execution time: <ul style="list-style-type: none"> <li>• 32 KB EEPROM backup</li> <li>• 64 KB EEPROM backup</li> <li>• 128 KB EEPROM backup</li> </ul>	—	385	1700	$\mu\text{s}$	
$t_{\text{eewr8b64k}}$		—	475	2000	$\mu\text{s}$	
$t_{\text{eewr8b128k}}$		—	650	2350	$\mu\text{s}$	
$t_{\text{eewr16bers}}$	16-bit write to erased FlexRAM location execution time	—	175	275	$\mu\text{s}$	
$t_{\text{eewr16b32k}}$	16-bit write to FlexRAM execution time: <ul style="list-style-type: none"> <li>• 32 KB EEPROM backup</li> <li>• 64 KB EEPROM backup</li> <li>• 128 KB EEPROM backup</li> </ul>	—	385	1700	$\mu\text{s}$	
$t_{\text{eewr16b64k}}$		—	475	2000	$\mu\text{s}$	
$t_{\text{eewr16b128k}}$		—	650	2350	$\mu\text{s}$	
$t_{\text{eewr32bers}}$	32-bit write to erased FlexRAM location execution time	—	360	550	$\mu\text{s}$	
$t_{\text{eewr32b32k}}$	32-bit write to FlexRAM execution time: <ul style="list-style-type: none"> <li>• 32 KB EEPROM backup</li> <li>• 64 KB EEPROM backup</li> <li>• 128 KB EEPROM backup</li> </ul>	—	630	2000	$\mu\text{s}$	
$t_{\text{eewr32b64k}}$		—	810	2250	$\mu\text{s}$	
$t_{\text{eewr32b128k}}$		—	1200	2650	$\mu\text{s}$	

1. Assumes 25MHz or greater flash clock frequency.
2. Maximum times for erase parameters based on expectations at cycling end-of-life.
3. For byte-writes to an erased FlexRAM location, the aligned word containing the byte must be erased.

### 3.4.1.3 Flash high voltage current behaviors

**Table 25. Flash high voltage current behaviors**

Symbol	Description	Min.	Typ.	Max.	Unit
$I_{\text{DD\_PGM}}$	Average current adder during high voltage flash programming operation	—	3.5	7.5	mA
$I_{\text{DD\_ERS}}$	Average current adder during high voltage flash erase operation	—	1.5	4.0	mA

### 3.4.1.4 Reliability specifications

**Table 26. NVM reliability specifications**

Symbol	Description	Min.	Typ. <sup>1</sup>	Max.	Unit	Notes
Program Flash						
$t_{\text{nvmp10k}}$	Data retention after up to 10 K cycles	5	50	—	years	

Table continues on the next page...

**Table 26. NVM reliability specifications (continued)**

Symbol	Description	Min.	Typ. <sup>1</sup>	Max.	Unit	Notes
$t_{nvmretp1k}$	Data retention after up to 1 K cycles	20	100	—	years	
$n_{nvmcyep}$	Cycling endurance	10 K	50 K	—	cycles	2
Data Flash						
$t_{nvmretd10k}$	Data retention after up to 10 K cycles	5	50	—	years	
$t_{nvmretd1k}$	Data retention after up to 1 K cycles	20	100	—	years	
$n_{nvmcyed}$	Cycling endurance	10 K	50 K	—	cycles	2
FlexRAM as EEPROM						
$t_{nvmretee100}$	Data retention up to 100% of write endurance	5	50	—	years	
$t_{nvmretee10}$	Data retention up to 10% of write endurance	20	100	—	years	
$n_{nvmcycee}$	Cycling endurance for EEPROM backup	20 K	50 K	—	cycles	2
	Write endurance					3
$n_{nvmwree16}$	• EEPROM backup to FlexRAM ratio = 16	140 K	400 K	—	writes	
$n_{nvmwree128}$	• EEPROM backup to FlexRAM ratio = 128	1.26 M	3.2 M	—	writes	
$n_{nvmwree512}$	• EEPROM backup to FlexRAM ratio = 512	5 M	12.8 M	—	writes	
$n_{nvmwree2k}$	• EEPROM backup to FlexRAM ratio = 2,048	20 M	50 M	—	writes	
$n_{nvmwree4k}$	• EEPROM backup to FlexRAM ratio = 4,096	40 M	100 M	—	writes	

1. Typical data retention values are based on measured response accelerated at high temperature and derated to a constant 25°C use profile. Engineering Bulletin EB618 does not apply to this technology. Typical endurance defined in Engineering Bulletin EB619.
2. Cycling endurance represents number of program/erase cycles at  $-40^{\circ}\text{C} \leq T_j \leq 125^{\circ}\text{C}$ .
3. Write endurance represents the number of writes to each FlexRAM location at  $-40^{\circ}\text{C} \leq T_j \leq 125^{\circ}\text{C}$  influenced by the cycling endurance of the FlexNVM and the allocated EEPROM backup per subsystem. Minimum and typical values assume all 16-bit or 32-bit writes to FlexRAM; all 8-bit writes result in 50% less endurance.

### 3.4.1.5 Write endurance to FlexRAM for EEPROM

When the FlexNVM partition code is not set to full data flash, the EEPROM data set size can be set to any of several non-zero values.

The bytes not assigned to data flash via the FlexNVM partition code are used by the FTFE to obtain an effective endurance increase for the EEPROM data. The built-in EEPROM record management system raises the number of program/erase cycles that can be attained prior to device wear-out by cycling the EEPROM data through a larger EEPROM NVM storage space.

While different partitions of the FlexNVM are available, the intention is that a single choice for the FlexNVM partition code and EEPROM data set size is used throughout the entire lifetime of a given application. The EEPROM endurance equation and graph shown below assume that only one configuration is ever used.

$$\text{Writes\_subsystem} = \frac{\text{EEPROM} - 2 \times \text{EESPLIT} \times \text{EESIZE}}{\text{EESPLIT} \times \text{EESIZE}} \times \text{Write\_efficiency} \times n_{\text{nvmcycee}}$$

where

- Writes\_subsystem — minimum number of writes to each FlexRAM location for subsystem (each subsystem can have different endurance)
- EEPROM — allocated FlexNVM for each EEPROM subsystem based on DEPART; entered with the Program Partition command
- EESPLIT — FlexRAM split factor for subsystem; entered with the Program Partition command
- EESIZE — allocated FlexRAM based on DEPART; entered with the Program Partition command
- Write\_efficiency —
  - 0.25 for 8-bit writes to FlexRAM
  - 0.50 for 16-bit or 32-bit writes to FlexRAM
- n<sub>nvmcycee</sub> — EEPROM-backup cycling endurance

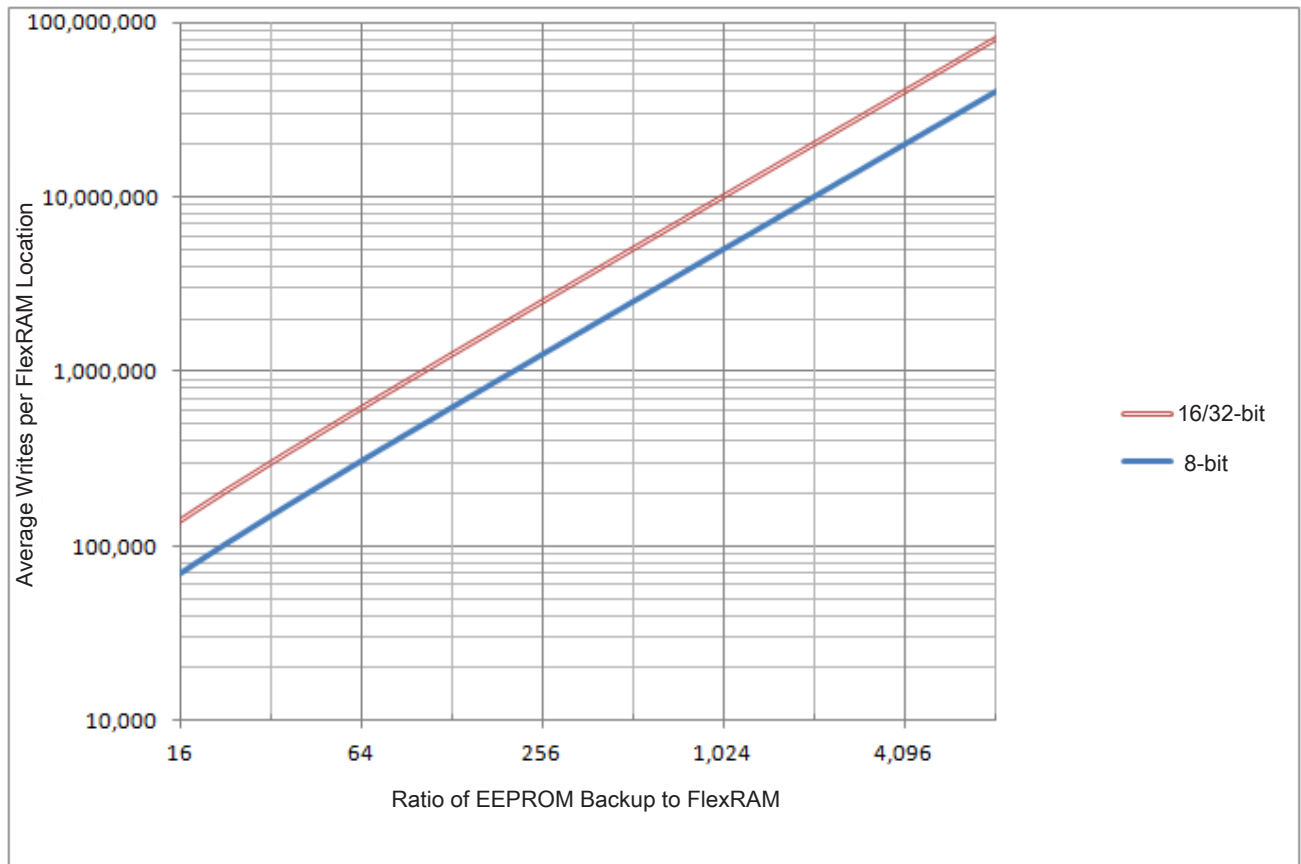

**Figure 11. EEPROM backup writes to FlexRAM**

### 3.4.2 EzPort switching specifications

Table 27. EzPort switching specifications

Num	Description	Min.	Max.	Unit
	Operating voltage	1.71	3.6	V
EP1	EZP_CK frequency of operation (all commands except READ)	—	$f_{SYS}/2$	MHz
EP1a	EZP_CK frequency of operation (READ command)	—	$f_{SYS}/8$	MHz
EP2	$\overline{EZP\_CS}$ negation to next $\overline{EZP\_CS}$ assertion	$2 \times t_{EZP\_CK}$	—	ns
EP3	$\overline{EZP\_CS}$ input valid to EZP_CK high (setup)	5	—	ns
EP4	EZP_CK high to $\overline{EZP\_CS}$ input invalid (hold)	5	—	ns
EP5	EZP_D input valid to EZP_CK high (setup)	2	—	ns
EP6	EZP_CK high to EZP_D input invalid (hold)	5	—	ns
EP7	EZP_CK low to EZP_Q output valid	—	18	ns
EP8	EZP_CK low to EZP_Q output invalid (hold)	0	—	ns
EP9	$\overline{EZP\_CS}$ negation to EZP_Q tri-state	—	12	ns

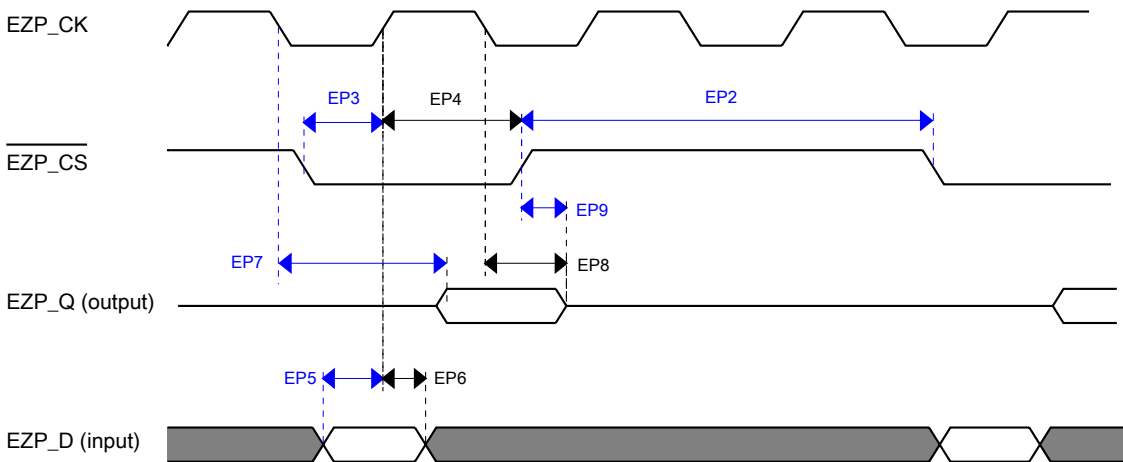

Figure 12. EzPort Timing Diagram

### 3.4.3 Flexbus switching specifications

All processor bus timings are synchronous; input setup/hold and output delay are given in respect to the rising edge of a reference clock, FB\_CLK. The FB\_CLK frequency may be the same as the internal system bus frequency or an integer divider of that frequency.

The following timing numbers indicate when data is latched or driven onto the external bus, relative to the Flexbus output clock (FB\_CLK). All other timing relationships can be derived from these values.

**Table 28. Flexbus limited voltage range switching specifications**

Num	Description	Min.	Max.	Unit	Notes
	Operating voltage	2.7	3.6	V	
	Frequency of operation	—	FB_CLK	MHz	
FB1	Clock period	20	—	ns	
FB2	Address, data, and control output valid	—	11.5	ns	1
FB3	Address, data, and control output hold	0.5	—	ns	1
FB4	Data and $\overline{\text{FB\_TA}}$ input setup	8.5	—	ns	2
FB5	Data and $\overline{\text{FB\_TA}}$ input hold	0.5	—	ns	2

1. Specification is valid for all FB\_AD[31:0],  $\overline{\text{FB\_BE/BWE}n}$ ,  $\overline{\text{FB\_CS}n}$ , FB\_OE, FB\_R/W, FB\_TBST, FB\_TSIZ[1:0], FB\_ALE, and FB\_TS.
2. Specification is valid for all FB\_AD[31:0] and  $\overline{\text{FB\_TA}}$ .

**Table 29. Flexbus full voltage range switching specifications**

Num	Description	Min.	Max.	Unit	Notes
	Operating voltage	1.71	3.6	V	
	Frequency of operation	—	FB_CLK	MHz	
FB1	Clock period	1/FB_CLK	—	ns	
FB2	Address, data, and control output valid	—	13.5	ns	1
FB3	Address, data, and control output hold	0	—	ns	1
FB4	Data and $\overline{\text{FB\_TA}}$ input setup	15.5	—	ns	2
FB5	Data and $\overline{\text{FB\_TA}}$ input hold	0.5	—	ns	2

1. Specification is valid for all FB\_AD[31:0],  $\overline{\text{FB\_BE/BWE}n}$ ,  $\overline{\text{FB\_CS}n}$ , FB\_OE, FB\_R/W, FB\_TBST, FB\_TSIZ[1:0], FB\_ALE, and FB\_TS.
2. Specification is valid for all FB\_AD[31:0] and  $\overline{\text{FB\_TA}}$ .

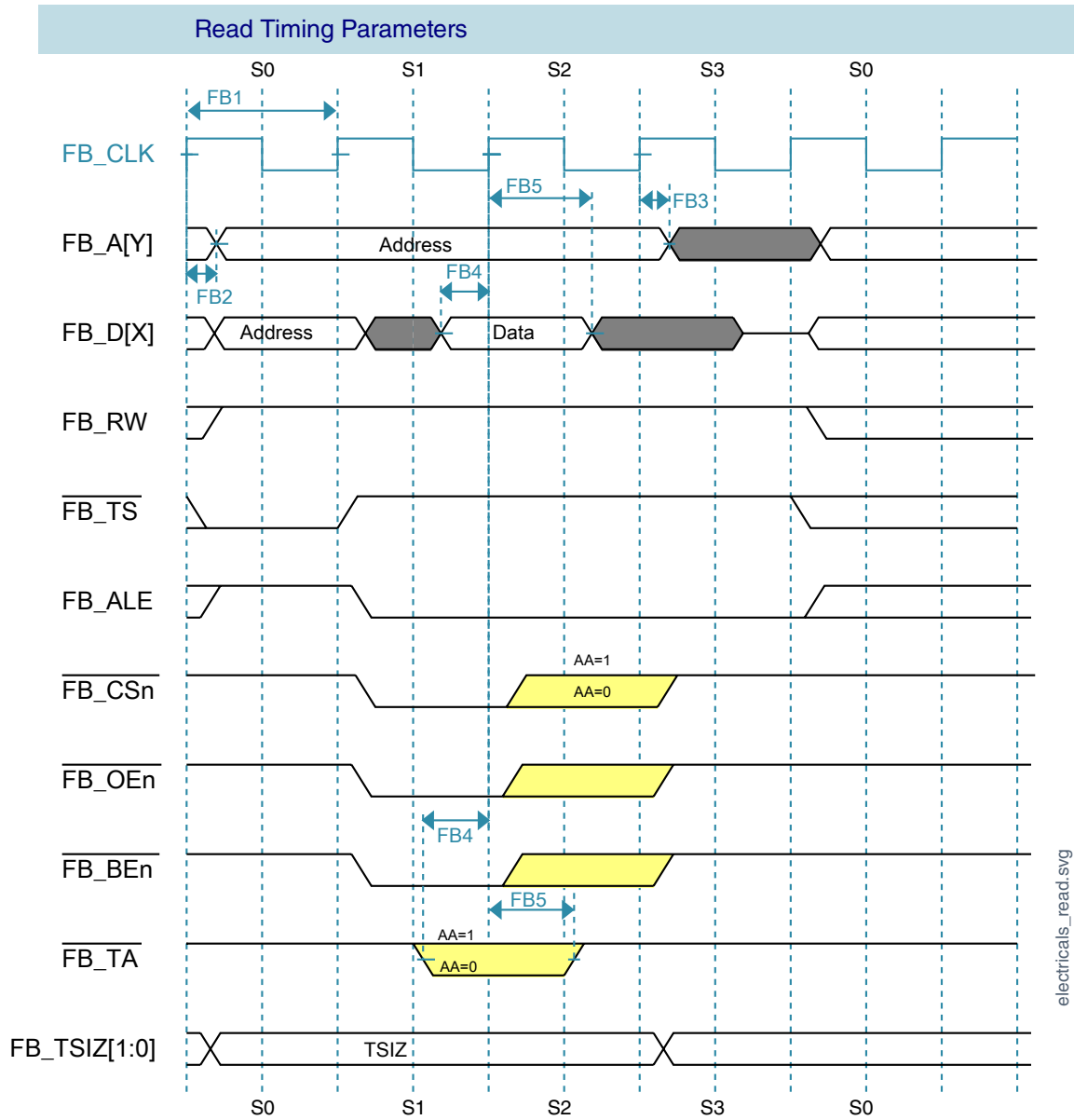
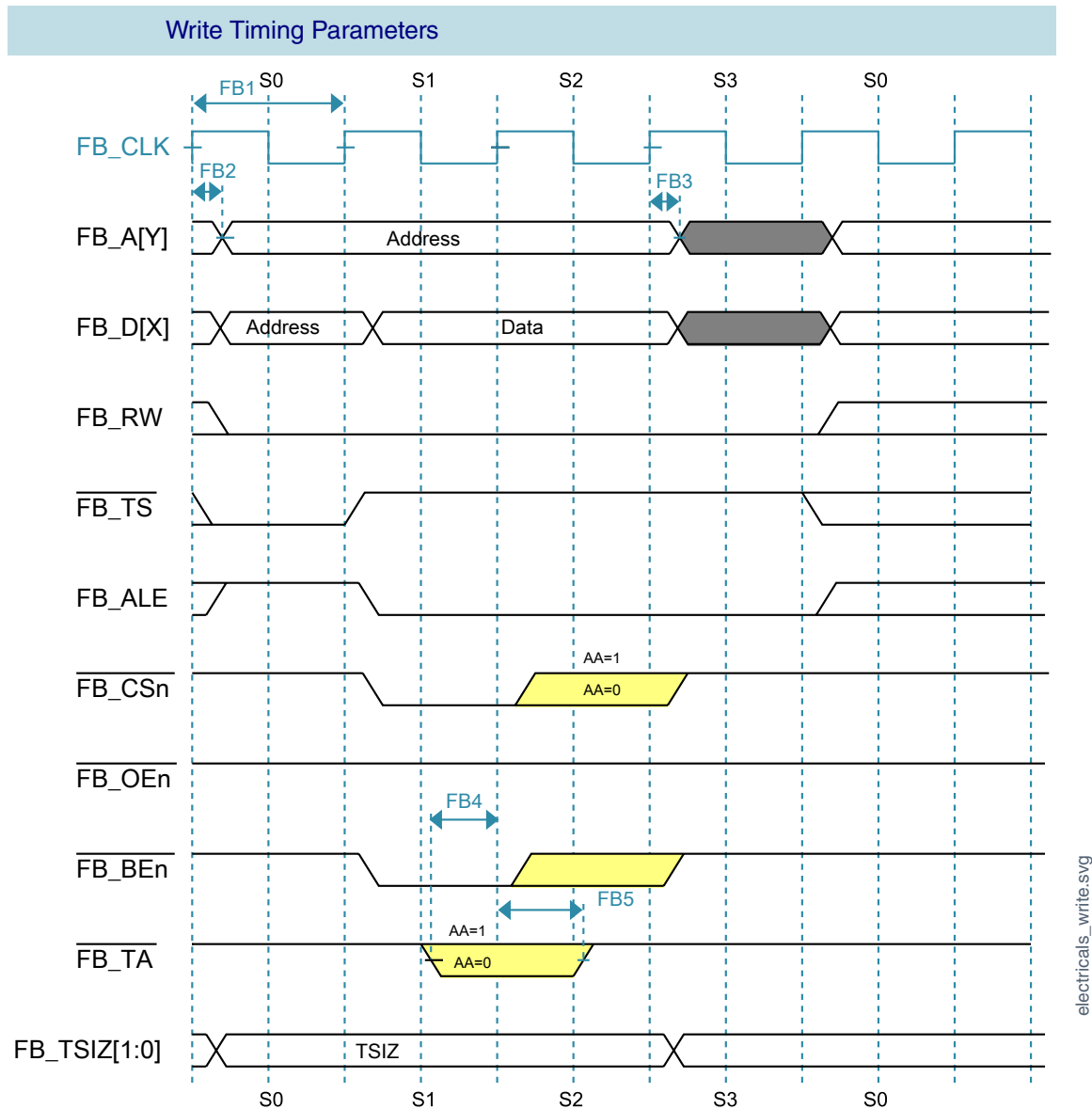

Figure 13. FlexBus read timing diagram

electricals\_read.svg



**Figure 14. FlexBus write timing diagram**

### 3.5 Security and integrity modules

There are no specifications necessary for the device's security and integrity modules.

### 3.6 Analog

### 3.6.1 ADC electrical specifications

The 16-bit accuracy specifications listed in [Table 30](#) and [Table 31](#) are achievable on the differential pins ADCx\_DP0, ADCx\_DM0.

All other ADC channels meet the 13-bit differential/12-bit single-ended accuracy specifications.

#### 3.6.1.1 16-bit ADC operating conditions

**Table 30. 16-bit ADC operating conditions**

Symbol	Description	Conditions	Min.	Typ. <sup>1</sup>	Max.	Unit	Notes
V <sub>DDA</sub>	Supply voltage	Absolute	1.71	—	3.6	V	
ΔV <sub>DDA</sub>	Supply voltage	Delta to V <sub>DD</sub> (V <sub>DD</sub> – V <sub>DDA</sub> )	-100	0	+100	mV	<a href="#">2</a>
ΔV <sub>SSA</sub>	Ground voltage	Delta to V <sub>SS</sub> (V <sub>SS</sub> – V <sub>SSA</sub> )	-100	0	+100	mV	<a href="#">2</a>
V <sub>REFH</sub>	ADC reference voltage high		1.13	V <sub>DDA</sub>	V <sub>DDA</sub>	V	
V <sub>REFL</sub>	ADC reference voltage low		V <sub>SSA</sub>	V <sub>SSA</sub>	V <sub>SSA</sub>	V	
V <sub>ADIN</sub>	Input voltage		V <sub>REFL</sub>	—	V <sub>REFH</sub>	V	
C <sub>ADIN</sub>	Input capacitance	<ul style="list-style-type: none"> <li>16-bit mode</li> <li>8-bit / 10-bit / 12-bit modes</li> </ul>	—	8	10	pF	
R <sub>ADIN</sub>	Input series resistance		—	2	5	kΩ	
R <sub>AS</sub>	Analog source resistance (external)	13-bit / 12-bit modes f <sub>ADCK</sub> < 4 MHz	—	—	5	kΩ	<a href="#">3</a>
f <sub>ADCK</sub>	ADC conversion clock frequency	≤ 13-bit mode	1.0	—	18.0	MHz	<a href="#">4</a>
f <sub>ADCK</sub>	ADC conversion clock frequency	16-bit mode	2.0	—	12.0	MHz	<a href="#">4</a>
C <sub>rate</sub>	ADC conversion rate	≤ 13-bit modes No ADC hardware averaging Continuous conversions enabled, subsequent conversion time	20.000	—	818.330	ksp/s	<a href="#">5</a>
C <sub>rate</sub>	ADC conversion rate	16-bit mode No ADC hardware averaging Continuous conversions enabled, subsequent conversion time	37.037	—	461.467	ksp/s	<a href="#">5</a>



1. Typical values assume  $V_{DDA} = 3.0\text{ V}$ ,  $\text{Temp} = 25\text{ }^\circ\text{C}$ ,  $f_{ADCK} = 1.0\text{ MHz}$ , unless otherwise stated. Typical values are for reference only, and are not tested in production.
2. DC potential difference.
3. This resistance is external to MCU. To achieve the best results, the analog source resistance must be kept as low as possible. The results in this data sheet were derived from a system that had  $< 8\ \Omega$  analog source resistance. The  $R_{AS}/C_{AS}$  time constant should be kept to  $< 1\text{ ns}$ .
4. To use the maximum ADC conversion clock frequency,  $\text{CFG2}[\text{ADHSC}]$  must be set and  $\text{CFG1}[\text{ADLPC}]$  must be clear.
5. For guidelines and examples of conversion rate calculation, download the [ADC calculator tool](#).

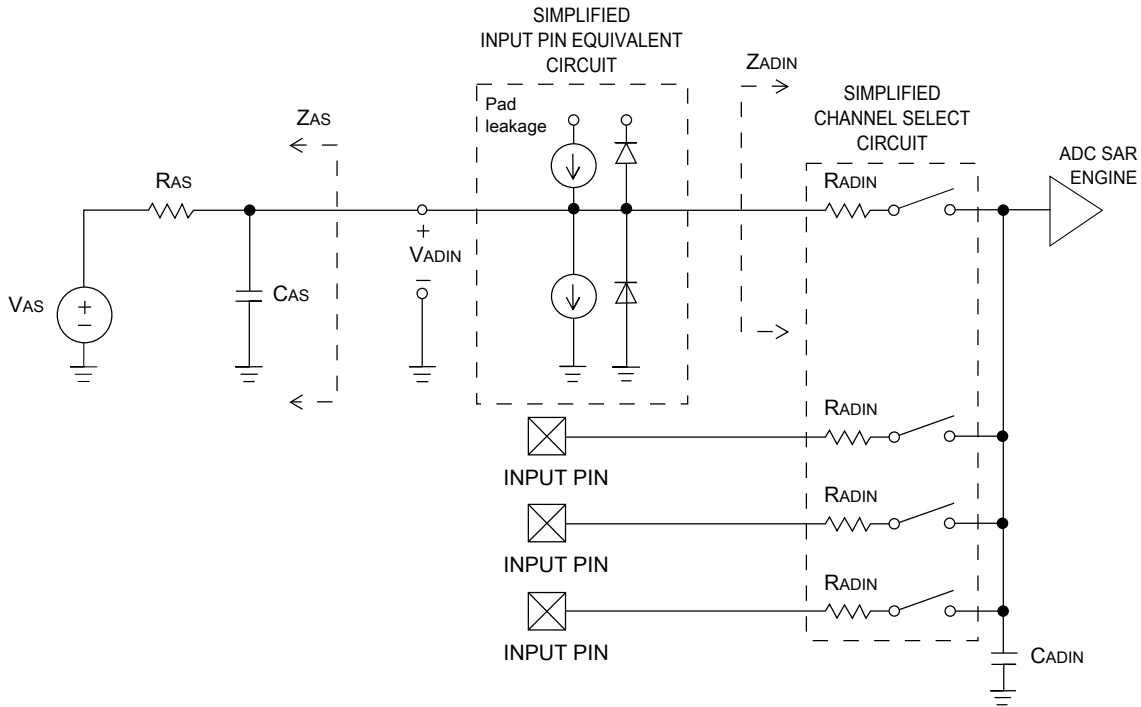

Figure 15. ADC input impedance equivalency diagram

### 3.6.1.2 16-bit ADC electrical characteristics

Table 31. 16-bit ADC characteristics ( $V_{REFH} = V_{DDA}$ ,  $V_{REFL} = V_{SSA}$ )

Symbol	Description	Conditions <sup>1</sup>	Min.	Typ. <sup>2</sup>	Max.	Unit	Notes
$I_{DDA\_ADC}$	Supply current		0.215	—	1.7	mA	3
$f_{ADACK}$	ADC asynchronous clock source	• $\text{ADLPC} = 1, \text{ADHSC} = 0$	1.2	2.4	3.9	MHz	$t_{ADACK} = 1/f_{ADACK}$
		• $\text{ADLPC} = 1, \text{ADHSC} = 1$	2.4	4.0	6.1	MHz	
		• $\text{ADLPC} = 0, \text{ADHSC} = 0$	3.0	5.2	7.3	MHz	
		• $\text{ADLPC} = 0, \text{ADHSC} = 1$	4.4	6.2	9.5	MHz	
	Sample Time	See Reference Manual chapter for sample times					

Table continues on the next page...

**Table 31. 16-bit ADC characteristics ( $V_{REFH} = V_{DDA}$ ,  $V_{REFL} = V_{SSA}$ ) (continued)**

Symbol	Description	Conditions <sup>1</sup>	Min.	Typ. <sup>2</sup>	Max.	Unit	Notes
TUE	Total unadjusted error	<ul style="list-style-type: none"> <li>12-bit modes</li> <li>&lt;12-bit modes</li> </ul>	—	±4	±6.8	LSB <sup>4</sup>	5
			—	±1.4	±2.1		
DNL	Differential non-linearity	<ul style="list-style-type: none"> <li>12-bit modes</li> <li>&lt;12-bit modes</li> </ul>	—	±0.7	-1.1 to +1.9	LSB <sup>4</sup>	5
			—	±0.2	-0.3 to 0.5		
INL	Integral non-linearity	<ul style="list-style-type: none"> <li>12-bit modes</li> <li>&lt;12-bit modes</li> </ul>	—	±1.0	-2.7 to +1.9	LSB <sup>4</sup>	5
			—	±0.5	-0.7 to +0.5		
E <sub>FS</sub>	Full-scale error	<ul style="list-style-type: none"> <li>12-bit modes</li> <li>&lt;12-bit modes</li> </ul>	—	-4	-5.4	LSB <sup>4</sup>	V <sub>ADIN</sub> = V <sub>DDA</sub> <sup>5</sup>
			—	-1.4	-1.8		
E <sub>Q</sub>	Quantization error	<ul style="list-style-type: none"> <li>16-bit modes</li> <li>≤13-bit modes</li> </ul>	—	-1 to 0	—	LSB <sup>4</sup>	
			—	—	±0.5		
ENOB	Effective number of bits	16-bit differential mode <ul style="list-style-type: none"> <li>Avg = 32</li> <li>Avg = 4</li> </ul>	12.8	14.5	—	bits	6
			11.9	13.8	—	bits	
		16-bit single-ended mode <ul style="list-style-type: none"> <li>Avg = 32</li> <li>Avg = 4</li> </ul>	12.2	13.9	—	bits	
			11.4	13.1	—	bits	
SINAD	Signal-to-noise plus distortion	See ENOB	6.02 × ENOB + 1.76			dB	
THD	Total harmonic distortion	16-bit differential mode <ul style="list-style-type: none"> <li>Avg = 32</li> </ul>	—	-94	—	dB	7
		16-bit single-ended mode <ul style="list-style-type: none"> <li>Avg = 32</li> </ul>	—	-85	—	dB	
SFDR	Spurious free dynamic range	16-bit differential mode <ul style="list-style-type: none"> <li>Avg = 32</li> </ul>	82	95	—	dB	7
		16-bit single-ended mode <ul style="list-style-type: none"> <li>Avg = 32</li> </ul>	78	90	—	dB	
E <sub>IL</sub>	Input leakage error		I <sub>in</sub> × R <sub>AS</sub>			mV	I <sub>in</sub> = leakage current (refer to the MCU's voltage and

Table continues on the next page...

**Table 31. 16-bit ADC characteristics ( $V_{REFH} = V_{DDA}$ ,  $V_{REFL} = V_{SSA}$ ) (continued)**

Symbol	Description	Conditions <sup>1</sup>	Min.	Typ. <sup>2</sup>	Max.	Unit	Notes
							current operating ratings)
	Temp sensor slope	Across the full temperature range of the device	1.55	1.62	1.69	mV/°C	8
$V_{TEMP25}$	Temp sensor voltage	25 °C	706	716	726	mV	8

1. All accuracy numbers assume the ADC is calibrated with  $V_{REFH} = V_{DDA}$
2. Typical values assume  $V_{DDA} = 3.0$  V, Temp = 25 °C,  $f_{ADCK} = 2.0$  MHz unless otherwise stated. Typical values are for reference only and are not tested in production.
3. The ADC supply current depends on the ADC conversion clock speed, conversion rate and ADC\_CFG1[ADLPC] (low power). For lowest power operation, ADC\_CFG1[ADLPC] must be set, the ADC\_CFG2[ADHSC] bit must be clear with 1 MHz ADC conversion clock speed.
4. 1 LSB =  $(V_{REFH} - V_{REFL})/2^N$
5. ADC conversion clock < 16 MHz, Max hardware averaging (AVGE = %1, AVGS = %11)
6. Input data is 100 Hz sine wave. ADC conversion clock < 12 MHz.
7. Input data is 1 kHz sine wave. ADC conversion clock < 12 MHz.
8. ADC conversion clock < 3 MHz

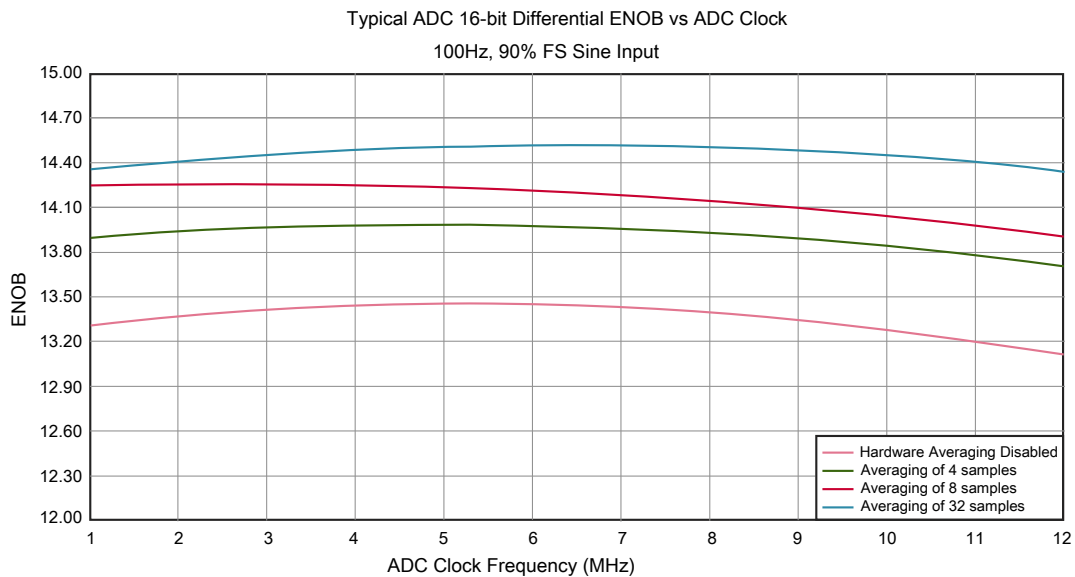
**Figure 16. Typical ENOB vs. ADC\_CLK for 16-bit differential mode**

## Peripheral operating requirements and behaviors

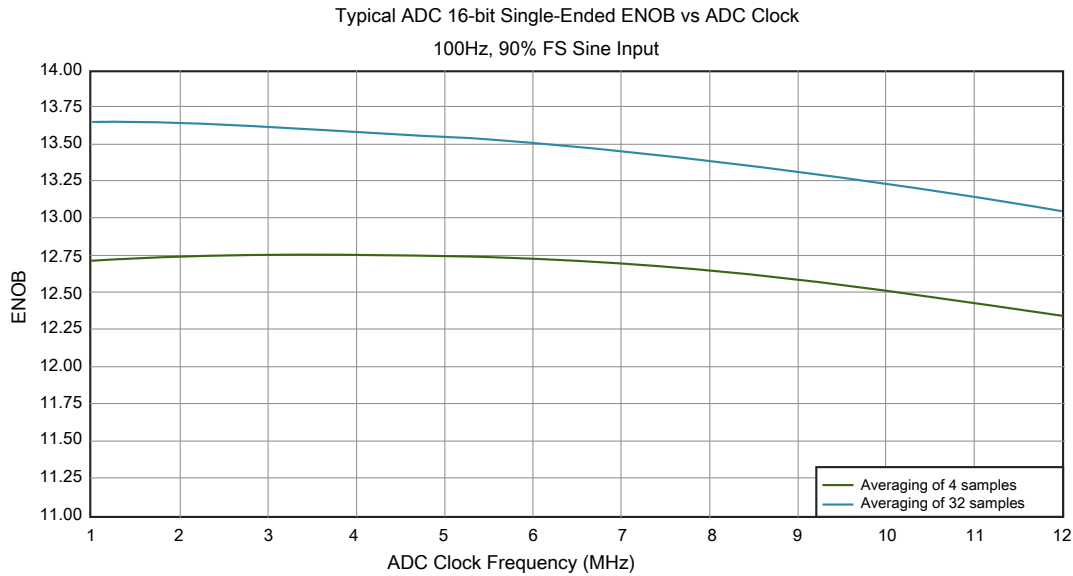

**Figure 17. Typical ENOB vs. ADC\_CLK for 16-bit single-ended mode**

### 3.6.2 CMP and 6-bit DAC electrical specifications

**Table 32. Comparator and 6-bit DAC electrical specifications**

Symbol	Description	Min.	Typ.	Max.	Unit
$V_{DD}$	Supply voltage	1.71	—	3.6	V
$I_{DDHS}$	Supply current, High-speed mode (EN=1, PMODE=1)	—	—	200	$\mu$ A
$I_{DDL S}$	Supply current, low-speed mode (EN=1, PMODE=0)	—	—	20	$\mu$ A
$V_{AIN}$	Analog input voltage	$V_{SS} - 0.3$	—	$V_{DD}$	V
$V_{AIO}$	Analog input offset voltage	—	—	20	mV
$V_H$	Analog comparator hysteresis <sup>1</sup>				
	• CR0[HYSTCTR] = 00	—	5	—	mV
	• CR0[HYSTCTR] = 01	—	10	—	mV
	• CR0[HYSTCTR] = 10	—	20	—	mV
	• CR0[HYSTCTR] = 11	—	30	—	mV
$V_{CMPOh}$	Output high	$V_{DD} - 0.5$	—	—	V
$V_{CMPOl}$	Output low	—	—	0.5	V
$t_{DHS}$	Propagation delay, high-speed mode (EN=1, PMODE=1)	20	50	200	ns
$t_{DLS}$	Propagation delay, low-speed mode (EN=1, PMODE=0)	80	250	600	ns
	Analog comparator initialization delay <sup>2</sup>	—	—	40	$\mu$ s
$I_{DAC6b}$	6-bit DAC current adder (enabled)	—	7	—	$\mu$ A
INL	6-bit DAC integral non-linearity	-0.5	—	0.5	LSB <sup>3</sup>
DNL	6-bit DAC differential non-linearity	-0.3	—	0.3	LSB

1. Typical hysteresis is measured with input voltage range limited to 0.6 to  $V_{DD}-0.6$  V.
2. Comparator initialization delay is defined as the time between software writes to change control inputs (Writes to CMP\_DACCR[DACEN], CMP\_DACCR[VRSEL], CMP\_DACCR[VOSEL], CMP\_MUXCR[PSEL], and CMP\_MUXCR[MSEL]) and the comparator output settling to a stable level.
3.  $1 \text{ LSB} = V_{\text{reference}}/64$

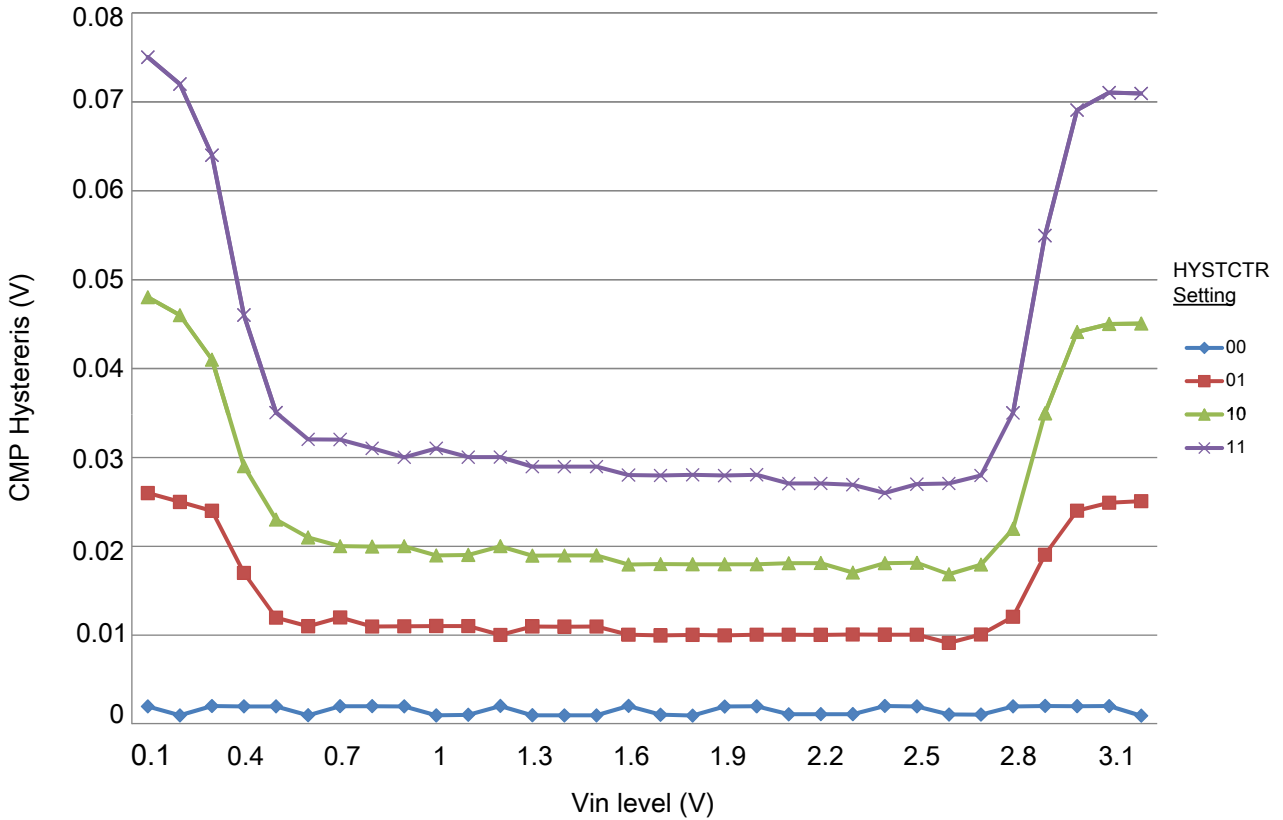

Figure 18. Typical hysteresis vs. Vin level (VDD = 3.3 V, PMODE = 0)

## Peripheral operating requirements and behaviors

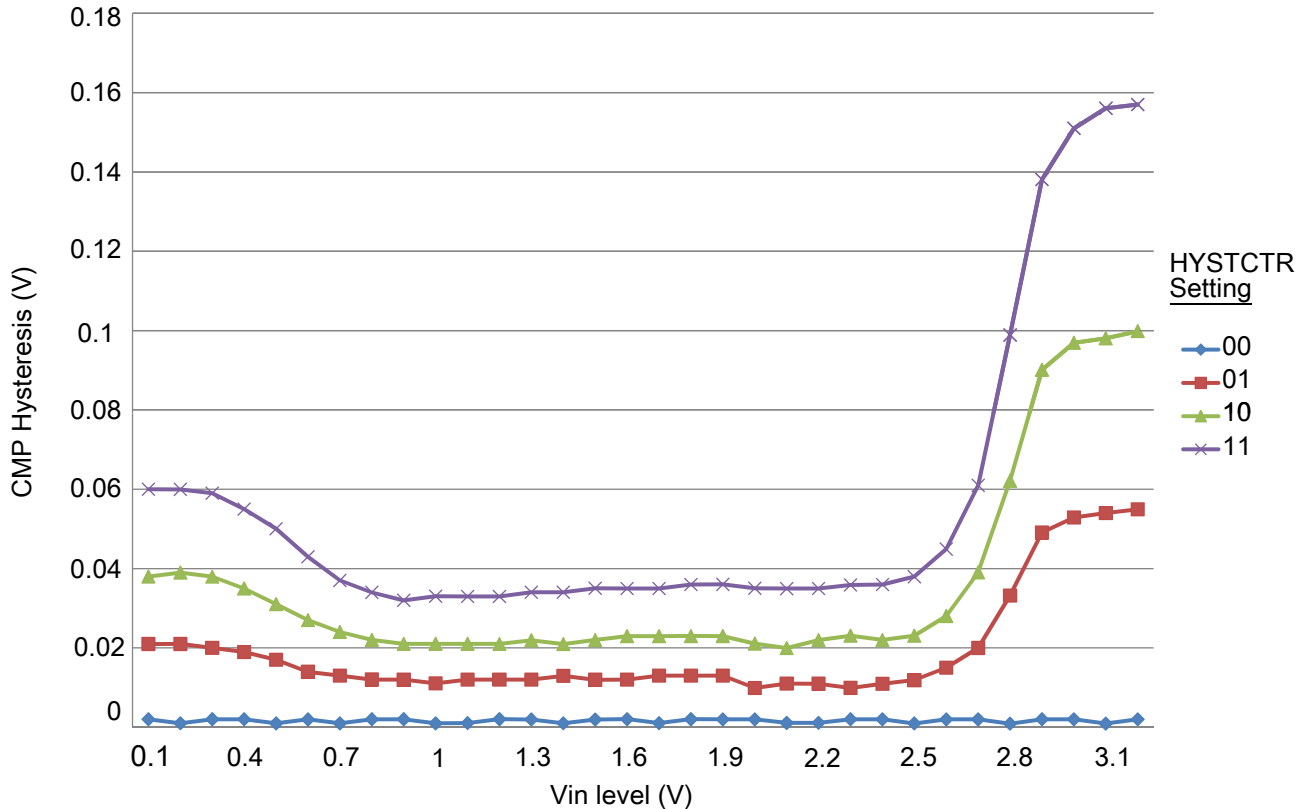

Figure 19. Typical hysteresis vs. Vin level (VDD = 3.3 V, PMODE = 1)

### 3.6.3 12-bit DAC electrical characteristics

#### 3.6.3.1 12-bit DAC operating requirements

Table 33. 12-bit DAC operating requirements

Symbol	Description	Min.	Max.	Unit	Notes
$V_{DDA}$	Supply voltage	1.71	3.6	V	
$V_{DACR}$	Reference voltage	1.13	3.6	V	1
$C_L$	Output load capacitance	—	100	pF	2
$I_L$	Output load current	—	1	mA	

1. The DAC reference can be selected to be  $V_{DDA}$  or  $V_{REFH}$ .
2. A small load capacitance (47 pF) can improve the bandwidth performance of the DAC.

### 3.6.3.2 12-bit DAC operating behaviors

Table 34. 12-bit DAC operating behaviors

Symbol	Description	Min.	Typ.	Max.	Unit	Notes
$I_{DDA\_DACLP}$	Supply current — low-power mode	—	—	150	$\mu\text{A}$	
$I_{DDA\_DACHP}$	Supply current — high-speed mode	—	—	700	$\mu\text{A}$	
$t_{DACLP}$	Full-scale settling time (0x080 to 0xF7F) — low-power mode	—	100	200	$\mu\text{s}$	1
$t_{DACHP}$	Full-scale settling time (0x080 to 0xF7F) — high-power mode	—	15	30	$\mu\text{s}$	1
$t_{CCDACLP}$	Code-to-code settling time (0xBF8 to 0xC08) — low-power mode and high-speed mode	—	0.7	1	$\mu\text{s}$	1
$V_{dacoutl}$	DAC output voltage range low — high-speed mode, no load, DAC set to 0x000	—	—	100	mV	
$V_{dacouth}$	DAC output voltage range high — high-speed mode, no load, DAC set to 0xFFFF	$V_{DACR} - 100$	—	$V_{DACR}$	mV	
INL	Integral non-linearity error — high speed mode	—	—	$\pm 8$	LSB	2
DNL	Differential non-linearity error — $V_{DACR} > 2\text{ V}$	—	—	$\pm 1$	LSB	3
DNL	Differential non-linearity error — $V_{DACR} = V_{REF\_OUT}$	—	—	$\pm 1$	LSB	4
$V_{OFFSET}$	Offset error	—	$\pm 0.4$	$\pm 0.8$	%FSR	5
$E_G$	Gain error	—	$\pm 0.1$	$\pm 0.6$	%FSR	5
PSRR	Power supply rejection ratio, $V_{DDA} \geq 2.4\text{ V}$	60	—	90	dB	
$T_{CO}$	Temperature coefficient offset voltage	—	3.7	—	$\mu\text{V}/\text{C}$	6
$T_{GE}$	Temperature coefficient gain error	—	0.000421	—	%FSR/C	
$A_C$	Offset aging coefficient	—	—	100	$\mu\text{V}/\text{yr}$	
$R_{op}$	Output resistance (load = 3 k $\Omega$ )	—	—	250	$\Omega$	
SR	Slew rate -80h $\rightarrow$ F7Fh $\rightarrow$ 80h <ul style="list-style-type: none"> <li>• High power (SP<sub>HP</sub>)</li> <li>• Low power (SP<sub>LP</sub>)</li> </ul>	1.2 0.05	1.7 0.12	— —	V/ $\mu\text{s}$	
CT	Channel to channel cross talk	—	—	-80	dB	
BW	3dB bandwidth <ul style="list-style-type: none"> <li>• High power (SP<sub>HP</sub>)</li> <li>• Low power (SP<sub>LP</sub>)</li> </ul>	550 40	— —	— —	kHz	

1. Settling within  $\pm 1$  LSB
2. The INL is measured for 0 + 100 mV to  $V_{DACR} - 100\text{ mV}$
3. The DNL is measured for 0 + 100 mV to  $V_{DACR} - 100\text{ mV}$
4. The DNL is measured for 0 + 100 mV to  $V_{DACR} - 100\text{ mV}$  with  $V_{DDA} > 2.4\text{ V}$
5. Calculated by a best fit curve from  $V_{SS} + 100\text{ mV}$  to  $V_{DACR} - 100\text{ mV}$

## Peripheral operating requirements and behaviors

- $V_{DDA} = 3.0\text{ V}$ , reference select set for  $V_{DDA}$  (DACx\_CO:DACRFS = 1), high power mode (DACx\_C0:LPEN = 0), DAC set to 0x800, temperature range is across the full range of the device

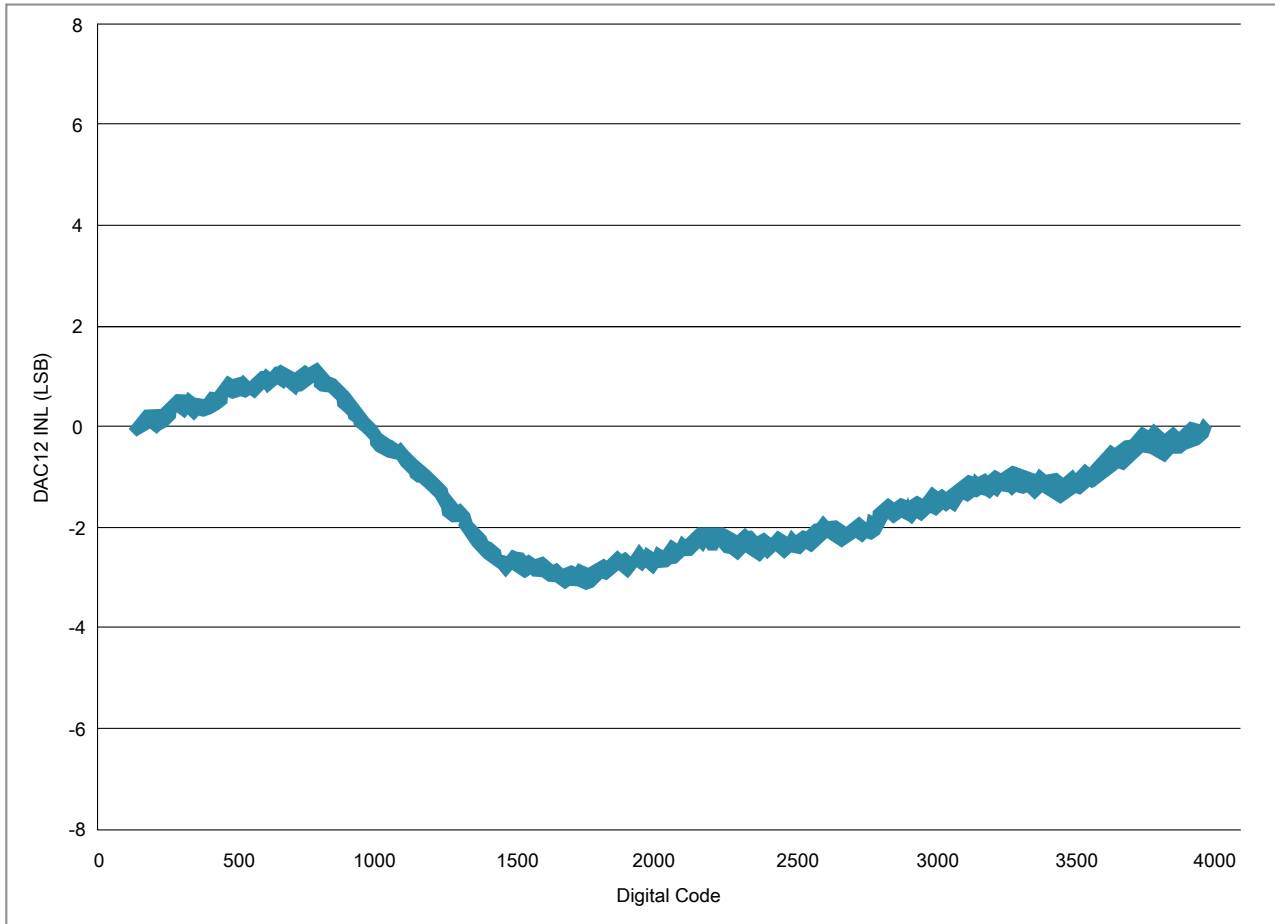

**Figure 20. Typical INL error vs. digital code**



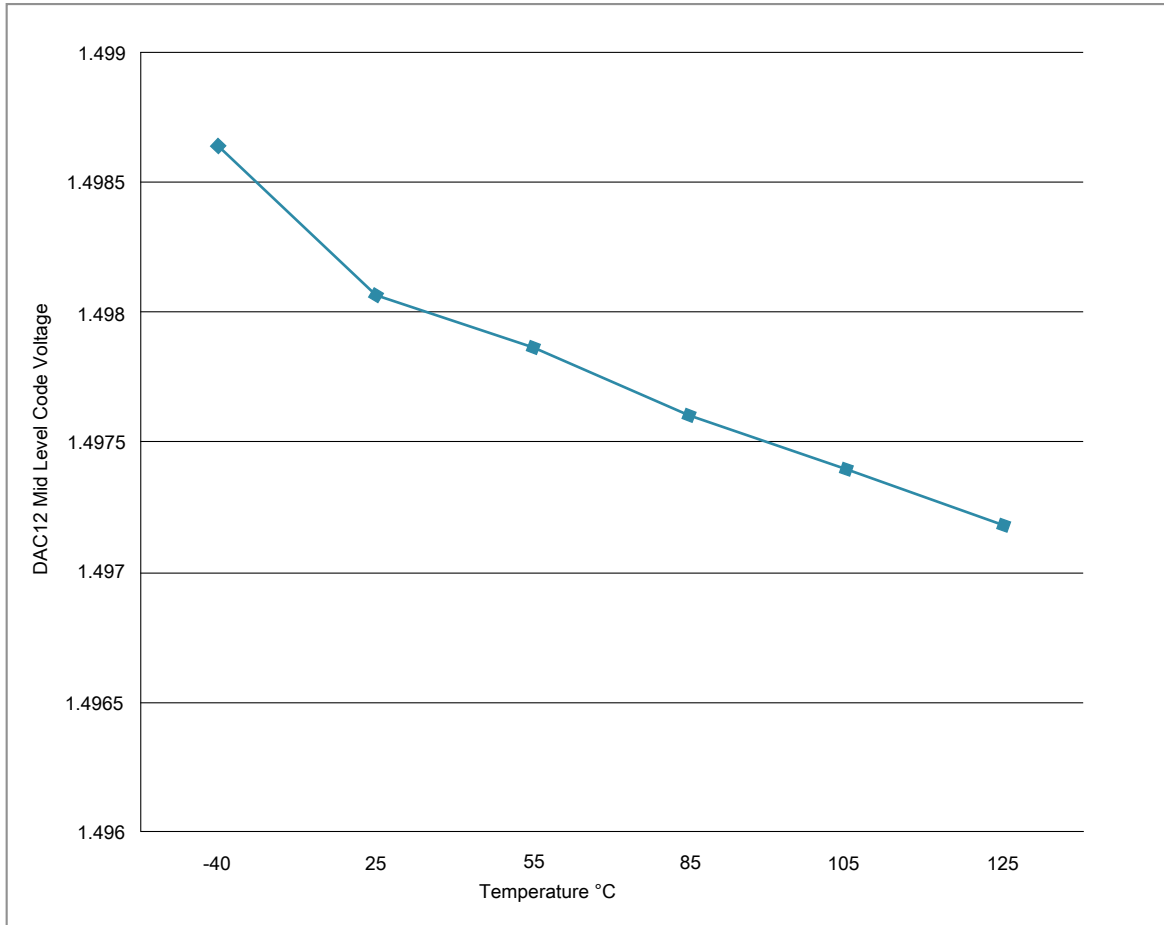

Figure 21. Offset at half scale vs. temperature

### 3.6.4 Voltage reference electrical specifications

Table 35. VREF full-range operating requirements

Symbol	Description	Min.	Max.	Unit	Notes
$V_{DDA}$	Supply voltage	1.71	3.6	V	—
$T_A$	Temperature	Operating temperature range of the device		°C	—
$C_L$	Output load capacitance	100		nF	1, 2

- $C_L$  must be connected to VREF\_OUT if the VREF\_OUT functionality is being used for either an internal or external reference.
- The load capacitance should not exceed +/-25% of the nominal specified  $C_L$  value over the operating temperature range of the device.

**Table 36. VREF full-range operating behaviors**

Symbol	Description	Min.	Typ.	Max.	Unit	Notes
$V_{out}$	Voltage reference output with factory trim at nominal $V_{DDA}$ and temperature= 25 °C	1.192	1.195	1.198	V	1
$V_{out}$	Voltage reference output with user trim at nominal $V_{DDA}$ and temperature= 25 °C	1.1945	1.195	1.1955	V	1
$V_{step}$	Voltage reference trim step	—	0.5	—	mV	1
$V_{tdrift}$	Temperature drift ( $V_{max} - V_{min}$ across the full temperature range)	—	2	15	mV	1
$I_{bg}$	Bandgap only current	—	60	80	$\mu$ A	1
$I_{lp}$	Low-power buffer current	—	180	360	$\mu$ A	1
$I_{hp}$	High-power buffer current	—	480	960	mA	1
$\Delta V_{LOAD}$	Load regulation • current = $\pm 1.0$ mA	—	200	—	$\mu$ V	1, 2
$T_{stup}$	Buffer startup time	—	—	100	$\mu$ s	—
$T_{chop\_osc\_st\ up}$	Internal bandgap start-up delay with chop oscillator enabled	—	—	35	ms	—
$V_{vdrift}$	Voltage drift ( $V_{max} - V_{min}$ across the full voltage range)	—	0.5	2	mV	1

1. See the chip's Reference Manual for the appropriate settings of the VREF Status and Control register.
2. Load regulation voltage is the difference between the VREF\_OUT voltage with no load vs. voltage with defined load

**Table 37. VREF limited-range operating requirements**

Symbol	Description	Min.	Max.	Unit	Notes
$T_A$	Temperature	0	50	°C	—

**Table 38. VREF limited-range operating behaviors**

Symbol	Description	Min.	Max.	Unit	Notes
$V_{out}$	Voltage reference output with factory trim	1.173	1.225	V	—

## 3.7 Timers

See [General switching specifications](#).

## 3.8 Communication interfaces

### 3.8.1 Ethernet switching specifications

The following timing specs are defined at the chip I/O pin and must be translated appropriately to arrive at timing specs/constraints for the physical interface.

#### 3.8.1.1 MII signal switching specifications

The following timing specs meet the requirements for MII style interfaces for a range of transceiver devices.

**Table 39. MII signal switching specifications**

Symbol	Description	Min.	Max.	Unit
—	RXCLK frequency	—	25	MHz
MII1	RXCLK pulse width high	35%	65%	RXCLK period
MII2	RXCLK pulse width low	35%	65%	RXCLK period
MII3	RXD[3:0], RXDV, RXER to RXCLK setup	5	—	ns
MII4	RXCLK to RXD[3:0], RXDV, RXER hold	5	—	ns
—	TXCLK frequency	—	25	MHz
MII5	TXCLK pulse width high	35%	65%	TXCLK period
MII6	TXCLK pulse width low	35%	65%	TXCLK period
MII7	TXCLK to TXD[3:0], TXEN, TXER invalid	2	—	ns
MII8	TXCLK to TXD[3:0], TXEN, TXER valid	—	25	ns

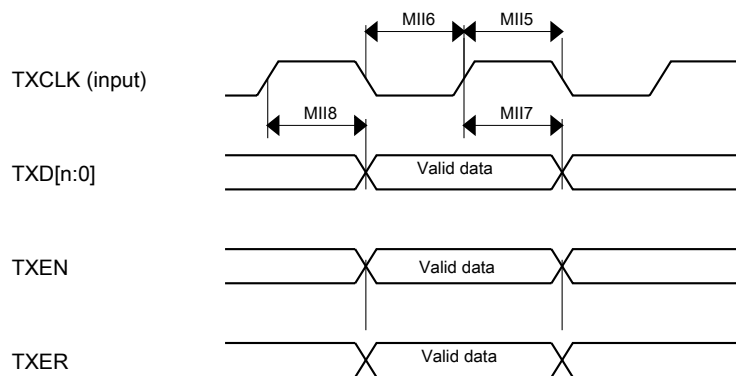

**Figure 22. RMI/MII transmit signal timing diagram**

## Peripheral operating requirements and behaviors

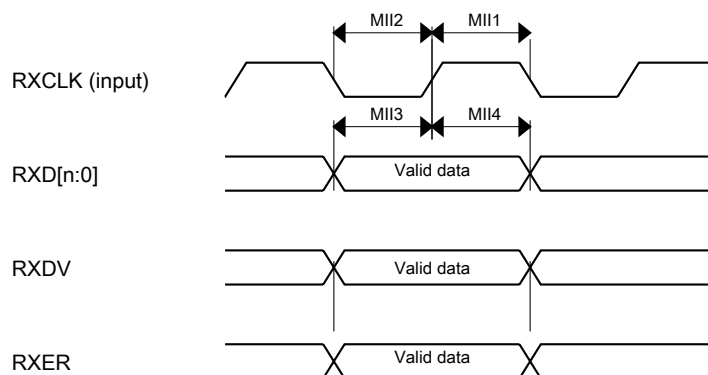

**Figure 23. RMIIMII receive signal timing diagram**

### 3.8.1.2 RMIIMII signal switching specifications

The following timing specs meet the requirements for RMIIMII style interfaces for a range of transceiver devices.

**Table 40. RMIIMII signal switching specifications**

Num	Description	Min.	Max.	Unit
—	EXTAL frequency (RMIIMII input clock RMIIMII_CLK)	—	50	MHz
RMIIMII1	RMIIMII_CLK pulse width high	35%	65%	RMIIMII_CLK period
RMIIMII2	RMIIMII_CLK pulse width low	35%	65%	RMIIMII_CLK period
RMIIMII3	RXD[1:0], CRS_DV, RXER to RMIIMII_CLK setup	4	—	ns
RMIIMII4	RMIIMII_CLK to RXD[1:0], CRS_DV, RXER hold	2	—	ns
RMIIMII7	RMIIMII_CLK to TXD[1:0], TXEN invalid	4	—	ns
RMIIMII8	RMIIMII_CLK to TXD[1:0], TXEN valid	—	15	ns

### 3.8.1.3 MDIO serial management timing specifications

**Table 41. MDIO serial management channel signal timing**

Num	Characteristic	Symbol	Min	Max	Unit
E10	MDC cycle time	$t_{MDC}$	400	—	ns
E11	MDC pulse width		40	60	% $t_{MDC}$
E12	MDC to MDIO output valid		—	375	ns
E13	MDC to MDIO output invalid		25	—	ns
E14	MDIO input to MDC setup		10	—	ns
E15	MDIO input to MDC hold		0	—	ns

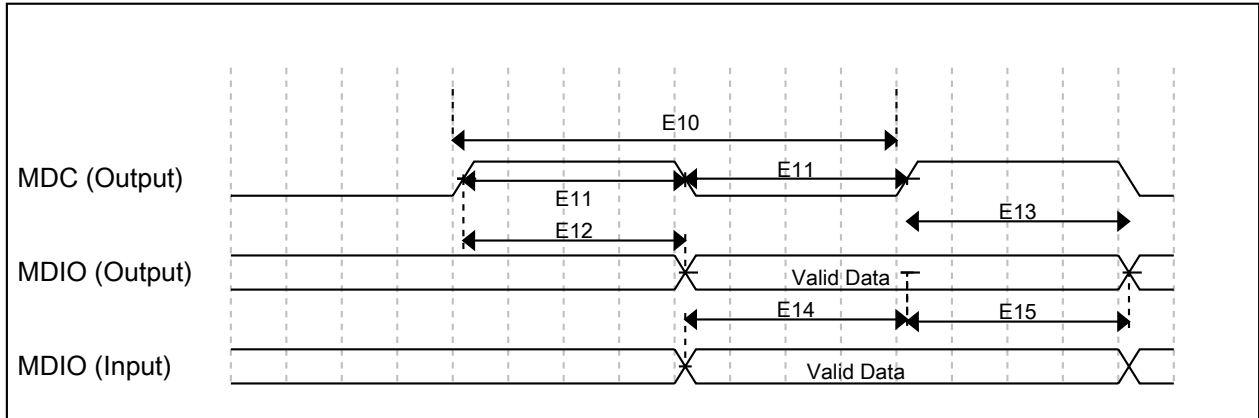

Figure 24. MDIO serial management channel timing diagram

### 3.8.2 USB electrical specifications

The USB electricals for the USB On-the-Go module conform to the standards documented by the Universal Serial Bus Implementers Forum. For the most up-to-date standards, visit [usb.org](http://usb.org).

#### NOTE

The MCGPLLCLK meets the USB jitter and signaling rate specifications for certification with the use of an external clock/crystal for both Device and Host modes.

The MCGFLLCLK does not meet the USB jitter or signaling rate specifications for certification.

The IRC48M meets the USB jitter and signaling rate specifications for certification in Device mode when the USB clock recovery mode is enabled. It does not meet the USB signaling rate specifications for certification in Host mode operation.

### 3.8.3 USB DCD electrical specifications

Table 42. USB0 DCD electrical specifications

Symbol	Description	Min.	Typ.	Max.	Unit
V <sub>DP_SRC</sub>	USB_DP source voltage (up to 250 $\mu$ A)	0.5	—	0.7	V
V <sub>LGC</sub>	Threshold voltage for logic high	0.8	—	2.0	V

Table continues on the next page...

**Table 42. USB0 DCD electrical specifications (continued)**

Symbol	Description	Min.	Typ.	Max.	Unit
I <sub>DP_SRC</sub>	USB_DP source current	7	10	13	μA
I <sub>DM_SINK</sub>	USB_DM sink current	50	100	150	μA
R <sub>DM_DWN</sub>	D- pulldown resistance for data pin contact detect	14.25	—	24.8	kΩ
V <sub>DAT_REF</sub>	Data detect voltage	0.25	0.33	0.4	V

### 3.8.4 USB VREG electrical specifications

**Table 43. USB VREG electrical specifications**

Symbol	Description	Min.	Typ. <sup>1</sup>	Max.	Unit	Notes
V <sub>REGIN</sub>	Input supply voltage	2.7	—	5.5	V	
I <sub>DDon</sub>	Quiescent current — Run mode, load current equal zero, input supply (V <sub>REGIN</sub> ) > 3.6 V	—	125	186	μA	
I <sub>DDstby</sub>	Quiescent current — Standby mode, load current equal zero	—	1.1	10	μA	
I <sub>DDoff</sub>	Quiescent current — Shutdown mode <ul style="list-style-type: none"> <li>V<sub>REGIN</sub> = 5.0 V and temperature=25 °C</li> <li>Across operating voltage and temperature</li> </ul>	—	650	—	nA	
		—	—	4	μA	
I <sub>LOADrun</sub>	Maximum load current — Run mode	—	—	120	mA	
I <sub>LOADstby</sub>	Maximum load current — Standby mode	—	—	1	mA	
V <sub>Reg33out</sub>	Regulator output voltage — Input supply (V <sub>REGIN</sub> ) > 3.6 V <ul style="list-style-type: none"> <li>Run mode</li> <li>Standby mode</li> </ul>	3	3.3	3.6	V	
		2.1	2.8	3.6	V	
V <sub>Reg33out</sub>	Regulator output voltage — Input supply (V <sub>REGIN</sub> ) < 3.6 V, pass-through mode	2.1	—	3.6	V	2
C <sub>OUT</sub>	External output capacitor	1.76	2.2	8.16	μF	
ESR	External output capacitor equivalent series resistance	1	—	100	mΩ	
I <sub>LIM</sub>	Short circuit current	—	290	—	mA	

1. Typical values assume V<sub>REGIN</sub> = 5.0 V, Temp = 25 °C unless otherwise stated.

2. Operating in pass-through mode: regulator output voltage equal to the input voltage minus a drop proportional to I<sub>Load</sub>.

### 3.8.5 CAN switching specifications

See [General switching specifications](#).

### 3.8.6 DSPI switching specifications (limited voltage range)

The DMA Serial Peripheral Interface (DSPI) provides a synchronous serial bus with master and slave operations. Many of the transfer attributes are programmable. The tables below provide DSPI timing characteristics for classic SPI timing modes. Refer to the DSPI chapter of the Reference Manual for information on the modified transfer formats used for communicating with slower peripheral devices.

**Table 44. Master mode DSPI timing (limited voltage range)**

Num	Description	Min.	Max.	Unit	Notes
	Operating voltage	2.7	3.6	V	
	Frequency of operation	—	30	MHz	
DS1	DSPI_SCK output cycle time	$2 \times t_{\text{BUS}}$	—	ns	
DS2	DSPI_SCK output high/low time	$(t_{\text{SCK}}/2) - 2$	$(t_{\text{SCK}}/2) + 2$	ns	
DS3	DSPI_PCS <sub>n</sub> valid to DSPI_SCK delay	$(t_{\text{BUS}} \times 2) - 2$	—	ns	1
DS4	DSPI_SCK to DSPI_PCS <sub>n</sub> invalid delay	$(t_{\text{BUS}} \times 2) - 2$	—	ns	2
DS5	DSPI_SCK to DSPI_SOUT valid	—	8.5	ns	
DS6	DSPI_SCK to DSPI_SOUT invalid	-2	—	ns	
DS7	DSPI_SIN to DSPI_SCK input setup	15	—	ns	
DS8	DSPI_SCK to DSPI_SIN input hold	0	—	ns	

1. The delay is programmable in SPI<sub>x</sub>\_CTAR<sub>n</sub>[PSSCK] and SPI<sub>x</sub>\_CTAR<sub>n</sub>[CSSCK].
2. The delay is programmable in SPI<sub>x</sub>\_CTAR<sub>n</sub>[PASC] and SPI<sub>x</sub>\_CTAR<sub>n</sub>[ASC].

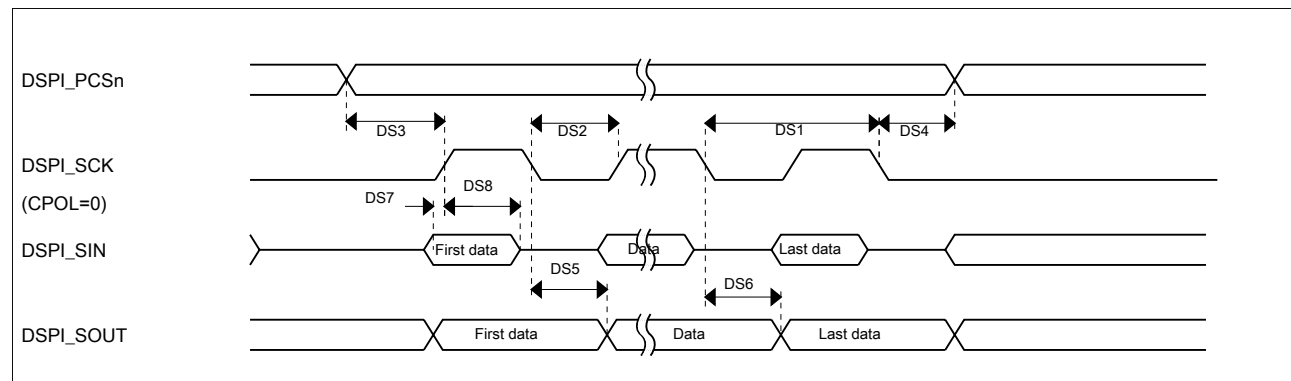
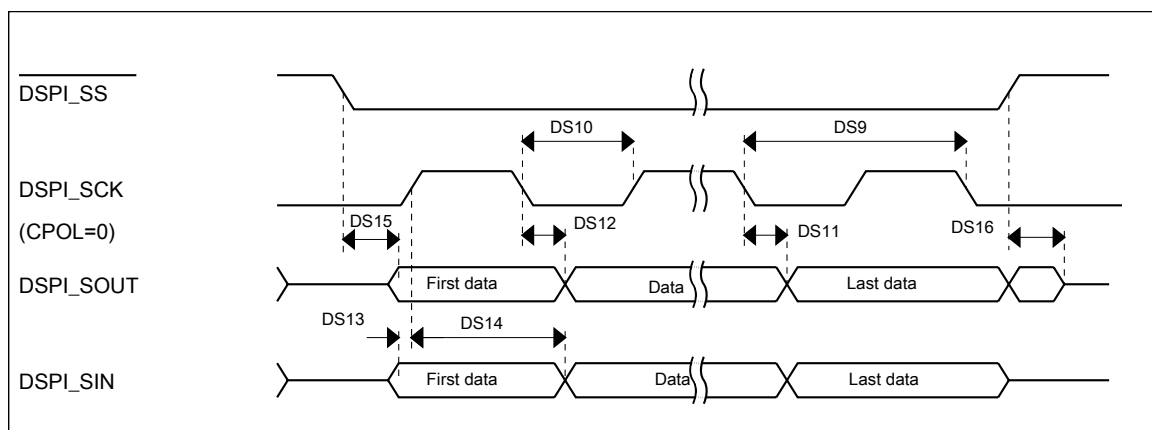

**Figure 25. DSPI classic SPI timing — master mode**

**Table 45. Slave mode DSPI timing (limited voltage range)**

Num	Description	Min.	Max.	Unit
	Operating voltage	2.7	3.6	V
	Frequency of operation		15 <sup>1</sup>	MHz
DS9	DSPI_SCK input cycle time	4 x t <sub>BUS</sub>	—	ns
DS10	DSPI_SCK input high/low time	(t <sub>SCK</sub> /2) - 2	(t <sub>SCK</sub> /2) + 2	ns
DS11	DSPI_SCK to DSPI_SOUT valid	—	10	ns
DS12	DSPI_SCK to DSPI_SOUT invalid	0	—	ns
DS13	DSPI_SIN to DSPI_SCK input setup	2	—	ns
DS14	DSPI_SCK to DSPI_SIN input hold	7	—	ns
DS15	DSPI_SS active to DSPI_SOUT driven	—	14	ns
DS16	DSPI_SS inactive to DSPI_SOUT not driven	—	14	ns

1. The maximum operating frequency is measured with non-continuous CS and SCK. When DSPI is configured with continuous CS and SCK, there is a constraint that SPI clock should not be greater than 1/6 of bus clock, for example, when bus clock is 60MHz, SPI clock should not be greater than 10MHz



**Figure 26. DSPI classic SPI timing — slave mode**



### 3.8.7 DSPI switching specifications (full voltage range)

The DMA Serial Peripheral Interface (DSPI) provides a synchronous serial bus with master and slave operations. Many of the transfer attributes are programmable. The tables below provides DSPI timing characteristics for classic SPI timing modes. Refer to the DSPI chapter of the Reference Manual for information on the modified transfer formats used for communicating with slower peripheral devices.

**Table 46. Master mode DSPI timing (full voltage range)**

Num	Description	Min.	Max.	Unit	Notes
	Operating voltage	1.71	3.6	V	1
	Frequency of operation	—	15	MHz	
DS1	DSPI_SCK output cycle time	$4 \times t_{\text{BUS}}$	—	ns	
DS2	DSPI_SCK output high/low time	$(t_{\text{SCK}/2}) - 4$	$(t_{\text{SCK}/2}) + 4$	ns	
DS3	DSPI_PCS $_n$ valid to DSPI_SCK delay	$(t_{\text{BUS}} \times 2) - 4$	—	ns	2
DS4	DSPI_SCK to DSPI_PCS $_n$ invalid delay	$(t_{\text{BUS}} \times 2) - 4$	—	ns	3
DS5	DSPI_SCK to DSPI_SOUT valid	—	10	ns	
DS6	DSPI_SCK to DSPI_SOUT invalid	-4.5	—	ns	
DS7	DSPI_SIN to DSPI_SCK input setup	21	—	ns	
DS8	DSPI_SCK to DSPI_SIN input hold	0	—	ns	

1. The DSPI module can operate across the entire operating voltage for the processor, but to run across the full voltage range the maximum frequency of operation is reduced.
2. The delay is programmable in SPI $_x$ \_CTAR $_n$ [PSSCK] and SPI $_x$ \_CTAR $_n$ [CSSCK].
3. The delay is programmable in SPI $_x$ \_CTAR $_n$ [PASC] and SPI $_x$ \_CTAR $_n$ [ASC].

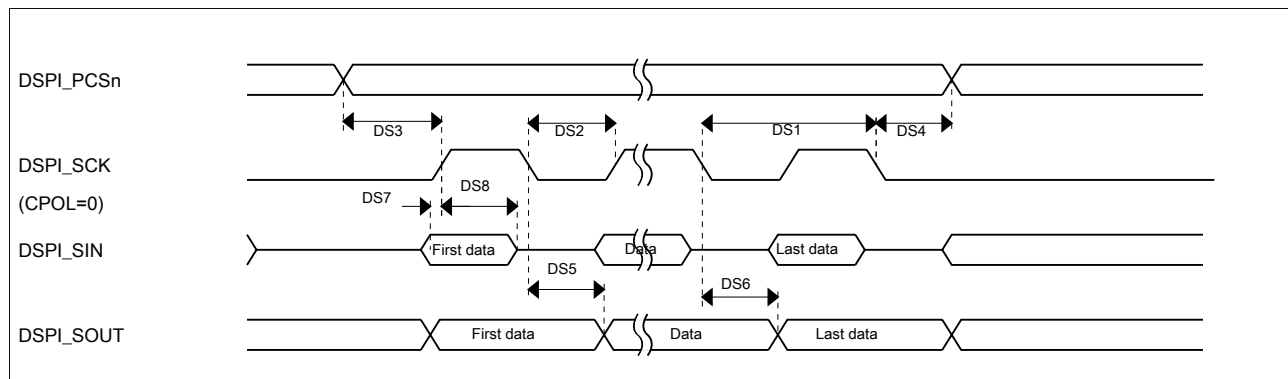

**Figure 27. DSPI classic SPI timing — master mode**

**Table 47. Slave mode DSPI timing (full voltage range)**

Num	Description	Min.	Max.	Unit
	Operating voltage	1.71	3.6	V

*Table continues on the next page...*

**Table 47. Slave mode DSPI timing (full voltage range) (continued)**

Num	Description	Min.	Max.	Unit
	Frequency of operation	—	7.5	MHz
DS9	DSPI_SCK input cycle time	$8 \times t_{BUS}$	—	ns
DS10	DSPI_SCK input high/low time	$(t_{SCK}/2) - 4$	$(t_{SCK}/2) + 4$	ns
DS11	DSPI_SCK to DSPI_SOUT valid	—	23.5	ns
DS12	DSPI_SCK to DSPI_SOUT invalid	0	—	ns
DS13	DSPI_SIN to DSPI_SCK input setup	4	—	ns
DS14	DSPI_SCK to DSPI_SIN input hold	7	—	ns
DS15	$\overline{DSPI\_SS}$ active to DSPI_SOUT driven	—	21	ns
DS16	$\overline{DSPI\_SS}$ inactive to DSPI_SOUT not driven	—	19	ns

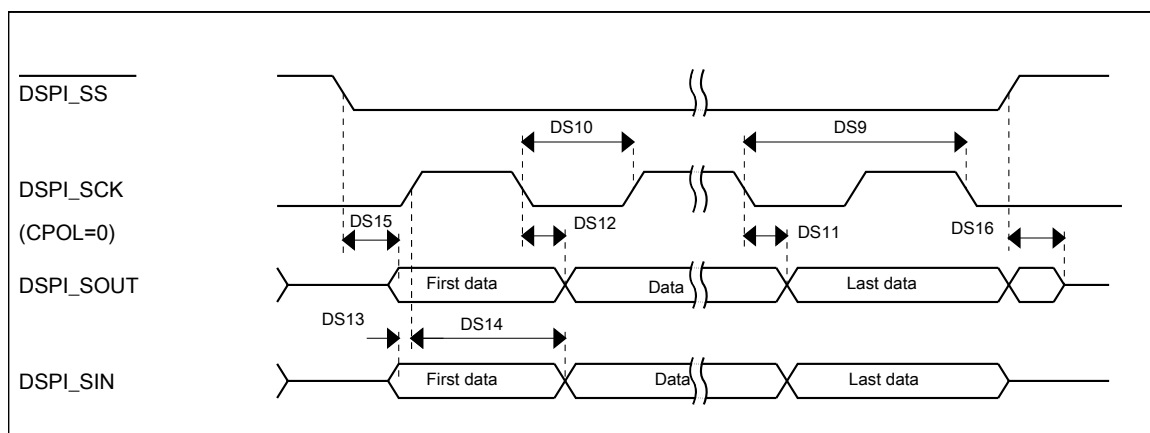
**Figure 28. DSPI classic SPI timing — slave mode**

### 3.8.8 Inter-Integrated Circuit Interface (I<sup>2</sup>C) timing

**Table 48. I<sup>2</sup>C timing**

Characteristic	Symbol	Standard Mode		Fast Mode		Unit
		Minimum	Maximum	Minimum	Maximum	
SCL Clock Frequency	$f_{SCL}$	0	100	0	400 <sup>1</sup>	kHz
Hold time (repeated) START condition. After this period, the first clock pulse is generated.	$t_{HD}; STA$	4	—	0.6	—	$\mu s$
LOW period of the SCL clock	$t_{LOW}$	4.7	—	1.25	—	$\mu s$
HIGH period of the SCL clock	$t_{HIGH}$	4	—	0.6	—	$\mu s$
Set-up time for a repeated START condition	$t_{SU}; STA$	4.7	—	0.6	—	$\mu s$
Data hold time for I <sup>2</sup> C bus devices	$t_{HD}; DAT$	0 <sup>2</sup>	3.45 <sup>3</sup>	0 <sup>4</sup>	0.9 <sup>2</sup>	$\mu s$

Table continues on the next page...

**Table 48. I<sup>2</sup>C timing (continued)**

Characteristic	Symbol	Standard Mode		Fast Mode		Unit
		Minimum	Maximum	Minimum	Maximum	
Data set-up time	t <sub>SU</sub> ; DAT	250 <sup>5</sup>	—	100 <sup>3,6</sup>	—	ns
Rise time of SDA and SCL signals	t <sub>r</sub>	—	1000	20 + 0.1C <sub>b</sub> <sup>7</sup>	300	ns
Fall time of SDA and SCL signals	t <sub>f</sub>	—	300	20 + 0.1C <sub>b</sub> <sup>6</sup>	300	ns
Set-up time for STOP condition	t <sub>SU</sub> ; STO	4	—	0.6	—	μs
Bus free time between STOP and START condition	t <sub>BUF</sub>	4.7	—	1.3	—	μs
Pulse width of spikes that must be suppressed by the input filter	t <sub>SP</sub>	N/A	N/A	0	50	ns

1. The maximum SCL Clock Frequency in Fast mode with maximum bus loading can only be achieved when using the High drive pins across the full voltage range and when using the Normal drive pins and VDD ≥ 2.7 V.
2. The master mode I<sup>2</sup>C deasserts ACK of an address byte simultaneously with the falling edge of SCL. If no slaves acknowledge this address byte, then a negative hold time can result, depending on the edge rates of the SDA and SCL lines.
3. The maximum t<sub>HD</sub>; DAT must be met only if the device does not stretch the LOW period (t<sub>LOW</sub>) of the SCL signal.
4. Input signal Slew = 10 ns and Output Load = 50 pF
5. Set-up time in slave-transmitter mode is 1 IPBus clock period, if the TX FIFO is empty.
6. A Fast mode I<sup>2</sup>C bus device can be used in a Standard mode I<sup>2</sup>C bus system, but the requirement t<sub>SU</sub>; DAT ≥ 250 ns must then be met. This is automatically the case if the device does not stretch the LOW period of the SCL signal. If such a device does stretch the LOW period of the SCL signal, then it must output the next data bit to the SDA line t<sub>rmax</sub> + t<sub>SU</sub>; DAT = 1000 + 250 = 1250 ns (according to the Standard mode I<sup>2</sup>C bus specification) before the SCL line is released.
7. C<sub>b</sub> = total capacitance of the one bus line in pF.

**Table 49. I<sup>2</sup>C 1 Mbps timing**

Characteristic	Symbol	Minimum	Maximum	Unit
SCL Clock Frequency	f <sub>SCL</sub>	0	1 <sup>1</sup>	MHz
Hold time (repeated) START condition. After this period, the first clock pulse is generated.	t <sub>HD</sub> ; STA	0.26	—	μs
LOW period of the SCL clock	t <sub>LOW</sub>	0.5	—	μs
HIGH period of the SCL clock	t <sub>HIGH</sub>	0.26	—	μs
Set-up time for a repeated START condition	t <sub>SU</sub> ; STA	0.26	—	μs
Data hold time for I <sup>2</sup> C bus devices	t <sub>HD</sub> ; DAT	0	—	μs
Data set-up time	t <sub>SU</sub> ; DAT	50	—	ns
Rise time of SDA and SCL signals	t <sub>r</sub>	20 + 0.1C <sub>b</sub> <sup>2</sup>	120	ns
Fall time of SDA and SCL signals	t <sub>f</sub>	20 + 0.1C <sub>b</sub> <sup>2</sup>	120	ns
Set-up time for STOP condition	t <sub>SU</sub> ; STO	0.26	—	μs
Bus free time between STOP and START condition	t <sub>BUF</sub>	0.5	—	μs
Pulse width of spikes that must be suppressed by the input filter	t <sub>SP</sub>	0	50	ns

1. The maximum SCL clock frequency of 1 Mbps can support maximum bus loading when using the High drive pins across the full voltage range.

## Peripheral operating requirements and behaviors

2.  $C_b$  = total capacitance of the one bus line in pF.

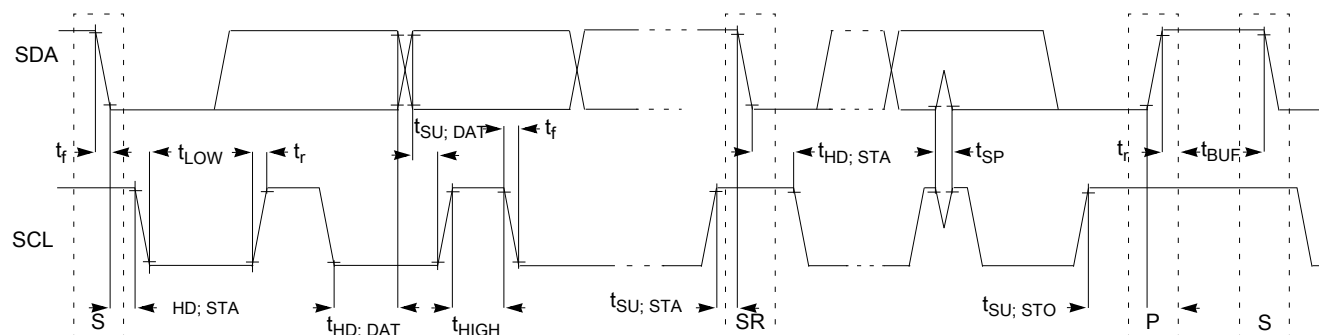

Figure 29. Timing definition for devices on the I<sup>2</sup>C bus

## 3.8.9 UART switching specifications

See [General switching specifications](#).

## 3.8.10 SDHC specifications

The following timing specs are defined at the chip I/O pin and must be translated appropriately to arrive at timing specs/constraints for the physical interface.

Table 50. SDHC switching specifications

Num	Symbol	Description	Min.	Max.	Unit
		Operating voltage	1.71	3.6	V
<b>Card input clock</b>					
SD1	f <sub>pp</sub>	Clock frequency (low speed)	0	400	kHz
	f <sub>pp</sub>	Clock frequency (SD\SDIO full speed\high speed)	0	25\50	MHz
	f <sub>pp</sub>	Clock frequency (MMC full speed\high speed)	0	20\50	MHz
	f <sub>OD</sub>	Clock frequency (identification mode)	0	400	kHz
SD2	t <sub>WL</sub>	Clock low time	7	—	ns
SD3	t <sub>WH</sub>	Clock high time	7	—	ns
SD4	t <sub>TLH</sub>	Clock rise time	—	3	ns
SD5	t <sub>THL</sub>	Clock fall time	—	3	ns
<b>SDHC output / card inputs SDHC_CMD, SDHC_DAT (reference to SDHC_CLK)</b>					
SD6	t <sub>OD</sub>	SDHC output delay (output valid)	-5	8.3	ns
<b>SDHC input / card inputs SDHC_CMD, SDHC_DAT (reference to SDHC_CLK)</b>					
SD7	t <sub>ISU</sub>	SDHC input setup time	5.5	—	ns
SD8	t <sub>IH</sub>	SDHC input hold time	0	—	ns

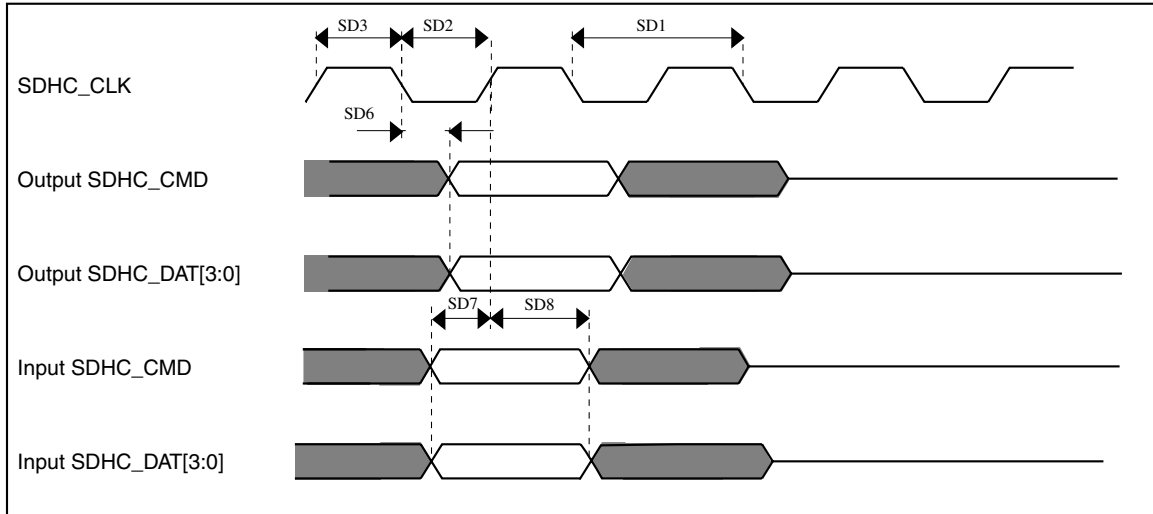

Figure 30. SDHC timing

### 3.8.11 I<sup>2</sup>S switching specifications

This section provides the AC timings for the I<sup>2</sup>S in master (clocks driven) and slave modes (clocks input). All timings are given for non-inverted serial clock polarity (TCR[TSCKP] = 0, RCR[RSCKP] = 0) and a non-inverted frame sync (TCR[TFSI] = 0, RCR[RFSI] = 0). If the polarity of the clock and/or the frame sync have been inverted, all the timings remain valid by inverting the clock signal (I2S\_BCLK) and/or the frame sync (I2S\_FS) shown in the figures below.

Table 51. I<sup>2</sup>S master mode timing

Num	Description	Min.	Max.	Unit
	Operating voltage	2.7	3.6	V
S1	I2S_MCLK cycle time	40	—	ns
S2	I2S_MCLK pulse width high/low	45%	55%	MCLK period
S3	I2S_BCLK cycle time	80	—	ns
S4	I2S_BCLK pulse width high/low	45%	55%	BCLK period
S5	I2S_BCLK to I2S_FS output valid	—	15	ns
S6	I2S_BCLK to I2S_FS output invalid	0	—	ns
S7	I2S_BCLK to I2S_TXD valid	—	15	ns
S8	I2S_BCLK to I2S_TXD invalid	0	—	ns
S9	I2S_RXD/I2S_FS input setup before I2S_BCLK	17	—	ns
S10	I2S_RXD/I2S_FS input hold after I2S_BCLK	0	—	ns

## Peripheral operating requirements and behaviors

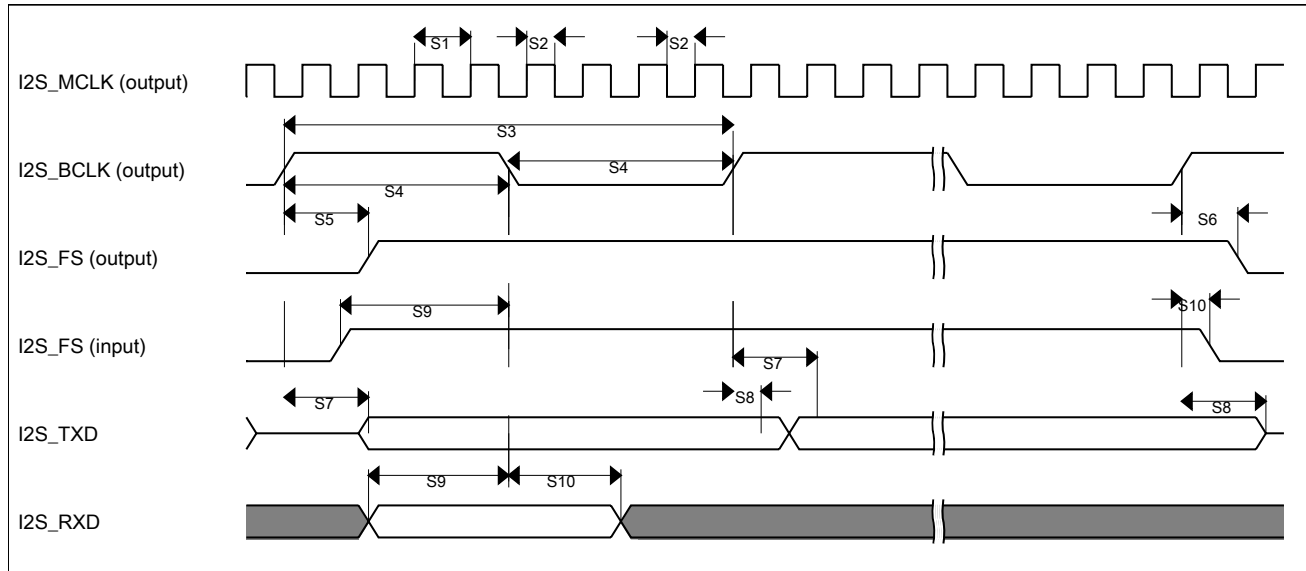
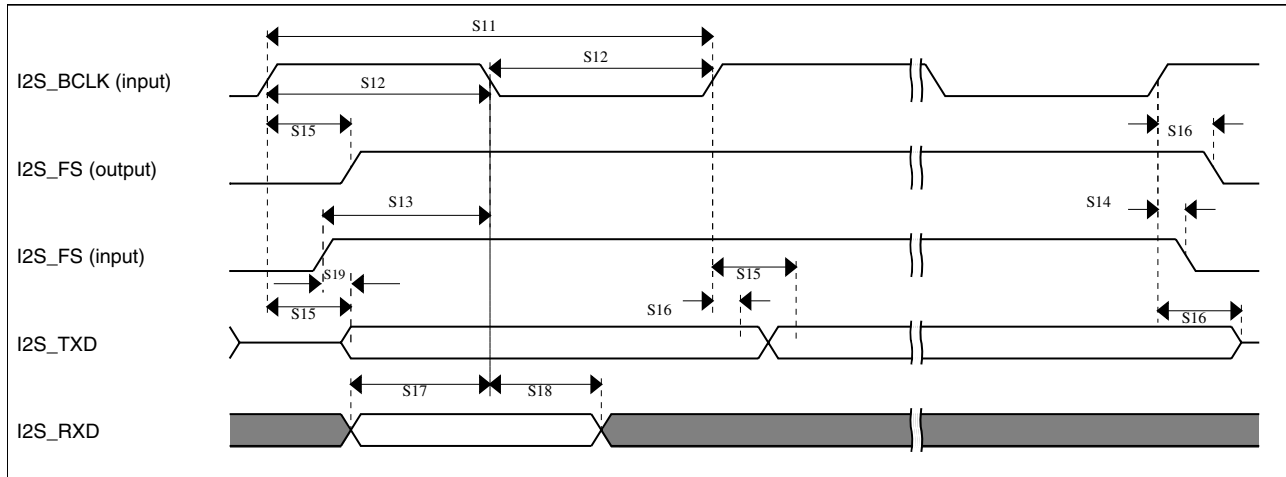

**Figure 31. I<sup>2</sup>S timing — master mode**

**Table 52. I<sup>2</sup>S slave mode timing**

Num	Description	Min.	Max.	Unit
	Operating voltage	2.7	3.6	V
S11	I2S_BCLK cycle time (input)	80	—	ns
S12	I2S_BCLK pulse width high/low (input)	45%	55%	MCLK period
S13	I2S_FS input setup before I2S_BCLK	5	—	ns
S14	I2S_FS input hold after I2S_BCLK	2	—	ns
S15	I2S_BCLK to I2S_TXD/I2S_FS output valid	—	19.5	ns
S16	I2S_BCLK to I2S_TXD/I2S_FS output invalid	0	—	ns
S17	I2S_RXD setup before I2S_BCLK	5	—	ns
S18	I2S_RXD hold after I2S_BCLK	2	—	ns
S19	I2S_TX_FS input assertion to I2S_TXD output valid <sup>1</sup>		21	ns

1. Applies to first bit in each frame and only if the TCR4[FSE] bit is clear

Figure 32. I<sup>2</sup>S timing — slave modes

### 3.8.11.1 Normal Run, Wait and Stop mode performance over the full operating voltage range

This section provides the operating performance over the full operating voltage for the device in Normal Run, Wait and Stop modes.

Table 53. I2S/SAI master mode timing

Num.	Characteristic	Min.	Max.	Unit
	Operating voltage	1.71	3.6	V
S1	I2S_MCLK cycle time	40	—	ns
S2	I2S_MCLK (as an input) pulse width high/low	45%	55%	MCLK period
S3	I2S_TX_BCLK/I2S_RX_BCLK cycle time (output)	80	—	ns
S4	I2S_TX_BCLK/I2S_RX_BCLK pulse width high/low	45%	55%	BCLK period
S5	I2S_TX_BCLK/I2S_RX_BCLK to I2S_TX_FS/ I2S_RX_FS output valid	—	15	ns
S6	I2S_TX_BCLK/I2S_RX_BCLK to I2S_TX_FS/ I2S_RX_FS output invalid	-1	—	ns
S7	I2S_TX_BCLK to I2S_TXD valid	—	15	ns
S8	I2S_TX_BCLK to I2S_TXD invalid	0	—	ns
S9	I2S_RXD/I2S_RX_FS input setup before I2S_RX_BCLK	22.5	—	ns
S10	I2S_RXD/I2S_RX_FS input hold after I2S_RX_BCLK	0	—	ns

## Peripheral operating requirements and behaviors

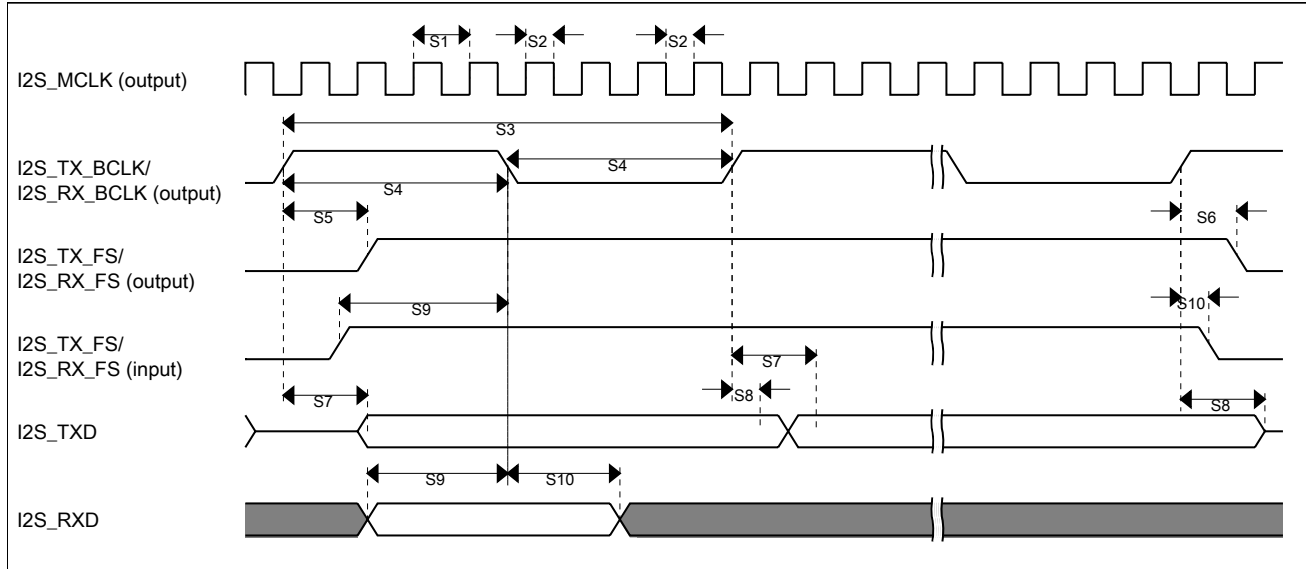

**Figure 33. I2S/SAI timing — master modes**

**Table 54. I2S/SAI slave mode timing**

Num.	Characteristic	Min.	Max.	Unit
	Operating voltage	1.71	3.6	V
S11	I2S_TX_BCLK/I2S_RX_BCLK cycle time (input)	80	—	ns
S12	I2S_TX_BCLK/I2S_RX_BCLK pulse width high/low (input)	45%	55%	MCLK period
S13	I2S_TX_FS/I2S_RX_FS input setup before I2S_TX_BCLK/I2S_RX_BCLK	7	—	ns
S14	I2S_TX_FS/I2S_RX_FS input hold after I2S_TX_BCLK/I2S_RX_BCLK	2	—	ns
S15	I2S_TX_BCLK to I2S_TXD/I2S_TX_FS output valid	—	25.5	ns
S16	I2S_TX_BCLK to I2S_TXD/I2S_TX_FS output invalid	3	—	ns
S17	I2S_RXD setup before I2S_RX_BCLK	5.8	—	ns
S18	I2S_RXD hold after I2S_RX_BCLK	2	—	ns
S19	I2S_TX_FS input assertion to I2S_TXD output valid <sup>1</sup>	—	25	ns

1. Applies to first bit in each frame and only if the TCR4[FSE] bit is clear



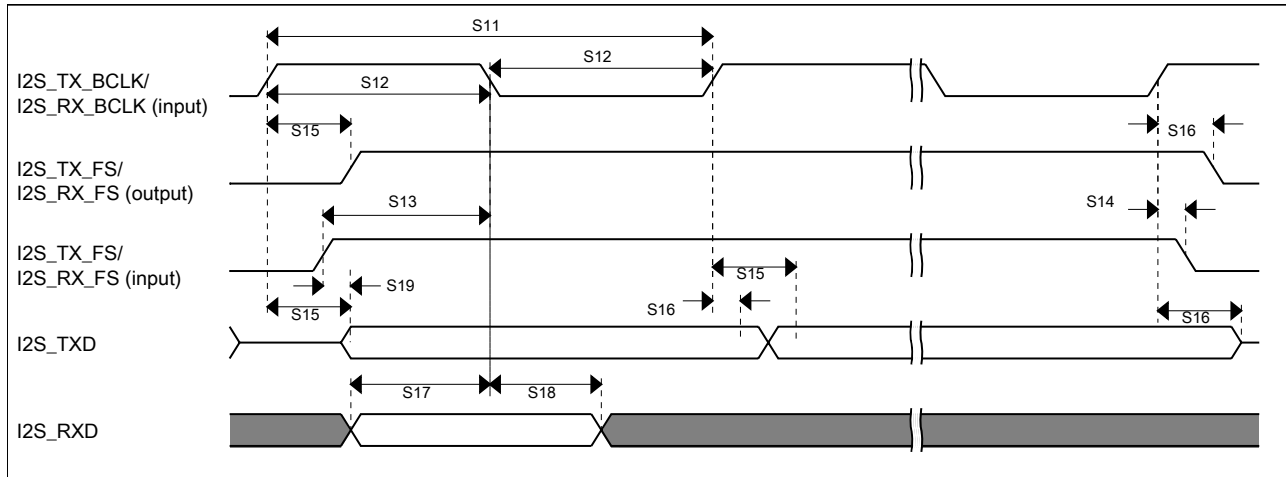

Figure 34. I2S/SAI timing — slave modes

### 3.8.11.2 VLPR, VLPW, and VLPS mode performance over the full operating voltage range

This section provides the operating performance over the full operating voltage for the device in VLPR, VLPW, and VLPS modes.

Table 55. I2S/SAI master mode timing in VLPR, VLPW, and VLPS modes (full voltage range)

Num.	Characteristic	Min.	Max.	Unit
	Operating voltage	1.71	3.6	V
S1	I2S_MCLK cycle time	62.5	—	ns
S2	I2S_MCLK pulse width high/low	45%	55%	MCLK period
S3	I2S_TX_BCLK/I2S_RX_BCLK cycle time (output)	250	—	ns
S4	I2S_TX_BCLK/I2S_RX_BCLK pulse width high/low	45%	55%	BCLK period
S5	I2S_TX_BCLK/I2S_RX_BCLK to I2S_TX_FS/ I2S_RX_FS output valid	—	45	ns
S6	I2S_TX_BCLK/I2S_RX_BCLK to I2S_TX_FS/ I2S_RX_FS output invalid	0	—	ns
S7	I2S_TX_BCLK to I2S_TXD valid	—	45	ns
S8	I2S_TX_BCLK to I2S_TXD invalid		—	ns
S9	I2S_RXD/I2S_RX_FS input setup before I2S_RX_BCLK	45	—	ns
S10	I2S_RXD/I2S_RX_FS input hold after I2S_RX_BCLK	0	—	ns

Peripheral operating requirements and behaviors

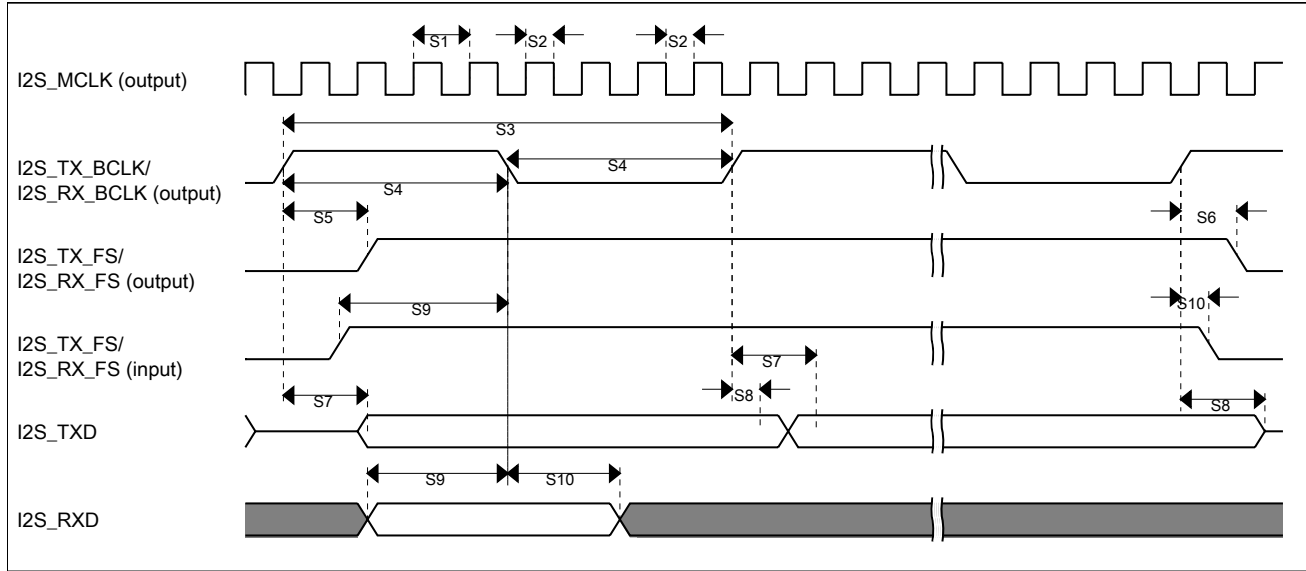

Figure 35. I2S/SAI timing — master modes

Table 56. I2S/SAI slave mode timing in VLPR, VLPW, and VLPS modes (full voltage range)

Num.	Characteristic	Min.	Max.	Unit
	Operating voltage	1.71	3.6	V
S11	I2S_TX_BCLK/I2S_RX_BCLK cycle time (input)	250	—	ns
S12	I2S_TX_BCLK/I2S_RX_BCLK pulse width high/low (input)	45%	55%	MCLK period
S13	I2S_TX_FS/I2S_RX_FS input setup before I2S_TX_BCLK/I2S_RX_BCLK	30	—	ns
S14	I2S_TX_FS/I2S_RX_FS input hold after I2S_TX_BCLK/I2S_RX_BCLK	11	—	ns
S15	I2S_TX_BCLK to I2S_TXD/I2S_TX_FS output valid	—	—	ns
S16	I2S_TX_BCLK to I2S_TXD/I2S_TX_FS output invalid	0	—	ns
S17	I2S_RXD setup before I2S_RX_BCLK	30	—	ns
S18	I2S_RXD hold after I2S_RX_BCLK	11	—	ns
S19	I2S_TX_FS input assertion to I2S_TXD output valid <sup>1</sup>	—	72	ns

1. Applies to first bit in each frame and only if the TCR4[FSE] bit is clear

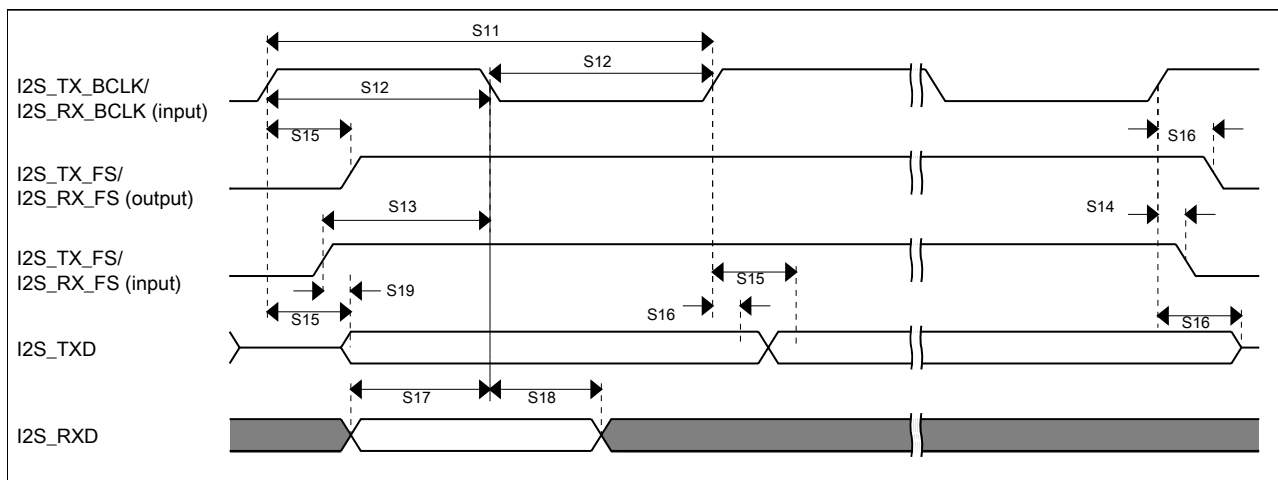

Figure 36. I2S/SAI timing — slave modes

## 4 Dimensions

### 4.1 Obtaining package dimensions

Package dimensions are provided in package drawings.

To find a package drawing, go to [nxp.com](http://nxp.com) and perform a keyword search for the drawing's document number:

If you want the drawing for this package	Then use this document number
100-pin LQFP	98ASS23308W
121-pin XFBGA	98ASA00595D
144-pin LQFP	98ASS23177W
144-pin MAPBGA	98ASA00222D

## 5 Pinout

## 5.1 K64 Signal Multiplexing and Pin Assignments

The following table shows the signals available on each pin and the locations of these pins on the devices supported by this document. The Port Control Module is responsible for selecting which ALT functionality is available on each pin.

144 LQFP	144 MAP BGA	121 XFB GA	100 LQFP	Pin Name	Default	ALT0	ALT1	ALT2	ALT3	ALT4	ALT5	ALT6	ALT7	EzPort
—	L5	L7	—	RTC_WAKEUP_B	RTC_WAKEUP_B	RTC_WAKEUP_B								
—	—	B11	—	PTB12	DISABLED		PTB12	UART3_RTS_b	FTM1_CH0	FTM0_CH4		FTM1_QD_PHA		
—	—	C11	—	PTB13	DISABLED		PTB13	UART3_CTS_b	FTM1_CH1	FTM0_CH5		FTM1_QD_PHB		
—	—	A11	—	NC	NC	NC								
—	M5	—	—	NC	NC	NC								
—	A10	—	—	NC	NC	NC								
—	B10	K3	—	NC	NC	NC								
—	C10	H4	—	NC	NC	NC								
1	D3	E4	1	PTE0	ADC1_SE4a	ADC1_SE4a	PTE0	SPI1_PCS1	UART1_TX	SDHC0_D1	TRACE_CLKOUT	I2C1_SDA	RTC_CLKOUT	
2	D2	E3	2	PTE1/LLWU_P0	ADC1_SE5a	ADC1_SE5a	PTE1/LLWU_P0	SPI1_SOUT	UART1_RX	SDHC0_D0	TRACE_D3	I2C1_SCL	SPI1_SIN	
3	D1	E2	3	PTE2/LLWU_P1	ADC0_DP2/ADC1_SE6a	ADC0_DP2/ADC1_SE6a	PTE2/LLWU_P1	SPI1_SCK	UART1_CTS_b	SDHC0_DCLK	TRACE_D2			
4	E4	F4	4	PTE3	ADC0_DM2/ADC1_SE7a	ADC0_DM2/ADC1_SE7a	PTE3	SPI1_SIN	UART1_RTS_b	SDHC0_CMD	TRACE_D1		SPI1_SOUT	
5	E5	E7	—	VDD	VDD	VDD								
6	F6	F7	—	VSS	VSS	VSS								
7	E3	H7	5	PTE4/LLWU_P2	DISABLED		PTE4/LLWU_P2	SPI1_PCS0	UART3_TX	SDHC0_D3	TRACE_D0			
8	E2	G4	6	PTE5	DISABLED		PTE5	SPI1_PCS2	UART3_RX	SDHC0_D2		FTM3_CH0		
9	E1	F3	7	PTE6	DISABLED		PTE6	SPI1_PCS3	UART3_CTS_b	I2S0_MCLK		FTM3_CH1	USB_SOF_OUT	
10	F4	—	—	PTE7	DISABLED		PTE7		UART3_RTS_b	I2S0_RXD0		FTM3_CH2		
11	F3	—	—	PTE8	DISABLED		PTE8	I2S0_RXD1	UART5_TX	I2S0_RX_FS		FTM3_CH3		
12	F2	—	—	PTE9	DISABLED		PTE9	I2S0_TXD1	UART5_RX	I2S0_RX_BCLK		FTM3_CH4		
13	F1	—	—	PTE10	DISABLED		PTE10		UART5_CTS_b	I2S0_TXD0		FTM3_CH5		

144 LQFP	144 MAP BGA	121 XFB GA	100 LQFP	Pin Name	Default	ALT0	ALT1	ALT2	ALT3	ALT4	ALT5	ALT6	ALT7	EzPort
14	G4	—	—	PTE11	DISABLED		PTE11		UART5_RTS_b	I2S0_TX_FS		FTM3_CH6		
15	G3	—	—	PTE12	DISABLED		PTE12			I2S0_TX_BCLK		FTM3_CH7		
16	E6	E6	8	VDD	VDD	VDD								
17	F7	G7	9	VSS	VSS	VSS								
18	H3	L6	—	VSS	VSS	VSS								
19	H1	F1	10	USB0_DP	USB0_DP	USB0_DP								
20	H2	F2	11	USB0_DM	USB0_DM	USB0_DM								
21	G1	G1	12	VOUT33	VOUT33	VOUT33								
22	G2	G2	13	VREGIN	VREGIN	VREGIN								
23	J1	H1	14	ADC0_DP1	ADC0_DP1	ADC0_DP1								
24	J2	H2	15	ADC0_DM1	ADC0_DM1	ADC0_DM1								
25	K1	J1	16	ADC1_DP1	ADC1_DP1	ADC1_DP1								
26	K2	J2	17	ADC1_DM1	ADC1_DM1	ADC1_DM1								
27	L1	K1	18	ADC0_DP0/ ADC1_DP3	ADC0_DP0/ ADC1_DP3	ADC0_DP0/ ADC1_DP3								
28	L2	K2	19	ADC0_DM0/ ADC1_DM3	ADC0_DM0/ ADC1_DM3	ADC0_DM0/ ADC1_DM3								
29	M1	L1	20	ADC1_DP0/ ADC0_DP3	ADC1_DP0/ ADC0_DP3	ADC1_DP0/ ADC0_DP3								
30	M2	L2	21	ADC1_DM0/ ADC0_DM3	ADC1_DM0/ ADC0_DM3	ADC1_DM0/ ADC0_DM3								
31	H5	F5	22	VDDA	VDDA	VDDA								
32	G5	G5	23	VREFH	VREFH	VREFH								
33	G6	G6	24	VREFL	VREFL	VREFL								
34	H6	F6	25	VSSA	VSSA	VSSA								
35	K3	J3	—	ADC1_SE16/ CMP2_IN2/ ADC0_SE22	ADC1_SE16/ CMP2_IN2/ ADC0_SE22	ADC1_SE16/ CMP2_IN2/ ADC0_SE22								
36	J3	H3	—	ADC0_SE16/ CMP1_IN2/ ADC0_SE21	ADC0_SE16/ CMP1_IN2/ ADC0_SE21	ADC0_SE16/ CMP1_IN2/ ADC0_SE21								
37	M3	L3	26	VREF_OUT/ CMP1_IN5/ CMP0_IN5/ ADC1_SE18	VREF_OUT/ CMP1_IN5/ CMP0_IN5/ ADC1_SE18	VREF_OUT/ CMP1_IN5/ CMP0_IN5/ ADC1_SE18								

## Pinout

144 LQFP	144 MAP BGA	121 XFB GA	100 LQFP	Pin Name	Default	ALT0	ALT1	ALT2	ALT3	ALT4	ALT5	ALT6	ALT7	EzPort
38	L3	K5	27	DAC0_OUT/ CMP1_IN3/ ADC0_SE23	DAC0_OUT/ CMP1_IN3/ ADC0_SE23	DAC0_OUT/ CMP1_IN3/ ADC0_SE23								
39	L4	K4	—	DAC1_OUT/ CMP0_IN4/ CMP2_IN3/ ADC1_SE23	DAC1_OUT/ CMP0_IN4/ CMP2_IN3/ ADC1_SE23	DAC1_OUT/ CMP0_IN4/ CMP2_IN3/ ADC1_SE23								
40	M7	L4	28	XTAL32	XTAL32	XTAL32								
41	M6	L5	29	EXTAL32	EXTAL32	EXTAL32								
42	L6	K6	30	VBAT	VBAT	VBAT								
43	—	—	—	VDD	VDD	VDD								
44	—	—	—	VSS	VSS	VSS								
45	M4	H5	31	PTE24	ADC0_SE17	ADC0_SE17	PTE24		UART4_TX		I2C0_SCL	EWM_OUT_b		
46	K5	J5	32	PTE25	ADC0_SE18	ADC0_SE18	PTE25		UART4_RX		I2C0_SDA	EWM_IN		
47	K4	H6	33	PTE26	DISABLED		PTE26	ENET_1588_CLKIN	UART4_CTS_b			RTC_CLKOUT	USB_CLKIN	
48	J4	—	—	PTE27	DISABLED		PTE27		UART4_RTS_b					
49	H4	—	—	PTE28	DISABLED		PTE28							
50	J5	J6	34	PTA0	JTAG_TCLK/ SWD_CLK/ EZP_CLK		PTA0	UART0_CTS_b/ UART0_COL_b	FTM0_CH5				JTAG_TCLK/ SWD_CLK	EZP_CLK
51	J6	H8	35	PTA1	JTAG_TDI/ EZP_DI		PTA1	UART0_RX	FTM0_CH6				JTAG_TDI	EZP_DI
52	K6	J7	36	PTA2	JTAG_TDO/ TRACE_SWO/ EZP_DO		PTA2	UART0_TX	FTM0_CH7				JTAG_TDO/ TRACE_SWO	EZP_DO
53	K7	H9	37	PTA3	JTAG_TMS/ SWD_DIO		PTA3	UART0_RTS_b	FTM0_CH0				JTAG_TMS/ SWD_DIO	
54	L7	J8	38	PTA4/ LLWU_P3	NMI_b/ EZP_CS_b		PTA4/ LLWU_P3		FTM0_CH1				NMI_b	EZP_CS_b
55	M8	K7	39	PTA5	DISABLED		PTA5	USB_CLKIN	FTM0_CH2	RMII0_RXER/ MII0_RXER	CMP2_OUT	I2S0_TX_BCLK	JTAG_TRST_b	
56	E7	E5	40	VDD	VDD	VDD								
57	G7	G3	41	VSS	VSS	VSS								

144 LQFP	144 MAP BGA	121 XFB GA	100 LQFP	Pin Name	Default	ALT0	ALT1	ALT2	ALT3	ALT4	ALT5	ALT6	ALT7	EzPort
58	J7	—	—	PTA6	DISABLED		PTA6		FTM0_CH3		CLKOUT		TRACE_CLKOUT	
59	J8	—	—	PTA7	ADC0_SE10	ADC0_SE10	PTA7		FTM0_CH4				TRACE_D3	
60	K8	—	—	PTA8	ADC0_SE11	ADC0_SE11	PTA8		FTM1_CH0			FTM1_QD_PHA	TRACE_D2	
61	L8	—	—	PTA9	DISABLED		PTA9		FTM1_CH1	MII0_RXD3		FTM1_QD_PHB	TRACE_D1	
62	M9	J9	—	PTA10	DISABLED		PTA10		FTM2_CH0	MII0_RXD2		FTM2_QD_PHA	TRACE_D0	
63	L9	J4	—	PTA11	DISABLED		PTA11		FTM2_CH1	MII0_RXCLK	I2C2_SDA	FTM2_QD_PHB		
64	K9	K8	42	PTA12	CMP2_IN0	CMP2_IN0	PTA12	CAN0_TX	FTM1_CH0	RMII0_RXD1/ MII0_RXD1	I2C2_SCL	I2S0_TXD0	FTM1_QD_PHA	
65	J9	L8	43	PTA13/ LLWU_P4	CMP2_IN1	CMP2_IN1	PTA13/ LLWU_P4	CAN0_RX	FTM1_CH1	RMII0_RXD0/ MII0_RXD0	I2C2_SDA	I2S0_TX_FS	FTM1_QD_PHB	
66	L10	K9	44	PTA14	DISABLED		PTA14	SPI0_PCS0	UART0_TX	RMII0_CRSDV/ MII0_RXDV	I2C2_SCL	I2S0_RX_BCLK	I2S0_TXD1	
67	L11	L9	45	PTA15	DISABLED		PTA15	SPI0_SCK	UART0_RX	RMII0_TXEN/ MII0_TXEN		I2S0_RXD0		
68	K10	J10	46	PTA16	DISABLED		PTA16	SPI0_SOUT	UART0_CTS_b/ UART0_COL_b	RMII0_TXD0/ MII0_TXD0		I2S0_RX_FS	I2S0_RXD1	
69	K11	H10	47	PTA17	ADC1_SE17	ADC1_SE17	PTA17	SPI0_SIN	UART0_RTS_b	RMII0_TXD1/ MII0_TXD1		I2S0_MCLK		
70	E8	L10	48	VDD	VDD	VDD								
71	G8	K10	49	VSS	VSS	VSS								
72	M12	L11	50	PTA18	EXTAL0	EXTAL0	PTA18		FTM0_FLT2	FTM_CLKIN0				
73	M11	K11	51	PTA19	XTAL0	XTAL0	PTA19		FTM1_FLT0	FTM_CLKIN1		LPTMR0_ALT1		
74	L12	J11	52	RESET_b	RESET_b	RESET_b								
75	K12	—	—	PTA24	DISABLED		PTA24			MII0_TXD2		FB_A29		
76	J12	—	—	PTA25	DISABLED		PTA25			MII0_TXCLK		FB_A28		
77	J11	—	—	PTA26	DISABLED		PTA26			MII0_TXD3		FB_A27		
78	J10	—	—	PTA27	DISABLED		PTA27			MII0_CRS		FB_A26		
79	H12	—	—	PTA28	DISABLED		PTA28			MII0_TXER		FB_A25		
80	H11	H11	—	PTA29	DISABLED		PTA29			MII0_COL		FB_A24		

## Pinout

144 LQFP	144 MAP BGA	121 XFB GA	100 LQFP	Pin Name	Default	ALT0	ALT1	ALT2	ALT3	ALT4	ALT5	ALT6	ALT7	EzPort
81	H10	G11	53	PTB0/ LLWU_P5	ADC0_SE8/ ADC1_SE8	ADC0_SE8/ ADC1_SE8	PTB0/ LLWU_P5	I2C0_SCL	FTM1_CH0	RMIIO_ MDIO/ MIIO_MDIO		FTM1_QD_ PHA		
82	H9	G10	54	PTB1	ADC0_SE9/ ADC1_SE9	ADC0_SE9/ ADC1_SE9	PTB1	I2C0_SDA	FTM1_CH1	RMIIO_ MDC/ MIIO_MDC		FTM1_QD_ PHB		
83	G12	G9	55	PTB2	ADC0_ SE12	ADC0_ SE12	PTB2	I2C0_SCL	UART0_ RTS_b	ENET0_ 1588_ TMR0		FTM0_ FLT3		
84	G11	G8	56	PTB3	ADC0_ SE13	ADC0_ SE13	PTB3	I2C0_SDA	UART0_ CTS_b/ UART0_ COL_b	ENET0_ 1588_ TMR1		FTM0_ FLT0		
85	G10	—	—	PTB4	ADC1_ SE10	ADC1_ SE10	PTB4			ENET0_ 1588_ TMR2		FTM1_ FLT0		
86	G9	—	—	PTB5	ADC1_ SE11	ADC1_ SE11	PTB5			ENET0_ 1588_ TMR3		FTM2_ FLT0		
87	F12	F11	—	PTB6	ADC1_ SE12	ADC1_ SE12	PTB6				FB_AD23			
88	F11	E11	—	PTB7	ADC1_ SE13	ADC1_ SE13	PTB7				FB_AD22			
89	F10	D11	—	PTB8	DISABLED		PTB8		UART3_ RTS_b		FB_AD21			
90	F9	E10	57	PTB9	DISABLED		PTB9	SPI1_PCS1	UART3_ CTS_b		FB_AD20			
91	E12	D10	58	PTB10	ADC1_ SE14	ADC1_ SE14	PTB10	SPI1_PCS0	UART3_RX		FB_AD19	FTM0_ FLT1		
92	E11	C10	59	PTB11	ADC1_ SE15	ADC1_ SE15	PTB11	SPI1_SCK	UART3_TX		FB_AD18	FTM0_ FLT2		
93	H7	—	60	VSS	VSS	VSS								
94	F5	—	61	VDD	VDD	VDD								
95	E10	B10	62	PTB16	DISABLED		PTB16	SPI1_ SOUT	UART0_RX	FTM_ CLKIN0	FB_AD17	EWM_IN		
96	E9	E9	63	PTB17	DISABLED		PTB17	SPI1_SIN	UART0_TX	FTM_ CLKIN1	FB_AD16	EWM_ OUT_b		
97	D12	D9	64	PTB18	DISABLED		PTB18	CAN0_TX	FTM2_CH0	I2S0_TX_ BCLK	FB_AD15	FTM2_QD_ PHA		
98	D11	C9	65	PTB19	DISABLED		PTB19	CAN0_RX	FTM2_CH1	I2S0_TX_ FS	FB_OE_b	FTM2_QD_ PHB		
99	D10	F10	66	PTB20	DISABLED		PTB20	SPI2_PCS0			FB_AD31	CMP0_OUT		
100	D9	F9	67	PTB21	DISABLED		PTB21	SPI2_SCK			FB_AD30	CMP1_OUT		
101	C12	F8	68	PTB22	DISABLED		PTB22	SPI2_ SOUT			FB_AD29	CMP2_OUT		
102	C11	E8	69	PTB23	DISABLED		PTB23	SPI2_SIN	SPI0_PCS5		FB_AD28			



144 LQFP	144 MAP BGA	121 XFB GA	100 LQFP	Pin Name	Default	ALT0	ALT1	ALT2	ALT3	ALT4	ALT5	ALT6	ALT7	EzPort
103	B12	B9	70	PTC0	ADC0_SE14	ADC0_SE14	PTC0	SPI0_PCS4	PDB0_EXTRG	USB_SOF_OUT	FB_AD14	I2S0_TXD1		
104	B11	D8	71	PTC1/LLWU_P6	ADC0_SE15	ADC0_SE15	PTC1/LLWU_P6	SPI0_PCS3	UART1_RTS_b	FTM0_CH0	FB_AD13	I2S0_TXD0		
105	A12	C8	72	PTC2	ADC0_SE4b/CMP1_IN0	ADC0_SE4b/CMP1_IN0	PTC2	SPI0_PCS2	UART1_CTS_b	FTM0_CH1	FB_AD12	I2S0_TX_FS		
106	A11	B8	73	PTC3/LLWU_P7	CMP1_IN1	CMP1_IN1	PTC3/LLWU_P7	SPI0_PCS1	UART1_RX	FTM0_CH2	CLKOUT	I2S0_TX_BCLK		
107	H8	—	74	VSS	VSS	VSS								
108	—	—	75	VDD	VDD	VDD								
109	A9	A8	76	PTC4/LLWU_P8	DISABLED		PTC4/LLWU_P8	SPI0_PCS0	UART1_TX	FTM0_CH3	FB_AD11	CMP1_OUT		
110	D8	D7	77	PTC5/LLWU_P9	DISABLED		PTC5/LLWU_P9	SPI0_SCK	LPTMR0_ALT2	I2S0_RXD0	FB_AD10	CMP0_OUT	FTM0_CH2	
111	C8	C7	78	PTC6/LLWU_P10	CMP0_IN0	CMP0_IN0	PTC6/LLWU_P10	SPI0_SOUT	PDB0_EXTRG	I2S0_RX_BCLK	FB_AD9	I2S0_MCLK		
112	B8	B7	79	PTC7	CMP0_IN1	CMP0_IN1	PTC7	SPI0_SIN	USB_SOF_OUT	I2S0_RX_FS	FB_AD8			
113	A8	A7	80	PTC8	ADC1_SE4b/CMP0_IN2	ADC1_SE4b/CMP0_IN2	PTC8		FTM3_CH4	I2S0_MCLK	FB_AD7			
114	D7	D6	81	PTC9	ADC1_SE5b/CMP0_IN3	ADC1_SE5b/CMP0_IN3	PTC9		FTM3_CH5	I2S0_RX_BCLK	FB_AD6	FTM2_FLT0		
115	C7	C6	82	PTC10	ADC1_SE6b	ADC1_SE6b	PTC10	I2C1_SCL	FTM3_CH6	I2S0_RX_FS	FB_AD5			
116	B7	C5	83	PTC11/LLWU_P11	ADC1_SE7b	ADC1_SE7b	PTC11/LLWU_P11	I2C1_SDA	FTM3_CH7	I2S0_RXD1	FB_RW_b			
117	A7	B6	84	PTC12	DISABLED		PTC12		UART4_RTS_b		FB_AD27	FTM3_FLT0		
118	D6	A6	85	PTC13	DISABLED		PTC13		UART4_CTS_b		FB_AD26			
119	C6	A5	86	PTC14	DISABLED		PTC14		UART4_RX		FB_AD25			
120	B6	B5	87	PTC15	DISABLED		PTC15		UART4_TX		FB_AD24			
121	—	—	88	VSS	VSS	VSS								
122	—	—	89	VDD	VDD	VDD								
123	A6	D5	90	PTC16	DISABLED		PTC16		UART3_RX	ENET0_1588_TMR0	FB_CS5_b/ FB_TSI21/ FB_BE23_16_BLS15_8_b			
124	D5	C4	91	PTC17	DISABLED		PTC17		UART3_TX	ENET0_1588_TMR1	FB_CS4_b/ FB_TSI20/ FB_BE31_			

## Pinout

144 LQFP	144 MAP BGA	121 XFB GA	100 LQFP	Pin Name	Default	ALT0	ALT1	ALT2	ALT3	ALT4	ALT5	ALT6	ALT7	EzPort
											24_BLS7_0_b			
125	C5	B4	92	PTC18	DISABLED		PTC18		UART3_RTS_b	ENET0_1588_TMR2	FB_TBST_b/ FB_CS2_b/ FB_BE15_8_BLS23_16_b			
126	B5	A4	—	PTC19	DISABLED		PTC19		UART3_CTS_b	ENET0_1588_TMR3	FB_CS3_b/ FB_BE7_0_BLS31_24_b	FB_TA_b		
127	A5	D4	93	PTD0/ LLWU_P12	DISABLED		PTD0/ LLWU_P12	SPI0_PCS0	UART2_RTS_b	FTM3_CH0	FB_ALE/ FB_CS1_b/ FB_TS_b			
128	D4	D3	94	PTD1	ADC0_SE5b	ADC0_SE5b	PTD1	SPI0_SCK	UART2_CTS_b	FTM3_CH1	FB_CS0_b			
129	C4	C3	95	PTD2/ LLWU_P13	DISABLED		PTD2/ LLWU_P13	SPI0_SOUT	UART2_RX	FTM3_CH2	FB_AD4		I2C0_SCL	
130	B4	B3	96	PTD3	DISABLED		PTD3	SPI0_SIN	UART2_TX	FTM3_CH3	FB_AD3		I2C0_SDA	
131	A4	A3	97	PTD4/ LLWU_P14	DISABLED		PTD4/ LLWU_P14	SPI0_PCS1	UART0_RTS_b	FTM0_CH4	FB_AD2	EWM_IN	SPI1_PCS0	
132	A3	A2	98	PTD5	ADC0_SE6b	ADC0_SE6b	PTD5	SPI0_PCS2	UART0_CTS_b/ UART0_COL_b	FTM0_CH5	FB_AD1	EWM_OUT_b	SPI1_SCK	
133	A2	B2	99	PTD6/ LLWU_P15	ADC0_SE7b	ADC0_SE7b	PTD6/ LLWU_P15	SPI0_PCS3	UART0_RX	FTM0_CH6	FB_AD0	FTM0_FLT0	SPI1_SOUT	
134	M10	—	—	VSS	VSS	VSS								
135	F8	—	—	VDD	VDD	VDD								
136	A1	A1	100	PTD7	DISABLED		PTD7	CMT_IRO	UART0_TX	FTM0_CH7		FTM0_FLT1	SPI1_SIN	
137	C9	A10	—	PTD8	DISABLED		PTD8	I2C0_SCL	UART5_RX			FB_A16		
138	B9	A9	—	PTD9	DISABLED		PTD9	I2C0_SDA	UART5_TX			FB_A17		
139	B3	B1	—	PTD10	DISABLED		PTD10		UART5_RTS_b			FB_A18		
140	B2	C2	—	PTD11	DISABLED		PTD11	SPI2_PCS0	UART5_CTS_b	SDHC0_CLKIN		FB_A19		
141	B1	C1	—	PTD12	DISABLED		PTD12	SPI2_SCK	FTM3_FLT0	SDHC0_D4		FB_A20		
142	C3	D2	—	PTD13	DISABLED		PTD13	SPI2_SOUT		SDHC0_D5		FB_A21		
143	C2	D1	—	PTD14	DISABLED		PTD14	SPI2_SIN		SDHC0_D6		FB_A22		
144	C1	E1	—	PTD15	DISABLED		PTD15	SPI2_PCS1		SDHC0_D7		FB_A23		

## 5.2 Unused analog interfaces

**Table 57. Unused analog interfaces**

Module name	Pins	Recommendation if unused
ADC	ADC0_DP1, ADC0_DM1, ADC1_DP1, ADC1_DM1, ADC0_DP0/ADC1_DP3, ADC0_DM0/ADC1_DM3, ADC1_DP0/ADC0_DP3, ADC1_DM0/ADC0_DM3, ADC1_SE16/ADC0_SE22, ADC0_SE16/ADC0_SE21, ADC1_SE18	Ground
DAC <sup>1</sup>	DAC0_OUT, DAC1_OUT	Float
USB	VREGIN, USB0_GND, VOUT33 <sup>2</sup>	Connect VREGIN and VOUT33 together and tie to ground through a 10 kΩ resistor. Do not tie directly to ground, as this causes a latch-up risk.
	USB0_DM, USB0_DP	Float

1. Unused DAC signals do not apply to all parts. See the [Pinout](#) section for details.
2. USB0\_VBUS and USB0\_GND are board level signals

## 5.3 K64 Pinouts

The below figure shows the pinout diagram for the devices supported by this document. Many signals may be multiplexed onto a single pin. To determine what signals can be used on which pin, see the previous section.

Pinout

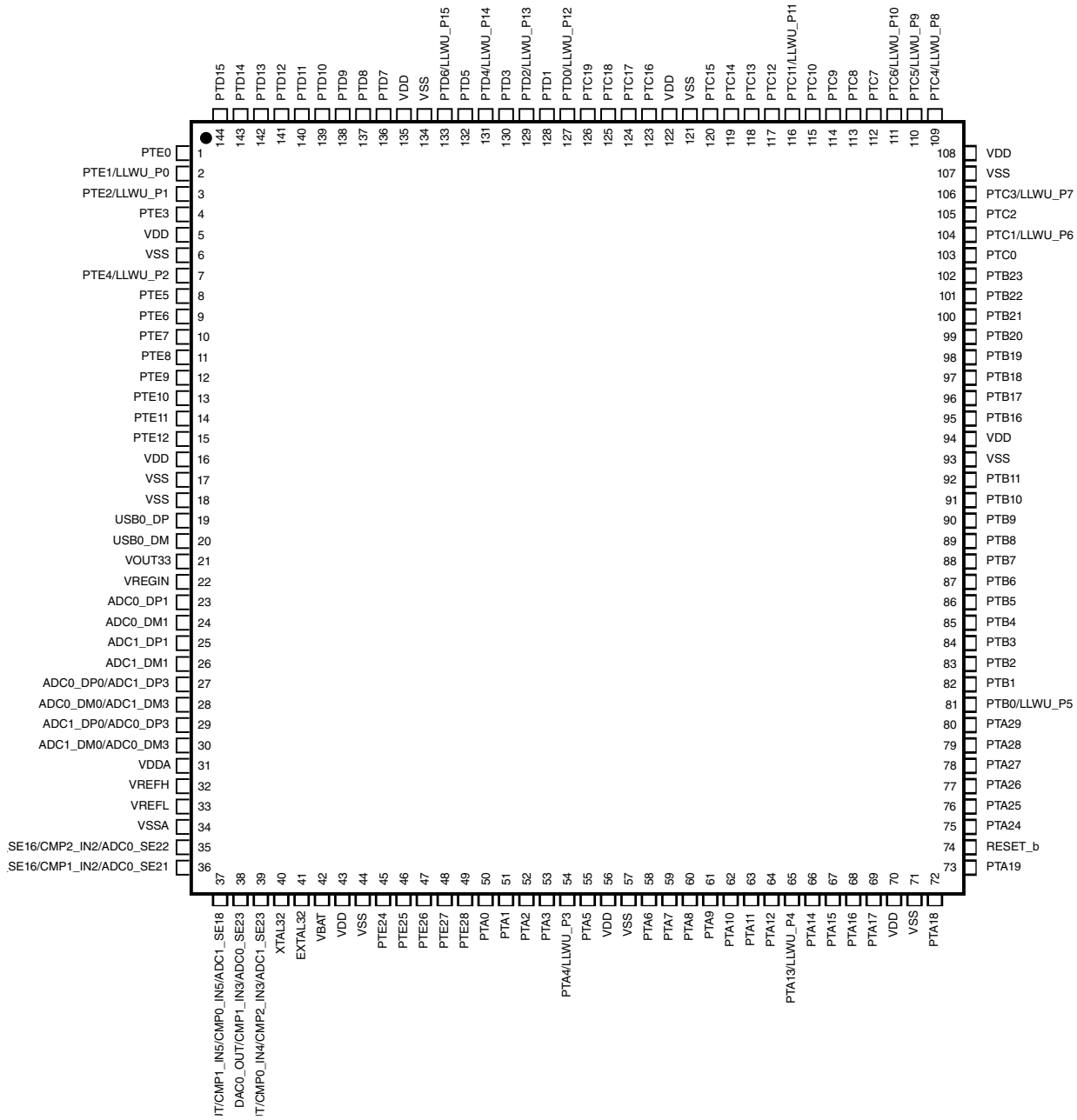

Figure 37. 144 LQFP Pinout Diagram

	1	2	3	4	5	6	7	8	9	10	11	12	
A	PTD7	PTD6/ LLWU_P15	PTD5	PTD4/ LLWU_P14	PTD0/ LLWU_P12	PTC16	PTC12	PTC8	PTC4/ LLWU_P8	NC	PTC3/ LLWU_P7	PTC2	A
B	PTD12	PTD11	PTD10	PTD3	PTC19	PTC15	PTC11/ LLWU_P11	PTC7	PTD9	NC	PTC1/ LLWU_P6	PTC0	B
C	PTD15	PTD14	PTD13	PTD2/ LLWU_P13	PTC18	PTC14	PTC10	PTC6/ LLWU_P10	PTD8	NC	PTB23	PTB22	C
D	PTE2/ LLWU_P1	PTE1/ LLWU_P0	PTE0	PTD1	PTC17	PTC13	PTC9	PTC5/ LLWU_P9	PTB21	PTB20	PTB19	PTB18	D
E	PTE6	PTE5	PTE4/ LLWU_P2	PTE3	VDD	VDD	VDD	VDD	PTB17	PTB16	PTB11	PTB10	E
F	PTE10	PTE9	PTE8	PTE7	VDD	VSS	VSS	VDD	PTB9	PTB8	PTB7	PTB6	F
G	VOUT33	VREGIN	PTE12	PTE11	VREFH	VREFL	VSS	VSS	PTB5	PTB4	PTB3	PTB2	G
H	USB0_DP	USB0_DM	VSS	PTE28	VDDA	VSSA	VSS	VSS	PTB1	PTB0/ LLWU_P5	PTA29	PTA28	H
J	ADC0_DP1	ADC0_DM1	ADC0_SE16/ CMP1_IN2/ ADC0_SE21	PTE27	PTA0	PTA1	PTA6	PTA7	PTA13/ LLWU_P4	PTA27	PTA26	PTA25	J
K	ADC1_DP1	ADC1_DM1	ADC1_SE16/ CMP2_IN2/ ADC0_SE22	PTE26	PTE25	PTA2	PTA3	PTA8	PTA12	PTA16	PTA17	PTA24	K
L	ADC0_DP0/ ADC1_DP3	ADC0_DM0/ ADC1_DM3	DAC0_OUT/ CMP1_IN3/ ADC0_SE23	DAC1_OUT/ CMP0_IN4/ CMP2_IN3/ ADC1_SE23	RTC_ WAKEUP_B	VBAT	PTA4/ LLWU_P3	PTA9	PTA11	PTA14	PTA15	RESET_b	L
M	ADC1_DP0/ ADC0_DP3	ADC1_DM0/ ADC0_DM3	VREF_OUT/ CMP1_IN5/ CMP0_IN5/ ADC1_SE18	PTE24	NC	EXTAL32	XTAL32	PTA5	PTA10	VSS	PTA19	PTA18	M
	1	2	3	4	5	6	7	8	9	10	11	12	

Figure 38. 144 MAPBGA Pinout Diagram

# Pinout

	1	2	3	4	5	6	7	8	9	10	11	
A	PTD7	PTD5	PTD4/ LLWU_P14	PTC19	PTC14	PTC13	PTC8	PTC4/ LLWU_P8	PTD9	PTD8	NC	A
B	PTD10	PTD6/ LLWU_P15	PTD3	PTC18	PTC15	PTC12	PTC7	PTC3/ LLWU_P7	PTC0	PTB16	PTB12	B
C	PTD12	PTD11	PTD2/ LLWU_P13	PTC17	PTC11/ LLWU_P11	PTC10	PTC6/ LLWU_P10	PTC2	PTB19	PTB11	PTB13	C
D	PTD14	PTD13	PTD1	PTD0/ LLWU_P12	PTC16	PTC9	PTC5/ LLWU_P9	PTC1/ LLWU_P6	PTB18	PTB10	PTB8	D
E	PTD15	PTE2/ LLWU_P1	PTE1/ LLWU_P0	PTE0	VDD	VDD	VDD	PTB23	PTB17	PTB9	PTB7	E
F	USB0_DP	USB0_DM	PTE6	PTE3	VDDA	VSSA	VSS	PTB22	PTB21	PTB20	PTB6	F
G	VOUT33	VREGIN	VSS	PTE5	VREFH	VREFL	VSS	PTB3	PTB2	PTB1	PTB0/ LLWU_P5	G
H	ADC0_DP1	ADC0_DM1	ADC0_SE16/ CMP1_IN2/ ADC0_SE21	NC	PTE24	PTE26	PTE4/ LLWU_P2	PTA1	PTA3	PTA17	PTA29	H
J	ADC1_DP1	ADC1_DM1	ADC1_SE16/ CMP2_IN2/ ADC0_SE22	PTA11	PTE25	PTA0	PTA2	PTA4/ LLWU_P3	PTA10	PTA16	RESET_b	J
K	ADC0_DP0/ ADC1_DP3	ADC0_DM0/ ADC1_DM3	NC	DAC1_OUT/ CMP0_IN4/ CMP2_IN3/ ADC1_SE23	DAC0_OUT/ CMP1_IN3/ ADC0_SE23	VBAT	PTA5	PTA12	PTA14	VSS	PTA19	K
L	ADC1_DP0/ ADC0_DP3	ADC1_DM0/ ADC0_DM3	VREF_OUT/ CMP1_IN5/ CMP0_IN5/ ADC1_SE18	XTAL32	EXTAL32	VSS	RTC_ WAKEUP_B	PTA13/ LLWU_P4	PTA15	VDD	PTA18	L
	1	2	3	4	5	6	7	8	9	10	11	

**Figure 39. 121 XFBGA Pinout Diagram**

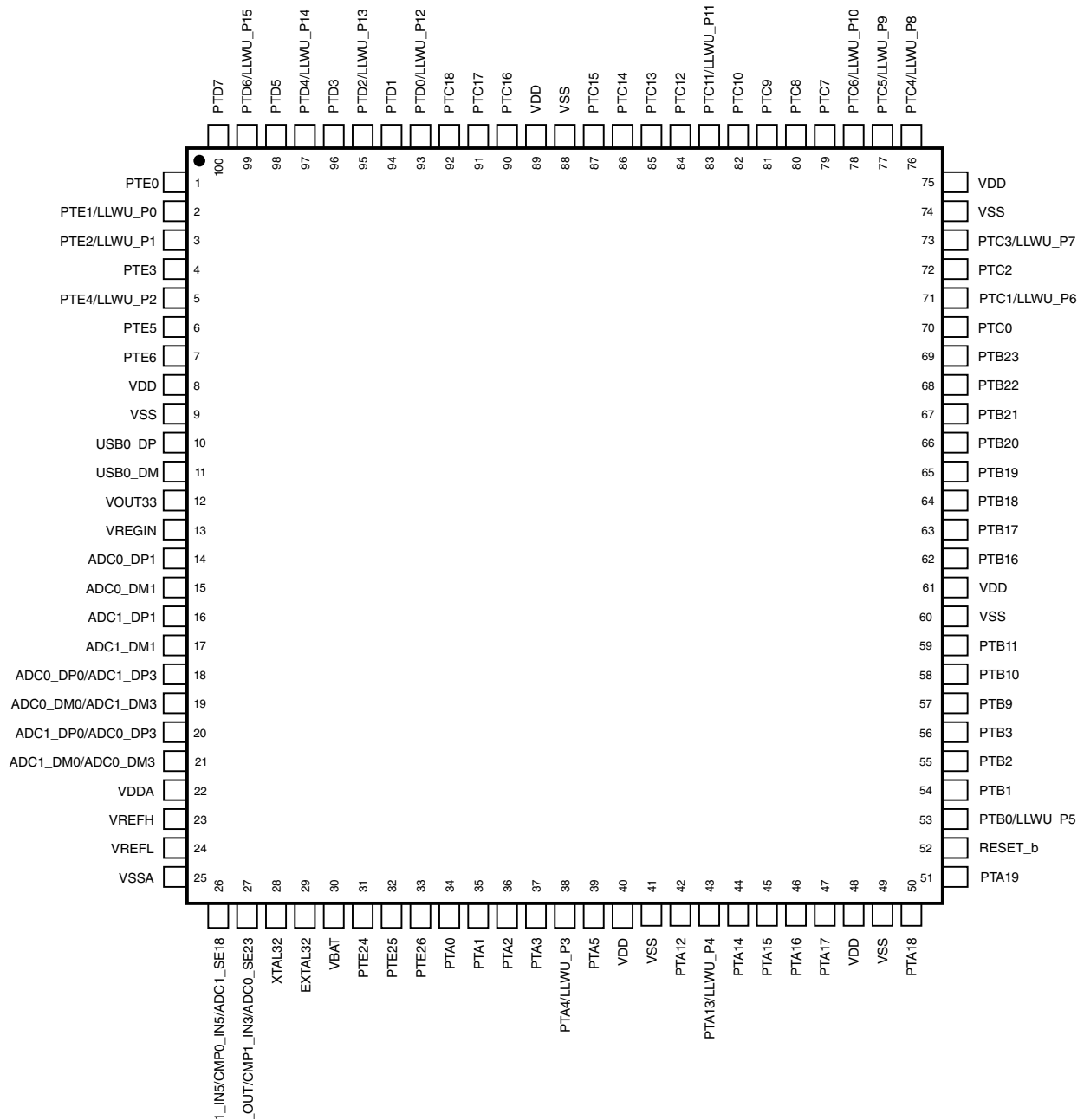

Figure 40. 100 LQFP Pinout Diagram

## 6 Ordering parts

## 6.1 Determining valid orderable parts

Valid orderable part numbers are provided on the web. To determine the orderable part numbers for this device, go to [nxp.com](http://nxp.com) and perform a part number search for the following device numbers: MK64

## 7 Part identification

### 7.1 Description

Part numbers for the chip have fields that identify the specific part. You can use the values of these fields to determine the specific part you have received.

### 7.2 Format

Part numbers for this device have the following format:

Q K## A M FFF R T PP CC N

### 7.3 Fields

This table lists the possible values for each field in the part number (not all combinations are valid):

Field	Description	Values
Q	Qualification status	<ul style="list-style-type: none"> <li>M = Fully qualified, general market flow</li> <li>P = Prequalification</li> </ul>
K##	Kinetis family	<ul style="list-style-type: none"> <li>K64 = Ethernet with high RAM density</li> </ul>
A	Key attribute	<ul style="list-style-type: none"> <li>D = Cortex-M4 w/ DSP</li> <li>F = Cortex-M4 w/ DSP and FPU</li> </ul>
M	Flash memory type	<ul style="list-style-type: none"> <li>N = Program flash only</li> <li>X = Program flash and FlexMemory</li> </ul>
FFF	Program flash memory size	<ul style="list-style-type: none"> <li>32 = 32 KB</li> <li>64 = 64 KB</li> <li>128 = 128 KB</li> <li>256 = 256 KB</li> <li>512 = 512 KB</li> <li>1M0 = 1 MB</li> <li>2M0 = 2 MB</li> </ul>

*Table continues on the next page...*



Field	Description	Values
R	Silicon revision	<ul style="list-style-type: none"> <li>• Z = Initial</li> <li>• (Blank) = Main</li> <li>• A = Revision after main</li> </ul>
T	Temperature range (°C)	<ul style="list-style-type: none"> <li>• V = -40 to 105</li> <li>• C = -40 to 85</li> </ul>
PP	Package identifier	<ul style="list-style-type: none"> <li>• FM = 32 QFN (5 mm x 5 mm)</li> <li>• FT = 48 QFN (7 mm x 7 mm)</li> <li>• LF = 48 LQFP (7 mm x 7 mm)</li> <li>• LH = 64 LQFP (10 mm x 10 mm)</li> <li>• MP = 64 MAPBGA (5 mm x 5 mm)</li> <li>• LK = 80 LQFP (12 mm x 12 mm)</li> <li>• LL = 100 LQFP (14 mm x 14 mm)</li> <li>• MC = 121 MAPBGA (8 mm x 8 mm)</li> <li>• DC = 121 XFBGA (8 mm x 8 mm x 0.5 mm)</li> <li>• LQ = 144 LQFP (20 mm x 20 mm)</li> <li>• MD = 144 MAPBGA (13 mm x 13 mm)</li> </ul>
CC	Maximum CPU frequency (MHz)	<ul style="list-style-type: none"> <li>• 5 = 50 MHz</li> <li>• 7 = 72 MHz</li> <li>• 10 = 100 MHz</li> <li>• 12 = 120 MHz</li> <li>• 15 = 150 MHz</li> <li>• 16 = 168 MHz</li> <li>• 18 = 180 MHz</li> </ul>
N	Packaging type	<ul style="list-style-type: none"> <li>• R = Tape and reel</li> <li>• (Blank) = Trays</li> </ul>

## 7.4 Example

This is an example part number:

MK64FN1M0VMD12

## 8 Terminology and guidelines

### 8.1 Definitions

Key terms are defined in the following table:

Term	Definition
Rating	A minimum or maximum value of a technical characteristic that, if exceeded, may cause permanent chip failure:

*Table continues on the next page...*

## Terminology and guidelines

Term	Definition
	<ul style="list-style-type: none"> <li>• <i>Operating ratings</i> apply during operation of the chip.</li> <li>• <i>Handling ratings</i> apply when the chip is not powered.</li> </ul> <p><b>NOTE:</b> The likelihood of permanent chip failure increases rapidly as soon as a characteristic begins to exceed one of its operating ratings.</p>
Operating requirement	A specified value or range of values for a technical characteristic that you must guarantee during operation to avoid incorrect operation and possibly decreasing the useful life of the chip
Operating behavior	A specified value or range of values for a technical characteristic that are guaranteed during operation if you meet the operating requirements and any other specified conditions
Typical value	<p>A specified value for a technical characteristic that:</p> <ul style="list-style-type: none"> <li>• Lies within the range of values specified by the operating behavior</li> <li>• Is representative of that characteristic during operation when you meet the <a href="#">typical-value conditions</a> or other specified conditions</li> </ul> <p><b>NOTE:</b> Typical values are provided as design guidelines and are neither tested nor guaranteed.</p>

## 8.2 Examples

*Operating rating:*

Symbol	Description	Min.	Max.	Unit
V <sub>DD</sub>	1.0 V core supply voltage	-0.3	1.2	V

*Operating requirement:*

Symbol	Description	Min.	Max.	Unit
V <sub>DD</sub>	1.0 V core supply voltage	0.9	1.1	V

*Operating behavior that includes a typical value:*

Symbol	Description	Min.	Typ.	Max.	Unit
I <sub>WP</sub>	Digital I/O weak pullup/pulldown current	10	70	130	μA

### 8.3 Typical-value conditions

Typical values assume you meet the following conditions (or other conditions as specified):

Symbol	Description	Value	Unit
$T_A$	Ambient temperature	25	°C
$V_{DD}$	Supply voltage	3.3	V

### 8.4 Relationship between ratings and operating requirements

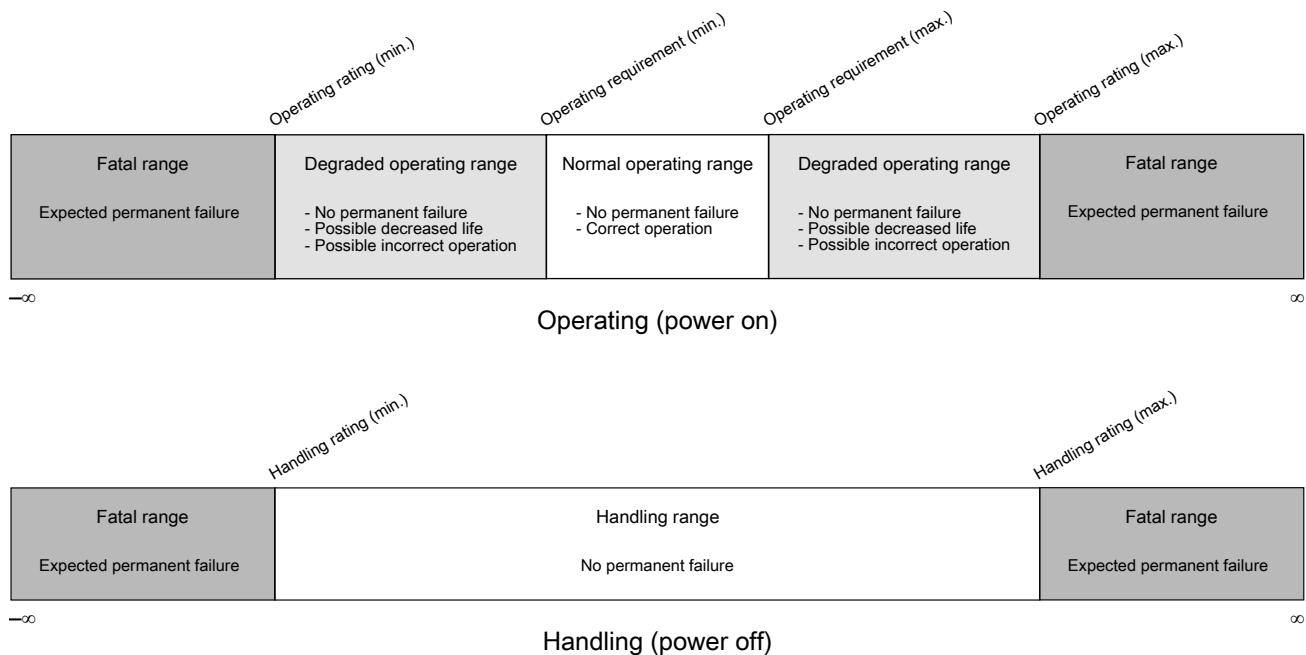

### 8.5 Guidelines for ratings and operating requirements

Follow these guidelines for ratings and operating requirements:

- Never exceed any of the chip's ratings.
- During normal operation, don't exceed any of the chip's operating requirements.
- If you must exceed an operating requirement at times other than during normal operation (for example, during power sequencing), limit the duration as much as possible.

## 9 Revision History

The following table provides a revision history for this document.

**Table 58. Revision History**

Rev. No.	Date	Substantial Changes
2	01/2014	Initial public release.
3	04/2014	<ul style="list-style-type: none"> <li>• Format changes</li> <li>• Updated Table 23 "Flash command timing specifications."</li> </ul>
4	09/2014	<ul style="list-style-type: none"> <li>• Updated Table 6 "Power consumption operating behavior."</li> <li>• Updated Table 17 "IRC48M specifications"</li> <li>• Updated Table 35 "VREF full-range operating behavior"</li> </ul>
5	12/2014	<ul style="list-style-type: none"> <li>• Updated Table 6 "Power consumption operating behavior."</li> <li>• Added a note to the section "Power consumption operating behaviors."</li> </ul>
6	08/2015	<ul style="list-style-type: none"> <li>• Added a footnote to the maximum SCL clock frequency value in the table "I<sup>2</sup>C timing"</li> <li>• Changed the title of the table "I<sup>2</sup>C 1 MHZ timing" to "I<sup>2</sup>C 1 Mbps timing"</li> <li>• Added a footnote and updated the table "IRC48M specifications" for open loop total deviation of IRC48M frequency at high voltage and low voltage.</li> <li>• Added a footnote on the ambient temperature entry to the section "Thermal operating requirements."</li> <li>• Added a note to the section "Power consumption operating behaviors" and updated values in the table "Power consumption operating behaviors."</li> <li>• Added a note to the maximum frequency value in the table "Slave mode DSPI timing (limited voltage range)."</li> <li>• Redeveloped the section "Terminology and guidelines."</li> </ul>
7	10/2016	<ul style="list-style-type: none"> <li>• Updated the values of I<sub>DD_STOP</sub> and I<sub>DD_VLLS0</sub> in the table "Power consumption operating behaviors"</li> </ul>

**How to Reach Us:**

**Home Page:**

[nxp.com](http://nxp.com)

**Web Support:**

[nxp.com/support](http://nxp.com/support)

Information in this document is provided solely to enable system and software implementers to use NXP products. There are no express or implied copyright licenses granted hereunder to design or fabricate any integrated circuits based on the information in this document. NXP reserves the right to make changes without further notice to any products herein.

NXP makes no warranty, representation, or guarantee regarding the suitability of its products for any particular purpose, nor does NXP assume any liability arising out of the application or use of any product or circuit, and specifically disclaims any and all liability, including without limitation consequential or incidental damages. "Typical" parameters that may be provided in NXP data sheets and/or specifications can and do vary in different applications, and actual performance may vary over time. All operating parameters, including "typicals," must be validated for each customer application by customer's technical experts. NXP does not convey any license under its patent rights nor the rights of others. NXP sells products pursuant to standard terms and conditions of sale, which can be found at the following address: [nxp.com/salestermsandconditions](http://nxp.com/salestermsandconditions).

NXP, NXP logo, and Kinetis are trademarks of NXP B.V. All other product or service names are the property of their respective owners. ARM and Cortex are registered trademarks of ARM Limited (or its subsidiaries) in the EU and/or elsewhere. The USB-IF Logo is a registered trademark of USB Implementers Forum, Inc. All rights reserved.

©2014–2016 NXP B.V.

Document Number K64P144M120SF5  
Revision 7, 11/2016





## Стандарт Электрон Связь

Мы молодая и активно развивающаяся компания в области поставок электронных компонентов. Мы поставляем электронные компоненты отечественного и импортного производства напрямую от производителей и с крупнейших складов мира.

Благодаря сотрудничеству с мировыми поставщиками мы осуществляем комплексные и плановые поставки широчайшего спектра электронных компонентов.

Собственная эффективная логистика и склад в обеспечивает надежную поставку продукции в точно указанные сроки по всей России.

Мы осуществляем техническую поддержку нашим клиентам и предпродажную проверку качества продукции. На все поставляемые продукты мы предоставляем гарантию .

Осуществляем поставки продукции под контролем ВП МО РФ на предприятия военно-промышленного комплекса России , а также работаем в рамках 275 ФЗ с открытием отдельных счетов в уполномоченном банке. Система менеджмента качества компании соответствует требованиям ГОСТ ISO 9001.

Минимальные сроки поставки, гибкие цены, неограниченный ассортимент и индивидуальный подход к клиентам являются основой для выстраивания долгосрочного и эффективного сотрудничества с предприятиями радиоэлектронной промышленности, предприятиями ВПК и научно-исследовательскими институтами России.

С нами вы становитесь еще успешнее!

### Наши контакты:

**Телефон:** +7 812 627 14 35

**Электронная почта:** [sales@st-electron.ru](mailto:sales@st-electron.ru)

**Адрес:** 198099, Санкт-Петербург,  
Промышленная ул, дом № 19, литера Н,  
помещение 100-Н Офис 331