



MCP9800
Temperature Sensor
Demo Board
User's Guide

Note the following details of the code protection feature on Microchip devices:

- Microchip products meet the specification contained in their particular Microchip Data Sheet.
- Microchip believes that its family of products is one of the most secure families of its kind on the market today, when used in the intended manner and under normal conditions.
- There are dishonest and possibly illegal methods used to breach the code protection feature. All of these methods, to our knowledge, require using the Microchip products in a manner outside the operating specifications contained in Microchip's Data Sheets. Most likely, the person doing so is engaged in theft of intellectual property.
- Microchip is willing to work with the customer who is concerned about the integrity of their code.
- Neither Microchip nor any other semiconductor manufacturer can guarantee the security of their code. Code protection does not mean that we are guaranteeing the product as "unbreakable."

Code protection is constantly evolving. We at Microchip are committed to continuously improving the code protection features of our products. Attempts to break Microchip's code protection feature may be a violation of the Digital Millennium Copyright Act. If such acts allow unauthorized access to your software or other copyrighted work, you may have a right to sue for relief under that Act.

Information contained in this publication regarding device applications and the like is provided only for your convenience and may be superseded by updates. It is your responsibility to ensure that your application meets with your specifications. MICROCHIP MAKES NO REPRESENTATIONS OR WARRANTIES OF ANY KIND WHETHER EXPRESS OR IMPLIED, WRITTEN OR ORAL, STATUTORY OR OTHERWISE, RELATED TO THE INFORMATION, INCLUDING BUT NOT LIMITED TO ITS CONDITION, QUALITY, PERFORMANCE, MERCHANTABILITY OR FITNESS FOR PURPOSE. Microchip disclaims all liability arising from this information and its use. Use of Microchip devices in life support and/or safety applications is entirely at the buyer's risk, and the buyer agrees to defend, indemnify and hold harmless Microchip from any and all damages, claims, suits, or expenses resulting from such use. No licenses are conveyed, implicitly or otherwise, under any Microchip intellectual property rights.

Trademarks

The Microchip name and logo, the Microchip logo, Accuron, dsPIC, KEELOQ, KEELOQ logo, MPLAB, PIC, PICmicro, PICSTART, rPIC and SmartShunt are registered trademarks of Microchip Technology Incorporated in the U.S.A. and other countries.

FilterLab, Linear Active Thermistor, MXDEV, MXLAB, SEEVAL, SmartSensor and The Embedded Control Solutions Company are registered trademarks of Microchip Technology Incorporated in the U.S.A.

Analog-for-the-Digital Age, Application Maestro, CodeGuard, dsPICDEM, dsPICDEM.net, dsPICworks, dsSPEAK, ECAN, ECONOMONITOR, FanSense, In-Circuit Serial Programming, ICSP, ICEPIC, Mindi, MiWi, MPASM, MPLAB Certified logo, MPLIB, MPLINK, mTouch, PICkit, PICDEM, PICDEM.net, PICtail, PIC³² logo, PowerCal, PowerInfo, PowerMate, PowerTool, REAL ICE, rLAB, Select Mode, Total Endurance, UNI/O, WiperLock and ZENA are trademarks of Microchip Technology Incorporated in the U.S.A. and other countries.

SQTP is a service mark of Microchip Technology Incorporated in the U.S.A.

All other trademarks mentioned herein are property of their respective companies.

© 2008, Microchip Technology Incorporated, Printed in the U.S.A., All Rights Reserved.

 Printed on recycled paper.

QUALITY MANAGEMENT SYSTEM
CERTIFIED BY DNV
== ISO/TS 16949:2002 ==

Microchip received ISO/TS-16949:2002 certification for its worldwide headquarters, design and wafer fabrication facilities in Chandler and Tempe, Arizona; Gresham, Oregon and design centers in California and India. The Company's quality system processes and procedures are for its PIC[®] MCUs and dsPIC[®] DSCs, KEELOQ[®] code hopping devices, Serial EEPROMs, microperipherals, nonvolatile memory and analog products. In addition, Microchip's quality system for the design and manufacture of development systems is ISO 9001:2000 certified.



MCP9800 TEMPERATURE SENSOR DEMO BOARD USER'S GUIDE

Table of Contents

Preface	1
Introduction.....	1
Document Layout	1
Conventions Used in this Guide	2
Recommended Reading.....	3
The Microchip Web Site	3
Customer Support	3
Document Revision History	3
Chapter 1. Product Overview	
1.1 Introduction	5
1.2 What is the MCP9800 Temperature Sensor Demo Board?	5
1.3 What the MCP9800 Temperature Sensor Demo Board Kit includes	5
Chapter 2. Installation and Operation	
2.1 Introduction	7
2.2 Features	7
2.3 Getting Started	8
2.4 Functional description	9
Appendix A. Schematic and Layouts	
A.1 Introduction	13
A.2 Board Schematic	14
A.3 Board - Top Layer	15
A.4 Board - Top Silk-screen Layer	15
A.5 Board - Bottom Layer	16
Appendix B. Bill Of Materials (BOM)	
Worldwide Sales and Service	20

MCP9800 Temperature Sensor Demo Board User's Guide

NOTES:



MCP9800 TEMPERATURE SENSOR DEMO BOARD USER'S GUIDE

Preface

NOTICE TO CUSTOMERS

All documentation becomes dated, and this manual is no exception. Microchip tools and documentation are constantly evolving to meet customer needs, so some actual dialogs and/or tool descriptions may differ from those in this document. Please refer to our web site (www.microchip.com) to obtain the latest documentation available.

Documents are identified with a "DS" number. This number is located on the bottom of each page, in front of the page number. The numbering convention for the DS number is "DSXXXXA", where "XXXX" is the document number and "A" is the revision level of the document.

For the most up-to-date information on development tools, see the MPLAB® IDE on-line help. Select the Help menu, and then Topics to open a list of available on-line help files.

INTRODUCTION

This chapter contains general information that will be useful to know before using the MCP9800 Temperature Sensor Demo Board. Items discussed in this chapter include:

- Document Layout
- Conventions Used in this Guide
- Recommended Reading
- The Microchip Web Site
- Customer Support
- Document Revision History

DOCUMENT LAYOUT

This document describes how to use the MCP9800 Temperature Sensor Demo Board as a development tool to emulate and debug firmware on a target board. The manual layout is as follows:

- **Chapter 1. "Product Overview"** – Important information about the MCP9800 Temperature Sensor Demo Board.
- **Chapter 2. "Installation and Operation"** – This chapter includes a detailed description of each function of the demo board and instructions for how to begin using the board.
- **Appendix A. "Schematic and Layouts"** – Shows the schematic and layout diagrams for the MCP9800 Temperature Sensor Demo Board.
- **Appendix B. "Bill Of Materials (BOM)"** – Lists the parts used to build the MCP9800 Temperature Sensor Demo Board.

MCP9800 Temperature Sensor Demo Board User's Guide

CONVENTIONS USED IN THIS GUIDE

This manual uses the following documentation conventions:

DOCUMENTATION CONVENTIONS

Description	Represents	Examples
Arial font:		
Italic characters	Referenced books	<i>MPLAB[®] IDE User's Guide</i>
	Emphasized text	...is the <i>only</i> compiler...
Initial caps	A window	the Output window
	A dialog	the Settings dialog
	A menu selection	select Enable Programmer
Quotes	A field name in a window or dialog	"Save project before build"
Underlined, italic text with right angle bracket	A menu path	<u><i>File>Save</i></u>
Bold characters	A dialog button	Click OK
	A tab	Click the Power tab
N'Rnnnn	A number in verilog format, where N is the total number of digits, R is the radix and n is a digit.	4'b0010, 2'hF1
Text in angle brackets < >	A key on the keyboard	Press <Enter>, <F1>
Courier New font:		
Plain Courier New	Sample source code	#define START
	Filenames	autoexec.bat
	File paths	c:\mcc18\h
	Keywords	_asm, _endasm, static
	Command-line options	-Opa+, -Opa-
	Bit values	0, 1
	Constants	0xFF, 'A'
Italic Courier New	A variable argument	<i>file.o</i> , where <i>file</i> can be any valid filename
Square brackets []	Optional arguments	mcc18 [options] <i>file</i> [options]
Curly brackets and pipe character: { }	Choice of mutually exclusive arguments; an OR selection	errorlevel {0 1}
Ellipses...	Replaces repeated text	var_name [, var_name...]
	Represents code supplied by user	void main (void) { ... }

RECOMMENDED READING

This user's guide describes how to use MCP9800 Temperature Sensor Demo Board. Other useful documents are listed below. The following Microchip documents are available and recommended as supplemental reference resources.

MCP9800/1/2/3 Data Sheet, “2-Wire High-Accuracy Temperature Sensor”, DS21909

This data sheet provides detailed information regarding the MCP9800 device.

THE MICROCHIP WEB SITE

Microchip provides online support via our web site at www.microchip.com. This web site is used as a means to make files and information easily available to customers. Accessible by using your favorite Internet browser, the web site contains the following information:

- **Product Support** – Data sheets and errata, application notes and sample programs, design resources, user's guides and hardware support documents, latest software releases and archived software
- **General Technical Support** – Frequently Asked Questions (FAQs), technical support requests, online discussion groups, Microchip consultant program member listing
- **Business of Microchip** – Product selector and ordering guides, latest Microchip press releases, listing of seminars and events, listings of Microchip sales offices, distributors and factory representatives

CUSTOMER SUPPORT

Users of Microchip products can receive assistance through several channels:

- Distributor or Representative
- Local Sales Office
- Field Application Engineer (FAE)
- Technical Support

Customers should contact their distributor, representative or field application engineer (FAE) for support. Local sales offices are also available to help customers. A listing of sales offices and locations is included in the back of this document.

Technical support is available through the web site at: <http://support.microchip.com>

DOCUMENT REVISION HISTORY

Revision A (August 2008)

- Initial Release of this Document.

MCP9800 Temperature Sensor Demo Board User's Guide

NOTES:



MCP9800 TEMPERATURE SENSOR DEMO BOARD USER'S GUIDE

Chapter 1. Product Overview

1.1 INTRODUCTION

This chapter provides an overview of the MCP9800 Temperature Sensor Demo Board and covers the following topics:

- What is the MCP9800 Temperature Sensor Demo Board?
- What the MCP9800 Temperature Sensor Demo Board kit includes

1.2 WHAT IS THE MCP9800 TEMPERATURE SENSOR DEMO BOARD?

The MCP9800 Temperature Sensor Demo Board demonstrates the sensor's features. Users can connect the demo board to a PC with USB interface and evaluate the sensor performance. The 7-Segment LED displays temperature in degrees Celsius or degrees Fahrenheit; the temperature alert feature can be set by the users using an on board potentiometer. An alert LED is used to indicate an over temperature condition.

In addition, temperature can be datalogged using the Microchip Thermal Management Software Graphical User Interface (GUI). The sensor registers can also be programmed using the GUI.

1.3 WHAT THE MCP9800 TEMPERATURE SENSOR DEMO BOARD KIT INCLUDES

This MCP9800 Temperature Sensor Demo Board Kit includes:

- MCP9800 Temperature Sensor Demo Board (102-0170)
- Microchip Thermal Management Graphical User Interface (GUI)
- Analog and Interface Products Demonstration Boards CD-ROM (DS21912)
 - MCP9800 Temperature Sensor Demo Board User's Guide (DS51758)
 - MCP9800/1/2/3 Data Sheet, "2-Wire High-Accuracy Temperature Sensor", (DS21909)

MCP9800 Temperature Sensor Demo Board User's Guide

NOTES:



MCP9800 TEMPERATURE SENSOR DEMO BOARD USER'S GUIDE

Chapter 2. Installation and Operation

2.1 INTRODUCTION

The MCP9800 Temperature Sensor Demo Board demonstrates the sensor functions and features. This demo board is powered from a USB port and it displays temperature on a 7-Segment LED display. A push button switch is used to display temperature in degrees F or degrees C. In addition, the sensor overtemperature alert feature can be evaluated by the user using a rotary potentiometer. The temperature Alert and Hysteresis registers are programmed to a preset temperature limit based on the potentiometer wiper position. An LED is used to indicate overtemperature condition.

In addition, temperature can be data logged using the Microchip Thermal Management Software Graphical User Interface (GUI). The sensor registers can also be programmed using the GUI.

2.2 FEATURES

The MCP9800 Temperature Sensor Demo Board has the following features:

- Graphical User Interface which can be used for temperature data logging
- Small PCB layout
- Standard 100 mil 14-pin header (P1) for easy interface to PICkit™ 1 Flash Starter Kit or custom application
- 7-segment LED display to display temperature in °C or in °F
- Temperature Alert Programability
- Temperature Alert indicating LED

MCP9800 Temperature Sensor Demo Board User's Guide

2.3 GETTING STARTED

This section describes how to quickly configure the MCP9800 Temperature Sensor Demo Board and PICkit™ 1 Flash Starter Kit. A block diagram of the configuration is provided in Figure 2-1.

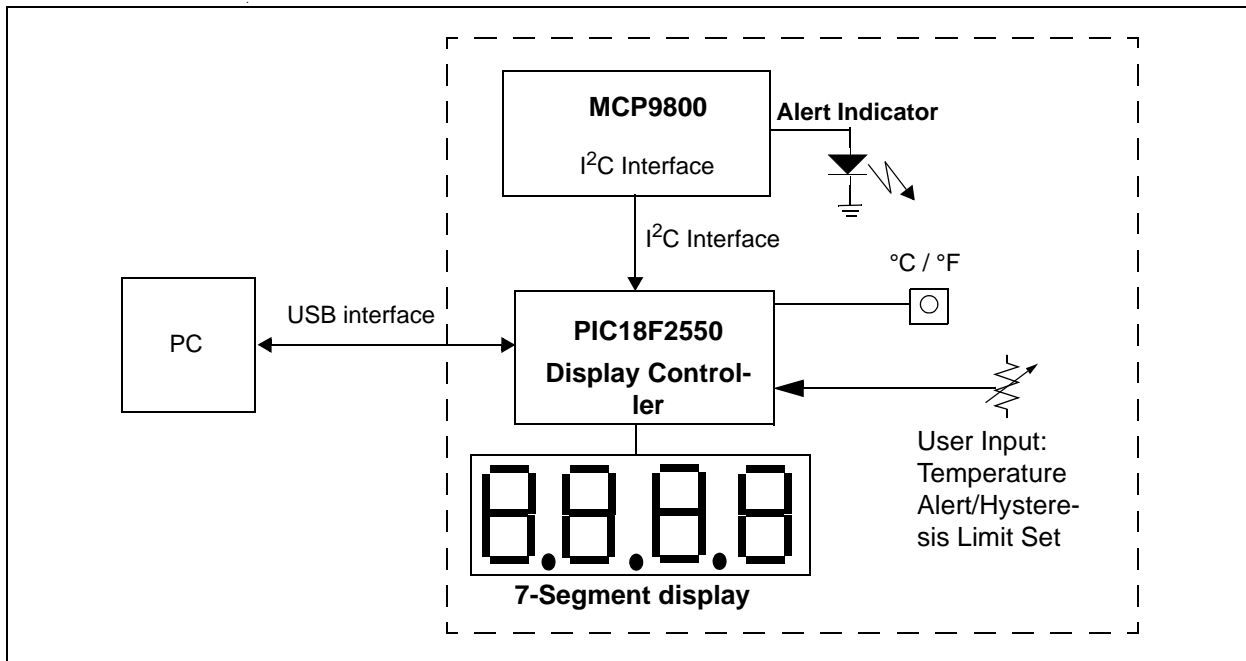

FIGURE 2-1: MCP9800 Temperature Sensor Demo Board Block Diagram.

2.3.1 Hardware Setup

1. The MCP9800 Temperature Sensor Demo Board has a mini-USB connector for a PC interface. Connect the USB cable from the demo board to a PC. Temperature should be displayed on the 7-Segment LED display.
2. Start the Thermal Management Software GUI for data logging or to evaluate the sensor features.

2.4 FUNCTIONAL DESCRIPTION

2.4.1 The MCP9800 Temperature Sensor Demo Board

The MCP9800 Temperature Sensor Demo Board has the MCP9800 temperature sensor device, a 7-segment LED display circuit, and a PIC18F2550 Microcontroller which controls the sensor and PC interface via USB. The controller communicates with the sensor and displays the temperature on the 7-segment LED display. The PIC also monitors user inputs via a push button switch and a potentiometer, and controls the sensor and the 7-segment display accordingly. In addition, the PIC supports a full speed USB protocol which is used to interface with a PC and provide additional user interface to access all sensor features, such as temperature measurement resolution, measurement queue, shutdown/oneshot mode, and temperature alert output polarity. The software can also be used to data log temperature data.

2.4.2 The MCP9800

The MCP9800 comes with user-programmable registers that provide flexibility for temperature sensing applications. The register settings allow user selectable 9-bit to 12-bit temperature measurement resolution, configuration of the power-saving Shutdown and One-shot (single conversion on command while in the Shutdown) modes and the specification of both temperature alert output and hysteresis limits. When the temperature changes beyond the specified limits, the MCP9800 device outputs an alert signal. The user has the option of setting the alert output signal polarity as an active-low or active-high comparator output for thermostat operation, or as temperature event interrupt output for microprocessor-based systems.

This device has I²C/SMBus compatible serial interface (refer to the MCP9800/1/2/3 Data Sheet, DS21909, for further details).

2.4.3 User Selectable Features

The demo firmware programs the temperature limit and hysteresis limit registers (TSET and THYST) according to the position of the RP1 potentiometer. The potentiometer is connected to the PIC18F2550 analog input pin. The voltage across the potentiometer wiper terminal determines the T_{SET} limit and T_{HYST} register settings. Table 2-1 shows RP1 wiper voltage and the corresponding T_{SET} limit with 5°C hysteresis.

When the ambient temperature exceeds the programmed T_{SET} limit, the MCP9800 outputs an Alert signal using the ALERT output pin. This pin is an open-drain output pin which is configured as an active-high output. When this pin is high, the D1 diode lits up, and it remains lit up until the temperature drifts beyond the hysteresis limit, T_{HYST}.

This firmware also converts the degree Celsius to degree Fahrenheit using the SW1 switch. When user presses the momentary push-button switch, the 7-segment display shows the ambient temperature in degree Fahrenheit/Celsius.

In addition, the user has the option of changing the MCP9800 temperature measurement resolution (default resolution is 12-bit). However, this requires the GUI.

MCP9800 Temperature Sensor Demo Board User's Guide

TABLE 2-1: POTENTIOMETER WIPER POSITION AND T_{SET} SETTING

VR1 Position	T _{SET} (°C)	T _{Hyst} (°C)
V _{DD} /15	10	9
V _{DD} /14	13	12
V _{DD} /13	16	15
V _{DD} /12	19	18
V _{DD} /11	22	21
V _{DD} /10	25	24
V _{DD} /9	28	27
V _{DD} /8	31	30
V _{DD} /7	34	33
V _{DD} /6	37	36
V _{DD} /5	40	39
V _{DD} /4	43	42
V _{DD} /3	46	45
V _{DD} /2	49	48
V _{DD} /1	52	51
V _{DD}	55	54

2.4.4 Microchip Thermal Management GUI

The Microchip Thermal Management Graphical User Interface is an easy to use software tool which allows the users to evaluate the demo board and sensor features, as displayed in Figure 2-2.

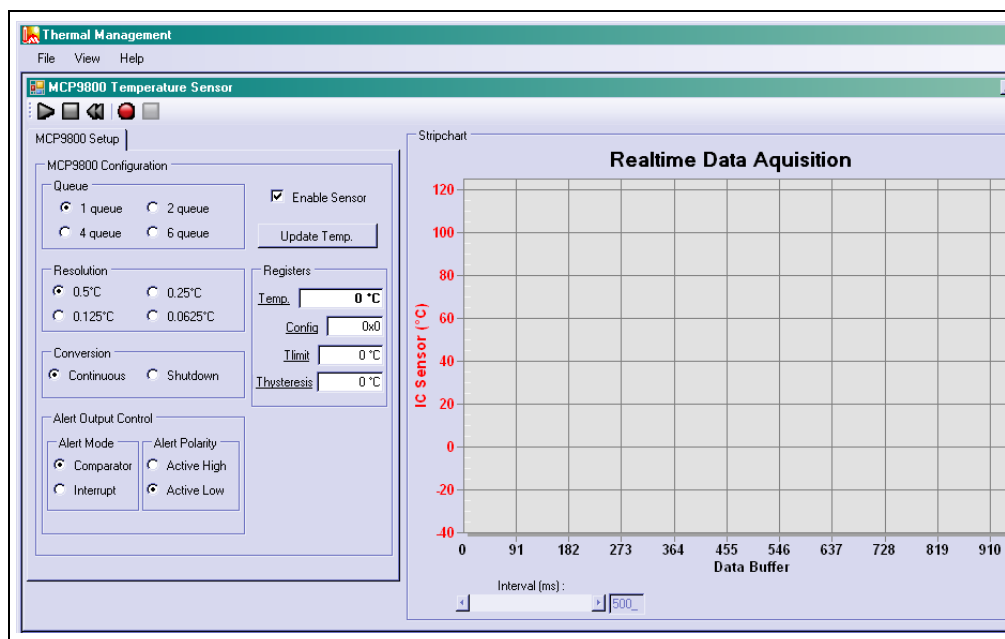

FIGURE 2-2: Microchip Thermal Management GUI.

Once the hardware is connected, the software recognizes the device ID and displays the corresponding GUI for the demo board. This tool enables the user to evaluate the sensor's features and perform temperature datalog. The black "Play", "Stop", and "Reset" icons can be used to perform continuous datalog. And the red "Record" icon enables the user to datalog to an external file. The logging interval can be adjusted using the Interval Scroll bar from 100 ms to 1000 ms.

The Real-time Data Acquisition charting tool can be customized by double clicking the chart, as shown in Figure 2-3. Additional options are available by right clicking the chart. Users can also zoom into a specific plot range by clicking and dragging the section.

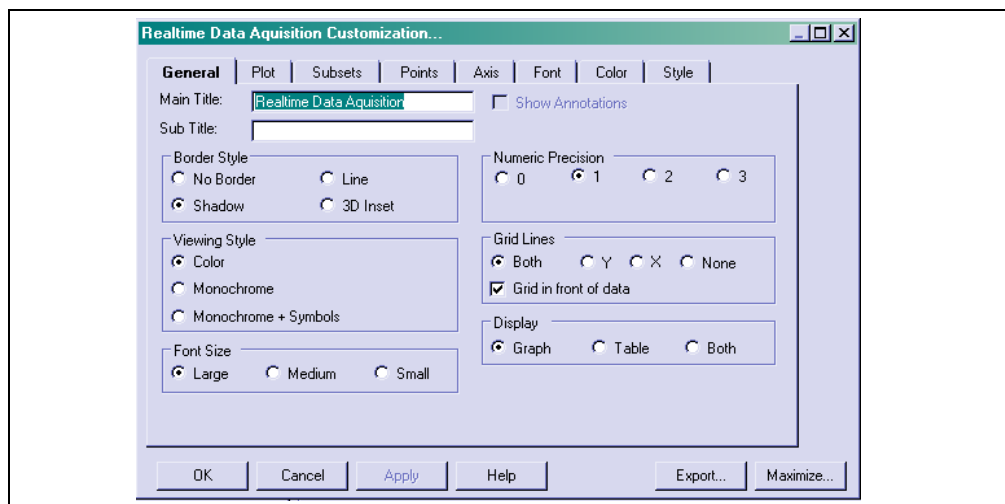

FIGURE 2-3: Chart Setup Options.

MCP9800 Temperature Sensor Demo Board User's Guide

NOTES:



MCP9800 TEMPERATURE SENSOR DEMO BOARD USER'S GUIDE

Appendix A. Schematic and Layouts

A.1 INTRODUCTION

This appendix contains the following schematics and layouts for the MCP9800 Temperature Sensor Demo Board:

- Board Schematic
- Board - Top Layer
- Board - Top Silk-screen Layer
- Board - Bottom Layer

MCP9800 Temperature Sensor Demo Board User's Guide

A.2 BOARD SCHEMATIC

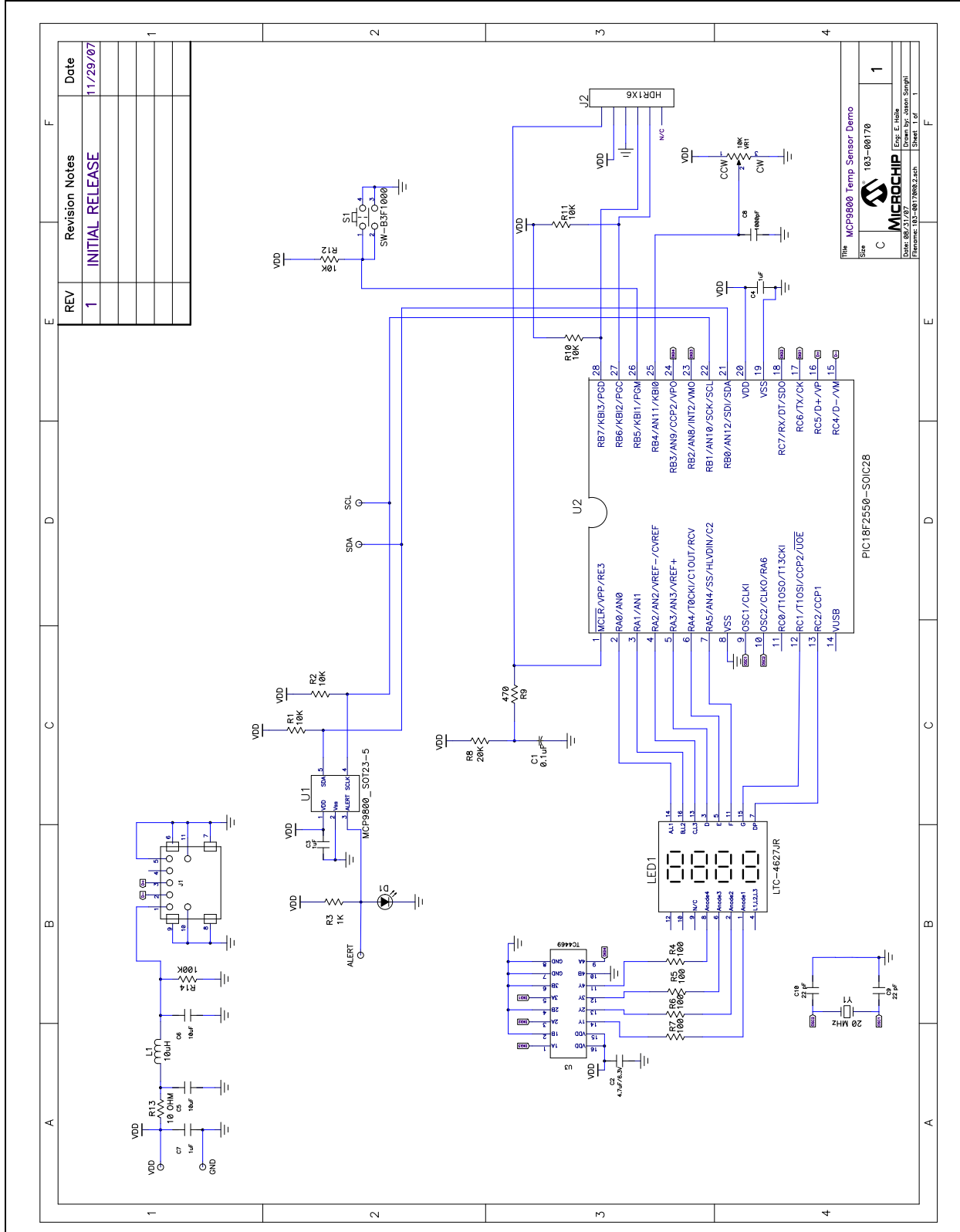

A.3 BOARD - TOP LAYER

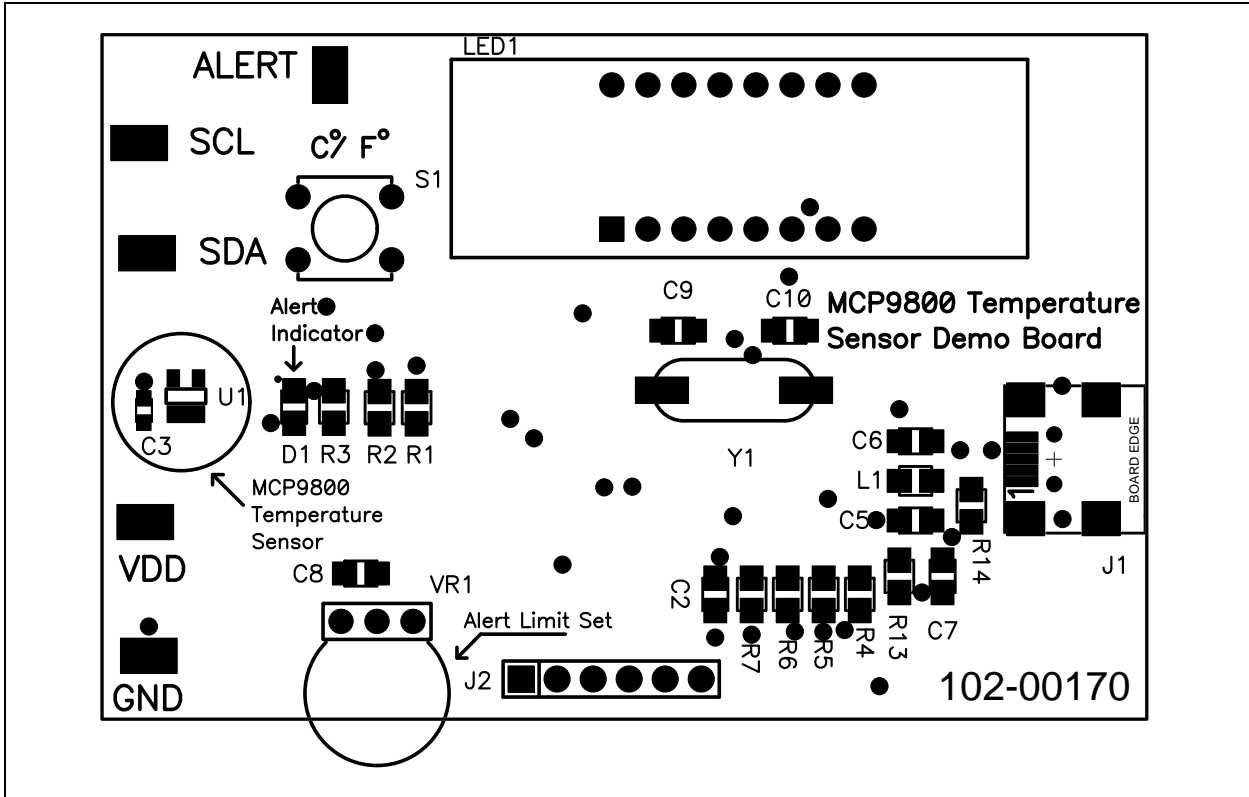

A.4 BOARD - TOP SILK-SCREEN LAYER

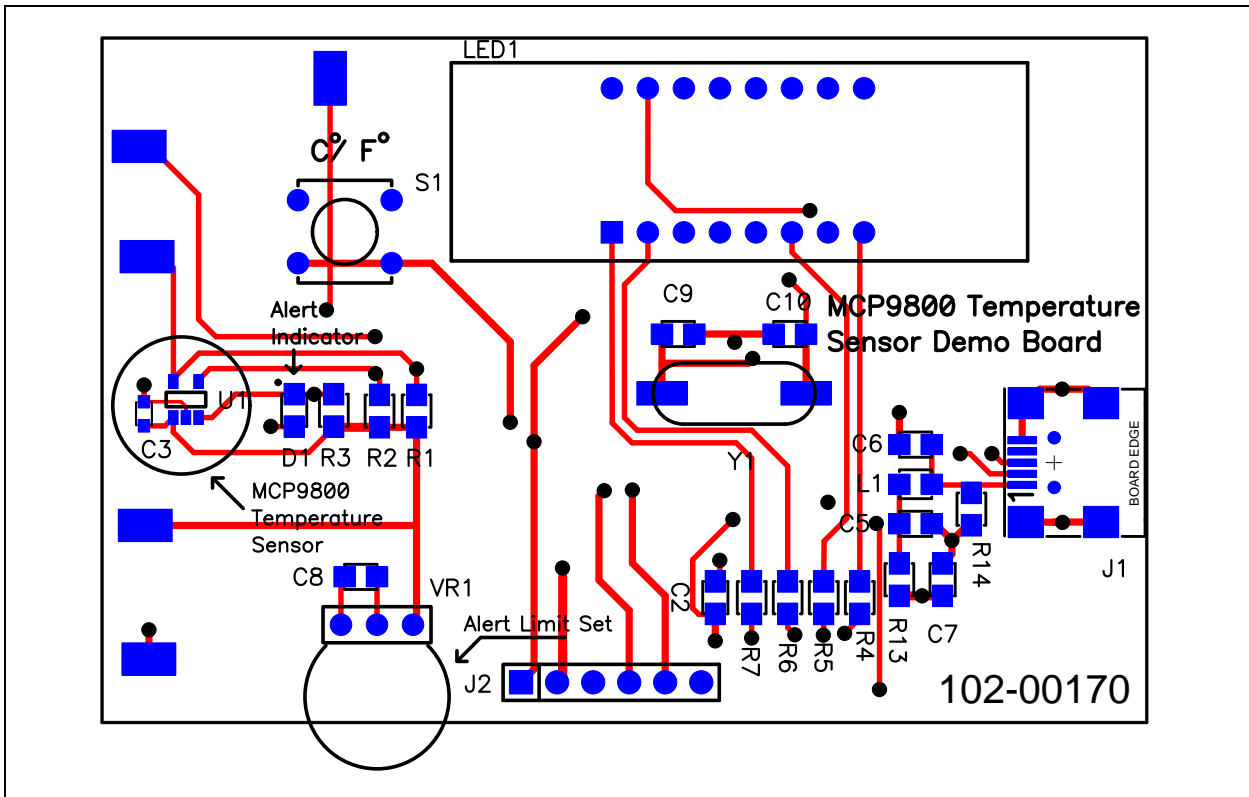

MCP9800 Temperature Sensor Demo Board User's Guide

A.5 BOARD - BOTTOM LAYER

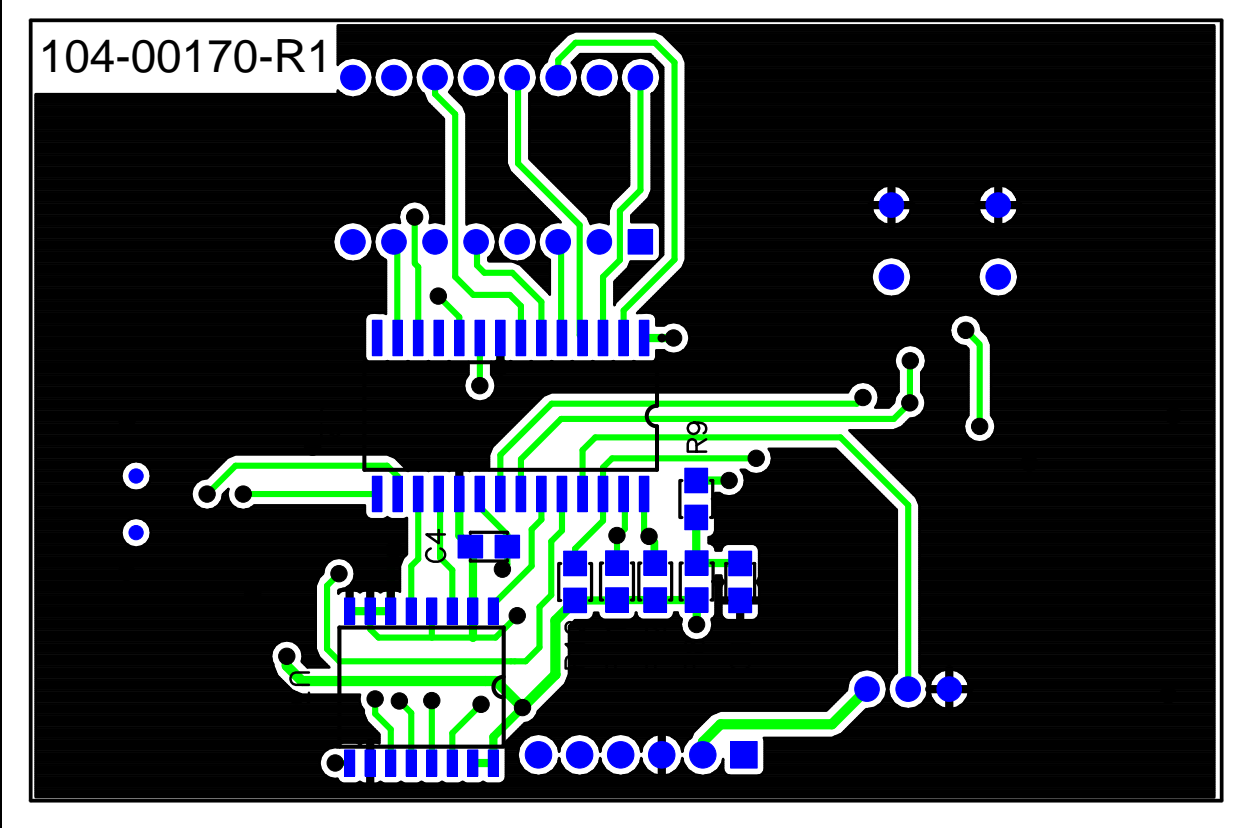



MCP9800 TEMPERATURE SENSOR DEMO BOARD USER'S GUIDE

Appendix B. Bill Of Materials (BOM)

TABLE B-1: BILL OF MATERIALS

Qty	Reference	Description	Manufacturer	Part Number
1	C1	CAP .1UF 25V CERAMIC X7R 0805	Panasonic® - ECG	ECJ-2VB1E104K
1	C2	CAP 4.7UF 6.3V CERAMIC 0805 X5R	Panasonic - ECG	ECJ-2FB0J475M
1	C3	CAP CER 1UF 10V X7R 0603	Murata Electronics® North America	GRM188R71A105KA61D
2	C4, C7	CAP 1.0UF 10V CERAMIC X7R 0805	Kemet	C0805C105K8RACTU
2	C5, C6	CAP CER 10UF 16V Y5V 0805	Murata Electronics North America	GRM21BF51C106ZE15L
1	C8	CAP 1000PF 50V CERAMIC X7R 0805	Kemet® Electronics Corp	C0805C102K5RACTU
2	C9, C10	CAP 22PF 50V CERM CHIP 0805 SMD	Panasonic - ECG	ECJ-2VC1H220J
1	D1	LED RED CLEAR 0805 SMD	Lite-On Trading USA Inc	LTST-C170CKT
4	EA Corner of Bd.	BUMPON TALL TAPER SQ .50X.23 BK (Note: When placing Order, Comes in 64pcs quantities enough for 16 boards.)	3M	SJ-5518 (BLACK)
1	J1	CONN RECEPT MINI USB2.0 5POS	Hirose Electronic Co Ltd	UX60-MB-5ST
1	J2	NOT POPULATED CONN MOD JACK 6-6 R/A PCB 50AU	Tyco®/AMP Electronics	5520470-3
1	L1	INDUCTOR 10UH 100MA 0805	Murata Electronics North America	LQM21FN100M70L
1	LED1	LED 7 Segment .4" 4DGT SUPER RED CA	Panasonic - ECG	LTC-4627JR
1	PCB	RoHS Compliant Bare PCB MCP9800 Temperature Sensor Demo Board	Microchip Technology Inc.	104-00170
5	R1, R2, R10, R11, R12	Chip Resistor, 10.0 kW, 1/10W, 1%, 0805 SMD	Panasonic - ECG	ERJ-6ENF1002V
1	R13	RES 10.0 OHM 1/8W 1% 0805 SMD	Panasonic - ECG	ERJ-6ENF10R0V
1	R14	RES 100K OHM 1/8W 1% 0805 SMD	Panasonic - ECG	ERJ-6ENF1003V
1	R3	RES 1.00K OHM 1/8W 1% 0805 SMD	Panasonic - ECG	ERJ-6ENF1001V

Note: The components listed in this Bill of Materials are representative of the PCB assembly. The released BOM used in manufacturing uses all RoHS-compliant components.

MCP9800 Temperature Sensor Demo Board User's Guide

TABLE B-1: BILL OF MATERIALS (CONTINUED)

Qty	Reference	Description	Manufacturer	Part Number
4	R4, R5, R6, R7	RES 100 OHM 1/8W 1% 0805 SMD	Panasonic - ECG	ERJ-6ENF1000V
1	R8	RES 20.0K OHM 1/8W 1% 0805 SMD	Panasonic - ECG	ERJ-6ENF2002V
1	R9	RES 475 OHM 1/8W 1% 0805 SMD	Panasonic - ECG	ERJ-6ENF4750V
1	S1	SWITCH TACT 6MM SMD MOM 160GF	Omron Electronics, Inc-ECB Div	B3S-1000
1	U1	2-Wire High-Accuracy Temperature Sensor	Microchip Technology Inc.	MCP9800A0T-M/OTRC2
1	U2	28/40/44-Pin, High-Performance, Enhanced Flash, USB Microcontrollers with nanoWatt Technology	Microchip Technology Inc.	PIC18F2550-I/SO
1	U3	Logic-Input CMOS Quad Drivers	Microchip Technology Inc.	TC4469COE
1	VR1	Pot 10k Ohm Thumbwheel Cerm St	Bourns Inc.	3352T-1-103LF
1	Y1	CRYSTAL 20.0000 MHZ SERIES SMT	CTS-Frequency Controls	ATS200SM

Note: The components listed in this Bill of Materials are representative of the PCB assembly. The released BOM used in manufacturing uses all RoHS-compliant components.

Bill Of Materials (BOM)

NOTES:



WORLDWIDE SALES AND SERVICE

AMERICAS

Corporate Office
2355 West Chandler Blvd.
Chandler, AZ 85224-6199
Tel: 480-792-7200
Fax: 480-792-7277
Technical Support:
<http://support.microchip.com>
Web Address:
www.microchip.com

Atlanta
Duluth, GA
Tel: 678-957-9614
Fax: 678-957-1455

Boston
Westborough, MA
Tel: 774-760-0087
Fax: 774-760-0088

Chicago
Itasca, IL
Tel: 630-285-0071
Fax: 630-285-0075

Dallas
Addison, TX
Tel: 972-818-7423
Fax: 972-818-2924

Detroit
Farmington Hills, MI
Tel: 248-538-2250
Fax: 248-538-2260

Kokomo
Kokomo, IN
Tel: 765-864-8360
Fax: 765-864-8387

Los Angeles
Mission Viejo, CA
Tel: 949-462-9523
Fax: 949-462-9608

Santa Clara
Santa Clara, CA
Tel: 408-961-6444
Fax: 408-961-6445

Toronto
Mississauga, Ontario,
Canada
Tel: 905-673-0699
Fax: 905-673-6509

ASIA/PACIFIC

Asia Pacific Office
Suites 3707-14, 37th Floor
Tower 6, The Gateway
Harbour City, Kowloon
Hong Kong
Tel: 852-2401-1200
Fax: 852-2401-3431

Australia - Sydney
Tel: 61-2-9868-6733
Fax: 61-2-9868-6755

China - Beijing
Tel: 86-10-8528-2100
Fax: 86-10-8528-2104

China - Chengdu
Tel: 86-28-8665-5511
Fax: 86-28-8665-7889

China - Hong Kong SAR
Tel: 852-2401-1200
Fax: 852-2401-3431

China - Nanjing
Tel: 86-25-8473-2460
Fax: 86-25-8473-2470

China - Qingdao
Tel: 86-532-8502-7355
Fax: 86-532-8502-7205

China - Shanghai
Tel: 86-21-5407-5533
Fax: 86-21-5407-5066

China - Shenyang
Tel: 86-24-2334-2829
Fax: 86-24-2334-2393

China - Shenzhen
Tel: 86-755-8203-2660
Fax: 86-755-8203-1760

China - Wuhan
Tel: 86-27-5980-5300
Fax: 86-27-5980-5118

China - Xiamen
Tel: 86-592-2388138
Fax: 86-592-2388130

China - Xian
Tel: 86-29-8833-7252
Fax: 86-29-8833-7256

China - Zhuhai
Tel: 86-756-3210040
Fax: 86-756-3210049

ASIA/PACIFIC

India - Bangalore
Tel: 91-80-4182-8400
Fax: 91-80-4182-8422

India - New Delhi
Tel: 91-11-4160-8631
Fax: 91-11-4160-8632

India - Pune
Tel: 91-20-2566-1512
Fax: 91-20-2566-1513

Japan - Yokohama
Tel: 81-45-471- 6166
Fax: 81-45-471-6122

Korea - Daegu
Tel: 82-53-744-4301
Fax: 82-53-744-4302

Korea - Seoul
Tel: 82-2-554-7200
Fax: 82-2-558-5932 or
82-2-558-5934

Malaysia - Kuala Lumpur
Tel: 60-3-6201-9857
Fax: 60-3-6201-9859

Malaysia - Penang
Tel: 60-4-227-8870
Fax: 60-4-227-4068

Philippines - Manila
Tel: 63-2-634-9065
Fax: 63-2-634-9069

Singapore
Tel: 65-6334-8870
Fax: 65-6334-8850

Taiwan - Hsin Chu
Tel: 886-3-572-9526
Fax: 886-3-572-6459

Taiwan - Kaohsiung
Tel: 886-7-536-4818
Fax: 886-7-536-4803

Taiwan - Taipei
Tel: 886-2-2500-6610
Fax: 886-2-2508-0102

Thailand - Bangkok
Tel: 66-2-694-1351
Fax: 66-2-694-1350

EUROPE

Austria - Wels
Tel: 43-7242-2244-39
Fax: 43-7242-2244-393

Denmark - Copenhagen
Tel: 45-4450-2828
Fax: 45-4485-2829

France - Paris
Tel: 33-1-69-53-63-20
Fax: 33-1-69-30-90-79

Germany - Munich
Tel: 49-89-627-144-0
Fax: 49-89-627-144-44

Italy - Milan
Tel: 39-0331-742611
Fax: 39-0331-466781

Netherlands - Drunen
Tel: 31-416-690399
Fax: 31-416-690340

Spain - Madrid
Tel: 34-91-708-08-90
Fax: 34-91-708-08-91

UK - Wokingham
Tel: 44-118-921-5869
Fax: 44-118-921-5820



**Стандарт
Электрон
Связь**

Мы молодая и активно развивающаяся компания в области поставок электронных компонентов. Мы поставляем электронные компоненты отечественного и импортного производства напрямую от производителей и с крупнейших складов мира.

Благодаря сотрудничеству с мировыми поставщиками мы осуществляем комплексные и плановые поставки широчайшего спектра электронных компонентов.

Собственная эффективная логистика и склад в обеспечивает надежную поставку продукции в точно указанные сроки по всей России.

Мы осуществляем техническую поддержку нашим клиентам и предпродажную проверку качества продукции. На все поставляемые продукты мы предоставляем гарантию .

Осуществляем поставки продукции под контролем ВП МО РФ на предприятия военно-промышленного комплекса России , а также работаем в рамках 275 ФЗ с открытием отдельных счетов в уполномоченном банке. Система менеджмента качества компании соответствует требованиям ГОСТ ISO 9001.

Минимальные сроки поставки, гибкие цены, неограниченный ассортимент и индивидуальный подход к клиентам являются основой для выстраивания долгосрочного и эффективного сотрудничества с предприятиями радиоэлектронной промышленности, предприятиями ВПК и научно-исследовательскими институтами России.

С нами вы становитесь еще успешнее!

Наши контакты:

Телефон: +7 812 627 14 35

Электронная почта: sales@st-electron.ru

Адрес: 198099, Санкт-Петербург,
Промышленная ул, дом № 19, литера Н,
помещение 100-Н Офис 331