

Conforms to International Standards ISO/IEC 18000-3 (ISO/IEC 15693)

OMRON

V680 RFID

DeviceNet ID Slave

V680-HAM42-DRT

ID Flag Sensors

V680-HAM91/HAM81



DeviceNet™

RFID with Open Network Compatibility!

V680-HAM42-DRT

Read and write up to 58 bytes.

Use the DeviceNet open network for easier, more-flexible information management on factory sites.

The RFID System Can Be Used Just Like a Sensor.

V680-HAM91/HAM81

Read or write 16 bits at a time with one unit.

Useful in applications from simple line sorting or product identification to managing work progress or inspection data.



realizing

V680 DeviceNet ID Slave V680-HAM42-DRT

V680-series DeviceNet-compatible Slaves for RFID Systems.

Read and Write Up To 58 Bytes.

- V680-series DeviceNet-compatible Slaves for RFID systems.
- Includes a built-in Amplifier, yet has a compact size of 65 × 65 × 65 mm. Compatible with V680-series ID Tags and Antennas.
- Read and write 4, 26, or 58 bytes of data.
- Includes an Access Mode compatible with the V600-HAM42-DRT to enable the use of existing programs.
- Complies with international standards, including CE, UL/CSA, and radio wave regulations. Radio wave regulation compliance is applicable to Japan, Europe, the U.S.A., and Canada. Radio wave regulation compliance for China and South Korea is pending. Approval for UL/CSA is pending.



System Configuration

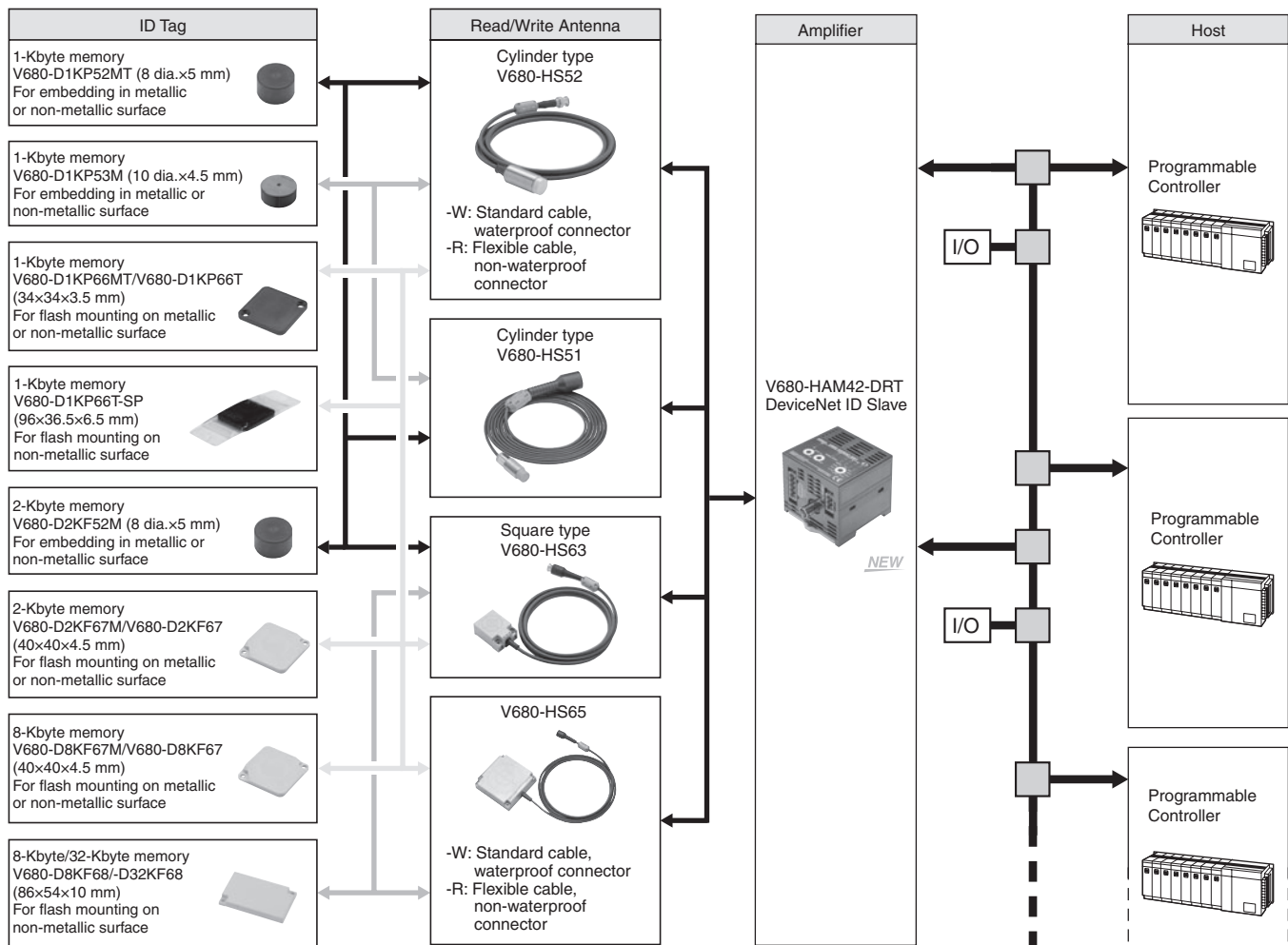

- Note 1.** Attach an Antenna to the V680-HAM42-DRT DeviceNet ID Slave to read and write V680 ID Tag data.
- 2.** The DeviceNet ID Slave can communicate with ID Tags that comply with ISO/IEC 18000-3 (ISO/IEC 15693) in addition to V680-series ID Tags. Communications with ID Tags other than V680-series ID Tags, however, may not be stable. Always check compatibility completely before using other ID Tags.
- 3.** Use a V680-HS51/-HS52 Antenna if the V680-D1KP52MT or V680-D2KF52M is to be embedded in metal. Communications cannot be performed if a V680-HS63 Antenna is used in combination with the V680-D1KP52MT or V680-D2KF52M. The V680-HS65 Antenna cannot communicate with V680-D1KP52MT or V680-D2KF52M ID Tags if they are embedded in metal.

V680 ID Flag Sensors

V680-HAM91/-HAM81

Easy Setup! The RFID System Can Be Used Just Like a Sensor.

Read and Write 16 Bits of Data with 1 Unit.

Useful in Applications from Simple Product Identification to Managing Work Progress

- Read or write 16 bits of data (for up to 64,000 IDs) with one Unit despite its compact size.
- Read or write up to 128 bits by using the address shift function.
- With NPN and PNP outputs
- Equipped with a V600-HAM/HAR-compatible Access Mode, allowing use of existing programs.
- Complies with international standards, including CE, UL/CSA, and radio wave regulations.

Radio wave regulation compliance is applicable to Japan, Europe, the U.S.A., and Canada. Radio wave regulation compliance for China and South Korea is pending.





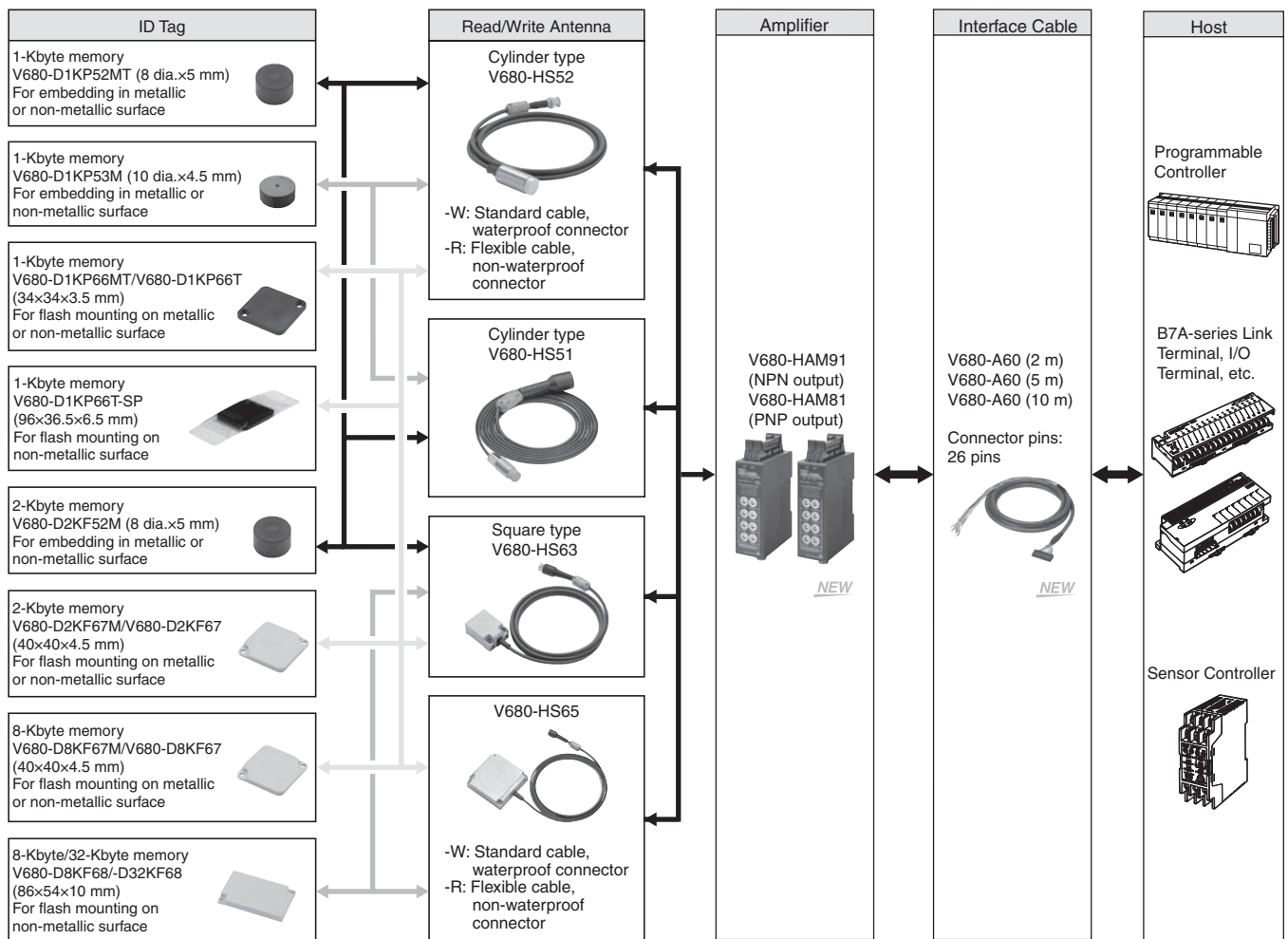



System Configuration







- Note 1.** Attach an Antenna to the V680-HAM91/-HAM81 ID Flag Sensor to read and write V680 ID Tag data.
- Note 2.** The DeviceNet ID Slave can communicate with ID Tags that comply with ISO/IEC 18000-3 (ISO/IEC 15693) in addition to V680-series ID Tags. Communications with ID Tags other than V680-series ID Tags, however, may not be stable. Always check compatibility completely before using other ID Tags.
- Note 3.** Use a V680-HS51/-HS52 Antenna if the V680-D1KP52MT or V680-D2KF52M is to be embedded in metal. Communications cannot be performed if a V680-HS63 Antenna is used in combination with the V680-D1KP52MT or V680-D2KF52M. The V680-HS65 Antenna cannot communicate with V680-D1KP52MT or V680-D2KF52M ID Tags if they are embedded in metal.

Ordering Information

ID Tag

Type	Memory capacity	Appearance	Size	Metallic compatibility	Model
Battery-less	1 Kbyte		Cylindrical, ultra-compact 8 dia. × 5 mm	For embedding in metallic or non-metallic surface	V680-D1KP52MT
			Square 34 × 34 × 3.5 mm	For flush mounting on metallic surface	V680-D1KP66MT
				For flush mounting on non-metallic surface	V680-D1KP66T
		Square PFA package 95 × 36.5 × 6.5 mm	For flush mounting on non-metallic surface	V680-D1KP66T-SP	
	2 Kbytes		Cylindrical, ultra-compact 8 dia. × 5 mm	For embedding in metallic or non-metallic surface	V680-D2KF52M
					Square 40 × 40 × 4.5 mm
For flush mounting on non-metallic surface		V680-D2KF67			
8 Kbytes		86 × 54 × 10 mm	For flush mounting on non-metallic surface	V680-D8KF68	
32 Kbytes				V680-D32KF68	



Read/Write Antenna (Detachable Amplifier Unit Type)

Type	Appearance	Size	Cable length	Model	
Cylindrical		M22 × 65 mm	2 m	V680-HS52-W 2M	
			12.5 m	V680-HS52-W 12.5M	
	Flexible cable, non-waterproof connector	M22 × 65 mm	2 m	V680-HS52-R 2M	
			12.5 m	V680-HS52-R 12.5M	
Standard cable, non-waterproof connector		M12 × 35 mm	2 m	V680-HS51 2M	
Square		40 × 53 × 23 mm	2 m	V680-HS63-W 2M	
			12.5 m	V680-HS63-W 12.5M	
	Flexible cable, non-waterproof connector	40 × 53 × 23 mm	2 m	V680-HS63-R 2M	
			12.5 m	V680-HS63-R 12.5M	
	Standard cable, waterproof connector		100 × 100 × 30 mm	2 m	V680-HS65-W 2M
				12.5 m	V680-HS65-W 12.5M
				2 m	V680-HS65-R 2M
				12.5 m	V680-HS65-R 12.5M

Amplifier: ID Slave for DeviceNet

Appearance	Size	Model
	65 × 65 × 65 mm	V680-HAM42-DRT NEW

Amplifier: ID Flag Sensor



Type	Appearance	Size	Model
NPN output		90 × 30 × 65 mm	V680-HAM91 NEW
PNP output			V680-HAM81 NEW

Interface Cable (for V680-HAM91/81)

Cable length	Model	Appearance
2 m	V680-A60 2M NEW	
5 m	V680-A60 5M NEW	
10 m	V680-A60 10M NEW	

- Note**
1. The connectors are not water resistant.
 2. The cables can be extended to a maximum length of 10 m.
 3. Normally two Interface Cables are required for 1 Unit. If you do not need to write to ID Tags, or use the address shift or noise check functions, then one Interface Cable is sufficient.

Accessories (Order Separately) ID Tag Attachment

Type	Appearance	Model
For the V680-D1KP66T		V600-A86
For the V680-D□KF68		V680-A81

Ratings and Performance

ID Tag (1-Kbyte Memory)

Item	Model	V680-D1KP52MT	V680-D1KP66T	V680-D1KP66MT	V680-D1KP66T-SP
Memory capacity		1,000 byte (user area)			
Memory type		EEPROM			
Data backup time (See note 1.)		10 years after writing (85°C max.)			
Memory longevity		100,000 times per block (at 25°C)			
Ambient operating temperature (during transmission)		-25 to 85°C (with no icing)			-25 to 70°C (with no icing)
Ambient operating temperature (not during transmission)		-40 to 125°C (with no icing) Heat resistance: 1,000 thermal cycles each of 30 minutes at -10°C/150°C, High-temperature storage: 1,000 hours at 150°C (See note 2.) 200 thermal cycles each of 30 minutes at -10°C/180°C, High-temperature storage: 200 hours at 180°C (See note 3.)			-40 to 110°C (with no icing)
Ambient storage temperature		-40 to 125°C (with no icing)			-40 to 110°C (with no icing)
Ambient operating humidity		35 to 95%			
Degree of protection		IEC 60529, IP68 In-house standard for antenna oil resistance (former JEM standard equivalent to IP67g) (See note 4.)			IP67
Vibration resistance		10 to 2,000 Hz, 1.5-mm double amplitude at 150 m/s ² acceleration with 10 sweeps in X, Y, and Z directions for 15 minutes each			
Shock resistance		500 m/s ² in X, Y, and Z directions 3 times each (18 times in total)			
Appearance		8 dia. × 5 mm	34 × 34 × 3.5 mm		95 × 36.5 × 6.5 mm (excluding protrusions)
Materials		Case: PPS resin Filling: Epoxy resin	Molding: PPS resin		External resin: PFA Tag body: PPS resin
Weight		Approx. 0.5 g	Approx. 6 g	Approx. 7.5 g	Approx. 20 g
Metallic compatibility		Yes	No	Yes	No

Note 1. Refer to the *User's Manual* (Cat. No. Z278 or Z279) for data backup time for temperatures of 85°C or higher. If the V680 has been stored at 125°C or higher, write the data again even if the data does not need to be changed.

- 150°C heat resistance: The heat resistance has been checked at 150°C for up to 1,000 hours, and thermal shock has been checked through testing 1,000 thermal cycles each of 30 minutes at -10/150°C. (Test samples: 22, defects: 0)
- 180°C heat resistance: The heat resistance has been checked at 180°C for up to 200 hours, and thermal shock has been checked through testing 200 thermal cycles each of 30 minutes at -10°C/180°C. (Test samples: 22, defects: 0)
- This OMRON in-house standard confirms resistance to cutting and other oils. It is equivalent to the former JEM standard.
- For details, refer to the *User's Manual* (Cat. No. Z278 or Z279).

ID Tag (2-Kbyte Memory)

Item	Model	V680-D2KF52M	V680-D2KF67	V680-D1KF67M
Memory capacity		2,000 bytes (user area)		
Memory type		FRAM		
Data backup time (See note 1.)		10 years after writing (55°C or less)		
Memory longevity		10 billion times per block. Access frequency (See note 2.): 10 billion times		
Ambient operating temperature		-25 to 85°C (with no icing)		
Ambient storage temperature		-40 to 85°C (with no icing)		
Ambient operating humidity		35 to 95%	35 to 85%	
Degree of protection		IEC 60529, IP67 In-house standard for antenna oil resistance (former JEM standard equivalent to IP67g) (See note 3.)		
Vibration resistance		10 to 2,000 Hz, 1.5-mm double amplitude at 150 m/s ² acceleration with 10 sweeps in X, Y, and Z directions for 15 minutes each		
Shock resistance		500 m/s ² in X, Y, and Z directions 3 times each (18 times in total)		
Appearance		8 dia. × 5 mm	40 × 40 × 4.5 mm	
Materials		Case: PPS resin Filling: Epoxy resin	Molding: ABS resin Filling: Epoxy resin	
Weight		Approx. 0.5 g	Approx. 6.5 g	Approx. 7 g
Metallic compatibility		Yes	No	Yes

Note 1. Refer to the *User's Manual* (Cat. No. Z278 or Z279) for data backup time for temperatures of 55°C or higher.

- The total Read or Write communication frequency is called the access frequency.
- This OMRON in-house standard confirms resistance to cutting and other oils. It is equivalent to the former JEM standard.
- For details, refer to the *User's Manual* (Cat. No. Z278 or Z279).

ID Tag with 8-/32-Kbyte Memory

Item	Model	V680-D8KF68	V680-D32KF68
Memory capacity		8,192 bytes (user area)	32,744 bytes (user area)
Memory type		FRAM	
Data backup time (See note 1.)		10 years (at 70°C max.) after data is written	
Memory longevity		10 billion times per block at 85°C max. Access frequency (See note): 10 billion times	
Ambient operating temperature		-20 to 85°C (with no icing)	
Ambient storage temperature		-40 to 85°C (with no icing)	
Ambient operating humidity		35 to 85%	
Degree of protection		IEC 60529, IP67 In-house standard for antenna oil resistance (former JEM standard equivalent to IP67g) (See note 2.)	
Vibration resistance		10 to 500 Hz, 1.5-mm double amplitude at 100 m/s ² acceleration with 10 sweeps in X, Y, and Z directions for 11 minutes each	
Shock resistance		500 m/s ² in X, Y, and Z directions 3 times each (18 times in total)	
Dimensions		86 × 54 × 10 mm	
Materials		Case: PBT resin Filling: Epoxy resin	
Weight		Approx. 50 g	
Metallic compatibility		No	

Note 1. Refer to the *User's Manual* (Cat. No. Z278 or Z279) for data backup time for temperatures of 70°C or higher.

2. The total Read or Write communication frequency is called the access frequency.
3. This OMRON in-house standard confirms resistance to cutting and other oils. It is equivalent to the former JEM standard.
4. For details, refer to the *User's Manual* (Cat. No. Z278 or Z279).

Cylindrical Read/Write Antenna (Detachable Amplifier Unit Type)

Item	Model	V680-HS52-W (Standard Cable, Waterproof Connector)	V680-HS52-R (Flexible Cable, Non-waterproof Connector)	V680-HS51 (Standard Cable, Non-waterproof Connector)
Ambient operating temperature		-10 to 60°C (with no icing)		
Ambient storage temperature		-25 to 75°C (with no icing)		
Ambient operating humidity		35% to 95% (with no condensation)		
Insulation resistance		20 MΩ min. (at 500 VDC) between the cable terminals and the case		
Dielectric strength		1,000 VAC (50/60 Hz) for 1 minute between the cable terminals and the case with a current leakage of 5 mA max.		
Degree of protection		IP67 (IEC60529) In-house standard for antenna oil resistance (former JEM standard equivalent to IP67g) (Read/Write Antenna portion) (See note 1.)	IP67 (IEC60529) In-house standard for antenna oil resistance (former JEM standard equivalent to IP67g) (Read/Write Antenna portion) (See note 2.)	
Vibration resistance		10 to 500 Hz variable vibration, 1.5-mm double amplitude at 100 m/s ² acceleration, with 10 sweeps in X, Y, and Z directions for 8 minutes each		10 to 2,000 Hz variable vibration, 1.5-mm double amplitude at 150 m/s ² acceleration, with 10 sweeps in X, Y, and Z directions for 15 minutes each
Shock resistance		500 m/s ² in X, Y, and Z directions 3 times each (18 times in total)		1,000 m/s ² in X, Y, and Z directions 3 times each (18 times in total)
Appearance		M22 × 65 mm		M12 × 35 mm
Materials		ABS, brass, epoxy resin filling		
Weight		Approx. 850 g (with 12.5-m cable)		Approx. 55 g (with 2-m cable)

Note 1. The degree of protection for the Connector is IP67/IP65. This OMRON in-house standard confirms resistance to cutting and other oils. It is equivalent to the former JEM standard.

2. The Connector is not waterproof. This OMRON in-house standard confirms resistance to cutting and other oils. It is equivalent to the former JEM standard.
3. For details, refer to the *User's Manual* (Cat. No. Z278 or Z279).

Square Read/Write Antenna (Detachable Amplifier Unit Type)

Item	Model	V680-HS63-W (Standard Cable, Waterproof Connector)	V680-HS63-R (Flexible Cable, Non-waterproof Connector)
Ambient operating temperature		-10 to 60°C (with no icing)	
Ambient storage temperature		-25 to 75°C (with no icing)	
Ambient operating humidity		35% to 95% (with no condensation)	
Insulation resistance		20 MΩ min. (at 500 VDC) between the cable terminals and the case	
Dielectric strength		1,000 VAC (50/60 Hz) for 1 minute between the cable terminals and the case with a current leakage of 5 mA max.	
Degree of protection		IP67 (IEC60529) In-house standard for antenna oil resistance (former JEM standard equivalent to IP67g) (Read/Write Antenna portion) (See note 1.)	IP67 (IEC60529) In-house standard for antenna oil resistance (former JEM standard equivalent to IP67g) (Read/Write Antenna portion) (See note 2.)
Vibration resistance		10 to 500 Hz variable vibration, 1.5-mm double amplitude at 100 m/s ² acceleration, with 10 sweeps in X, Y, and Z directions for 11 minutes each	
Shock resistance		500 m/s ² in X, Y, and Z directions 3 times each (18 times in total)	
Appearance		40 × 53 × 23 mm	
Materials		ABS, epoxy resin filling	
Weight		Approx. 850 g (with 12.5-m cable)	

Item	Model	V680-HS65-W (Standard Cable, Waterproof Connector)	V680-HS65-R (Flexible Cable, Non-waterproof Connector)
Ambient operating temperature		-25 to 70°C (with no icing)	
Ambient storage temperature		-40 to 85°C (with no icing)	
Ambient operating humidity		35% to 95% (with no condensation)	
Insulation resistance		20 MΩ min. (at 500 VDC) between the cable terminals and the case	
Dielectric strength		1,000 VAC (50/60 Hz) for 1 minute between the cable terminals and the case with a current leakage of 5 mA max.	
Degree of protection		In-house standard for antenna oil resistance (former JEM standard equivalent to IP67g) (Read/Write Antenna portion) (See note 1.)	In-house standard for antenna oil resistance (former JEM standard equivalent to IP67g) (Read/Write Antenna portion) (See note 2.)
Vibration resistance		10 to 500 Hz variable vibration, 1.5-mm double amplitude at 100 m/s ² acceleration, with 10 sweeps in X, Y, and Z directions for 11 minutes each	
Shock resistance		500 m/s ² in X, Y, and Z directions 3 times each (18 times in total)	
Appearance		100 × 100 × 30 mm	
Materials		ABS, epoxy resin filling	
Weight		Approx. 1,100 g (with 12.5-m cable)	

- Note 1.** The degree of protection for the Connector is IP67/IP65. This OMRON in-house standard confirms resistance to cutting and other oils. It is equivalent to the former JEM standard.
- 2.** The Connector is not waterproof. This OMRON in-house standard confirms resistance to cutting and other oils. It is equivalent to the former JEM standard.
- 3.** For details, refer to the *User's Manual* (Cat. No. Z278 or Z279).

Amplifier (DeviceNet ID Slave)

Item	Model	V680-HAM42-DRT
Connectable Antennas		One channel (V680-HS□□)
Rated voltage		24 VDC (-15% to 10%) including 10% ripple (p-p)
Power consumption		4 W max. (Current consumption of 200 mA max. at power supply voltage of 24 VDC)
Ambient operating temperature		-10 to 55°C (with no icing)
Ambient storage temperature		-25 to 65°C (with no icing)
Ambient operating humidity		25% to 85% (with no condensation; ambient operating temperature is 40°C max. at humidity of 85%)
Insulation resistance		20 MΩ min. (at 500 VDC) between all terminals excluding the ground terminal and the case
Dielectric strength		1,000 VAC (50/60 Hz) for 1 minute between all terminals excluding the ground terminal and the case
Vibration resistance		10 to 150 Hz, 0.2-mm double amplitude at 15 m/s ² acceleration with 10 sweeps in X, Y and Z directions for 8 minutes each
Shock resistance		150 m/s ² in X, Y, and Z directions 3 times each (18 times in total)
Appearance		65 × 65 × 65 mm (excluding protrusions)
Degree of protection		IEC 60529, IP20
Materials		Polycarbonate (PC) resin, ABS resin
Weight		Approx. 150 g
Mounting		DIN Track

- Note 1.** For details, refer to the *User's Manual* (Cat. No. Z278).
- 2.** The number of words allocated in the master depends on the Access Mode. Refer to page 9 for information on *Part Names and Operating Modes*.

Amplifier: ID Flag Sensor

Item	Model	V680-HAM91/V680-HAM81
Rated voltage		24 VDC (-15% to +10%) including 10% ripple (p-p)
Power consumption		3.5 W (24 VDC, 150 mA max. except external I/O line current)
Ambient operating temperature		-10 to 55°C (with no icing)
Ambient storage temperature		-25 to 65°C (with no icing)
Ambient operating humidity		25% to 85% (with no condensation; ambient operating temperature is 40°C max. at humidity of 85%)
Insulation resistance		20 MΩ min. (at 500 VDC) between all terminals excluding the FG terminal and the case
Dielectric strength		1,000 VAC (50/60 Hz) applied for 1 minute between all terminals excluding the FG terminal and the case
Vibration resistance		10 to 150 Hz, 0.2-mm double amplitude at 15 m/s ² acceleration with 10 sweeps in X, Y and Z directions for 8 minutes each
Shock resistance		150 m/s ² in X, Y, and Z directions 3 times each (18 times in total)
Appearance		90 × 30 × 65 mm (excluding protrusions)
Degree of protection		IEC 60529, IP40
Materials		Polycarbonate (PC) resin, ABS resin
Weight		Approx. 130 g
Mounting		DIN Track

Note 1. For details, refer to the *User's Manual* (Cat. No. Z278).

2. The connectors are not water resistant. If there is a possibility that water will be splashed onto the ID Sensor Unit, mount it inside of a control box. Also, be sure to use the V680 as a set with the V680-A60 Interface Cable (sold separately).

I/O Specifications

Item	Model	V680-HAM91	V680-HAM81
Input specifications		Transistor output Short-circuit current: 3 mA (TYP) (input terminal and 0-V terminal shorted) OFF voltage: 15 to 30 VDC, ON voltage: 0 to 5 VDC Input impedance: 8.2 kΩ Applied voltage: 30 VDC max.	
Output specifications		NPN open-collector output 30 VDC, 20 mA max Residual voltage: 2 V max.	PNP open-collector output 30 VDC, 20 mA max Residual voltage: 2 V max.

I/O Circuit Diagrams

V680-HAM91

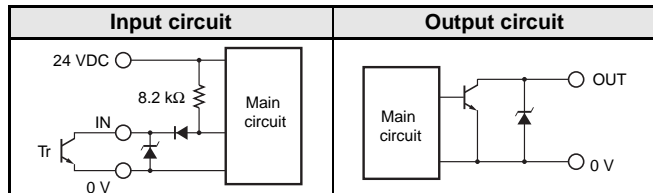

V680-HAM81

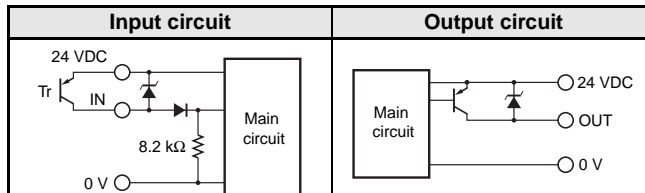

Part Names and Operating Modes

V680-HAM42-DRT

Part Names

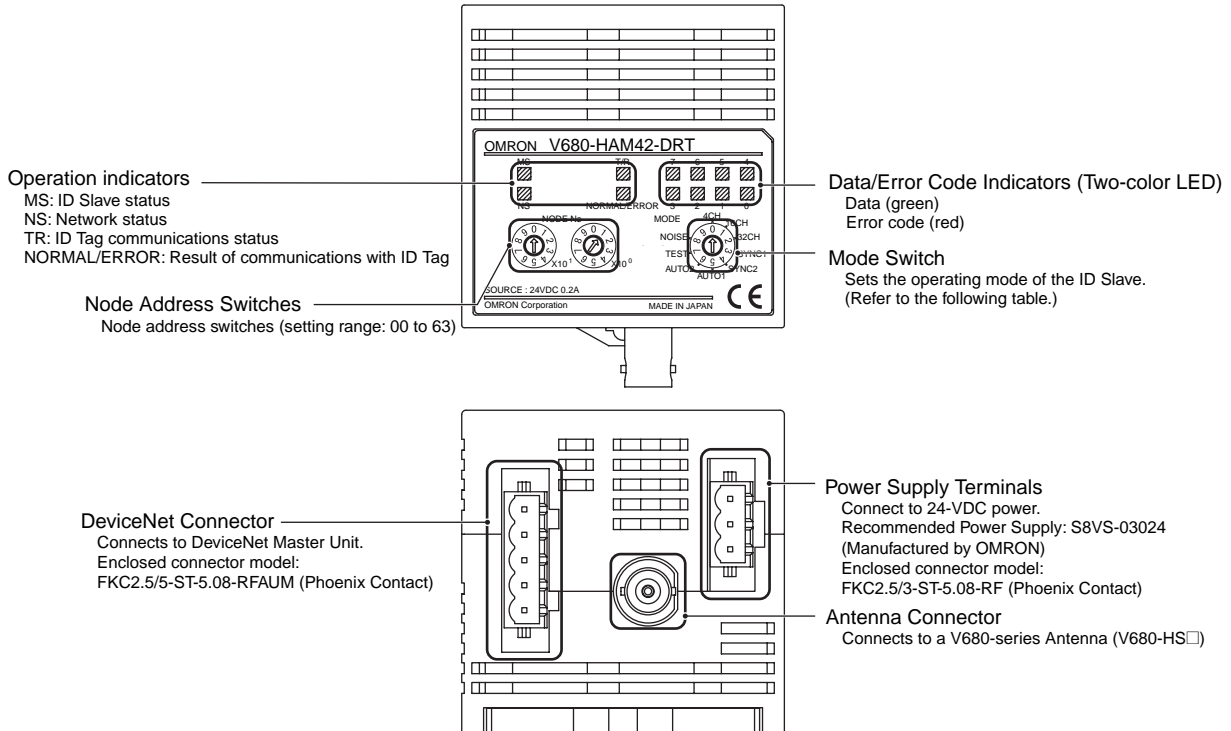

Operating Modes

Mode	Symbol	Description	Maximum number of bytes accessible in ID Tag	Words allocated in Master Unit
0	4CH	4-byte Access Mode	Read: 4 bytes Write: 4 bytes	IN: 4 words OUT: 4 words (PLC inputs: 64 points, PLC outputs: 64 points)
1	16CH	26-byte Access Mode	Read: 26 bytes Write: 26 bytes	IN: 16 words OUT: 16 words (PLC inputs: 256 points, PLC outputs: 256 points)
2	32CH	58-byte Access Mode	Read: 58 bytes Write: 58 bytes	IN: 32 words OUT: 32 words (PLC inputs: 512 points, PLC outputs: 512 points)
3	SYNC1	V600-compatible Trigger Mode, 100-ms output time	Read: 3 bytes Write: 2 bytes	IN: 2 words OUT: 2 words
4	SYNC2	V600-compatible Trigger Mode, 500-ms output time		
5	AUTO1	V600-compatible Auto Mode, 100-ms output time		
6	AUTO2	V600-compatible Auto Mode, 500-ms output time		
7	TEST	ID Tag Communications Test Mode (Checks standalone operation of ID Slave.)	---	---
8	NOISE	Noise Measurement Mode (Measures the noise around the Antenna.)		
9	---	Setting prohibited		

Note 1. The V600-compatible Trigger and Auto Modes can be used with the same I/O settings and control methods that are used with the V600-HAM42-DRT.

2. Communications with the host device will be offline while the Communications Test Mode or Noise Measurement Mode is being used.

Commands (4-byte, 26-byte, 58-byte Access Mode)

Reading	READ	Data in the ID Tag memory is read by specifying the memory address and the number of bytes to process. (The number of bytes can be specified using the Access Mode.)
Writing	WRITE	Data is written to the ID Tag by specifying the memory address, number of bytes to process, and the data. (The number of bytes can be specified using the Access Mode.)
	BIT SET	Previously specified bits (i.e., bits that are turned ON) are turned ON in the ID Tag address specified for BIT SET.
	BIT CLEAR	Previously specified bits (i.e., bits that are turned ON) are turned OFF in the ID Tag address specified for BIT CLEAR.
	DATA FILL	The specified continuous memory addresses in the ID Tag are filled with the same data.

V680-HAM91/-HAM81

Parts Names

I/O connector CN2
Connects to a PLC or other host using an Interface Cable (V680-A60). This connector is not required if data will not be written to ID Tags or the address shift function and noise check function will not be used.

I/O connector CN1
Connects to a PLC or other host using an Interface Cable (V680-A60).

Access Address Mode Setting Switch
Sets the memory address in the ID Tag that will be accessed.

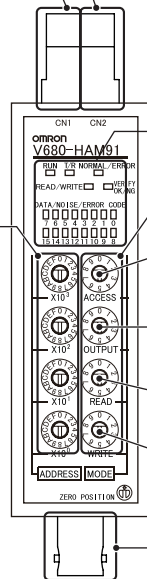

Indicators
Indicates the ID Flag Sensor status and ID Tag communications status.

Mode Setting Switches

Access Mode Setting
Sets the operating mode (SYNC or AUTO) for communications with the ID Tag, and sets the Noise Measurement Mode. (Refer to the following table.)

Output Mode Setting
Sets the Output Mode (10-ms, 50-ms, or 500-ms OFF-delay), and output time setting (10-ms, 50-ms, 500-ms, or Continuous output).

Read Mode Setting
Sets the mode for reading from an ID Tag DATA READ, VERIFY, or Wire-saving Mode.

Write Mode Setting
Sets the mode used when writing (16-bit write/8-bit write, BIT SET/BIT CLEAR).

Antenna Connector
Connects to a V680-series Antenna (V680-HS□).

Main Functions

Reading	Data Read	Reads 16 bits of data from the set address in the ID Tag and outputs the data to the data output lines.
	Verify	Compares the code set in advance with the code read from the ID Tag and outputs the match/mismatch result.
	Wire-saving Mode	The wire-saving mode enables reading and writing 16-bit data using one 16-point Input Unit for a PLC or other host device.
Writing	Data Write	Writes the data specified in the data input lines. (The user can select to batch-write 16 bits or 8 bits.)
	Bit Set	Sets specified bits.
	Bit Clear	Clears specifies bits.

Other Functions

Address Shift	When reading or writing more than 16 bits (2 bytes), an address shift can be specified to enable reading or writing up to 128 bits (16 addresses). The address shift can be set from the host, eliminating the need to change the address set on the front panel.
Noise Check	Measures the noise around the Antenna.
Write Protection	Prevents data stored in the ID Tag from being overwritten.

Operating Modes

Function		Mode	Standard modes	V600-HAR91/81 and HAM91/81-compatible modes	V600-HAR92-compatible modes
			AUTO MODE 1 TRIGGER MODE 1	AUTO MODE 2 TRIGGER MODE 2	AUTO MODE 3 TRIGGER MODE 3
Reading	16 bits	●		(●) (See note 1.)	●
	Verification Check	●		●	
	Wire-saving Mode (See note 2.)	●			●
Writing	8 bits (1 byte)	●		●	
	16 bits (2 bytes)	●		●	
	Individual bits (BIT SET or BIT CLEAR)	●		●	
Parity check output (See note 3.)		●			●
Noise check function		●			
Address shift function		●			

Note 1. If an error occurs, the error code will not be output to the data output lines (OD0 to OD15).









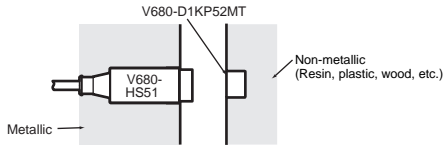

2. If an error occurs, the data output lines will all turn ON.

3. The parity is also output when the error code is output.

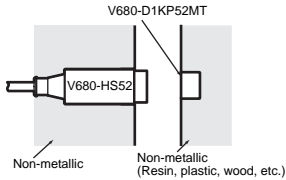
4. The V600-compatible modes are for compatibility with the previous V600 Series. Not all functions are supported in these modes.

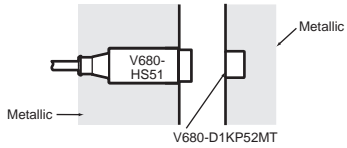
■ Performance Specifications

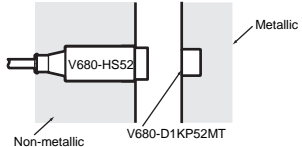

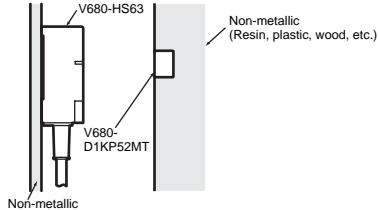









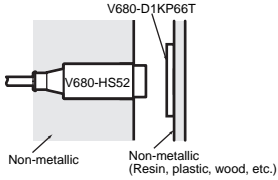

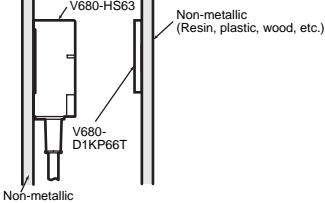
ID Tag (1-kbyte Memory) Transmission



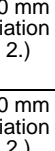
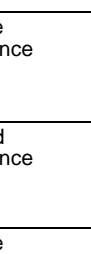

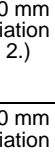
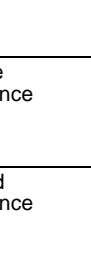

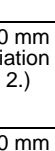
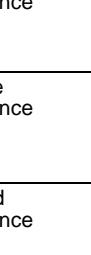
Recommended combination		Function	Transmission distance (unit: mm)	ID Tag and Read/Write Antenna mounting conditions
ID Tag	Read/Write Antenna			
		Read distance	0.5 to 6.5 mm (axial deviation ± 2)	
		Write distance	0.5 to 6.0 mm (axial deviation ± 2)	
		Read distance	0.5 to 9.0 mm (axial deviation ± 2)	
		Write distance	0.5 to 8.5 mm (axial deviation ± 2)	
V680-D1KP52MT (embedded in metallic surface: steel) 		Read distance	0.5 to 3.5 mm (axial deviation ± 2)	
		Write distance	0.5 to 3.0 mm (axial deviation ± 2)	
		Read distance	0.5 to 4.5 mm (axial deviation ± 2)	
		Write distance	0.5 to 4.0 mm (axial deviation ± 2)	
		Read distance	0.5 to 12.0 mm (axial deviation ± 2)	
		Write distance	0.5 to 9.5 mm (axial deviation ± 2)	

Note 1. When mounting the V680-HS65, be sure to attach the Mounting Brackets at the base of the Antenna.

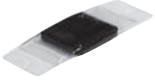
The enclosed Mounting Brackets do not need to be used, however, if the mounting brackets on the Antenna are metal plates and their dimensions are larger than the dimensions of the Antenna (100 x 100 mm).
For details, refer to the *User's Manual* (Cat. No. Z248 or Z262).

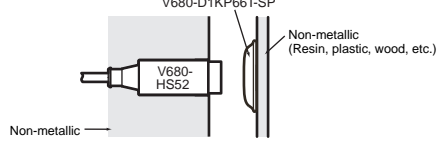

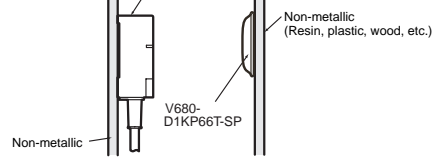

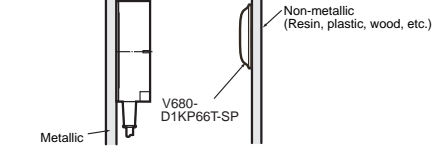







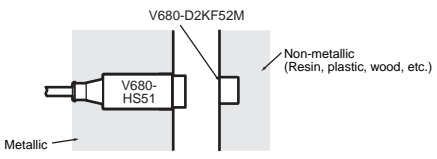

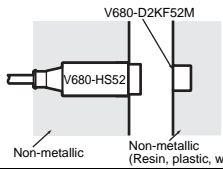

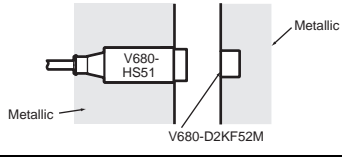
2. The transmission distance may be reduced if the V680-D1KP66T or V680-D1KP58HT is mounted onto a metallic surface. Refer to the *User's Manual* (V680-D1KP□□: Cat. No. Z262, V680-D1KP58HT: Cat. No. Z221) for details.

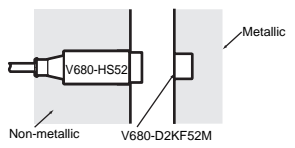

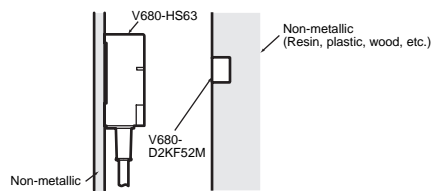

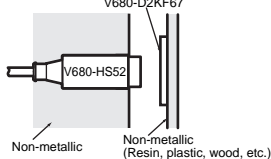
Recommended combination		Function	Transmission distance (unit: mm)	ID Tag and Read/Write Antenna mounting conditions	
ID Tag	Read/Write Antenna				
		Read distance	1.0 to 17.0 mm (axial deviation ± 2) (See note 2.)		
		Write distance	1.0 to 17.0 mm (axial deviation ± 2) (See note 2.)		
			Read distance	5.0 to 30.0 mm (axial deviation ± 10) (See note 2.)	
			Write distance	5.0 to 25.0 mm (axial deviation ± 10) (See note 2.)	
			Read distance	5.0 to 47.0 mm (axial deviation ± 10) (See note 2.)	
			Write distance	5.0 to 42.0 mm (axial deviation ± 10) (See note 2.)	
		Read distance	1.0 to 16.0 mm (axial deviation ± 2)		
		Write distance	1.0 to 14.0 mm (axial deviation ± 2)		
			Read distance	5.0 to 25.0 mm (axial deviation ± 10)	
			Write distance	5.0 to 20.0 mm (axial deviation ± 10)	
			Read distance	5.0 to 25.0 mm (axial deviation ± 10)	
			Write distance	5.0 to 20.0 mm (axial deviation ± 10)	

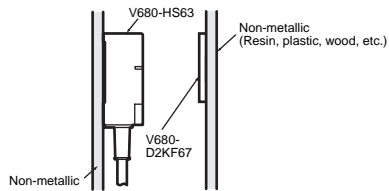
Recommended combination		Function	Transmission distance (unit: mm)	ID Tag and Read/Write Antenna mounting conditions
ID Tag	Read/Write Antenna			
		Read distance	1.0 to 15.0 mm (axial deviation ±2)	
		Write distance	1.0 to 15.0 mm (axial deviation ±2)	
		Read distance	5.0 to 25.0 mm (axial deviation ±10)	
		Write distance	5.0 to 20.0 mm (axial deviation ±10)	
		Read distance	5.0 to 42.0 mm (axial deviation ±10)	
		Write distance	5.0 to 37.0 mm (axial deviation ±10)	

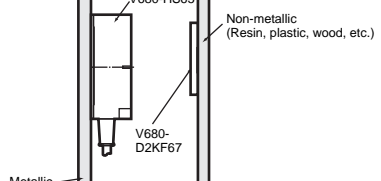

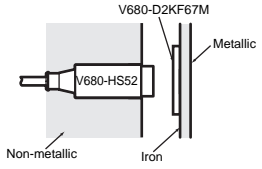

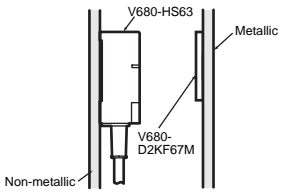

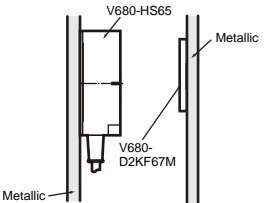
- Note 1.** When mounting the V680-HS65, be sure to attach the Mounting Brackets at the base of the Antenna.
 The enclosed Mounting Brackets do not need to be used, however, if the mounting brackets on the Antenna are metal plates and their dimensions are larger than the dimensions of the Antenna (100 × 100 mm).
 For details, refer to the *User's Manual* (Cat. No. Z248 or Z262).
- 2.** Refer to the *User's Manual* (V680-D1KP□□: Cat. No. Z262, V680-D1KP58HT: Cat. No. Z221) for details.

ID Tag (2-kbyte Memory) Transmission

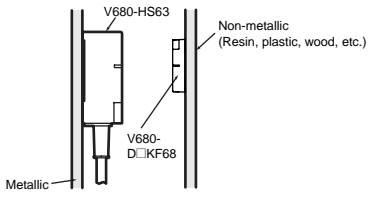
Recommended combination		Function	Transmission distance (unit: mm)	ID Tag and Read/Write Antenna mounting conditions
ID Tag	Read/Write Antenna			
 V680-D2KF52M	 V680-HS51	Read distance	0.5 to 5.5 mm (axial deviation ± 2)	
		Write distance	0.5 to 5.5 mm (axial deviation ± 2)	
	 V680-HS52	Read distance	0.5 to 8.0 mm (axial deviation ± 2)	
		Write distance	0.5 to 8.0 mm (axial deviation ± 2)	
 V680-D2KF52M (embedded in metallic surface: steel)	 V680-HS51	Read distance	0.5 to 3.5 mm (axial deviation ± 2)	
		Write distance	0.5 to 3.5 mm (axial deviation ± 2)	
	 V680-HS52	Read distance	0.5 to 3.0 mm (axial deviation ± 2)	
		Write distance	0.5 to 3.0 mm (axial deviation ± 2)	
 V680-D2KF52M	 V680-HS63	Read distance	0.5 to 9.5 mm (axial deviation ± 2)	
		Write distance	0.5 to 9.5 mm (axial deviation ± 2)	
 V680-D2KF67	 V680-HS52	Read distance	1.0 to 17.0 mm (axial deviation ± 2) (See note.)	
		Write distance	1.0 to 17.0 mm (axial deviation ± 2) (See note.)	
	 V680-HS63	Read distance	7.0 to 30.0 mm (axial deviation ± 10) (See note.)	
		Write distance	7.0 to 30.0 mm (axial deviation ± 10) (See note.)	
	 V680-HS65	Read distance	5.0 to 42.0 mm (axial deviation ± 10) (See note.)	
		Write distance	5.0 to 42.0 mm (axial deviation ± 10) (See note.)	

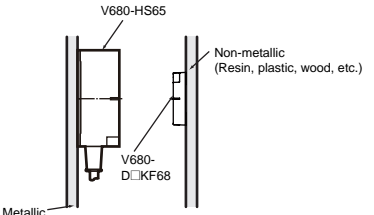
Recommended combination		Function	Transmission distance (unit: mm)	ID Tag and Read/Write Antenna mounting conditions
ID Tag	Read/Write Antenna			
V680-D2KF67M (flush-mounted on metallic surface: steel)		Read distance	1.0 to 16.0 mm (axial deviation ±2)	
		Write distance	1.0 to 16.0 mm (axial deviation ±2)	
		Read distance	6.0 to 25.0 mm (axial deviation ±10)	
		Write distance	6.0 to 25.0 mm (axial deviation ±10)	
		Read distance	5.0 to 25.0 mm (axial deviation ±10)	
		Write distance	5.0 to 25.0 mm (axial deviation ±10)	

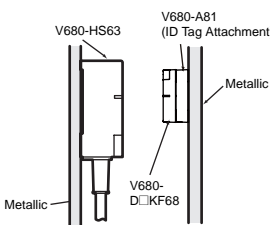
ID Tag (8-/32-Kbyte Memory) Transmission

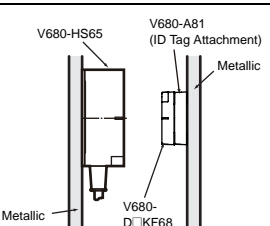
Recommended combination		Function	Transmission distance (unit: mm)	ID Tag and Read/Write Antenna mounting conditions
ID Tag	Read/Write Antenna			
V680-D8KF68/ -D32KF68		Read distance	5.0 to 45.0 mm (axial deviation ±10) (See note.)	
		Write distance	5.0 to 45.0 mm (axial deviation ±10) (See note.)	
		Read distance	5.0 to 75.0 mm (axial deviation ±10) (See note.)	
		Write distance	5.0 to 75.0 mm (axial deviation ±10) (See note.)	
V680-D8KF68/ -D32KF68 (Special attachment provided; flush-mounted on metallic surface: steel)		Read distance	5.0 to 35.0 mm (axial deviation ±10)	
		Write distance	5.0 to 35.0 mm (axial deviation ±10)	
		Read distance	5.0 to 55.0 mm (axial deviation ±10)	
		Write distance	5.0 to 55.0 mm (axial deviation ±10)	

Note: When mounting the V680-HS65, be sure to attach the Mounting Brackets at the base of the Antenna. The enclosed Mounting Brackets do not need to be used, however, if the mounting brackets on the Antenna are metal plates and their dimensions are larger than the dimensions of the Antenna (100 × 100 mm). For details, refer to the *User's Manual* (Cat. No. Z248 or Z262).

Note: The transmission distance may be reduced if the V680-D1KP66T or V680-D1KP58HT is mounted onto a metallic surface. Refer to the *User's Manual* (V680-D1KP□□: Cat. No. Z262, V680-D1KP58HT: Cat. No. Z221) for details.

Characteristic Data (Typical)

Transmission Range

(unit: mm)

1-kbyte Memory ID Tag

The values given for communications ranges are reference values. Refer to pages 11 to 13 for communications distance specifications. The communications distance will depend on the ID Tags, ambient temperature, surrounding metal, noise, and other factors. Test operation completely when installing a system.

V680-HS52 (embedded in non-metallic material) & V680-D1KP52MT

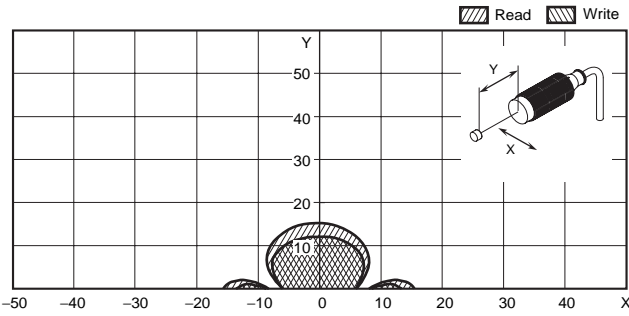

V680-HS52 (embedded in non-metallic material) & V680-D1KP52MT (embedded in metallic surface: steel)

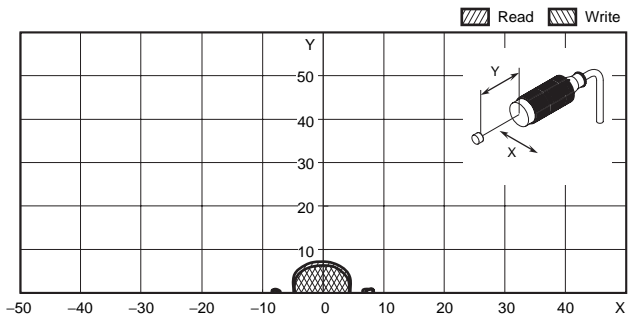

V680-HS51 (embedded in metallic material) & V680-D1KP52MT

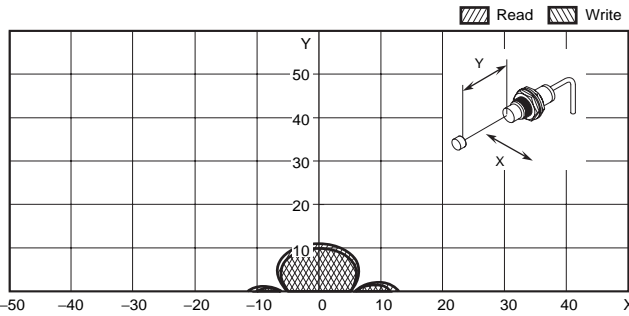

V680-HS51 (embedded in metallic material) & V680-D1KP52MT (embedded in metallic surface: steel)

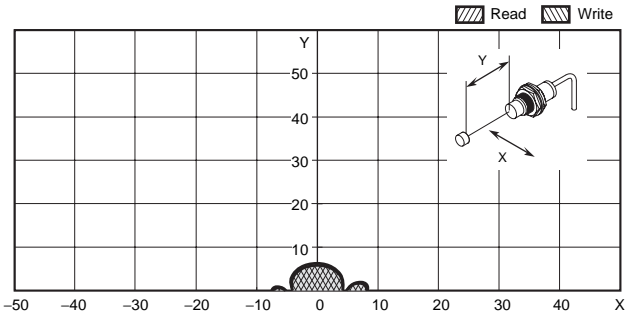

V680-HS63 (mounted on non-metallic material) & V680-D1KP52MT

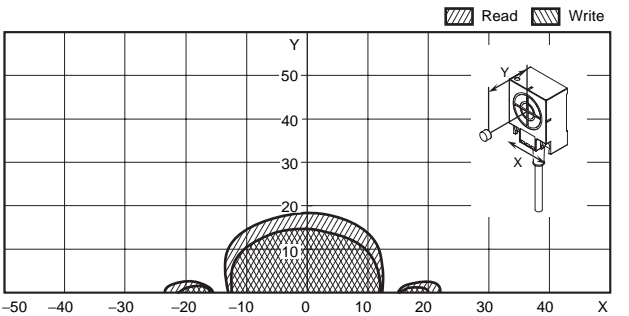

V680-HS52 (embedded in non-metallic material) & V680-D1KP66T

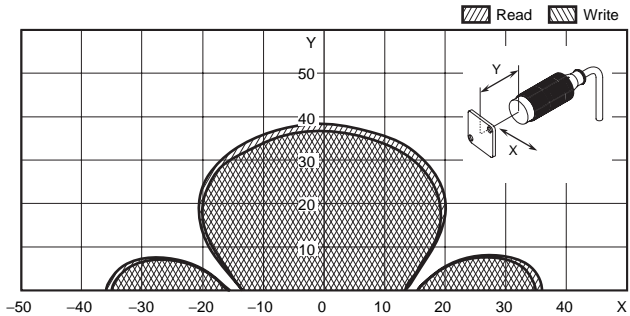

V680-HS63 (mounted on non-metallic material) & V680-D1KP66T

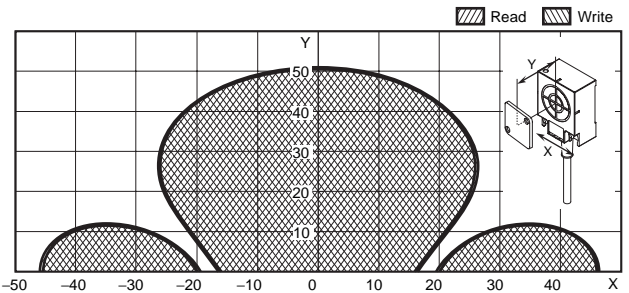

V680-HS65 (mounted on metallic material) & V680-D1KP66T

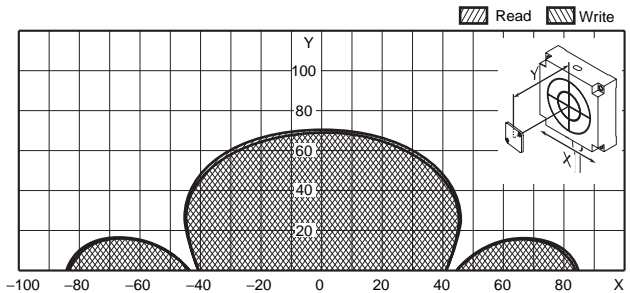

V680-HS52 (embedded in non-metallic material) & V680-D1KP66T-SP

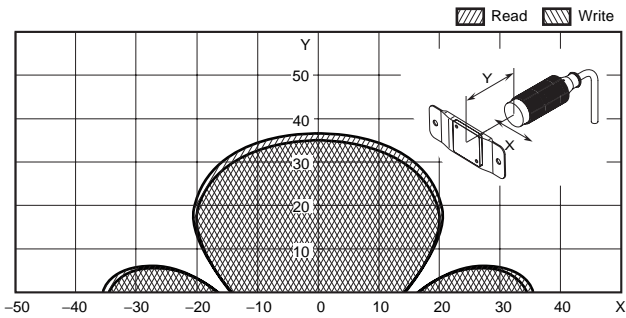

V680-HS63 (mounted on non-metallic material) & V680-D1KP66T-SP

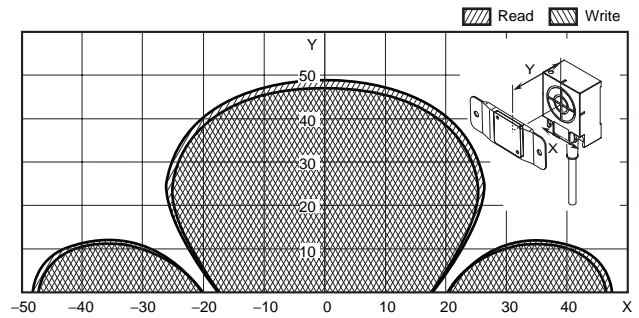

V680-HS65 (mounted on metallic material) & V680-D1KP66T-SP

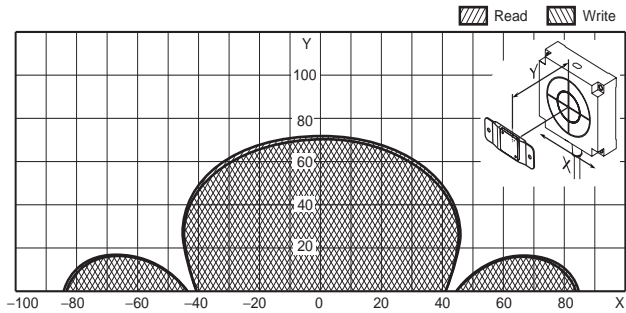

V680-HS52 (embedded in non-metallic material) & V680-D1KP66MT (flush-mounted on metallic surface: steel)

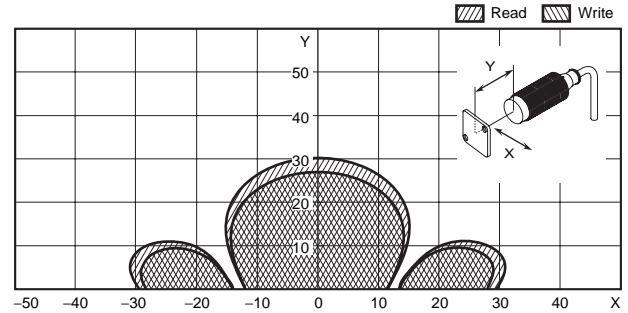

V680-HS63 (mounted on non-metallic material) & V680-D1KP66MT (flush-mounted on metallic surface: steel)

V680-HS65 (mounted on metallic material) & V680-D1K66MT (flush-mounted on metallic surface: steel)

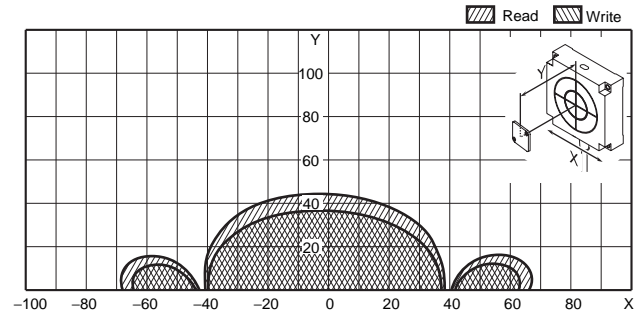
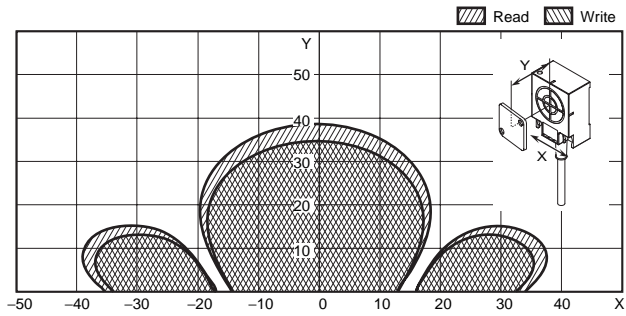

2-kbyte Memory ID Tag

The values given for communications ranges are reference values. Refer to pages 14 to 15 for communications distance specifications. The communications distance will depend on the ID Tags, ambient temperature, surrounding metal, noise, and other factors. Test operation completely when installing a system.

V680-HS52 (embedded in non-metallic material) & V680-D2KF52M

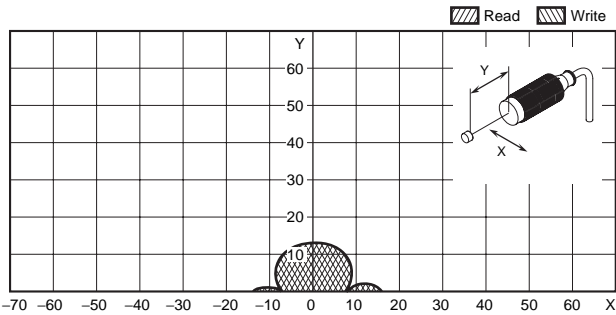

V680-HS52 (embedded in non-metallic material) & V680-D2KF52M (embedded in metallic surface: steel)

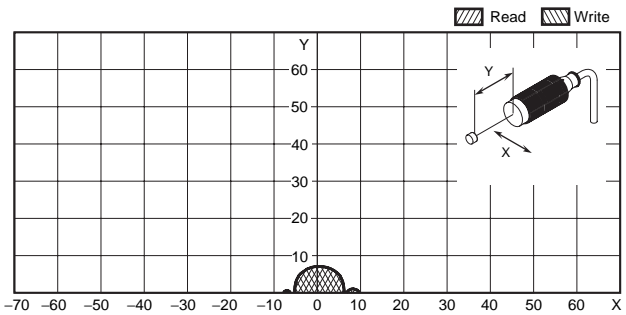

V680-HS51 (embedded in metallic material) & V680-D2KF52M

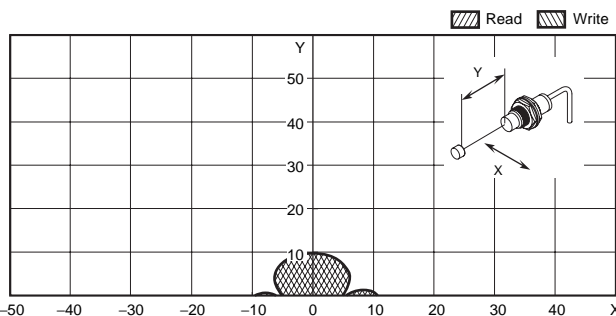

V680-HS51 (embedded in metallic material) & V680-D2KF52M (embedded in metallic surface: steel)

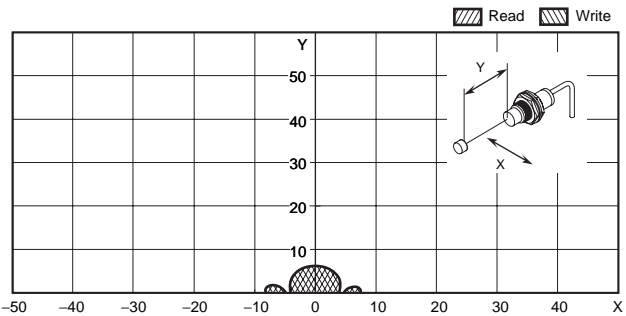

V680-HS63 (mounted on non-metallic material) & V680-D2KF52M

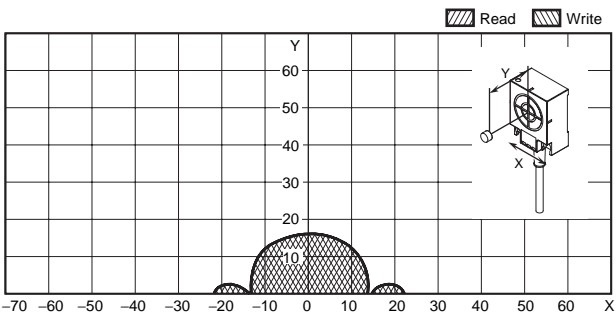

V680-HS52 (embedded in metallic material) & V680-D2KF67

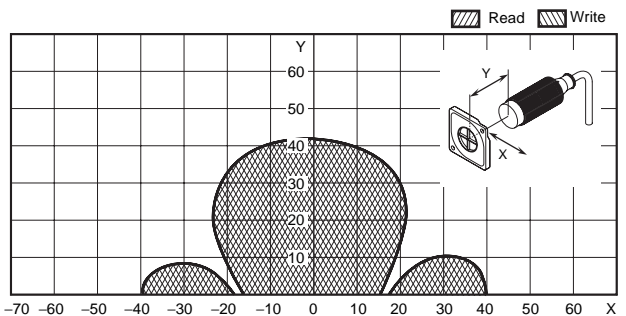

V680-HS63 (mounted on non-metallic material) & V680-D2KF67

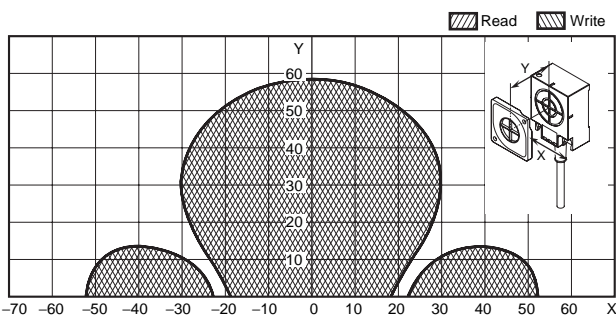

V680-HS65 (mounted on metallic material) & V680-D2KF67

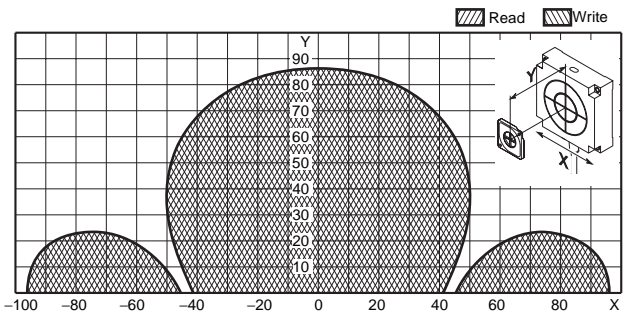

V680-HS52 (embedded in non-metallic material) & V680-D2KF67M (flush-mounted on metallic surface: steel)

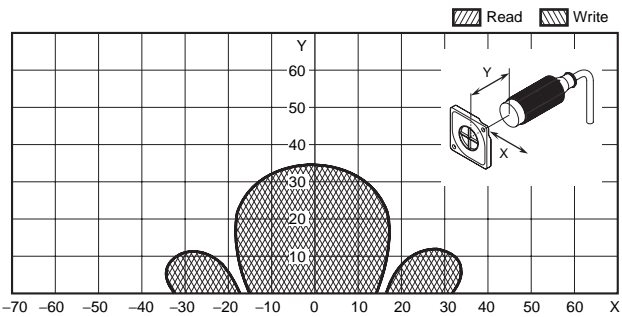

V680-HS63 (mounted on non-metallic material) & V680-D2KF67M (flush-mounted on metallic surface: steel)

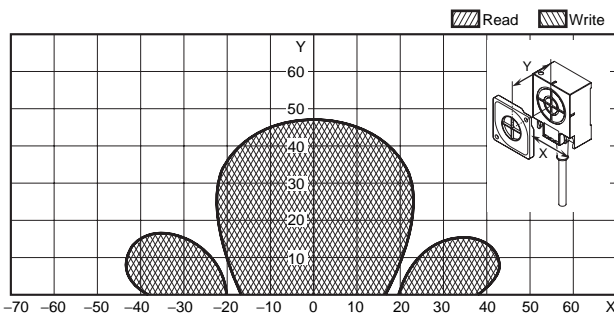

V680-HS65 (mounted on metallic material) & V680-D2KF67M (flush-mounted on metallic surface: steel)

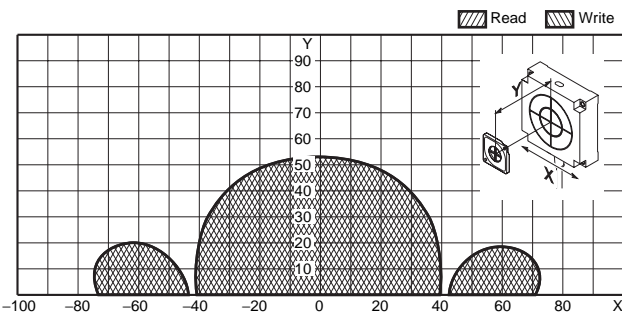

8-/32-Kbyte Memory ID Tag

The values given for communications ranges are reference values. Refer to pages 15 for communications distance specifications. The communications distance will depend on the ID Tags, ambient temperature, surrounding metal, noise, and other factors. Test operation completely when installing a system.

V680-HS63 (mounted on metallic material) & V680-D8KF68/-D32KF68 (Horizontal-facing ID Tag)

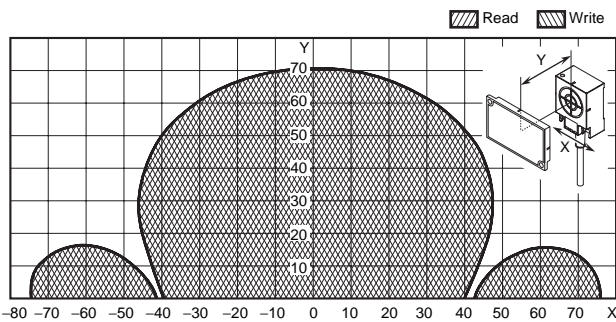

V680-HS63 (mounted on metallic material) & V680-D8KF68/-D32KF68 (Vertical-facing ID Tag)

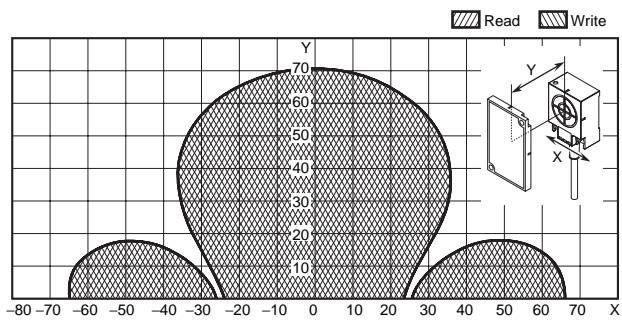

V680-HS63 (mounted on metallic material) & V680-D8KF68/-D32KF68 Flush-mounted on metallic surface: steel (Horizontal-facing ID Tag) When the V680-A81 ID Tag Attachment is mounted.

V680-HS63 (mounted on metallic material) & V680-D8KF68/-D32KF68 Flush-mounted on metallic surface: steel (Vertical-facing ID Tag) When the V680-A81 ID Tag Attachment is mounted.

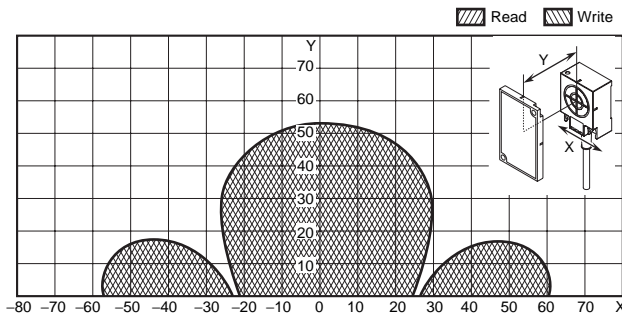
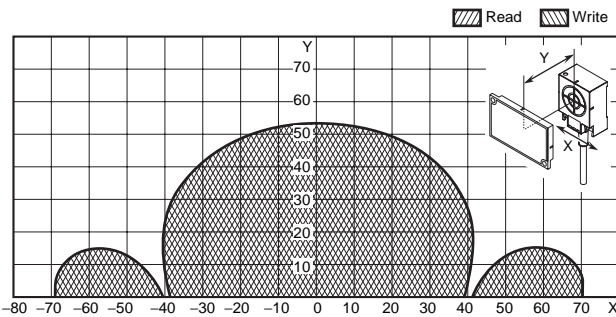

V680-HS65 (mounted on metallic material) & V680-D8KF68/-D32KF68 (Horizontal-facing ID Tag)

V680-HS65 (mounted on metallic material) & V680-D8KF68/-D32KF68 (Vertical-facing ID Tag)

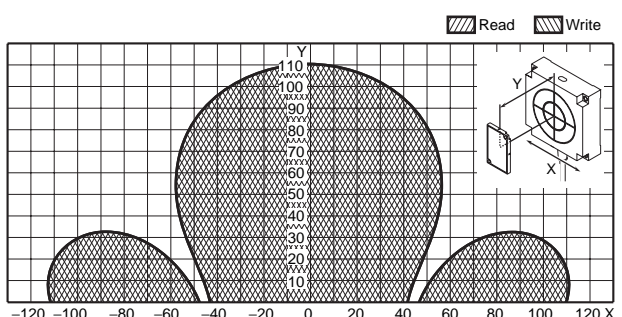
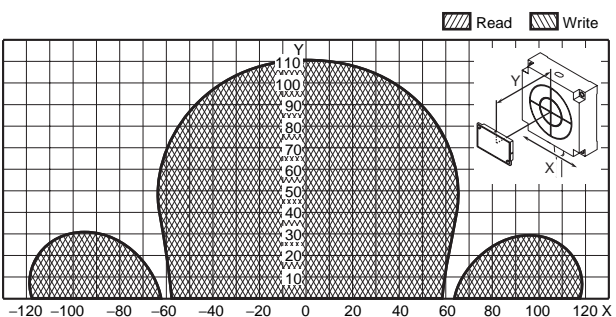

V680-HS65 (mounted on metallic material) & V680-D8KF68/-D32KF68 Flush-mounted on metallic surface: steel (Horizontal-facing ID Tag) When the V680-A81 ID Tag Attachment is mounted.

V680-HS65 (mounted on metallic material) & V680-D8KF68/-D32KF68 Flush-mounted on metallic surface: steel (Vertical-facing ID Tag) When the V680-A81 ID Tag Attachment is mounted.

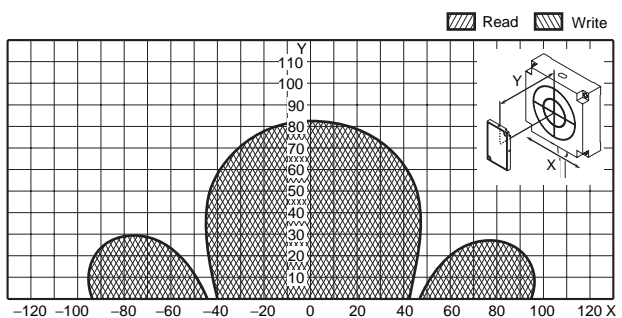
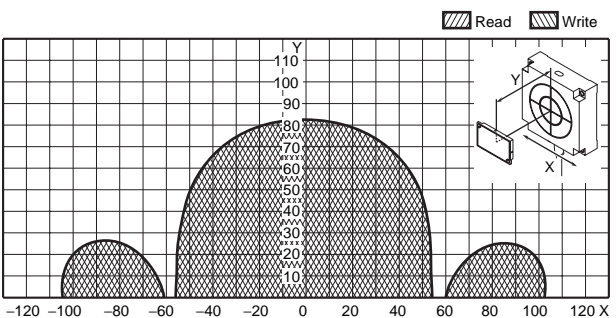

Processing Times (for reference purposes only)

Communications times between the Antenna and ID Tag, plus the processing time for the Amplifier.

V680-HAM42-DRT (DeviceNet ID Slave)

1-Kb Memory Tag

V680-D1KP□ (V680-HS□□ Antenna)

Communications speed setting	Command	Communications time (ms)			
		4-byte Access Mode	26-byte Access Mode	58-byte Access Mode	V600-compatible Mode
Normal mode	Read	67	95	137	67
	Write (with verification)	105	143	210	105
	Data Fill	17.5 × number of processed blocks + 89.2			---
High-speed mode	Read	63	85	117	---
	Write (with verification)	89	128	186	---
	Data Fill	14.8 × number of processed blocks + 71.7			---

2-Kb Memory Tag

V680-D2KF□ (V680-HS□□ Antenna)

Communications speed setting	Command	Communications time (ms)			
		4-byte Access Mode	26-byte Access Mode	58-byte Access Mode	V600-compatible Mode
Normal mode	Read	65	92	130	65
	Write (with verification)	105	142	219	105
	Data Fill	17.5 × number of processed blocks + 89.2			---
High-speed mode	Read	61	81	110	---
	Write (with verification)	86	124	178	---
	Data Fill	14.8 × number of processed blocks + 71.7			---

8 and 32-Kb Memory Tag

V680-D8KF68, V680-D32KF68 (V680-HS□□ Antenna)

Communications speed setting	Command	Communications time (ms)			
		4-byte Access Mode	26-byte Access Mode	58-byte Access Mode	V600-compatible Mode
Normal mode	Read	66	94	136	66
	Write (with verification)	96	131	182	96
	Data Fill	17.5 × number of processed blocks + 89.2			---
High-speed mode	Read	59	76	102	---
	Write (with verification)	76	100	135	---
	Data Fill	14.8 × number of processed blocks + 71.7			---

V680-HAM91/-HAM81 (ID Flag Sensor)

Model	V680-HAM91/V680-HAM81	
	Read	Write
	Data Read Verify Read	Write BIT SET BIT CLEAR
1-Kb, 2-Kb Memory Tag	43 ms	87 ms
8-Kb, 32-Kb Memory Tag	50 ms	84 ms

$$\text{ID Tag travel speed (i.e., conveyor speed)} = \frac{\text{Travel distance (D) in communications area}}{\text{Communications time (T)}}$$

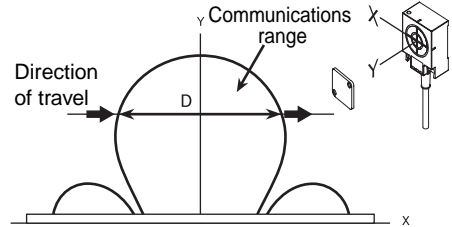

Calculation Example:

In this example, the V680-D1KP66T and V680-HS63 are combined and read together.

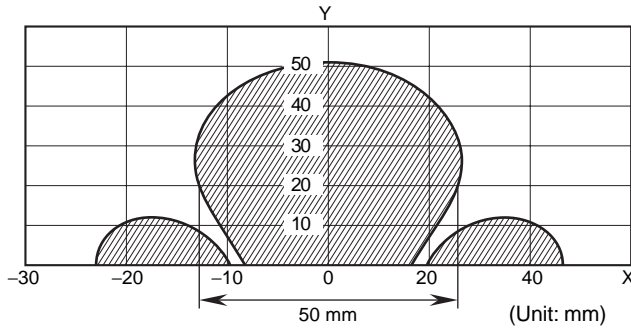

$$\text{ID Tag travel speed (m/min.)} = \frac{50 \text{ (mm)}}{43 \text{ (ms)}} \doteq 69 \text{ (m/min)}$$

- Note 1.** The travel speed depends on communications distance Y and axis offset. It is recommended to refer to the communications area diagram and use the part with the widest area.
- 2.** These values are guidelines. Perform testing with the actual device before operation.
- 3.** Processing for communications errors is not included in this formula.

Safety Precautions

⚠ WARNING

Do not use this product as a detection device to protect people.



Note: This catalog is intended only to help select the appropriate product. Be sure to read the User's Manual for usage precautions prior to using the product.

Precautions for Safe Use

To ensure safety, be sure to follow the following precautions:

1. Do not operate this product in any flammable, explosive, or corrosive gas environment.
2. Do not disassemble, repair, or remodel this product.
3. If any cable has a locking mechanism, be sure to check that it has been locked before using it.
4. The DC power supply must be within the specified rating (24 VDC +10%/–15%).
5. Do not reverse the power supply connection.
6. Do not insert water, wire, etc., into any of the gaps in the case. Doing so may cause fire or electric shock.
7. Make sure that the Unit is provided with sufficient ventilation space.
8. Do not install the Products near any equipment that generates a large amount of heat (such as heaters, transformers, and large-capacity resistors).
9. Turn OFF the Controller or ID Sensor Unit power before attaching or removing the Read/Write Antenna.
10. In the event that the product exhibits any abnormal condition, immediately stop using the system, turn OFF the power, and contact your OMRON sales representative.
11. Dispose of this product as industrial waste.
12. Do not clean the Products with paint thinner, benzene, acetone, or kerosene.
13. If multiple Antennas are mounted near each other, communications performance may decrease due to mutual interference. Refer to the *User's Manual* (Cat. No. Z278 or Z279) and check to make sure there is no mutual interference between the Antennas.
14. To remove the Unit, catch a tool on the hook and gently remove the Unit.
15. Do not perform wiring incorrectly or short-circuit the load. Doing so may result in rupture or damage from burning.
16. Do not use the product in environments subject to oil.
17. Do not use the product with an AC power supply.

Precautions for Correct Use

Please observe the following precautions to prevent failure to operate, malfunctions, or undesirable effects on product performance.

Installation Site

Install the product at a location where:

- It is not exposed to corrosive gases, dust, metal chips, or salt.
- The ambient operating temperature is within the range stipulated in the specifications.
- There are no sudden variations in temperature (no condensation).
- The ambient operating humidity is within the range stipulated in the specifications.
- No vibration or shock exceeding the values stipulated in the specifications is transmitted directly to the body of the product.
- It is not subject to splashing water, oil, or chemical substances.

Installation

- The product uses the 13.56-MHz frequency band to communicate with ID Tags. Some devices, such as some motors, inverters, and switching power supplies, generate electromagnetic waves (i.e., noise) that can affect communications with ID Tags. If any of these devices are nearby, communications with ID Tags may be affected or ID Tags may be destroyed. If the product is to be used near such devices, check the effects on communications before using the product.
- To minimize the general influence of noise, observe the following precautions:
 1. Ground any metallic material located around this device to 100 Ω or less.
 2. Keep the product away from high voltage and heavy current.
- Always bundle the cables connected to the power supply terminals and the ground terminal and connect the enclosed ferrite core (ZCAT2032-0930 manufactured by TDK) (V680-HAM42-DRT only).
- Do not pull on the cables with excessive strength.
- Do not use products that are not waterproof in misty environments.
- Do not subject the products to chemicals that adversely affect product materials.
- When installing the product, tighten screws to the following torque:
 - V680-HS51 Read/Write Antenna: 6 N-m
 - V680-HS52 Read/Write Antenna: 40 N-m
 - V680-HS63 Read/Write Antenna: 1.2 N-m
 - V680-HS65 Read/Write Antenna: 0.7 to 1.2 N-m
- When Read/Write Antennas are mounted side-by-side, mutual interference may reduce the transmission performance. Refer to the *RFID System Amplifier and Antennas/ID Tags User's Manual* to mount them in a way that will prevent mutual interference.

Host Communications (V680-HAM91/-HAM81)

When the Product is started, unstable signals may be output from the host interface.

Begin performing controls with the Product only after it has been started for at least 1 second.

Storage

Store the product at a location where:

- It is not exposed to corrosive gases, dust, metal chips, or salt.
- The ambient storage temperature is within the range stipulated in the specifications.
- There are no sudden variations in temperature (no condensation).
- The ambient storage humidity is within the range stipulated in the specifications.
- No vibration or shock exceeding the values stipulated in the specifications is transmitted directly to the body of the product.
- It is not subject to splashing water, oil, or chemical substances.

Cleaning

Do not use thinner, benzene, acetone, or kerosene for cleaning. Using these substances may dissolve the resin material and the case.

Dimensions

Note: All units are in millimeters unless otherwise indicated.

ID Tag

V680-D1KP52MT/-D2KF52M

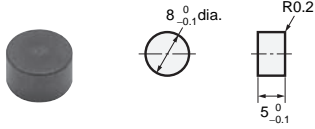

Case material	PPS resin
Filling	Epoxy resin

V680-D1KP66T/-D1KP66MT

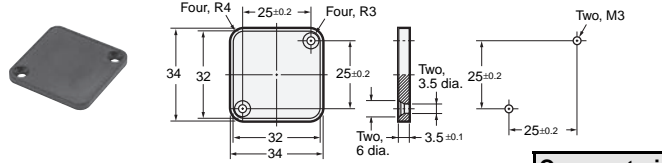

Case material	PPS resin
---------------	-----------

V680-D1KP66T-SP

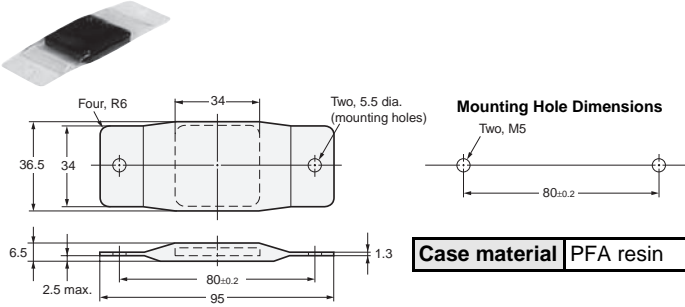

Case material	PFA resin
---------------	-----------

V680-D2KF67/-D2KF67M

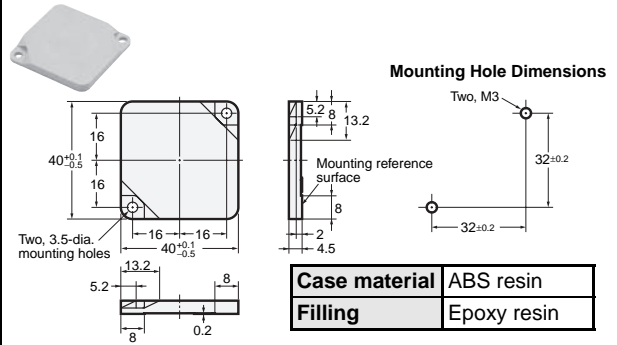

Case material	ABS resin
Filling	Epoxy resin

V680-D8KF68/-D32KF68

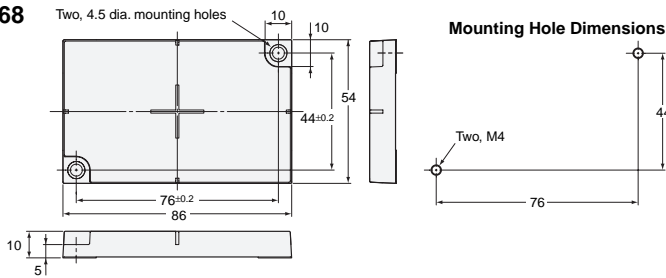

Case material	PBT resin
Filling	Epoxy resin

Read/Write Antenna with Detachable Amplifier Unit

V680-HS52-W

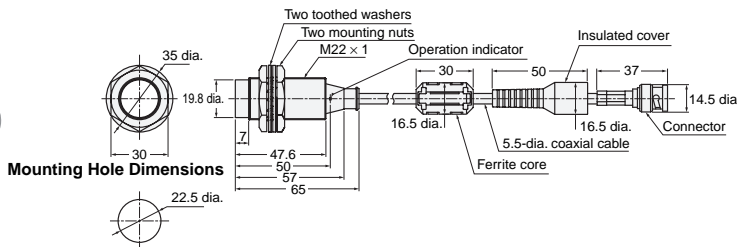

Case material	Brass
Transmission surface	PBT resin
Filling	Epoxy resin
Cable	PVC

V680-HS52-R

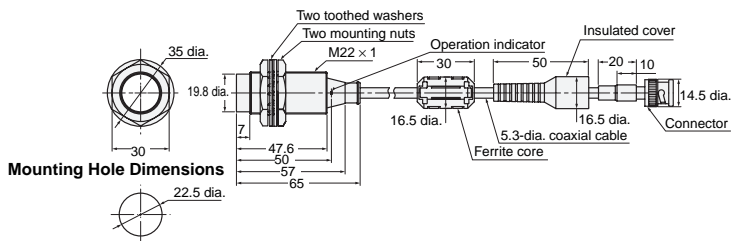

Case material	Brass
Transmission surface	PBT resin
Filling	Epoxy resin
Cable	PVC

V680-HS51

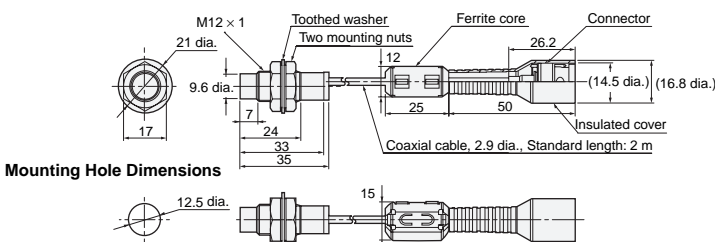

Case material	Brass
Transmission surface	ABS resin
Filling	Epoxy resin
Cable	PVC

V680-HS63-W

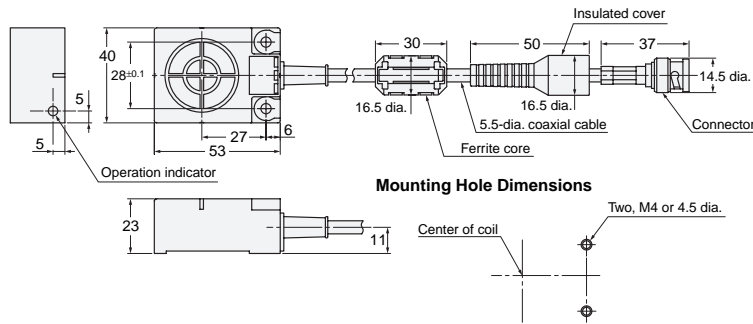

Case material	ABS resin
Filling	Epoxy resin
Cable	PVC

V680-HS63-R

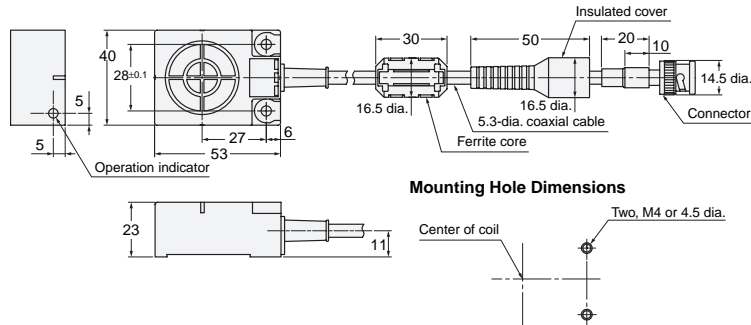

Case material	ABS resin
Filling	Epoxy resin
Cable	PVC

V680-HS65-W

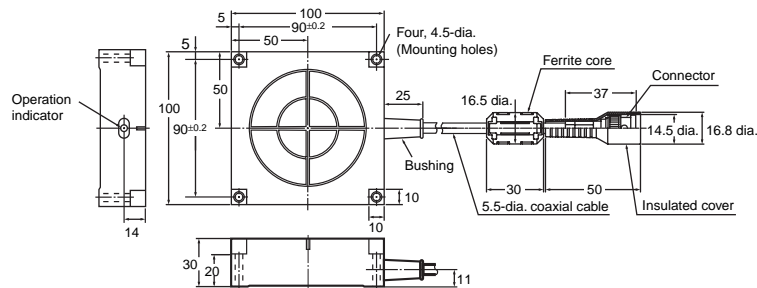

Case material	ABS resin
Filling	Epoxy resin
Cable	PVC (gray)

V680-HS65-R

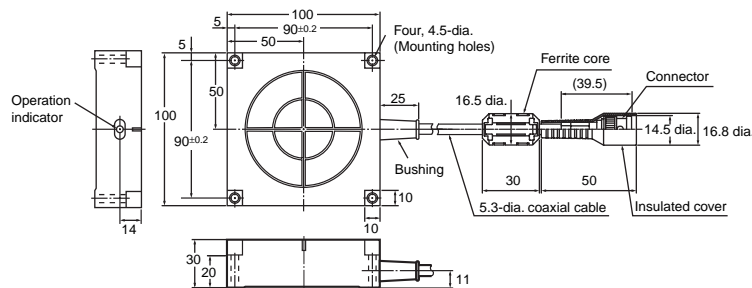

Case material	ABS resin
Filling	Epoxy resin
Cable	PVC (black)

Amplifier: DeviceNet ID Slave

V680-HAM42-DRT

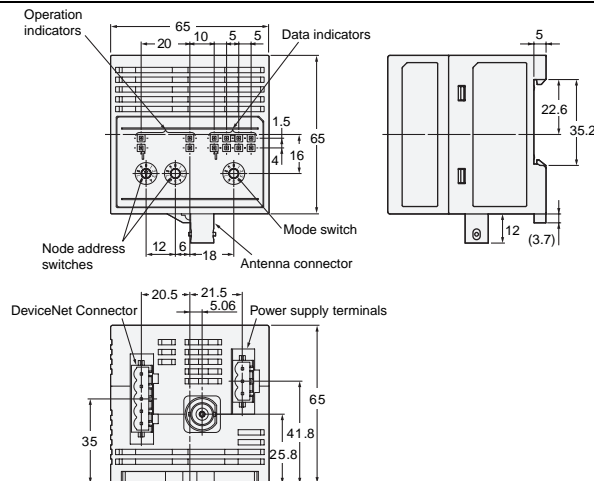

Case material	PC+ABS resin
----------------------	--------------

Amplifier: ID Flag Sensor

V680-HAM91/-HAM81

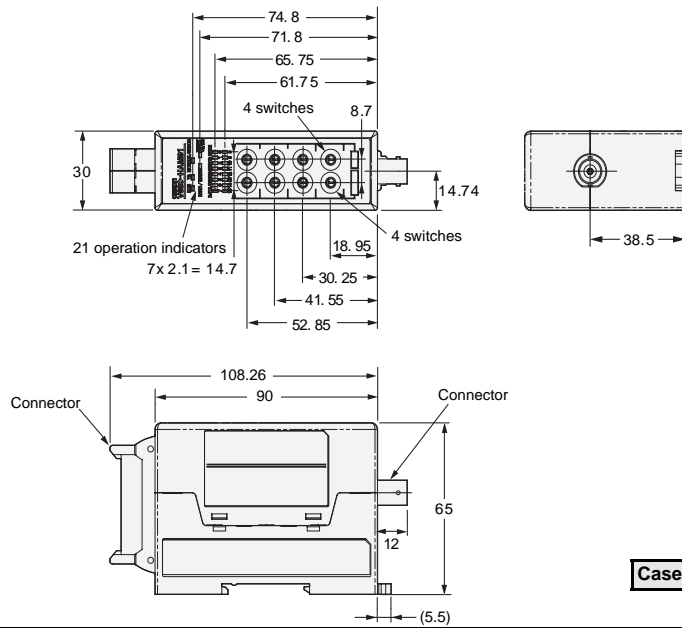

Case material	PC+ABS resin
---------------	--------------

Interface Cable (Order Separately)

V680-A60 2M/5M/10M

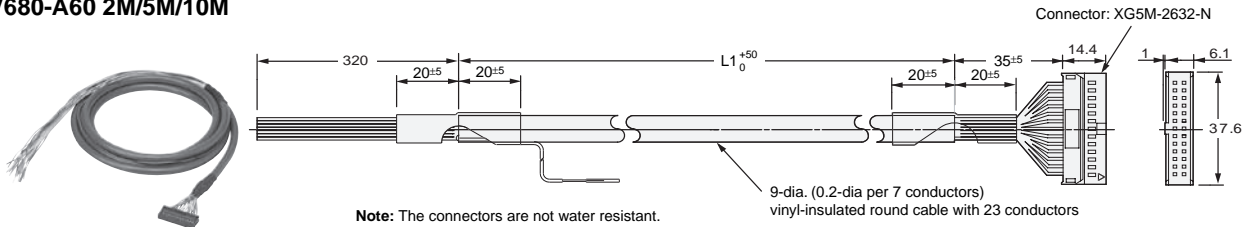

Note: The connectors are not water resistant.

Model	Length L1 (mm)
V680-A60 2M	2,000 mm
V680-A60 5M	5,000 mm
V680-A60 10M	10,000 mm

Accessory

V680-D1KP66T Attachments

V600-A86 Holder

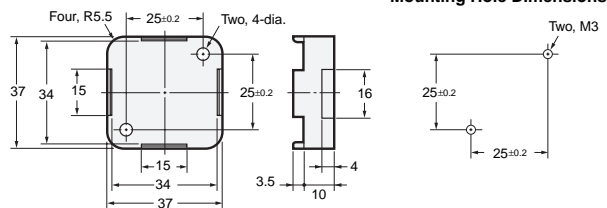
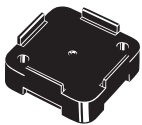

Case material	PPS resin
---------------	-----------

V680-D8KF68/-D32KF68 Attachments

V600-A81 Holder

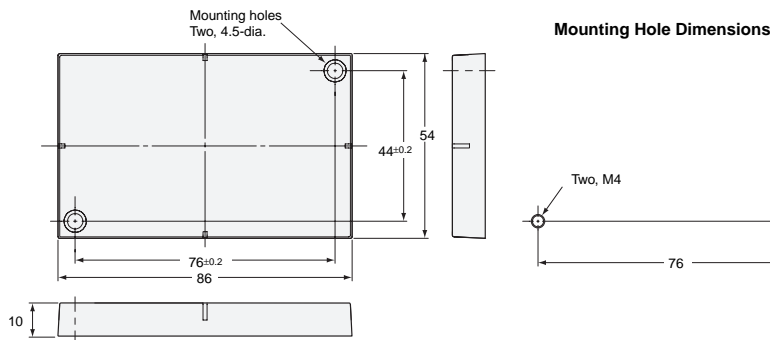

Case material	PBT resin
Filling	Epoxy resin

READ AND UNDERSTAND THIS DOCUMENT

Please read and understand this document before using the products. Please consult your OMRON representative if you have any questions or comments.

WARRANTY

OMRON's exclusive warranty is that the products are free from defects in materials and workmanship for a period of one year (or other period if specified) from date of sale by OMRON.

OMRON MAKES NO WARRANTY OR REPRESENTATION, EXPRESS OR IMPLIED, REGARDING NON-INFRINGEMENT, MERCHANTABILITY, OR FITNESS FOR PARTICULAR PURPOSE OF THE PRODUCTS. ANY BUYER OR USER ACKNOWLEDGES THAT THE BUYER OR USER ALONE HAS DETERMINED THAT THE PRODUCTS WILL SUITABLY MEET THE REQUIREMENTS OF THEIR INTENDED USE. OMRON DISCLAIMS ALL OTHER WARRANTIES, EXPRESS OR IMPLIED.

LIMITATIONS OF LIABILITY

OMRON SHALL NOT BE RESPONSIBLE FOR SPECIAL, INDIRECT, OR CONSEQUENTIAL DAMAGES, LOSS OF PROFITS OR COMMERCIAL LOSS IN ANY WAY CONNECTED WITH THE PRODUCTS, WHETHER SUCH CLAIM IS BASED ON CONTRACT, WARRANTY, NEGLIGENCE, OR STRICT LIABILITY.

In no event shall responsibility of OMRON for any act exceed the individual price of the product on which liability is asserted.

IN NO EVENT SHALL OMRON BE RESPONSIBLE FOR WARRANTY, REPAIR, OR OTHER CLAIMS REGARDING THE PRODUCTS UNLESS OMRON'S ANALYSIS CONFIRMS THAT THE PRODUCTS WERE PROPERLY HANDLED, STORED, INSTALLED, AND MAINTAINED AND NOT SUBJECT TO CONTAMINATION, ABUSE, MISUSE, OR INAPPROPRIATE MODIFICATION OR REPAIR.

SUITABILITY FOR USE

THE PRODUCTS CONTAINED IN THIS DOCUMENT ARE NOT SAFETY RATED. THEY ARE NOT DESIGNED OR RATED FOR ENSURING SAFETY OF PERSONS, AND SHOULD NOT BE RELIED UPON AS A SAFETY COMPONENT OR PROTECTIVE DEVICE FOR SUCH PURPOSES. Please refer to separate catalogs for OMRON's safety rated products.

OMRON shall not be responsible for conformity with any standards, codes, or regulations that apply to the combination of products in the customer's application or use of the product.

At the customer's request, OMRON will provide applicable third party certification documents identifying ratings and limitations of use that apply to the products. This information by itself is not sufficient for a complete determination of the suitability of the products in combination with the end product, machine, system, or other application or use.

The following are some examples of applications for which particular attention must be given. This is not intended to be an exhaustive list of all possible uses of the products, nor is it intended to imply that the uses listed may be suitable for the products:

- Outdoor use, uses involving potential chemical contamination or electrical interference, or conditions or uses not described in this document.
- Nuclear energy control systems, combustion systems, railroad systems, aviation systems, medical equipment, amusement machines, vehicles, safety equipment, and installations subject to separate industry or government regulations.
- Systems, machines, and equipment that could present a risk to life or property.

Please know and observe all prohibitions of use applicable to the products.

NEVER USE THE PRODUCTS FOR AN APPLICATION INVOLVING SERIOUS RISK TO LIFE OR PROPERTY WITHOUT ENSURING THAT THE SYSTEM AS A WHOLE HAS BEEN DESIGNED TO ADDRESS THE RISKS, AND THAT THE OMRON PRODUCT IS PROPERLY RATED AND INSTALLED FOR THE INTENDED USE WITHIN THE OVERALL EQUIPMENT OR SYSTEM.

PERFORMANCE DATA

Performance data given in this document is provided as a guide for the user in determining suitability and does not constitute a warranty. It may represent the result of OMRON's test conditions, and the users must correlate it to actual application requirements. Actual performance is subject to the OMRON Warranty and Limitations of Liability.

CHANGE IN SPECIFICATIONS

Product specifications and accessories may be changed at any time based on improvements and other reasons.

It is our practice to change model numbers when published ratings or features are changed, or when significant construction changes are made. However, some specifications of the product may be changed without any notice. When in doubt, special model numbers may be assigned to fix or establish key specifications for your application on your request. Please consult with your OMRON representative at any time to confirm actual specifications of purchased products.

DIMENSIONS AND WEIGHTS

Dimensions and weights are nominal and are not to be used for manufacturing purposes, even when tolerances are shown.

ERRORS AND OMISSIONS

The information in this document has been carefully checked and is believed to be accurate; however, no responsibility is assumed for clerical, typographical, or proofreading errors, or omissions.

PROGRAMMABLE PRODUCTS

OMRON shall not be responsible for the user's programming of a programmable product, or any consequence thereof.

COPYRIGHT AND COPY PERMISSION

This document shall not be copied for sales or promotions without permission.

This document is protected by copyright and is intended solely for use in conjunction with the product. Please notify us before copying or reproducing this document in any manner, for any other purpose. If copying or transmitting this document to another, please copy or transmit it in its entirety.

ALL DIMENSIONS SHOWN ARE IN MILLIMETERS.

To convert millimeters into inches, multiply by 0.03937. To convert grams into ounces, multiply by 0.03527.

OMRON Corporation Industrial Automation Company

Tokyo, JAPAN

Contact: www.ia.omron.com

Regional Headquarters

OMRON EUROPE B.V.
Sensor Business Unit
 Carl-Benz-Str. 4, D-71154 Nufringen, Germany
 Tel: (49) 7032-811-0/Fax: (49) 7032-811-199

OMRON ELECTRONICS LLC
 One Commerce Drive Schaumburg,
 IL 60173-5302 U.S.A.
 Tel: (1) 847-843-7900/Fax: (1) 847-843-7787

OMRON ASIA PACIFIC PTE. LTD.
 No. 438A Alexandra Road # 05-05/08 (Lobby 2),
 Alexandra Technopark,
 Singapore 119967
 Tel: (65) 6835-3011/Fax: (65) 6835-2711

OMRON (CHINA) CO., LTD.
 Room 2211, Bank of China Tower,
 200 Yin Cheng Zhong Road,
 PuDong New Area, Shanghai, 200120, China
 Tel: (86) 21-5037-2222/Fax: (86) 21-5037-2200

Authorized Distributor:

© OMRON Corporation 2009 All Rights Reserved.
 In the interest of product improvement,
 specifications are subject to change without notice.

Cat. No. Q160-E1-01A

Printed in Japan
 0308 (0308) (C)

Mouser Electronics

Authorized Distributor

Click to View Pricing, Inventory, Delivery & Lifecycle Information:

Omron:

[V680-D1KP52MT](#)



**Стандарт
Электрон
Связь**

Мы молодая и активно развивающаяся компания в области поставок электронных компонентов. Мы поставляем электронные компоненты отечественного и импортного производства напрямую от производителей и с крупнейших складов мира.

Благодаря сотрудничеству с мировыми поставщиками мы осуществляем комплексные и плановые поставки широчайшего спектра электронных компонентов.

Собственная эффективная логистика и склад в обеспечивает надежную поставку продукции в точно указанные сроки по всей России.

Мы осуществляем техническую поддержку нашим клиентам и предпродажную проверку качества продукции. На все поставляемые продукты мы предоставляем гарантию .

Осуществляем поставки продукции под контролем ВП МО РФ на предприятия военно-промышленного комплекса России , а также работаем в рамках 275 ФЗ с открытием отдельных счетов в уполномоченном банке. Система менеджмента качества компании соответствует требованиям ГОСТ ISO 9001.

Минимальные сроки поставки, гибкие цены, неограниченный ассортимент и индивидуальный подход к клиентам являются основой для выстраивания долгосрочного и эффективного сотрудничества с предприятиями радиоэлектронной промышленности, предприятиями ВПК и научно-исследовательскими институтами России.

С нами вы становитесь еще успешнее!

Наши контакты:

Телефон: +7 812 627 14 35

Электронная почта: sales@st-electron.ru

Адрес: 198099, Санкт-Петербург,
Промышленная ул, дом № 19, литера Н,
помещение 100-Н Офис 331