

NB4N121KMNGEVB

NB4N121KMNGEVB Evaluation Board User's Manual

Board Name: NB4N121KMNGEVB
Device Name: NB4N121KMN



ON Semiconductor®

<http://onsemi.com>

Eval Board User's Manual

Description

The NB4N121K Evaluation Board was designed to provide a flexible and convenient platform to quickly evaluate, characterize and verify the performance and operation of the device under test NB4N121K.

The NB4N121K is a Clock differential input fanout distribution device with 1 to 21 HCSL level differential outputs, optimized for ultra low propagation delay variation. The NB4N121K is designed with HCSL clock distribution for FBDIMM applications in mind. Inputs can accept differential LVPECL, CML, or LVDS levels. Single-ended LVPECL, CML, LVCMOS or LVTTL levels are accepted with the proper V_{REFAC} supply. Clock input pins incorporate an internal $50\ \Omega$ on die termination resistors. Output drive current at I_{REF} (Pin 1) for 1X load is selected by connecting a $0\ k\Omega$ to $1\ k\Omega$ external resistor to GND. To drive a 2X load, connect the I_{REF} Pin 1 through $20\ k\Omega$ to $50\ k\Omega$ external resistors. The NB4N121K specifically guarantees low output-to-output skews. Optimal design, layout, and processing minimize skew within a device and from device to device. System designers can take advantage of the NB4N121K's performance to distribute low skew clocks across the backplane or the motherboard. The device is packaged in a low profile $8\ x\ 8\ mm$ 52-pin QFN package.

This user's manual provides detailed information on the board's contents, layout and use. The manual should be used in conjunction with the NB4N121K data sheet which contains full technical details on device specifications and operation.

Board Features

- Fully assembled evaluation board with Device-Under-Test (DUT) soldered mounted. The device may be demounted and replaced by a test fixture socket (ANTARES Test Technology, P/N FP0052QN0805C, 3350 Scott Blvd., Bldg 58, Santa Clara, CA 95054, Phone: (408) 988-6800, www.antares-att.com.) for manual insertion of different sample device units.
- Accommodates the electrical characterization of the NB4N121K in the QFN52 package
- Equal length input and output data lines to minimize skew measurement calibration.
- Default 1X output drive ($50\ \Omega$ load) with optional 2X load capability ($25\ \Omega$ load) selectable by installing pulldown resistors and adjusting board R_{REF} setting on I_{REF} (pin1). Adjustable R_{REF} resistor potentiometer for fine tuning output drive current (amplitude) levels.
- Single + 3.3 V Operation for direct LOW Impedance probe connection ($50\ \Omega$ to GND).

Appendix 1: Device Information

Appendix 2: Schematics

Appendix 3: I_{REF} Pin Load Plot

Appendix 4: Bill of Materials, Board Stackup

NB4N121KMNGEVB

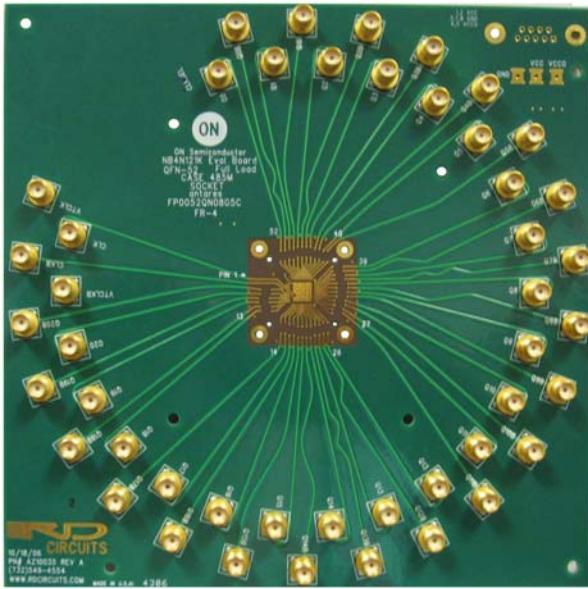

Board Map

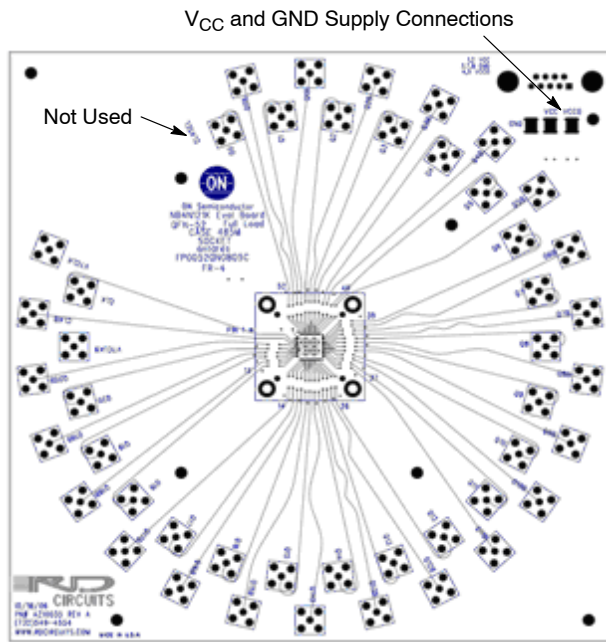

Figure 1. Front

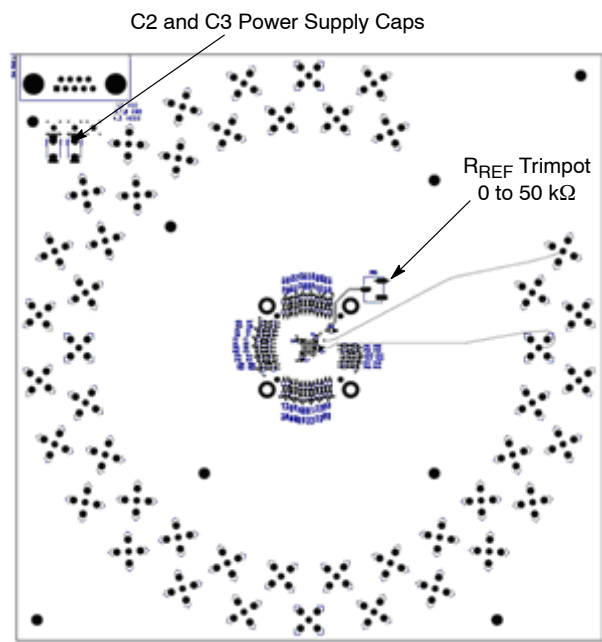

Figure 2. Back

Front Notes:

1. V_{CC0} and V_{CC} contacts must be ganged and connected together to the positive 3.3 V supply.
2. CLK_{SEL} is not used (no SMA).

Back Notes:

1. C2 and C3 are power supply caps
2. R_{REF} trimpot is connected from I_{REF} to GND to select output drive for 1X (0 to 1 k Ω ; Short to GND) or 2X loading (20 K to 50 k Ω ; Open or Short to V_{CC}). See Appendix 3: Device I_{REF} pin 1 load plot of R_{REF} vs. I_{REF} current

3. Back D.U.T. area detail: (See Figure 3) Odd numbered resistors R17 to R81 are populated for 1X load. Even numbered resistors are not populated. The even numbered resistors may be repopulated with 50 Ω (to GND) components to convert the board to 2X load use with 50 Ω scope input impedance loading (presents a 25 Ω parallel load to the device outputs). Even numbered “series shorting” resistors R17 to R81 are populated zero ohm value. These may be repopulated with a series resistor value to improve signal integrity. Components C1, C4, C5, C6, and C7 are 0.01 μ F bypass caps.

NB4N121KMNGEVB

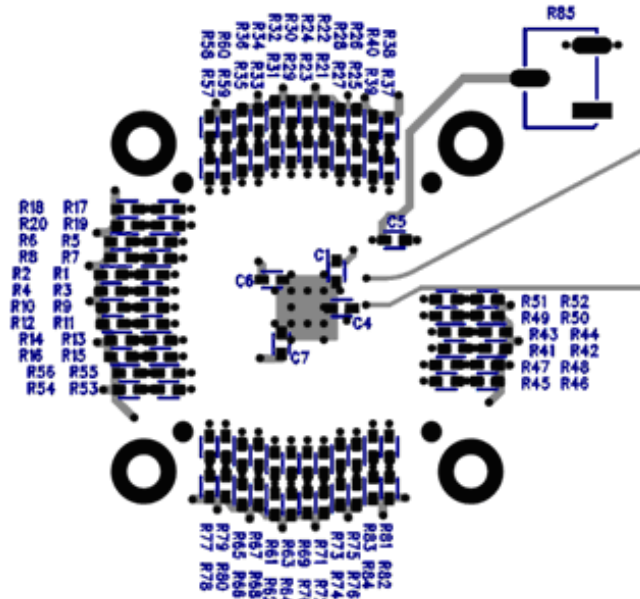

Figure 3. Back D.U.T. Area Detail

Test and Measurements Setup Details:

Step 1: Basic Equipment

- Signal Generator
- Oscilloscope
- Power Supply
- Voltmeter
- Matched High-Speed Coax Cables with SMA Connectors

Step 2: Board Test Connections Setup: (1X Load configuration, I_{REF} pin shorted to GND)

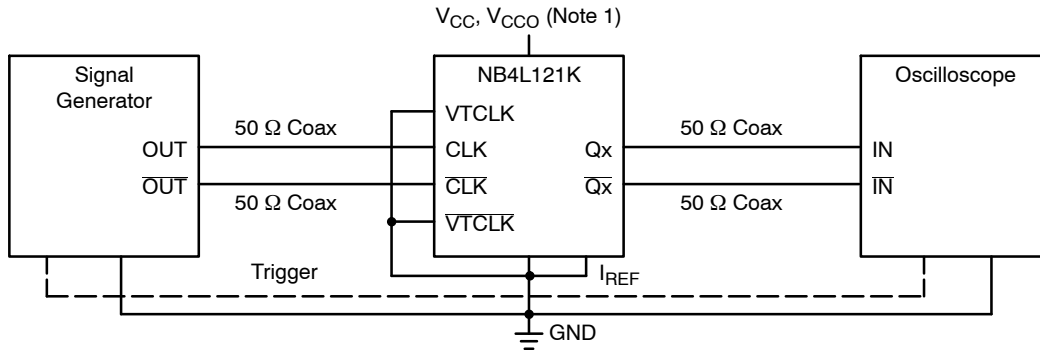

Figure 4. NB4N121KMNGEVB Evaluation Board Connector Configuration

Table 1. Power Supply Connections

Positive and GND supplies must be connected to anvil clips for proper operation. Bridge V_{CC} and V_{CCO} board connection together.

Board Connector Pin	Supply	Value	Device Pin
V_{CC} , V_{CCO} (Note 1)	V_{CC}	3.0 to 3.6 V	7, 26, 39, 52
GND	GND	0 V	2
I_{REF} (Note 2)	R_{REF} to GND	For 1x loading: 0 to 50 k Ω For 2x loading: 20 K to 50 k Ω	1
EXPOSED PAD Vias	GND	Thermal Conduit	Exposed Pad

1. Short together and connect to V_{CC} supply. See **Appendix 4: Board Lamination Stackup**
2. See **Appendix 3: Device I_{REF} pin 1 Load Plot of R_{REF} vs. I_{REF} Current**

NB4N121KMNGEVB

Table 1. Input/Output Board to Device Pin Connections

Board Connector	Device Pin Name	Device Pin
VTCLK	VTCLK	3
CLK	CLK	4
CLK	CLK	5
VTCLK	VTCLK	6
$\overline{Q20}$	$\overline{Q20}$	8
Q20	Q20	9
$\overline{Q19}$	$\overline{Q19}$	10
Q19	Q19	11
$\overline{Q18}$	$\overline{Q18}$	12
Q19	Q19	13
$\overline{Q17}$	$\overline{Q17}$	14
Q17	Q17	15
$\overline{Q16}$	$\overline{Q16}$	16
Q16	Q16	17
$\overline{Q15}$	$\overline{Q15}$	18
Q15	Q15	19
$\overline{Q14}$	$\overline{Q14}$	20
Q14	Q14	21
$\overline{Q13}$	$\overline{Q13}$	22
Q13	Q13	23
$\overline{Q12}$	$\overline{Q12}$	24
Q12	Q12	25
$\overline{Q11}$	$\overline{Q11}$	27
Q11	Q11	28
$\overline{Q10}$	$\overline{Q10}$	29
Q10	Q10	30
$\overline{Q9}$	$\overline{Q9}$	31
Q9	Q9	32
$\overline{Q8}$	$\overline{Q8}$	33
Q8	Q8	34
$\overline{Q7}$	$\overline{Q7}$	35
Q7	Q7	36
$\overline{Q6}$	$\overline{Q6}$	37
Q6	Q6	38
$\overline{Q5}$	$\overline{Q5}$	40
Q5	Q5	41
$\overline{Q4}$	$\overline{Q4}$	42
Q4	Q4	43
$\overline{Q3}$	$\overline{Q3}$	44
Q3	Q3	45
$\overline{Q2}$	$\overline{Q2}$	46
Q2	Q2	47
$\overline{Q1}$	$\overline{Q1}$	48
Q1	Q1	49
$\overline{Q0}$	$\overline{Q0}$	50
Q0	Q0	51

Input Pins and Signals

CLK and \overline{CLK} pins require differential LVPECL levels swinging around an acceptable common mode voltage per datasheet. Internal impedance matching resistor of 50 Ω is provided for driver termination from input pin to the respective VTx pin. Typically the VTx pins are connected to a VTT of $V_{CC}-2.0$ V. The differential inputs can be driven single ended per the datasheet.

Output Pins and Signals

Output pairs in use must always be balance in each pins loading and termination even if only one side of an output pair is delivered to receiver or scope. Do not unbalance an output pair by loading or probing only one line. Unused outputs should be left floating open. The Rs resistors values are zero Ω , but may be changed to value such as 6 to 12 Ω to improve signal integrity.

For 1X loading, set R_{REF} potentiometer between 0 and 1 k Ω to GND for 1X loading (see Appendix 1: Device I_{REF} pin 1 load plot of R_{REF} vs. I_{REF} current).

For 50 Ω (Low Impedance) probes with High Bandwidth (>1 GHz): The odd numbered Serial Resistors R17 to R81 positions are populated with zero Ω resistors. The even numbered Parallel Loading resistors R18 to R82 should not be populated (open). Scope module inputs will provide proper termination 50 Ω to GND. Un-probed outputs will need to be externally loaded with 50 Ω to GND for proper balanced operation.

For High Impedance Probes, low input capacitance probe with High Bandwidth (>1 GHz), odd numbered Series Resistors positions R17 to R81 are populated with 0 Ω value components. The even numbered Parallel Loading resistors R18 to R82 should also all be populated with 50 Ω (to GND) components for proper termination.

For 2X loading, set the R_{REF} between 20 K and 50 k Ω to GND or tie I_{REF} directly to V_{CC} .

For 50 Ω (Low Impedance) probes with High Bandwidth (>1 GHz), the odd numbered Serial Resistors R17 to R81 positions should be populated with zero Ω value components. All even numbered Parallel Loading resistors R18 to R82 should have 50 Ω value components installed. A typical scope (probe) 50 Ω impedance in parallel with the installed even numbered Parallel Loading 50 Ω resistors R18 to R82 will present a 25 Ω (2X) load to the device. Un-probed outputs will need to be externally loaded with 50 Ω to GND to present the proper 25 Ω load to the device.

For High Impedance Probes, low input capacitance probe with High Bandwidth (>1 GHz), odd numbered Series Resistors positions R17 to R81 are populated with 0 Ω value components. The even numbered Parallel Loading resistors R18 to R82 should also all be populated with 25 Ω (to GND) components for proper termination.

Low Impedance Probes:

Use 50 Ω (Low Impedance) probes with High Bandwidth (>1 GHz). The odd numbered Resistors R18 to R82 positions should be populated with 50 Ω value components.

NB4N121KMNGEVB

A typical scope (probe) 50 Ω impedance in parallel with the installed odd numbered 50 Ω Resistor value will present a 25 Ω load to the device. Un-probed outputs will need to be externally loaded with 25 Ω to GND for proper operation.

High Impedance Probes:

Use a high impedance, low input capacitance probe with High Bandwidth (>1 GHz) and repopulate odd numbered Resistors R18 to R82 (25 Ω value).

Step 3: Electrical Measurements

Device will meet the specifications after thermal equilibrium has been established when mounted in a test socket or printed circuit board with maintained transverse airflow greater than 500 l_{fpm}. Electrical parameters are guaranteed only over the declared operating temperature range. Functional operation of the device exceeding these conditions is not implied. Device specification limit values are applied individually under normal operating conditions and not valid simultaneously.

APPENDIXES

Appendix 1: Device Information

Device Under Test: NB4N121K
 Package Case Identification,
 Device Marking Diagram,
 Device Function Diagram,
 Output Loading Diagram,
 Pinout Diagram,
 Pin Description

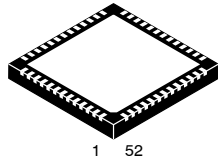

**QFN-52
 CASE 485M
 MN SUFFIX**

Figure 5. Package Case Identification

MARKING DIAGRAM

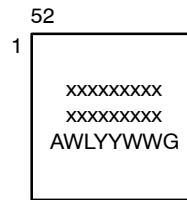

XXXXXXXXXX	= Device Code
A	= Assembly Site
WL	= Wafer Lot
YY	= Year
WW	= Work Week
G	= Pb-Free Package

Figure 6. Device Marking Diagram

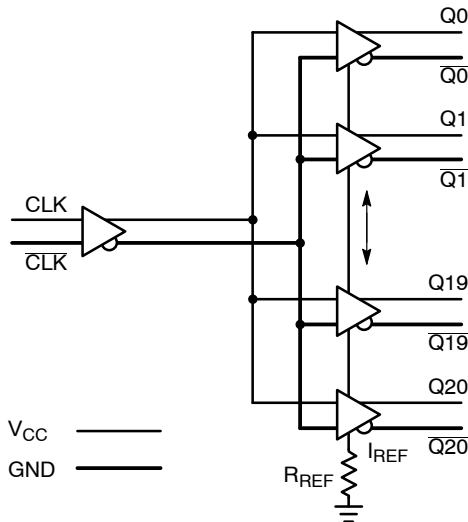

Figure 7. Device Function Diagram

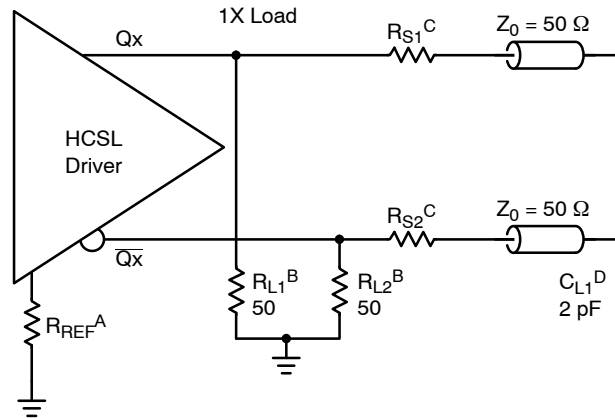

Figure 8. Output Loading Diagram

$R_{S1}^C = 0 \Omega$
 $R_{REF}^A = 0-1 \text{ k}\Omega$ for 1X Load, 20 K-50 K for 2X Load
 R_{LX}^B may be open for 1X load (supplied by scope input module), may be 50 Ω for 2X load to present a 25 Ω load with scope 50 Ω input module impedance.

NB4N121KMNGEVB

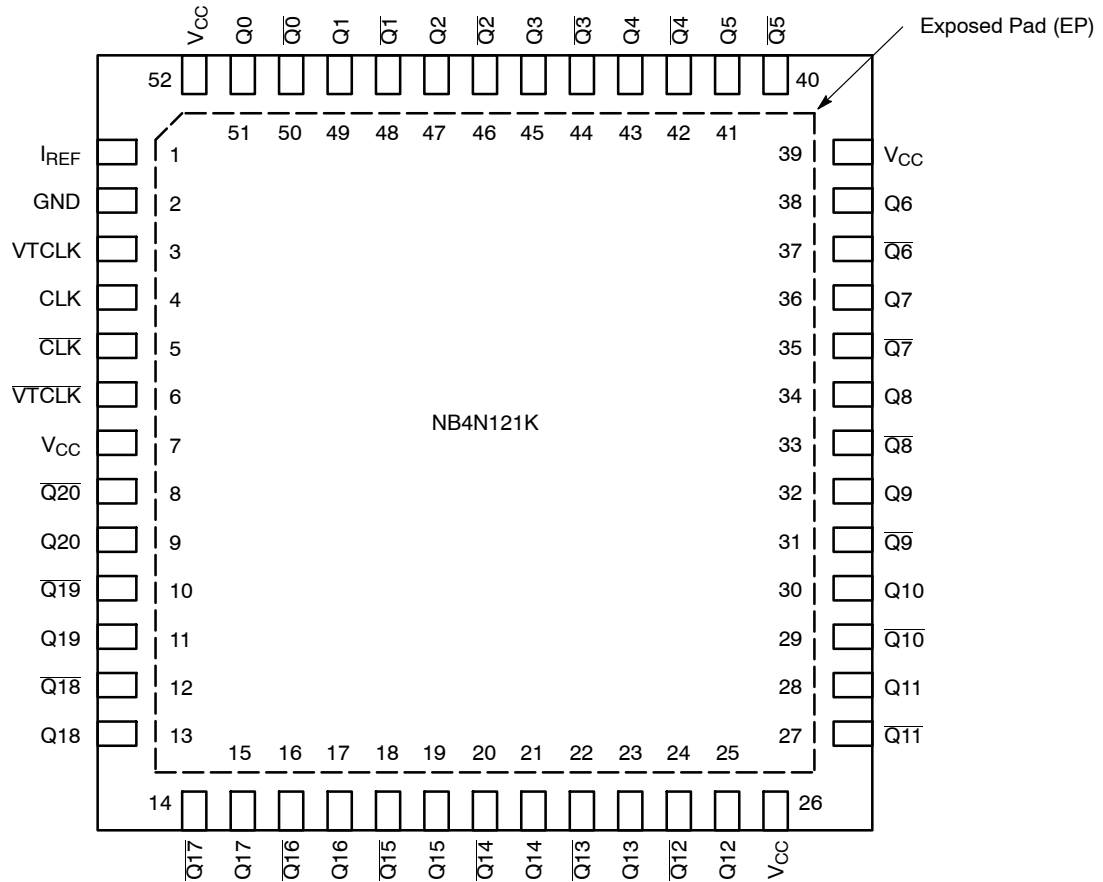

Figure 9. Pinout Diagram

Table 2. PIN DESCRIPTION

Pin	Name	I/O	Description
1	I _{REF}	Output	Output current programming pin to select 1X or 2X load. Connect a selected resistor from I _{REF} pin to GND (See Appendix 3: Device I _{REF} pin 1 load plot of R _{REF} vs. I _{REF} current.
2	GND	-	Supply Ground. GND pin must be externally connected to power supply to guarantee proper operation.
3, 6	VTCLK, VTCLK	-	Internal 50 Ω Termination Resistor connection Pins. In the differential configuration when the input termination pins are connected to the common termination voltage, and if no signal is applied then the device may be susceptible to self-oscillation.
4	CLK	LVPECL Input	CLOCK Input (TRUE)
5	CLK	LVPECL Input	CLOCK Input (INVERT)
7, 26, 39, 52	V _{CC}	-	Positive Supply pins. V _{CC} pins must be externally connected to a power supply to guarantee proper operation.
8, 10, 12, 14, 16, 18, 20, 22, 24, 27, 29, 31, 33, 35, 37, 40, 42, 44, 46, 48, 50	Q[20-0]	HCSL Output	Output (INVERT)
9, 11, 13, 15, 17, 19, 21, 23, 25, 28, 30, 32, 34, 36, 38, 41, 43, 45, 47, 49, 51	Q[20-0]	HCSL Output	Output (TRUE)
Exposed Pad	EP	GND	Exposed Pad. The thermally exposed pad (EP) on package bottom (see case drawing) must be attached to a sufficient heat-sinking conduit for proper thermal operation. (Note 1)

Appendix 2: Schematics

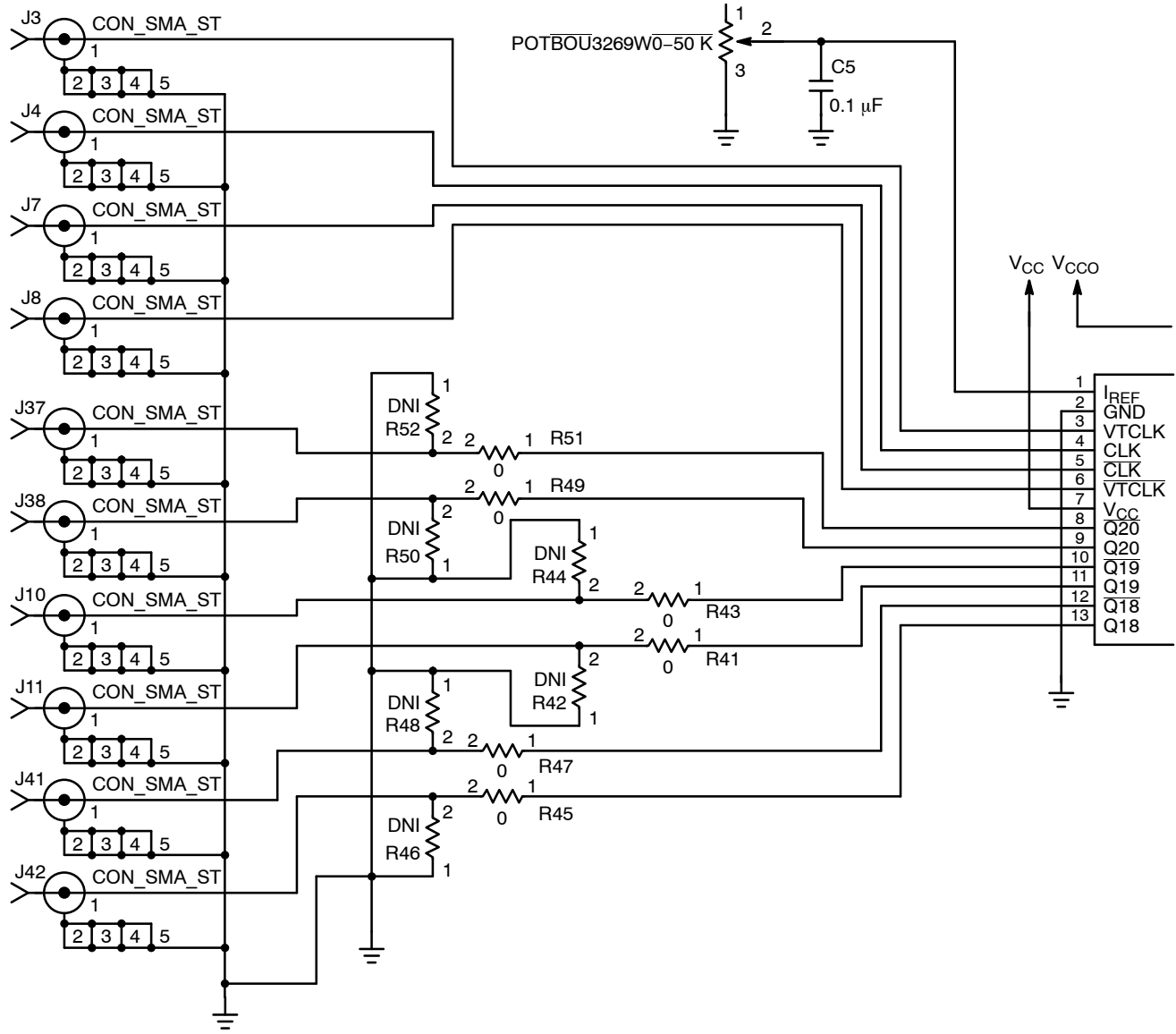

Figure 10. Pins 1 to 13

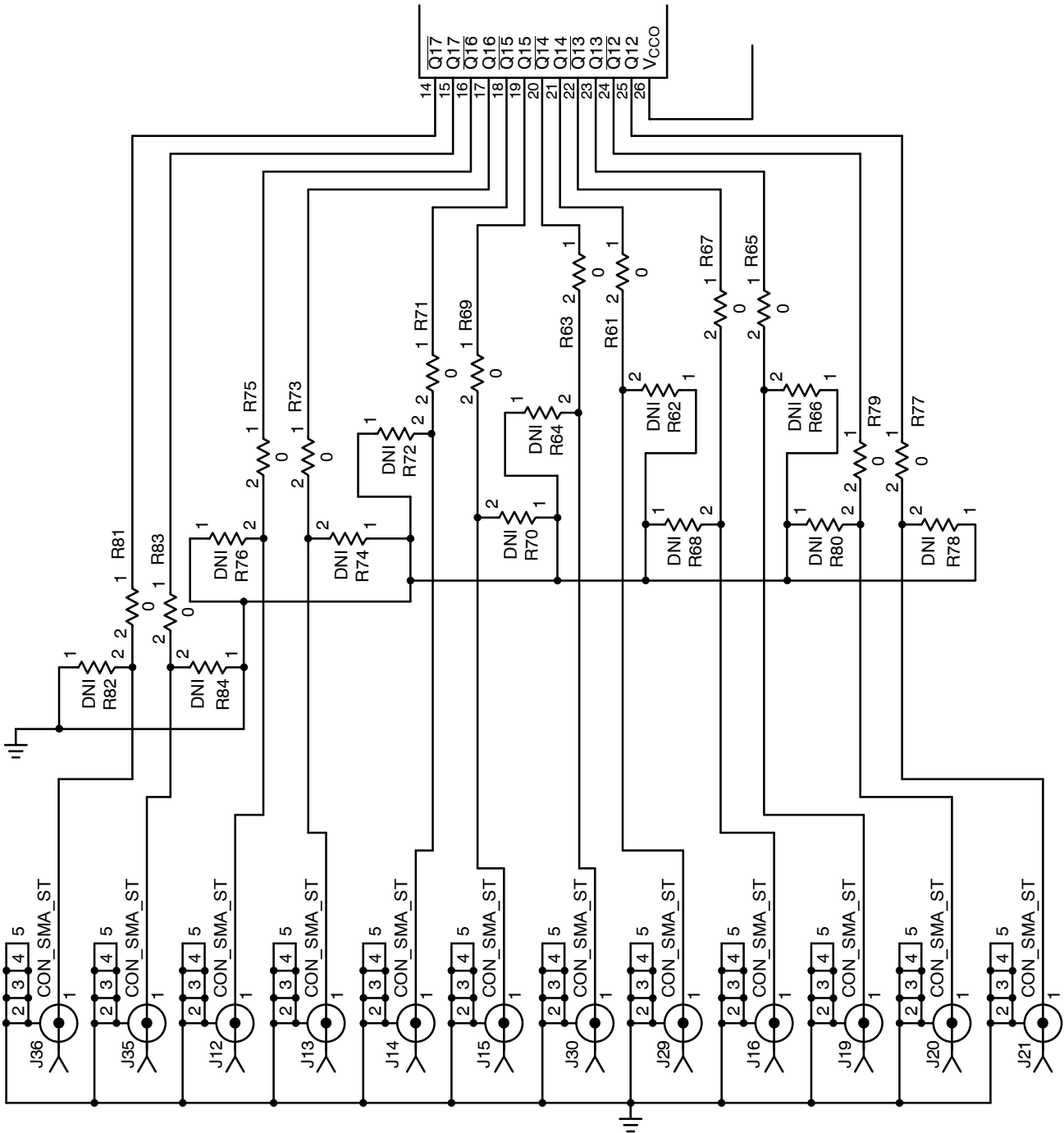

Figure 11. Pins 14 to 26

NB4N121KMNGEVB

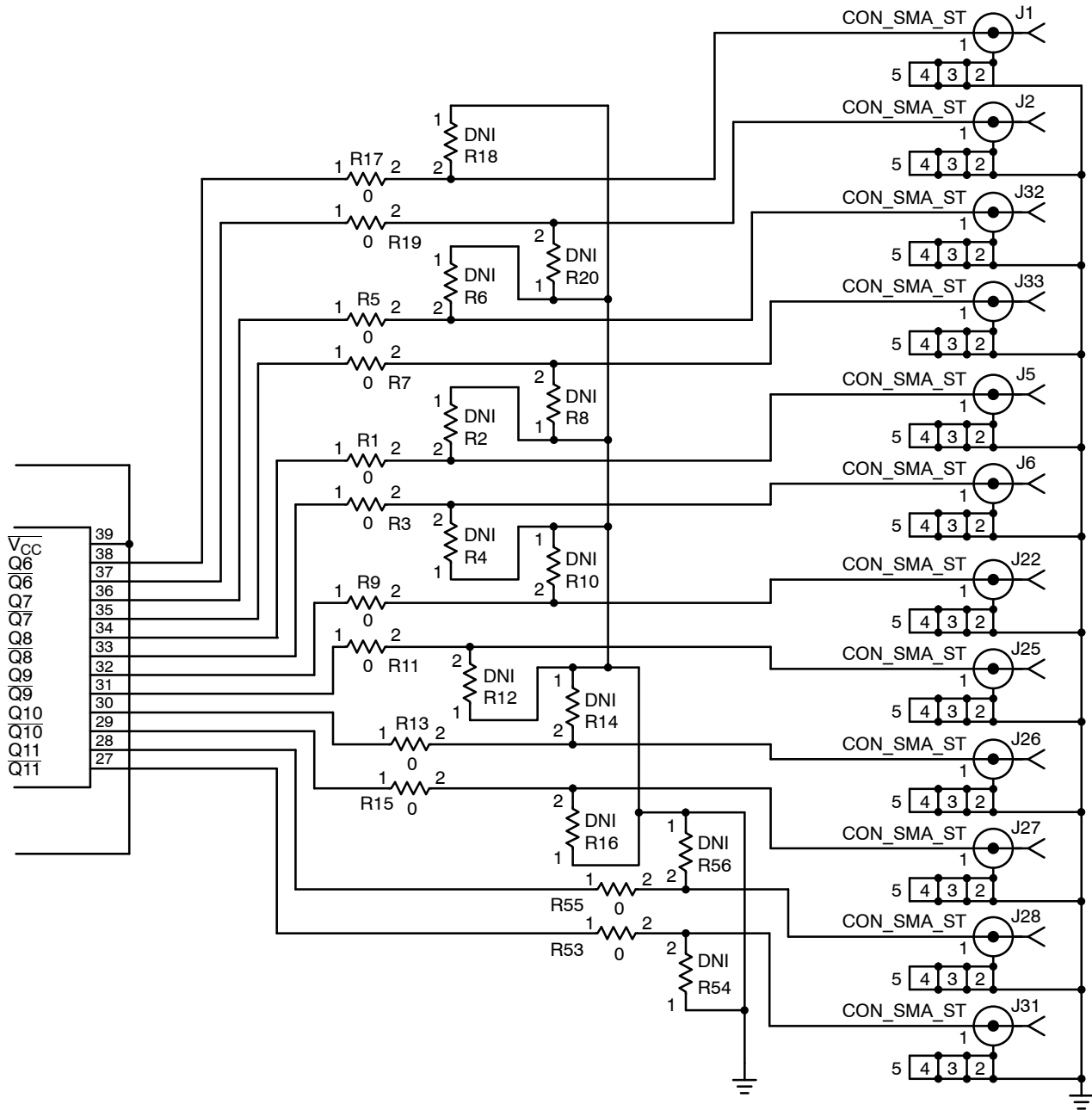
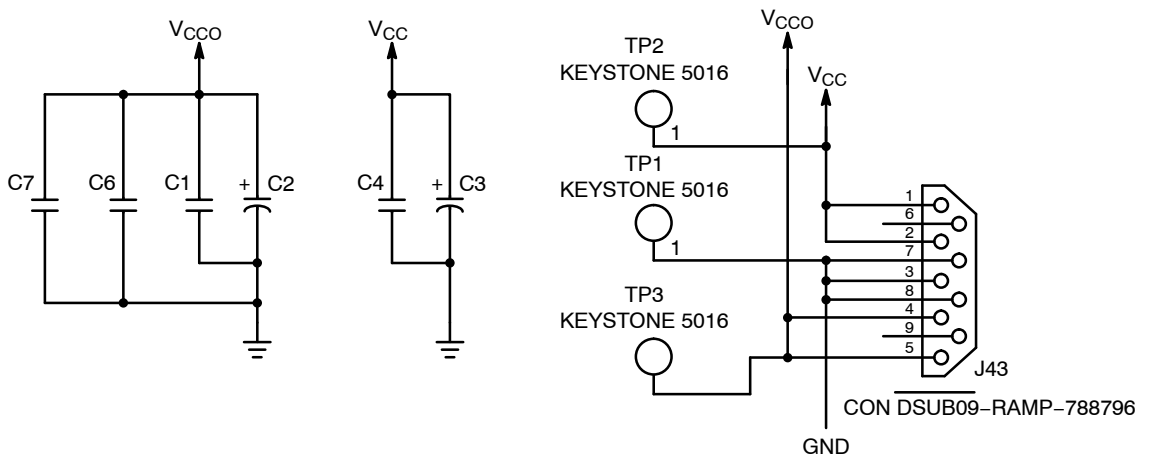
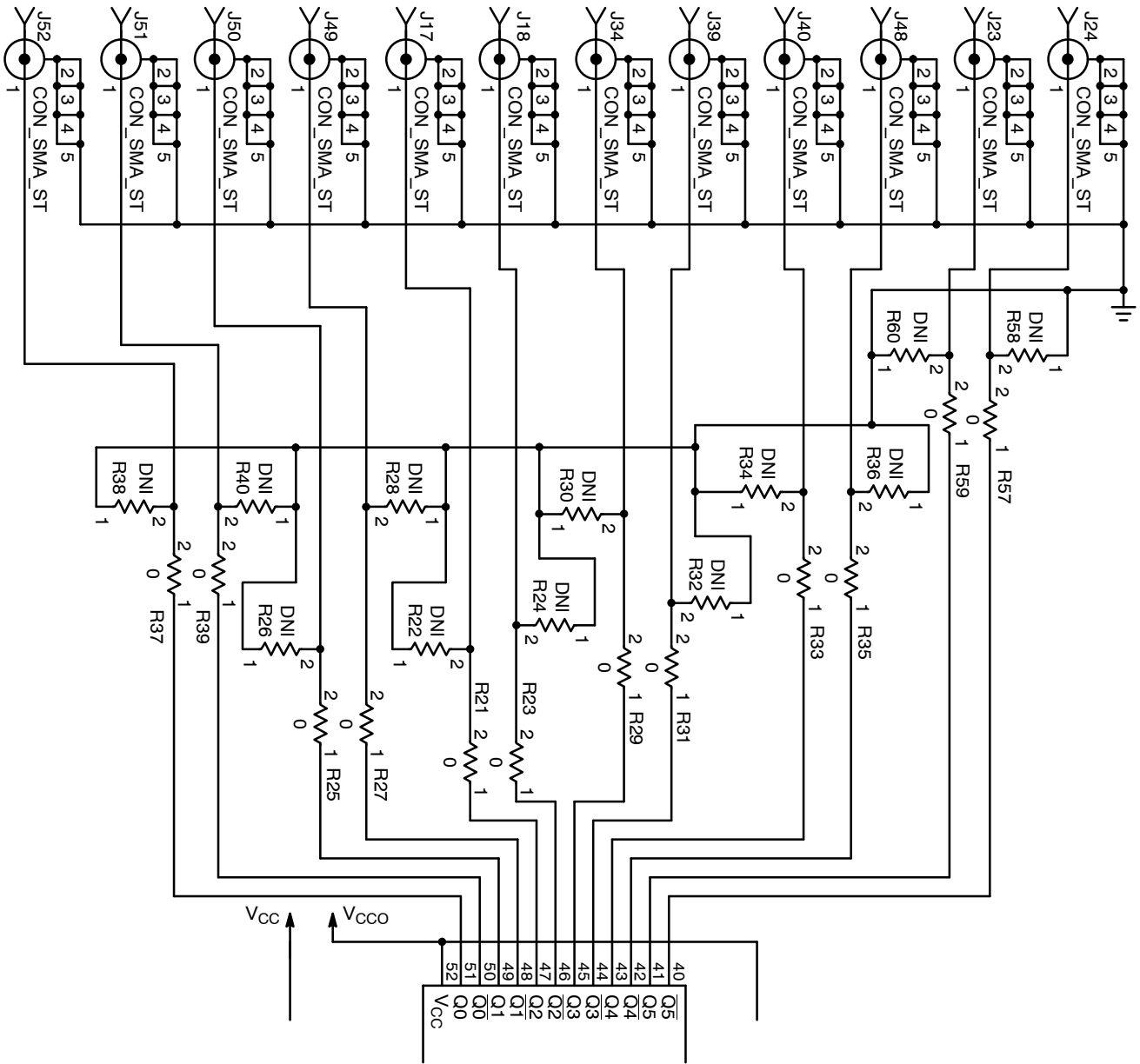

Figure 12. Pins 27 to 39

NB4N121KMNGEVB



NB4N121KMNGEVB

Appendix 3: Device I_{REF} Pin 1 Load Plot of R_{REF} vs. I_{REF} Current

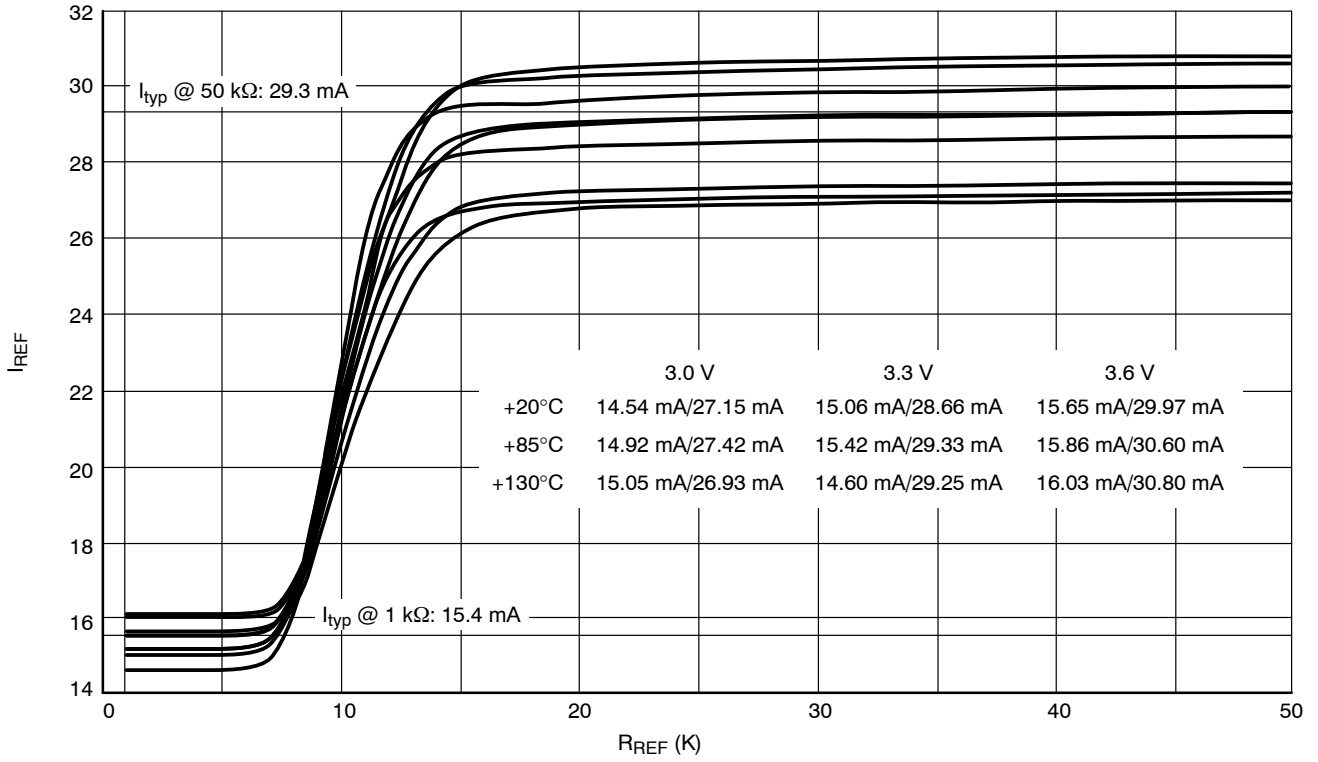

Figure 15. Device I_{REF} pin 1 Load Plot of R_{REF} vs. I_{REF} Current

NB4N121KMNGEVB

Appendix 4: Bill of Materials, Board Lamination Stackup, and Fabrication Notes

Bill of Materials Table

Top	Bot	Description	Value	Source	Source P/N	Reference Designators
0	5	Cap, Chip, 0.1 μ F, 0603, 50 V, 10% X7R	0.1 μ F			C1, C4, C5, C6, C7
0	2	Cap, Chip, 10 μ F, Tant "C", 25 V, 10%	10 μ F			C2, C3
1	0	ANTARES 52 QFN Socket			FP0052QN0805C	Alternative construction option: ANTARES Test Technology 3350 Scott Blvd., Bldg 58, Santa Clara, CA 95054, Phone: (408) 988-6800, www.antares-att.com
	4	2-56 Pem Nuts				DUT1
3		TP1, TP2, TP3				KEYSTONE 5016 (or similar)
46	0	Connector, SMA, Straight		Johnson	142-0701-201	J1, J2, J3, J4, J5, J6, J7, J8, J10, J11, J12, J13, J14J15, J16, J17, J18, J19, J20, J21, J22, J23, J24, J25, J26, J27, J28, J29, J30, J31, J32, J33, J34, J35, J36, J37, J38, J39, J40, J41, J42, J48, J49, J50, J51, J52
1		J43			CON DSUB09-RAMP-788796	J43 (Optional - Not Supplied)
0	42	Res, Chip, 0 Ω , 0603, 1/16 W, 5%	0			R1, R3, R5, R7, R9, R11, R13, R15, R17, R19, R21, R23, R25, R27, R29, R31, R33, R35, R37, R39, R41, R43, R45, R47, R49, R51, R53, R55, R57, R59, R61, R63, R65, R67, R69, R71, R73, R75, R77, R79, R81, R83
0	1	0-50 K POTENTIOMETER, TOP ADJUST	0-50 k Ω	BOURNS	3269W-1-503	R85

Board Lamination Stackup:

Dielectric is FR4 (interlayer between 1-2, 2-3, 3-4, 4-5, 5-6).

Layers #1 (Topside) and #6 (Bottomside) are signal path copper (trace width 0.014").

LAMINATION DIAGRAM					
Layer Number	Layer Name	Copper Thickness	Dielectric Thickness	Layer Material	Trace Width
1	TOP	1/2 OZ.			0.014
			0.008	See Note 1	
2	GND	1 OZ.			N/A
			0.005	See Note 1	
3	PWR1	1 OZ.			N/A
			Adjust	See Note 1	
4	PWR2	1 OZ.			N/A
			0.005	See Note 1	
5	GND	1 OZ.			N/A
			0.008	See Note 1	
6	BTN	1/2 OZ.			0.014

FINISHED PCB THICKNESS TO BE:	0.100 \pm 10%
-------------------------------	-----------------

NB4N121KMNGEVB

Board Fabrication Notes:

(Unless otherwise specified)

- 1. ARTWORK:**
Fabricate using ADC artwork No. AZ10035 Rev A.
Drill locations determined by ADC file
AZ10035NC.DRL
- 2. MATERIAL:**
High temp FR4 – 170°C Tg
- 3. BOARD THICKNESS:**
Refer to stacking diagram for finished board thickness.
- 4. TWIST AND WARP:**
Board twist shall not exceed 0.5% (0.005 in.) per linear inch.
- 5. PLATING:**
Copper thickness for internal and external layers is specified in the stacking diagram.
Finished PCB to be electrodeposited hard gold plate, type 1 (99.7% min gold), grade C (knoop hardness 130–200), class X, 3–10 micro inches thick, over entire board surface.
Selective plating is not required.

Hole Plating:

0.011 minimum barrel avg. / 0.009 absolute minimum. Absolute maximum to be determined by PCB vendor based on the required finished hole diameter. Hole diameters are after plating unless otherwise specified.

5.1 – Surface pads in this area to be free from any irregularities or defects that might hinder proper performance of the pad.

- 6. ANNULAR RING:**
Annular ring to be 0.005 minimum with top to bottom registration to be within 0.003.

- 7. SOLDERMASK:**
Apply soldermask, color: green, type: LP1, per artwork provided. If VIA plugs are required, plug pattern will be supplied with artwork.
- 8. SILKSCREEN:**
To be white, non-conductive ink per artwork. No ink is to be on plated thru hole or surface mount pads. Silkscreen lines and text width are to be 0.006 minimum.
- 9. SOLDERABILITY:**
Plated holes shall not be rough or irregular so as to prevent proper solder wicking.
- 10. DRILL CHART:**
Hole sizes specified are finished hole sizes, unless otherwise specified:
Standard plated hole tolerance is ± 0.003
Standard non-plated hole tolerance is ± 0.002
- 11. IMPEDANCE:**
Impedance controlled layers: 1, 6.
- 12. APPROVAL:**
100% continuity and isolation test required for each fabricated PCB. Final test data must be cross referenced to the IPC-D-356 file provided. A verification stamp is required on each PCB. A TDR report shall be provided for each impedance controlled layer at the time of shipment. Final acceptance shall be determined by these layers having a characteristic impedance of 50 ohms $\pm 10\%$. Vendor can make line width adjustments on impedance controlled conductor widths of 0.0005. All other artwork deviations must have prior approval from R&D ADC.

ON Semiconductor and **ON** are registered trademarks of Semiconductor Components Industries, LLC (SCILLC). SCILLC reserves the right to make changes without further notice to any products herein. SCILLC makes no warranty, representation or guarantee regarding the suitability of its products for any particular purpose, nor does SCILLC assume any liability arising out of the application or use of any product or circuit, and specifically disclaims any and all liability, including without limitation special, consequential or incidental damages. "Typical" parameters which may be provided in SCILLC data sheets and/or specifications can and do vary in different applications and actual performance may vary over time. All operating parameters, including "Typicals" must be validated for each customer application by customer's technical experts. SCILLC does not convey any license under its patent rights nor the rights of others. SCILLC products are not designed, intended, or authorized for use as components in systems intended for surgical implant into the body, or other applications intended to support or sustain life, or for any other application in which the failure of the SCILLC product could create a situation where personal injury or death may occur. Should Buyer purchase or use SCILLC products for any such unintended or unauthorized application, Buyer shall indemnify and hold SCILLC and its officers, employees, subsidiaries, affiliates, and distributors harmless against all claims, costs, damages, and expenses, and reasonable attorney fees arising out of, directly or indirectly, any claim of personal injury or death associated with such unintended or unauthorized use, even if such claim alleges that SCILLC was negligent regarding the design or manufacture of the part. SCILLC is an Equal Opportunity/Affirmative Action Employer. This literature is subject to all applicable copyright laws and is not for resale in any manner.

PUBLICATION ORDERING INFORMATION

LITERATURE FULFILLMENT:

Literature Distribution Center for ON Semiconductor
P.O. Box 5163, Denver, Colorado 80217 USA
Phone: 303-675-2175 or 800-344-3860 Toll Free USA/Canada
Fax: 303-675-2176 or 800-344-3867 Toll Free USA/Canada
Email: orderlit@onsemi.com

N. American Technical Support: 800-282-9855 Toll Free
USA/Canada
Europe, Middle East and Africa Technical Support:
Phone: 421 33 790 2910
Japan Customer Focus Center
Phone: 81-3-5817-1050

ON Semiconductor Website: www.onsemi.com

Order Literature: <http://www.onsemi.com/orderlit>

For additional information, please contact your local Sales Representative



Стандарт Электрон Связь

Мы молодая и активно развивающаяся компания в области поставок электронных компонентов. Мы поставляем электронные компоненты отечественного и импортного производства напрямую от производителей и с крупнейших складов мира.

Благодаря сотрудничеству с мировыми поставщиками мы осуществляем комплексные и плановые поставки широчайшего спектра электронных компонентов.

Собственная эффективная логистика и склад в обеспечивает надежную поставку продукции в точно указанные сроки по всей России.

Мы осуществляем техническую поддержку нашим клиентам и предпродажную проверку качества продукции. На все поставляемые продукты мы предоставляем гарантию .

Осуществляем поставки продукции под контролем ВП МО РФ на предприятия военно-промышленного комплекса России , а также работаем в рамках 275 ФЗ с открытием отдельных счетов в уполномоченном банке. Система менеджмента качества компании соответствует требованиям ГОСТ ISO 9001.

Минимальные сроки поставки, гибкие цены, неограниченный ассортимент и индивидуальный подход к клиентам являются основой для выстраивания долгосрочного и эффективного сотрудничества с предприятиями радиоэлектронной промышленности, предприятиями ВПК и научно-исследовательскими институтами России.

С нами вы становитесь еще успешнее!

Наши контакты:

Телефон: +7 812 627 14 35

Электронная почта: sales@st-electron.ru

Адрес: 198099, Санкт-Петербург,
Промышленная ул, дом № 19, литера Н,
помещение 100-Н Офис 331