

MAX32600MBED

ARM mbed Enabled Development Platform

General Description

The MAX32600MBED provides a convenient platform for evaluating the capabilities of the MAX32600 microcontroller. The MAX32600MBED also provides a complete, functional system ideal for developing and debugging applications.

The MAX32600MBED includes a MAX32600 Cortex[®]-M3 microcontroller, prototyping area with adjacent access to precision analog front end (AFE) connections, I/O access through Arduino[™]-compatible connectors, additional I/O access through 100mil x 100mil headers, USB interface, and other general-purpose I/O devices.

Kit Contents

- MAX32600MBED board with MAX32600 microcontroller
- USB Standard-A to Micro-B adapter cable (for connecting on-board HDK to a PC)
- Quick Start Guide

Benefits and Features

- On-Board ARM[®] mbed[™] Hardware Development Kit (HDK) Interface Provides Quick Connection to Toolchains
- Arduino-Compatible Connectors Provide Connectivity to Existing Component Boards
- Prototyping Area Allows Construction of User Circuits in Close Proximity to Precision AFE I/O
- General-Purpose Pushbutton Switches and LEDs Allow for On-Board Tactile and Visual Interaction
- Serial Peripheral Interface (SPI) and Inter-Integrated Circuit (I²C) Connectivity on a 2 x 6 Header Provide Connectivity to Existing Evaluation Modules
- USB Micro-B Connection to MAX32600 USB Device Controller Provides 12Mbps User Data Channel

Ordering Information appears at end of data sheet.

Block Diagram

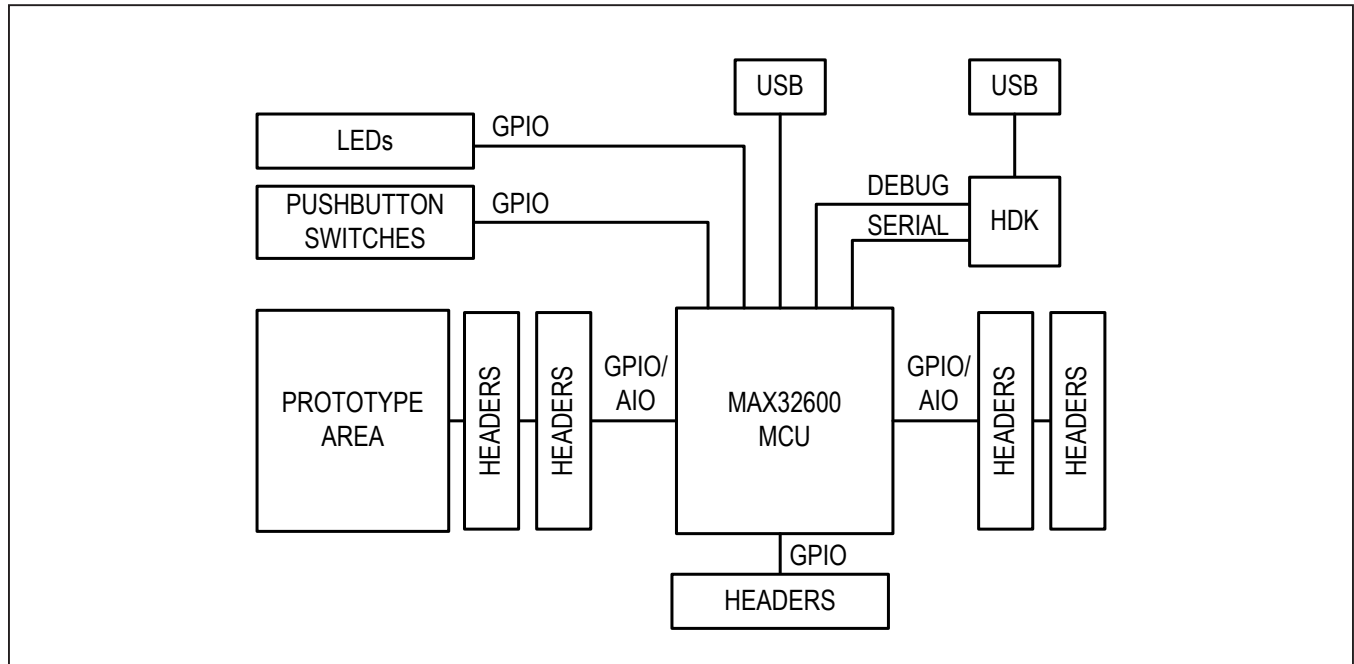

Cortex is a registered trademark of ARM Limited.

Arduino is a registered trademark of Arduino, LLC.

ARM is a registered trademark and registered service mark of ARM Limited.

mbed is a registered trademark of ARM Limited.



Detailed Description

The MAX32600MBED board is general purpose in nature. However, the ability to access the majority of I/O signals allow for easy evaluation of the MAX32600. This section describes each major function or component on the MAX32600MBED.

Board Power

The MAX32600MBED can be powered by either of the USB Micro-B connectors or an external source: VIN, V5.0, or V3.3.

HDK USB Supply

Power supplied from the HDK USB connector, CN2, shall be limited to 500mA. Only the HDK USB connector, CN2, powers the HDK circuitry. This supply is regulated to supply the HDK_V3.3 rail and is also connected to the V5.0 rail through a forward biased diode. From the V5.0 rail, it is regulated to supply V3.3.

MAX32600 USB Device Interface Supply

Power supplied from the MAX32600 USB device interface connector, CN1 is limited to 500mA. This supply is connected to the V5.0 rail through a forward biased diode. From the V5.0 rail, it is regulated to supply V3.3.

External Supply VIN

Power supplied from the VIN, J4 pin 8, is regulated to supply the V5.0 rail. The voltage input range for this input is 5V to 12V DC.

External Supplies V5.0 and V3.3

Power supplied by V5.0, J4 pin 5, is connected directly to the V5.0 rail. Likewise, power supplied by V3.3, J4 pin 4, is connected directly to the V3.3 rail.

Current Monitoring

Jumper JP4 provides a convenient current monitoring point for V3.3.

Pushbuttons

Two pushbuttons are available for application use: SW2 and SW3 are connected to port pins P6.4 and P6.5, respectively. Pushbuttons are normally open; therefore, provide a logic 0 when depressed. Firmware defines the action taken on switch closure.

Pushbutton SW4 provides a power-on reset function for the MAX32600 by asserting the RSTN input.

USB

The MAX32600 provides an integrated USB2.0 Full-speed interface (12Mbps). This interface is accessed through the USB Micro-B connector, CN1.

LEDs

Four LEDs are available for application use: D4 (yellow), D5 (red), D6 (blue) and D7 (green) are connected to MAX32620 GPIO pins P7.0, P7.1, P6.7, and P6.6, respectively. LED GPIOs should be configured as open-drain due to 3.3V LED source voltages. An LED illuminates when the appropriate GPIO pin is driven low.

Two power supply status LEDs, D9 and D10, are connected to supply rails V3.3 and V5.0, respectively.

Prototyping Area

An area for adding customer-specific circuitry is provided. This matrix is on 100mil spacing and is usable for solder or wire-wrap construction. Power and ground rails are conveniently located above and below this area.

Component List, Schematic, PCB

See the following links for component, schematic, and PCB information:

- [MAX32600MBED BOM](#)
- [MAX32600MBED Schematic](#)
- [MAX32600MBED PCB Layout](#)

Reference Material

- MAX32600 Data Sheet
- MAX32600 User Guide
- [MAX32600MBED mbed Platform Page](#)

Ordering Information

PART	TYPE
MAX32600MBED#	EV Kit

#DenotesRoHS compliant.

Revision History

REVISION NUMBER	REVISION DATE	DESCRIPTION	PAGES CHANGED
0	10/15	Initial release	—

For pricing, delivery, and ordering information, please contact Maxim Direct at 1-888-629-4642, or visit Maxim Integrated's website at www.maximintegrated.com.

Maxim Integrated cannot assume responsibility for use of any circuitry other than circuitry entirely embodied in a Maxim Integrated product. No circuit patent licenses are implied. Maxim Integrated reserves the right to change the circuitry and specifications without notice at any time. The parametric values (min and max limits) shown in the Electrical Characteristics table are guaranteed. Other parametric values quoted in this data sheet are provided for guidance.

Item #	Quantity	C1, C3, C16, C17, C41, C47	Designator	Notes	Footprint	Comment	Manufacturer Name	Part Number	Description	Vendor	Vendor Part Number
1	6	C1, C3, C16, C17, C41, C47	CAP0603-3D		0.1uF		Samsung Electro-Mechanics America, Inc	CL10B104K0BNNNC	CAP CER 0.1UF 16V 10% X7R 0603	Digikey	1276-1005-2-ND
2	1	C2	CAP0603-3D		30pF		Samsung Electro-Mechanics America, Inc	CL10C300B8NNNC	CAP CER 30PF 50V 5% NPO 0603	Digikey	1276-1021-1-ND
3	4	C4, C5, C18, C19	CAP0603-3D		27pF		Samsung Electro-Mechanics America, Inc	CL10C270B8NNNC	CAP CER 27PF 50V 5% NPO 0603	Digikey	1276-1086-2-ND
4	11	C6, C11, C22, C23, C24, C25, C29, C30, C34, C36, C37	CAP0402-3D		1.0uF		Samsung Electro-Mechanics America, Inc	CL05A105K0SNNNC	CAP CER 1UF 6.3V 10% X5R 0402	Digikey	1276-1010-2-ND
5	7	C7, C9, C10, C13, C14, C20, C31	CAP0402-3D		0.1uF		Samsung Electro-Mechanics America, Inc	CL05A104K0SNNNC	CAP CER 0.1UF 6.3V 10% X5R 0402	Digikey	1276-1442-2-ND
6	1	C8	CAP0402-3D		0.01uF		Samsung Electro-Mechanics America, Inc	CL10B103K8BNCNC	CAP CER 10000PF 16V 10% X7R 0402	Digikey	1276-1051-2-ND
7	3	C12, C43, C48	CAP0805-3D		10uF		TDK Corporation	C2012X5R1A106K125AB	CAP CER 10UF 10V 10% X5R 0805	Digikey	445-7660-1-ND
8	1	C15	CAP0603-3D		330pF		Murata Electronics North America	GRM1885C1H31JA01D	CAP CER 330PF 50V 5% NPO 0603	Digikey	490-1439-1-ND
9	7	C21, C26, C27, C28, C32, C33, C35	CAP0603-3D		4.7uF		Samsung Electro-Mechanics America, Inc	CL10B475K0B8NQCNC	CAP CER 4.7UF 6.3V 10% X7R 0603	Digikey	1276-2087-2-ND
10	2	C38, C44	CAP0805-3D		22uF		TDK Corporation	C2012X5R1C226M085AC	CAP CER 22UF 16V 20% X5R 0805	Digikey	445-14374-1-ND
11	2	C39, C45	CAP0603-3D		0.01uF		Samsung Electro-Mechanics America, Inc	CL10B103K8BNCNC	CAP CER 10000PF 50V 10% X7R 0603	Digikey	1276-1921-2-ND
12	2	C40, C46	CAP0805-3D		2.2uF		Murata Electronics North America	GRM21BF51C225Z01L	CAP CER 2.2UF 16V Y5V 0805	Digikey	490-1741-1-ND
13	1	C42	CAP0805-3D		4.7uF		Samsung Electro-Mechanics America, Inc	CL12A475KPFNNNE	CAP CER 4.7UF 10V 10% X5R 0805	Digikey	1276-1259-2-ND
14	2	CN1, CN2	USBMICROB-3D		Micro USB		FCI	110103594-0001LF	USB MICRO B TOP MOUNT	Digikey	609-4050-1-ND
15	4	D1, D4, D9, D10	0603LED-3DRED		RED		Lite-On Inc	LTST-C193KRKT-5A	LED RED RECT CLEAR 0603	Digikey	160-1830-1-ND
16	2	D2, D5	0603LED-3DBLUE		BLUE		OSRAM Opto Semiconductors Inc	LB Q39G-L2N2-35-1	LED CHIPLED BLUE 470NM 0603 SMD	Digikey	475-2816-1-ND
17	2	D3, D6	0603LED-3DGREEN		GREEN		Dialight	598-8081-107F	LED INGAN GREEN CLEAR 0603 SMD	Digikey	350-2036-1-ND
18	1	D7	0603LED-3DORANGE		YELLOW		Wurth Electronics Inc	150060Y575000	WL-SMCW SMD CHIP LED WATERCLEAR 120mcd	Digikey	732-4981-1-ND
19	2	DB, D11	DIODE2223-3D		ES1B-E3/SAT		Vishay Semiconductor Diodes Division	ES1B-E3/SAT	DIODE UFASOT 1A D0214AC	Digikey	ES1B-E3/SATGIC1-ND
20	2	F81, F82	0805FB-3D		BLM21PG2215N1D		Murata Electronics North America	BLM21PG2215N1D	FERRITE CHIP 220 OHM 0805	Digikey	490-1054-1-ND
21	1	J3	SIP10		CON10		Sullins Connector Solutions	PPPC1011FBN-RC	CONN HEADER FEMALE 10POS. 1" GOLD	Digikey	5740-153-ND
22	2	J4, J6	SIP8		CON8		Sullins Connector Solutions	PPPC0811FBN-RC	CONN HEADER FEMALE 8POS. 1" GOLD	Digikey	57041-ND
23	1	J5	SIP6		CON6		Sullins Connector Solutions	PPPC0611FBN-RC	CONN HEADER FEMALE 6POS. 1" GOLD	Digikey	57039-ND
24	1	J11	DH10X2		PORT 2 & 3		FCI	68602-220HLF	CONN HEADER 20POS. 100 STR 15AU	Digikey	609-3375-ND
25	2	J7	SIP2	DNI							
26	3	J13, J15, J16	DIH8X2		PORTS, PORT 1 & 4		FCI	68602-216HLF	CONN HEADER 16POS. 100 STR 15AU	Mouser	"609-3374-ND" "649-68602-216HLF"
27	1	J17	DIH6X2	DNI	PORT0		Sullins Connector Solutions	PPPC062LJBN-RC	CONN FEMALE 12POSDDL 1" R/A GOLD	Digikey	55559-ND
28	1	J18	DIH3x2		PORT6		FCI	68602-206HLF	CONN HEADER 6POS. 100 STR 15AU	Digikey	609-3370-ND
29	2	JP3, JP4	SIP2	Cut to 2 pin lengths	JUMPER		Sullins Connector Solutions	PBC36SAAN	CONN HEADER 100 SINGL STR 36POS	Digikey	51011E-36-ND
30	1	Q1	16001-3D		2N7002		NXP Semiconductors	2N7002BK_215	MOSFET N-CH 60V 350MA SOT23	Digikey	568-5981-1-ND
31	1	Q2	SOT523-3D		MMBT3904		Diodes Incorporated	MMBT3904T-7-F	TRANS NPN 40V 0.2A SOT523	Digikey	MMBT3904T-FDICT-ND
32	1	R1	0603-3D		20k		Rohm Semiconductor	MCR03ERT2002	RES SMD 20K OHM 1% 1/10W 0603	Digikey	RHM20.0KCFTR-ND
33	2	R2, R4	0603-3D		500k		Yageo	CRCW0603499KFKEA	RES SMD 499K OHM 1% 1/10W 0603	Digikey	541-499KHTR-ND
34	5	R3, R12, R21, R26, R27	0603-3D		1K		Yageo	RC0603FR-071KL	RES SMD 1K OHM 1% 1/10W 0603	Digikey	311-1.00KHTR-ND
35	2	R5, R14	0603-3D		1.5K		Panasonic Electronic Components	ERI-3EK1F1501V	RES SMD 1.5K OHM 1% 1/10W 0603	Digikey	P1.50KHTR-ND
36	8	R6, R9, R10, R16, R17, R19, R23, R24	0603-3D		10k		Panasonic Electronic Components	ERI-3EK1002V	RES SMD 10K OHM 1% 1/10W 0603	Digikey	P10.0KHTR-ND
37	1	R7	0603-3D		68 ohm		Samsung Electro-Mechanics America, Inc	RC1608F680CS	RES SMD 68 OHM 1% 1/10W 0603	Digikey	1276-4550-1-ND
38	3	R8, R30, R31	0603-3D		100 ohm		Samsung Electro-Mechanics America, Inc	RC1608F101CS	RES SMD 100 OHM 1% 1/10W 0603	Digikey	1276-3482-2-ND
39	1	R11	0603-3D		4.7k		Rohm Semiconductor	MCR03ERT4701	RES SMD 4.7K OHM 1% 1/10W 0603	Digikey	RHM4.70KCFTR-ND
40	1	R18	0603-3D		4.02k		Yageo	RT0603DRD074K02L	RES SMD 4.02K OHM 0.5% 1/10W	Digikey	311-4.02KCT-ND
41	1	R25	0402-3D	DNI	0N1		N/A	N/A		N/A	N/A
42	1	R13, R15, R20, R22, R25	0603-3D	DNI	0N1		N/A	N/A		N/A	N/A
43	2	R28, R29	0603-3D		10 ohm		Panasonic Electronic Components	ERI-3EK10RDV	RES SMD 10 OHM 1% 1/10W 0603	Digikey	P10.0HTR-ND
44	2	R33, R35	0603-3D		0 Ohm		Panasonic Electronic Components	ERI-3GEY0RDV	RES SMD 0.0 OHM JUMPER 1/10W	Digikey	P0.0GTR-ND
45	2	RT1, RT2	1206POLYFUSE-3D		PTC Fuse		Bourns Inc.	MF-NSMF012-2	PTC RESETTABLE 12A 30V 1206	Digikey	MF-NSMF012-2CT-ND
46	1	SW1	SIP2	DNI			N/A	N/A		N/A	N/A
47	3	SW2, SW3, SW4	RESET11-3D		PUSH		C&K Components	KSR2212GLFS	SWITCH TACTILE SPST-NO 0.05A 32V	Digikey	401-1703-1-ND
48	1	U1	BGA121 8x8mm 0.65p		MAX32550		Maxim Integrated	MAX32550	Secure Cortex-M3 Flash Microcontroller	Digikey	N/A
49	1	U2	SOT23-5-3D		NC7S232		Fairchild Semiconductor	NC7S232M5X	IC GATE OR 1CH 2-INP SOT-23-5	Digikey	NC7S232M5XCT-ND
50	1	U3	VFSOP8		SN74LVC3G34		Texas Instruments	SN74LVC3G34DCLR	IC BUFFER TRPL NON-INV US8	Digikey	296-13286-1-ND
51	1	U4	TSSOP20		SN74LVC541A		Texas Instruments	SN74LVC541ADBR	IC BUFF/DVR TRI-ST 8BIT 20SSOP	Digikey	296-8518-1-ND
52	1	U5	WASPBGA192		MAX32600		Maxim Integrated	MAX32600	Secure Sensor Measurement Microcontroller	N/A	N/A
53	1	U6	TDFN8 3mm 65T		MAX16910CATAB+		Maxim Integrated	MAX16910CATAB/+	Linear Regulator 3V/5V/ADJ 200mA	N/A	N/A
54	2	U7, U9	SOT23-5-3D		MAX8887EK33+		Maxim Integrated	MAX8887EK33+	LDO 300mA Linear Regulator 3.3v version	N/A	N/A
55	2	U8, U10	sot23-6-3D		MAX3207EAUT+		Maxim Integrated	MAX3207EAUT+	Dual High-Speed Differential ESD-Protection IC	N/A	N/A
56	2	X1, X3	CRYSTAL-ABS07		32.768KHZ		Abracon LLC	ABS07-32.768KHZ-6-T	CRYSTAL 32.768KHZ 6-0PF SMD	Digikey	535-11898-1-ND
57	1	X2	CRYSTAL-ABM3X		12 MHz		Abracon LLC	ABM3B-12.000MHZ-82-T	CRYSTAL 12MHZ 18PF SMD	Digikey	535-9116-1-ND
58	1	X4			24MHz		Abracon LLC	ABM7-24.000MHZ-D2Y-T	CRYSTAL 24MHZ 18PF SMD	Digikey	535-9845-1-ND

BUFFERS

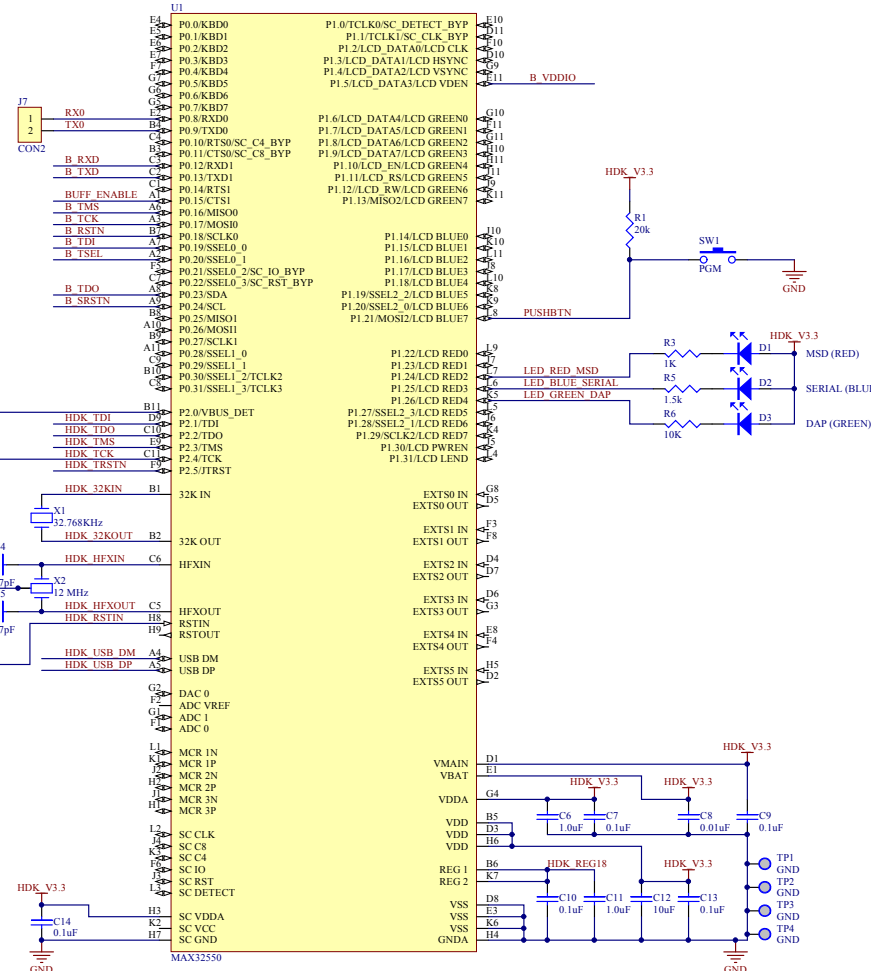
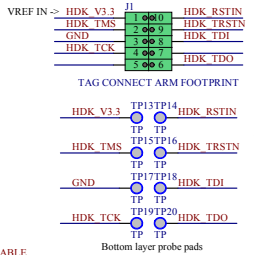
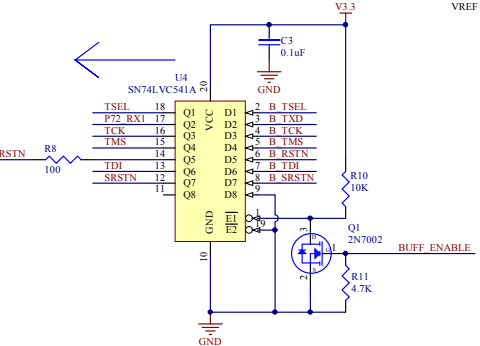
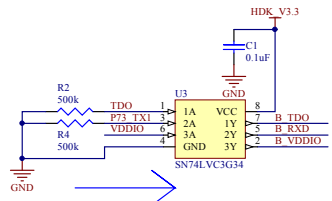

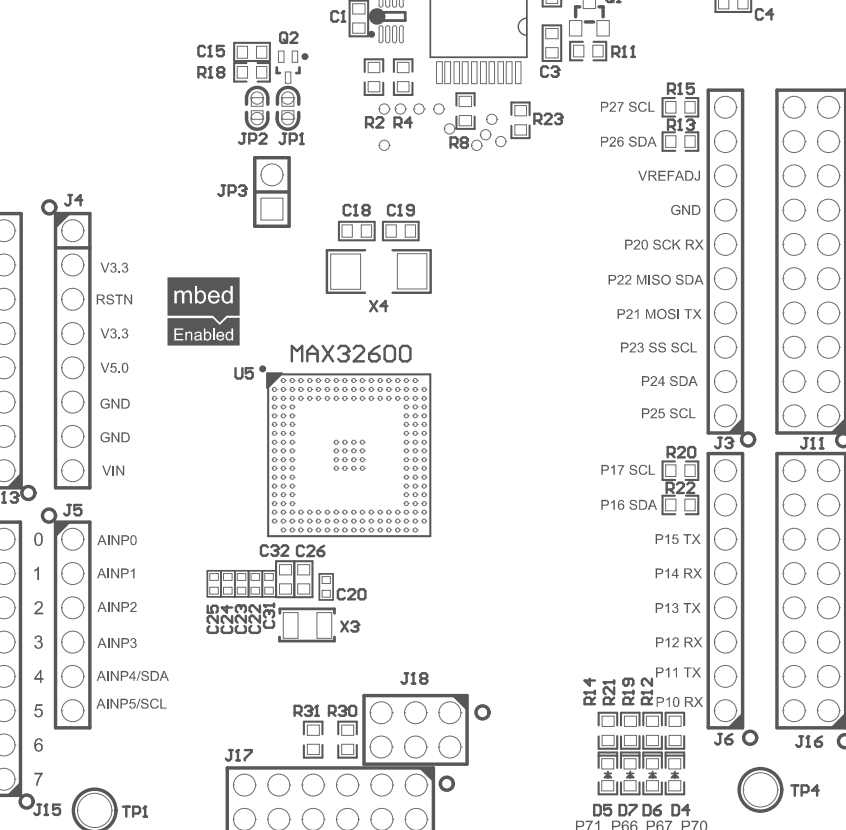
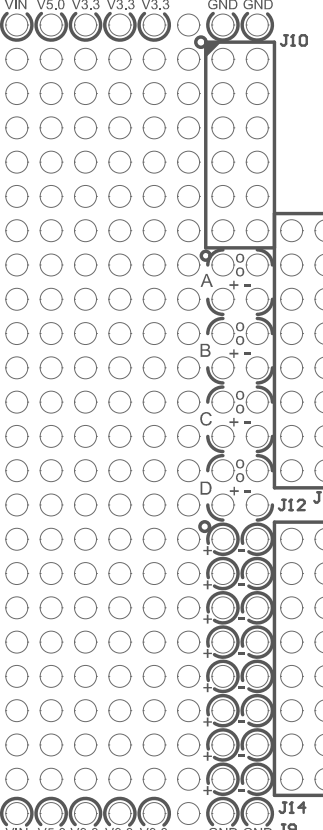
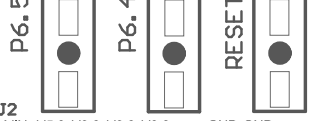
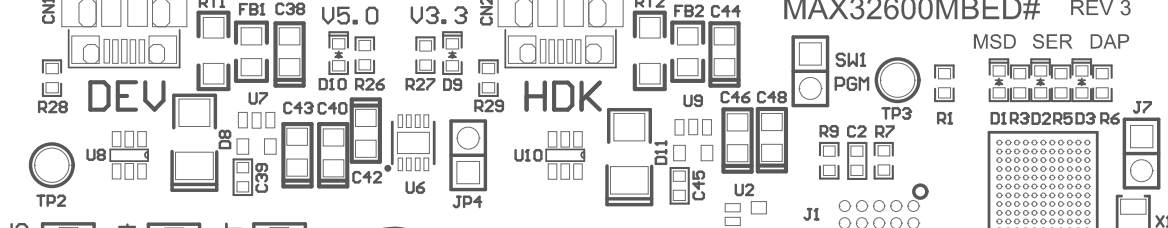

- V3.3
- RSTN
- V3.3
- V5.0
- GND
- GND
- VIN

- 0 AINP0
- 1 AINP1
- 2 AINP2
- 3 AINP3
- 4 AINP4/SDA
- 5 AINP5/SCL
- 6
- 7

- P27 SCL R15
- P26 SDA R13
- VREFADJ
- GND
- P20 SCK RX
- P22 MISO SDA
- P21 MOSI TX
- P23 SS SCL
- P24 SDA
- P25 SCL
- P17 SCL R20
- P16 SDA R22
- P15 TX
- P14 RX
- P13 TX
- P12 RX
- P11 TX
- P10 RX
- D5 D7 D6 D4
- P71 P66 P67 P70

C14
C13 C8
C9
C10
C7
C6
C12
C11

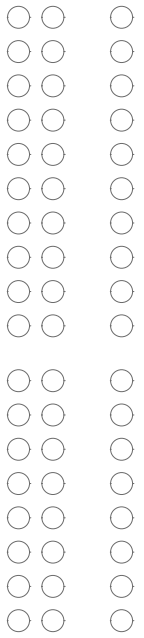
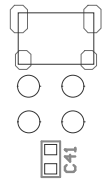
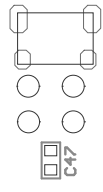
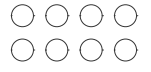

C27 R25
C33 C29
C34 C30
C21 C35
C28
C36 C37

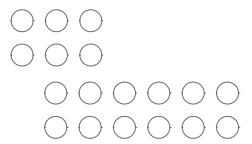

SDA R34
SCL R32

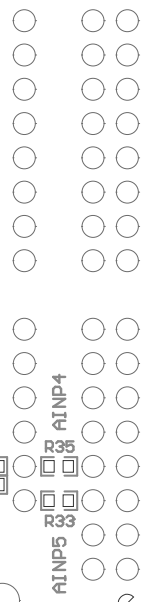

AINP4
AINP3
AINP4
AINP5

R24
R16 C16
R17 C17

GND GND V3.3 V3.3 V3.3 V5.0 VIN

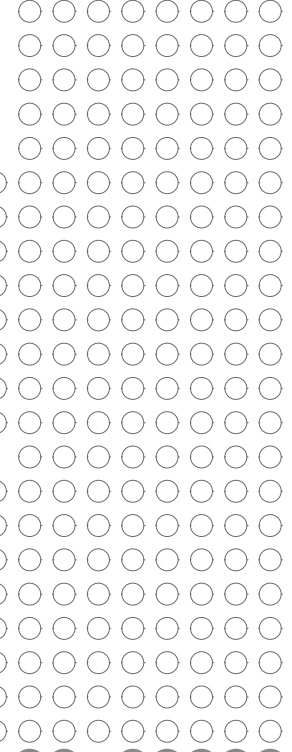

GND GND V3.3 V3.3 V3.3 V5.0 VIN



Стандарт Электрон Связь

Мы молодая и активно развивающаяся компания в области поставок электронных компонентов. Мы поставляем электронные компоненты отечественного и импортного производства напрямую от производителей и с крупнейших складов мира.

Благодаря сотрудничеству с мировыми поставщиками мы осуществляем комплексные и плановые поставки широчайшего спектра электронных компонентов.

Собственная эффективная логистика и склад в обеспечивает надежную поставку продукции в точно указанные сроки по всей России.

Мы осуществляем техническую поддержку нашим клиентам и предпродажную проверку качества продукции. На все поставляемые продукты мы предоставляем гарантию .

Осуществляем поставки продукции под контролем ВП МО РФ на предприятия военно-промышленного комплекса России , а также работаем в рамках 275 ФЗ с открытием отдельных счетов в уполномоченном банке. Система менеджмента качества компании соответствует требованиям ГОСТ ISO 9001.

Минимальные сроки поставки, гибкие цены, неограниченный ассортимент и индивидуальный подход к клиентам являются основой для выстраивания долгосрочного и эффективного сотрудничества с предприятиями радиоэлектронной промышленности, предприятиями ВПК и научно-исследовательскими институтами России.

С нами вы становитесь еще успешнее!

Наши контакты:

Телефон: +7 812 627 14 35

Электронная почта: sales@st-electron.ru

Адрес: 198099, Санкт-Петербург,
Промышленная ул, дом № 19, литера Н,
помещение 100-Н Офис 331