



Autonomous 8-Angle Tip-Over Sensor with High Vibration Immunity

MXD6240/6241AU

FEATURES

- 8 Pin-programmable angle thresholds
- Single-wire digital output
- Fully autonomous- no uC required
- Built-in self-test functionality
- Small, 6-pin 3 x 3mm LCC package
- Operates from 2.7V to 5.5V Supply
- No sensor resonance
- Vibration filter: tolerates 20 g p-p @ 50Hz vibration with < 1° incremental angle error
- High reliability automotive process
- RoHS compliant
- Operates from -40 C to +125 C

APPLICATIONS :

Motorcycle Fall-Down Detection
Off-Road Vehicles
Jetski, watercraft
Other Tip-Over Detection (Space heaters, Irons, etc)

DESCRIPTION:

The MXD6240/6241AU is an inclination sensor with 8 built-in, pin-programmable angle thresholds. If the device orientation with respect to vertical exceeds the programmed threshold angle, the digital output changes state to alert the system to a tip-over or fall-down event. An internal anti-vibration filter provides >45dB attenuation above 25Hz, and >60dB attenuation above 50Hz.

The MXD6240/6241AU is designed to run autonomously, making it ideal for systems where there is no uC available. One of eight threshold angles (40, 42.5, 45, 50, 55, 60, 65, and 70 degrees) is selected by connecting each of three programming pins to Vdd or Gnd. The threshold accuracy is guaranteed to meet +/-5 degrees (max) over a temperature range of -20C to +80C (Operation is guaranteed over -40C to +125C).

A built-in self-test function can detect a fault in the internal sensor, and if triggered will cause the output to go to a high impedance state.

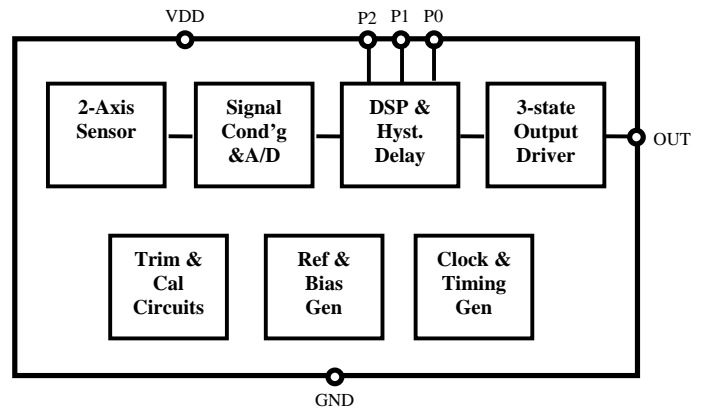

Figure 1. FUNCTIONAL BLOCK DIAGRAM

The MXD6240/6241AU uses MEMSIC's proprietary thermal accelerometer technology. Because the sensing element uses heated gas molecules instead of a mechanical beam structure, the device is extremely robust and reliable, with 50,000g shock tolerance, no possibility of "stiction", virtually no mechanical resonance, and extremely high accuracy over temperature. This makes the device extremely well suited to harsh or high vibration environments, where other sensors can exhibit false readings due to resonance or other errors.

The MXD6240AU output is a logic low under normal operation, and logic high during tip-over; the MXD6241AU uses the opposite output polarity (normally high, low during tip-over). A high-Z output state signifies an internal self-test failure.

Both devices operate from a single 2.7V to 5.5V supply, and are packaged in a small 6-pin, 3x3x1 mm LCC package.

Information furnished by MEMSIC is believed to be accurate and reliable. However, no responsibility is assumed by MEMSIC for its use, or for any infringements of patents or other rights of third parties which may result from its use. No license is granted by implication or otherwise under any patent or patent rights of MEMSIC.

©MEMSIC, Inc.
One Technology Drive, Suite 325, Andover, MA 01810, USA
Tel: +1 978 738 0900 Fax: +1 978 738 0196
www.memsic.com

SENSOR CHARACTERISTICS:

(TA=25C, V_{DD}= 5V, unless otherwise specified. Typical values are specified at 25C)

Parameter	Conditions	Min	Typ	Max	Units
Threshold Angles	Pin-Programmable via P2, P1, P0		40, 42.5, 45, 50, 55, 60, 65, 70		Deg
Threshold Accuracy (Note 1)	TA = -20C to +80C		±2	±5	Deg
Threshold Error due to Vibration (Note 2)	20g p-p @ f ≥ 25Hz		±3		Deg
	20g p-p @ f ≥ 50Hz		±0.5		
Sensor Bandwidth	(Note 3)		11		Hz
Resonance	(Note 4)	Undetectable			Hz
Shock Tolerance			50,000		g
Off-Axis Tilt Range	(For rated accuracy)		±15		Deg
LOW-G Lockout Threshold	(Note 5)		0.375		g

Note 1: Guaranteed by design and characterization, using ±4σ limits.

Note 2: This is the incremental threshold error due to the vibration signal, applied parallel to the y axis

Note 3: The sensor has an inherent low pass filter characteristic, which is very effective in attenuating out of band vibration.

Note 4: The thermal accelerometer sensors use heated gas molecules, and have no measurable resonance

Note 5: The LOW-G Lockout feature disables tip-over detection if the magnitude of both X and Y acceleration vectors fall below 0.375g (as in the case of a free-fall or large off-axis tilt condition). See also "Fault Detection".

ELECTRICAL SPECIFICATIONS:

(TA=25C, V_{DD}= 5V, unless otherwise specified. Typical values are specified at 25C)

Parameter	Conditions	Min	Typ	Max	Units
Supply Voltage		2.7		5.5	V
Supply Current			0.8	3	mA
Operating Temperature		-40		125	°C
Output Update Rate (ODR)	(Note 6)	2.7	3	3.3	Hz
Power On Time	VDD rising edge to angle detection active		300	500	ms
Power On Reset Threshold		0.8	1.2	1.6	V
VDD Rise Time	(Note 7)			8	ms

Note 6: This is the rate at which the logic state of the OUTPUT pin is updated. The output will typically change state within 1 – 2 ODR cycles of a change in tip-over orientation. The above applies for V_{DD} = 5V. At V_{DD} = 2.7V, the ODR slows by ~15%.

Note 7: Maximum allowable power supply rise time from 0.25V to 2.7V (minimum). Slower VDD rise time may cause erroneous data retrieval from OTP memory at power-up.

DIGITAL PARAMETERS

(TA=25C, V_{DD}= 5V, unless otherwise specified. Typical values are specified at 25C)

Parameter	Conditions	Min	Typ	Max	Units
Logic Input Low	P2, P1, P0 Inputs		0	0.3*V _{DD}	V
Logic Input High	P2, P1, P0 Inputs	0.7*V _{DD}	V _{DD}		V
Logic Output Low	Sinking 0.5mA (Note 8)			0.1*V _{DD}	V
Logic Output High	Sourcing 0.5mA (Note 8)	0.9*V _{DD}			
Logic Output High-Z	After sensor fault is detected		1		Mohm

Note 8: The output driver is capable of sourcing and sinking much higher currents, but it is recommended to keep the load current below 0.5mA to avoid thermal gradients which may affect the angle threshold accuracy.

ABSOLUTE MAXIMUM RATINGS*

Supply Voltage (V_{DD})-0.5 to +7V
 Storage Temperature-40°C to +150°C

*Stresses above those listed under Absolute Maximum Ratings may cause permanent damage to the device. This is a stress rating only; the functional operation of the device at these or any other conditions above those indicated in the operational sections of this specification is not implied. Exposure to absolute maximum rating conditions for extended periods may affect the device's reliability.

PIN DESCRIPTION: LCC-6 Package

Pin	Name	Description	I/O
1	OUT	Digital Output. This pin will be low under normal operation, and will transition to high to alert to a tip-over event (MXD6240). The MXD6241 uses the opposite convention (high under normal operation, low to signify tip-over). A high impedance state reflects a fault condition in the sensor.	O
2	P2	Programming pin. Sets the threshold angle (see table).	I
3	VDD	Positive power supply. Connect to 2.7V to 5.5V. Bypass this to ground using a tbd capacitor.	P
4	P1	Programming pin. Sets the threshold angle (see table).	I
5	P0	Programming pin, sets the threshold angle (see table).	I
6	GND	Connect to power supply ground.	P

THRESHOLD PROGRAMMING GUIDE

P2	P1	P0	Threshold Angle Θ
0	0	0	40 degrees
0	0	1	45 degrees
0	1	0	50 degrees
0	1	1	55 degrees
1	0	0	60 degrees
1	0	1	65 degrees
1	1	0	70 degrees
1	1	1	42.5 degrees

MOUNTING ORIENTATION

(Threshold Angle = Θ below)
 (Off-Axis Tilt = Φ below)

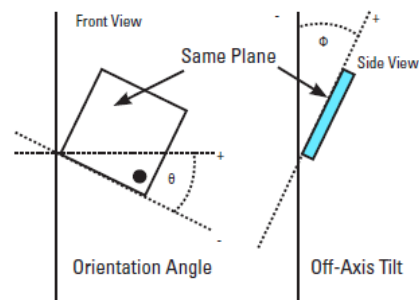

Note the package must be oriented vertically as shown in the figure above, so that when the detection angle is zero, the edge of the package with pins 1 and 6 is on the bottom edge and parallel to the earth.

Off-axis tilt is the angle of the x-y plane of the device from vertical (See figure above). As off-axis tilt increases from 0 to 90 degrees, the magnitude of the acceleration vector in the x-y plane decreases. If the acceleration signal is too small, an accurate determination of orientation cannot be made. For orientation measurements to be valid, the off-axis tilt must be less than the off-axis tilt threshold. Angle accuracy is degraded when off-axis tilt angle exceeds 15 degrees. If the off axis tilt exceeds 60 degrees, the angle detection function is disabled.

INTERNAL FAULT DETECTION

The MXD6240/6241 has a variety of internal fault detection circuit features.

On power up, the internal circuitry checks for the following condition:

- (a) Valid non-volatile memory contents. Within 10ms of VDD rising edge, a CRC algorithm checks if any of the bits have changed from their factory programmed values. On power up, the OUT pin is high-Z. A transition to a valid logic state signifies the successful completion of the CRC self-check. If this test fails, the output will remain in a high impedance state until the power supply is removed and re-applied, at which time the self-test is repeated.

In addition to the above test done at power up, the following monitoring is performed on a continuous basis:

- (b) If at any time either the X or Y output exceeds 2g continuously for more than approximately 4 seconds (see Note 9), the output is set to a high impedance state, and remains there for as long as the condition persists
- (c) If at any time both the X and the Y outputs fall below 0.375g (which is an indication of either a free fall event, excessive off-axis tilt, or a leak in the gas cavity), the angle-detection function is disabled immediately, to prevent false triggering of the angle comparator. If this condition persists for more than approximately 4 seconds (See Note 9), the output will go to a high impedance state for as long as the condition persists.

In each of the above cases (b) and (c), the fault detection circuitry takes precedence over the tip-over detection circuitry (the output will remain in the high impedance state regardless of the angle detected, for as long as the fault condition persists).

Note 9: The actual delay time for the triggering of the fault condition (high impedance output) can vary from a minimum of 2.3 sec to a maximum of 5.7 seconds, depending on the state of the internal signal processing when the fault condition is first detected. Note this is not to be confused with the Tip-Over delay, which is based on the 3Hz Output Data Rate (ODR) of the device (thus tip-over would be reflected on the OUT pin within 1-2 clock cycles (330 – 670ms)).

RESPONSE TO VIBRATION

The MXD6240/6241 is unique in its vibration characteristics, due both to its sensor structure, and its signal processing features.

The MXD6241/6241 uses MEMSIC's proprietary thermal MEMS acceleration sensor, which uses heated gas molecules in a sealed cavity. This technology offers two distinct benefits: (a) The sensor has no detectable resonance, and (b) The sensor has an inherent low-pass frequency response, which provides very effective filtering of unwanted vibration signals prior to the electronic signal path. Additional filtering is provided in the signal processing circuitry, which enables the device to tolerate very high levels of out-of-band vibration with negligible effect on angle detection accuracy.

Figure A is a plot showing the worst case threshold error caused by a 20g p-p vibration signal, swept from 10 Hz to 1 kHz. The angle error will scale linearly with the vibration amplitude at any given frequency.

Figure A: Threshold Angle Error vs. Vibration Frequency (simulated), 20g p-p Vibration Swept from 10Hz to 1kHz

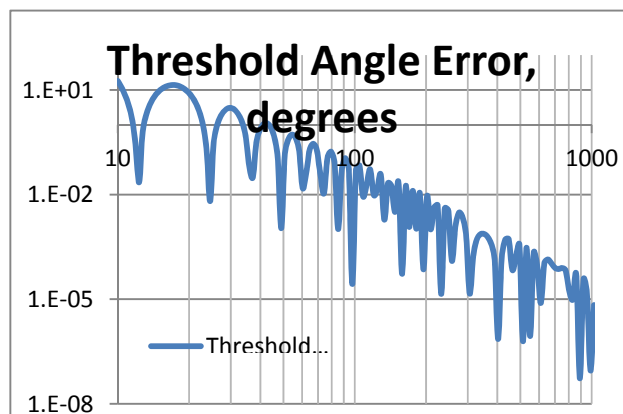

MEMSIC has some flexibility in tuning the frequency response and full scale range of the solution. For applications with unique vibration environments, contact the factory for more information.

CIRCUIT SCHEMATICS

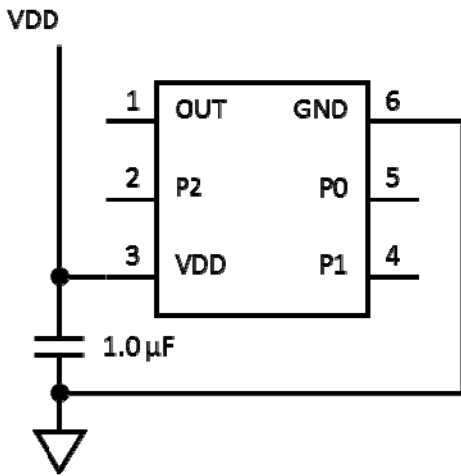

LANDING PATTERN (Unit: mm)

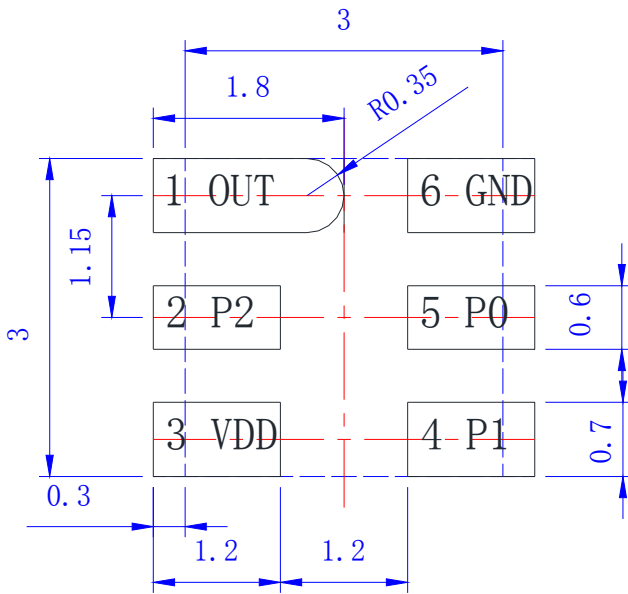

REFLOW PROFILE

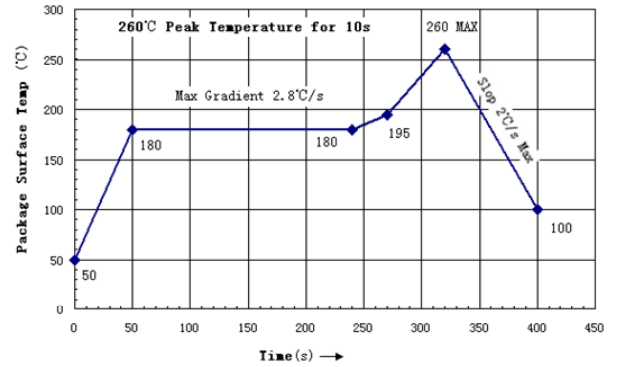

Notes:

- ◆ Reflow is limited to two cycles.
- ◆ If a second reflow cycle is implemented, it should be applied only after device has cooled down to 25°C (room temperature)
- ◆ Above is the reflow profile for Pb free process
- ◆ The peak temperature on the sensor surface must be limited to under 260°C for 10 seconds. Follow solder paste supplier's recommendations for the best SMT quality.
- ◆ When soldering manually or repairing via soldering iron for the accelerometer, the time must be limited to less than 10 seconds and the temperature must not exceed 275°C. If a heat gun is used, the time must be limited to less than 10 seconds and the temperature must not exceed 270°C
- ◆ Avoid bending the PCB after sensor assembly

MARKING ILLUSTRATION AND PACKAGE DRAWING

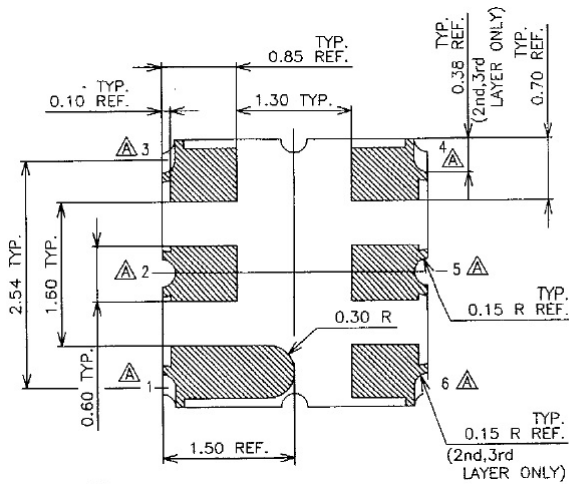
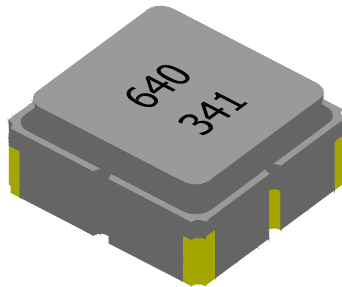
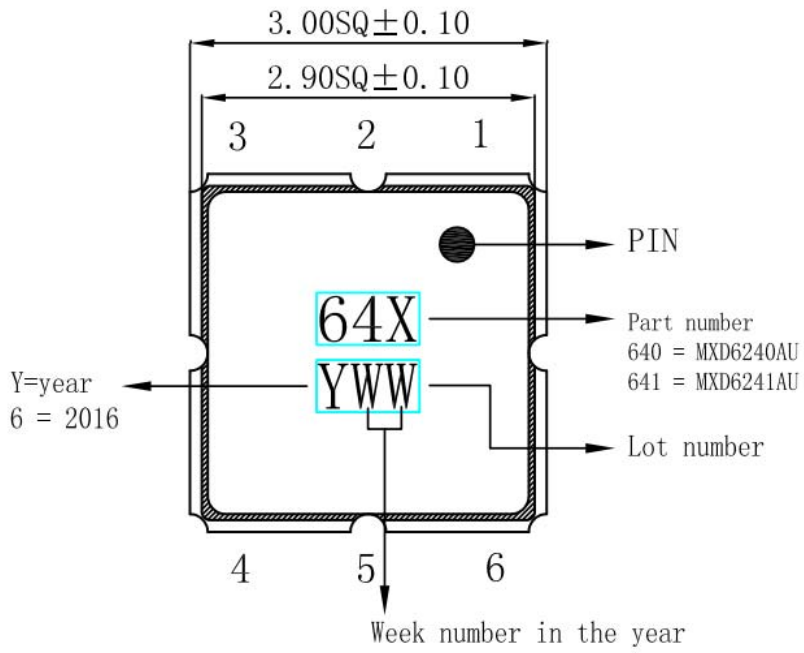



Стандарт Электрон Связь

Мы молодая и активно развивающаяся компания в области поставок электронных компонентов. Мы поставляем электронные компоненты отечественного и импортного производства напрямую от производителей и с крупнейших складов мира.

Благодаря сотрудничеству с мировыми поставщиками мы осуществляем комплексные и плановые поставки широчайшего спектра электронных компонентов.

Собственная эффективная логистика и склад в обеспечивает надежную поставку продукции в точно указанные сроки по всей России.

Мы осуществляем техническую поддержку нашим клиентам и предпродажную проверку качества продукции. На все поставляемые продукты мы предоставляем гарантию .

Осуществляем поставки продукции под контролем ВП МО РФ на предприятия военно-промышленного комплекса России , а также работаем в рамках 275 ФЗ с открытием отдельных счетов в уполномоченном банке. Система менеджмента качества компании соответствует требованиям ГОСТ ISO 9001.

Минимальные сроки поставки, гибкие цены, неограниченный ассортимент и индивидуальный подход к клиентам являются основой для выстраивания долгосрочного и эффективного сотрудничества с предприятиями радиоэлектронной промышленности, предприятиями ВПК и научно-исследовательскими институтами России.

С нами вы становитесь еще успешнее!

Наши контакты:

Телефон: +7 812 627 14 35

Электронная почта: sales@st-electron.ru

Адрес: 198099, Санкт-Петербург,
Промышленная ул, дом № 19, литера Н,
помещение 100-Н Офис 331