

NB3N108K

3.3V Differential 1:8 Fanout Clock Data Driver with HCSL Outputs

Description

The NB3N108K is a differential 1:8 Clock fanout buffer with High-speed Current Steering Logic (HCSL) outputs optimized for ultra low propagation delay variation. The NB3N108K is designed with HCSL PCI Express clock distribution and FBDIMM applications in mind.

Inputs can directly accept differential LVPECL, LVDS, HCSL signals per Figures 7, 8, and 9. Single-ended LVPECL, HCSL, LVCMOS, or LVTTTL levels are accepted with a proper external V_{th} reference supply per Figures 4 and 10. Input pins incorporate separate internal 50 Ω termination resistors allowing additional single ended system interconnect flexibility.

Output drive current is set by connecting a 475 Ω resistor from IREF (Pin 1) to GND per Figure 6. Outputs can also interface to LVDS receivers when terminated per Figure 11.

The NB3N108K specifically guarantees low output-to-output skews. Optimal design, layout, and processing minimize skew within a device and from device to device. System designers can take advantage of the NB3N108K's performance to distribute low skew clocks across the backplane or the motherboard.

Features

- Typical Input Clock Frequency 100, 133, 166, or 400 MHz
- 220 ps Typical Rise and Fall Times
- 800 ps Typical Propagation Delay
- Δt_{pd} 100 ps Maximum Propagation Delay Variation Per Each Diff Pair
- 0.1 ps Typical Integrated Phase Jitter RMS
- Operating Range: $V_{CC} = 3.0$ V to 3.6 V with $V_{EE} = 0$ V
- Differential HCSL Output Levels
- LVDS Output Levels with Interface Termination
- These are Pb-Free Devices

Applications

- Clock Distribution
- PCIe I, II, III
- Networking and Communications
- High End Computing
- Routers

End Products

- Servers
- FBDIMM Memory Card
- Ethernet Switch/Routers



ON Semiconductor®

<http://onsemi.com>

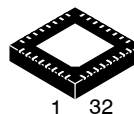

QFN32
MN SUFFIX
CASE 488AM

MARKING DIAGRAM*

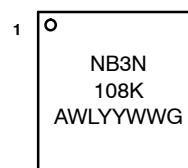

A = Assembly Location
WL = Wafer Lot
YY = Year
WW = Work Week
G = Pb-Free Package

*For additional marking information, refer to

Application Note AND8002/D.

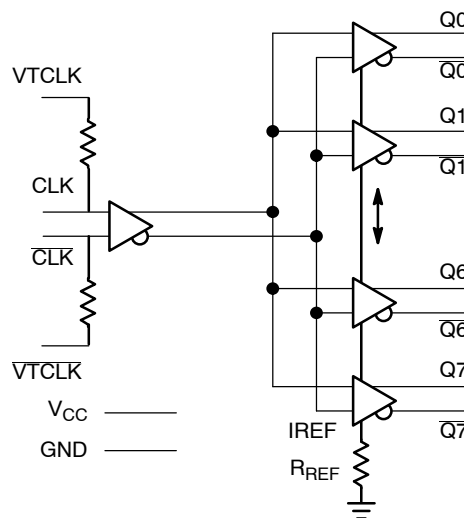

Figure 1. Simplified Logic Diagram

ORDERING INFORMATION

See detailed ordering and shipping information in the package dimensions section on page 8 of this data sheet.

NB3N108K

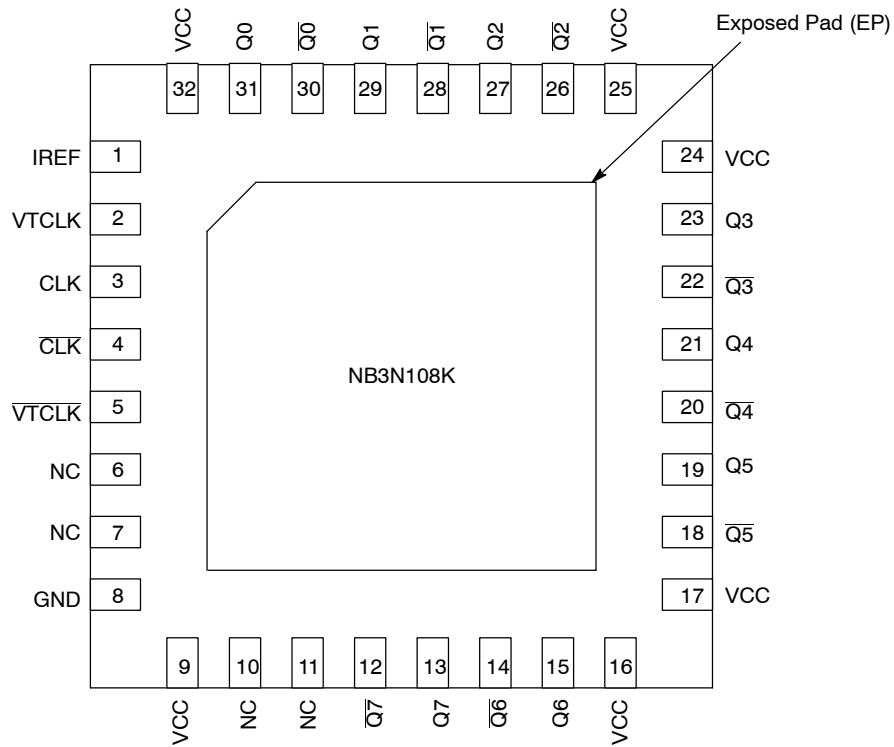

Figure 2. Pinout Configuration (Top View)

Table 1. PIN DESCRIPTION

Pin	Name	I/O	Description
1	IREF		Use the IREF pin to set the output drive. Connect a 475 Ω RREF resistor from the IREF pin to GND to produce 2.6 mA of IREF current. A current mirror multiplies IREF by a factor of 5.4x to force 14 mA through a 50 Ω output load. See Figures 6 and 12.
2, 5	VTCLK, VTCLK	-	Internal 50 Ω Termination Resistor connection Pins. In the differential configuration when the input termination pins are connected to the common termination voltage, and if no signal is applied then the device may be susceptible to self-oscillation.
3	CLK	LVPECL HCSL, LVDS Input	Clock (TRUE) Input
4	$\overline{\text{CLK}}$	LVPECL HCSL, LVDS Input	Clock (INVERT) Input
12, 14, 18, 20, 22, 26, 28, 30	Q[7-0]b	HCSL or LVDS (Note 1) Output	Output (INVERT) (Note 1)
13, 15, 19, 21, 23, 27, 29, 31	Q[7-0]	HCSL or LVDS (Note 1) Output	Output (TRUE) (Note 1)
6, 7, 10, 11	NC		No Connect
8	GND	-	Supply Ground. GND pin must be externally connected to power supply to guarantee proper operation.
9, 16, 17, 24, 25, 32	VCC	-	Positive Voltage Supply pin. VCC pins must be externally connected to a power supply to guarantee proper operation.
Exposed Pad	EP	GND	Exposed Pad. The thermally exposed pad (EP) on package bottom (see case drawing) must be attached to a sufficient heat-sinking conduit for proper thermal operation and electrically connected to the circuit board ground (GND).

1. Outputs can also interface to LVDS receiver when terminated per Figure 11.

NB3N108K

Table 2. ATTRIBUTES

Characteristic		Value
ESD Protection	Human Body Model	>2 kV
	Machine Model	200 V
Moisture Sensitivity (Note 2)	QFN-52	Level 1
Flammability Rating	Oxygen Index: 28 to 34	UL 94 V-0 @ 0.125 in
Transistor Count		286
Meets or exceeds JEDEC Spec EIA/JESD78 IC Latchup Test		

2. For additional information, see Application Note AND8003/D.

Table 3. MAXIMUM RATINGS (Note 3)

Symbol	Parameter	Condition 1	Condition 2	Rating	Unit
V _{CC}	Positive Power Supply	GND = 0 V		4.6	V
V _I	Positive Input	GND = 0 V		GND - 0.3 ≤ V _I ≤ V _{CC}	V
I _{OUT}	Output Current	Continuous Surge		50 100	mA mA
T _A	Operating Temperature Range	QFN32		-40 to +85	°C
T _{stg}	Storage Temperature Range			-65 to +150	°C
θ _{JA}	Thermal Resistance (Junction-to-Ambient) (Note 3)	0 lfpm 500 lfpm	QFN32 QFN32	31 27	°C/W °C/W
θ _{JC}	Thermal Resistance (Junction-to-Case)	2S2P (Note 3)	QFN32	12	°C/W
T _{sol}	Wave Solder Pb-Free			265	°C

Stresses exceeding Maximum Ratings may damage the device. Maximum Ratings are stress ratings only. Functional operation above the Recommended Operating Conditions is not implied. Extended exposure to stresses above the Recommended Operating Conditions may affect device reliability.

3. JEDEC standard 51-6, multilayer board - 2S2P (2 signal, 2 power) with eight filled thermal vias under exposed pad.

NB3N108K

Table 4. DC CHARACTERISTICS ($V_{CC} = 3.0\text{ V to }3.6\text{ V}$, $T_A = -40^\circ\text{C to }+85^\circ\text{C}$ Note 4)

Symbol	Characteristic	Min	Typ	Max	Unit
I_{GND}	GND Supply Current (All Outputs Loaded)		60	90	mA
I_{CC}	Power Supply Current (All Outputs Loaded)		190	230	mA
I_{IH}	Input HIGH Current		2.0	150	μA
I_{IL}	Input LOW Current	-150	-2.0		μA
R_{TIN}	Internal Input Termination Resistor	45	50	55	Ω

DIFFERENTIAL INPUT DRIVEN SINGLE-ENDED

V_{th}	Input Threshold Reference Voltage Range (Note 5)	350		$V_{CC} - 1000$	mV
V_{IH}	Single – Ended Input HIGH Voltage	$V_{th} + 150$		V_{CC}	mV
V_{IL}	Single – Ended Input LOW Voltage	GND		$V_{th} - 150$	mV

DIFFERENTIAL INPUTS DRIVEN DIFFERENTIALLY (Figures 7, 8 and 9)

V_{IHD}	Differential Input HIGH Voltage	425		$V_{CC} - 850$	mV
V_{ILD}	Differential Input LOW Voltage	GND		$V_{CC} - 1000$	mV
V_{ID}	Differential Input Voltage ($V_{IHD} - V_{ILD}$)	150		$V_{CC} - 850$	mV
V_{CMR}	Input Common Mode Range	350		$V_{CC} - 1000$	mV

HCSL OUTPUTS (Figure 4)

V_{OH}	Output HIGH Voltage	600	740	900	mV
V_{OL}	Output LOW Voltage	-150	0	150	mV

NOTE: Device will meet the specifications after thermal equilibrium has been established when mounted in a test socket or printed circuit board with maintained transverse airflow greater than 500 lfm. Electrical parameters are guaranteed only over the declared operating temperature range. Functional operation of the device exceeding these conditions is not implied. Device specification limit values are applied individually under normal operating conditions and not valid simultaneously.

- Measurements taken with with outputs loaded $50\ \Omega$ to GND, see Figure 6. Connect a $475\ \Omega$ resistor from IREF (Pin 1) to GND per Figure 6.
- V_{th} is applied to the complementary input when operating in single ended mode per Figure 4.

NB3N108K

Table 5. AC CHARACTERISTICS $V_{CC} = 3.0\text{ V to }3.6\text{ V}$, $GND = 0\text{ V}$; $-40^{\circ}\text{C to }+85^{\circ}\text{C}$ (Note 6)

Symbol	Characteristic	Min	Typ	Max	Unit
V_{OUTPP}	Output Voltage Amplitude (@ $V_{INPPmin}$) $f_{in} \leq 400\text{ MHz}$		725	1000	mV
t_{PLH} , t_{PHL}	Propagation Delay (See Figure 3a) CLK/CLK to Q_x/\bar{Q}_x	550	800	1100	ps
Δt_{PLH} , Δt_{PHL}	Propagation Delay Variation Per Each Diff Pair (Note 7) (See Figure 3a) CLK/CLK to Q_x/\bar{Q}_x			100	ps
t_{SKEW}	Duty Cycle Skew (Note 8) Within –Device Skew Device to Device Skew (Note 9)			20 100 150	ps
$t_{JIT\phi}$	Integrated Phase Jitter RMS (Note 10)		0.1		ps
V_{INPP}	Input Voltage Swing/Sensitivity (Differential Configuration)	0.150		$V_{CC} - 0.85$	V
V_{CROSS}	Absolute Crossing Magnitude Voltage (See Figure 3b)	250		550	mV
ΔV_{CROSS}	Variation in Magnitude of V_{CROSS} (See Figure 3b)			150	mV
t_r, t_f	Absolute Magnitude in Output Risetime and Falltime (from 175 mV to 525 mV) (See Figure 3b) Q_x, \bar{Q}_x	150	220	400	ps
$\Delta t_r, \Delta t_f$	Variation in Magnitude of Risetime and Falltime (Single-Ended) (See Figure 3b) Q_x, \bar{Q}_x			125	ps

NOTE: Device will meet the specifications after thermal equilibrium has been established when mounted in a test socket or printed circuit board with maintained transverse airflow greater than 500 lpm. Electrical parameters are guaranteed only over the declared operating temperature range. Functional operation of the device exceeding these conditions is not implied. Device specification limit values are applied individually under normal operating conditions and not valid simultaneously.

6. Measured by forcing V_{INPP} (MIN) from a 50% duty cycle. Measurement taken with all outputs loaded $50\ \Omega$ to GND per Figure 6. Connect a $475\ \Omega$ resistor from IREF (Pin 1) to GND per Figure 6.
7. Measured from the input pair crosspoint to each single output pair crosspoint across temp and voltage ranges per Figure 3.
8. Duty cycle skew is measured between differential outputs using the deviations of the sum of T_{pw-} and T_{pw+} .
9. Skew is measured between outputs under identical transition conditions @ 50 MHz.
10. Phase noise integrated from 12 kHz to 20 MHz.

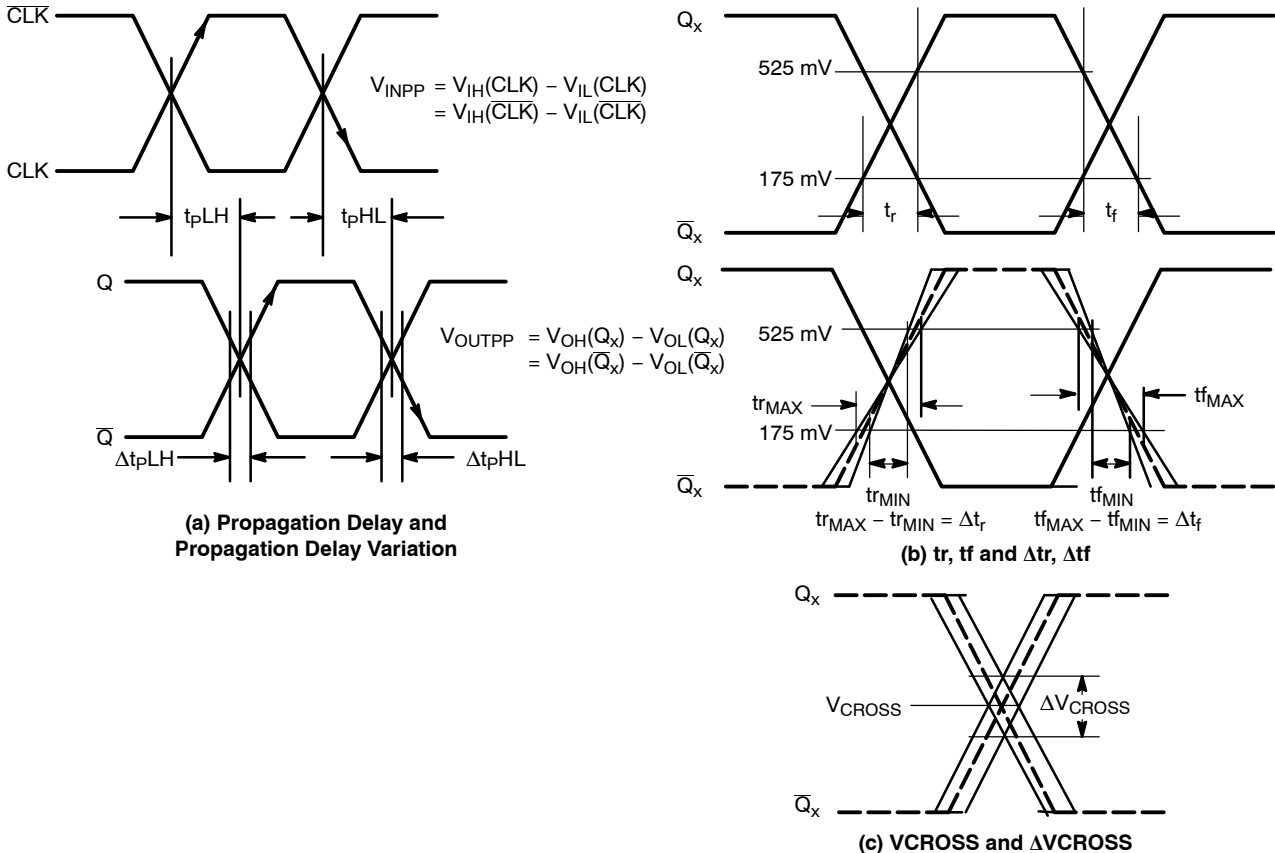

Figure 3. AC Reference Measurement

NB3N108K

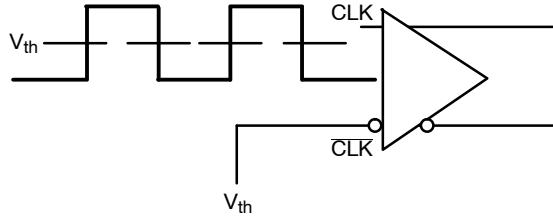

Figure 4. Single-Ended Interconnect V_{th} Reference Voltage

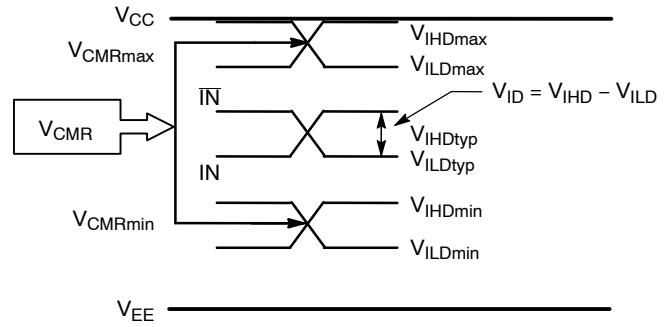
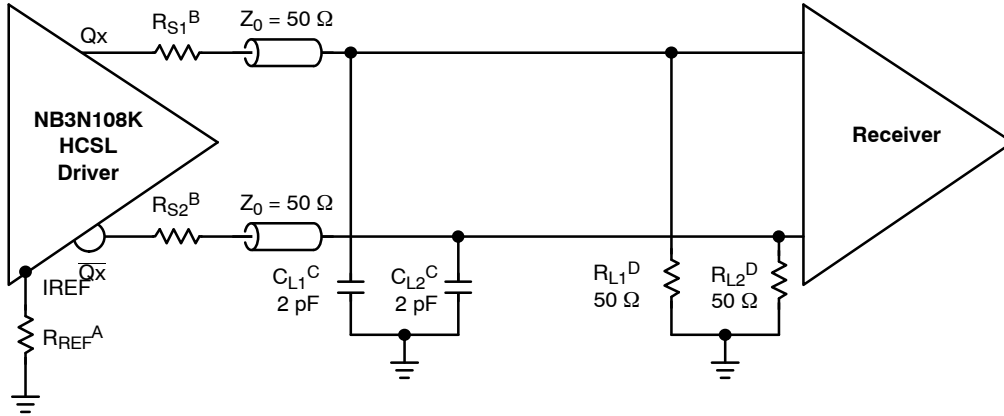
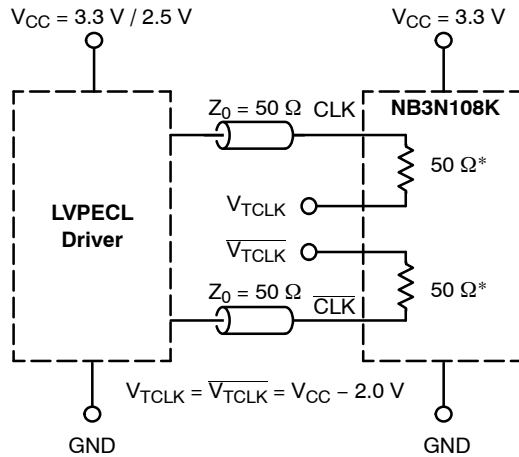

Figure 5. V_{th} Diagram



- A. Connect 475 Ω resistor RREF from IREF pin to GND.
- B. R_{S1} , R_{S2} : 0 Ω for Test and Evaluation. Select to Minimizing Ringing.
- C. C_{L1} , C_{L2} : Receiver Input Simulation (for test only not added to application circuit).
- D. D_{L1} , D_{L2} Termination and Load Resistors Located at Received Inputs.

Figure 6. Typical Termination Configuration for Output Driver and Device Evaluation



*RTIN, Internal Input Termination Resistor

Figure 7. LVPECL Interface

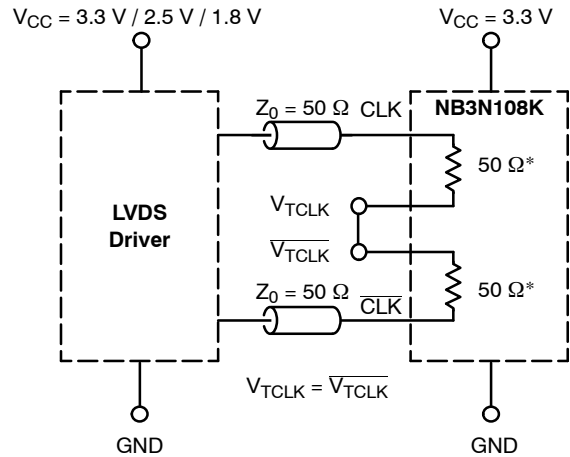

*RTIN, Internal Input Termination Resistor

Figure 8. LVDS Interface

NB3N108K

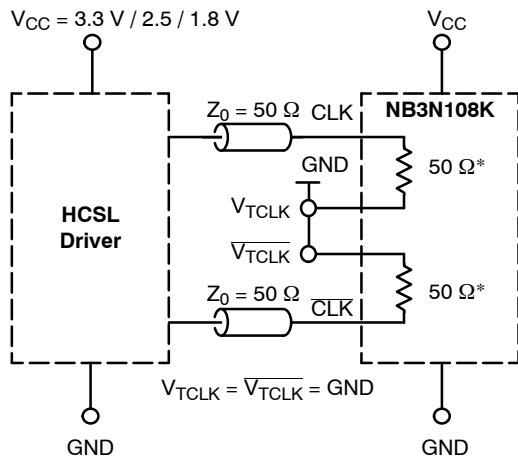

*RTIN, Internal Input Termination Resistor

Figure 9. Standard 50 Ω Load HCSL Interface

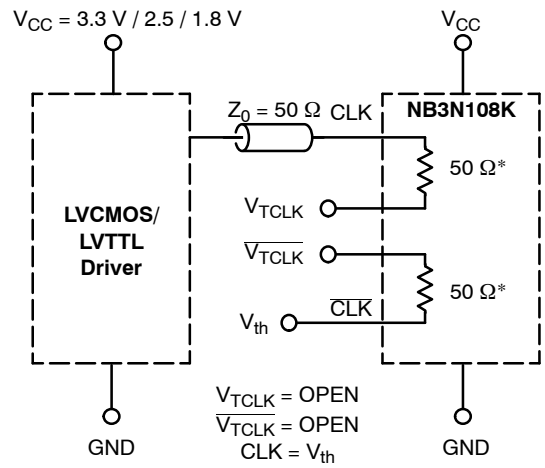

*RTIN, Internal Input Termination Resistor

Figure 10. LVCMOS/LVTTL Interface

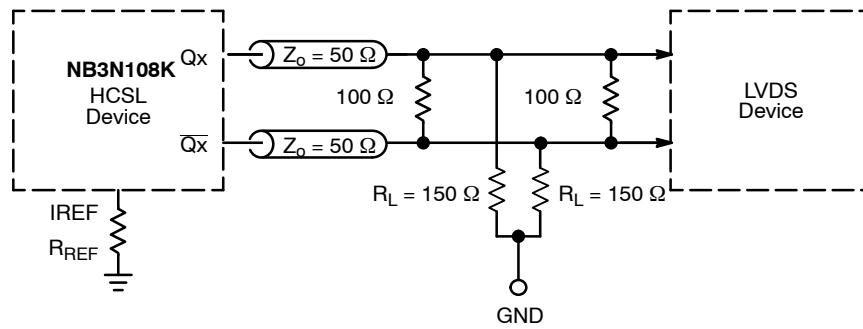

Figure 11. HCSL Interface Termination to LVDS

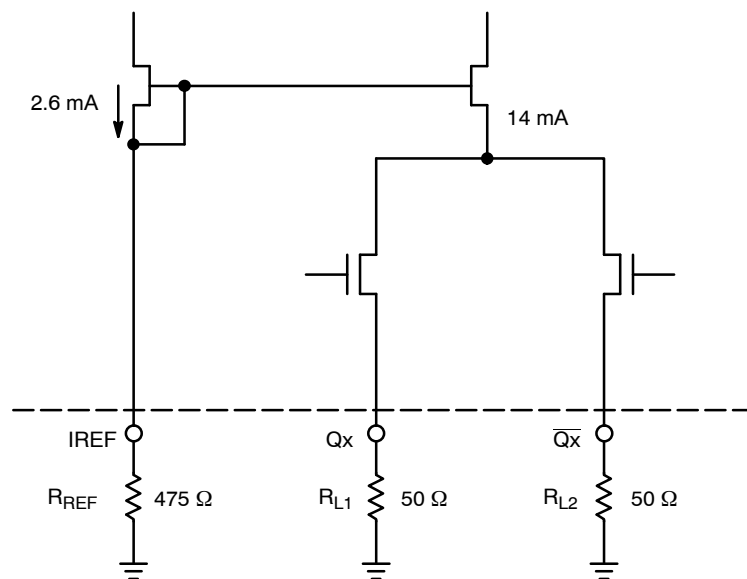

Figure 12. HCSL Simplified Output Structure

NB3N108K

ORDERING INFORMATION

Device	Package	Shipping†
NB3N108KMNG	QFN32 (Pb-Free)	74 Units / Rail
NB3N108KMNR4G	QFN32 (Pb-Free)	1000 / Tape & Reel

†For information on tape and reel specifications, including part orientation and tape sizes, please refer to our Tape and Reel Packaging Specifications Brochure, BRD8011/D.

NB3N108K

PACKAGE DIMENSIONS

QFN32 5*5*1 0.5 P
CASE 488AM-01
ISSUE O

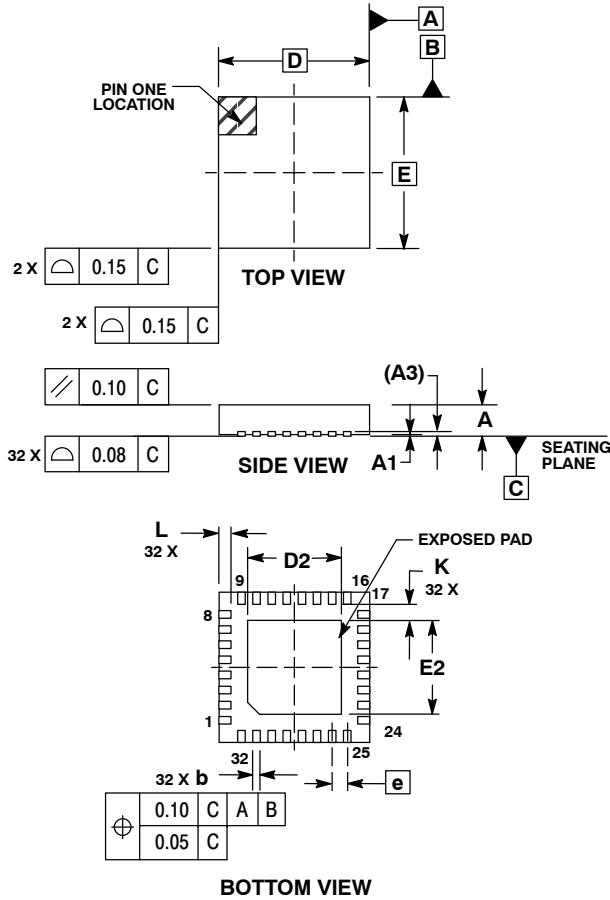

NOTES:

1. DIMENSIONS AND TOLERANCING PER ASME Y14.5M, 1994.
2. CONTROLLING DIMENSION: MILLIMETERS.
3. DIMENSION b APPLIES TO PLATED TERMINAL AND IS MEASURED BETWEEN 0.25 AND 0.30 MM TERMINAL
4. COPLANARITY APPLIES TO THE EXPOSED PAD AS WELL AS THE TERMINALS.

MILLIMETERS			
DIM	MIN	NOM	MAX
A	0.800	0.900	1.000
A1	0.000	0.025	0.050
A3	0.200 REF		
b	0.180	0.250	0.300
D	5.00 BSC		
D2	2.950	3.100	3.250
E	5.00 BSC		
E2	2.950	3.100	3.250
e	0.500 BSC		
K	0.200	---	---
L	0.300	0.400	0.500

SOLDERING FOOTPRINT*

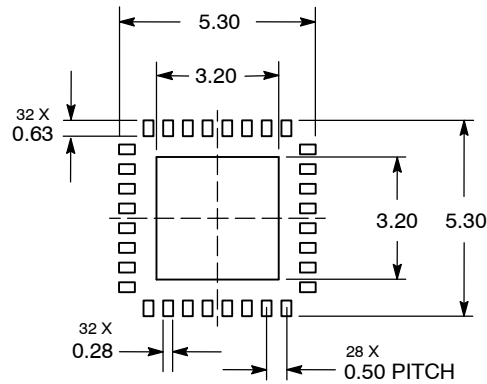

*For additional information on our Pb-Free strategy and soldering details, please download the ON Semiconductor Soldering and Mounting Techniques Reference Manual, SOLDERRM/D.

ON Semiconductor and are registered trademarks of Semiconductor Components Industries, LLC (SCILLC). SCILLC reserves the right to make changes without further notice to any products herein. SCILLC makes no warranty, representation or guarantee regarding the suitability of its products for any particular purpose, nor does SCILLC assume any liability arising out of the application or use of any product or circuit, and specifically disclaims any and all liability, including without limitation special, consequential or incidental damages. "Typical" parameters which may be provided in SCILLC data sheets and/or specifications can and do vary in different applications and actual performance may vary over time. All operating parameters, including "Typicals" must be validated for each customer application by customer's technical experts. SCILLC does not convey any license under its patent rights nor the rights of others. SCILLC products are not designed, intended, or authorized for use as components in systems intended for surgical implant into the body, or other applications intended to support or sustain life, or for any other application in which the failure of the SCILLC product could create a situation where personal injury or death may occur. Should Buyer purchase or use SCILLC products for any such unintended or unauthorized application, Buyer shall indemnify and hold SCILLC and its officers, employees, subsidiaries, affiliates, and distributors harmless against all claims, costs, damages, and expenses, and reasonable attorney fees arising out of, directly or indirectly, any claim of personal injury or death associated with such unintended or unauthorized use, even if such claim alleges that SCILLC was negligent regarding the design or manufacture of the part. SCILLC is an Equal Opportunity/Affirmative Action Employer. This literature is subject to all applicable copyright laws and is not for resale in any manner.

PUBLICATION ORDERING INFORMATION

LITERATURE FULFILLMENT:
Literature Distribution Center for ON Semiconductor
P.O. Box 5163, Denver, Colorado 80217 USA
Phone: 303-675-2175 or 800-344-3860 Toll Free USA/Canada
Fax: 303-675-2176 or 800-344-3867 Toll Free USA/Canada
Email: orderlit@onsemi.com

N. American Technical Support: 800-282-9855 Toll Free USA/Canada
Europe, Middle East and Africa Technical Support:
Phone: 421 33 790 2910
Japan Customer Focus Center
Phone: 81-3-5817-1050

ON Semiconductor Website: www.onsemi.com
Order Literature: <http://www.onsemi.com/orderlit>
For additional information, please contact your local Sales Representative



Стандарт Электрон Связь

Мы молодая и активно развивающаяся компания в области поставок электронных компонентов. Мы поставляем электронные компоненты отечественного и импортного производства напрямую от производителей и с крупнейших складов мира.

Благодаря сотрудничеству с мировыми поставщиками мы осуществляем комплексные и плановые поставки широчайшего спектра электронных компонентов.

Собственная эффективная логистика и склад в обеспечивает надежную поставку продукции в точно указанные сроки по всей России.

Мы осуществляем техническую поддержку нашим клиентам и предпродажную проверку качества продукции. На все поставляемые продукты мы предоставляем гарантию .

Осуществляем поставки продукции под контролем ВП МО РФ на предприятия военно-промышленного комплекса России , а также работаем в рамках 275 ФЗ с открытием отдельных счетов в уполномоченном банке. Система менеджмента качества компании соответствует требованиям ГОСТ ISO 9001.

Минимальные сроки поставки, гибкие цены, неограниченный ассортимент и индивидуальный подход к клиентам являются основой для выстраивания долгосрочного и эффективного сотрудничества с предприятиями радиоэлектронной промышленности, предприятиями ВПК и научно-исследовательскими институтами России.

С нами вы становитесь еще успешнее!

Наши контакты:

Телефон: +7 812 627 14 35

Электронная почта: sales@st-electron.ru

Адрес: 198099, Санкт-Петербург,
Промышленная ул, дом № 19, литера Н,
помещение 100-Н Офис 331