

# FRDM-KE02Z40M User's Guide

## 1 Overview

The Freescale Freedom Development Platform is an evaluation and development tool ideal for rapid prototyping of microcontroller-based applications. The hardware design is form-factor compatible with popular third-party hardware designed to work with Arduino™ and Arduino-compatible boards.

The Freescale KE02Z Freedom Board (FRDM-KE02Z40M) is a simple, yet sophisticated design featuring the Kinetis E Series microcontroller KE02Z64VQH4, the industry's first 5 V microcontroller built on the ARM® Cortex®-M0+ core.

The Kinetis E series is the most scalable portfolio of low-power, high-robustness, mixed signal 32-bit ARM Cortex-M0+ MCUs running up to 48 MHz in the industry. It supports power supply voltage range from 2.7–5.5 V, ambient operating temperature range from –40 °C to 105 °C and includes up to 64 KB flash memory.

## Contents

1	Overview .....	1
2	Getting started.....	2
3	FRDM-KE02Z40M hardware overview ...	2
4	FRDM-KE02Z40M hardware description.	4
4.1	Power supply .....	4
4.2	Serial and Debug Adapter (SDA).....	6
4.3	KE02Z microcontroller .....	8
4.4	Clock source.....	8
4.5	Thermistor .....	9
4.6	Infrared port.....	10
4.7	Capacitive touch slider .....	11
4.8	Three-axis accelerometer .....	11
4.9	RGB LED.....	12
4.10	Input/Output headers .....	13
4.11	Arduino compatibility.....	13
5	References .....	13
6	Revision history .....	14

The FRDM-KE02Z40M includes the Freescale open standard embedded serial and debug adapter known as OpenSDA. This circuit offers several options to the users for serial communications, flash programming, and run-control debugging.

Some of the software development tool options available to the user are given below.

- CodeWarrior for Microcontrollers
- IAR Embedded Workbench
- Keil MDK featuring the  $\mu$ Vision IDE
- Atollic TrueSTUDIO, Rowley Crossworks, and others.

The features given below combine to give freedom needed by the user to rapidly prototype many embedded designs:

- Powerful microcontroller built on a very low-power core and SoC platform
- Easy access to I/O with a large ecosystem of compatible hardware
- Flexible programming and debug interface
- Large ecosystem of software development environments

## 2 Getting started

See the FRDM-KE02Z40M Quick Start Package for step-by-step instructions for getting started with the FRDM-KE02Z40M freedom board. See the Jump Start Your Design section on [freescale.com](http://freescale.com) for the Quick Start Package and software lab guides.

## 3 FRDM-KE02Z40M hardware overview

The FRDM-KE02Z40M hardware is a Freescale Freedom Development Platform microcontroller board assembled with the following features:

- Kinetis E Series KE02 family MCU in an 64 QFP package (14x14 document number: 98ASB42844B)
- Onboard Serial and Debug Adapter (OpenSDA)
- I/O headers for easy access to MCU I/O pins
- Freescale inertial sensor, MMA8451Q
- Capacitive touch slider
- Reset pushbutton
- RGB LED

- Infrared communication
- One thermistor
- Motor control function interface for simple BLDC motor control

Figure 1 shows a block diagram of the FRDM-KE02Z40M board.

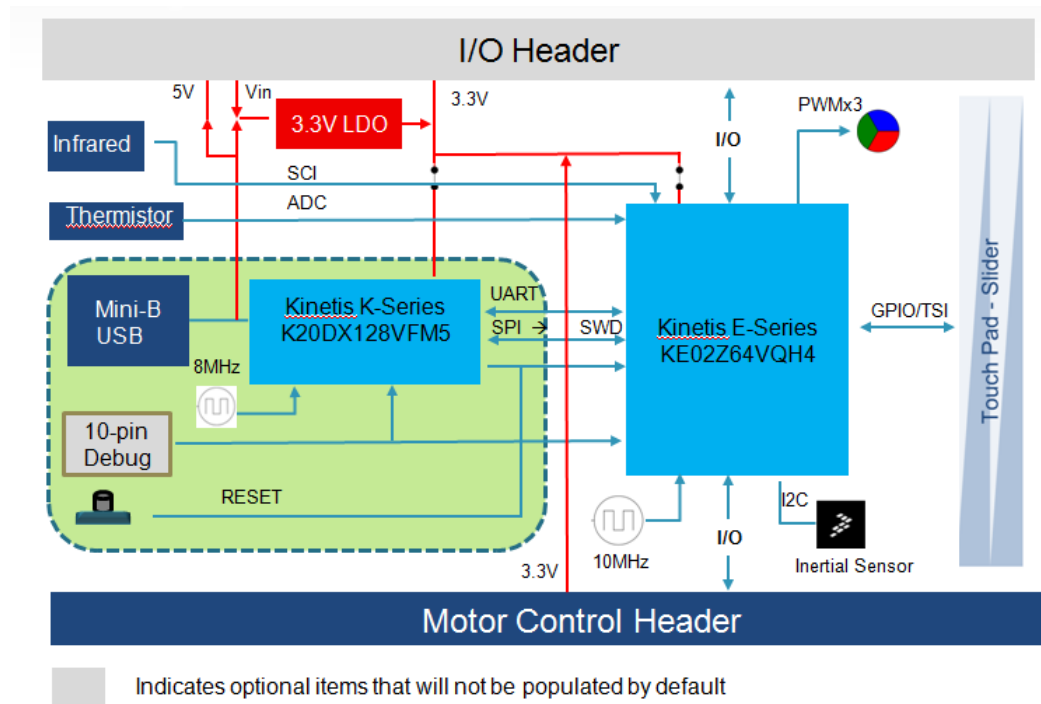

Figure 1. FRDM-KE02Z40M block diagram

The FRDM-KE02Z40M features two microcontrollers (MCUs):

- The target MCU: The target MCU is KE02Z64VQH4, a device of the Kinetis E Series family.
- A Serial and Debug Adapter (OpenSDA) MCU: The OpenSDA MCU is K20DX128VFM5, a device of the Kinetis K Series K20 family.

Features of the KE02Z64 target MCU are listed below.

- 32-bit ARM Cortex-M0+ core
  - Up to 40 MHz operation
  - Single-cycle fast I/O access port
- Memories
  - 64 KB flash and 256B D-flash as EEPROM
  - 4 KB SRAM
- System integration
  - Power management and mode controllers
  - Low-leakage wake-up unit
  - Bit manipulation engine (BME) for read-modify-write peripheral operations

- Clocks
  - Clock generation module with FLL for system and CPU clock generation
  - 32 kHz internal reference clock
  - System oscillator supporting external crystal or resonator
  - Low-power 1 kHz RC oscillator for RTC and watchdog
- Analog peripherals
  - 12-bit SAR ADC
  - Two analog comparators
- Communication peripherals
  - Two 8-bit Serial Peripheral Interfaces (SPI)
  - one I2C modules
  - Three UART modules
- Timers
  - One 6-channel FlexTimer module
  - Two 2-channel Timer/PWM modules
  - 2-channel Periodic Interrupt Timer (PIT)
  - Real time clock (RTC)
  - System tick timer
  - One watchdog module
- Security
  - One CRC
- Human-Machine Interfaces (HMI)
  - General-purpose input/output controller
  - IRQ

## 4 FRDM-KE02Z40M hardware description

### 4.1 Power supply

The FRDM-KE02Z40M offers a design with multiple power supply options. It can be powered from the USB connector, the  $V_{IN}$  pin on the I/O header, an off-board 1.71–3.6 V supply from the 3.3 V pin on the I/O header, or 3.3 V (P3V3\_MOTOR) from I/O header provided by motor control board. The USB and  $V_{IN}$  supplies are regulated onboard using a 3.V linear regulator to produce the main power supply. The other two sources are not regulated onboard. The following figure shows the schematic drawing for the power supply inputs and the onboard voltage regulator.

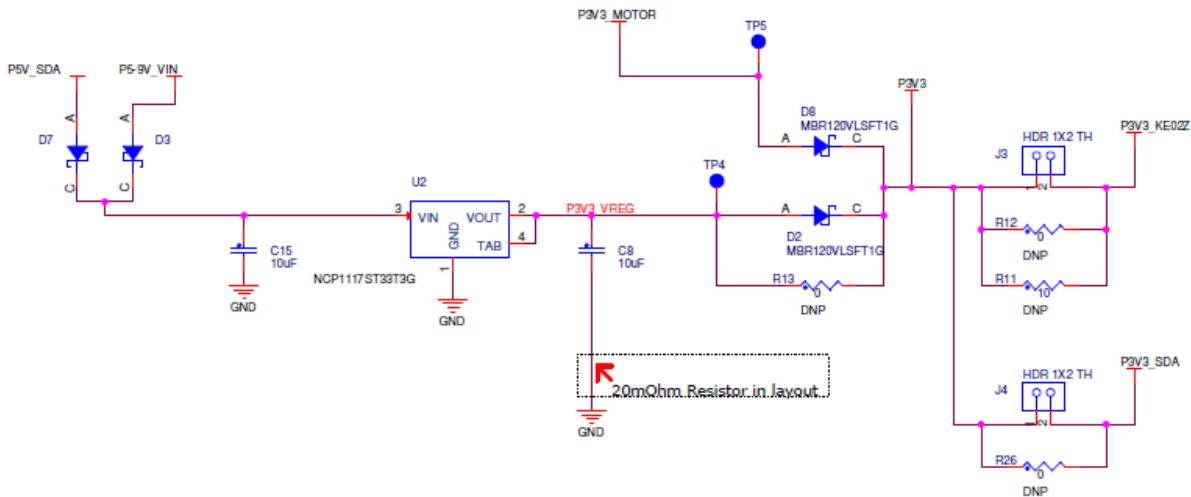

Figure 2. FRDM-KE02Z40M power supply

Table 1 provides the operational details and requirements for the power supplies.

Table 1. Power supply requirements

Supply source	Valid range	Operational SDA	Onboard regulation
OpenSDA USB (J6)	5V	Yes	Yes
V <sub>IN</sub> pin on I/O header	4.3–9 V	Yes	Yes
P3V3 3.3 V pin on I/O header	1.71–3.6 V	Yes	No
P3V3_MOTOR pin on I/O header	3.3 V	Yes	No

**Note:** The OpenSDA circuit is operational only when a USB cable is connected and is supplying power to OpenSDA USB connector (header J6). However, the protection circuitry is in place to allow multiple sources to be powered at one time.

Table 2. FRDM-KE02Z40M power supplies

Power supply option	Description
P5-9V_VIN	Power supplied from the V <sub>IN</sub> pin of the I/O headers (J9 pin 16)
P5V_SDA	Power supplied from the OpenSDA USB connector (J6)

P3V3_VREG	Regulated 3.3 V supply Sources power to the P3V3 supply rail through a back drive protection Schottky diode.
P3V3	Main supply rail for the board Can be sourced from P3V3_VREG, or directly from the I/O headers (J9 pin 8), or from P3V3_MOTOR.
P3V3_KE02Z	KE02Z MCU power supply Header J3 provides a convenient means for KE02Z energy consumption measurements.
P3V3_SDA	OpenSDA circuit power supply Header J4 provides a convenient means for K20 energy consumption measurements.
P5V_USB	Nominal 5 V supplied to the I/O headers (J9 pin 10). Sourced from P5V_SDA supply through a back drive protection Schottky diode.
P3V3_MOTOR	3.3 V supply from I/O header provided by motor control board

Notes:

- 1) Headers J3 and J4 are not populated by default on the production version. The two pins of these headers are shorted together by 0-ohm resistors, R12 and R26 on the PCB. To measure the energy consumption of either the KE02Z64 or the OpenSDA MCU, the 0-ohm resistor between these pins must be first cut off. A current probe or a shunt resistor and voltage meter can then be applied to measure the energy consumption on these rails. When the MCU current measurement is done with no further need, this 0-ohm resistor can be soldered on again.
- 2) To better get ADC accuracy on KE02Z64, it is recommended that the 0-ohm resistor R13 be soldered on and ensure there is no power supply from P3V3\_MOTOR and P3V3 sourced from I/O headers.

## 4.2 Serial and Debug Adapter (SDA)

OpenSDA is an open-standard serial and debug adapter. It bridges serial and debug communications between a USB host and an embedded target processor as shown in [Figure 3](#). The hardware circuit is based on a Freescale Kinetis K20 family microcontroller (MCU) with 128 KB of embedded flash memory and an integrated USB controller. OpenSDA features a mass storage device (MSD) bootloader, which provides a quick and easy mechanism for loading different OpenSDA applications such as flash programmers, run-control debug interfaces, serial-to-USB converters, among others. Two or more OpenSDA applications can run simultaneously. For example, run-control debug application and serial-

to-USB converter run in parallel to provide a virtual COM communication interface while allowing code debugging via OpenSDA with just single USB connection. These two applications are provided in a single code package.

See to the *OpenSDA User's Guide*, available on [freescale.com](http://freescale.com), for more details.

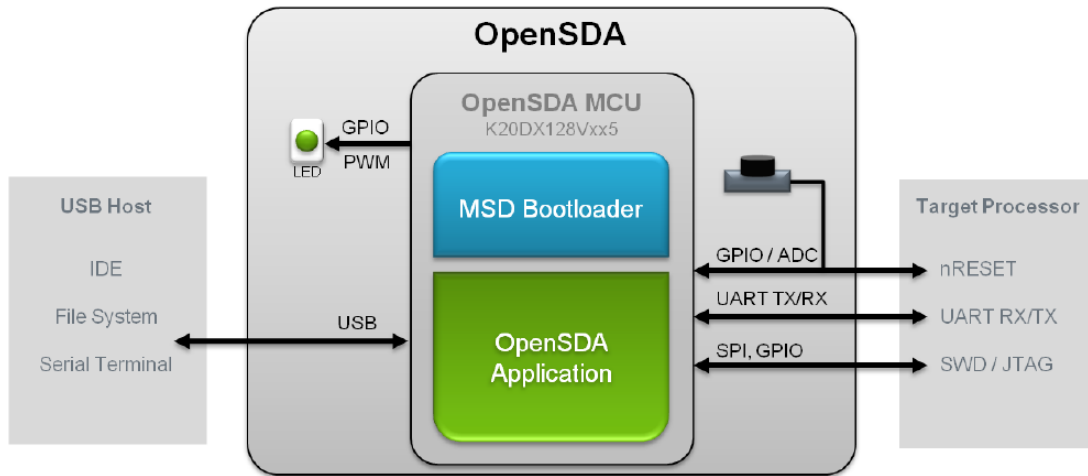

Figure 3. OpenSDA block diagram

OpenSDA is managed by a Kinetis K20 MCU built on the ARM Cortex-M4 core. The OpenSDA circuit includes a status LED (D4) and a RESET pushbutton (SW1). The pushbutton asserts the Reset signal to the KE02Z target MCU. It can also be used to place the OpenSDA circuit into Bootloader mode by holding down the RESET pushbutton while plugging the USB cable to USB connector J6. Once the OpenSDA enters bootloader mode, other OpenSDA applications such as debug application can be programmed.

SPI and GPIO signals provide an interface to the SWD debug port of the KE02Z. Additionally, signal connections are available to implement a UART serial channel. The OpenSDA circuit receives power when the USB connector J6 is plugged into a USB host.

#### 4.2.1 Debugging interface

Signals with SPI and GPIO capability are used to connect directly to the SWD of the KE02Z. These signals are also brought out to a standard 10-pin (0.05”) Cortex Debug connector (J7) as shown in [Figure 4](#). It is possible to isolate the KE02Z MCU from the OpenSDA circuit and use J7 to connect to an off-board MCU. To accomplish this, cut off the 0-ohm resistor R58. This will disconnect the SWD\_CLK pin to the KE02Z so that it will not interfere with the communications to an off-board MCU connected to J7.

## SWD CONNECTOR

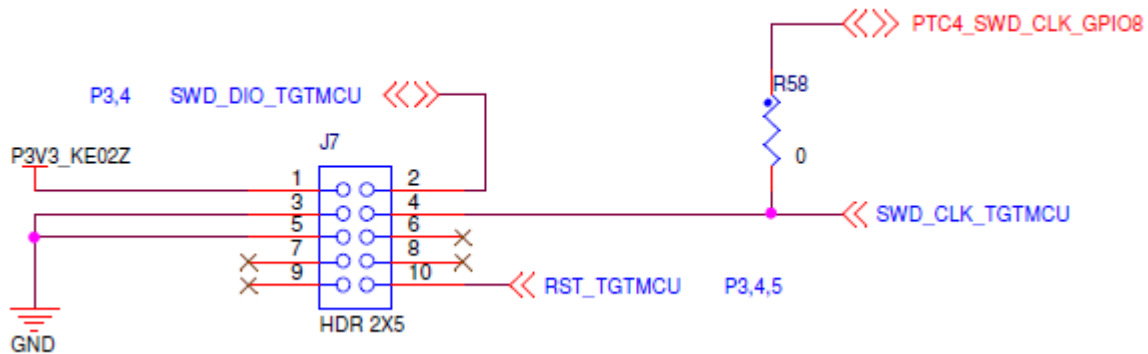

Figure 4. SWD debug connector to KE02Z

### 4.2.2 Virtual serial port

A serial port connection is available between the OpenSDA MCU and UART1 pin PTC7 (TXD1) and PTC6 (RXD1) of KE02Z. Several of the default OpenSDA applications provided by Freescale, including the MSD Flash Programmer and the P&E Debug Application, provide a USB Communications Device Class (CDC) interface that bridges serial communications between the USB host and this serial interface on the KE02Z.

## 4.3 KE02Z microcontroller

### 4.4 Clock source

The Kinetis KE02 microcontrollers feature an on-chip oscillator compatible with two ranges of input crystal or resonator frequencies: 32 kHz (low-frequency mode), 4–20 MHz (high-frequency mode).

The KE02Z64 on the FRDM-KE02Z40M is clocked from a 10 MHz crystal.

#### 4.4.1 Serial port

The serial port interface signals used with OpenSDA are UART1 pin PTC7 (TXD1) and PTC6 (RXD1). These signals are also connected to I/O header J1.

#### 4.4.2 Reset

The PTA5/RESET signal on the KE02Z is connected externally to a pushbutton, SW1. The Reset button can be used to force an external reset event in the target MCU. The reset button can also be used to force the OpenSDA circuit into bootloader mode when plugging the USB cable to J6. Please refer to the [Serial and Debug Adapter](#) section for more details.

#### 4.4.3 Debug

The sole debug interface on all Kinetis E Series devices is a Serial Wire Debug (SWD) port. The primary controller of this interface on the FRDM-KE02Z40M is the onboard OpenSDA circuit.



However, a 2x5-pin (0.05") **Cortex Debug connector**, J7, provides access to the SWD signals for the KE02Z MCU. The following table shows SWD connector signals description for KE02Z:

**Table 3. ARM JTAG/SWD mini connector description**

Pin	Function	Connection to KE02Z
1	VTref	3.3V system power supply (V_BRD)
2	SWDIO/TMS	PTA4/SWD_DIO
3	GND	GND
4	SWDCLK/TC K	PTC4/SWD_CLK
5	GND	GND
6	SWO/TDO	NC
7	NC	NC
8	TDI	NC
9	NC	NC
10	RESET	PTA5/RESET

## 4.5 Thermistor

One thermistor (RT1) is connected to two ADC inputs (PTF4/ADP12, PTF5/ADP13) of KE02Z for evaluating the ADC module. See the following figure.

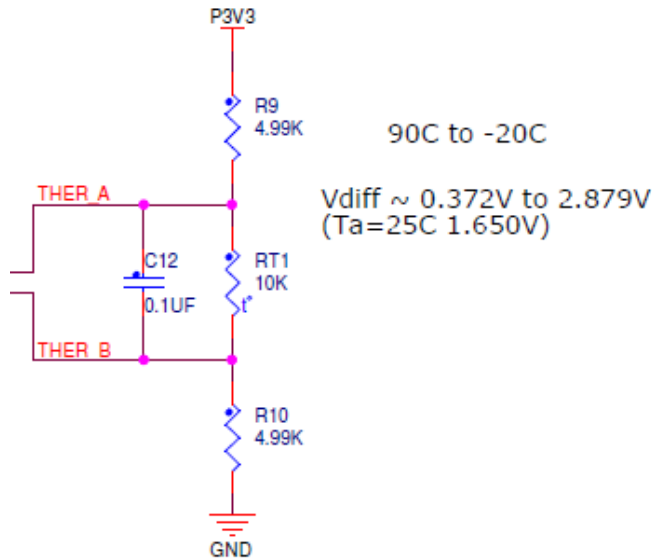

Figure 5. Thermistor connection

## 4.6 Infrared port

One infrared RX port and one TX port (as shown in Figure 6) are connected to ACMP0 input pin (ACMP0\_IN1) and SCI0 TXD0 pin of KE02Z to demonstrate the capability of SCI0 modulated by FlexTimer for generating infrared signals and use ACMP0 as a filter to receive the SCI data via infrared signal.

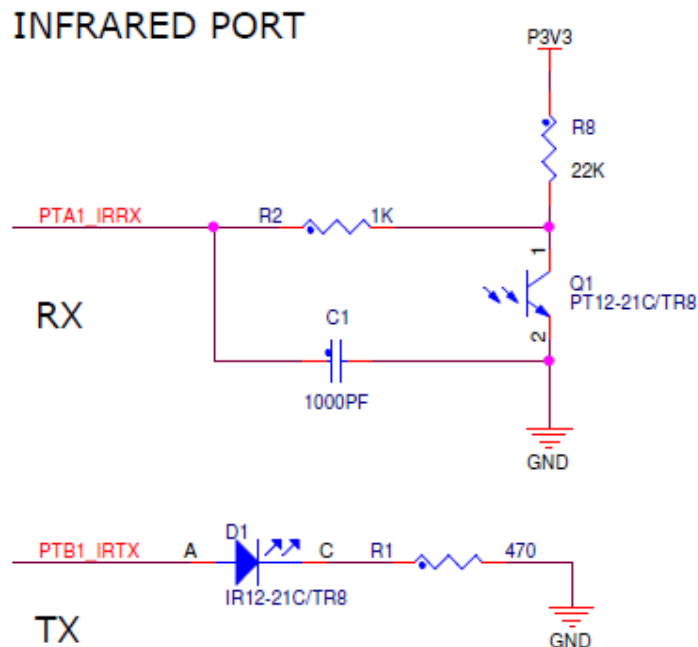

Figure 6. Infrared connection

## 4.7 Capacitive touch slider

Two GPIO pins functioning as Touch Sense Input (TSI) signals, are connected to capacitive electrodes configured as a touch slider as shown in the following figure.

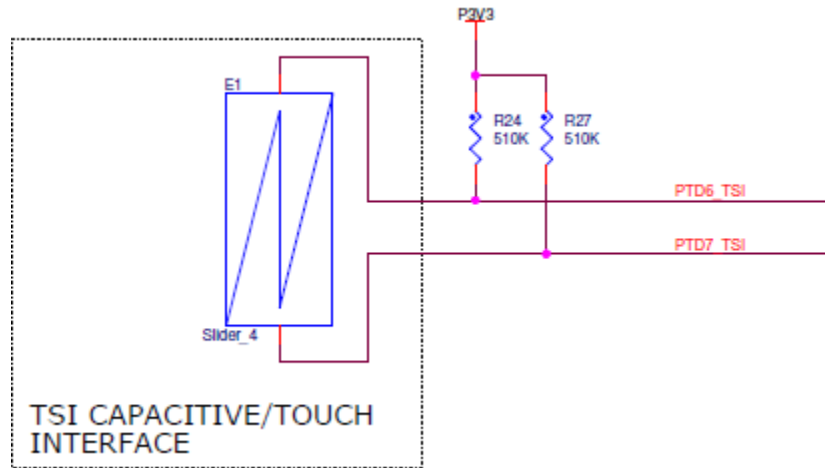

Figure 7. Touch slider connection

## 4.8 Three-axis accelerometer

A Freescale MMA8451Q low-power, three-axis accelerometer is interfaced through an I<sup>2</sup>C bus and two GPIO signals as shown in Table 4. By default, the I<sup>2</sup>C address is 0x1D (SA0 pulled high). Figure 8 shows the accelerometer connection.

Table 4. Accelerometer signal connections

MMA8451Q	KE02Z
SCL	PTA3
SDA	PTA2
INT1	PTD4
INT2	PTD3

## I2C INERTIAL SENSOR

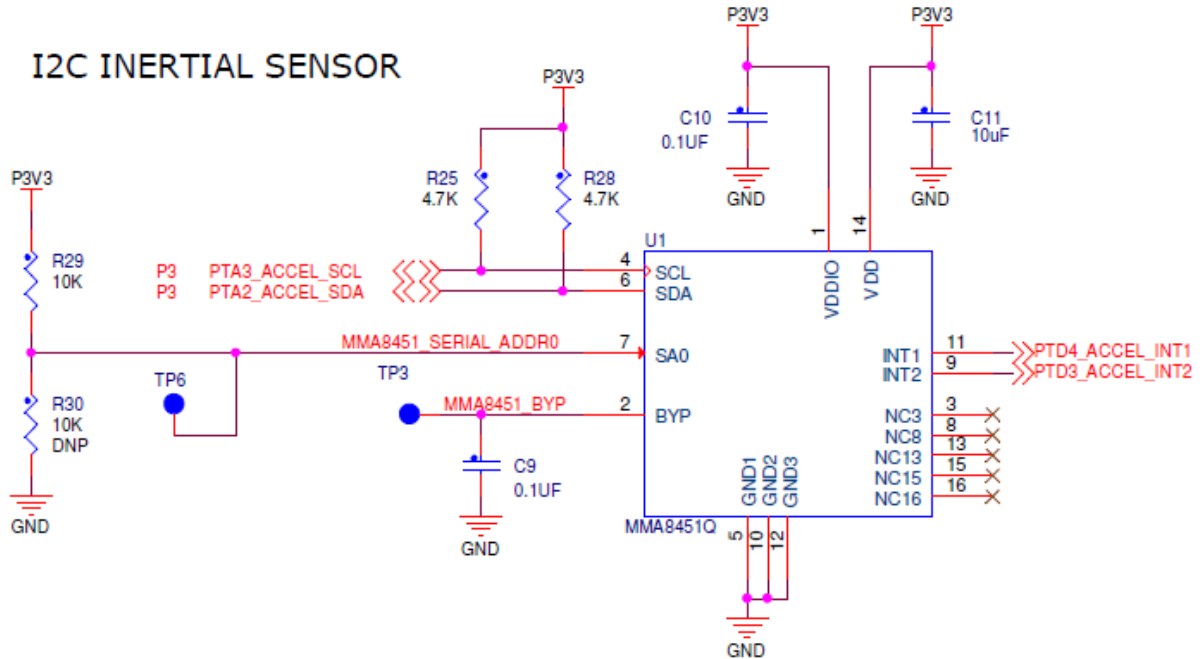

Figure 8. Accelerometer connection

## 4.9 RGB LED

Three PWM-capable KE02Z signals are connected to the red, green, and blue (RGB) LEDs. The signal connections are shown in the table given below. Figure 9 shows the RGB LED connections.

Table 5. RGB LED signal connections

RGB LED	KE02Z
Red Cathode	PTH1/FTM2CH1
Green Cathode	PTH2/FTM1CH0
Blue Cathode	PTE7/FTM1CH1

## RGB LED FEATURE

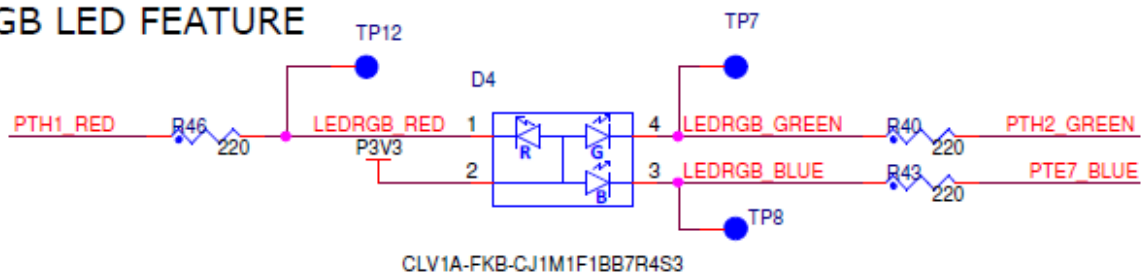

Figure 9. RGB LED connection

## 4.10 Input/Output headers

The KE02Z64 microcontroller is packaged in a 64-pin QFP package. Some pins are utilized in onboard circuitry, but many are directly connected to one of four I/O headers (J1, J2, J9 and J10). Headers J1 and J2 also function as motor control headers to provide access to a motor control board such as simple BLDC motor driving board APMOTOR56F8000E.

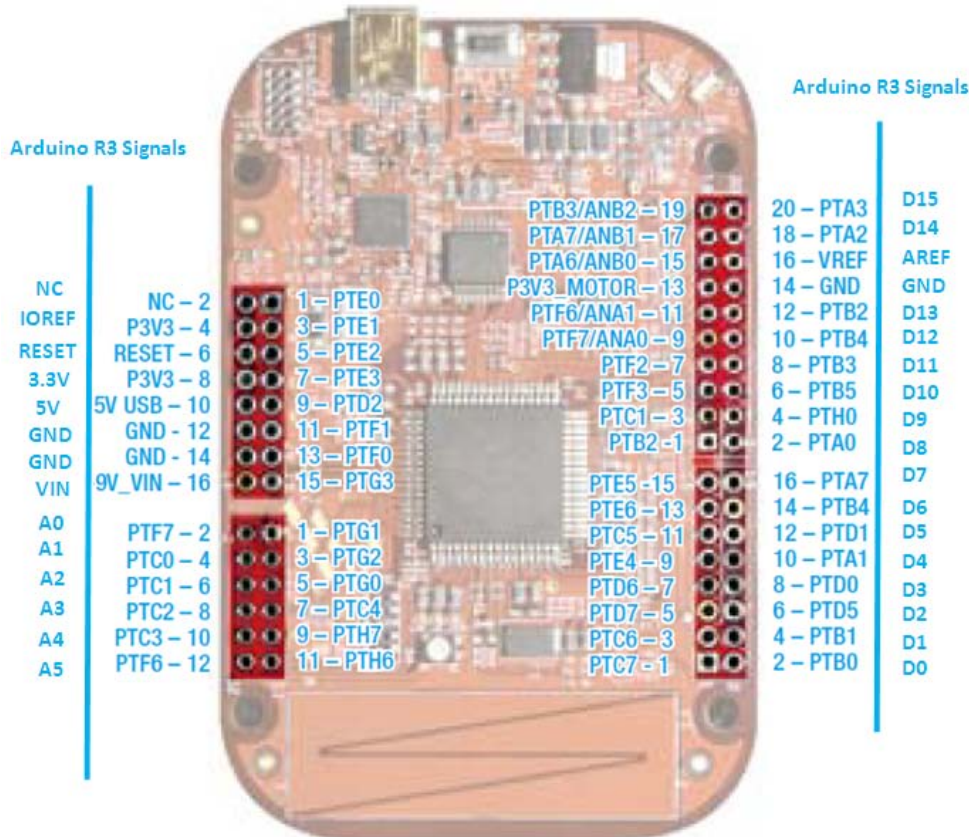

Figure 10. I/O headers

## 4.11 Arduino compatibility

The I/O headers on the FRDM-KE02Z40M are arranged to allow compatibility with peripheral boards (known as shields) that connect to Arduino and Arduino-compatible microcontroller boards. The pins on the headers share the same mechanical spacing and placement as the I/O headers on the Arduino Uno Revision 3 board design. See Figure 10 for compatible signals.

## 5 References

- OpenSDA User's Guide, available on [freescale.com](http://freescale.com), is a guide for users of the OpenSDA embedded circuit.

- KE02 Sub-Family Reference, available on [freescale.com](http://freescale.com), is a reference manual for KE02 sub-family devices.
- Arduino Overview, available on [arduinoBoardUno](http://arduinoBoardUno), is a guide of Arduion platform.
- Arduino Uno, available on [arduinoBoardUno](http://arduinoBoardUno), is a guide of Arduion Uno revision.

## 6 Revision history

Revision	Date	Substantial changes
0	03/2014	Initial release

**How to Reach Us:**

**Home Page:**  
[freescale.com](http://freescale.com)

**Web Support:**  
[freescale.com/support](http://freescale.com/support)

Information in this document is provided solely to enable system and software implementers to use Freescale products. There are no express or implied copyright licenses granted hereunder to design or fabricate any integrated circuits based on the information in this document. Freescale reserves the right to make changes without further notice to any products herein.

Freescale makes no warranty, representation, or guarantee regarding the suitability of its products for any particular purpose, nor does Freescale assume any liability arising out of the application or use of any product or circuit, and specifically disclaims any and all liability, including without limitation consequential or incidental damages. "Typical" parameters that may be provided in Freescale data sheets and/or specifications can and do vary in different applications, and actual performance may vary over time. All operating parameters, including "typicals," must be validated for each customer application by customer's technical experts. Freescale does not convey any license under its patent rights nor the rights of others. Freescale sells products pursuant to standard terms and conditions of sale, which can be found at the following address:  
[freescale.com/SalesTermsandConditions](http://freescale.com/SalesTermsandConditions).

Freescale, the Freescale logo, and Kinetis are trademarks of Freescale Semiconductor, Inc., Reg. U.S. Pat. & Tm. Off. All other product or service names are the property of their respective owners. ARM and Cortex are registered trademarks of ARM Limited (or its subsidiaries) in the EU and/or elsewhere. All rights reserved.

© 2014 Freescale Semiconductor, Inc.



Document Number: FRDMKE02Z40MUG  
Rev. 0, 03/2014





## Стандарт Электрон Связь

Мы молодая и активно развивающаяся компания в области поставок электронных компонентов. Мы поставляем электронные компоненты отечественного и импортного производства напрямую от производителей и с крупнейших складов мира.

Благодаря сотрудничеству с мировыми поставщиками мы осуществляем комплексные и плановые поставки широчайшего спектра электронных компонентов.

Собственная эффективная логистика и склад в обеспечивает надежную поставку продукции в точно указанные сроки по всей России.

Мы осуществляем техническую поддержку нашим клиентам и предпродажную проверку качества продукции. На все поставляемые продукты мы предоставляем гарантию .

Осуществляем поставки продукции под контролем ВП МО РФ на предприятия военно-промышленного комплекса России , а также работаем в рамках 275 ФЗ с открытием отдельных счетов в уполномоченном банке. Система менеджмента качества компании соответствует требованиям ГОСТ ISO 9001.

Минимальные сроки поставки, гибкие цены, неограниченный ассортимент и индивидуальный подход к клиентам являются основой для выстраивания долгосрочного и эффективного сотрудничества с предприятиями радиоэлектронной промышленности, предприятиями ВПК и научно-исследовательскими институтами России.

С нами вы становитесь еще успешнее!

### Наши контакты:

**Телефон:** +7 812 627 14 35

**Электронная почта:** [sales@st-electron.ru](mailto:sales@st-electron.ru)

**Адрес:** 198099, Санкт-Петербург,  
Промышленная ул, дом № 19, литера Н,  
помещение 100-Н Офис 331