

NBSG72A

2.5V/3.3V SiGe Differential 2 x 2 Crosspoint Switch with Output Level Select

The NBSG72A is a high-bandwidth fully differential 2 X 2 crosspoint switch with Output Level Select (OLS) capabilities. This is a part of the GigaComm™ family of high performance Silicon Germanium products. The device is housed in a low profile 3 X 3 mm 16-pin QFN package.

Differential inputs incorporate internal 50 Ω termination resistors and accept NECL (Negative ECL), PECL (Positive ECL), LVCMOS/LVTTL, CML, or LVDS. The OLS input is used to program the peak-to-peak output amplitude between 0 mV and 800 mV in five discrete steps. The SELECT inputs are single-ended and can be driven with either LVECL or LVCMOS/LVTTL input levels.

Features

- Maximum Input Clock Frequency > 7 GHz Typical
- Maximum Input Data Rate > 7 Gb/s Typical
- 200 ps Typical Propagation Delay (OLS = FLOAT)
- 55/45 ps Typical Rise/Fall Times (OLS = FLOAT)
- Selectable Swing PECL Output with Operating Range:
 $V_{CC} = 2.375 \text{ V to } 3.465 \text{ V}$ with $V_{EE} = 0 \text{ V}$
- Selectable Swing NECL Output with NECL Inputs with Operating Range: $V_{CC} = 0 \text{ V}$ with $V_{EE} = -2.375 \text{ V to } -3.465 \text{ V}$
- Selectable Output Levels (0 mV, 200 mV, 400 mV, 600 mV or 800 mV Peak-to-Peak Output)
- 50 Ω Internal Input Termination Resistors
- Single-Ended LVECL or LVCMOS/LVTTL Select Inputs (SELA, SELB)
- Pb-Free Packages are Available



ON Semiconductor®

<http://onsemi.com>

MARKING DIAGRAM*



QFN-16
MN SUFFIX
CASE 485G

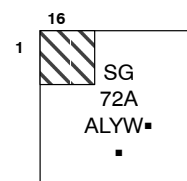

A = Assembly Location
L = Wafer Lot
Y = Year
W = Work Week
▪ = Pb-Free Package
(Note: Microdot may be in either location)

*For additional marking information, refer to Application Note AND8002/D.

ORDERING INFORMATION

See detailed ordering and shipping information in the package dimensions section on page 13 of this data sheet.

NBSG72A

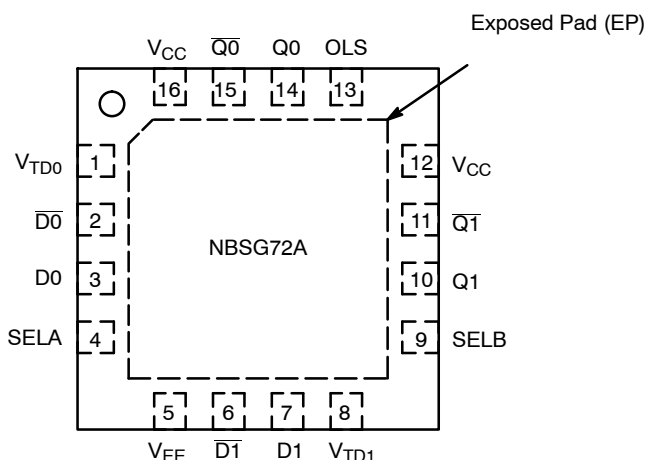

Figure 1. QFN-16 Pinout (Top View)

Table 1. PIN DESCRIPTION

Pin No.	Name	I/O	Description
1	VTD0	-	Common Internal 50 Ω Termination Pin for D0 and $\overline{D0}$ Input. See Table 4. (Note 1)
2	$\overline{D0}$	LVDS, CML, ECL, LVTTTL, LVCMOS Input	Inverted Differential Input 0.
3	D0	LVDS, CML, ECL, LVTTTL, LVCMOS Input	Noninverted Differential Input 0.
4	SELA	LVECL, LVCMOS Input	Select Logic Input A. Internal 75 k Ω Pulldown to V_{EE} .
5	V_{EE}	-	Negative Supply. All V_{EE} Pins must be Externally Connected to Power Supply to Guarantee Proper Operation.
6	$\overline{D1}$	LVDS, CML, ECL, LVTTTL, LVCMOS Input	Inverted Differential Input 1.
7	D1	LVDS, CML, ECL, LVTTTL, LVCMOS Input	Noninverted Differential Input 1.
8	VTD1	-	Common Internal 50 Ω Termination Pin for D1 and $\overline{D1}$ Input. See Table 4. (Note 1)
9	SELB	LVECL, LVCMOS Input	Select Logic Input B. Internal 75 k Ω Pulldown to V_{EE} .
10	Q1	RSECL Output	Noninverted Differential Output.
11	$\overline{Q1}$	RSECL Output	Inverted Differential Output.
12	V_{CC}	-	Positive Supply. All V_{CC} Pins must be Externally Connected to Power Supply to Guarantee Proper Operation.
13	OLS (Note 2)	Input	Input Pin for Output Level Select (OLS) See Table 3.
14	Q0	RSECL Output	Noninverted Differential Output Typically Terminated with 50 Ω Resistor to $V_{TT} = V_{CC} - 2.0$ V.
15	$\overline{Q0}$	RSECL Output	Inverted Differential Output Typically Terminated with 50 Ω Resistor to $V_{TT} = V_{CC} - 2.0$ V.
16	V_{CC}	-	Positive Supply. All V_{CC} Pins must be Externally Connected to Power Supply to Guarantee Proper Operation.
-	EP	-	The Exposed Pad (EP) and the QFN-16 package bottom is thermally connected to the die for improved heat transfer out of package. The exposed pad must be attached to a heat-sinking conduit. The pad is not electrically connected to the die but may be electrically and thermally connected to V_{EE} on the PC board.

1. In the differential configuration when the input termination pins (VTD0, VTD1) are connected to a common termination voltage, and if no signal is applied then the device will be susceptible to self-oscillation.
2. When an output level of 400 mV is desired and $V_{CC} - V_{EE} > 3.0$ V, 2 k Ω resistor should be connected from OLS pin to V_{EE} .

NBSG72A

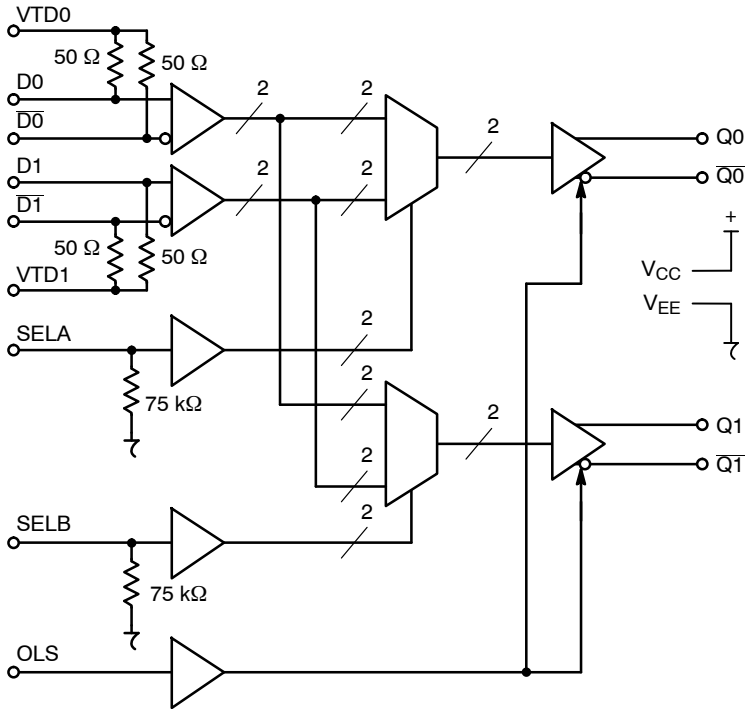

Figure 2. Logic/Block Diagram

Table 2. TRUTH TABLE

SELA	SELB	Q0	Q1
LOW	LOW	D0	D0
HIGH	LOW	D1	D0
LOW	HIGH	D0	D1
HIGH	HIGH	D1	D1

Table 3. OUTPUT LEVEL SELECT (OLS)

OLS	Output Amplitude (V_{OUTPP})	OLS Sensitivity
V_{CC}	800 mV	OLS - 75 mV
$V_{CC} - 0.4 V$	200 mV	OLS \pm 150 mV
$V_{CC} - 0.8 V$	600 mV	OLS \pm 100 mV
$V_{CC} - 1.2 V$	0	OLS \pm 75 mV
V_{EE} (Note 3)	400 mV	OLS \pm 100 mV
FLOAT	600 mV	N/A

3. When an output level of 400 mV is desired and $V_{CC} - V_{EE} > 3.0 V$, a 2 k Ω resistor should be connected from OLS to V_{EE} .

Table 4. INTERFACING OPTIONS

Interfacing Options	Connections
CML	Connect VTD0 and VTD1 to V_{CC}
LVDS	VTD0 and VTD1 Should Be Left Floating.
AC-COUPLED	Bias VTD0 and VTD1 Inputs within Common Mode Range (VIHCMR)
RSECL, PECL, NECL	Standard ECL Termination Techniques
LVC MOS / LVTTTL	The external voltage should be applied to the unused complementary differential input. Nominal voltage is 1.5 V for LVTTTL and $V_{CC}/2$ for LVC MOS Inputs.

NBSG72A

Table 5. ATTRIBUTES

Characteristics	Value
Internal Input Pulldown Resistor (SELA, SELB)	75 kΩ
ESD Protection	Human Body Model Machine Model Charged Device Model
	> 2 kV > 50 V > 1 kV
Moisture Sensitivity (Note 1)	Level 1
Flammability Rating	Oxygen Index: 28 to 34
	UL 94 V-0 @ 0.125 in
Transistor Count	436
Meets or exceeds JEDEC Spec EIA/JESD78 IC Latchup Test	

1. For additional information, see Application Note AND8003/D.

Table 6. MAXIMUM RATINGS

Symbol	Parameter	Condition 1	Condition 2	Rating	Units
V _{CC}	Positive Power Supply	V _{EE} = 0 V		3.6	V
V _{EE}	Negative Power Supply	V _{CC} = 0 V		-3.6	V
V _I	Positive Input Negative Input	V _{EE} = 0 V V _{CC} = 0 V	V _I ≤ V _{CC} V _I ≥ V _{EE}	3.6 -3.6	V V
V _{INPP}	Differential Input Voltage D _X - \overline{D}_X	V _{EE} - V _{CC} ≥ 2.8 V V _{EE} - V _{CC} < 2.8 V		2.8 V _{CC} - V _{EE}	V
I _{out}	Output Current	Continuous Surge		25 50	mA mA
I _{IN}	Input Current Through R _T (50 Ω Resistor)	Static Surge		45 80	mA mA
T _A	Operating Temperature Range			-40 to +85	°C
T _{stg}	Storage Temperature Range			-65 to +150	°C
θ _{JA}	Thermal Resistance (Junction-to-Ambient) (Note 2)	0 lfpm 500 lfpm	QFN-16 QFN-16	42 35	°C/W °C/W
θ _{JC}	Thermal Resistance (Junction-to-Case)	(Note 2)	QFN-16	4	°C/W
T _{sol}	Wave Solder	Pb Pb-Free	< 3 sec @ 260°C < 3 sec @ 260°C	265 265	°C

Stresses exceeding Maximum Ratings may damage the device. Maximum Ratings are stress ratings only. Functional operation above the Recommended Operating Conditions is not implied. Extended exposure to stresses above the Recommended Operating Conditions may affect device reliability.

2. JEDEC standard multilayer board – 1S2P (1 signal, 2 power).

NBSG72A

Table 7. DC CHARACTERISTICS, INPUT WITH PECL OUTPUT $V_{CC} = 2.5\text{ V}$; $V_{EE} = 0\text{ V}$ (Note 3)

Symbol	Characteristic	-40°C			25°C			85°C			Unit
		Min	Typ	Max	Min	Typ	Max	Min	Typ	Max	
I_{EE}	Negative Power Supply Current	40	55	65	40	55	65	40	55	65	mA
V_{OH}	Output HIGH Voltage (Note 4)	1460	1510	1560	1490	1540	1590	1515	1565	1615	mV
V_{OL}	Output LOW Voltage (Note 4)										mV
	(OLS = V_{CC})	555	705	855	595	745	895	625	775	925	
	(OLS = $V_{CC} - 0.4\text{ V}$)	1235	1295	1385	1270	1330	1420	1295	1355	1445	
	(OLS = $V_{CC} - 0.8\text{ V}$, OLS = FLOAT)	775	895	1015	810	930	1050	840	960	1080	
	(OLS = $V_{CC} - 1.2\text{ V}$)	1455	1505	1585	1490	1540	1620	1510	1560	1640	
	(OLS = V_{EE})	1005	1095	1215	1040	1130	1250	1065	1155	1275	
V_{OUTPP}	Output Voltage Amplitude										mV
	(OLS = V_{CC})	670	800		660	795		655	790		
	(OLS = $V_{CC} - 0.4\text{ V}$)	125	215		120	210		120	210		
	(OLS = $V_{CC} - 0.8\text{ V}$, OLS = FLOAT)	510	615		505	610		500	605		
	(OLS = $V_{CC} - 1.2\text{ V}$)	0	5		0	0		0	5		
	(OLS = V_{EE})	325	415		320	410		320	410		
V_{IH}	Input HIGH Voltage (Single-Ended) (Note 6) D0, $\overline{D0}$, D1, $\overline{D1}$, SELA, SELB	$V_{EE} + 1275$	$V_{CC} - 1000^*$	V_{CC}	$V_{EE} + 1275$	$V_{CC} - 1000^*$	V_{CC}	$V_{EE} + 1275$	$V_{CC} - 1000^*$	V_{CC}	mV
V_{IL}	Input LOW Voltage (Single-Ended) (Note 7) D0, $\overline{D0}$, D1, $\overline{D1}$, SELA, SELB	V_{EE}	$V_{CC} - 1400^*$	$V_{IH} - 150$	V_{EE}	$V_{CC} - 1400^*$	$V_{IH} - 150$	V_{EE}	$V_{CC} - 1400^*$	$V_{IH} - 150$	mV
V_{IHCMR}	Input HIGH Voltage Common Mode Range (Differential Configuration) (Note 5)	1.2		2.5	1.2		2.5	1.2		2.5	V
R_{TIN}	Internal Input Termination Resistor	45	50	55	45	50	55	45	50	55	Ω
I_{IH}	Input HIGH Current (@ V_{IH})		35	100		35	100		35	100	μA
I_{IL}	Input LOW Current (@ V_{IL})		20	100		20	100		20	100	μA

NOTE: Device will meet the specifications after thermal equilibrium has been established when mounted in a test socket or printed circuit board with maintained transverse airflow greater than 500 lpm. Electrical parameters are guaranteed only over the declared operating temperature range. Functional operation of the device exceeding these conditions is not implied. Device specification limit values are applied individually under normal operating conditions and not valid simultaneously.

*Typicals used for testing purposes.

3. Input and output parameters vary 1:1 with V_{CC} . V_{EE} can vary +0.125 V to -0.965 V.

4. All loading with 50 Ω to $V_{CC} - 2.0\text{ V}$.

5. V_{IHCMR} min varies 1:1 with V_{EE} , V_{IHCMR} max varies 1:1 with V_{CC} . The V_{IHCMR} range is referenced to the most positive side of the differential input signal.

6. V_{IH} cannot exceed V_{CC} .

7. V_{IL} always $\geq V_{EE}$.

NBSG72A

Table 8. DC CHARACTERISTICS, INPUT WITH PECL OUTPUT $V_{CC} = 3.3\text{ V}$; $V_{EE} = 0\text{ V}$ (Note 8)

Symbol	Characteristic	-40°C			25°C			85°C			Unit
		Min	Typ	Max	Min	Typ	Max	Min	Typ	Max	
I_{EE}	Negative Power Supply Current	40	55	65	40	55	65	40	55	65	mA
V_{OH}	Output HIGH Voltage (Note 9)	2260	2310	2360	2290	2340	2390	2315	2365	2415	mV
V_{OL}	Output LOW Voltage (Note 9)										mV
	(OLS = V_{CC})	1320	1470	1620	1360	1510	1660	1390	1540	1690	
	(OLS = $V_{CC} - 0.4\text{ V}$)	2030	2090	2180	2065	2125	2215	2090	2150	2240	
	(OLS = $V_{CC} - 0.8\text{ V}$, OLS = FLOAT)	1550	1670	1790	1585	1705	1825	1615	1735	1855	
	(OLS = $V_{CC} - 1.2\text{ V}$)	2260	2310	2390	2290	2340	2420	2315	2365	2445	
	** (OLS = V_{EE})	1785	1875	1995	1820	1910	2030	1850	1940	2060	
V_{OUTPP}	Output Amplitude Voltage										mV
	(OLS = V_{CC})	705	815		695	805		690	800		
	(OLS = $V_{CC} - 0.4\text{ V}$)	130	220		125	215		125	215		
	(OLS = $V_{CC} - 0.8\text{ V}$, OLS = FLOAT)	535	640		530	635		525	630		
	(OLS = $V_{CC} - 1.2\text{ V}$)	0	0		0	0		0	0		
	** (OLS = V_{EE})	345	435		340	430		335	425		
V_{IH}	Input HIGH Voltage (Single-Ended) (Note 11) D0, $\overline{D0}$, D1, $\overline{D1}$, SELA, SELB	$V_{EE} + 1275$	$V_{CC} - 1000^*$	V_{CC}	$V_{EE} + 1275$	$V_{CC} - 1000^*$	V_{CC}	$V_{EE} + 1275$	$V_{CC} - 1000^*$	V_{CC}	mV
V_{IL}	Input LOW Voltage (Single-Ended) (Note 12) D0, $\overline{D0}$, D1, $\overline{D1}$, SELA, SELB	$V_{IH} - 2600$	$V_{CC} - 1400^*$	$V_{IH} - 150$	$V_{IH} - 2600$	$V_{CC} - 1400^*$	$V_{IH} - 150$	$V_{IH} - 2600$	$V_{CC} - 1400^*$	$V_{IH} - 150$	mV
V_{IHCMR}	Input HIGH Voltage Common Mode Range (Differential Configuration) (Note 10)	1.2		3.3	1.2		3.3	1.2		3.3	V
R_{TIN}	Internal Input Termination Resistor	45	50	55	45	50	55	45	50	55	Ω
I_{IH}	Input HIGH Current (@ V_{IH})		35	100		35	100		35	100	μA
I_{IL}	Input LOW Current (@ V_{IL})		20	100		20	100		20	100	μA

NOTE: Device will meet the specifications after thermal equilibrium has been established when mounted in a test socket or printed circuit board with maintained transverse airflow greater than 500 lfm. Electrical parameters are guaranteed only over the declared operating temperature range. Functional operation of the device exceeding these conditions is not implied. Device specification limit values are applied individually under normal operating conditions and not valid simultaneously.

*Typicals used for testing purposes.

**When an output level of 400 mV is desired and $V_{CC} - V_{EE} > 3.0\text{ V}$, a 2 k Ω resistor should be connected from OLS to V_{EE} .

8. Input and output parameters vary 1:1 with V_{CC} . V_{EE} can vary +0.925 V to -0.165 V.

9. All loading with 50 Ω to $V_{CC} - 2.0\text{ V}$.

10. V_{IHCMR} min varies 1:1 with V_{EE} , V_{IHCMR} max varies 1:1 with V_{CC} . The V_{IHCMR} range is referenced to the most positive side of the differential input signal.

11. V_{IH} cannot exceed V_{CC} .

12. V_{IL} always $\geq V_{EE}$.

NBSG72A

Table 9. DC CHARACTERISTICS, NECL INPUT WITH NECL OUTPUT $V_{CC} = 0\text{ V}$; $V_{EE} = -3.465\text{ V}$ to -2.375 V (Note 13)

Symbol	Characteristic	-40°C			25°C			85°C			Unit			
		Min	Typ	Max	Min	Typ	Max	Min	Typ	Max				
I_{EE}	Negative Power Supply Current	40	55	65	40	55	65	40	55	65	mA			
V_{OH}	Output HIGH Voltage (Note 14)	-1040	-990	-940	-1010	-960	-910	-985	-935	-885	mV			
V_{OL}	Output LOW Voltage (Note 14) -3.465 V \leq $V_{EE} \leq$ -3.0 V (OLS = V_{CC}) (OLS = $V_{CC} - 0.4\text{ V}$) (OLS = $V_{CC} - 0.8\text{ V}$, OLS = FLOAT) (OLS = $V_{CC} - 1.2\text{ V}$) **(OLS = V_{EE}) -3.0 V < $V_{EE} \leq$ -2.375 V (OLS = V_{CC}) (OLS = $V_{CC} - 0.4\text{ V}$) (OLS = $V_{CC} - 0.8\text{ V}$, OLS = FLOAT) (OLS = $V_{CC} - 1.2\text{ V}$) (OLS = V_{EE})	-1980	-1830	-1680	-1940	-1790	-1640	-1910	-1760	-1610	mV			
		-1270	-1210	-1120	-1235	-1175	-1085	-1210	-1150	-1060				
		-1750	-1630	-1510	-1715	-1595	-1475	-1685	-1565	-1445				
		-1040	-990	-910	-1010	-960	-880	-985	-935	-855				
		-1515	-1425	-1305	-1480	-1390	-1270	-1450	-1360	-1240				
		-1945	-1795	-1645	-1905	-1755	-1605	-1875	-1725	-1575				
		-1265	-1205	-1115	-1230	-1170	-1080	-1205	-1145	-1055				
		-1725	-1605	-1485	-1690	-1570	-1450	-1660	-1540	-1420				
		-1045	-995	-915	-1010	-960	-880	-990	-940	-860				
		-1495	-1405	-1285	-1460	-1370	-1250	-1435	-1345	-1225				
		V_{OUTPP}	Output Voltage Amplitude -3.465 V \leq $V_{EE} \leq$ -3.0 V (OLS = V_{CC}) (OLS = $V_{CC} - 0.4\text{ V}$) (OLS = $V_{CC} - 0.8\text{ V}$, OLS = FLOAT) (OLS = $V_{CC} - 1.2\text{ V}$) **(OLS = V_{EE}) -3.0 V < $V_{EE} \leq$ -2.375 V (OLS = V_{CC}) (OLS = $V_{CC} - 0.4\text{ V}$) (OLS = $V_{CC} - 0.8\text{ V}$, OLS = FLOAT) (OLS = $V_{CC} - 1.2\text{ V}$) (OLS = V_{EE})	705	815		695	805		690		800		mV
				130	220		125	215		125		215		
535	640				530	635		525	630					
0	0				0	0		0	0					
345	435				340	430		335	425					
670	800				660	795		655	790					
125	215				120	210		120	210					
510	615				505	610		500	605					
0	5				0	0		0	5					
325	415				320	410		320	410					
V_{IH}	Input HIGH Voltage (Single-Ended) (Note 16) D0, D0, D1, D1, SELA, SELB			$V_{EE} + 1275$	$V_{CC} - 1000^*$	V_{CC}	$V_{EE} + 1275$	$V_{CC} - 1000^*$	V_{CC}	$V_{EE} + 1275$	$V_{CC} - 1000^*$	V_{CC}	mV	
				V_{IH}^- 2600	V_{CC}^- 1400*	V_{IH}^- 150	V_{IH}^- 2600	V_{CC}^- 1400*	V_{IH}^- 150	V_{IH}^- 2600	V_{CC}^- 1400*	V_{IH}^- 150	mV	
V_{IHCMR}	Input HIGH Voltage Common Mode Range (Differential Configuration) (Note 15)	$V_{EE} + 1.2$		0.0	$V_{EE} + 1.2$		0.0	$V_{EE} + 1.2$		0.0	V			
R_{TIN}	Internal Input Termination Resistor	45	50	55	45	50	55	45	50	55	Ω			
I_{IH}	Input HIGH Current (@ V_{IH})		35	100		35	100		35	100	μA			
I_{IL}	Input LOW Current (@ V_{IL})		20	100		20	100		20	100	μA			
I_{OLS}	OLS Input Current (See Figure 9) (OLS = V_{CC}) (OLS = $V_{CC} - 0.4\text{ V}$) (OLS = $V_{CC} - 0.8\text{ V}$, OLS = FLOAT) (OLS = $V_{CC} - 1.2\text{ V}$) -3.0 V < $V_{EE} \leq$ -2.375 V (OLS = V_{EE}) -3.465 V \leq $V_{EE} \leq$ -3.0 V *(OLS = V_{EE})		300	900		300	900		300	900	μA			
			100	300		100	300		100	300				
			5	100		5	100		5	100				
		-300	-100		-300	-100		-300	-100					
		-1000	-400		-1000	-400		-1000	-400					
		-1500	-600		-1500	-600		-1500	-600					

NOTE: Device will meet the specifications after thermal equilibrium has been established when mounted in a test socket or printed circuit board with maintained transverse airflow greater than 500 lfm. Electrical parameters are guaranteed only over the declared operating temperature range. Functional operation of the device exceeding these conditions is not implied. Device specification limit values are applied individually under normal operating conditions and not valid simultaneously.

*Typicals used for testing purposes.

**When an output level of 400 mV is desired and $V_{CC} - V_{EE} > 3.0\text{ V}$, a 2 k Ω resistor should be connected from OLS to V_{EE} .

13. Input and output parameters vary 1:1 with V_{CC} .

14. All loading with 50 Ω to $V_{CC} - 2.0\text{ V}$.

15. V_{IHCMR} min varies 1:1 with V_{EE} , V_{IHCMR} max varies 1:1 with V_{CC} . The V_{IHCMR} range is referenced to the most positive side of the differential input signal.

16. V_{IH} cannot exceed V_{CC} .

17. V_{IL} always $\geq V_{EE}$.

NBSG72A

Table 10. AC CHARACTERISTICS $V_{CC} = 0\text{ V}$; $V_{EE} = -3.465\text{ V to }-2.375\text{ V}$ or $V_{CC} = 2.375\text{ V to }3.465\text{ V}$; $V_{EE} = 0\text{ V}$ (Note 18)

Symbol	Characteristic	-40°C			25°C			85°C			Unit	
		Min	Typ	Max	Min	Typ	Max	Min	Typ	Max		
V_{OUTPP}	Output Voltage Amplitude (Note 18) $f_{in} < 5\text{ GHz}$ $f_{in} \leq 7\text{ GHz}$	400	590		450	590		440	590		mV	
		200	250		180	250		130	250			
t_{PLH}	Propagation Delay to Output Differential D0, D1 → Q0, Q1 SELA, SELB → Q0, Q1	170	205	255	170	205	255	170	210	260	ps	
		190	265	350	190	265	350	190	265	350		
t_{PHL}	Propagation Delay to Output Differential D0, D1 → Q0, Q1 SELA, SELB → Q0, Q1	170	205	255	170	205	255	170	210	260	ps	
		150	215	270	150	215	270	150	215	270		
t_{SKEW}	Duty Cycle Skew (Note 19) Within-Device Skew Device-to-Device Skew		5.0	25		5.0	25		5.0	25	ps	
			5.0	25		5.0	25		5.0	25		
			15	50		15	50		15	50		
t_{JITTER}	RMS Random Clock Jitter (Note 20) $\leq 1\text{ GHz}$ OLS = V_{CC} $\leq 5\text{ GHz}$ OLS = V_{CC} $\leq 6.5\text{ GHz}$ OLS = V_{CC} $\leq 1\text{ GHz}$ OLS = $V_{CC} - 400\text{ mV}$ $\leq 5\text{ GHz}$ OLS = $V_{CC} - 400\text{ mV}$ $\leq 6.5\text{ GHz}$ OLS = $V_{CC} - 400\text{ mV}$ $\leq 1\text{ GHz}$ OLS = $V_{CC} - 800\text{ mV}$ $\leq 5\text{ GHz}$ OLS = $V_{CC} - 800\text{ mV}$ $\leq 6.5\text{ GHz}$ OLS = $V_{CC} - 800\text{ mV}$ $\leq 1\text{ GHz}$ OLS = V_{EE} $\leq 5\text{ GHz}$ OLS = V_{EE} $\leq 6.5\text{ GHz}$ OLS = V_{EE} Peak-to-Peak Data Dependent Jitter (Note 21) $f_{in} \leq 7\text{ Gb/s}$		0.16	0.3		0.17	0.3		0.18	0.4	ps	
			0.14	0.4		0.16	0.4		0.19	0.4		
			0.21	0.5		0.31	0.7		0.44	0.9		
			0.23	0.4		0.23	0.4		0.25	0.4		
			0.18	0.5		0.19	0.5		0.23	0.5		
			0.2	0.5		0.25	0.6		0.32	0.7		
			0.17	0.3		0.18	0.3		0.19	0.3		
			0.14	0.4		0.16	0.3		0.2	0.3		
			0.2	0.5		0.27	0.7		0.38	0.9		
			0.18	0.3		0.19	0.3		0.2	0.3		
			0.16	0.6		0.17	0.4		0.2	0.4		
			0.18	0.5		0.24	0.6		0.34	0.8		
V_{INPP}	Input Voltage Swing/Sensitivity (Differential Configuration) (Note 22)	75		2600	75		2600	75		2600	mV	
t_r t_f	Output Rise/Fall Times (Q0, Q1) (20% – 80%) @ 1 GHz	t_r t_f	40 30	55 45	70 55	40 30	55 45	70 55	40 30	55 45	70 55	ps

NOTE: Device will meet the specifications after thermal equilibrium has been established when mounted in a test socket or printed circuit board with maintained transverse airflow greater than 500 lfm. Electrical parameters are guaranteed only over the declared operating temperature range. Functional operation of the device exceeding these conditions is not implied. Device specification limit values are applied individually under normal operating conditions and not valid simultaneously.

18. Measured using a 75 mV source, 50% duty cycle clock source. All loading with 50 Ω to $V_{CC} - 2.0\text{ V}$. OLS = FLOAT. Input edge rates 40 ps (20% – 80%).

19. $t_{SKEW} = |t_{PLH} - t_{PHL}|$ for a nominal 50% differential clock input waveform.

20. Additive RMS jitter with 50% Duty Cycle clock signal.

21. Additive Peak-to-Peak data dependent jitter with NRZ PRBS $2^{31}-1$ data at 7 Gb/s.

22. Input Voltage Swing is a single-ended measurement operating in differential mode. V_{INPP} (max) cannot exceed $V_{CC} - V_{EE}$.

NBSG72A

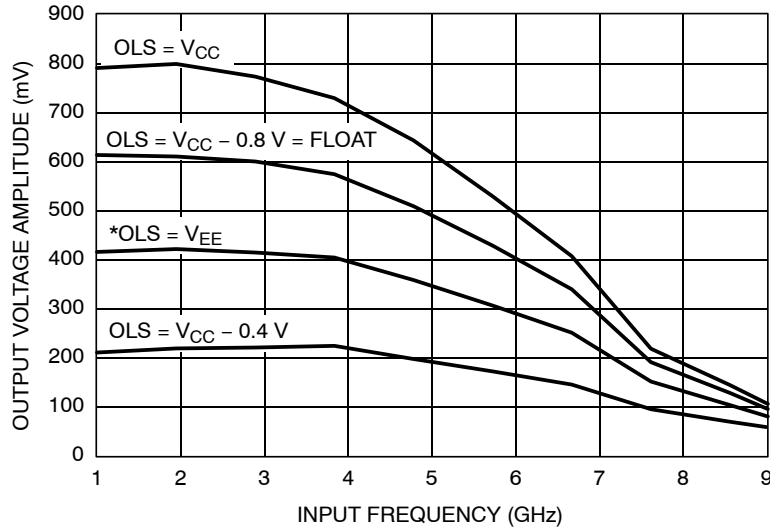

Figure 3. Output Voltage Amplitude (V_{OUTPP}) vs. Input Clock Frequency (f_{IN}) @ Ambient Temperature (Typical)

*When an output level of 400 mV is desired and $V_{CC} - V_{EE} > 3.0$ V, a 2 k Ω resistor should be connected from OLS to V_{EE} .

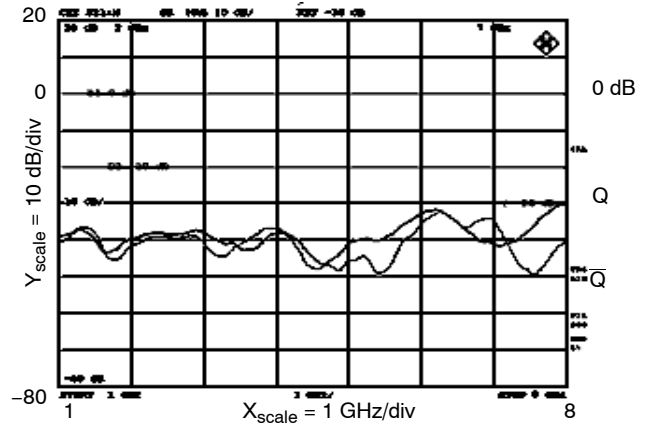
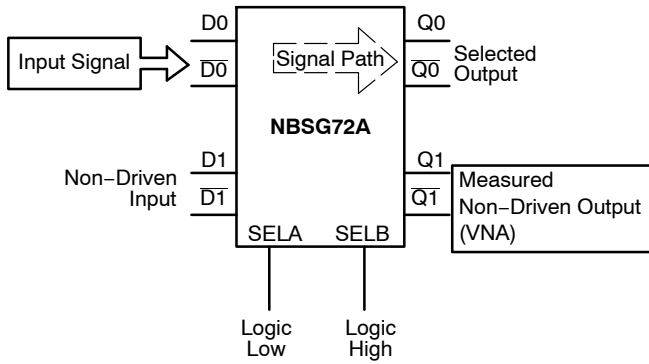

Figure 4. Channel-to-Channel Crosstalk Isolation at Ambient Temperature (D0 to Q0 Signal Path Selected; SelA = Low, SelB = High)

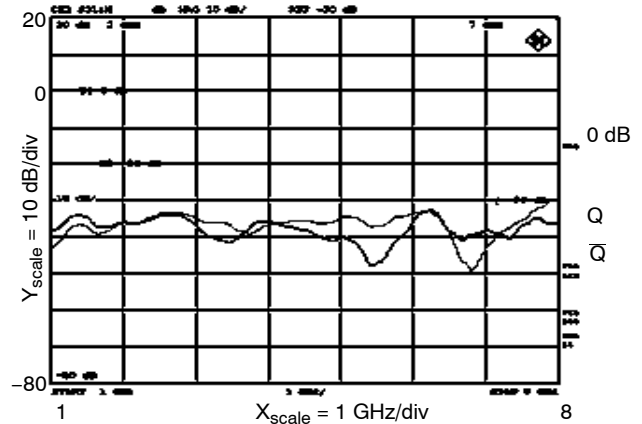
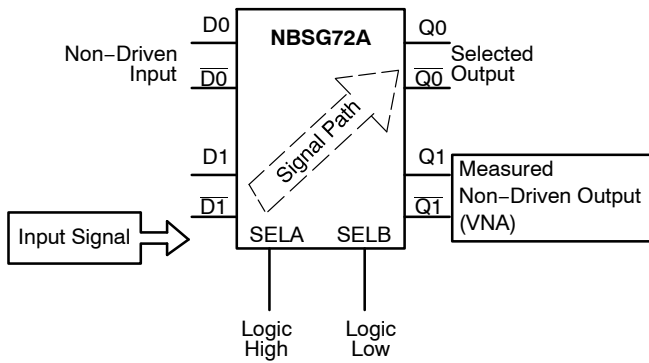

Figure 5. Channel-to-Channel Crosstalk Isolation at Ambient Temperature (D1 to Q0 Signal Path Selected; SelA = High, SelB = Low)

NBSG72A

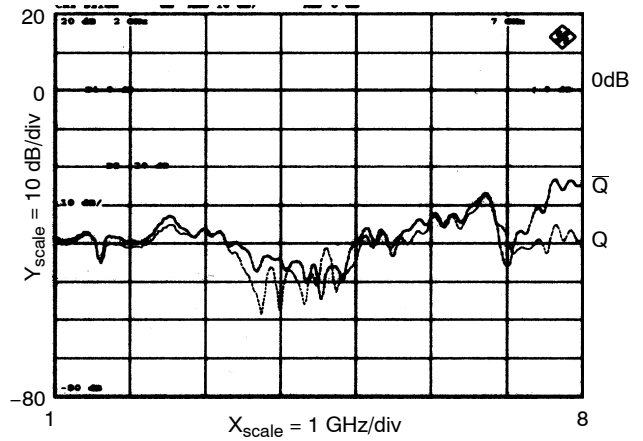
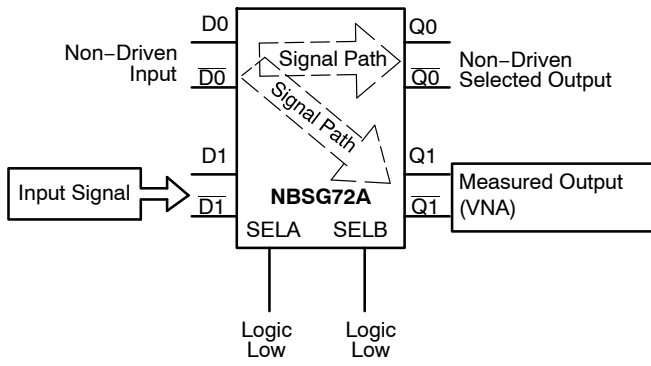

Figure 6. Channel-to-Channel Crosstalk Isolation at Ambient Temperature (D0 to Q0 and Q1 Signal Path Selected; SelA = Low, SelB = Low)

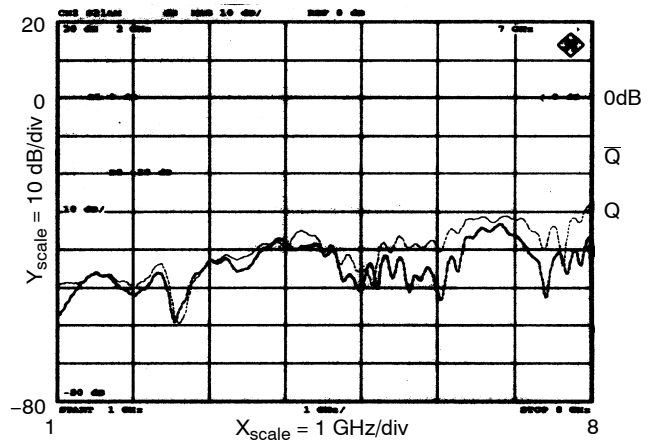
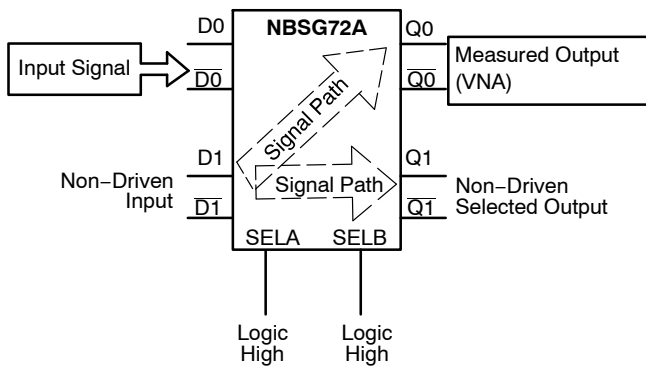
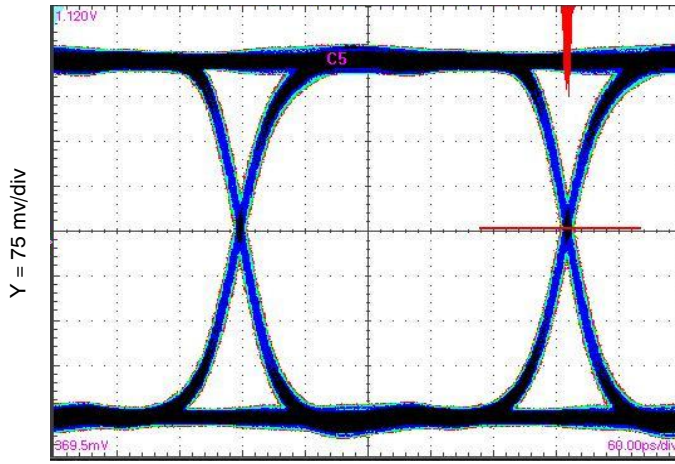

Figure 7. Channel-to-Channel Crosstalk Isolation at Ambient Temperature (D1 to Q0 and Q1 Signal Path Selected; SelA = High, SelB = High)

NBSG72A



Total System Jitter = 17.2 ps
 Input Generator Jitter = 10 ps
 Device Jitter = 6.8 ps

Figure 8. Eye Diagram at 3.2 Gb/s
 ($V_{CC} - V_{EE} = 3.3$ V, OLS = FLOAT @ 25°C with input pattern of $2^{31}-1$ PRBS, 5000 Waveforms)

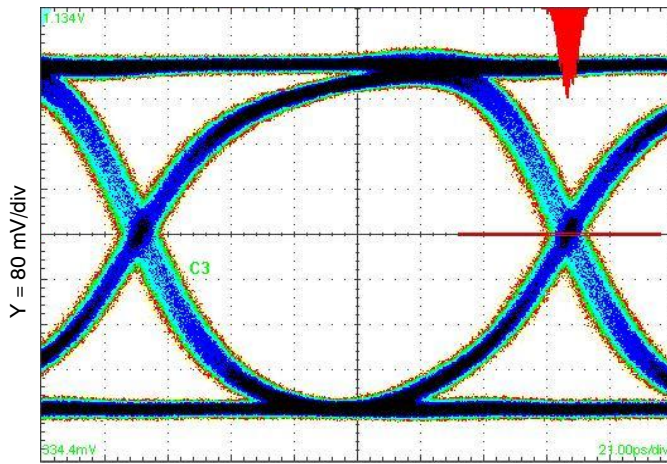

Total System Jitter = 17.2 ps
 Input Generator Jitter = 10 ps
 Device Jitter = 7.2 ps

Figure 9. Eye Diagram at 7 Gb/s/s
 ($V_{CC} - V_{EE} = 3.3$ V, OLS = FLOAT @ 25°C with input pattern of $2^{31}-1$ PRBS, 5000 Waveforms)

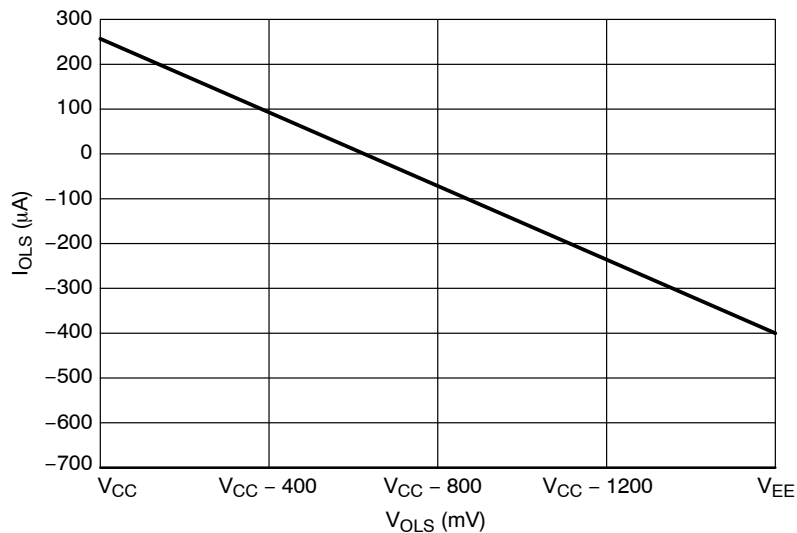

Figure 10. Typical OLS Input Current vs. OLS Input Voltage
 ($V_{CC} - V_{EE} = 3.3$ V @ 25°C)

NBSG72A

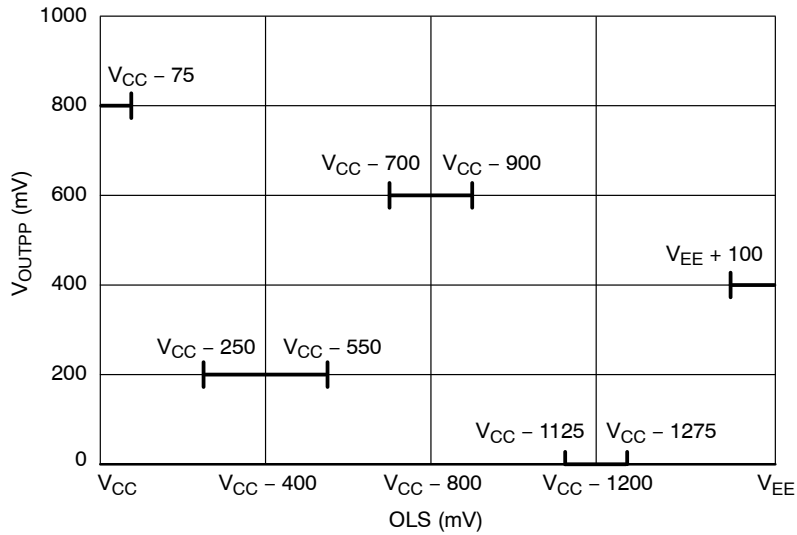

Figure 11. OLS Operating Area

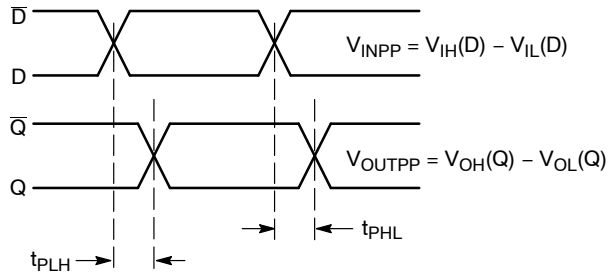

Figure 12. AC Reference Measurement

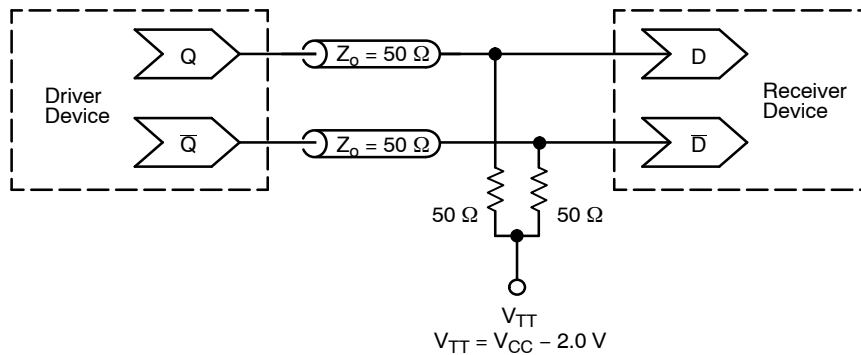

Figure 13. Typical Termination for Output Driver and Device Evaluation
(See Application Note AND8020/D – Termination of ECL Logic Devices.)

NBSG72A

ORDERING INFORMATION

Device	Package	Shipping†
NBSG72AMN	QFN-16	123 Units / Rail
NBSG72AMNG	QFN-16 (Pb-Free)	123 Units / Rail
NBSG72AMNR2	QFN-16	3000 / Tape & Reel
NBSG72AMNR2G	QFN-16 (Pb-Free)	3000 / Tape & Reel

Board	Description
NBSG72AMNEVB	NBSG72AMN Evaluation Board

†For information on tape and reel specifications, including part orientation and tape sizes, please refer to our Tape and Reel Packaging Specifications Brochure, BRD8011/D.

Resource Reference of Application Notes

- AN1405/D** - ECL Clock Distribution Techniques
- AN1406/D** - Designing with PECL (ECL at +5.0 V)
- AN1503/D** - ECLinPS™ I/O SPICE Modeling Kit
- AN1504/D** - Metastability and the ECLinPS Family
- AN1568/D** - Interfacing Between LVDS and ECL
- AN1672/D** - The ECL Translator Guide
- AND8001/D** - Odd Number Counters Design
- AND8002/D** - Marking and Date Codes
- AND8020/D** - Termination of ECL Logic Devices
- AND8066/D** - Interfacing with ECLinPS
- AND8090/D** - AC Characteristics of ECL Devices

NBSG72A

PACKAGE DIMENSIONS

16 PIN QFN
CASE 485G-01
ISSUE C

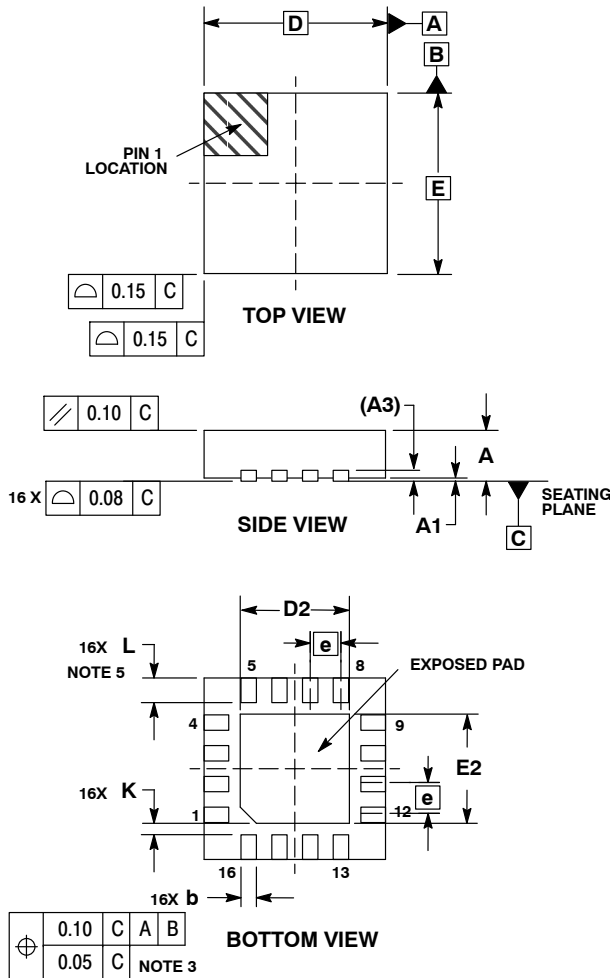

NOTES:

1. DIMENSIONING AND TOLERANCING PER ASME Y14.5M, 1994.
2. CONTROLLING DIMENSION: MILLIMETERS.
3. DIMENSION b APPLIES TO PLATED TERMINAL AND IS MEASURED BETWEEN 0.25 AND 0.30 MM FROM TERMINAL.
4. COPLANARITY APPLIES TO THE EXPOSED PAD AS WELL AS THE TERMINALS.
5. L_{max} CONDITION CAN NOT VIOLATE 0.2 MM MINIMUM SPACING BETWEEN LEAD TIP AND FLAG

DIM	MILLIMETERS	
	MIN	MAX
A	0.80	1.00
A1	0.00	0.05
A3	0.20 REF	
b	0.18	0.30
D	3.00 BSC	
D2	1.65	1.85
E	3.00 BSC	
E2	1.65	1.85
e	0.50 BSC	
K	0.18 TYP	
L	0.30	0.50

GigaComm is a trademark of Semiconductor Components Industries, LLC.

ON Semiconductor and are registered trademarks of Semiconductor Components Industries, LLC (SCILLC). SCILLC reserves the right to make changes without further notice to any products herein. SCILLC makes no warranty, representation or guarantee regarding the suitability of its products for any particular purpose, nor does SCILLC assume any liability arising out of the application or use of any product or circuit, and specifically disclaims any and all liability, including without limitation special, consequential or incidental damages. "Typical" parameters which may be provided in SCILLC data sheets and/or specifications can and do vary in different applications and actual performance may vary over time. All operating parameters, including "Typicals" must be validated for each customer application by customer's technical experts. SCILLC does not convey any license under its patent rights nor the rights of others. SCILLC products are not designed, intended, or authorized for use as components in systems intended for surgical implant into the body, or other applications intended to support or sustain life, or for any other application in which the failure of the SCILLC product could create a situation where personal injury or death may occur. Should Buyer purchase or use SCILLC products for any such unintended or unauthorized application, Buyer shall indemnify and hold SCILLC and its officers, employees, subsidiaries, affiliates, and distributors harmless against all claims, costs, damages, and expenses, and reasonable attorney fees arising out of, directly or indirectly, any claim of personal injury or death associated with such unintended or unauthorized use, even if such claim alleges that SCILLC was negligent regarding the design or manufacture of the part. SCILLC is an Equal Opportunity/Affirmative Action Employer. This literature is subject to all applicable copyright laws and is not for resale in any manner.

PUBLICATION ORDERING INFORMATION

LITERATURE FULFILLMENT:
Literature Distribution Center for ON Semiconductor
P.O. Box 5163, Denver, Colorado 80217 USA
Phone: 303-675-2175 or 800-344-3860 Toll Free USA/Canada
Fax: 303-675-2176 or 800-344-3867 Toll Free USA/Canada
Email: orderlit@onsemi.com

N. American Technical Support: 800-282-9855 Toll Free USA/Canada
Europe, Middle East and Africa Technical Support:
Phone: 421 33 790 2910
Japan Customer Focus Center
Phone: 81-3-5773-3850

ON Semiconductor Website: www.onsemi.com
Order Literature: <http://www.onsemi.com/orderlit>
For additional information, please contact your local Sales Representative



Стандарт Электрон Связь

Мы молодая и активно развивающаяся компания в области поставок электронных компонентов. Мы поставляем электронные компоненты отечественного и импортного производства напрямую от производителей и с крупнейших складов мира.

Благодаря сотрудничеству с мировыми поставщиками мы осуществляем комплексные и плановые поставки широчайшего спектра электронных компонентов.

Собственная эффективная логистика и склад в обеспечивает надежную поставку продукции в точно указанные сроки по всей России.

Мы осуществляем техническую поддержку нашим клиентам и предпродажную проверку качества продукции. На все поставляемые продукты мы предоставляем гарантию .

Осуществляем поставки продукции под контролем ВП МО РФ на предприятия военно-промышленного комплекса России , а также работаем в рамках 275 ФЗ с открытием отдельных счетов в уполномоченном банке. Система менеджмента качества компании соответствует требованиям ГОСТ ISO 9001.

Минимальные сроки поставки, гибкие цены, неограниченный ассортимент и индивидуальный подход к клиентам являются основой для выстраивания долгосрочного и эффективного сотрудничества с предприятиями радиоэлектронной промышленности, предприятиями ВПК и научно-исследовательскими институтами России.

С нами вы становитесь еще успешнее!

Наши контакты:

Телефон: +7 812 627 14 35

Электронная почта: sales@st-electron.ru

Адрес: 198099, Санкт-Петербург,
Промышленная ул, дом № 19, литера Н,
помещение 100-Н Офис 331