

*i*Coupler ADuM3190 Isolated Error Amplifier Evaluation Board

FEATURES

Isolated Error Amplifier

Stable Over Time and Temperature

0.5% initial accuracy

1% accuracy over the full temp range

For Type II or Type III compensation networks

Reference voltage 1.225V

Low power operation: <7 mA total

Wide Supply Voltage Range

V_{DD1} - 3V to 20V

V_{DD2} - 3V to 20V

Bandwidth - 400kHz

Isolation Voltage

2.5kVrms

Wide temperature range:

-40°C to 125°C ambient operation

150°C maximum junction temperature

GENERAL DESCRIPTION

The EVAL-ADuM3190EBZ supports the ADuM3190 isolated error amplifier based on Analog Devices, Inc. *i*Coupler® technology. The ADuM3190 is ideal for linear feedback power supplies with primary side controllers enabling improvements in transient response, power density and stability as compared to commonly used optocoupler and shunt regulator solutions. Included in the ADuM3190 is a wide band operational amplifier which can be used to set up a variety of commonly used power supply loop compensation techniques. The ADuM3190 is fast enough to allow a feedback loop to react to fast transient conditions and over current conditions. Also included is a high accuracy 1.225V reference to compare with the supply output set point.

EVALUATION BOARD

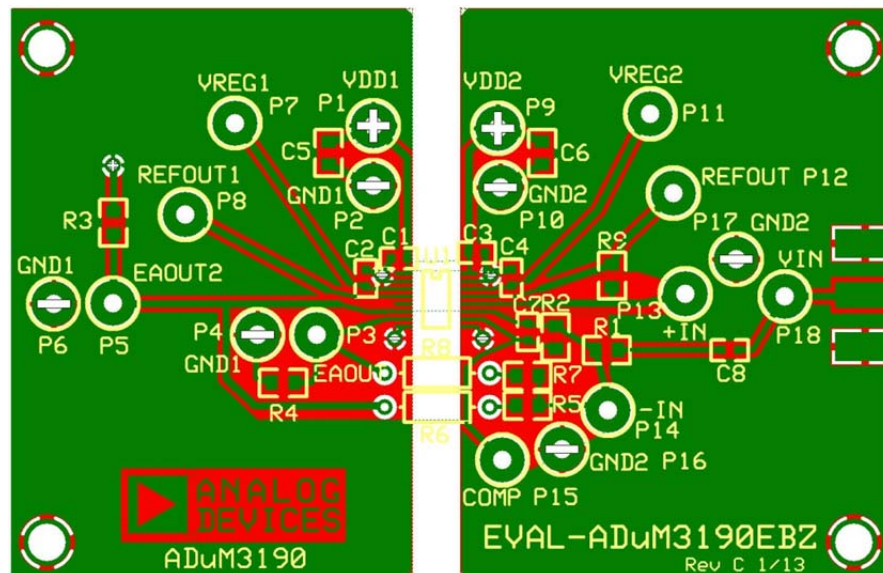

Figure 1: EVAL-ADuM3190EBZ (add photo- available in about 2 weeks)

TABLE OF CONTENTS

Features	1	right side Power Connections	3
General Description.....	1	ACCuracy test Connections	3
Evaluation Board.....	1	Schematic	4
Revision History.....	2	Evaluation Board Layout	5
ADuM3190 isolated error amplifier	3	Ordering Information	6
EVAL-ADuM3190EBZ schematic	3	Bill of Materials	6
left side Power Connections	3	ESD Caution.....	6

REVISION HISTORY**9/10—Revision 0: Initial Version**

ADUM3190 ISOLATED ERROR AMPLIFIER

The EVAL-ADuM3190EBZ board, shown in Figure 1, can be used to evaluate the performance and datasheet specifications of the ADuM3190. Figure 2 shows the schematic of the EVAL-ADuM3190EBZ circuit which can be used to test the accuracy of the ADuM3190 and perform other tests. The EVAL-ADuM3190EBZ is a 4-layer PC Board, complete with ground and power layers as shown in the Evaluation Board Layout section.

EVAL-ADUM3190EBZ SCHEMATIC

Figure 2 is the ADuM3190 schematic of the EVAL-ADuM3190EBZ evaluation board. U1 is the ADuM3190 in the center of the board and Pin 1 is the top-left pad with respect to the notch in the silkscreen's package outline. C1, C2, C3 and C4 are ceramic 0603 1 μ F bypass capacitors required for proper bypassing of the ADuM3190 internal 3V regulators on both sides of part. 10 μ F 0603 ceramic capacitors are added to the VDD1 & VDD2 connections to provide additional bypassing to the board in case long wires are used from power supplies to the evaluation board.

Test point connectors are provided for most of the important connections to pins of the ADuM3190. The following sections describe connections to make to power the EVAL-ADuM3190EBZ and make performance tests.

LEFT SIDE POWER CONNECTIONS

Connect the Left-side external power supply (+3V to 20V) to P1 (labeled "VDD2") and its return to P2 (labeled "GND2").

RIGHT SIDE POWER CONNECTIONS

Connect the Right Side external power supply (+3V to 20V) to P9 (labeled "VDD2") and its return to P10 (labeled "GND2").

ACCURACY TEST CONNECTIONS

Figure 2 EVAL-ADuM3190EBZ Schematic has a blue line outlining the EAOUT accuracy circuit. The capacitor C7 2.2nF together with R8 680 ohm and R7 0 ohm resistors form an integrator circuit to close the loop from the "-IN" input to the "EAOUT" output. A 1% accurate internal reference voltage of 1.225V at "REFOUT" is connected to the non-inverting Op Amp input "+IN" through a 0 ohm resistor R9, providing the reference for the Accuracy Test Circuit. See Figure 3 ADuM3190 Block Diagram or the ADuM3190 datasheet for more information about the operation of the ADuM3190.

Note, as stated in Figure 2, "add a wire between GND1 and GND2 for EAOUT and EAOUT2 accuracy tests". This connection is needed since the accuracy tests connect a 680 ohm resistor across the isolation barrier and creates a current path between the two isolated areas, so a ground return is needed for the accuracy tests. The accuracy of the EAOUT output will be within +/-1% of the reference voltage specified value of 1.225V. Next, the EAOUT2 accuracy test can be performed by removing the R7 0 ohm resistor and placing a 0 ohm resistor at R5, completing the EAOUT2 circuit. Since the EAOUT2 circuit has a high gain and uses the same internal reference voltage to connect to the "-IN" input of the Op Amp, the accuracy of the EAOUT2 output will also be within +/-1% of the reference voltage specified value of 1.225V.

For tests other than the accuracy tests, the 680 ohm resistor connections should be made open by removing R5 and R7 0 ohm resistors, and the external wire connection made between GND1 and GND2 should be removed. Other tests such as datasheet specifications for the Op Amp, Reference, UVLO, Output Characteristics or Power Supply could then be performed.

iCoupler ADuM3190 Isolated Error Amplifier Evaluation Board

SCHEMATIC

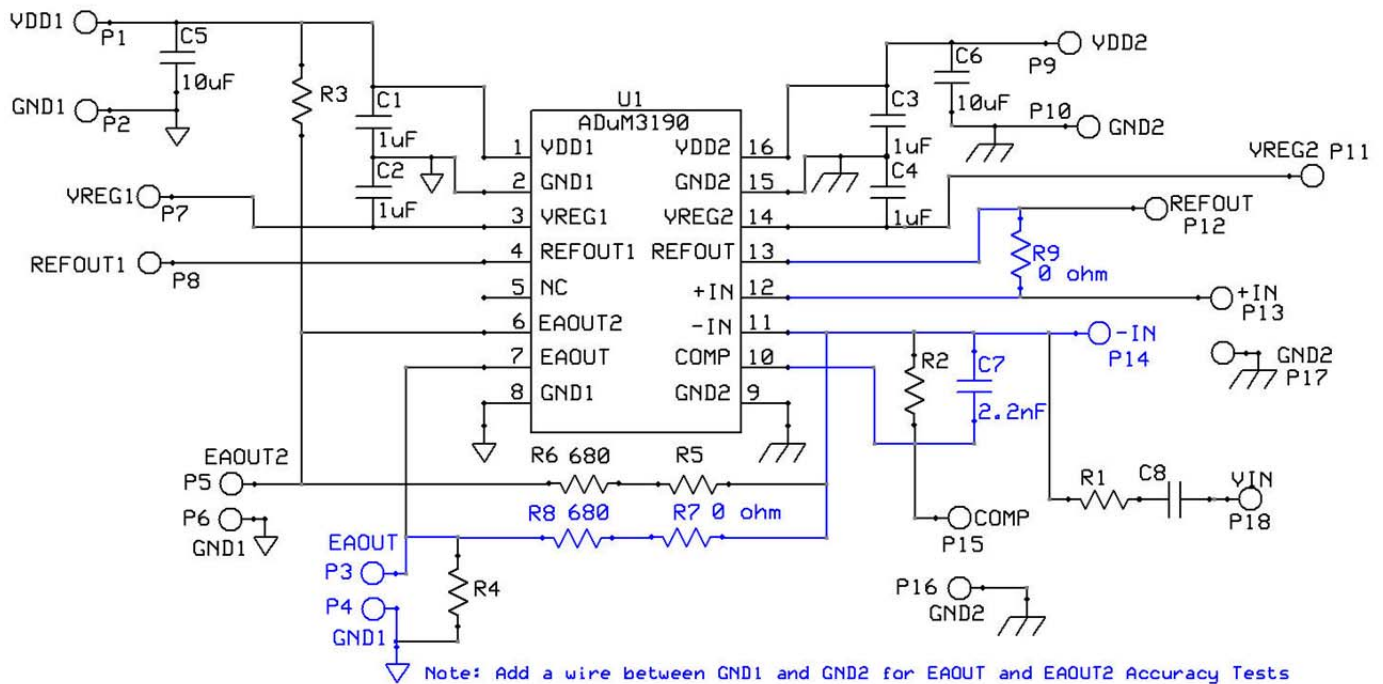

Figure 2. EVAL-ADuM3190EBZ Schematic

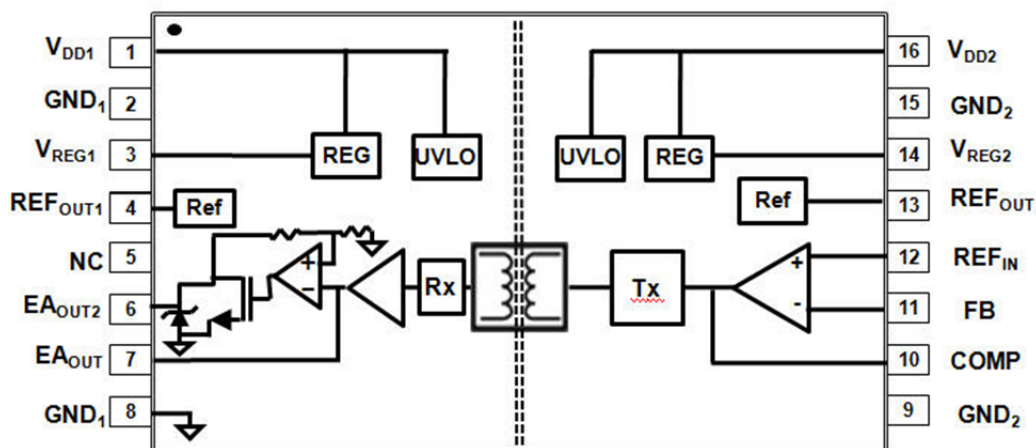

Figure 3. ADuM3190 Block Diagram

EVALUATION BOARD LAYOUT

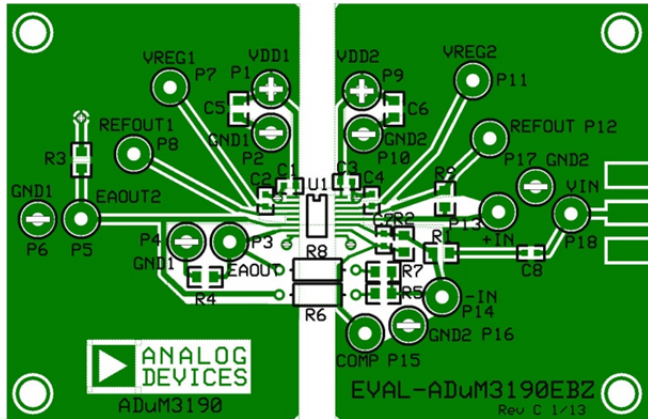

Figure 4. Top Layer: Power Fill

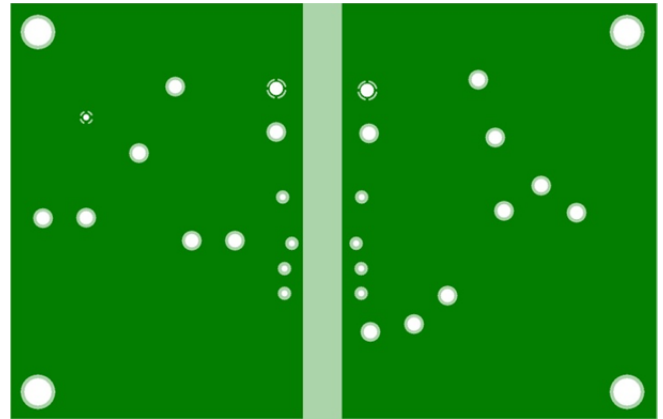

Figure 6. Layer 3: Power Plane

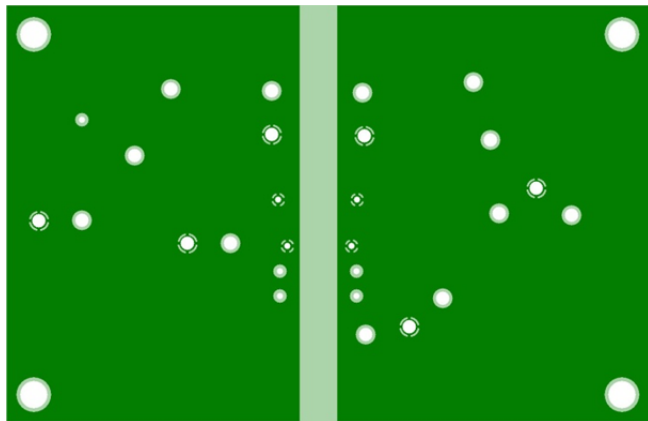

Figure 5. Layer 2: Ground Plane

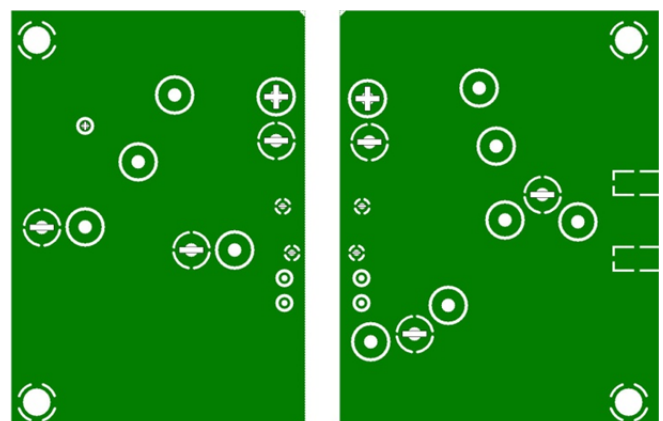

Figure 7. Bottom Layer: Ground Fill

ORDERING INFORMATION**BILL OF MATERIALS**

Table 1.

Qty	Reference Designator	Description	Supplier/Part Number
5	P2, P4, P6, P10, P16, P17	TP-104 series test point, black	Components Corp./TP-104-01-00
5	P1, P3, P5, P9, P13, P14, P15	TP-104 series test point, red	Components Corp./TP-104-01-02
2	U1	ADuM3190	Analog Devices, Inc.
4	C1, C2, C3, C4	Capacitor ceramic, X7R, SMD, 0603, 1 μ F, 20%, 16 V	
3	C5, C6	Capacitor ceramic, X7R, SMD, 0805, 10 μ F, 20%, 25 V	
4	C7	Capacitor ceramic, X7R, SMD, 0603, 2.2 nF, 20% 16 V	
4	C8	Capacitor ceramic, X7R, SMD, 0603, 10 μ F, 20% 6.3 V	
2	R7, R9	RES chip, SMD 0805, 0 Ω , 1/8 W, 1%	
2	R6, R8	RESTHROUGHOLE, 680 Ω , 1/4 W, 5%	

ESD CAUTION**ESD (electrostatic discharge) sensitive device.**

Charged devices and circuit boards can discharge without detection. Although this product features patented or proprietary protection circuitry, damage may occur on devices subjected to high energy ESD. Therefore, proper ESD precautions should be taken to avoid performance degradation or loss of functionality.

Evaluation boards are only intended for device evaluation and not for production purposes. Evaluation boards are supplied "as is" and without warranties of any kind, express, implied, or statutory including, but not limited to, any implied warranty of merchantability or fitness for a particular purpose. No license is granted by implication or otherwise under any patents or other intellectual property by application or use of evaluation boards. Information furnished by Analog Devices is believed to be accurate and reliable. However, no responsibility is assumed by Analog Devices for its use, nor for any infringements of patents or other rights of third parties that may result from its use. Analog Devices reserves the right to change devices or specifications at any time without notice. Trademarks and registered trademarks are the property of their respective owners. Evaluation boards are not authorized to be used in life support devices or systems.



Стандарт Электрон Связь

Мы молодая и активно развивающаяся компания в области поставок электронных компонентов. Мы поставляем электронные компоненты отечественного и импортного производства напрямую от производителей и с крупнейших складов мира.

Благодаря сотрудничеству с мировыми поставщиками мы осуществляем комплексные и плановые поставки широчайшего спектра электронных компонентов.

Собственная эффективная логистика и склад в обеспечивает надежную поставку продукции в точно указанные сроки по всей России.

Мы осуществляем техническую поддержку нашим клиентам и предпродажную проверку качества продукции. На все поставляемые продукты мы предоставляем гарантию .

Осуществляем поставки продукции под контролем ВП МО РФ на предприятия военно-промышленного комплекса России , а также работаем в рамках 275 ФЗ с открытием отдельных счетов в уполномоченном банке. Система менеджмента качества компании соответствует требованиям ГОСТ ISO 9001.

Минимальные сроки поставки, гибкие цены, неограниченный ассортимент и индивидуальный подход к клиентам являются основой для выстраивания долгосрочного и эффективного сотрудничества с предприятиями радиоэлектронной промышленности, предприятиями ВПК и научно-исследовательскими институтами России.

С нами вы становитесь еще успешнее!

Наши контакты:

Телефон: +7 812 627 14 35

Электронная почта: sales@st-electron.ru

Адрес: 198099, Санкт-Петербург,
Промышленная ул, дом № 19, литера Н,
помещение 100-Н Офис 331