



QPL7210

2.4GHz Wi-Fi LNA+BAW Receive Module

Product Overview

The QPL7210 provides a complete integrated receive solution in a single placement front end module (FEM) for Wi-Fi 802.11a/n/ac/ax systems. The full integration minimizes layout area in the customer's application and greatly reduces the design complexity and the number of external components. Performance is focused on best in class Rx immunity from interferes and out of band blockers while achieving leading edge Rx sensitivity accros all Wi-Fi channels. The QPL7210 integrates a 2.4GHz low noise amplifier (LNA) with power, an LNA bypass, and high selectivity receive BAW filter for wireless coexistence. The QPL7210 integrated filtering also includes 2nd and 3rd harmonics and 5GHz rejection for dual-band dual-concurrent operation. The device is provided in a 3.0mm x 3.5mm x 1mm max laminate package. This module meets or exceeds the RF front end needs of IEEE 802.11b/g/n/ac/ax Wi-Fi RF systems.

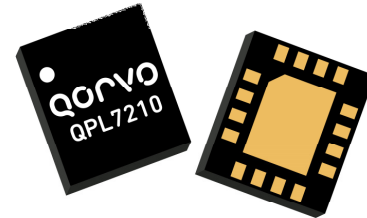

16-pin 3.0mm x 3.5mm x 1mm leadless SMT Package

Key Features

- Fully integrated LNA module including highly selective BAW filter for coexistence attenuation over operating conditions
- Optimized for 3.3 - 5V Operation
- 13.5 dB Rx Gain
- 2.5 dB Noise Figure
- +30dBm OIP3, 3,3V
- +3.5dBm IP1dB, 3.3V

Functional Block Diagram

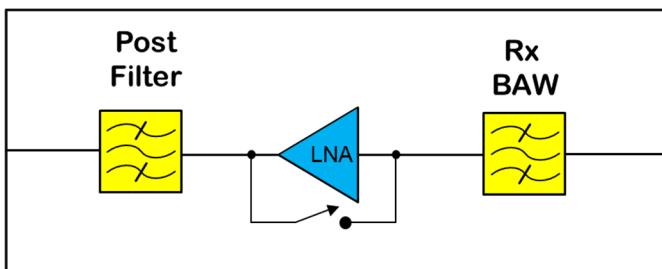

Top View

Applications

- IEEE 802.11b/g/n/ac/ax WLAN Applications
- Wi-Fi Consumer Premise Equipment
- Access Points
- Wireless Routers
- Residential Gateways
- Internet of Things

Ordering Information

Part Number	Description
QPL7210SB	Sample bag with 5 pieces
QPL7210SQ	Sample bag with 25 pieces
QPL7210SR	7" Reel with 100 pieces
QPL7210TR7	7" Reel with 2500 pieces
QPL7210EVB-01	Assembled Evaluation Board

Absolute Maximum Ratings

Parameter	Rating	Unit
Storage Temperature	-40 to 125	°C
Case Temperature, Survival	-40 to 100	°C
DC Supply Voltage (No RF Applied)	-0.5 to +6.0	VDC
DC Supply Current	0.3	A
LNA On Maximum RX input power (No damage), 50Ω, Vcc=5V, T = 25°C	+24	dBm
Bypass Mode Maximum RX input power (No damage), 50Ω, Vcc=5V, T = 25°C	+24	dBm
Moisture Sensitivity	MSL3	

Operation of this device outside the parameter ranges given above may cause permanent damage.

Recommended Operating Conditions

Parameter	Conditions	Min.	Typ.	Max.	Units
Compliance	802.11b/g/n/ac/ax				
Operating Frequency	CH1-CH13	2402.5		2481.5	MHz
Operating Temperature		-40		+95	°C
Power Supply VCC		3.13	3.3	5.25	V
Control Voltage-High		1.8	3.0	3.3	V
Control Voltage-Low			0	0.5	V

Degraded performance at extended operating range.

Logic Truth Table

Operating Mode	VPD	VBYP
Standby	High	Low
High Gain Mode	Low	Low
Bypass Mode	Low	High
Unutilized state (LNAOFF, Bypass is ON)	High	High

Electrical Specifications – 3.3V

Parameter	Conditions	Min.	Typ.	Max.	Units
Frequency Range	VCC=3.3V, T=25°C unless otherwise noted; CH1-13	2402.5	-	2481.5	MHz
Gain – LNA mode	LNA Enabled	10	13	-	dB
Gain – Bypass mode	LNA Disabled	-	-8.0	-	dB
Gain Flatness – LNA mode	For any 19 MHz channel over the frequency range. Ch: 2-12.	-	0.6	2.0	dB
Gain Flatness – LNA mode	For any 19 MHz channel over the frequency range. Ch: 1 and 13.	-	0.9	2.5	dB
Noise Figure – LNA mode	LNA Enabled	-	2.8	4.7	dB
Current – LNA mode	LNA Enabled	-	40	-	mA
Output IP3 – LNA mode	LNA Enabled	-	+30	-	dBm
Input P1dB – LNA mode	LNA Enabled	-	+3.5	-	dBm
Input P1dB – Bypass mode	LNA Disabled	-	+17	-	dBm
Out of Band Rejection (ref to CH6) LNA turn on/off time Return Loss – RF input LNA mode	<500MHz	-	96	-	dBc
	807 – 915	-	85	-	dBc
	699 - 803	-	91	-	dBc
	925 - 960	-	78	-	
	1427 – 1511	-	76	-	
	1427-1511, 1559-1661 (GPS)	-	73	-	
	1710 – 2170	-	50	-	
	2300 – 2370	-	36	-	
	2496-2500	-	11	-	
	2500 - 2505	-	54	-	
	2505 - 2570	-	50	-	
	2570 - 2620	-	55	-	
	2620 - 2690	-	55	-	
	3.4 – 3.8GHz	-	48	-	
	4800 – 6GHz	-	62	-	
7200 - 7500	-	58	-		
LNA turn on/off time	LNA Enabled	-	400	550	
Return Loss – RF input LNA mode	LNA Enabled	-	12	-	dB
Return Loss – RF input Bypass mode	LNA Disabled	-	12	-	dB
Return Loss – RF output LNA mode	LNA Enabled	-	15	-	dB
Return Loss – RF output Bypass mode	LNA Disabled	-	15	-	dB

Electrical Specifications – 5V

Parameter	Conditions	Min.	Typ.	Max.	Units
	VCC=5.0V, T=25°C unless otherwise noted; CH1-13				
Frequency Range		2402.5	-	2481.5	MHz
Gain – LNA mode	LNA Enabled	10	13	-	dB
Gain – Bypass mode	LNA Disabled	-	-8.0	-	dB
Gain Flatness – LNA mode	For any 19 MHz channel over the frequency range. Ch: 2-12.	-	0.6	2.0	dB
Gain Flatness – LNA mode	For any 19 MHz channel over the frequency range. Ch: 1 and 13.	-	0.9	2.5	
Noise Figure – LNA mode	LNA Enabled	-	2.8	4.7	dB
Current – LNA mode	LNA Enabled	-	60	-	mA
Output IP3 – LNA mode	LNA Enabled	-	+33	-	dBm
Input P1dB – LNA mode	LNA Enabled	-	+4.5	-	dBm
Input P1dB – Bypass mode	LNA Disabled	-	+17	-	dBm
Out of Band Rejection (ref to CH6) LNA turn on/off time Return Loss – RF input LNA mode	<500MHz	-	96	-	dBc
	807 – 915	-	85	-	dBc
	699 - 803	-	91	-	dBc
	925 - 960	-	78	-	
	1427 – 1511	-	76	-	
	1427-1511, 1559-1661 (GPS)	-	73	-	
	1710 – 2170	-	50	-	
	2300 – 2370	-	36	-	
	2496-2500	-	11	-	
	2500 - 2505	-	54	-	
	2505 - 2570	-	50	-	
	2570 - 2620	-	55	-	
	2620 - 2690	-	55	-	
	3.4 – 3.8GHz	-	48	-	
4800 – 6GHz	-	62	-		
7200 - 7500	-	58	-		
LNA turn on/off time	LNA Enabled	-	400	550	nS
Return Loss – RF input LNA mode	LNA Enabled	-	12	-	dB
Return Loss – RF input Bypass mode	LNA Disabled	-	12	-	dB
Return Loss – RF output LNA mode	LNA Enabled	-	15	-	dB
Return Loss – RF output Bypass mode	LNA Disabled	-	15	-	dB

General Specifications

Parameter	Conditions	Min.	Typ.	Max.	Units
	Vcc=5V, T=+25°C; CH1-13				
FEM Leakage Current			10		μA
Controls Current			100		μA
Switching Speed				550	nS
LNA Stability	Unconditional into 10:1 VSWR; No spurs above -41.25dBm/MHz, Pin = 0 dBm				

Evaluation Board Schematic

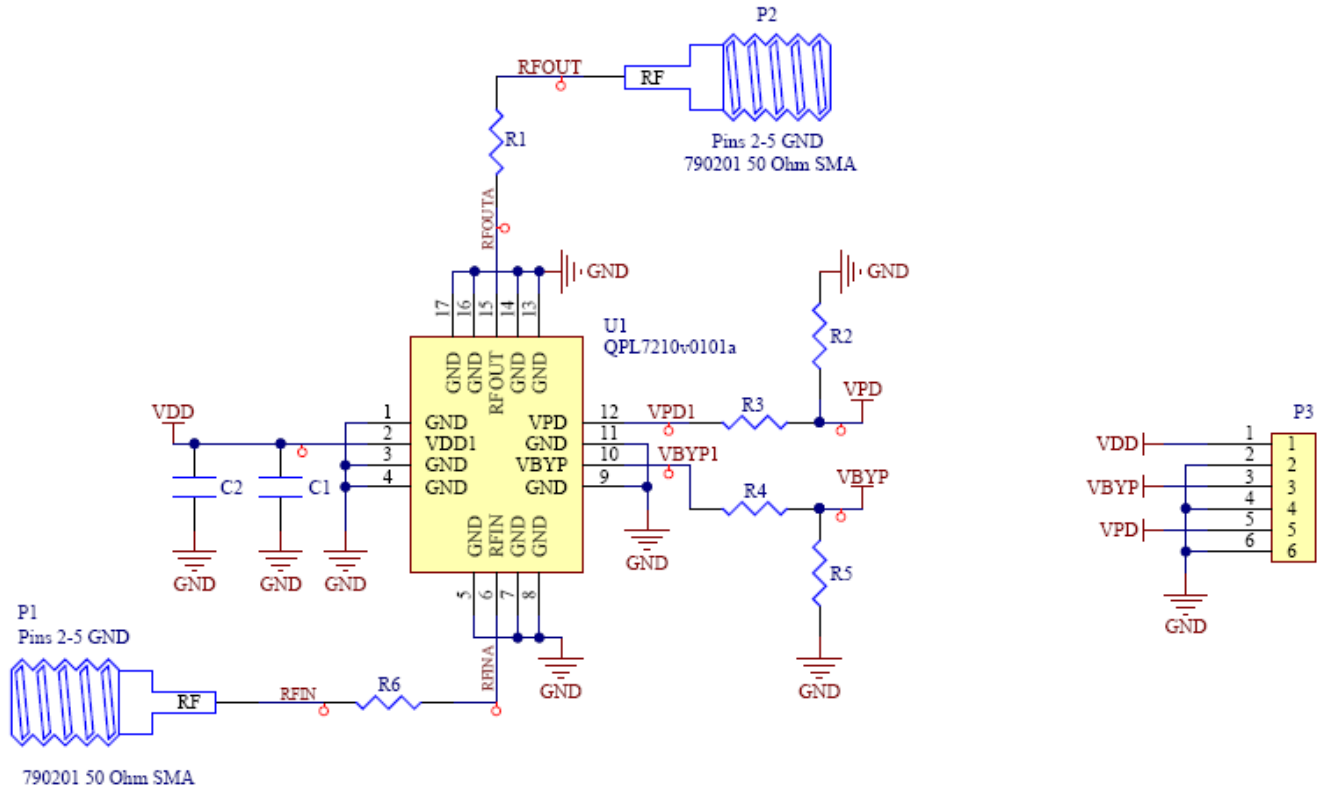

Pin Configuration and Description

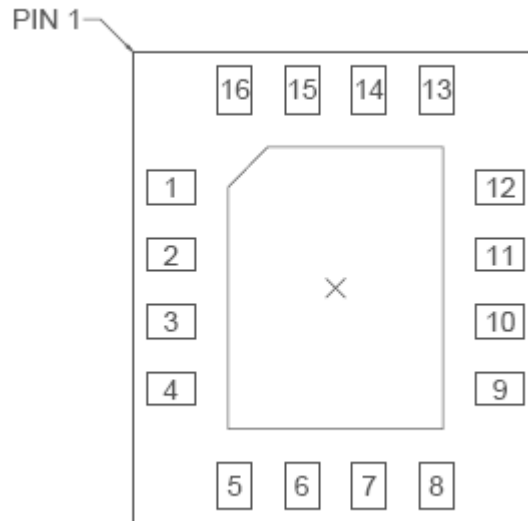

Pin Number	Label	Description
1,3,4,5,7,8,9,13,14,16	GND	Pin grounds
2	VDD1	Module Voltage supply
6	RFIN	Module RFIN
12	VPD	Module Power down, turn on and off module
11	GND	Pin ground
10	VBYP	Module Switch Bypass mode
15	RFOUT	Module RF Output
Pkg Base		Ground connection. The backside of the package should be connected to the ground plane through a short path, i.e., PCB vias under the device are recommended.

Package Outline Drawing

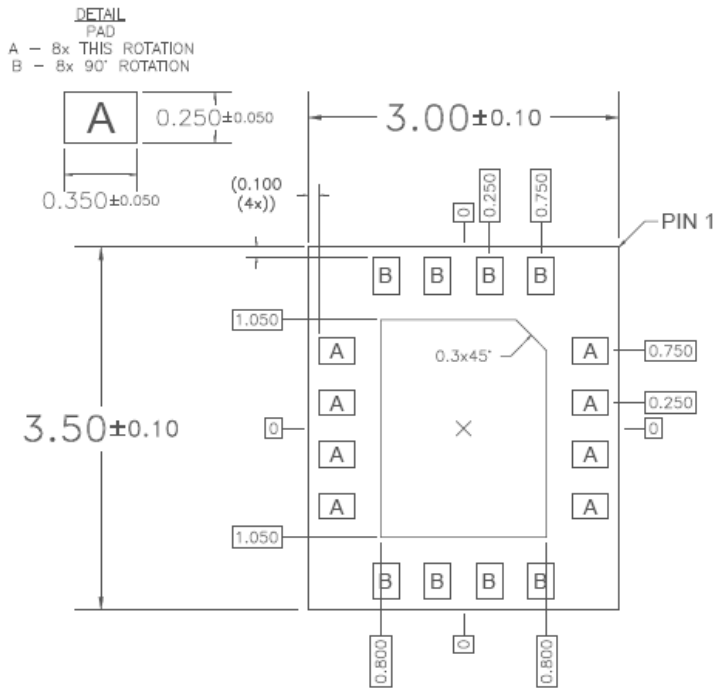

BOTTOM
VIEW

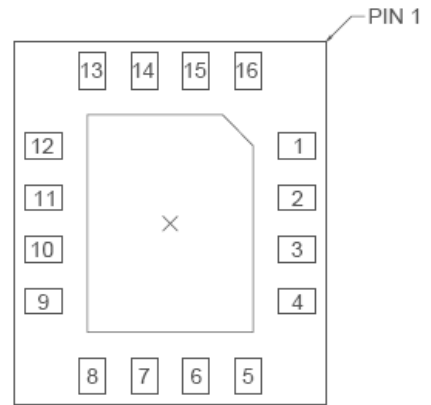

BOTTOM PINS
VIEW

Notes:

1. All dimensions are in millimeter. Angles are in degrees.
2. Dimension and tolerance formats conform to ASME Y14.4M-1994.
3. The terminal #1 identifier and terminal numbering conform to JESD 95-1 SPP-012.

PCB Mounting Patterns

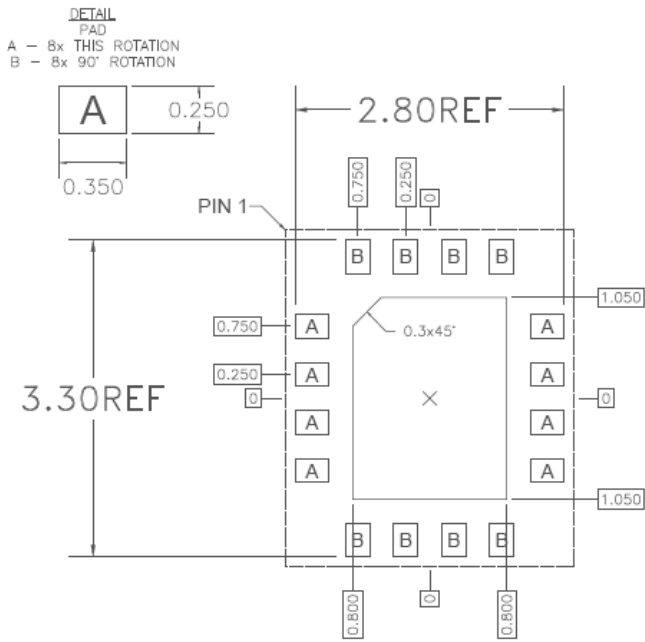

RECOMMENDED
LAND PATTERN

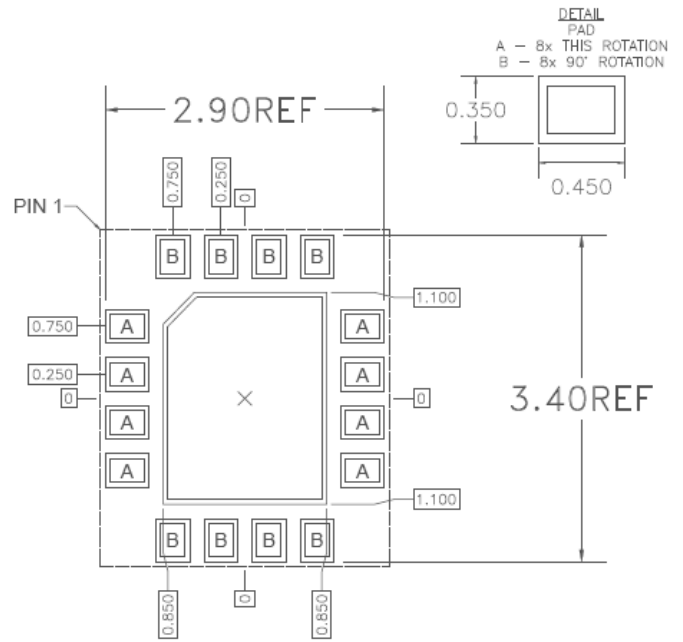

RECOMMENDED
LAND PATTERN MASK

Notes:

- 4. All dimensions are in millimeter. Angles are in degrees.
- 5. Dimension and tolerance formats conform to ASME Y14.4M-1994.
- 6. The terminal #1 identifier and terminal numbering conform to JESD 95-1 SPP-012.

Handling Precautions

Parameter	Rating	Standard
ESD – Human Body Model (HBM)	Class 1C	ESDA/JEDEC JS-001-2012
ESD – Charged Device Model (CDM)	Class C3	JEDEC JESD22-C101F
MSL – Moisture Sensitivity Level	3	IPC/JEDEC J-STD-020



Caution!

ESD sensitive device

Solderability

Compatible with both lead-free (260 °C max. reflow temperature) and tin/lead (245 °C max. reflow temperature) soldering processes.

Package lead plating: Electrolytic plated Au over Ni

RoHS Compliance

This part is compliant with the 2011/65/EU RoHS directive (Restrictions on the Use of Certain Hazardous Substances in Electrical and Electronic Equipment), as amended by Directive 2015/863/EU.

This product also has the following attributes:

- Lead free
- Halogen Free (Chlorine, Bromine)
- Antimony Free
- TBBP-A (C₁₅H₁₂Br₄O₂) Free
- SVHC Free



Contact Information

For the latest specifications, additional product information, worldwide sales and distribution locations:

Web: www.qorvo.com

Tel: 1-844-890-8163

Email: customer.support@qorvo.com

Important Notice

The information contained herein is believed to be reliable; however, Qorvo makes no warranties regarding the information contained herein and assumes no responsibility or liability whatsoever for the use of the information contained herein. All information contained herein is subject to change without notice. Customers should obtain and verify the latest relevant information before placing orders for Qorvo products. The information contained herein or any use of such information does not grant, explicitly or implicitly, to any party any patent rights, licenses, or any other intellectual property rights, whether with regard to such information itself or anything described by such information. **THIS INFORMATION DOES NOT CONSTITUTE A WARRANTY WITH RESPECT TO THE PRODUCTS DESCRIBED HEREIN, AND QORVO HEREBY DISCLAIMS ANY AND ALL WARRANTIES WITH RESPECT TO SUCH PRODUCTS WHETHER EXPRESS OR IMPLIED BY LAW, COURSE OF DEALING, COURSE OF PERFORMANCE, USAGE OF TRADE OR OTHERWISE, INCLUDING THE IMPLIED WARRANTIES OF MERCHANTABILITY AND FITNESS FOR A PARTICULAR PURPOSE.**

Without limiting the generality of the foregoing, Qorvo products are not warranted or authorized for use as critical components in medical, life-saving, or life-sustaining applications, or other applications where a failure would reasonably be expected to cause severe personal injury or death.

Copyright 2016 © Qorvo, Inc. | Qorvo is a registered trademark of Qorvo, Inc.



Стандарт Электрон Связь

Мы молодая и активно развивающаяся компания в области поставок электронных компонентов. Мы поставляем электронные компоненты отечественного и импортного производства напрямую от производителей и с крупнейших складов мира.

Благодаря сотрудничеству с мировыми поставщиками мы осуществляем комплексные и плановые поставки широчайшего спектра электронных компонентов.

Собственная эффективная логистика и склад в обеспечивает надежную поставку продукции в точно указанные сроки по всей России.

Мы осуществляем техническую поддержку нашим клиентам и предпродажную проверку качества продукции. На все поставляемые продукты мы предоставляем гарантию .

Осуществляем поставки продукции под контролем ВП МО РФ на предприятия военно-промышленного комплекса России , а также работаем в рамках 275 ФЗ с открытием отдельных счетов в уполномоченном банке. Система менеджмента качества компании соответствует требованиям ГОСТ ISO 9001.

Минимальные сроки поставки, гибкие цены, неограниченный ассортимент и индивидуальный подход к клиентам являются основой для выстраивания долгосрочного и эффективного сотрудничества с предприятиями радиоэлектронной промышленности, предприятиями ВПК и научно-исследовательскими институтами России.

С нами вы становитесь еще успешнее!

Наши контакты:

Телефон: +7 812 627 14 35

Электронная почта: sales@st-electron.ru

Адрес: 198099, Санкт-Петербург,
Промышленная ул, дом № 19, литера Н,
помещение 100-Н Офис 331