

### FEATURES

- JESD204B (Subclass 1) coded serial digital outputs
- Support for lane rates up to 16 Gbps per lane
- 1.65 W total power per channel at 3 GSPS (default settings)
- Performance at  $-2$  dBFS amplitude, 2.6 GHz input
  - SFDR = 70 dBFS
  - SNR = 57.2 dBFS
- Performance at  $-9$  dBFS amplitude, 2.6 GHz input
  - SFDR = 78 dBFS
  - SNR = 59.5 dBFS
- Integrated input buffer
- Noise density =  $-152$  dBFS/Hz
- 0.975 V, 1.9 V, and 2.5 V dc supply operation
- 9 GHz analog input full power bandwidth ( $-3$  dB)
- Amplitude detect bits for efficient AGC implementation

- 2 integrated, wideband digital processors per channel
- 48-bit NCO
- 4 cascaded half-band filters
- Phase coherent NCO switching
- Up to 4 channels available
- Serial port control
  - Integer clock with divide by 2 and divide by 4 options
- Flexible JESD204B lane configurations
- On-chip dither

### APPLICATIONS

- Diversity multiband and multimode digital receivers
- 3G/4G, TD-SCDMA, W-CDMA, and GSM, LTE, LTE-A
- Electronic test and measurement systems
- Phased array radar and electronic warfare
- DOCSIS 3.0 CMTS upstream receive paths
- HFC digital reverse path receivers

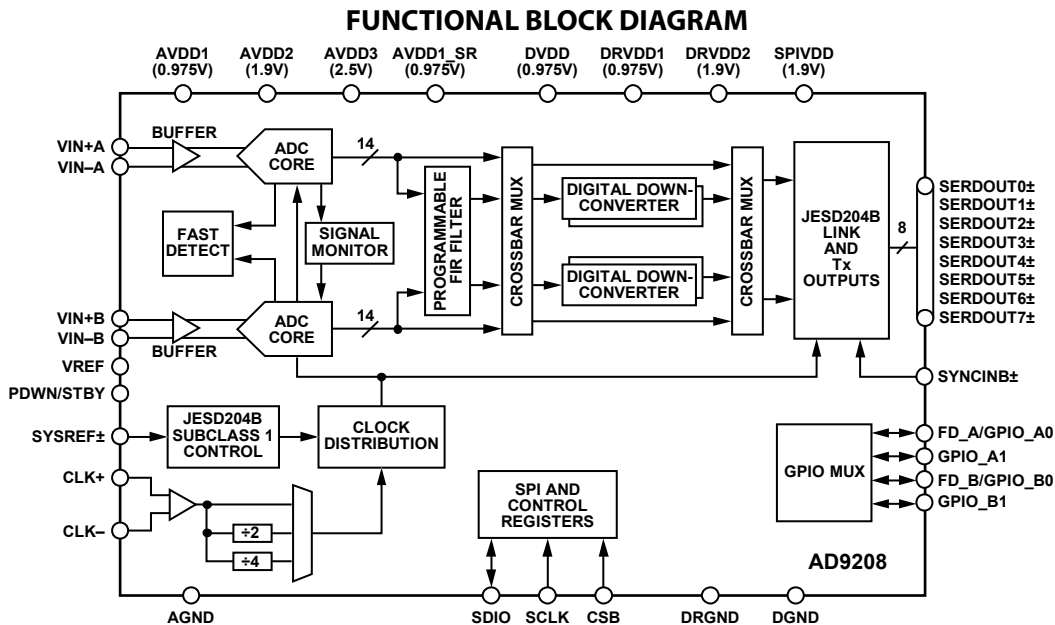

Figure 1.

15547-001

## TABLE OF CONTENTS

|   |    |   |     |
|---|----|---|-----|
| Features .....  | 1  | DDC Complex to Real Conversion .....                | 57  |
| Applications.....   | 1  | DDC Mixed Decimation Settings .....                 | 58  |
| Functional Block Diagram .....                                | 1  | DDC Example Configurations .....                    | 59  |
| Revision History .....  | 3  | DDC Power Consumption.....                          | 63  |
| General Description .....                                     | 4  | Signal Monitor .....                                | 64  |
| Specifications.....   | 5  | SPORT over JESD204B.....                            | 65  |
| DC Specifications .....                                       | 5  | Digital Outputs .....                               | 67  |
| AC Specifications.....  | 6  | Introduction to the JESD204B Interface .....        | 67  |
| Digital Specifications .....                                  | 7  | JESD204B Overview .....                             | 67  |
| Switching Specifications .....                                | 9  | Functional Overview .....                           | 68  |
| Timing Specifications .....                                   | 10 | JESD204B Link Establishment .....                   | 68  |
| Absolute Maximum Ratings.....                                 | 12 | Physical Layer (Driver) Outputs .....               | 70  |
| Thermal Resistance .....                                      | 12 | $f_s \times 4$ Mode.....                            | 71  |
| ESD Caution.....  | 12 | Setting Up the AD9208 digital interface.....        | 72  |
| Pin Configuration and Function Descriptions.....              | 13 | Deterministic Latency.....                          | 78  |
| Typical Performance Characteristics .....                     | 16 | Subclass 0 Operation.....                           | 78  |
| Equivalent Circuits .....                                     | 22 | Subclass 1 Operation.....                           | 78  |
| Theory of Operation .....                                     | 24 | Multichip Synchronization.....                      | 80  |
| ADC Architecture .....  | 24 | Normal Mode.....                                    | 80  |
| Analog Input Considerations.....                              | 24 | Timestamp Mode .....                                | 80  |
| Voltage Reference .....                                       | 28 | SYSREF Input.....                                   | 82  |
| DC Offset Calibration.....                                    | 29 | SYSREF $\pm$ Setup/Hold Window Monitor.....         | 84  |
| Clock Input Considerations .....                              | 29 | Latency.....  | 86  |
| Power-Down/Standby Mode.....                                  | 31 | End to End Total Latency.....                       | 86  |
| Temperature Diode .....                                       | 31 | Example Latency Calculations.....                   | 86  |
| ADC Overage and Fast Detect.....                              | 33 | LMFC Referenced Latency.....                        | 86  |
| ADC Overage.....  | 33 | Test Modes.....                                     | 88  |
| Fast Threshold Detection (FD_A and FD_B) .....                | 33 | ADC Test Modes .....                                | 88  |
| ADC Application Modes and JESD204B Tx Converter Mapping ..... | 34 | JESD204B Block Test Modes .....                     | 89  |
| Programmable FIR filters .....                                | 36 | Serial Port Interface.....                          | 91  |
| Supported Modes.....  | 36 | Configuration Using the SPI.....                    | 91  |
| Programming Instructions.....                                 | 38 | Hardware Interface.....                             | 91  |
| Digital Downconverter (DDC).....                              | 40 | SPI Accessible Features.....                        | 91  |
| DDC I/Q Input Selection .....                                 | 40 | Memory Map .....                                    | 92  |
| DDC I/Q Output Selection .....                                | 40 | Reading the Memory Map Register Table.....          | 92  |
| DDC General Description .....                                 | 40 | Memory Map Register Details.....                    | 93  |
| DDC Frequency Translation.....                                | 43 | Applications Information .....                      | 134 |
| DDC Decimation Filters.....                                   | 51 | Power Supply Recommendations.....                   | 134 |
| DDC Gain Stage .....  | 57 | Layout Guidelines.....                              | 135 |
|   |    | AVDD1_SR (Pin E7) and AGND (Pin E6 and Pin E8)..... | 135 |

Outline Dimensions..... 136  
Ordering Guide ..... 136

**REVISION HISTORY**

4/2017—Revision 0: Initial Version

## GENERAL DESCRIPTION

The [AD9208](#) is a dual, 14-bit, 3 GSPS analog-to-digital converter (ADC). The device has an on-chip buffer and a sample-and-hold circuit designed for low power, small size, and ease of use. This product is designed to support communications applications capable of direct sampling wide bandwidth analog signals of up to 5 GHz. The  $-3$  dB bandwidth of the ADC input is 9 GHz. The [AD9208](#) is optimized for wide input bandwidth, high sampling rate, excellent linearity, and low power in a small package.

The dual ADC cores feature a multistage, differential pipelined architecture with integrated output error correction logic. Each ADC features wide bandwidth inputs supporting a variety of user-selectable input ranges. An integrated voltage reference eases design considerations. The analog input and clock signals are differential inputs. The ADC data outputs are internally connected to four digital downconverters (DDCs) through a crossbar mux. Each DDC consists of up to five cascaded signal processing stages: a 48-bit frequency translator (numerically controlled oscillator (NCO)), and up to four half-band decimation filters. The NCO has the option to select preset bands over the general-purpose input/output (GPIO) pins, which enables the selection of up to three bands. Operation of the [AD9208](#) between the DDC modes is selectable via SPI-programmable profiles.

In addition to the DDC blocks, the [AD9208](#) has several functions that simplify the automatic gain control (AGC) function in a communications receiver. The programmable threshold detector allows monitoring of the incoming signal power using the fast detect control bits in Register 0x0245 of the ADC. If the input signal level exceeds the programmable threshold, the fast detect indicator goes high. Because this threshold indicator has low latency, the user can quickly turn down the system gain to avoid an overrange condition at the ADC input. In addition to the fast detect outputs, the [AD9208](#) also offers signal monitoring

capability. The signal monitoring block provides additional information about the signal being digitized by the ADC.

The user can configure the Subclass 1 JESD204B-based high speed serialized output in a variety of one-lane, two-lane, four-lane, and eight-lane configurations, depending on the DDC configuration and the acceptable lane rate of the receiving logic device. Multidevice synchronization is supported through the  $\text{SYSREF}\pm$  and  $\text{SYNCINB}\pm$  input pins.

The [AD9208](#) has flexible power-down options that allow significant power savings when desired. All of these features can be programmed using a 3-wire serial port interface (SPI).

The [AD9208](#) is available in a Pb-free, 196-ball BGA, specified over the  $-40^{\circ}\text{C}$  to  $+85^{\circ}\text{C}$  ambient temperature range. This product is protected by a U.S. patent.

Note that throughout this data sheet, multifunction pins, such as  $\text{FD\_A}/\text{GPIO\_A0}$ , are referred to either by the entire pin name or by a single function of the pin, for example,  $\text{FD\_A}$ , when only that function is relevant.

## PRODUCT HIGHLIGHTS

1. Wide, input  $-3$  dB bandwidth of 9 GHz supports direct radio frequency (RF) sampling of signals up to about 5 GHz.
2. Four integrated, wideband decimation filter and NCO blocks supporting multiband receivers.
3. Fast NCO switching enabled through the GPIO pins.
4. A SPI controls various product features and functions to meet specific system requirements.
5. Programmable fast overrange detection and signal monitoring.
6. On-chip temperature diode for system thermal management.
7.  $12\text{ mm} \times 12\text{ mm}$ , 196-ball BGA.

## SPECIFICATIONS

### DC SPECIFICATIONS

AVDD1 = 0.975 V, AVDD1\_SR = 0.975 V, AVDD2 = 1.9 V, AVDD3 = 2.5 V, DVDD = 0.975 V, DRVDD1 = 0.975 V, DRVDD2 = 1.9 V, SPIVDD = 1.9 V, specified maximum sampling rate, 1.7 V p-p full-scale differential input, input amplitude ( $A_{IN}$ ) = -2.0 dBFS, L = 8, M = 2, F = 1,  $-10^{\circ}\text{C} \leq T_J \leq +120^{\circ}\text{C}$ ,<sup>1</sup> unless otherwise noted. Typical specifications represent performance at  $T_J = 70^{\circ}\text{C}$  ( $T_A = 25^{\circ}\text{C}$ ).

Table 1.

| Parameter   | Min   | Typ        | Max   | Unit    |
|---|-------|------------|-------|---------|
| RESOLUTION  | 14    |            |       | Bits    |
| ACCURACY  |       | Guaranteed |       |         |
| No Missing Codes  |       | 0          |       | %FSR    |
| Offset Error  |       | 0          |       | %FSR    |
| Offset Matching   |       | 0          |       | %FSR    |
| Gain Error  | -5.89 | ±1         | +5.89 | %FSR    |
| Gain Matching   | -2.9  | ±0.2       | +2.9  | %FSR    |
| Differential Nonlinearity (DNL)                                 | -0.63 | ±0.4       | +0.74 | LSB     |
| Integral Nonlinearity (INL)                                     | -26   | ±6         | +21   | LSB     |
| TEMPERATURE DRIFT   |       |            |       |         |
| Offset Error  |       | ±15        |       | ppm/°C  |
| Gain Error  |       | 440        |       | ppm/°C  |
| INTERNAL VOLTAGE REFERENCE                                      |       | 0.5        |       | V       |
| INPUT-REFERRED NOISE  |       | 5.6        |       | LSB rms |
| ANALOG INPUTS   |       |            |       |         |
| Differential Input Voltage Range                                |       | 1.7        |       | V p-p   |
| Common-Mode Voltage ( $V_{CM}$ )                                | 1.32  | 1.35       | 1.52  | V       |
| Differential Input Resistance                                   |       | 200        |       | Ω       |
| Differential Input Capacitance                                  |       | 0.25       |       | pF      |
| Differential Input Return Loss at 2.1 GHz <sup>2</sup>          |       | -7         |       | dB      |
| -3 dB Bandwidth   |       | 9          |       | GHz     |
| POWER SUPPLY  |       |            |       |         |
| AVDD1   | 0.95  | 0.975      | 1.0   | V       |
| AVDD2   | 1.85  | 1.9        | 1.95  | V       |
| AVDD3   | 2.44  | 2.5        | 2.56  | V       |
| AVDD1_SR  | 0.95  | 0.975      | 1.0   | V       |
| DVDD  | 0.95  | 0.975      | 1.0   | V       |
| DRVDD1  | 0.95  | 0.975      | 1.0   | V       |
| DRVDD2  | 1.85  | 1.9        | 1.95  | V       |
| SPIVDD  | 1.85  | 1.9        | 1.95  | V       |
| $I_{AVDD1}$   |       | 640        | 765   | mA      |
| $I_{AVDD2}$   |       | 790        | 885   | mA      |
| $I_{AVDD3}$   |       | 110        | 120   | mA      |
| $I_{AVDD1\_SR}$   |       | 24         | 50    | mA      |
| $I_{DVDD}$  |       | 480        | 1020  | mA      |
| $I_{DRVDD1}$ <sup>3</sup>                                       |       | 320        | 590   | mA      |
| $I_{DRVDD2}$  |       | 30         | 35    | mA      |
| $I_{SPIVDD}$  |       | 1          | 5     | mA      |
| POWER CONSUMPTION   |       |            |       |         |
| Total Power Dissipation (Including Output Drivers) <sup>4</sup> |       | 3.3        |       | W       |
| Power-Down Dissipation  |       | 300        |       | mW      |
| Standby <sup>5</sup>  |       | 1.65       |       | mW      |

<sup>1</sup> The junction temperature ( $T_J$ ) range of  $-10^{\circ}\text{C}$  to  $+120^{\circ}\text{C}$  translates to an ambient temperature ( $T_A$ ) range of  $-40^{\circ}\text{C}$  to  $+85^{\circ}\text{C}$ .

<sup>2</sup> For more information, see the Analog Input Considerations section.

<sup>3</sup> All lanes running. Power dissipation on DRVDD1 changes with lane rate and number of lanes used.

<sup>4</sup> Default mode. No DDCs used.

<sup>5</sup> Can be controlled by the SPI.

**AC SPECIFICATIONS**

AVDD1 = 0.975 V, AVDD1\_SR = 0.975 V, AVDD2 = 1.9 V, AVDD3 = 2.5 V, DVDD = 0.975 V, DRVDD1 = 0.975 V, DRVDD2 = 1.9 V, SPIVDD = 1.9 V, specified maximum sampling rate, 1.7 V p-p full-scale differential input, default SPI settings,  $-10^{\circ}\text{C} \leq T_J \leq +120^{\circ}\text{C}$ ,<sup>1</sup> unless otherwise noted. Typical specifications represent performance at  $T_J = 70^{\circ}\text{C}$  ( $T_A = 25^{\circ}\text{C}$ ).

**Table 2.**

| Parameter <sup>2</sup>                                       | $A_{IN} = -2 \text{ dBFS}$ |      |     | $A_{IN} = -9 \text{ dBFS}$ |      |     | Unit    |
|--|----------------------------|------|-----|----------------------------|------|-----|---------|
|  | Min                        | Typ  | Max | Min                        | Typ  | Max |         |
| NOISE DENSITY <sup>3</sup>                                   |                            |      |     |                            |      |     |         |
| 1.7 V p-p Setting  |                            | -152 |     |                            | -152 |     | dBFS/Hz |
| 2.04 V p-p Setting   |                            | -154 |     |                            | -154 |     | dBFS/Hz |
| NOISE FIGURE   |                            | 24.5 |     |                            | 24.5 |     | dB      |
| SIGNAL-TO-NOISE RATIO (SNR)                                  |                            |      |     |                            |      |     |         |
| $f_{IN} = 255 \text{ MHz}$                                   |                            | 60.2 |     |                            | 60.2 |     | dBFS    |
| $f_{IN} = 255 \text{ MHz}$ (2.04 V p-p Setting)              |                            | 61.4 |     |                            | 61.8 |     | dBFS    |
| $f_{IN} = 765 \text{ MHz}$                                   |                            | 59.8 |     |                            | 60.2 |     | dBFS    |
| $f_{IN} = 900 \text{ MHz}$                                   |                            | 59.5 |     |                            | 60.2 |     | dBFS    |
| $f_{IN} = 1800 \text{ MHz}$                                  |                            | 58.7 |     |                            | 60.0 |     | dBFS    |
| $f_{IN} = 2100 \text{ MHz}$                                  |                            | 58.2 |     |                            | 59.8 |     | dBFS    |
| $f_{IN} = 2600 \text{ MHz}$                                  | 52.1                       | 57.2 |     |                            | 59.5 |     | dBFS    |
| $f_{IN} = 3950 \text{ MHz}$                                  |                            | 55.1 |     |                            | 58.6 |     | dBFS    |
| SIGNAL-TO-NOISE-AND-DISTORTION RATIO (SINAD)                 |                            |      |     |                            |      |     |         |
| $f_{IN} = 255 \text{ MHz}$                                   |                            | 59.7 |     |                            | 60.0 |     | dBFS    |
| $f_{IN} = 255 \text{ MHz}$ (2.04 V p-p Setting)              |                            | 60.0 |     |                            | 61.5 |     | dBFS    |
| $f_{IN} = 765 \text{ MHz}$                                   |                            | 58.8 |     |                            | 60.0 |     | dBFS    |
| $f_{IN} = 900 \text{ MHz}$                                   |                            | 58.6 |     |                            | 59.9 |     | dBFS    |
| $f_{IN} = 1800 \text{ MHz}$                                  |                            | 57.4 |     |                            | 59.7 |     | dBFS    |
| $f_{IN} = 2100 \text{ MHz}$                                  |                            | 56.7 |     |                            | 59.4 |     | dBFS    |
| $f_{IN} = 2600 \text{ MHz}$                                  | 46.6                       | 56.1 |     |                            | 59.2 |     | dBFS    |
| $f_{IN} = 3950 \text{ MHz}$                                  |                            | 52.8 |     |                            | 58.2 |     | dBFS    |
| EFFECTIVE NUMBER OF BITS (ENOB)                              |                            |      |     |                            |      |     |         |
| $f_{IN} = 255 \text{ MHz}$                                   |                            | 9.6  |     |                            | 9.7  |     | Bits    |
| $f_{IN} = 765 \text{ MHz}$                                   |                            | 9.5  |     |                            | 9.7  |     | dBFS    |
| $f_{IN} = 900 \text{ MHz}$                                   |                            | 9.4  |     |                            | 9.7  |     | Bits    |
| $f_{IN} = 1800 \text{ MHz}$                                  |                            | 9.2  |     |                            | 9.6  |     | Bits    |
| $f_{IN} = 2100 \text{ MHz}$                                  |                            | 9.1  |     |                            | 9.6  |     | Bits    |
| $f_{IN} = 2600 \text{ MHz}$                                  | 7.5                        | 9.0  |     |                            | 9.5  |     | Bits    |
| $f_{IN} = 3950 \text{ MHz}$                                  |                            | 8.5  |     |                            | 9.4  |     | Bits    |
| SPURIOUS-FREE DYNAMIC RANGE (SFDR), SECOND OR THIRD HARMONIC |                            |      |     |                            |      |     |         |
| $f_{IN} = 255 \text{ MHz}$                                   |                            | 71   |     |                            | 78   |     | dBFS    |
| $f_{IN} = 255 \text{ MHz}$ (2.04 V p-p Setting)              |                            | 65   |     |                            | 83   |     | dBFS    |
| $f_{IN} = 765 \text{ MHz}$                                   |                            | 71   |     |                            | 79   |     | dBFS    |
| $f_{IN} = 900 \text{ MHz}$                                   |                            | 71   |     |                            | 78   |     | dBFS    |
| $f_{IN} = 1800 \text{ MHz}$                                  |                            | 69   |     |                            | 81   |     | dBFS    |
| $f_{IN} = 2100 \text{ MHz}$                                  |                            | 67   |     |                            | 73   |     | dBFS    |
| $f_{IN} = 2600 \text{ MHz}$                                  | 51                         | 70   |     |                            | 78   |     | dBFS    |
| $f_{IN} = 3950 \text{ MHz}$                                  |                            | 58   |     |                            | 73   |     | dBFS    |

| Parameter <sup>2</sup>  | A <sub>IN</sub> = -2 dBFS |     |     | A <sub>IN</sub> = -9 dBFS |     |     | Unit |
|---|---------------------------|-----|-----|---------------------------|-----|-----|------|
|   | Min                       | Typ | Max | Min                       | Typ | Max |      |
| WORST OTHER, EXCLUDING SECOND OR THIRD HARMONIC   |                           |     |     |                           |     |     |      |
| f <sub>IN</sub> = 255 MHz   |                           | -89 |     | -90                       |     |     | dBFS |
| f <sub>IN</sub> = 255 MHz (2.04 V p-p Setting)  |                           | -90 |     | -90                       |     |     | dBFS |
| f <sub>IN</sub> = 765 MHz   |                           | -90 |     | -89                       |     |     | dBFS |
| f <sub>IN</sub> = 900 MHz   |                           | -89 |     | -90                       |     |     | dBFS |
| f <sub>IN</sub> = 1800 MHz  |                           | -81 |     | -94                       |     |     | dBFS |
| f <sub>IN</sub> = 2100 MHz  |                           | -80 |     | -98                       |     |     | dBFS |
| f <sub>IN</sub> = 2600 MHz  | -75                       | -84 |     | -90                       |     |     | dBFS |
| f <sub>IN</sub> = 3950 MHz  |                           | -80 |     | -90                       |     |     | dBFS |
| TWO-TONE, THIRD-ORDER INTERMODULATION DISTORTION (IMD3)   |                           |     |     |                           |     |     |      |
| f <sub>IN1</sub> = 1.842 GHz, f <sub>IN2</sub> = 1.847 GHz, A <sub>IN1</sub> and A <sub>IN2</sub> = -8.0 dBFS   |                           | -73 |     |                           |     |     | dBFS |
| f <sub>IN1</sub> = 1.842 GHz, f <sub>IN2</sub> = 1.847 GHz, A <sub>IN1</sub> and A <sub>IN2</sub> = -15.0 dBFS  |                           |     |     | -87                       |     |     | dBFS |
| f <sub>IN1</sub> = 2.62 GHz, f <sub>IN2</sub> = 2.69 GHz, A <sub>IN1</sub> and A <sub>IN2</sub> = -8.0 dBFS   |                           | -69 |     |                           |     |     | dBFS |
| f <sub>IN1</sub> = 2.62 GHz, f <sub>IN2</sub> = 2.69 GHz, A <sub>IN1</sub> and A <sub>IN2</sub> = -15.0 dBFS  |                           |     |     | -88                       |     |     | dBFS |
| f <sub>IN1</sub> = 2.62 GHz, f <sub>IN2</sub> = 2.69 GHz, A <sub>IN1</sub> and A <sub>IN2</sub> = -8.0 dBFS; Full-Scale Voltage (V <sub>FS</sub> ) = 1.13 V p-p |                           | -75 |     |                           |     |     | dBFS |
| f <sub>IN1</sub> = 2.62 GHz, f <sub>IN2</sub> = 2.69 GHz, A <sub>IN1</sub> and A <sub>IN2</sub> = -15.0 dBFS; V <sub>FS</sub> = 1.13 V p-p                      |                           |     |     | -111                      |     |     | dBFS |
| CROSSTALK <sup>4</sup>  |                           | >90 |     | >90                       |     |     | dB   |
| Overrange Condition <sup>5</sup>  |                           | >90 |     | >90                       |     |     | dB   |
| ANALOG INPUT BANDWIDTH, FULL POWER <sup>6</sup>   |                           | 5   |     | 5                         |     |     | GHz  |

<sup>1</sup> The junction temperature (T<sub>J</sub>) range of -10°C to +120°C translates to an ambient temperature (T<sub>A</sub>) range of -40°C to +85°C.

<sup>2</sup> See the AN-835 Application Note, *Understanding High Speed ADC Testing and Evaluation*, for definitions and for details on how these tests were completed.

<sup>3</sup> Noise density is measured at a low analog input frequency (30 MHz).

<sup>4</sup> Crosstalk is measured at 950 MHz with a -1.0 dBFS analog input on one channel, and no input on the adjacent channel.

<sup>5</sup> The overrange condition is specified with 3 dB of the full-scale input range.

<sup>6</sup> Full power bandwidth is the bandwidth of operation in which proper ADC performance can be achieved.

## DIGITAL SPECIFICATIONS

AVDD1 = 0.975 V, AVDD1\_SR = 0.975 V, AVDD2 = 1.9 V, AVDD3 = 2.5 V, DVDD = 0.975 V, DRVDD1 = 0.975 V, DRVDD2 = 1.9 V, SPIVDD = 1.9 V, specified maximum sampling rate, 1.7 V p-p full-scale differential input, A<sub>IN</sub> = -2.0 dBFS, L = 8, M = 2, F = 1, -10°C ≤ T<sub>J</sub> ≤ +120°C,<sup>1</sup> unless otherwise noted. Typical specifications represent performance at T<sub>J</sub> = 70°C (T<sub>A</sub> = 25°C).

Table 3.

| Parameter   | Min           | Typ         | Max           | Unit   |
|---|---------------|-------------|---------------|--------|
| CLOCK INPUTS (CLK+, CLK-)   |               |             |               |        |
| Logic Compliance  |               | LVDS/LVPECL |               |        |
| Differential Input Voltage  | 300           | 800         | 1800          | mV p-p |
| Input Common-Mode Voltage   |               | 0.675       |               | V      |
| Input Resistance (Differential)   |               | 106         |               | Ω      |
| Input Capacitance   |               | 0.9         |               | pF     |
| Differential Input Return Loss at 3 GHz <sup>2</sup>                                    |               | -9.4        |               | dB     |
| SYSTEM REFERENCE (SYSREF) INPUTS (SYSREF+, SYSREF-)                                     |               |             |               |        |
| Logic Compliance  |               | LVDS/LVPECL |               |        |
| Differential Input Voltage  | 400           | 800         | 1800          | mV p-p |
| Input Common-Mode Voltage   |               | 0.675       | 2.0           | V      |
| Input Resistance (Differential)   |               | 18          |               | kΩ     |
| Input Capacitance (Differential)  |               | 1           |               | pF     |
| LOGIC INPUTS (SDIO, SCLK, CSB, PDWN/STBY, FD_A/GPIO_A0, FD_B/GPIO_B0, GPIO_A1, GPIO_B1) |               |             |               |        |
| Logic Compliance  |               | CMOS        |               |        |
| Logic 1 Voltage   | 0.65 × SPIVDD |             |               | V      |
| Logic 0 Voltage   | 0             |             | 0.35 × SPIVDD | V      |
| Input Resistance  |               | 30          |               | kΩ     |

| Parameter  | Min                        | Typ         | Max                        | Unit       |
|--|----------------------------|-------------|----------------------------|------------|
| LOGIC OUTPUTS (SDIO, FD_A, FD_B)                             |                            |             |                            |            |
| Logic Compliance   |                            | CMOS        |                            |            |
| Logic 1 Voltage ( $I_{OH} = 4 \text{ mA}$ )                  | SPIVDD – 0.45V             |             |                            | V          |
| Logic 0 Voltage ( $I_{OL} = 4 \text{ mA}$ )                  | 0                          |             | 0.45                       | V          |
| SYNCIN INPUT (SYNCINB+/SYNCINB–)                             |                            |             |                            |            |
| Logic Compliance   |                            | LVDS/LVPECL |                            |            |
| Differential Input Voltage                                   | 400                        | 800         | 1800                       | mV p-p     |
| Input Common-Mode Voltage                                    |                            | 0.675       | 2.0                        | V          |
| Input Resistance (Differential)                              |                            | 18          |                            | k $\Omega$ |
| Input Capacitance  |                            | 1           |                            | pF         |
| SYNCINB+ INPUT   |                            |             |                            |            |
| Logic Compliance   |                            | CMOS        |                            |            |
| Logic 1 Voltage  | $0.9 \times \text{DRVDD1}$ |             | $2 \times \text{DRVDD1}$   | V          |
| Logic 0 Voltage  |                            |             | $0.1 \times \text{DRVDD1}$ | V          |
| Input Resistance   |                            | 2.6         |                            | k $\Omega$ |
| DIGITAL OUTPUTS (SERDOUT $x_{\pm}$ , $x = 0 \text{ TO } 7$ ) |                            |             |                            |            |
| Logic Compliance   |                            | SST         |                            |            |
| Differential Output Voltage                                  | 360                        | 560         | 770                        | mV p-p     |
| Differential Termination Impedance                           | 80                         | 100         | 120                        | $\Omega$   |

<sup>1</sup> The junction temperature ( $T_J$ ) range of  $-10^\circ\text{C}$  to  $+120^\circ\text{C}$  translates to an ambient temperature ( $T_A$ ) range of  $-40^\circ\text{C}$  to  $+85^\circ\text{C}$ .

<sup>2</sup> Reference impedance = 100  $\Omega$ .



**SWITCHING SPECIFICATIONS**

AVDD1 = 0.975 V, AVDD1\_SR = 0.975 V, AVDD2 = 1.9 V, AVDD3 = 2.5 V, DVDD = 0.975 V, DRVDD1 = 0.975 V, DRVDD2 = 1.9 V, SPIVDD = 1.9 V, specified maximum sampling rate, 1.7 V p-p full-scale differential input,  $A_{IN} = -2.0$  dBFS, default SPI settings,  $-10^{\circ}\text{C} \leq T_j \leq +120^{\circ}\text{C}$ ,<sup>1</sup> unless otherwise noted. Typical specifications represent performance at  $T_j = 70^{\circ}\text{C}$  ( $T_A = 25^{\circ}\text{C}$ ).

**Table 4.**

| Parameter   | Min    | Typ    | Max    | Unit          |
|---|--------|--------|--------|---------------|
| <b>CLOCK</b>  |        |        |        |               |
| Clock Rate (at CLK+/CLK– Pins)                          |        | 3      | 6      | GHz           |
| Sample Rate <sup>2</sup>                                | 2500   | 3000   | 3100   | MSPS          |
| Clock Pulse Width High                                  | 161.29 | 166.67 | 192.31 | ps            |
| Clock Pulse Width Low                                   | 161.29 | 166.67 | 192.31 | ps            |
| <b>OUTPUT PARAMETERS</b>                                |        |        |        |               |
| Unit Interval (UI) <sup>3</sup>                         | 62.5   | 66.67  | 592.6  | ps            |
| Rise Time ( $t_R$ ) (20% to 80% into 100 $\Omega$ Load) |        | 26     |        | ps            |
| Fall Time ( $t_F$ ) (20% to 80% into 100 $\Omega$ Load) |        | 26     |        | ps            |
| Phase-Locked Loop (PLL) Lock Time                       |        | 5      |        | ms            |
| Data Rate per Channel (Nonreturn to Zero) <sup>4</sup>  | 1.6875 | 15     | 16     | Gbps          |
| <b>LATENCY<sup>5</sup></b>                              |        |        |        |               |
| Pipeline Latency <sup>6</sup>                           |        | 75     |        | Clock cycles  |
| Fast Detect Latency                                     |        | 26     |        | Clock cycles  |
| <b>WAKE-UP TIME</b>                                     |        |        |        |               |
| Standby   |        | 400    |        | $\mu\text{s}$ |
| Power-Down  |        | 15     |        | ms            |
| <b>NCO CHANNEL SELECTION TO OUTPUT</b>                  |        |        | 8      | Clock cycles  |
| <b>APERTURE</b>   |        |        |        |               |
| Aperture Delay ( $t_A$ )                                |        | 250    |        | ps            |
| Aperture Uncertainty (Jitter, $t_j$ )                   |        | 55     |        | fs rms        |
| Out of Range Recovery Time                              |        | 1      |        | Clock cycles  |

<sup>1</sup> The junction temperature ( $T_j$ ) range of  $-10^{\circ}\text{C}$  to  $+120^{\circ}\text{C}$  translates to an ambient temperature ( $T_A$ ) range of  $-40^{\circ}\text{C}$  to  $+85^{\circ}\text{C}$ .

<sup>2</sup> The maximum sample rate is the clock rate after the divider.

<sup>3</sup> Baud rate =  $1/\text{UI}$ . A subset of this range can be supported.

<sup>4</sup> Default  $L = 8$ . This number can be changed based on the sample rate and decimation ratio.

<sup>5</sup> No DDCs used.  $L = 8$ ,  $M = 2$ , and  $F = 1$ .

<sup>6</sup> Refer to the Latency section for more details.

TIMING SPECIFICATIONS

Table 5.

| Parameter                                  | Description   | Min | Typ | Max | Unit |
|--|---|-----|-----|-----|------|
| <b>CLK+ to SYSREF+ TIMING REQUIREMENTS</b> |   |     |     |     |      |
| $t_{SU\_SR}$                               | Device clock to SYSREF+ setup time  |     | -65 |     | ps   |
| $t_{H\_SR}$                                | Device clock to SYSREF+ hold time   |     | 95  |     | ps   |
| <b>SPI TIMING REQUIREMENTS</b>             |   |     |     |     |      |
| $t_{DS}$                                   | Setup time between the data and the rising edge of SCLK   | 2   |     |     | ns   |
| $t_{DH}$                                   | Hold time between the data and the rising edge of SCLK  | 2   |     |     | ns   |
| $t_{CLK}$                                  | Period of the SCLK  | 40  |     |     | ns   |
| $t_S$                                      | Setup time between CSB and SCLK   | 2   |     |     | ns   |
| $t_H$                                      | Hold time between CSB and SCLK  | 2   |     |     | ns   |
| $t_{HIGH}$                                 | Minimum period that SCLK must be in a logic high state  | 10  |     |     | ns   |
| $t_{LOW}$                                  | Minimum period that SCLK must be in a logic low state   | 10  |     |     | ns   |
| $t_{ACCESS}$                               | Maximum time delay between the falling edge of SCLK and output data valid for a read operation                                |     | 6   | 10  | ns   |
| $t_{DIS\_SDIO}$                            | Time required for the SDIO pin to switch from an output to an input, relative to the SCLK rising edge (not shown in Figure 4) | 10  |     |     | ns   |

Timing Diagrams

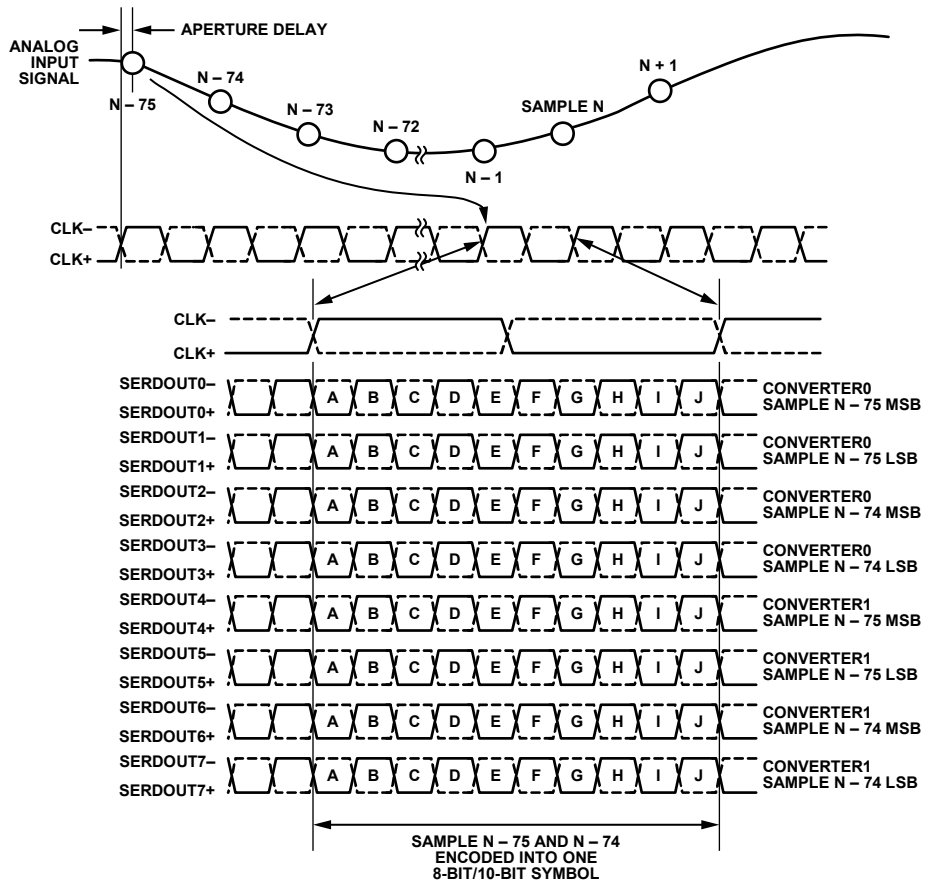

Figure 2. Data Output Timing Diagram

15547-002

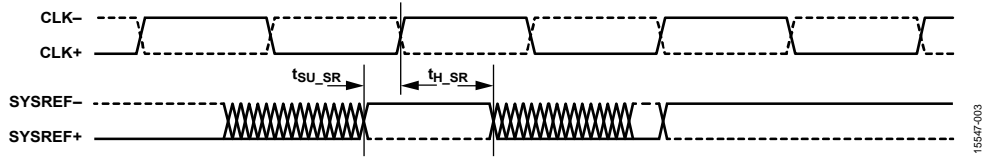

Figure 3. SYSREF± Setup and Hold Timing Diagram

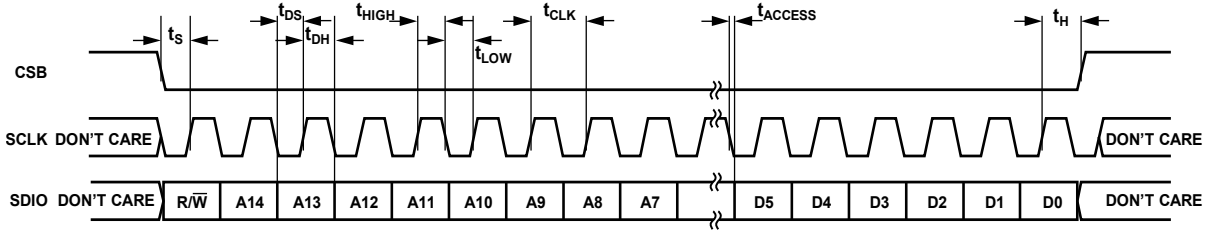

Figure 4. SPI Interface Timing Diagram

## ABSOLUTE MAXIMUM RATINGS

Table 6.

| Parameter  | Rating                         |
|--|--------------------------------|
| Electrical   |                                |
| AVDD1 to AGND  | 1.05 V                         |
| AVDD1_SR to AGND                                     | 1.05 V                         |
| AVDD2 to AGND  | 2.0 V                          |
| AVDD3 to AGND  | 2.70 V                         |
| DVDD to DGND   | 1.05 V                         |
| DRVDD1 to DRGND                                      | 1.05 V                         |
| DRVDD2 to DRGND                                      | 2.0 V                          |
| SPIVDD to DGND                                       | 2.0 V                          |
| AGND to DRGND  | −0.3 V to +0.3 V               |
| AGND to DGND   | −0.3 V to +0.3 V               |
| DGND to DRGND  | −0.3 V to +0.3 V               |
| VIN±x to AGND  | AGND − 0.3 V to AVDD3 + 0.3 V  |
| CLK± to AGND   | AGND − 0.3 V to AVDD1 + 0.3 V  |
| SCLK, SDIO, CSB to DGND                              | DGND − 0.3 V to SPIVDD + 0.3 V |
| PDWN/STBY to DGND                                    | DGND − 0.3 V to SPIVDD + 0.3 V |
| SYSREF± to AGND                                      | 2.5 V                          |
| SYNCINB± to DRGND                                    | 2.5 V                          |
| Junction Temperature Range (T <sub>J</sub> )         | −40°C to +125°C                |
| Storage Temperature Range, Ambient (T <sub>A</sub> ) | −65°C to +150°C                |

Stresses at or above those listed under Absolute Maximum Ratings may cause permanent damage to the product. This is a stress rating only; functional operation of the product at these or any other conditions above those indicated in the operational section of this specification is not implied. Operation beyond the maximum operating conditions for extended periods may affect product reliability.

## THERMAL RESISTANCE

Thermal performance is directly linked to printed circuit board (PCB) design and operating environment. Close attention to PCB thermal design is required.  $\theta_{JA}$  is the natural convection junction-to-ambient thermal resistance measured in a one cubic foot sealed enclosure.  $\theta_{JC}$  is the junction to case thermal resistance.

Table 7. Thermal Resistance

| Package Type          | $\theta_{JA}$ | $\theta_{JC\_TOP}$ | $\Psi_{JB}$ | $\Psi_{JT}$ | Unit |
|-----------------------|---------------|--------------------|-------------|-------------|------|
| BP-196-4 <sup>1</sup> | 16.26         | 1.4                | 5.44        | 1.68        | °C/W |

<sup>1</sup> Test Condition 1: Thermal impedance simulated values are based on JEDEC 2S2P thermal test board with 190 thermal vias. See JEDEC JESD51.

## ESD CAUTION



**ESD (electrostatic discharge) sensitive device.** Charged devices and circuit boards can discharge without detection. Although this product features patented or proprietary protection circuitry, damage may occur on devices subjected to high energy ESD. Therefore, proper ESD precautions should be taken to avoid performance degradation or loss of functionality.

# PIN CONFIGURATION AND FUNCTION DESCRIPTIONS

|   |  | AD9208            |                   |                   |                    |                    |                   |                   |                   |                   |                    |                    |                   |                   |                   |
|---|--|-------------------|-------------------|-------------------|--------------------|--------------------|-------------------|-------------------|-------------------|-------------------|--------------------|--------------------|-------------------|-------------------|-------------------|
|   |  | 1                 | 2                 | 3                 | 4                  | 5                  | 6                 | 7                 | 8                 | 9                 | 10                 | 11                 | 12                | 13                | 14                |
| A |  | AVDD2             | AVDD2             | AVDD1             | AVDD1 <sup>1</sup> | AVDD1 <sup>1</sup> | AGND <sup>1</sup> | CLK+              | CLK-              | AGND <sup>1</sup> | AVDD1 <sup>1</sup> | AVDD1 <sup>1</sup> | AVDD1             | AVDD2             | AVDD2             |
| B |  | AVDD2             | AVDD2             | AVDD1             | AVDD1 <sup>1</sup> | AGND               | AGND <sup>1</sup> | AGND <sup>1</sup> | AGND <sup>1</sup> | AGND <sup>1</sup> | AGND               | AVDD1 <sup>1</sup> | AVDD1             | AVDD2             | AVDD2             |
| C |  | AVDD2             | AVDD2             | AVDD1             | AGND               | AGND               | AGND <sup>1</sup> | AGND <sup>1</sup> | AGND <sup>1</sup> | AGND <sup>1</sup> | AGND               | AGND               | AVDD1             | AVDD2             | AVDD2             |
| D |  | AVDD3             | AGND              | AGND              | AGND               | AGND               | AGND              | AGND <sup>1</sup> | AGND <sup>1</sup> | AGND              | AGND               | AGND               | AGND              | AGND              | AVDD3             |
| E |  | VIN-B             | AGND              | AGND              | AGND               | AGND               | AGND <sup>2</sup> | AVDD1_SR          | AGND <sup>2</sup> | AGND              | AGND               | AGND               | AGND              | AGND              | VIN-A             |
| F |  | VIN+B             | AGND              | AGND              | AGND               | AGND               | AGND              | SYSREF+           | SYSREF-           | AGND              | AGND               | AGND               | AGND              | AGND              | VIN+A             |
| G |  | AVDD3             | AGND              | AGND              | AGND               | AGND               | AGND              | AGND              | AGND              | AGND              | AGND               | AGND               | AGND              | AGND              | AVDD3             |
| H |  | AGND              | AGND              | AGND              | AGND               | AGND               | AGND              | AGND              | AGND              | AGND              | VREF               | AGND               | AGND              | AGND              | AGND              |
| J |  | AGND              | AGND              | AGND              | AGND               | AGND               | AGND              | AGND              | AGND              | AGND              | AGND               | AGND               | AGND              | AGND              | AGND              |
| K |  | AGND <sup>3</sup> | AGND <sup>3</sup> | AGND <sup>3</sup> | AGND <sup>3</sup>  | AGND <sup>3</sup>  | AGND <sup>3</sup> | AGND <sup>3</sup> | AGND <sup>3</sup> | AGND <sup>3</sup> | AGND <sup>3</sup>  | AGND <sup>3</sup>  | AGND <sup>3</sup> | AGND <sup>3</sup> | AGND <sup>3</sup> |
| L |  | DGND              | GPIO_B1           | SPIVDD            | FD_B/<br>GPIO_B0   | CSB                | SCLK              | SDIO              | PDWN/<br>STBY     | FD_A/<br>GPIO_A0  | SPIVDD             | GPIO_A1            | DGND              | DGND              | DGND              |
| M |  | DGND              | DGND              | DRGND             | DRGND              | DRVDD1             | DRVDD1            | DRVDD1            | DRVDD1            | DRGND             | DRGND              | DRVDD1             | DRGND             | DRVDD2            | DVDD              |
| N |  | DVDD              | DVDD              | DRGND             | SERDOUT+           | SERDOUT6+          | SERDOUT5+         | SERDOUT4+         | SERDOUT3+         | SERDOUT2+         | SERDOUT1+          | SERDOUT0+          | DRGND             | SYNCINB+          | DVDD              |
| P |  | DVDD              | DVDD              | DRGND             | SERDOUT-           | SERDOUT6-          | SERDOUT5-         | SERDOUT4-         | SERDOUT3-         | SERDOUT2-         | SERDOUT1-          | SERDOUT0-          | DRGND             | SYNCINB-          | DVDD              |

<sup>1</sup>DENOTES CLOCK DOMAIN.  
<sup>2</sup>DENOTES SYSREF± DOMAIN.  
<sup>3</sup>DENOTES ISOLATION DOMAIN.

Figure 5. Pin Configuration (Top View)

15547-005

Table 8. Pin Function Descriptions<sup>1</sup>

| Pin No.  | Mnemonic             | Type         | Description   |
|--|----------------------|--------------|---|
| Power Supplies   |                      |              |   |
| A3, A12, B3, B12, C3, C12  | AVDD1                | Power        | Analog Power Supply (0.975 V Nominal).  |
| A4, A5, A10, A11, B4, B11  | AVDD1 <sup>2</sup>   | Power        | Analog Power Supply for the Clock Domain (0.975 V Nominal).   |
| A1, A2, A13, A14, B1, B2, B13, B14, C1, C2, C13, C14   | AVDD2                | Power        | Analog Power Supply (1.9 V Nominal).  |
| D1, D14, G1, G14   | AVDD3                | Power        | Analog Power Supply (2.5 V Nominal).  |
| E7   | AVDD1_SR             | Power        | Analog Power Supply for SYSREF± (0.975 V Nominal).  |
| L3, L10  | SPIVDD               | Power        | Digital Power Supply for SPI (1.9 V Nominal).   |
| M14, N1, N2, N14, P1, P2, P14  | DVDD                 | Power        | Digital Power Supply (0.975 V Nominal).   |
| M5 to M8, M11  | DRVDD1               | Power        | Digital Driver Power Supply (0.975 V Nominal).  |
| M13  | DRVDD2               | Power        | Digital Driver Power Supply (1.9 V Nominal).  |
| B5, B10, C4, C5, C10, C11, D2 to D6, D9 to D13, E2 to E5, E9 to E13, F2 to F6, F9 to F13, G2 to G13, H1 to H9, H11 to H14, J1 to J14 | AGND                 | Ground       | Analog Ground. These pins connect to the analog ground plane.   |
| A6, A9, B6 to B9, C6 to C9, D7, D8   | AGND <sup>2</sup>    | Ground       | Ground Reference for the Clock Domain.  |
| E6, E8   | AGND <sup>3</sup>    | Ground       | Ground Reference for SYSREF±.   |
| K1 to K14  | AGND <sup>4</sup>    | Ground       | Isolation Ground.   |
| L1, L12 to L14, M1, M2   | DGND                 | Ground       | Digital Control Ground Supply. These pins connect to the digital ground plane.  |
| M3, M4, M9, M10, M12, N3, N12, P3, P12   | DRGND                | Ground       | Digital Driver Ground Supply. These pins connect to the digital driver ground plane.  |
| Analog   |                      |              |   |
| E1, F1   | VIN–B, VIN+B         | Input        | ADC B Analog Input Complement/True.   |
| E14, F14   | VIN–A, VIN+A         | Input        | ADC A Analog Input Complement/True.   |
| A7, A8   | CLK+, CLK–           | Input        | Clock Input True/Complement.  |
| H10  | VREF                 | Input/DNC    | 0.50 V Reference Voltage Input/Do Not Connect. This pin is configurable through the SPI as a no connect or an input. Do not connect this pin if using the internal reference. This pin requires a 0.50 V reference voltage input if using an external voltage reference source. |
| CMOS Inputs/Outputs  |                      |              |   |
| L2   | GPIO_B1              | Input/output | GPIO B1.  |
| L4   | FD_B/GPIO_B0         | Input/output | Fast Detect Outputs for Channel B/GPIO B0.  |
| L9   | FD_A/GPIO_A0         | Input/output | Fast Detect Outputs for Channel A/GPIO A0.  |
| L11  | GPIO_A1              | Input/output | GPIO A1.  |
| Digital Inputs   |                      |              |   |
| F7, F8   | SYSREF+, SYSREF–     | Input        | Active High JESD204B LVDS System Reference Input True/Complement.   |
| N13  | SYNCINB+             | Input        | Active Low JESD204B LVDS/CMOS Sync Input True.  |
| P13  | SYNCINB–             | Input        | Active Low JESD204B LVDS Sync Input Complement.   |
| Data Outputs   |                      |              |   |
| N4, P4   | SERDOUT7+, SERDOUT7– | Output       | Lane 7 Output Data True/Complement.   |
| N5, P5   | SERDOUT6+, SERDOUT6– | Output       | Lane 6 Output Data True/Complement.   |
| N6, P6   | SERDOUT5+, SERDOUT5– | Output       | Lane 5 Output Data True/Complement.   |
| N7, P7   | SERDOUT4+, SERDOUT4– | Output       | Lane 4 Output Data True/Complement.   |
| N8, P8   | SERDOUT3+, SERDOUT3– | Output       | Lane 3 Output Data True/Complement.   |
| N9, P9   | SERDOUT2+, SERDOUT2– | Output       | Lane 2 Output Data True/Complement.   |
| N10, P10   | SERDOUT1+, SERDOUT1– | Output       | Lane 1 Output Data True/Complement.   |
| N11, P11   | SERDOUT0+, SERDOUT0– | Output       | Lane 0 Output Data True/Complement.   |

| Pin No.          | Mnemonic  | Type         | Description   |
|------------------|-----------|--------------|---|
| Digital Controls |           |              |   |
| L8               | PDWN/STBY | Input        | Power-Down Input (Active High). The operation of this pin depends on the SPI mode and can be configured as power-down or standby. |
| L5               | CSB       | Input        | SPI Chip Select (Active Low).   |
| L6               | SCLK      | Input        | SPI Serial Clock.   |
| L7               | SDIO      | Input/output | SPI Serial Data Input/Output.   |

<sup>1</sup> See the Theory of Operation section and the Applications Information section for more information on isolating the planes for optimal performance.

<sup>2</sup> Denotes clock domain.

<sup>3</sup> Denotes SYSREF± domain.

<sup>4</sup> Denotes isolation domain.

## TYPICAL PERFORMANCE CHARACTERISTICS

AVDD1 = 0.975 V, AVDD1\_SR = 0.975 V, AVDD2 = 1.9 V, AVDD3 = 2.5 V, DVDD = 0.975 V, DRVDD1 = 0.975 V, DRVDD2 = 1.9 V, SPIVDD = 1.9 V, sampling rate = 3000 MHz, 1.7 V p-p full-scale differential input, DDC decimation rate = 8, default buffer current settings, T<sub>A</sub> = 25°C, 128,000 fast Fourier transform (FFT) sample, unless otherwise noted. See Table 10 for the recommended settings.

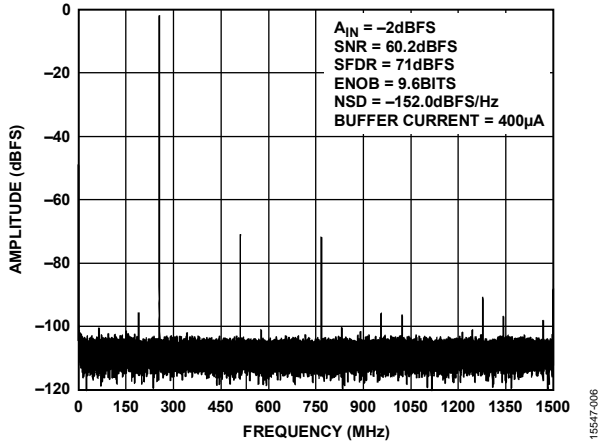

Figure 6. Single-Tone FFT at  $f_{IN} = 255$  MHz

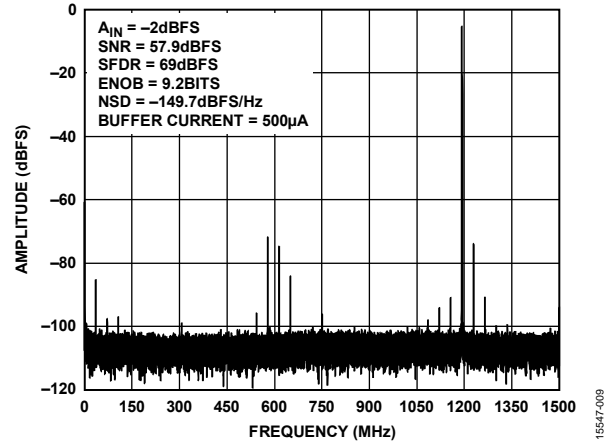

Figure 9. Single-Tone FFT at  $f_{IN} = 1807$  MHz

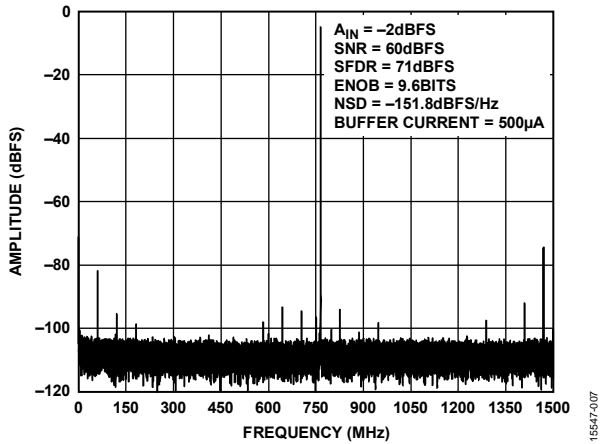

Figure 7. Single-Tone FFT at  $f_{IN} = 765$  MHz

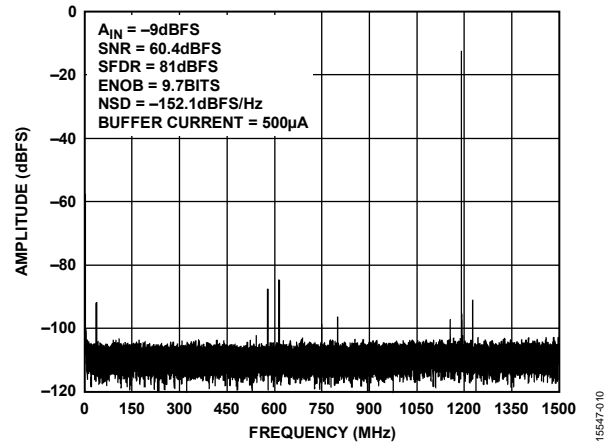

Figure 10. Single-Tone FFT at  $f_{IN} = 1807$  MHz,  $A_{IN} = -9$  dBFS

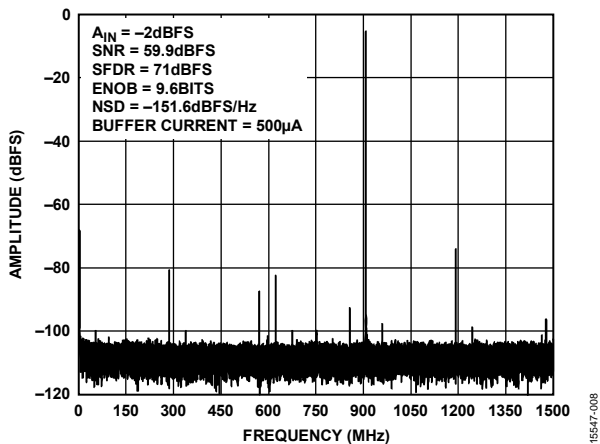

Figure 8. Single-Tone FFT at  $f_{IN} = 905$  MHz

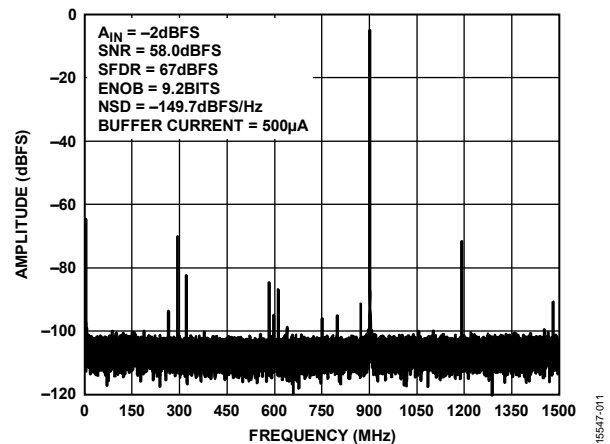

Figure 11. Single-Tone FFT at  $f_{IN} = 2100$  MHz



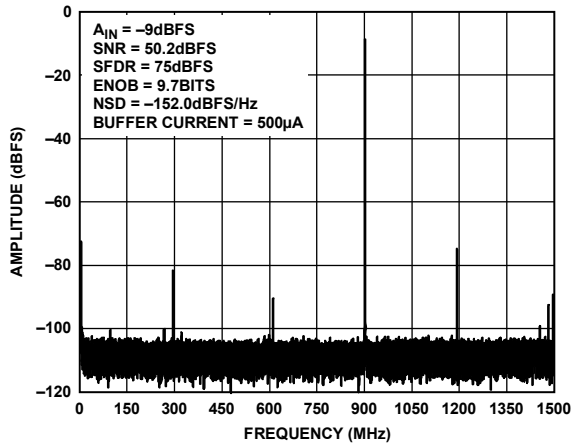

Figure 12. Single-Tone FFT at  $f_{IN} = 2100$  MHz,  $A_{IN} = -9$  dBFS

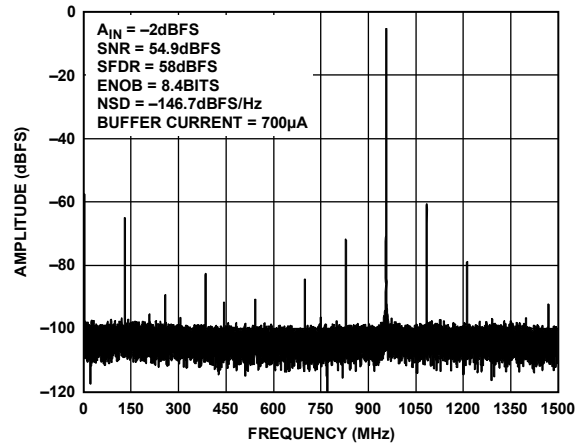

Figure 15. Single-Tone FFT at  $f_{IN} = 3957$  MHz

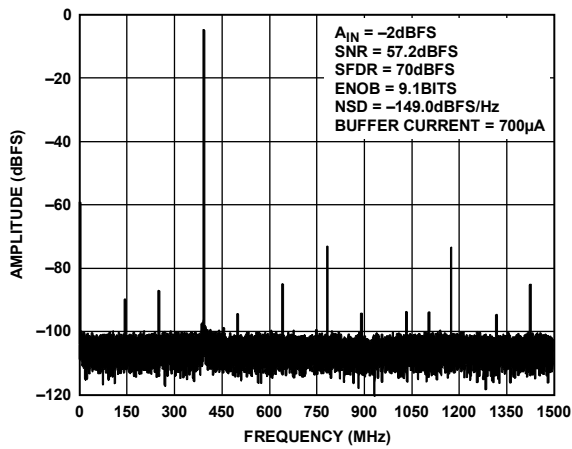

Figure 13. Single-Tone FFT at  $f_{IN} = 2600$  MHz

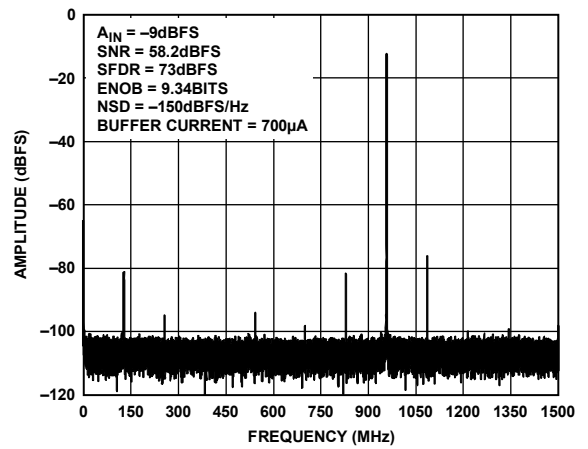

Figure 16. Single-Tone FFT at  $f_{IN} = 3957$  MHz,  $A_{IN} = -9$  dBFS

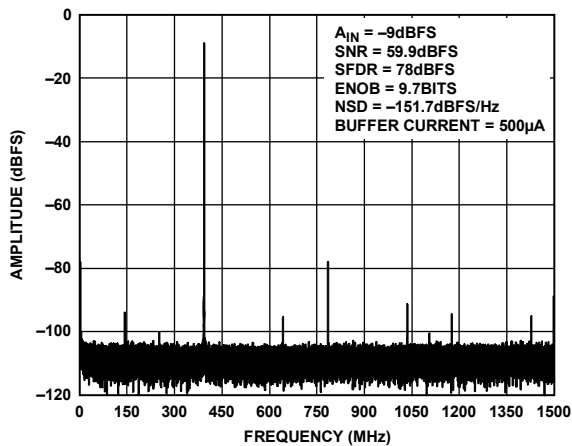

Figure 14. Single-Tone FFT at  $f_{IN} = 2600$  MHz,  $A_{IN} = -9$  dBFS

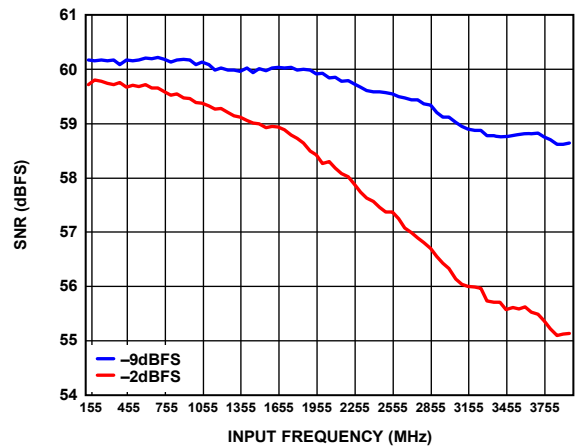

Figure 17. SNR vs. Input Frequency ( $f_{IN}$ );  $A_{IN} = -2$  dBFS and  $-9$  dBFS

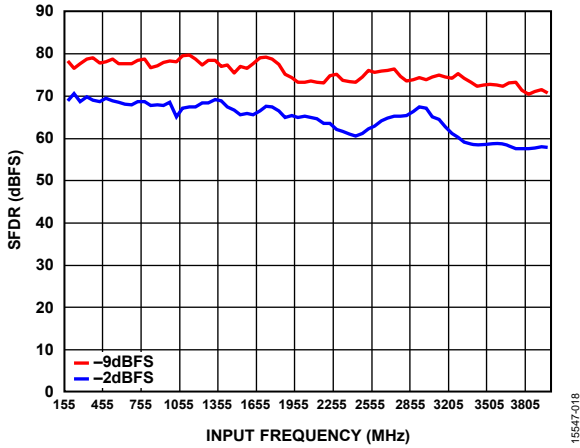

Figure 18. SFDR vs. Input Frequency ( $f_{IN}$ );  $A_{IN} = -2$  dBFS and  $-9$  dBFS

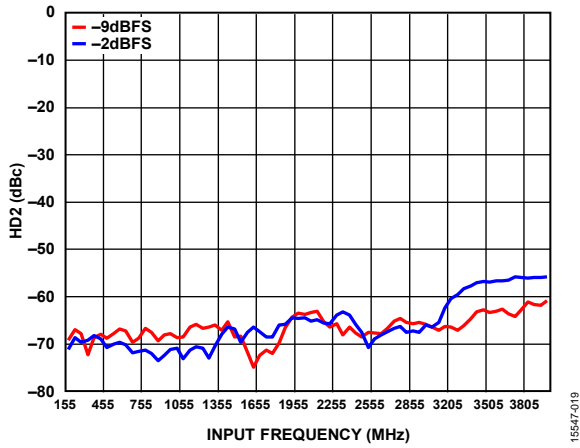

Figure 19. HD2 vs. Input Frequency ( $f_{IN}$ );  $A_{IN} = -2$  dBFS and  $-9$  dBFS

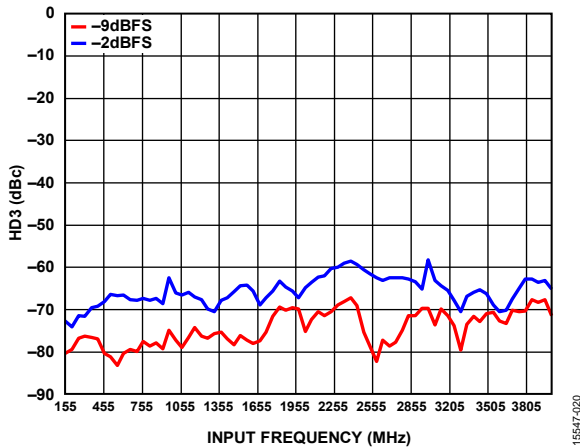

Figure 20. HD3 vs. Input Frequency ( $f_{IN}$ );  $A_{IN} = -2$  dBFS and  $-9$  dBFS

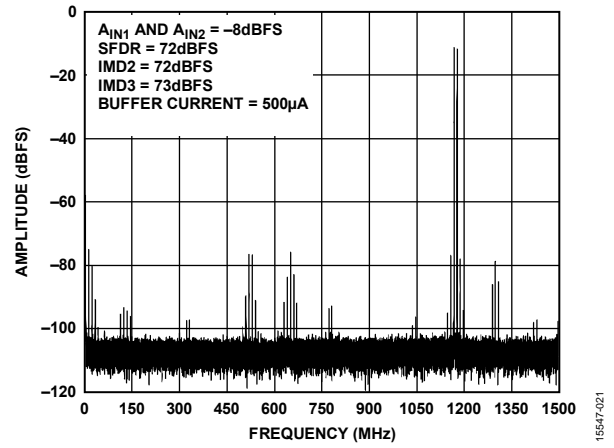

Figure 21. Two-Tone FFT;  $f_{IN1} = 1821.5$  MHz,  $f_{IN2} = 1831.5$  MHz;  $A_{IN1}$  and  $A_{IN2} = -8$  dBFS

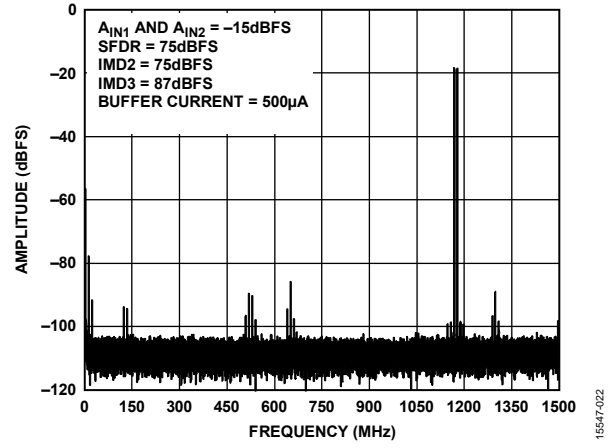

Figure 22. Two-Tone FFT;  $f_{IN1} = 1821.5$  MHz,  $f_{IN2} = 1831.5$  MHz;  $A_{IN1}$  and  $A_{IN2} = -15$  dBFS

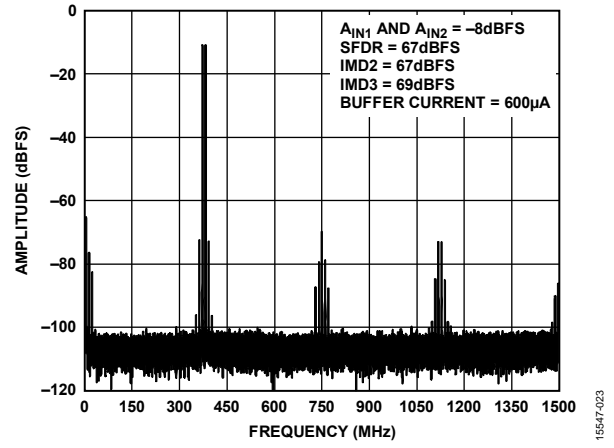

Figure 23. Two-Tone FFT;  $f_{IN1} = 2621.5$  MHz,  $f_{IN2} = 2631.5$  MHz;  $A_{IN1}$  and  $A_{IN2} = -8$  dBFS

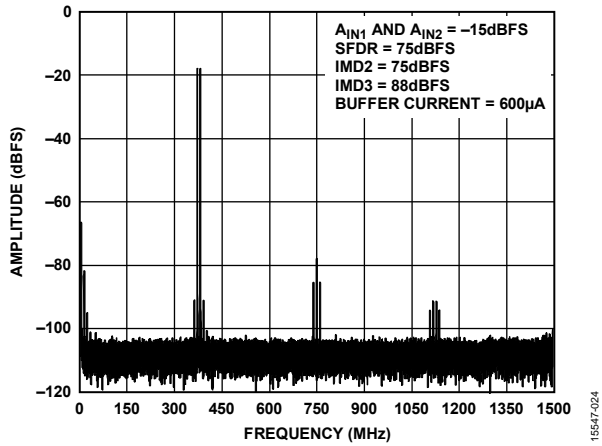

Figure 24. Two-Tone FFT;  $f_{IN1} = 2621.5$  MHz,  $f_{IN2} = 2631.5$  MHz;  $A_{IN1}$  and  $A_{IN2} = -15$  dBFS

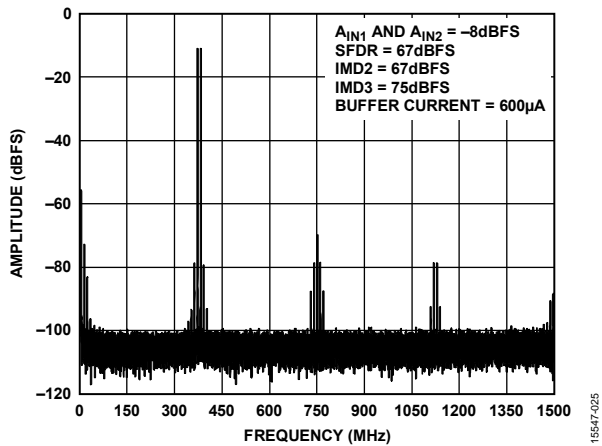

Figure 25. Two-Tone FFT;  $f_{IN1} = 2621.5$  MHz,  $f_{IN2} = 2631.5$  MHz; Full-Scale Voltage = 1.1 V p-p;  $A_{IN1}$  and  $A_{IN2} = -8$  dBFS

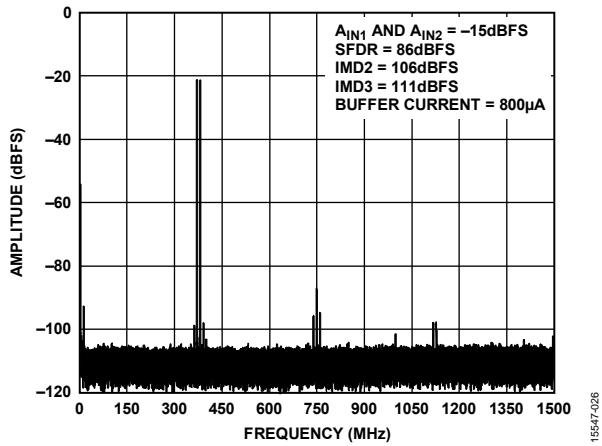

Figure 26. Two-Tone FFT;  $f_{IN1} = 2621.5$  MHz,  $f_{IN2} = 2631.5$  MHz; Full-Scale Voltage = 1.1 V p-p;  $A_{IN1}$  and  $A_{IN2} = -15$  dBFS

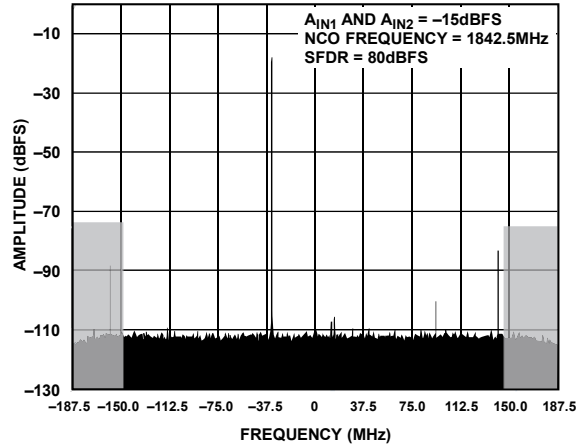

Figure 27. Two-Tone FFT;  $f_{IN1} = 1800$  MHz,  $f_{IN2} = 2100$  MHz  $f_{CLK} = 2.94912$  GHz; Decimation Ratio = 8, NCO Frequency = 1874.28 MHz

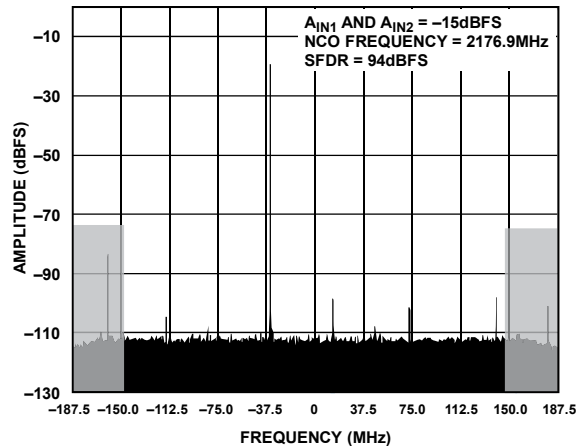

Figure 28. Two-Tone FFT;  $f_{IN1} = 1800$  MHz,  $f_{IN2} = 2100$  MHz  $f_{CLK} = 2.94912$  GHz; Decimation Ratio = 8, NCO Frequency = 2176.92 MHz

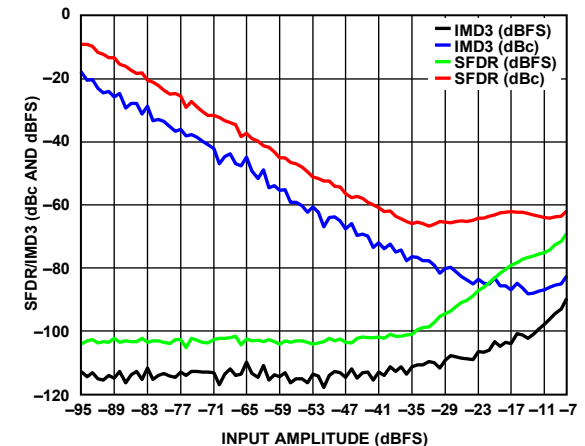

Figure 29. Two-Tone SFDR/IMD3 vs. Input Amplitude ( $A_{IN}$ ) with  $f_{IN1} = 1821.5$  MHz,  $f_{IN2} = 1831.5$  MHz

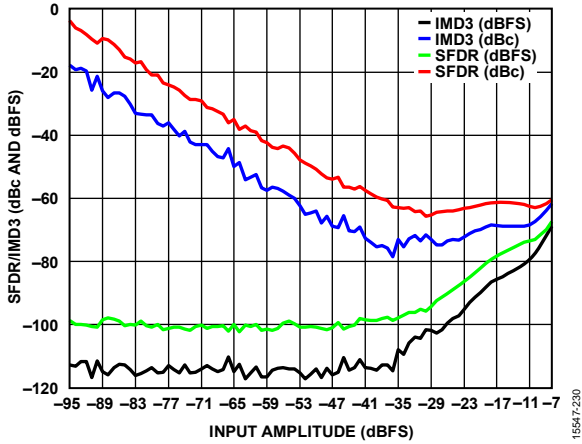

Figure 30. Two-Tone SFDR/IMD3 vs. Input Amplitude ( $A_{IN}$ ) with  $f_{IN1} = 2621.5$  MHz,  $f_{IN2} = 2631.5$  MHz

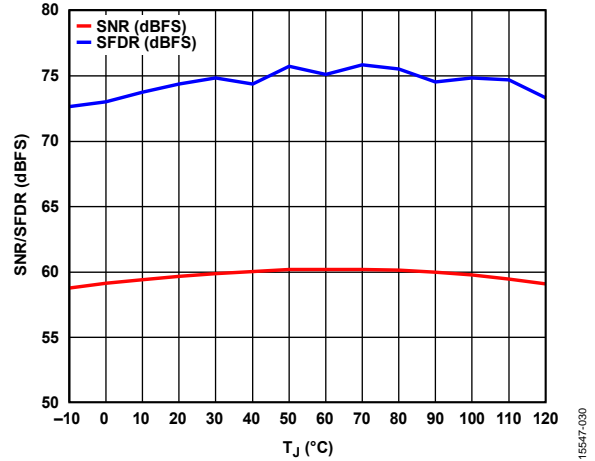

Figure 33. SNR/SFDR vs. Junction Temperature ( $T_J$ ),  $f_{IN} = 950$  MHz,  $A_{IN} = -9$  dBFS

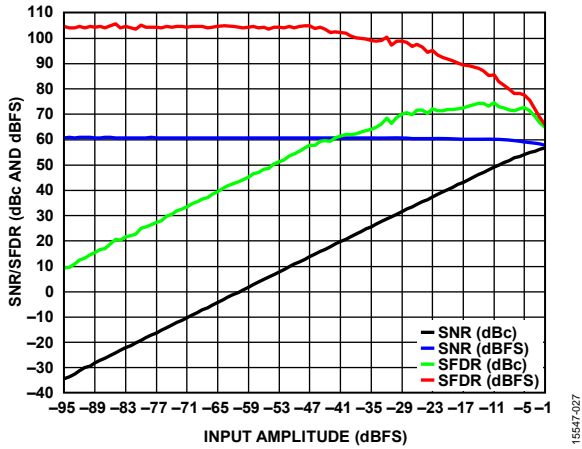

Figure 31. SNR/SFDR vs. Input Amplitude ( $A_{IN}$ ),  $f_{IN} = 950$  MHz

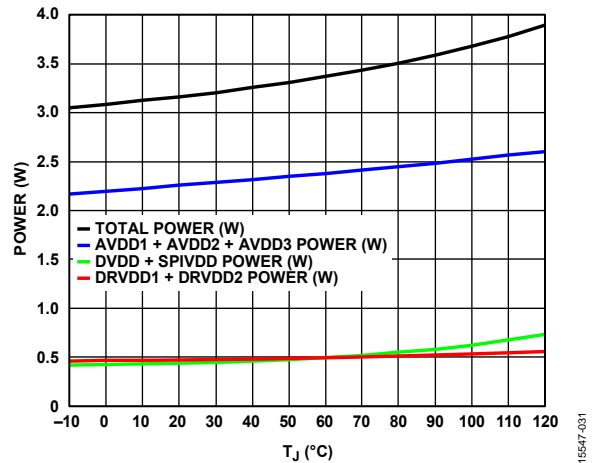

Figure 34. Power vs. Junction Temperature ( $T_J$ ),  $f_{IN} = 950$  MHz

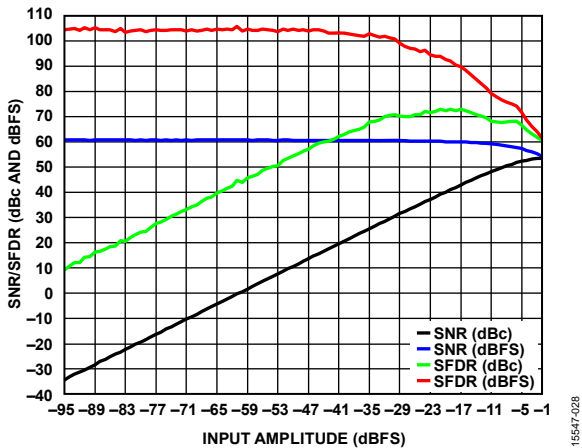

Figure 32. SNR/SFDR vs. Input Amplitude ( $A_{IN}$ ),  $f_{IN} = 1800$  MHz

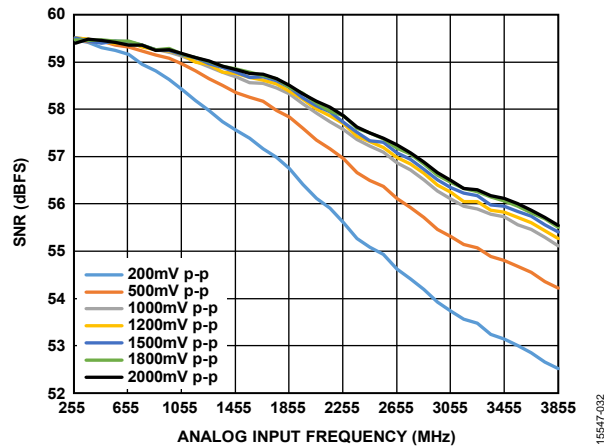

Figure 35. SNR vs. Analog Input Frequency ( $f_{IN}$ ) vs. Various Clock Amplitude in Differential Voltages,  $A_{IN} = -2$  dBFS

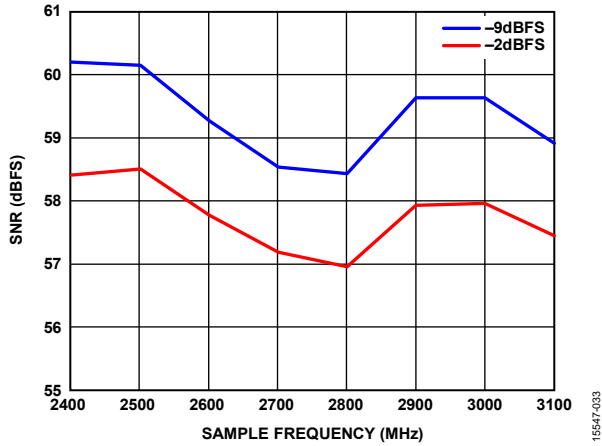

Figure 36. SNR vs. Sample Frequency ( $f_s$ ),  $f_{IN} = 1.8$  GHz;  $A_{IN} = -2$  dBFS and  $-9$  dBFS

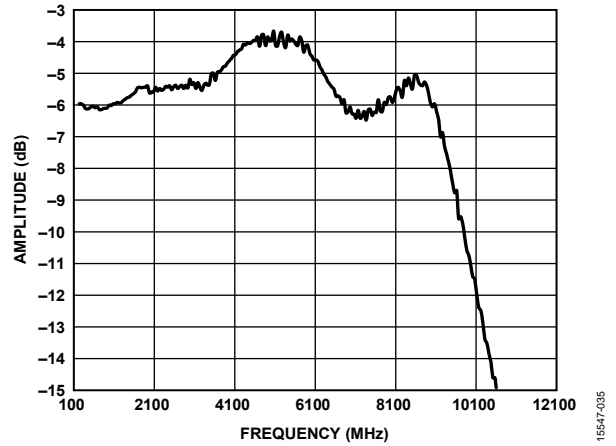

Figure 39. Input Bandwidth (See Figure 55 for the Input Configuration)

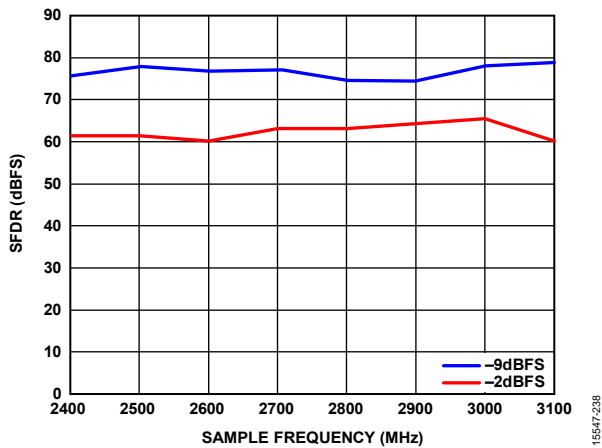

Figure 37. SFDR vs. Sample Frequency ( $f_s$ ),  $f_{IN} = 1.8$  GHz;  $A_{IN} = -2$  dBFS and  $-9$  dBFS

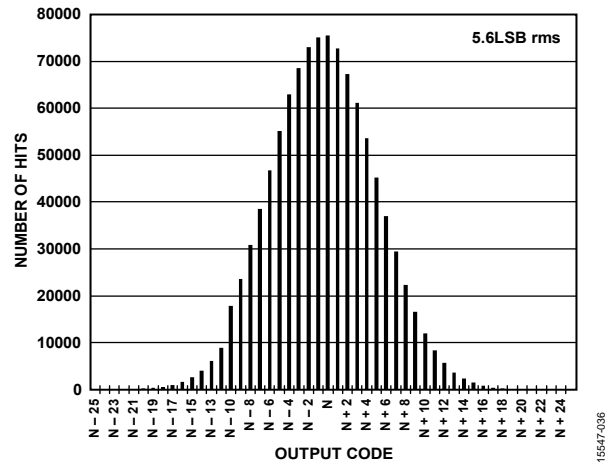

Figure 40. Input Referred Noise Histogram

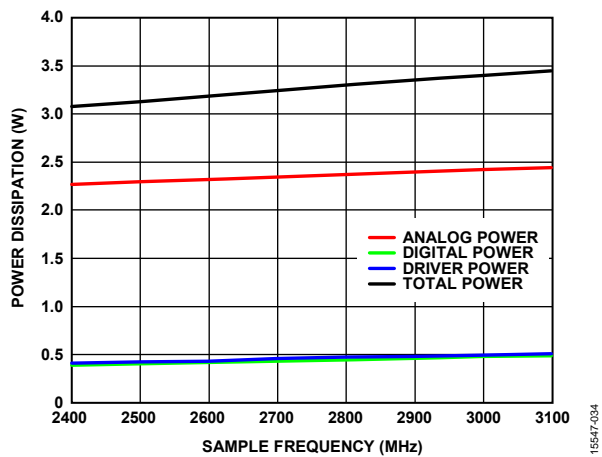

Figure 38. Power Dissipation vs. Sample Frequency ( $f_s$ ),  $f_{IN} = 1.8$  GHz;  $A_{IN} = -2$  dBFS

EQUIVALENT CIRCUITS

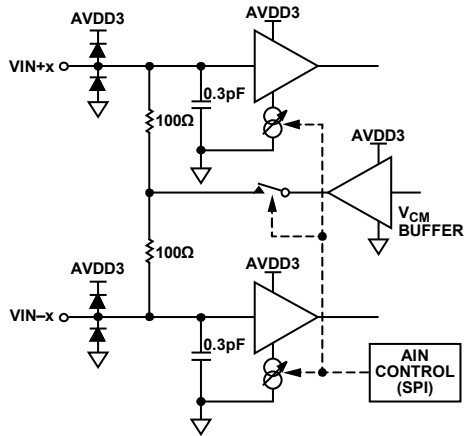

Figure 41. Analog Inputs

15547-037

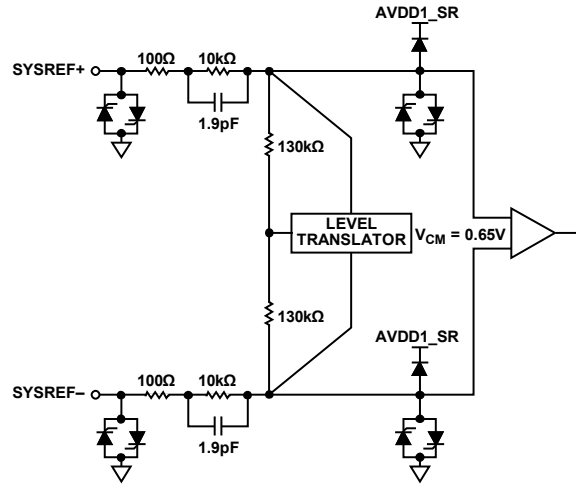

Figure 43. SYSREF± Inputs

15547-039

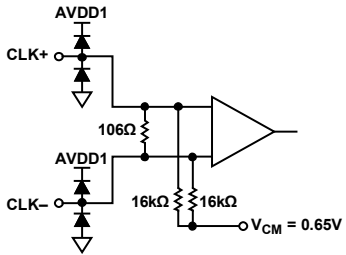

Figure 42. Clock Inputs

15547-038

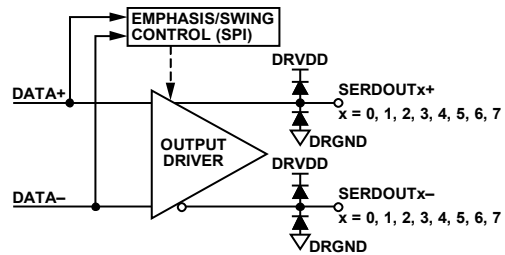

Figure 44. Digital Outputs

15547-040

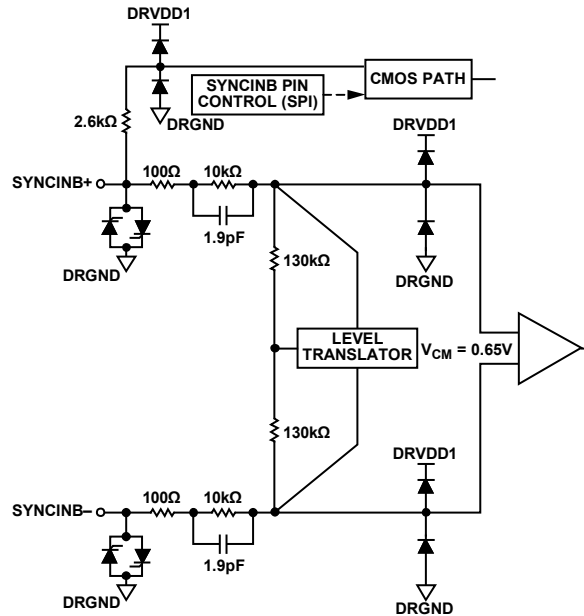

Figure 45. SYNCIN± Inputs

15547-041

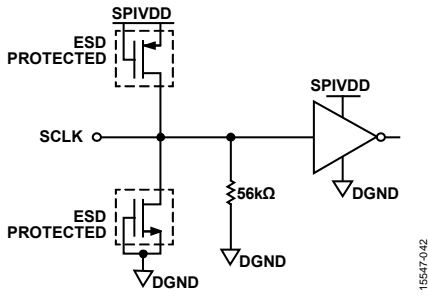

Figure 46. SCLK Input

15547-042

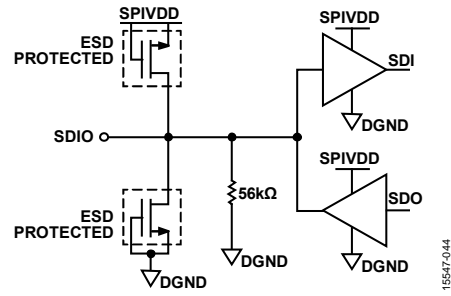

Figure 48. SDIO Input

15547-044

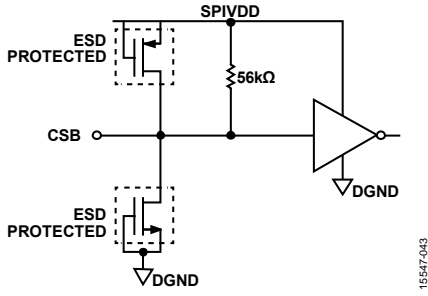

Figure 47. CSB Input

15547-043

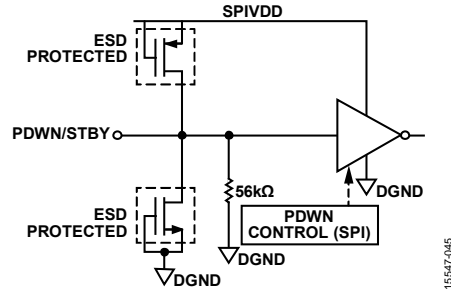

Figure 49. PDWN/STBY Input

15547-045

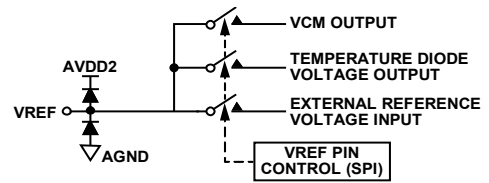

Figure 50. VREF Input/Output

15547-046

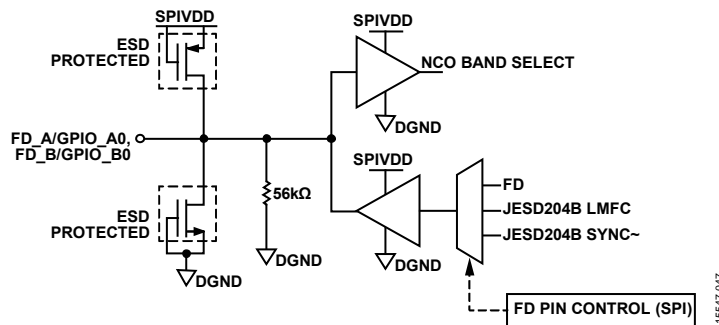

Figure 51. FD\_A/GPIO\_A0, FD\_B/GPIO\_B0

15547-047

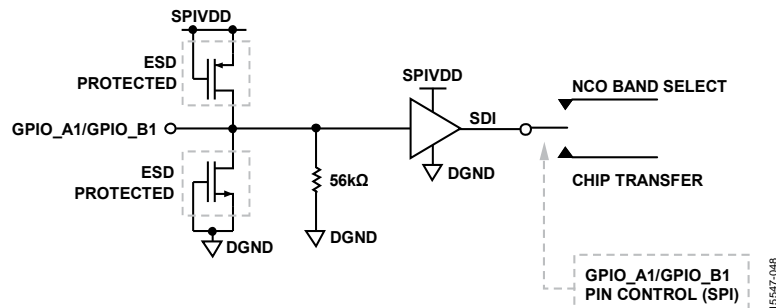

Figure 52. GPIO\_A1/GPIO\_B1

15547-048

## THEORY OF OPERATION

The AD9208 has two analog input channels and up to eight JESD204B output lane pairs. The ADC samples wide bandwidth analog signals of up to 5 GHz. The actual  $-3$  dB roll-off of the analog inputs is 9 GHz. The AD9208 is optimized for wide input bandwidth, high sampling rate, excellent linearity, and low power in a small package.

The dual ADC cores feature a multistage, differential pipelined architecture with integrated output error correction logic. Each ADC features wide bandwidth inputs supporting a variety of user-selectable input ranges. An integrated voltage reference eases design considerations.

The AD9208 has several functions that simplify the AGC function in a communications receiver. The programmable threshold detector allows monitoring of the incoming signal power using the fast detect output bits of the ADC. If the input signal level exceeds the programmable threshold, the fast detect indicator goes high. Because this threshold indicator has low latency, the user can quickly turn down the system gain to avoid an overrange condition at the ADC input.

The Subclass 1 JESD204B-based high speed serialized output data lanes can be configured in one-lane ( $L = 1$ ), two-lane ( $L = 2$ ), four-lane ( $L = 4$ ), and eight-lane ( $L = 8$ ) configurations, depending on the sample rate and the decimation ratio. Multiple device synchronization is supported through the SYSREF $\pm$  and SYNCINB $\pm$  input pins. The SYSREF $\pm$  pin in the AD9208 can also be used as a timestamp of data as it passes through the ADC and out of the JESD204B interface.

## ADC ARCHITECTURE

The architecture of the AD9208 consists of an input buffered pipelined ADC. The input buffer provides a termination impedance to the analog input signal. This termination impedance is set to 200  $\Omega$ . The equivalent circuit diagram of the analog input termination is shown in Figure 29. The input buffer is optimized for high linearity, low noise, and low power across a wide bandwidth.

The input buffer provides a linear high input impedance (for ease of drive) and reduces kickback from the ADC. The quantized outputs from each stage are combined into a final 14-bit result in the digital correction logic. The pipelined architecture permits the first stage to operate with a new input sample; at the same time, the remaining stages operate with the preceding samples. Sampling occurs on the rising edge of the clock.

## ANALOG INPUT CONSIDERATIONS

The analog input to the AD9208 is a differential buffer. The internal common-mode voltage of the buffer is 1.35 V. The clock signal alternately switches the input circuit between sample mode and hold mode.

Either a differential capacitor or two single-ended capacitors (or a combination of both) can be placed on the inputs to provide a matching passive network. These capacitors ultimately create a low-pass filter that limits unwanted broadband noise. For more information, refer to the *Analog Dialogue* article “[Transformer-Coupled Front-End for Wideband A/D Converters](#)” (Volume 39, April 2005). In general, the precise front-end network component values depend on the application.

Figure 53 shows the differential input return loss curve for the analog inputs across a frequency range of 100 MHz to 10 GHz. The reference impedance is 100  $\Omega$ .

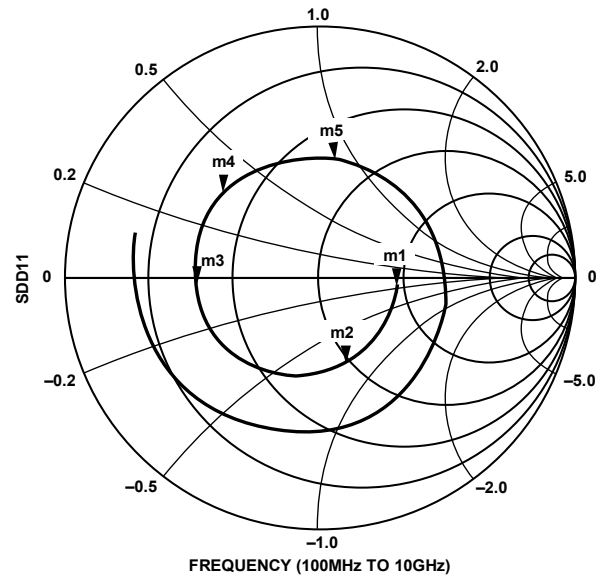

|  |  |
|--|--|
| m1<br>FREQUENCY = 100MHz<br>SDD11 = 0.301/-8.069<br>IMPEDANCE= Z0 * (1.838 - j0.171) | m4<br>FREQUENCY = 4GHz<br>SDD11 = 0.500/136.667<br>IMPEDANCE = Z0 * (0.379 - j0.347) |
| m2<br>FREQUENCY = 1GHz<br>SDD11 = 0.352/-73.534<br>IMPEDANCE= Z0 * (0.947 - j0.731)  | m5<br>FREQUENCY = 5GHz<br>SDD11 = 0.475/79.360<br>IMPEDANCE= Z0 * (0.737 - j0.889)   |
| m3<br>FREQUENCY = 3GHz<br>SDD11 = 0.496/175.045<br>IMPEDANCE= Z0 * (0.337 - j0.038)  |  |

Figure 53. Differential Input Return Loss

For best dynamic performance, the source impedances driving VIN+x and VIN-x must be matched such that common-mode settling errors are symmetrical. These errors are reduced by the common-mode rejection of the ADC. An internal reference buffer creates a differential reference that defines the span of the ADC core.

Maximum SNR performance is achieved by setting the ADC to the largest span in a differential configuration. For the AD9208, the available span is programmable through the SPI port from 1.13 V p-p to 2.04 V p-p differential, with 1.7 V p-p differential being the default.



**Differential Input Configurations**

There are several ways to drive the AD9208, either actively or passively. Optimum performance is achieved by driving the analog input differentially.

For applications where SNR and SFDR are key parameters, differential transformer coupling is the recommended input configuration (see Figure 54 and Table 9) because the noise performance of most amplifiers is not adequate to achieve the true performance of the AD9208.

For low to midrange frequencies, a double balun or double transformer network (see Figure 54 and Table 9) is recommended for optimum performance of the AD9208. For higher frequencies

in the second or third Nyquist zones, it is recommended to remove some of the front-end passive components to ensure wideband operation (see Figure 55 and Table 9).

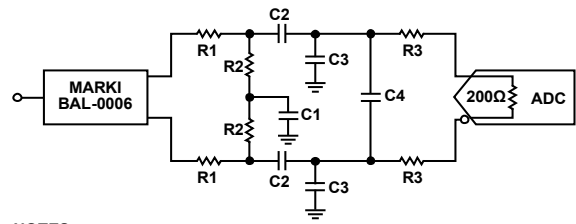

NOTES:  
1. SEE TABLE 9 FOR COMPONENT VALUES

Figure 54. Differential Transformer Coupled Configuration for the AD9208

15547-060

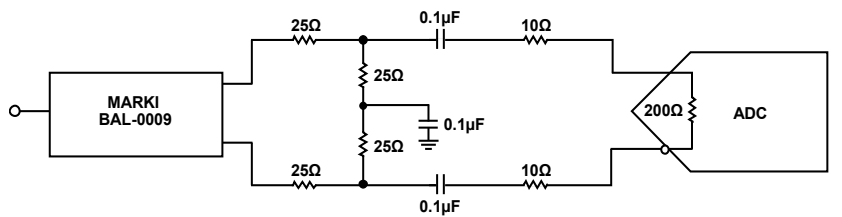

Figure 55. Input Network Configuration for Frequencies > 5 GHz

15547-331

**Table 9. Differential Transformer-Coupled Input Configuration Component Values**

| Frequency Range | Transformer | R1   | R2   | R3   | C1     | C2     | C3     | C4     |
|-----------------|-------------|------|------|------|--------|--------|--------|--------|
| <5000 MHz       | BAL-0006    | 25 Ω | 25 Ω | 10 Ω | 0.1 μF | 0.1 μF | 0.4 pF | 0.4 pF |

### Input Common Mode

The analog inputs of the AD9208 are internally biased to the common-mode voltage, as shown in Figure 57. The common-mode buffer has a limited range in that the performance suffers greatly if the common-mode voltage drops by more than 50 mV on either side of the nominal value.

For dc-coupled applications, the recommended operation procedure is to export the common-mode voltage to the VREF pin using the SPI writes listed in this section. The common-mode voltage must be set by the exported value to ensure proper ADC operation. Disconnect the internal common-mode buffer from the analog input using Register 0x1908.

When performing SPI writes for dc coupling operation, use the following register settings in order:

8. Set Register 0x1908, Bit 2 to disconnect the internal common-mode buffer from the analog input. Note that this is a local register.
9. Set Register 0x18A6 to 0x00 to turn off the voltage reference.

10. Set Register 0x18E6 to 0x00 to turn off the temperature diode export.
11. Set Register 0x18E3, Bit 6 to 1 to turn on the  $V_{CM}$  export.
12. Set Register 0x18E3, Bits[5:0] to the buffer current setting (Register 0x1A4C and Register 0x1A4D) to improve the accuracy of the common-mode export.

Figure 56 shows the block diagram representation of a dc-coupled application.

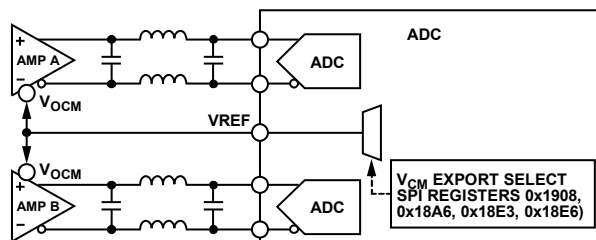

Figure 56. DC-Coupled Application Using the AD9208

15547-051

**Analog Input Buffer Controls and SFDR Optimization**

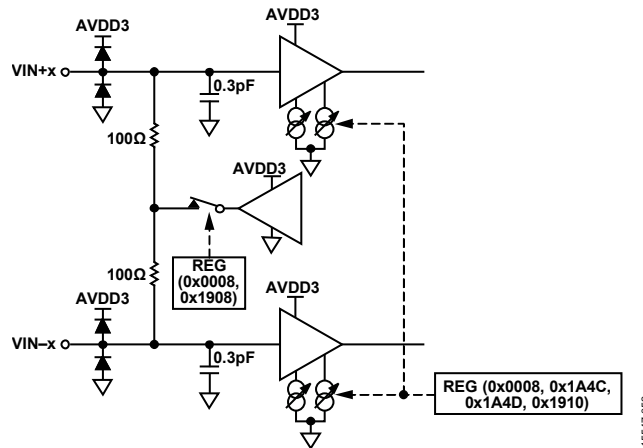

Figure 57. Analog Input Controls

The AD9208 input buffer offers flexible controls for the analog inputs, such as buffer current, dc coupling, and input full-scale adjustment. All the available controls are shown in Figure 57.

Using Register 0x1A4C and Register 0x1A4D, the buffer behavior on each channel can be adjusted to optimize the SFDR over various input frequencies and bandwidths of interest. Use Register 0x1910 to change the internal reference voltage. Changing the internal reference voltage results in a change in the input full-scale voltage.

When the input buffer current in Register 0x1A4C and Register 0x1A4D is set, the amount of current required by the AVDD3 supply changes. This relationship is shown in Figure 58. For a complete list of buffer current settings, see Table 46.

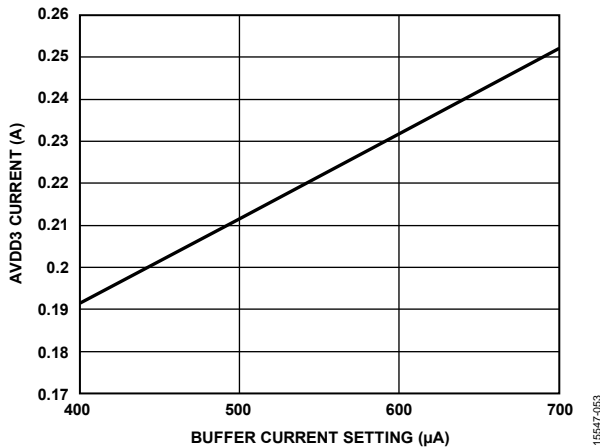

Figure 58. AVDD3 Current ( $I_{AVDD3}$ ) vs. Buffer Current Setting (Buffer Control 1 Setting in Register 0x1A4C and Buffer Control 2 Setting in Register 0x1A4D)

Table 10 shows the recommended values for the buffer current for various Nyquist zones.

**Table 10. SFDR Optimization for Input Frequencies**

| Frequency            | Register 0x1A4C and Register 0x1A4D |
|----------------------|-------------------------------------|
| DC to 1500 MHz       | 400 μA/500 μA                       |
| 1500 MHz to 3000 MHz | 500 μA                              |
| >3000 MHz            | 500 μA/700 μA                       |

**Dither**

The AD9208 has internal on-chip dither circuitry that improves the ADC linearity and SFDR, particularly at smaller signal levels. A known but random amount of white noise is injected into the input of the AD9208. This dither improves the small signal linearity within the ADC transfer function and is precisely subtracted out digitally. The dither is turned on by default and does not reduce the ADC input dynamic range. The data sheet specifications and limits are obtained with the dither turned on.

The dither is on by default. It is not recommended to turn it off.

**Absolute Maximum Input Swing**

The absolute maximum input swing allowed at the inputs of the AD9208 is 5.8 V p-p differential. Signals operating near or at this level can cause permanent damage to the ADC. See Table 6 for more information.

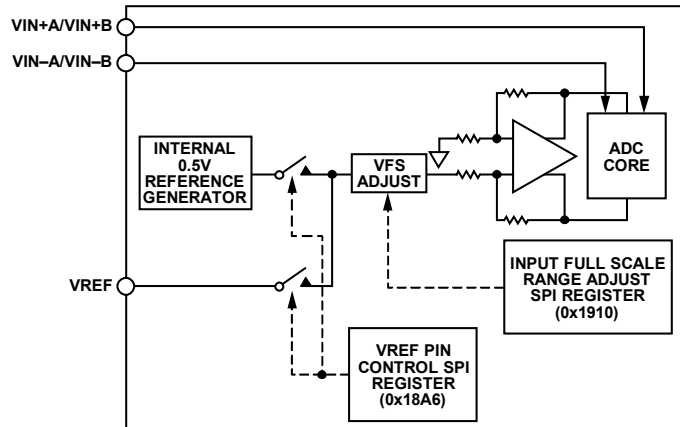

Figure 59. Internal Reference Configuration and Controls

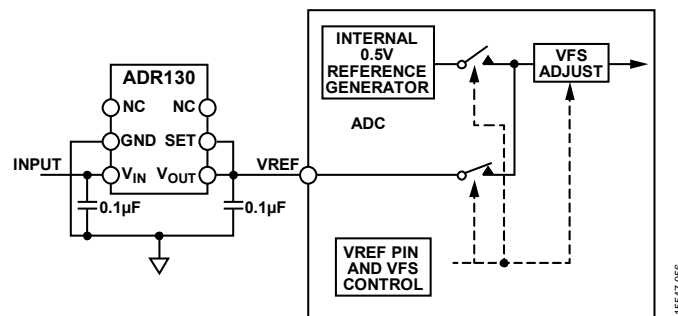

Figure 60. External Reference Using the ADR130

## VOLTAGE REFERENCE

A stable and accurate 0.5 V voltage reference is built into the AD9208. This internal 0.5 V reference sets the full-scale input range of the ADC. The full-scale input range can be adjusted via the ADC input full-scale control register (Register 0x1910). For more information on adjusting the input swing, see Table 46. Figure 59 shows the block diagram of the internal 0.5 V reference controls.

The SPI Register 0x18A6 enables the user to either use this internal 0.5 V reference, or to provide an external 0.5 V reference. When using an external voltage reference, provide a 0.5 V reference. The full-scale adjustment is made using the SPI, irrespective of the reference voltage. For more information on adjusting the full-scale level of the AD9208, refer to the Memory Map section.

The SPI writes required to use the external voltage reference, in order, are as follows:

1. Set Register 0x18E3 to 0x00 to turn off the  $V_{CM}$  export.
2. Set Register 0x18E6 to 0x00 to turn off the temperature diode export.
3. Set Register 0x18A6 to 0x01 to turn on the external voltage reference.

The use of an external reference may be necessary, in some applications, to enhance the gain accuracy of the ADC or to improve thermal drift characteristics. Figure 61 shows the typical drift characteristics of the internal 0.5 V reference.

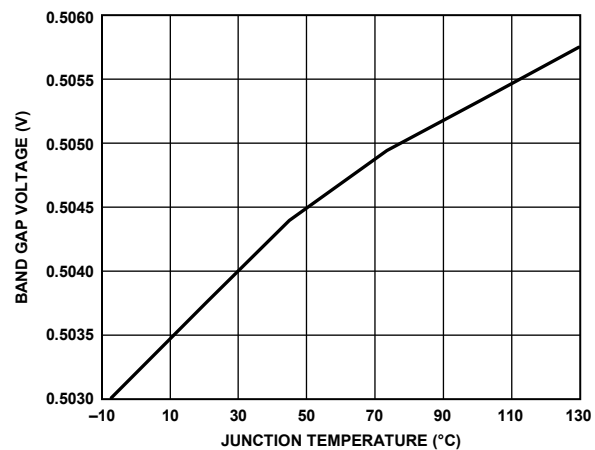
Figure 61. Typical  $V_{REF}$  Drift

The external reference must be a stable 0.5 V reference. The ADR130 is a sufficient option for providing the 0.5 V reference. Figure 60 shows how the ADR130 can be used to provide the external 0.5 V reference to the AD9208. The dashed lines show unused blocks within the AD9208 while using the ADR130 to provide the external reference.

**DC OFFSET CALIBRATION**

The AD9208 contains a digital filter to remove the dc offset from the output of the ADC. For ac-coupled applications, this filter can be enabled by writing 0x86 to Register 0x0701. The filter computes the average dc signal and it is digitally subtracted from the ADC output. As a result, the dc offset is improved to better than 70 dBFS at the output. Because the filter does not distinguish between the source of dc signals, this feature can be used when the signal content at dc is not of interest. The filter corrects dc up to  $\pm 512$  codes and saturates beyond that.

**CLOCK INPUT CONSIDERATIONS**

For optimum performance, drive the AD9208 sample clock inputs (CLK+ and CLK-) with a differential signal. This signal is ac-coupled to the CLK+ and CLK- pins via a transformer or clock drivers. These pins are biased internally and require no additional biasing.

Figure 62 shows the differential input return loss curve for the clock inputs across a frequency range of 100 MHz to 6 GHz. The reference impedance is 100  $\Omega$ .

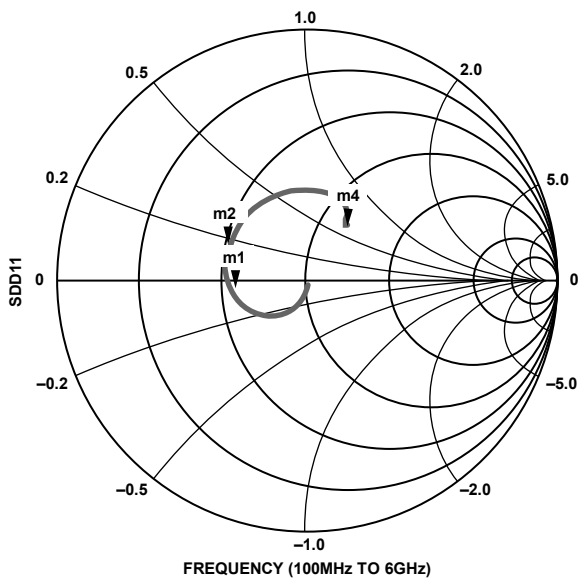

|   |  |
|---|--|
| <p>m1<br/>                 FREQUENCY = 2.503GHz<br/>                 SDD11 = 0.313/-173.307<br/>                 IMPEDANCE = <math>Z_0 \times (0.524 - j0.042)</math></p> | <p>m3<br/>                 FREQUENCY = 3.104GHz<br/>                 SDD11 = 0.332/165.502<br/>                 IMPEDANCE = <math>Z_0 \times (0.508 - j0.095)</math></p> |
| <p>m2<br/>                 FREQUENCY = 2.996GHz<br/>                 SDD11 = 0.337/169.383<br/>                 IMPEDANCE = <math>Z_0 \times (0.499 - j0.070)</math></p>  | <p>m4<br/>                 FREQUENCY = 6GHz<br/>                 SDD11 = 0.271/54.790<br/>                 IMPEDANCE = <math>Z_0 \times (1.218 - j0.581)</math></p>      |

Figure 62. Differential Input Return Loss for the CLK± Inputs

Figure 63 shows a preferred method for clocking the AD9208. The low jitter clock source is converted from a single-ended signal to a differential signal using an RF transformer.

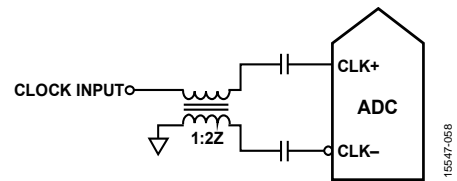

Figure 63. Transformer-Coupled Differential Clock

Another option is to ac couple a differential CML or LVPECL signal to the sample clock input pins, as shown in Figure 64 and Figure 65.

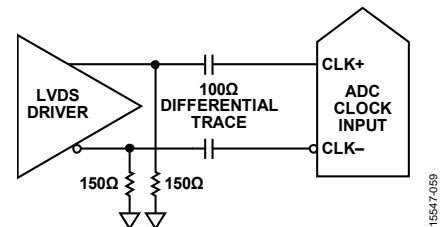

Figure 64. Differential LVPECL Sample Clock

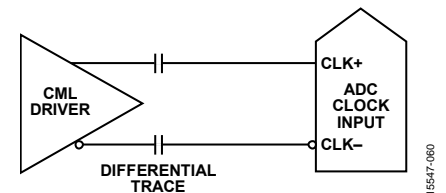

Figure 65. Differential CML Sample Clock

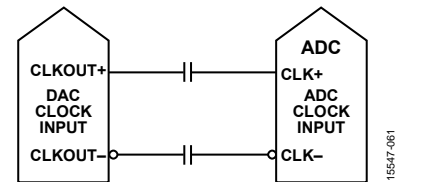

Figure 66. Clock Output Clocking the AD9208

### Clock Duty Cycle Considerations

Typical high speed ADCs use both clock edges to generate a variety of internal timing signals. The AD9208 contains an internal clock divider and a duty cycle stabilizer comprised of DCS1 and DCS2, which is enabled by default. In applications where the clock duty cycle cannot be guaranteed to be 50%, a higher multiple frequency clock along with the usage of the clock divider is recommended.

When it is not possible to provide a higher frequency clock, it is recommended to turn on the DCS using Register 0x011C and Register 0x011E. Figure 67 shows the different controls to the AD9208 clock inputs. The output of the divider offers a 50% duty cycle, high slew rate (fast edge) clock signal to the internal ADC. See the Memory Map section for more details on using this feature.

### Input Clock Divider

The AD9208 contains an input clock divider with the ability to divide the input clock by 1, 2, or 4. Select the divider ratios using Register 0x0108 (see Figure 67).

The maximum frequency at the CLK± inputs is 6 GHz, which is the limit of the divider. In applications where the clock input is a multiple of the sample clock, take care to program the appropriate divider ratio into the clock divider before applying the clock signal; this ensures that the current transients during device startup are controlled.

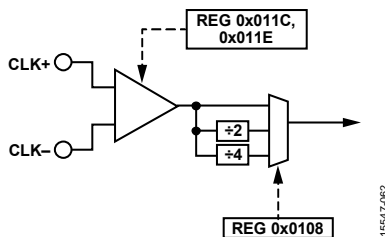

Figure 67. Clock Divider Circuit

The AD9208 clock divider can be synchronized using the external SYSREF± input. A valid SYSREF± signal causes the clock divider to reset to a programmable state. This synchronization feature allows multiple devices to have their clock dividers aligned to guarantee simultaneous input sampling. See the Memory Map Register Details section for more information.

### Input Clock Divider ½ Period Delay Adjust

The input clock divider in the AD9208 provides phase delay in increments of ½ the input clock cycle. Program Register 0x0109 to enable this delay independently for each channel. Changing this register does not affect the stability of the JESD204B link.

### Clock Fine Delay and Superfine Delay Adjust

Adjust the AD9208 sampling edge instant by writing to Register 0x0110, Register 0x0111, and Register 0x0112. Bits[2:0] of Register 0x0110 enable the selection of the fine delay, or the fine delay with superfine delay. The fine delay allows the user to delay the clock edges with 16 step or 192 step delay options. The superfine delay is an unsigned control to adjust the clock delay in superfine steps of 0.25 ps each.

Register 0x0112, Bits[7:0] offer the user the option to delay the clock in 192 delay steps. Register 0x0111, Bits[7:0] offer the user the option to delay the clock in 128 superfine steps. These values can be programmed individually for each channel. To use the superfine delay option, set the clock delay control in Register 0x0110, Bits[2:0] to 0x2 or 0x6. Figure 68 shows the controls available to the clock dividers within AD9208. It is recommended to apply the same delay settings to the digital delay circuits as are applied to the analog delay circuits to maintain sample accuracy through the pipe.

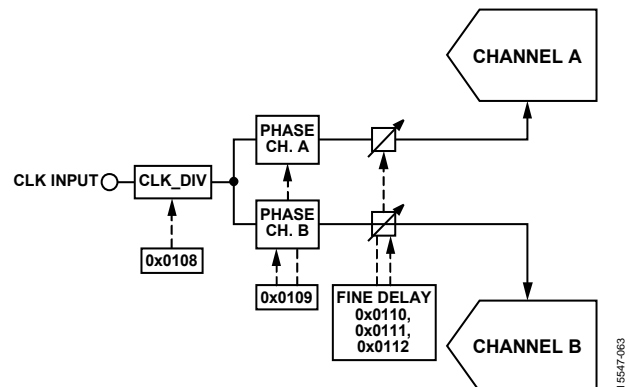

Figure 68. Clock Divider Phase and Delay Controls

The clock delay adjustment takes effect immediately when it is enabled via SPI writes. Enabling the clock fine delay adjust in Register 0x0110 causes a datapath reset. However, the contents of Register 0x0111 and Register 0x0112 can be changed without affecting the stability of the JESD204B link.

### Clock Coupling Considerations

The AD9208 has many different domains within the analog supply that control various aspects of the data conversion. The clock domain is supplied by Pin A4, Pin A5, Pin A10, Pin A11, Pin B4, and Pin B11 on the analog supply, AVDD1 (0.975 V) and Pin A6, Pin A9, Pin B6, Pin B7, Pin B8, Pin B9, Pin C6, Pin C7, Pin C8, Pin C9, Pin D7, and Pin D8 on the ground (AGND) side. To minimize coupling between the clock supply domain and the other analog domains, it is recommended to add a supply Q factor reduction circuitry (de-Q) for Pin A4 and Pin A11, as well as Pin B4 and Pin B11, as shown in Figure 69.

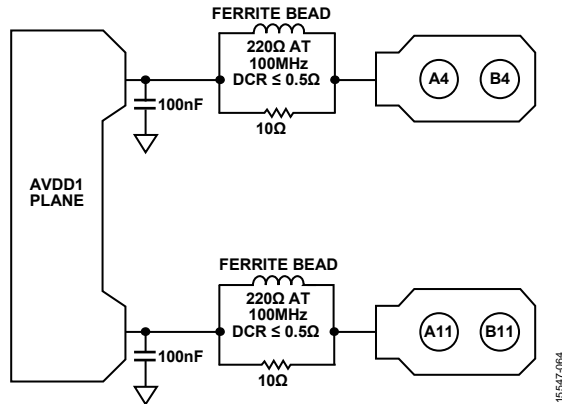

Figure 69. De-Q Network Recommendation for the Clock Domain Supply

**Clock Jitter Considerations**

High speed, high resolution ADCs are sensitive to the quality of the clock input. Calculate the degradation in SNR at a given input frequency ( $f_A$ ) due only to aperture jitter ( $t_j$ ) by

$$SNR_{JITTER} = -20 \times \log_{10} (2 \times \pi \times f_A \times t_j)$$

In this equation, the rms aperture jitter represents the root mean square of all jitter sources, including the clock input, analog input signal, and ADC aperture jitter specifications.

IF undersampling applications are particularly sensitive to jitter (see Figure 70).

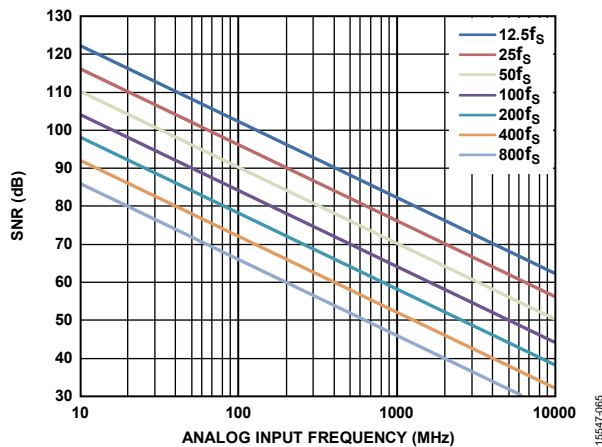

Figure 70. Ideal SNR vs. Input Frequency and Jitter

Treat the clock input as an analog signal when aperture jitter may affect the dynamic range of the AD9208. Separate power supplies for clock drivers from the ADC output driver supplies to avoid modulating the clock signal with digital noise. If the clock is generated from another type of source (by gating, dividing, or other methods), retime the clock by the original clock at the last step. Refer to the AN-501 Application Note and the AN-756 Application Note for more in depth information about jitter performance as it relates to ADCs.

Figure 71 shows the estimated SNR of the AD9208 across input frequency for different clock induced jitter values. Estimate the SNR by using the following equation:

$$SNR \text{ (dBFS)} = -10 \log_{10} \left( 10^{\left( \frac{-SNR_{ADC}}{10} \right)} + 10^{\left( \frac{-SNR_{JITTER}}{10} \right)} \right)$$

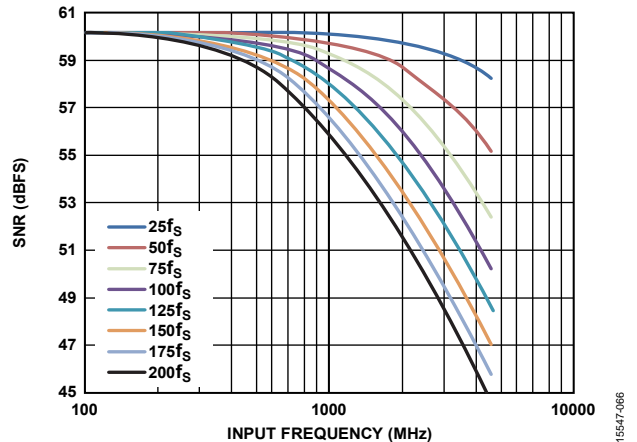

Figure 71. Estimated SNR Degradation for the AD9208 vs. Input Frequency and RMS Jitter

**POWER-DOWN/STANDBY MODE**

The AD9208 has a PDWN/STBY pin that can be used to configure the device in power-down or standby mode. The default operation is PDWN. The PDWN/STBY pin is a logic high pin. When in power-down mode, the JESD204B link is disrupted. The power-down option can also be set via Register 0x003F and Register 0x0040.

In standby mode, the JESD204B link is not disrupted and transmits zeros for all converter samples. Change this transmission using Register 0x0571, Bit 7 to select /K/ characters.

**TEMPERATURE DIODE**

The AD9208 contains diode-based temperature sensors. The diodes output voltages commensurate to the temperature of the silicon. There are multiple diodes on the die, but the results established using the temperature diode at the central location of the die can be regarded as representative of the entire die. However, in applications where only one channel is used (the other channel being in a power-down state), it is recommended to read the temperature diode corresponding to the channel that is on. The Figure 72 shows the locations of the diodes in the AD9208 with voltages that can be output to the VREF pin. In each location, there is a pair of diodes, one of which is 20x the size of the other. It is recommended to use both diodes in a location to obtain an accurate estimate of the die temperature. For more information, see the AN-1432 Application Note, Practical Thermal Modeling and Measurements in High Power ICs.

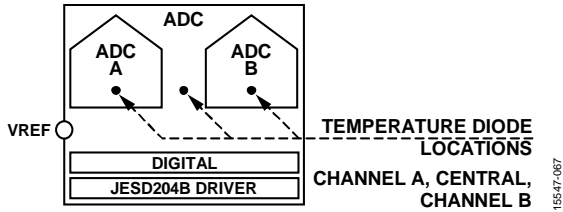

Figure 72. Temperature Diode Locations in the Die

The temperature diode voltages can be exported to the VREF pin using the SPI. Use Register 0x18E6 to enable or disable diodes. It is important to note that other voltages may be exported to the VREF pin at the same time, which can result in undefined behavior. To ensure a proper readout, switch off all other voltage exporting circuits as described in this section. Figure 73 shows the block diagram of the controls that are required to enable the diode voltage readout.

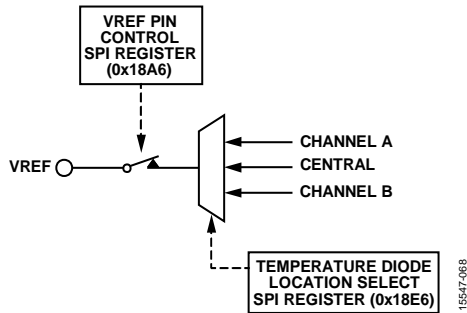

Figure 73. Register Controls to Output Temperature Diode Voltage on the VREF Pin

The SPI writes required to export the central temperature diode are as follows (see Table 46 for more information):

1. Set Register 0x0008 to 0x03 to select both channels.
2. Set Register 0x18E3 to 0x00 to turn off  $V_{CM}$  export.
3. Set Register 0x18A6 to 0x00 to turn off voltage reference export.
4. Set Register 0x18E6 to 0x01 to turn on voltage export of the central 1× temperature diode. The typical voltage response of the temperature diode is shown in Figure 74. Although this voltage represents the die temperature, it is recommended to take measurements from a pair of diodes for improved accuracy. The following step explains how to enable the 20× diode.
5. Set Register 0x18E6 to 0x02 to turn on the second central temperature diode of the pair, which is 20× the size of the first. For the method using two diodes simultaneously to achieve a more accurate result, see the [AN-1432 Application Note, Practical Thermal Modeling and Measurements in High Power ICs](#).

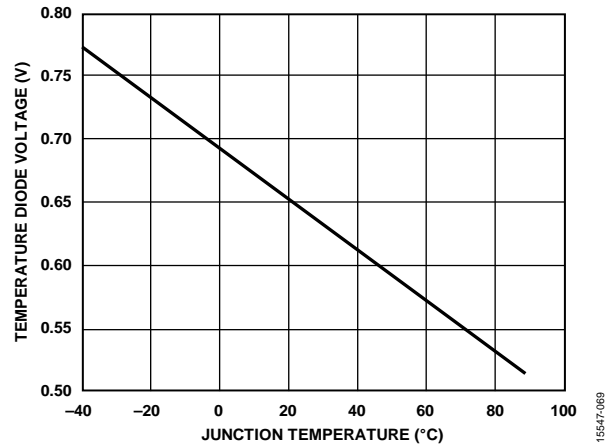

Figure 74. Typical Voltage Response of the 1× Temperature Diode

The relationship between the measured delta voltage ( $\Delta V$ ) and the junction temperature in °C is shown in Figure 75.

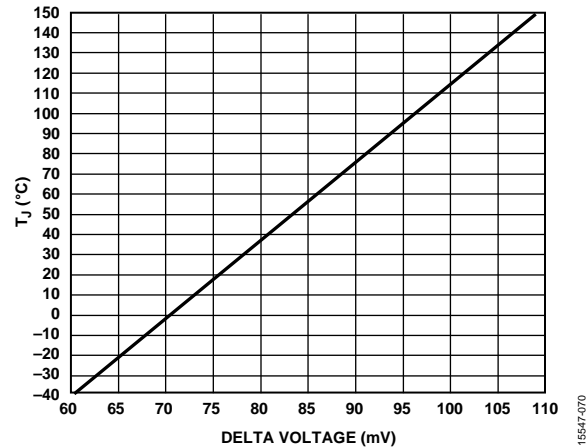

Figure 75. Junction Temperature vs.  $\Delta V$  (mV)



## ADC OVERRANGE AND FAST DETECT

In receiver applications, it is desirable to have a mechanism to reliably determine when the converter is about to be clipped. The standard overrange bit in the JESD204B outputs provides information on the state of the analog input that is of limited usefulness. Therefore, it is helpful to have a programmable threshold below full scale that allows time to reduce the gain before the clip actually occurs. In addition, because input signals can have significant slew rates, the latency of this function is of major concern. Highly pipelined converters can have significant latency. The AD9208 contains fast detect circuitry for individual channels to monitor the threshold and assert the FD\_A and FD\_B pins.

### ADC OVERRANGE

The ADC overrange indicator is asserted when an overrange is detected on the input of the ADC. The overrange indicator can be embedded within the JESD204B link as a control bit (when CSB > 0). The latency of this overrange indicator matches the sample latency.

The AD9208 also records any overrange condition in any of the eight virtual converters. For more information on the virtual converters, refer to Figure 84. The overrange status of each virtual converter is registered as a sticky bit in Register 0x0563. The contents of Register 0x0563 can be cleared using Register 0x0562, by toggling the bits corresponding to the virtual converter to set and reset position.

### FAST THRESHOLD DETECTION (FD\_A AND FD\_B)

The FD\_A or FD\_B pin is immediately set whenever the absolute value of the input signal exceeds the programmable upper threshold level. The FD bit is only cleared when the absolute value of the input signal drops below the lower threshold level for greater than the programmable dwell time. This feature provides hysteresis and prevents the FD bit from excessively toggling.

The operation of the upper threshold and lower threshold registers, along with the dwell time registers, is shown in Figure 76.

The FD indicator is asserted if the input magnitude exceeds the value programmed in the fast detect upper threshold registers, located at Register 0x0247 and Register 0x0248. The selected threshold register is compared with the signal magnitude at the output of the ADC. The fast upper threshold detection has a latency of 28 clock cycles (maximum). The approximate upper threshold magnitude is defined by

$$\text{Upper Threshold Magnitude (dBFS)} = 20\log(\text{Threshold Magnitude}/2^{13})$$

The FD indicators are not cleared until the signal drops below the lower threshold for the programmed dwell time. The lower threshold is programmed in the fast detect lower threshold registers, located at Register 0x0249 and Register 0x024A. The fast detect lower threshold register is a 13-bit register that is compared with the signal magnitude at the output of the ADC. This comparison is subject to the ADC pipeline latency, but is accurate in terms of converter resolution. The lower threshold magnitude is defined by

$$\text{Lower Threshold Magnitude (dBFS)} = 20\log(\text{Threshold Magnitude}/2^{13})$$

For example, to set an upper threshold of -6 dBFS, write 0xFF to Register 0x0247 and Register 0x0248. To set a lower threshold of -10 dBFS, write 0xA1D to Register 0x0249 and Register 0x024A.

The dwell time can be programmed from 1 to 65,535 sample clock cycles by placing the desired value in the fast detect dwell time registers, located at Register 0x024B and Register 0x024C. See Register 0x0040 and Register 0x0245 to Register 0x024C in the Memory Map section (see Table 46) for more details.

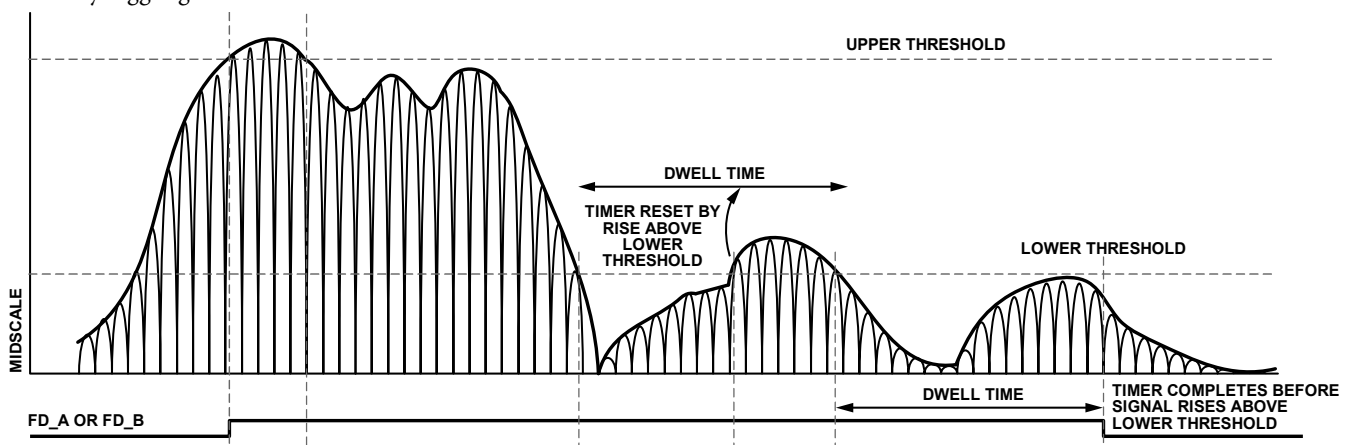

Figure 76. Threshold Settings for the FD\_A and FD\_B Signals

15547-071

## ADC APPLICATION MODES AND JESD204B Tx CONVERTER MAPPING

The AD9208 contains a configurable signal path that allows different features to be enabled for different applications. These features are controlled using the chip application mode register, Register 0x0200. The chip operating mode is controlled by Bits[3:0] in this register, and the chip Q ignore is controlled by Bit 5.

The AD9208 contains the following modes:

- Full bandwidth mode: two 14-bit ADC cores running at full sample rate.
- DDC mode: up to four digital downconverter (DDC) channels.

After the chip application mode is selected, the output decimation ratio is set using the chip decimation ratio in Register 0x0201, Bits[3:0]. The output sample rate = ADC sample rate/the chip decimation ratio.

To support the different application layer modes, the AD9208 treats each sample stream (real, I, or Q) as originating from separate virtual converters.

Table 11 shows the number of virtual converters required and the transport layer mapping when channel swapping is disabled. Figure 77 shows the virtual converters and their relationship to the DDC outputs when complex outputs are used.

Each DDC channel outputs either two sample streams (I/Q) for the complex data components (real + imaginary), or one sample stream for real (I) data. The AD9208 can be configured to use up to eight virtual converters, depending on the DDC configuration.

The I/Q samples are always mapped in pairs with the I samples mapped to the first virtual converter and the Q samples mapped to the second virtual converter. With this transport layer mapping, the number of virtual converters are the same whether a single real converter is used along with a digital downconverter block producing I/Q outputs, or whether an analog downconversion is used with two real converters producing I/Q outputs.

Figure 78 shows a block diagram of the two scenarios described for I/Q transport layer mapping.

Table 11. Virtual Converter Mapping

| Number of Virtual Converters Supported | Chip Operating Mode (Reg. 0x0200, Bits[3:0]) | Chip Q Ignore (0x0200, Bit 5) | Virtual Converter Mapping |                |                |                |                |                |                |                |
|--|--|-------------------------------|---------------------------|----------------|----------------|----------------|----------------|----------------|----------------|----------------|
|  |  |                               | 0                         | 1              | 2              | 3              | 4              | 5              | 6              | 7              |
| 1 to 2                                 | Full bandwidth mode (0x0)                    | Real or complex (0x0)         | ADC A samples             | ADC B samples  | Unused         | Unused         | Unused         | Unused         | Unused         | Unused         |
| 1                                      | One DDC mode (0x1)                           | Real (I only) (0x1)           | DDC0 I samples            | Unused         | Unused         | Unused         | Unused         | Unused         | Unused         | Unused         |
| 2                                      | One DDC mode (0x1)                           | Complex (I/Q) (0x0)           | DDC0 I samples            | DDC0 Q samples | Unused         | Unused         | Unused         | Unused         | Unused         | Unused         |
| 2                                      | Two DDC mode (0x2)                           | Real (I only) (0x1)           | DDC0 I samples            | DDC1 I samples | Unused         | Unused         | Unused         | Unused         | Unused         | Unused         |
| 4                                      | Two DDC mode (0x2)                           | Complex (I/Q) (0x0)           | DDC0 I samples            | DDC0 Q samples | DDC1 I samples | DDC1 Q samples | Unused         | Unused         | Unused         | Unused         |
| 4                                      | Four DDC mode (0x3)                          | Real (I only) (0x1)           | DDC0 I samples            | DDC1 I samples | DDC2 I samples | DDC3 I samples | Unused         | Unused         | Unused         | Unused         |
| 8                                      | Four DDC mode (0x3)                          | Complex (I/Q) (0x0)           | DDC0 I samples            | DDC0 Q samples | DDC1 I samples | DDC1 Q samples | DDC2 I samples | DDC2 Q samples | DDC3 I samples | DDC3 Q samples |

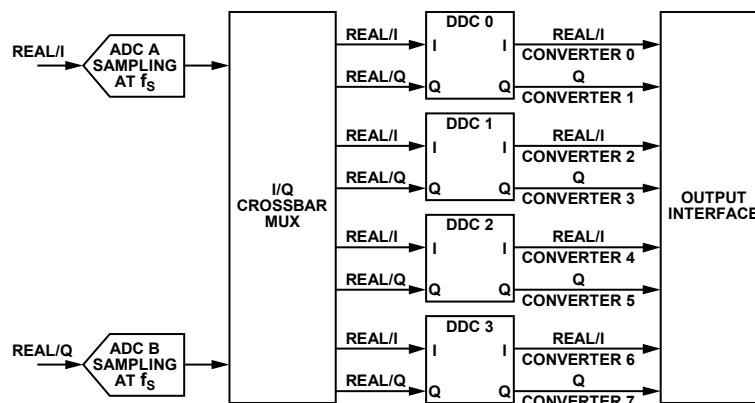

Figure 77. DDCs and Virtual Converter Mapping

15547-072

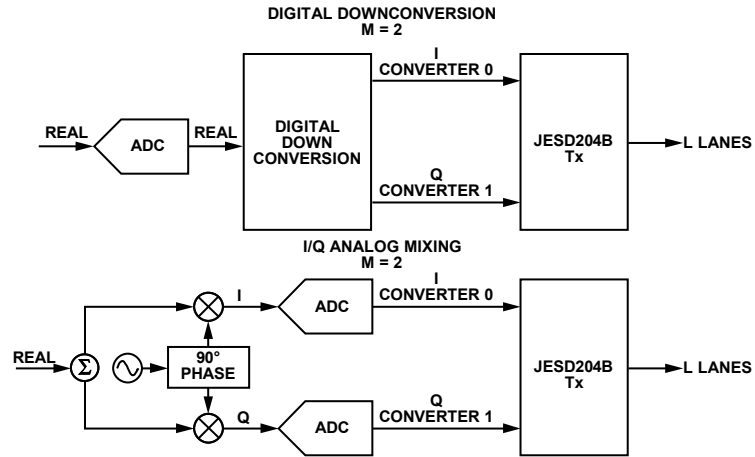

Figure 78. I/Q Transport Layer Mapping

# PROGRAMMABLE FIR FILTERS

## SUPPORTED MODES

The AD9208 supports the following modes of operation (the asterisk symbol (\*) denotes convolution):

- Real 48-tap filter for each I/Q channel (see Figure 79)
  - $DOUT\_I[n] = DIN\_I[n] * XY\_I[n]$
  - $DOUT\_Q[n] = DIN\_Q[n] * XY\_Q[n]$
- Real 96-tap filter for on either I or Q channel (see Figure 80)
  - $DOUT\_I[n] = DIN\_I[n] * XY\_I[n]$
  - $DOUT\_Q[n] = DIN\_Q[n] * XY\_Q[n]$
- Real set of two cascaded 24-tap filters for each I/Q channel (see Figure 81)
  - $DOUT\_I[n] = DIN\_I[n] * X\_I[n] * Y\_I[n]$
  - $DOUT\_Q[n] = DIN\_Q[n] * X\_Q[n] * Y\_Q[n]$
- Half complex filter using two real 48-tap filters for the I/Q channels (see Figure 82)
  - $DOUT\_I[n] = DIN\_I[n]$
  - $DOUT\_Q[n] = DIN\_Q[n] * XY\_Q[n] + DIN\_I[n] * XY\_I[n]$
- Full complex filter using four real 24-tap filters for the I/Q channels (see Figure 83)
  - $DOUT\_I[n] = DIN\_I[n] * X\_I[n] + DIN\_Q[n] * Y\_Q[n]$
  - $DOUT\_Q[n] = DIN\_Q[n] * X\_Q[n] + DIN\_I[n] * Y\_I[n]$

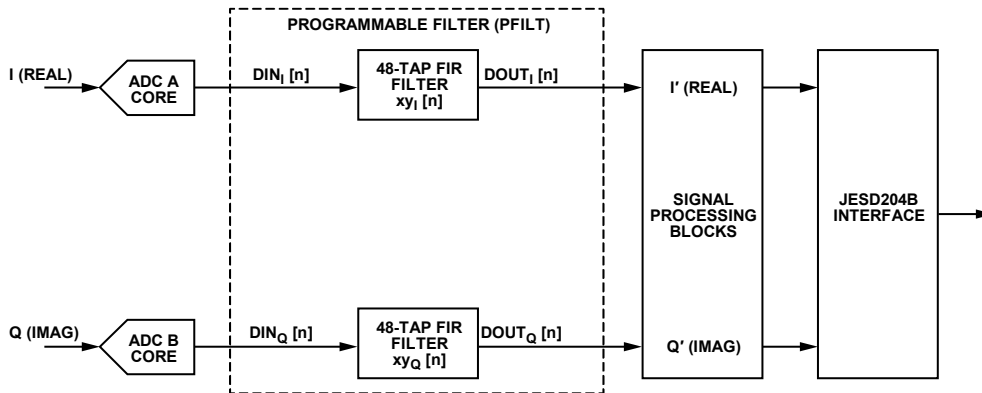

Figure 79. Real 48-Tap Filter Configuration

15647-074

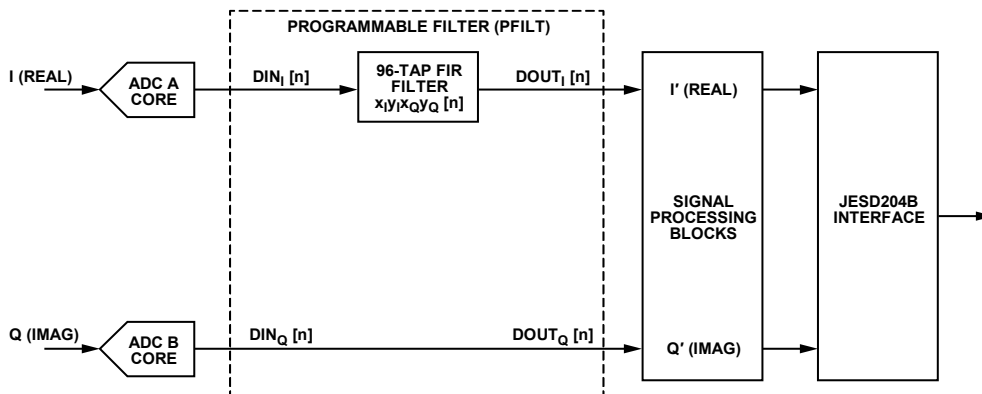

Figure 80. Real 96-Tap Filter Configuration

15647-075

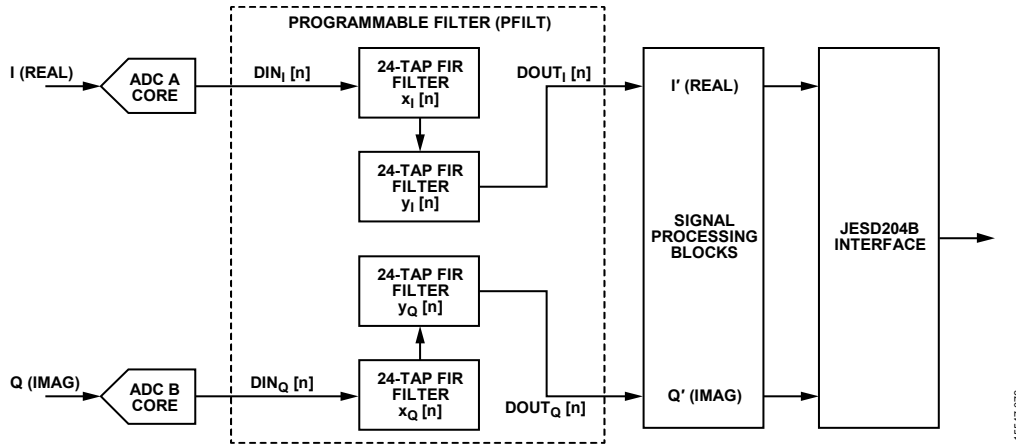

Figure 81. Real, Two Cascaded, 24-Tap Filter Configuration

15547-076

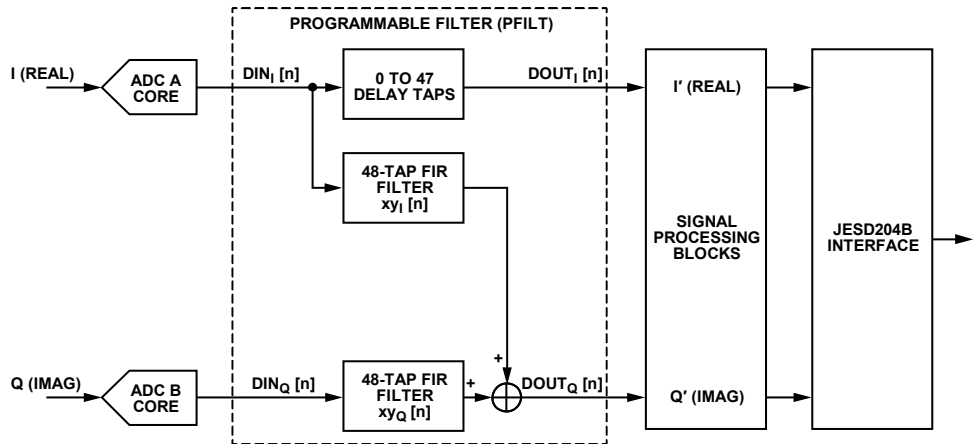

Figure 82. 48-Tap Half Complex Filter Configuration

15547-077

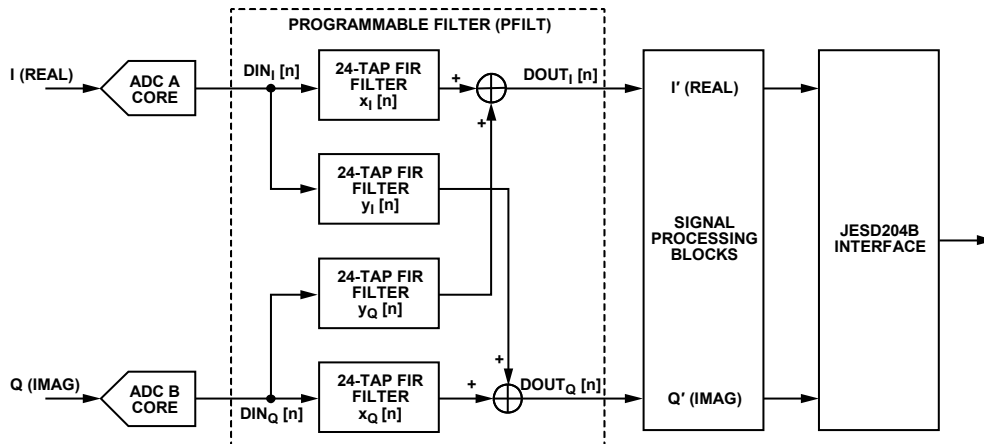

Figure 83. 24-Tap Full Complex Filter Configuration.

15547-078

## PROGRAMMING INSTRUCTIONS

Use the following procedure to set up the programmable FIR filter:

1. Enable the sample clock to the device.
2. Configure the mode registers as follows:
  - a. Set the device index to Channel A (I path) (Register 0x0008 = 0x01).
  - b. Set the I path mode (I mode) and gain in Register 0x0DF8 and Register 0x0DF9 (see Table 12 and Table 13).
  - c. Set the device index to Channel B (Q path) (Register 0x0008 = 0x02).
  - d. Set the Q path mode (Q mode) and gain in Register 0x0DF8 and Register 0x0DF9.
3. Wait at least 5  $\mu$ s to allow the programmable filter to power up.
4. Program the I path coefficients to the internal shadow registers as follows:
  - a. Set the device index to Channel A (I path) (Register 0x0008 = 0x01).
  - b. Program the XI coefficients in Register 0x0E00 to Register 0x0E2F (see Table 14 and Table 15).
  - c. Program the YI coefficients in Register 0x0F00 to Register 0x0F2F (see Table 14 and Table 15).
  - d. Program the tapped delay in Register 0x0F30 (note that this step is optional).
5. Program the Q path coefficients to the internal shadow registers as follows:
  - a. Set the device index to Channel B (Q path) (Register 0x0008 = 0x02).
  - b. Set the Q path mode and gain in Register 0x0DF8 and Register 0x0DF9 (see Table 12 and Table 13).
  - c. Program the XQ coefficients in Register 0x0E00 to Register 0x0E2F (see Table 14 and Table 15).
  - d. Program the YQ coefficients in Register 0x0F00 to Register 0x0F2F (see Table 14 and Table 15).
  - e. Program the tapped delay in Register 0x0F30 (note that this step is optional).
6. Set the chip transfer bit using either of the following methods (note that setting the chip transfer bit applies the programmed shadow coefficients to the filter):
  - a. Via the register map using the write the chip transfer bit (Register 0x000F = 0x01).
  - b. Via a GPIO pin, as follows:
    - i. Configure one of the GPIO pins as the chip transfer bit in Register 0x0040 to Register 0x0042.
    - ii. Toggle the GPIO pin to initiate the chip transfer (the rising edge is triggered).
7. When the I or Q path mode register changes in Register 0x0DF8, all coefficients must be reprogrammed.

**Table 12. Register 0x0DF8 Definition**

| Bit(s) | Description   |
|--------|---|
| [7:3]  | Reserved  |
| [2:0]  | Filter mode (I mode or Q mode)<br>000: filters bypassed<br>001: real 24-tap filter (X only)<br>010: real 48-tap filter (X and Y together)<br>100: real set of two cascaded 24-tap filters (X then Y cascaded)<br>101: full complex filter using four real 24-tap filters for the A/B channels (opposite channel must also be set to 101)<br>110: half complex filter using two real 48-tap filters + 48-tap delay line (X and Y together) (opposite channel must also be set to 010)<br>111: real 96-tap filter (XI, YI, XQ, and YQ together) (opposite channel must be set to 000) |

**Table 13. Register 0x0DF9 Definition**

| Bit(s) | Description   |
|--------|---|
| 7      | Reserved  |
| [6:4]  | Y filter gain<br>110: -12 dB loss<br>111: -6 dB loss<br>000: 0 dB gain<br>001: 6 dB gain<br>010: 12 dB gain |
| 3      | Reserved  |
| [2:0]  | X filter gain<br>110: -12 dB loss<br>111: -6 dB loss<br>000: 0 dB gain<br>001: 6 dB gain<br>010: 12 dB gain |

Table 14 and Table 15 show the coefficient tables in Register 0x0E00 to Register 0x0F30. Note that all coefficients are Q1.15 format (sign bit + 15 fractional bits).

Table 14. I Coefficient Table (Device Selection = 0x1)<sup>1</sup>

| Addr.  | Single 24-Tap Filter (I Mode [2:0] = 0x1) | Single 48-Tap Filter (I Mode [2:0] = 0x2) | Two Cascaded 24-Tap Filters (I Mode [2:0] = 0x4) | Full Complex 24-Tap Filters (I Mode [2:0] = 0x5 and Q Mode [2:0] = 0x5) | Half Complex 48-Tap Filters (I Mode [2:0] = 0x6 and Q Mode [2:0] = 0x2) <sup>2</sup>                                     | I Path 96-Tap Filter (I Mode [2:0] = 0x7 and Q Mode [2:0] = 0x0) <sup>3</sup> | Q Path 96-Tap Filter (I Mode [2:0] = 0x0 and Q Mode [2:0] = 0x7) <sup>3</sup> |
|--------|---|---|--|---|--|---|---|
| 0x0E00 | XI C0 [7:0]                               | XI C0 [7:0]                               | XI C0 [7:0]                                      | XI C0 [7:0]   | XI C0 [7:0]  | XI C0 [7:0]   | XQ C48 [7:0]  |
| 0x0E01 | XI C0 [15:8]                              | XI C0 [15:8]                              | XI C0 [15:8]                                     | XI C0 [15:8]  | XI C0 [15:8]   | XI C0 [15:8]  | XQ C48 [15:8]   |
| 0x0E02 | XI C1 [7:0]                               | XI C1 [7:0]                               | XI C1 [7:0]                                      | XI C1 [7:0]   | XI C1 [7:0]  | XI C1 [7:0]   | XQ C49 [7:0]  |
| 0x0E03 | XI C1 [15:8]                              | XI C1 [15:8]                              | XI C1 [15:8]                                     | XI C1 [15:8]  | XI C1 [15:8]   | XI C1 [15:8]  | XQ C49 [15:8]   |
| ...    | ...                                       | ...                                       | ...  | ...   | ...  | ...   | ...   |
| 0x0E2E | XI C23 [7:0]                              | XI C23 [7:0]                              | XI C23 [7:0]                                     | XI C23 [7:0]  | XI C23 [7:0]   | XI C23 [7:0]  | XQ C71 [7:0]  |
| 0x0E2F | XI C23 [15:0]                             | XI C23 [15:0]                             | XI C23 [15:0]                                    | XI C23 [15:0]   | XI C23 [15:0]  | XI C23 [15:0]   | XQ C71 [15:0]   |
| 0x0F00 | Unused                                    | YI C24 [7:0]                              | YI C0 [7:0]                                      | YI C0 [7:0]   | YI C24 [7:0]   | YI C24 [7:0]  | YQ C72 [7:0]  |
| 0x0F01 | Unused                                    | YI C24 [15:8]                             | YI C0 [15:8]                                     | YI C0 [15:8]  | YI C24 [15:8]  | YI C24 [15:8]   | YQ C72 [15:8]   |
| 0x0F02 | Unused                                    | YI C25 [7:0]                              | YI C1 [7:0]                                      | YI C1 [7:0]   | YI C25 [7:0]   | YI C25 [7:0]  | YQ C73 [7:0]  |
| 0x0F03 | Unused                                    | YI C25 [15:8]                             | YI C1 [15:8]                                     | YI C1 [15:8]  | YI C25 [15:8]  | YI C25 [15:8]   | YQ C73 [15:8]   |
| ...    | ...                                       | ...                                       | ...  | ...   | ...  | ...   | ...   |
| 0x0F2E | Unused                                    | YI C47 [7:0]                              | YI C23 [7:0]                                     | YI C23 [7:0]  | YI C47 [7:0]   | YI C47 [7:0]  | YQ C95 [7:0]  |
| 0x0F2F | Unused                                    | YI C47 [15:0]                             | YI C23 [15:0]                                    | YI C23 [15:0]   | YI C47 [15:0]  | YI C47 [15:0]   | YQ C95 [15:0]   |
| 0x0F30 | Unused                                    | Unused                                    | Unused   | Unused  | I path tapped delay<br>0: 0 tapped delay (matches C0 in the filter)<br>1: 1 tapped delays<br>...<br>47: 47 tapped delays | Unused  | Unused  |

<sup>1</sup> XI Cn means I Path X Coefficient n. YI Cn means I Path Y Coefficient n.

<sup>2</sup> When using the I path in half-complex 48-tap filter mode, the Q path must be in single 48-tap filter mode.

<sup>3</sup> When using the I path in 96-tap filter mode, the Q path must be in bypass mode.

Table 15. Q Coefficient Table (Device Selection = 0x2)<sup>1</sup>

| Addr.  | Single 24-Tap Filter (Q Mode [2:0] = 0x1) | Single 48-Tap Filter (Q Mode [2:0] = 0x2) | Two Cascaded 24-Tap Filters (Q Mode [2:0] = 0x4) | Full Complex 24-Tap Filters (Q Mode [2:0] = 0x5 and I Mode [2:0] = 0x5) | Half Complex 48-Tap Filters (Q Mode [2:0] = 0x6 and I Mode [2:0] = 0x2) <sup>2</sup>                                     | I Path 96-Tap Filter (Q Mode [2:0] = 0x0 and I Mode [2:0] = 0x7) <sup>3</sup> | Q Path 96-Tap Filter (Q Mode [2:0] = 0x7 and I Mode [2:0] = 0x0) <sup>3</sup> |
|--------|---|---|--|---|--|---|---|
| 0x0E00 | XQ C0 [7:0]                               | XQ C0 [7:0]                               | XQ C0 [7:0]                                      | XQ C0 [7:0]   | XQ C0 [7:0]  | XI C48 [7:0]  | XQ C0 [7:0]   |
| 0x0E01 | XQ C0 [15:8]                              | XQ C0 [15:8]                              | XQ C0 [15:8]                                     | XQ C0 [15:8]  | XQ C0 [15:8]   | XI C48 [15:8]   | XQ C0 [15:8]  |
| 0x0E02 | XQ C1 [7:0]                               | XQ C1 [7:0]                               | XQ C1 [7:0]                                      | XQ C1 [7:0]   | XQ C1 [7:0]  | XI C49 [7:0]  | XQ C1 [7:0]   |
| 0x0E03 | XQ C1 [15:8]                              | XQ C1 [15:8]                              | XQ C1 [15:8]                                     | XQ C1 [15:8]  | XQ C1 [15:8]   | XI C49 [15:8]   | XQ C1 [15:8]  |
| ...    | ...                                       | ...                                       | ...  | ...   | ...  | ...   | ...   |
| 0x0E2E | XQ C23 [7:0]                              | XQ C23 [7:0]                              | XQ C23 [7:0]                                     | XQ C23 [7:0]  | XQ C23 [7:0]   | XI C71 [7:0]  | XQ C23 [7:0]  |
| 0x0E2F | XQ C23 [15:0]                             | XQ C23 [15:0]                             | XQ C23 [15:0]                                    | XQ C23 [15:0]   | XQ C23 [15:0]  | XI C71 [15:0]   | XQ C23 [15:0]   |
| 0x0F00 | Unused                                    | YQ C24 [7:0]                              | YQ C0 [7:0]                                      | YQ C0 [7:0]   | YQ C24 [7:0]   | YI C72 [7:0]  | YQ C24 [7:0]  |
| 0x0F01 | Unused                                    | YQ C24 [15:8]                             | YQ C0 [15:8]                                     | YQ C0 [15:8]  | YQ C24 [15:8]  | YI C72 [15:8]   | YQ C24 [15:8]   |
| 0x0F02 | Unused                                    | YQ C25 [7:0]                              | YQ C1 [7:0]                                      | YQ C1 [7:0]   | YQ C25 [7:0]   | YI C73 [7:0]  | YQ C25 [7:0]  |
| 0x0F03 | Unused                                    | YQ C25 [15:8]                             | YQ C1 [15:8]                                     | YQ C1 [15:8]  | YQ C25 [15:8]  | YI C73 [15:8]   | YQ C25 [15:8]   |
| ...    | ...                                       | ...                                       | ...  | ...   | ...  | ...   | ...   |
| 0x0F2E | Unused                                    | YQ C47 [7:0]                              | YQ C23 [7:0]                                     | YQ C23 [7:0]  | YQ C47 [7:0]   | YI C95 [7:0]  | YQ C47 [7:0]  |
| 0x0F2F | Unused                                    | YQ C47 [15:0]                             | YQ C23 [15:0]                                    | YQ C23 [15:0]   | YQ C47 [15:0]  | YI C95 [15:0]   | YQ C47 [15:0]   |
| 0x0F30 | Unused                                    | Unused                                    | Unused   | Unused  | Q Path Tapped Delay<br>0: 0 tapped delay (matches C0 in the filter)<br>1: 1 tapped delays<br>...<br>47: 47 tapped delays | Unused  | Unused  |

<sup>1</sup> XQ Cn means Q Path X Coefficient n. YQ Cn means Q Path Y Coefficient n.

<sup>2</sup> When using the I path in half-complex 48-tap filter mode, the Q path must be in single 48-tap filter mode.

<sup>3</sup> When using the I path in 96-tap filter mode, the Q path must be in bypass mode.

## DIGITAL DOWNCONVERTER (DDC)

The [AD9208](#) includes four digital downconverters (DDC0 to DDC3) that provide filtering and reduce the output data rate. This digital processing section includes an NCO, multiple decimating FIR filters, a gain stage, and a complex to real conversion stage. Each of these processing blocks has control lines that allow it to be independently enabled and disabled to provide the desired processing function. The digital downconverter can be configured to output either real data or complex output data.

The DDCs output a 16-bit stream. To enable this operation, the converter number of bits,  $N$ , is set to a default value of 16, even though the analog core only outputs 14 bits. In full bandwidth operation, the ADC outputs are the 14-bit word followed by two zeros, unless the tail bits are enabled.

### DDC I/Q INPUT SELECTION

The [AD9208](#) has two ADC channels and four DDC channels. Each DDC channel has two input ports that can be paired to support both real and complex inputs through the I/Q crossbar mux. For real signals, both DDC input ports must select the same ADC channel (that is, DDC Input Port I = ADC Channel A and DDC Input Port Q = ADC Channel A). For complex signals, each DDC input port must select different ADC channels (that is, DDC Input Port I = ADC Channel A and DDC Input Port Q = ADC Channel B).

The inputs to each DDC are controlled by the DDC input selection registers (Register 0x0311, Register 0x0331, Register 0x0351, and Register 0x0371). See Table 46 for information on how to configure the DDCs.

### DDC I/Q OUTPUT SELECTION

Each DDC channel has two output ports that can be paired to support both real and complex outputs. For real output signals, only the DDC Output Port I is used (the DDC Output Port Q is invalid). For complex I/Q output signals, both DDC Output Port I and DDC Output Port Q are used.

The I/Q outputs to each DDC channel are controlled by the DDC complex to real enable bit, Bit 3, in the DDC control registers (Register 0x0310, Register 0x0330, Register 0x0350, and Register 0x0370).

The chip Q ignore bit in the chip mode register (Register 0x0200, Bit 5) controls the chip output muxing of all the DDC channels. When all DDC channels use real outputs, set this bit high to ignore all DDC Q output ports. When any of the DDC channels are set to use complex I/Q outputs, the user must clear this bit to use both DDC Output Port I and DDC Output Port Q. For more information, see Figure 101.

## DDC GENERAL DESCRIPTION

The four DDC blocks are used to extract a portion of the full digital spectrum captured by the ADC(s). They are intended for IF sampling or oversampled baseband radios requiring wide bandwidth input signals.

Each DDC block contains the following signal processing stages:

- Frequency translation stage (optional)
- Filtering stage
- Gain stage (optional)
- Complex to real conversion stage (optional)

### DDC Frequency Translation Stage (Optional)

This stage consists of a phase coherent NCO and quadrature mixers that can be used for frequency translation of both real or complex input signals. The phase coherent NCO allows an infinite number of frequency hops that are all referenced back to a single synchronization event. It also includes 16 shadow registers for fast switching applications. This stage shifts a portion of the available digital spectrum down to baseband.

### DDC Filtering Stage

After shifting down to baseband, this stage decimates the frequency spectrum using multiple low-pass finite impulse response (FIR) filters for rate conversion. The decimation process lowers the output data rate, which in turn reduces the output interface rate.

### DDC Gain Stage (Optional)

Because of losses associated with mixing a real input signal down to baseband, this stage compensates by adding an additional 0 dB or 6 dB of gain.

### DDC Complex to Real Conversion Stage (Optional)

When real outputs are necessary, this stage converts the complex outputs back to real by performing an  $f_s/4$  mixing operation plus a filter to remove the complex component of the signal.

Figure 84 shows the detailed block diagram of the DDCs implemented in the [AD9208](#).

Figure 85 shows an example usage of one of the four DDC channels with a real input signal and four half-band filters (HB4 + HB3 + HB2 + HB1) used. It shows both complex (decimate by 16) and real (decimate by 8) output options.



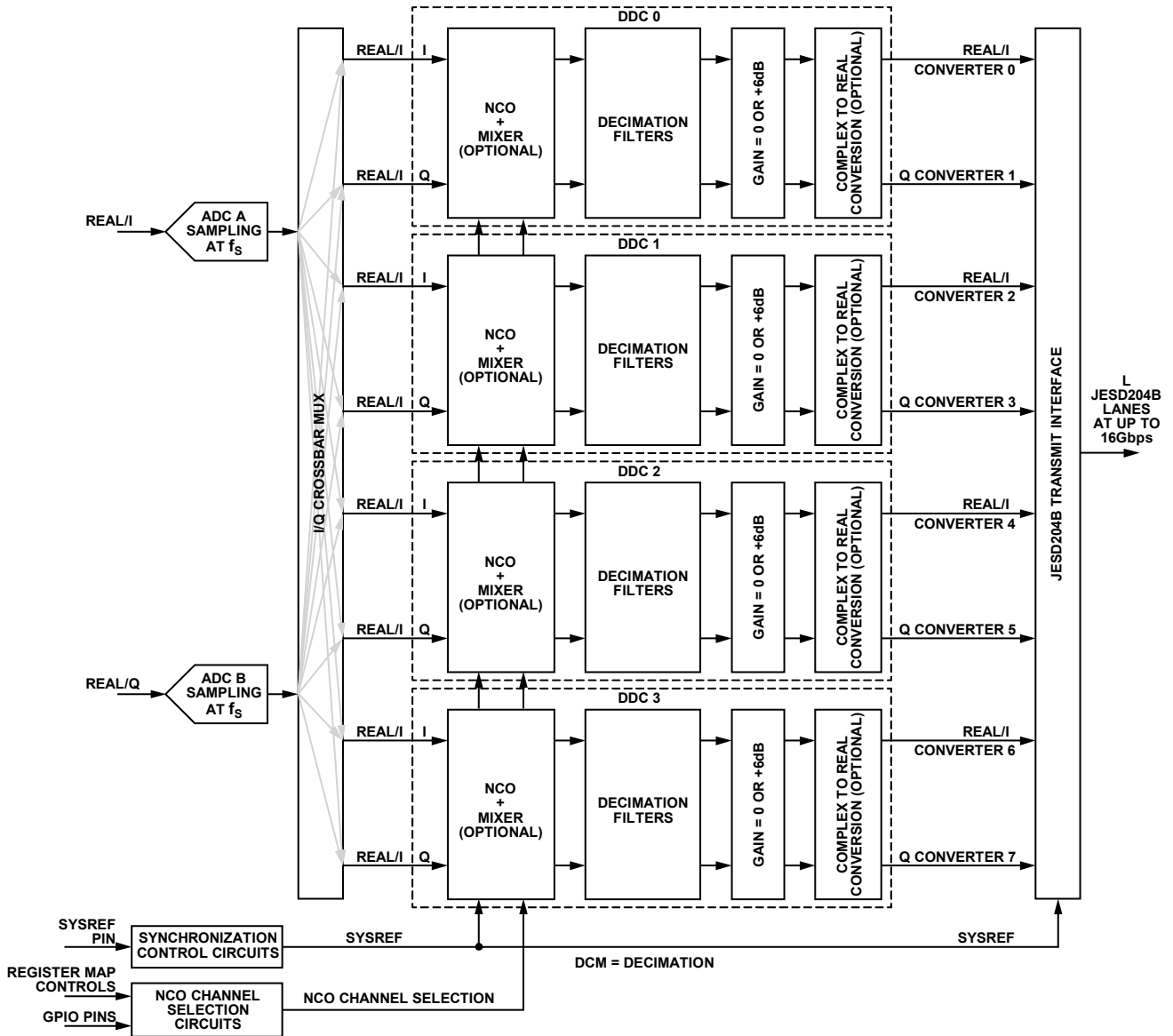

Figure 84. DDC Detailed Block Diagram

15547-079

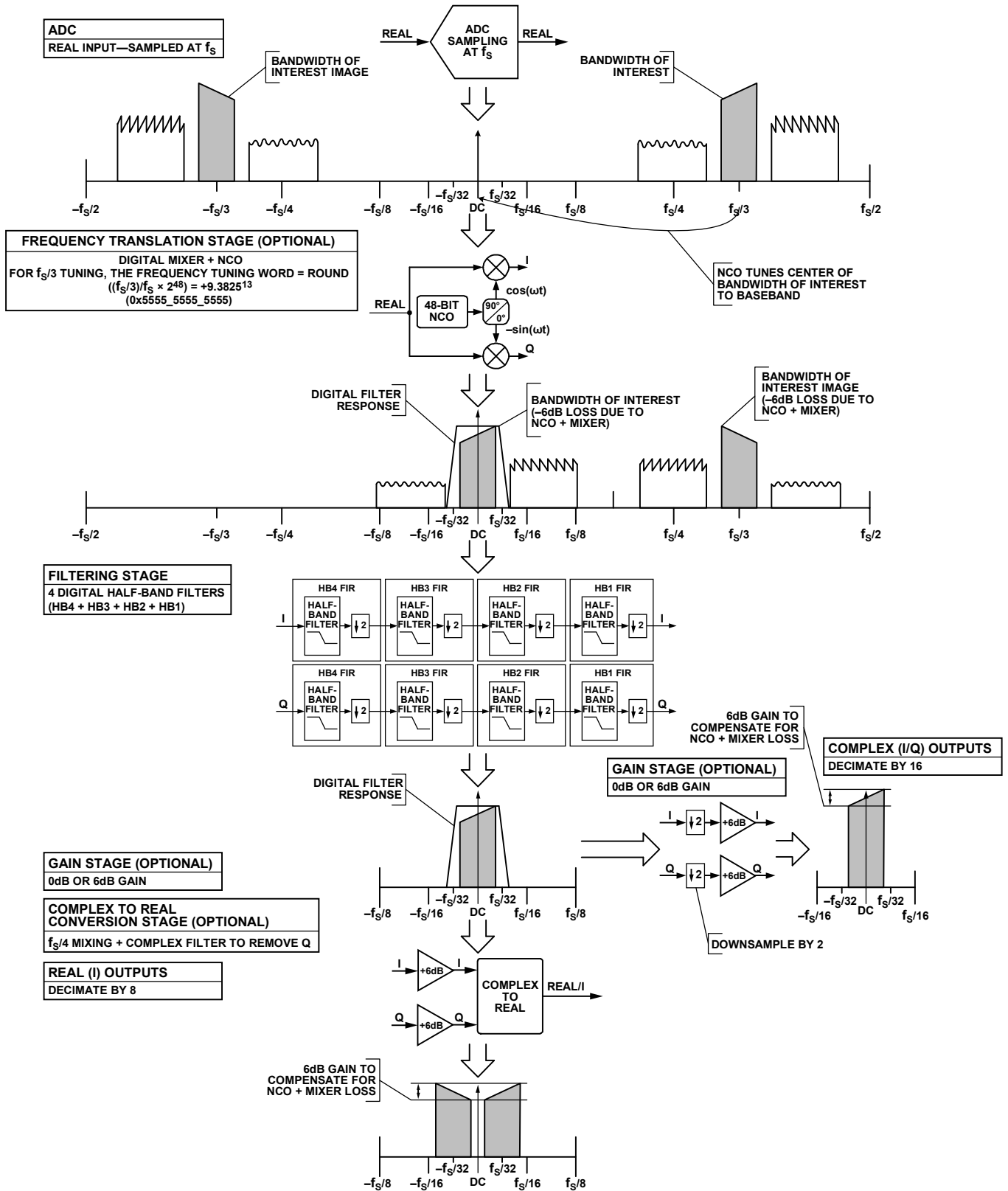

Figure 85. DDC Theory of Operation Example (Real Input)

**DDC FREQUENCY TRANSLATION**

**DDC Frequency Translation General Description**

Frequency translation is accomplished by using a 48-bit complex NCO with a digital quadrature mixer. This stage translates either a real or complex input signal from an IF to a baseband complex digital output (carrier frequency = 0 Hz).

The frequency translation stage of each DDC can be controlled individually and supports four different IF modes using Bits[5:4] of the DDC control registers (Register 0x0310, Register 0x0330, Register 0x0350, and Register 0x0370). These IF modes are

- Variable IF mode
- 0 Hz IF or zero IF (ZIF) mode
- $f_s/4$  Hz IF mode
- Test mode

**Variable IF Mode**

In this mode, the NCO and mixers are enabled. NCO output frequency can be used to digitally tune the IF frequency.

**0 Hz IF (ZIF) Mode**

In this mode, the mixers are bypassed, and the NCO is disabled.

**$f_s/4$  Hz IF Mode**

In this mode, the mixers and the NCO are enabled in downmixing by  $f_s/4$  mode to save power.

**Test Mode**

In this mode, input samples are forced to 0.999 to positive full scale. The NCO is enabled. This test mode allows the NCOs to directly drive the decimation filters.

Figure 86 and Figure 87 show examples of the frequency translation stage for both real and complex inputs.

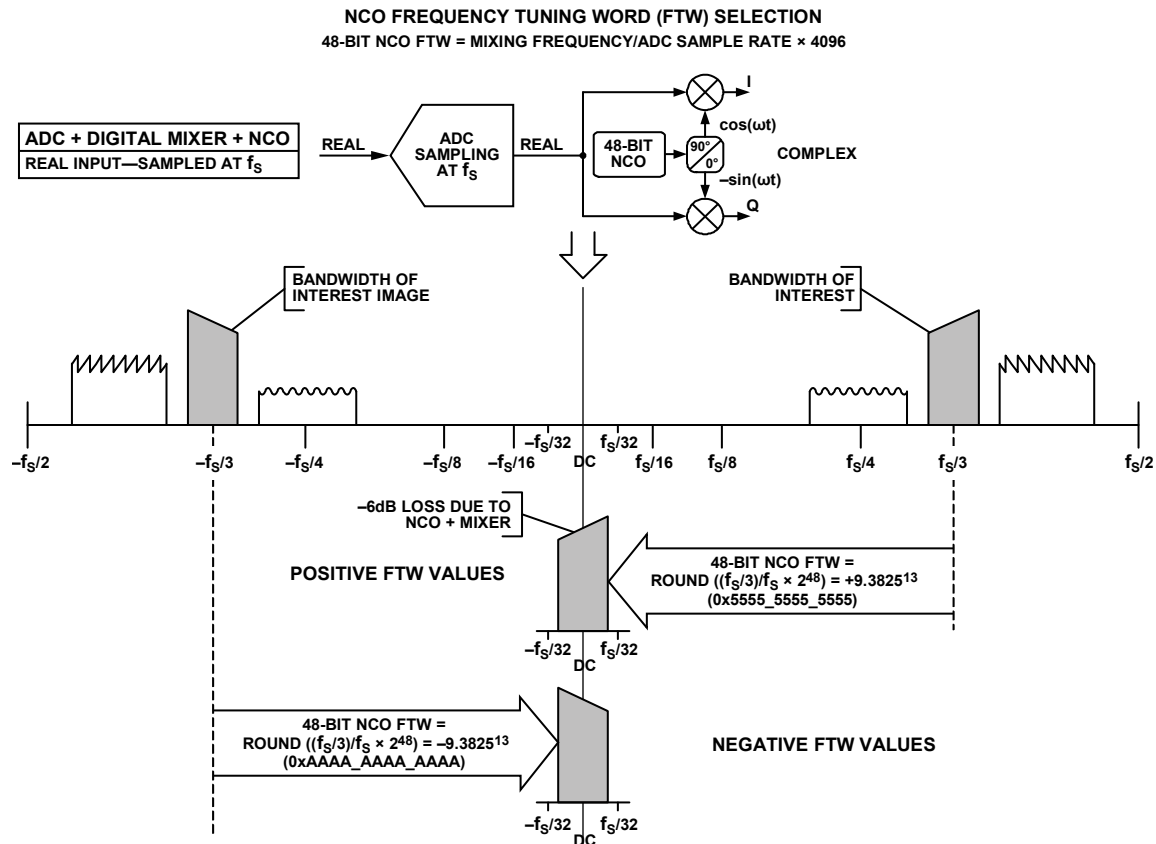

15547-081

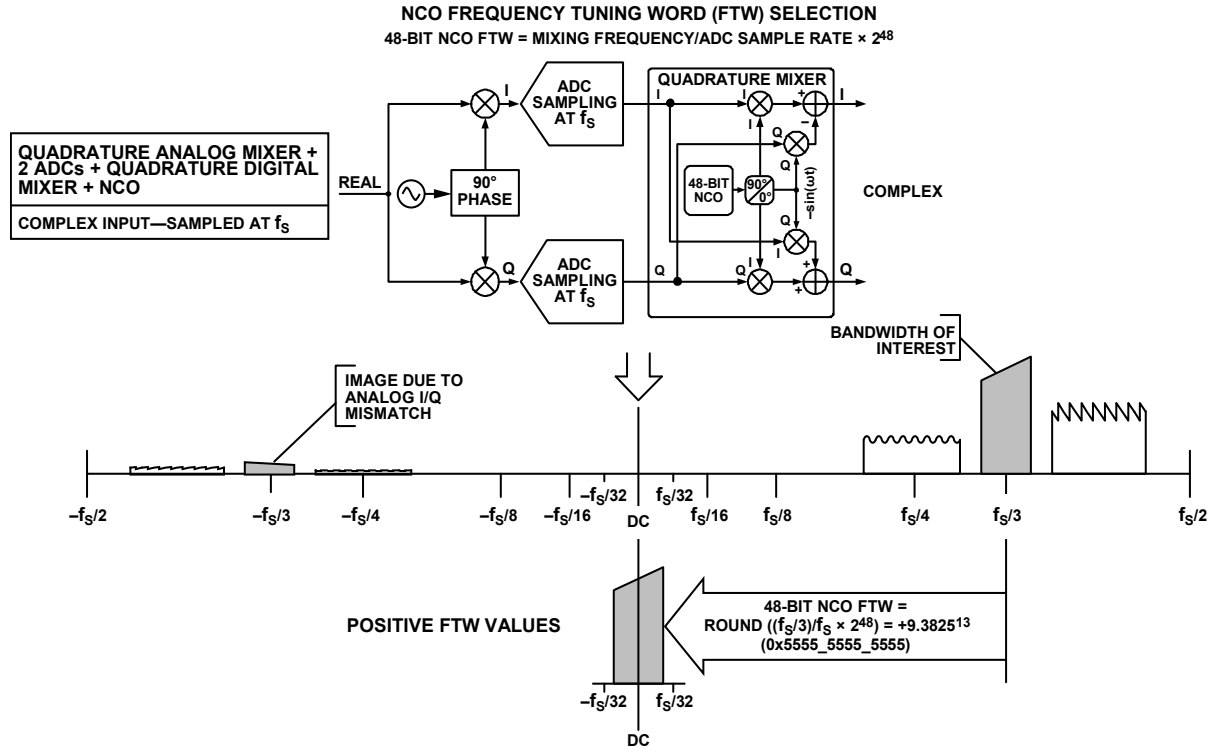

Figure 87. DDC NCO Frequency Tuning Word Selection—Complex Inputs

15547-082

**DDC NCO Description**

Each DDC contains one NCO. Each NCO enables the frequency translation process by creating a complex exponential frequency ( $e^{-j\omega t}$ ), which can be mixed with the input spectrum to translate the desired frequency band of interest to dc, where it can be filtered by the subsequent low-pass filter blocks to prevent aliasing.

When placed in variable IF mode, the NCO supports two different additional modes.

**DDC NCO Programmable Modulus Mode**

This mode supports >48-bit frequency tuning accuracy for applications that require exact rational (M/N) frequency synthesis at a single carrier frequency. In this mode, the NCO is set up by providing the following:

- 48-bit frequency tuning word (FTW)
- 48-bit Modulus A word (MAW)
- 48-bit Modulus B word (MBW)
- 48-bit phase offset word (POW)

**DDC NCO Coherent Mode**

This mode allows an infinite number of frequency hops where the phase is referenced to a single synchronization event at time 0. This mode is useful when phase coherency must be maintained when switching between different frequency bands. In this mode, the user can switch to any tuning frequency without the need to reset the NCO. Although only one FTW is required, the NCO contains 16 shadow registers for fast-switching applications. Selection of the shadow registers is controlled by the CMOS GPIO pins or through the register map of the SPI. In this mode, the NCO can be set up by providing the following:

- Up to sixteen 48-bit FTWs.
- Up to sixteen 48-bit POWs.
- The 48-bit MAW must be set to zero in coherent mode.

Figure 88 shows a block diagram of one NCO and its connection to the rest of the design. The coherent phase accumulator block contains the logic that allows an infinite number of frequency hops. The gray lines in Figure 88 represent SPI control lines.

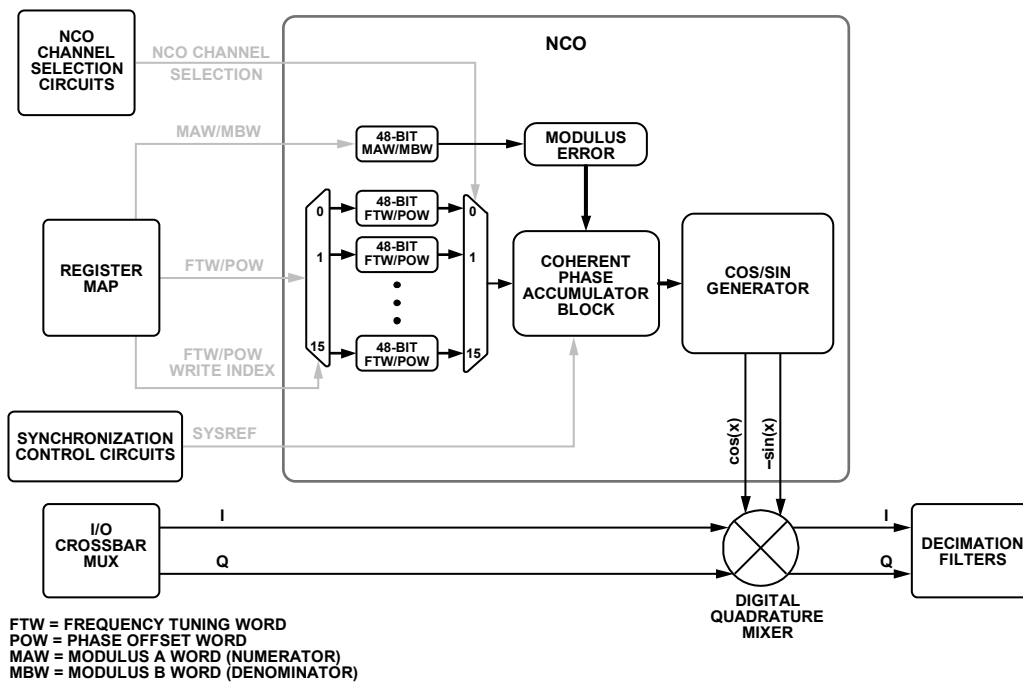

Figure 88. NCO + Mixer Block Diagram

15547-083

**NCO FTW/POW/MAW/MAB Description**

The NCO frequency value is determined by the following settings:

- 48-bit twos complement number entered in the FTW
- 48-bit unsigned number entered in the MAW
- 48-bit unsigned number entered in the MBW

Frequencies between  $-f_s/2$  and  $+f_s/2$  ( $f_s/2$  excluded) are represented using the following values:

- FTW = 0x8000\_0000\_0000 and MAW = 0x0000\_0000\_0000 represents a frequency of  $-f_s/2$ .
- FTW = 0x0000\_0000\_0000 and MAW = 0x0000\_0000\_0000 represents dc (frequency is 0 Hz).
- FTW = 0x7FFF\_FFFF\_FFFF and MAW = 0x0000\_0000\_0000 represents a frequency of  $+f_s/2$ .

**NCO FTW/POW/MAW/MAB Programmable Modulus Mode**

For programmable modulus mode, the MAW must be set to a nonzero value (not equal to 0x0000\_0000\_0000). This mode is only needed when frequency accuracy of >48 bits is required. One example of a rational frequency synthesis requirement that requires >48 bits of accuracy is a carrier frequency of 1/3 the sample rate. When frequency accuracy of  $\leq 48$  bits is required, coherent mode must be used (see the NCO FTW/POW/MAW/MAB Coherent Mode section).

In programmable modulus mode, the FTW, MAW, and MBW must satisfy the following four equations (for a detailed description of the programmable modulus feature, see the DDS architecture described in the [AN-953 Application Note](#)):

$$\frac{\text{mod}(f_c, f_s)}{f_s} = \frac{M}{N} = \frac{FTW + \frac{MAW}{MBW}}{2^{48}} \quad (1)$$

$$FTW = \text{floor}\left(2^{48} \frac{\text{mod}(f_c, f_s)}{f_s}\right) \quad (2)$$

$$MAW = \text{mod}(2^{48} \times M, N) \quad (3)$$

$$MBW = N \quad (4)$$

where:

$f_c$  is the desired carrier frequency.

$f_s$  is the ADC sampling frequency.

$M$  is the integer representing the rational numerator of the frequency ratio.

$N$  is the integer representing the rational denominator of the frequency ratio.

$FTW$  is the 48-bit twos complement number representing the NCO FTW.

$MAW$  is the 48-bit unsigned number representing the NCO MAW (must be  $< 2^{47}$ ).

$MBW$  is the 48-bit unsigned number representing the NCO MBW.

$\text{mod}(x)$  is a remainder function. For example,  $\text{mod}(110, 100) = 10$  and for negative numbers,  $\text{mod}(-32, 10) = -2$ .

$\text{floor}(x)$  is defined as the largest integer less than or equal to  $x$ .

For example,  $\text{floor}(3.6) = 3$ .

Note that Equation 1 to Equation 4 apply to the aliasing of signals in the digital domain (that is, aliasing introduced when digitizing analog signals).

$M$  and  $N$  are integers reduced to their lowest terms. MAW and MBW are integers reduced to their lowest terms. When MAW is set to zero, the programmable modulus logic is automatically disabled.

For example, if the ADC sampling frequency ( $f_s$ ) is 3000 MSPS and the carrier frequency ( $f_c$ ) is 1001.5 MHz, then,

$$\frac{\text{mod}(1001.5, 3000)}{3000} = \frac{M}{N} = \frac{2003}{6000}$$

$$FTW = \text{floor}\left(2^{48} \frac{\text{mod}(1001.5, 3000)}{3000}\right)$$

$$= 0x5576_19F0_FB38$$

$$MAW = \text{mod}(2^{48} \times 2003, 6000) = 0x0000_0000_0F80$$

$$MBW = 0x0000_0000_1770$$

The actual carrier frequency can be calculated based on the following equation:

$$f_{C\_ACTUAL} = \frac{FTW + \frac{MAW}{MBW} \times f_s}{2^{48}}$$

For the previous example, the actual carrier frequency ( $f_{C\_ACTUAL}$ ) is

$$f_{C\_ACTUAL} = \frac{0x5576_19F0_FB38 \times \frac{0x0000_0000_0F80}{0x0000_0000_1770}}{2^{48}}$$

$$= 1001.5\text{MHz}$$

A 48-bit POW is available for each NCO to create a known phase relationship between multiple chips or individual DDC channels inside the chip.

While in programmable modulus mode, the FTW and POW registers can be updated at any time while still maintaining deterministic phase results in the NCO. However, the following procedure must be followed to update the MAW and/or MBW registers to ensure proper operation of the NCO:

1. Write to the MAW and MBW registers for all the DDCs.
2. Synchronize the NCOs either through the DDC soft reset bit accessible through the SPI or through the assertion of the SYSREF $\pm$  pin (see the Memory Map section).

**NCO FTW/POW/MAW/MAB Coherent Mode**

For coherent mode, the NCO MAW must be set to zero (0x0000\_0000\_0000). In this mode, the NCO FTW can be calculated by the following equation:

$$FTW = \text{round}(2^{48} \frac{\text{mod}(f_c, f_s)}{f_s}) \tag{5}$$

where:

FTW is the 48-bit twos complement number representing the NCO FTW.

$f_s$  is the ADC sampling frequency.

$f_c$  is the desired carrier frequency.

mod( $x$ ) is a remainder function. For example mod(110,100) = 10 and for negative numbers, mod(-32,10) = -2.

round( $x$ ) is a rounding function. For example round(3.6) = 4 and for negative numbers, round(-3.4) = -3.

Note that Equation 5 applies to the aliasing of signals in the digital domain (that is, aliasing introduced when digitizing analog signals). The MAW must be set to zero to use coherent mode. When MAW is zero, the programmable modulus logic is automatically disabled.

For example, if the ADC sampling frequency ( $f_s$ ) is 3000 MSPS and the carrier frequency ( $f_c$ ) is 416.667 MHz, then,

$$\begin{aligned} NCO\_FTW &= \text{round}(2^{48} \frac{\text{mod}(416.667, 3000)}{3000}) \\ &= 0x2EC6\_C03A\_8E23 \end{aligned}$$

The actual carrier frequency can be calculated based on the following equation:

$$f_{C\_ACTUAL} = \frac{FTW \times f_s}{2^{48}}$$

For the previous example, the actual carrier frequency ( $f_{C\_ACTUAL}$ ) is

$$f_{C\_ACTUAL} = \frac{416.667 \times 3000}{2^{48}} = 416.66699 \text{ MHz}$$

A 48-bit POW is available for each NCO to create a known phase relationship between multiple chips or individual DDC channels inside the chip.

While in coherent mode, the FTW and POW registers can be updated at any time while still maintaining deterministic phase results in the NCO.

**NCO Channel Selection**

When configured in coherent mode, only one FTW is required in the NCO. In this mode, the user can switch to any tuning frequency without the need to reset the NCO by writing to the FTW directly. However, for fast-switching applications, where either all FTWs are known beforehand or it is possible to queue up the next set of FTWs, the NCO contains 16 additional shadow registers (see Figure 88). These shadow registers are hereafter referred to as the NCO channels.

Figure 89 shows a simplified block diagram of the NCO channel selection block. The gray lines in Figure 89 represent SPI control lines.

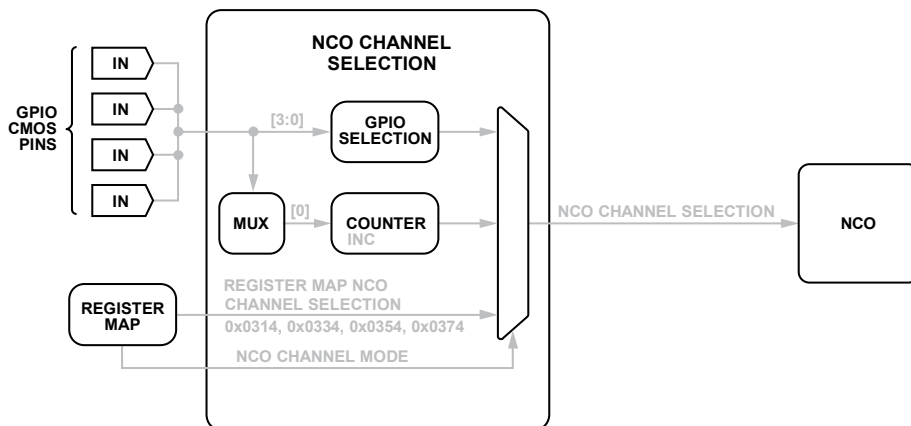

Figure 89. NCO Channel Selection Block

15547-084

Only one NCO channel is active at a time and NCO channel selection is controlled either by the CMOS GPIO pins or through the register map.

Each NCO channel selector supports three different modes, described as follows:

- GPIO level control mode. In this mode, the GPIO pins determine the exact NCO channel selected.
- GPIO edge control mode. A low to high transition on a single GPIO pin determines the exact NCO channel selected. The internal channel selection counter is reset by either SYSREF± or by the DDC soft reset.
- Register map mode. In this mode, the NCO channel selected is determined directly through the register map.

The following procedure must be followed to use GPIO level control mode for NCO channel selection:

1. Configure one or more GPIO pins as NCO channel selection inputs. The GPIO pins not configured as NCO channel selection inputs are internally tied low.
  - a. To use GPIO\_A0, write Bits[2:0] in Register 0x0040 to 0x6 and Bits[3:0] in Register 0x0041 to 0x0.
  - b. To use GPIO\_B0, write Bits[5:3] in Register 0x0040 to 0x6 and Bits[7:4] in Register 0x0041 to 0x0.
  - c. To use GPIO\_A1, write Bits[3:0] in Register 0x0042 to 0x0.
  - d. To use GPIO\_B1, write Bits[7:4] in Register 0x0042 to 0x0.
2. Configure the NCO channel selector in GPIO level control mode by setting Bits[7:4] in the NCO control registers (Register 0x0314, Register 0x0334, Register 0x0354, and Register 0x0374) to 0x1 through 0x6, depending on the desired GPIO pin order.
3. Select the desired NCO channel through the GPIO pins.

The following procedure must be followed to use GPIO edge control mode for NCO channel selection:

1. Configure one or more GPIO pins as NCO channel selection inputs.
  - a. To use GPIO\_A0, write Bits[2:0] in Register 0x0040 to 0x6 and Bits[3:0] in Register 0x0041 to 0x0.
  - b. To use GPIO\_B0, write Bits[5:3] in Register 0x0040 to 0x6 and Bits[7:4] in Register 0x0041 to 0x0.
  - c. To use GPIO\_A1, write Bits[3:0] in Register 0x0042 to 0x0.
  - d. To use GPIO\_B1, write Bits[7:4] in Register 0x0042 to 0x0.
2. Configure the NCO channel selector in GPIO edge control mode by setting Bits[7:4] in the NCO control registers (Register 0x0314, Register 0x0334, Register 0x0354, and Register 0x0374) to 0x8 through 0xB, depending on the desired GPIO pin.
3. Configure the wrap point for the NCO channel selection by setting Bits[3:0] in the NCO control registers (Register 0x0314, Register 0x0334, Register 0x0354, and Register 0x0374). A value of 4 causes the channel selection to wrap at Channel 4 (for example, 0, 1, 2, 3, 4, 0, 1, 2, 3, 4).
4. Transition the selected GPIO pin from low to high to increment the NCO channel selection.

Figure 90 shows an example use case for coherent mode using three NCO channels. In this example, NCO Channel 0 is actively downconverting Bandwidth 0 (B0), while NCO Channel 1 and Channel 2 are in standby mode and are tuned to Bandwidth 1 and Bandwidth 2 (B1 and B2), respectively.

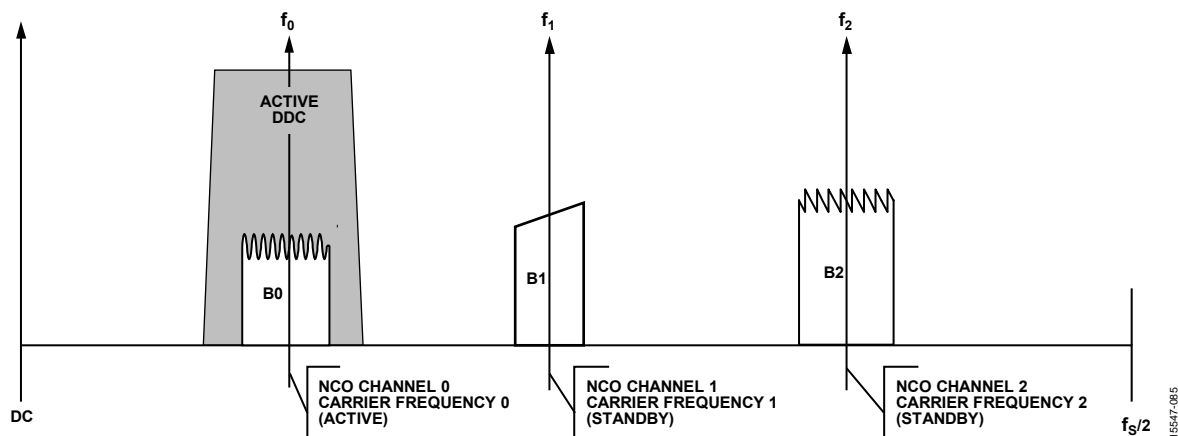

Figure 90. NCO Coherent Mode with Three NCO Channels (B0 Selected)



The phase coherent NCO switching feature allows an infinite number of frequency hops that are all phase coherent. The initial phase of the NCO is established at time,  $t_0$ , from SYSREF± synchronization. Switching the NCO FTW does not affect the phase. With this feature, only one FTW is required, but the user may wish to use all 16 channels to queue up the next hop.

After SYSREF± synchronization at startup, all NCOs across multiple chips are inherently synchronized.

### Setting Up the Multichannel NCO Feature

The first step to configure the multichannel NCO is to program the FTWs. The AD9208 memory map has an FTW index register for each DDC. This index determines which NCO channel receives the FTW from the register map. The following sequence describes the method for programming the FTWs:

1. Write the FTW index register with the desired DDC channel.
2. Write the FTW with the desired value. This value is applied to the NCO channel index mentioned in Step 1.
3. Repeat Step 1 and Step 2 for other NCO channels.

After setting the FTWs, the user must then select an active NCO channel. This selection can be performed either through the SPI registers or through the external GPIO pins. The following sequence describes the method for selecting the active NCO channel using the SPI:

1. Set the NCO channel select mode bits (Bits[7:4] in Register 0x0314, Register 0x0334, Register 0x0354, and Register 0x0374) to 0x0 to enable SPI selection.
2. Choose the active NCO channel using Bits[3:0] in Register 0x0314, Register 0x0334, Register 0x0354, and Register 0x0374.

The following sequence describes the method for selecting the active NCO channel using the GPIO CMOS pins:

1. Set the NCO channel select mode bits (Bits[7:4] in Register 0x0314, Register 0x0334, Register 0x0354, and Register 0x0374) to a nonzero value to enable GPIO pin selection.
2. Configure the GPIO pins as NCO channel selection inputs by writing to Register 0x0040, Register 0x0041, and Register 0x0042.
3. NCO switching is performed by externally controlling the GPIO CMOS pins.

### NCO Synchronization

Each NCO contains a separate phase accumulator word (PAW). The initial reset value of each PAW is set to zero and incremented every clock cycle. The instantaneous phase of the NCO is calculated using the PAW, FTW, MAW, MBW, and POW. Due to this architecture, the FTW and POW registers can be updated at any time while still maintaining deterministic phase results in the PAW of the NCO.

Two methods can be used to synchronize multiple PAWs within the chip:

- Using the SPI. Use the DDC soft reset bit in the DDC synchronization control register (Register 0x0300, Bit 4) to reset all the PAWs in the chip. This reset is accomplished by setting the DDC soft reset bit high, and then setting this bit low. Note that this method can only be used to synchronize DDC channels within the same chip.
- Using the SYSREF± pin. When the SYSREF± pin is enabled in the SYSREF control registers (Register 0x0120 and Register 0x0121), and the DDC synchronization is enabled in the DDC synchronization control register (Register 0x0300, Bits[1:0]), any subsequent SYSREF± event resets all the PAWs in the chip. Note that this method can be used to synchronize DDC channels within the same chip or DDC channels within separate chips.

### NCO Multichip Synchronization

In some applications, it is necessary to synchronize all the NCOs and local multiframe clocks (LMFCs) within multiple devices in a system. For applications requiring multiple NCO tuning frequencies in the system, a designer likely needs to generate a single SYSREF pulse at all devices simultaneously. For many systems, generating or receiving a single-shot SYSREF pulse at all devices is challenging because of the following factors:

- Enabling or disabling the SYSREF pulse is often an asynchronous event.
- Not all clock generation chips support this feature.

For these reasons, the AD9208 contains a synchronization triggering mechanism that allows the following:

- Multichip synchronization of all NCOs and LMFCs at system startup.
- Multichip synchronization of all NCOs after applying new tuning frequencies during normal operation.

The synchronization triggering mechanism uses a master/slave arrangement, as shown in Figure 91.

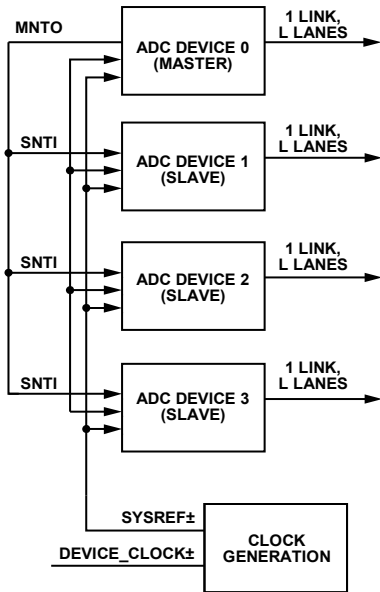

MNT0 = MASTER NEXT TRIGGER OUTPUT (CMOS)  
 SNTI = SLAVE NEXT TRIGGER INPUT (CMOS)

15547-086

Figure 91. System Using Master/Slave Synchronization Triggering

Each device has an internal next synchronization trigger enable (NSTE) signal that controls whether the next SYSREF signal causes a synchronization event. Slave ADC devices must source their NSTE from an external slave next trigger input (SNTI) pin. Master devices can either use an external master next trigger output (MNT0) pin (default setting), or use an external SNTI pin.

See Table 46 (Register 0x0041 and Register 0x0042) to configure the FD/GPIO pins for this operation.

**NCO Multichip Synchronization at Startup**

Figure 92 shows a timing diagram along with the required sequence of events for NCO multichip synchronization using triggering and SYSREF at startup. Using this startup sequence synchronizes all the NCOs and LMFCs in the system at once.

**NCO Multichip Synchronization During Normal Operation**

See the Setting Up the Multichannel NCO Feature section.

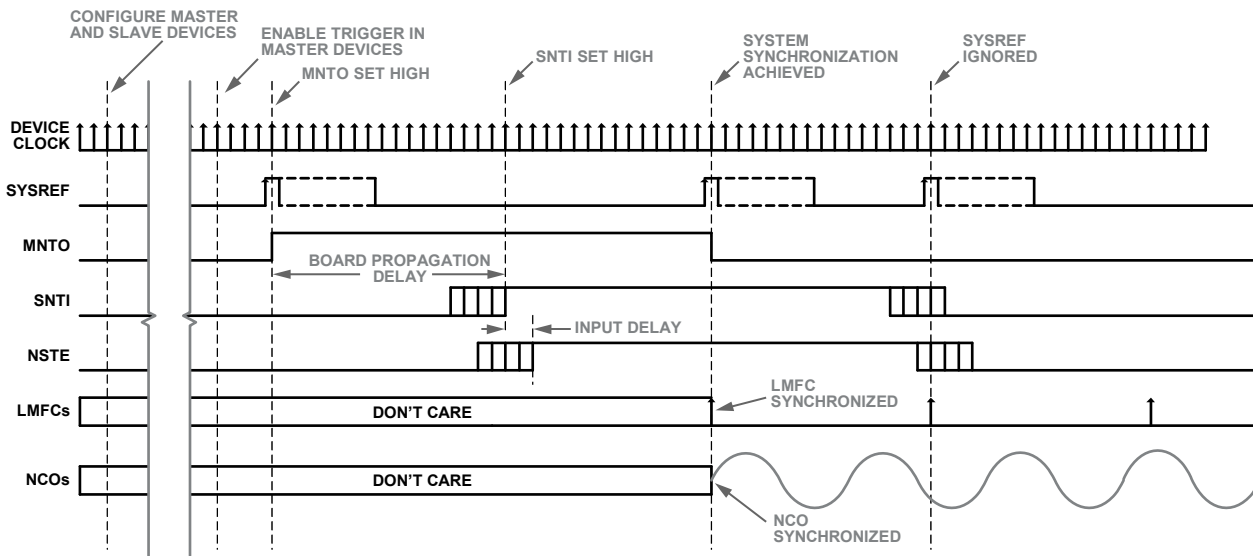

MNT0 = MASTER NEXT TRIGGER OUTPUT (CMOS)  
 SNTI = SLAVE NEXT TRIGGER INPUT (CMOS)  
 NSTE = NEXT SYNCHRONIZATION TRIGGER ENABLE  
 LMFC = LOCAL MULTIFRAME CLOCK  
 NCO = NUMERICALLY CONTROLLED OSCILLATOR

15547-087

Figure 92. NCO Multichip Synchronization at Startup (Using Triggering and SYSREF)

**DDC Mixer Description**

When not bypassed (Register 0x0200 ≠ 0x00), the digital quadrature mixer performs a similar operation to an analog quadrature mixer. It performs the downconversion of input signals (real or complex) by using the NCO frequency as a local oscillator. For real input signals, a real mixer operation (with two multipliers) is performed. For complex input signals, a complex mixer operation (with four multipliers and two adders) is performed. The selection of real or complex inputs can be controlled individually for each DDC block using Bit 7 of the DDC control registers (Register 0x0310, Register 0x0330, Register 0x0350, and Register 0x0370).

**DDC NCO + Mixer Loss and SFDR**

When mixing a real input signal down to baseband, -6 dB of loss is introduced in the signal due to filtering of the negative image. An additional -0.05 dB of loss is introduced by the NCO. The total loss of a real input signal mixed down to baseband is -6.05 dB. For this reason, it is recommended that the user compensate for this loss by enabling the 6 dB of gain in the gain stage of the DDC to recenter the dynamic range of the signal within the full scale of the output bits (see the DDC Gain Stage (Optional) section).

When mixing a complex input signal (where I and Q DDC inputs come from the different ADCs) down to baseband, the

maximum value each I/Q sample is able to reach is  $1.414 \times$  full scale, after the sample passes through the complex mixer. To avoid overrange of the I/Q samples and to keep the data bit widths aligned with real mixing, -3.06 dB of loss is introduced in the mixer for complex signals. An additional -0.05 dB of loss is introduced by the NCO. The total loss of a complex input signal mixed down to baseband is -3.11 dB.

The worst case spurious signal from the NCO is greater than 102 dBc SFDR for all output frequencies.

**DDC DECIMATION FILTERS**

After the frequency translation stage, there are multiple decimation filter stages that reduce the output data rate. After the carrier of interest is tuned down to dc (carrier frequency = 0 Hz), these filters efficiently lower the sample rate, while providing sufficient alias rejection from unwanted adjacent carriers around the bandwidth of interest.

Figure 93 shows a simplified block diagram of the decimation filter stage, and Table 16 describes the filter characteristics of the different finite impulse response (FIR) filter blocks.

Table 17 and Table 18 show the different filter configurations selectable by including different filters. In all cases, the DDC filtering stage provides 80% of the available output bandwidth,  $< \pm 0.005$  dB of passband ripple and  $> 100$  dB of stop band alias rejection.

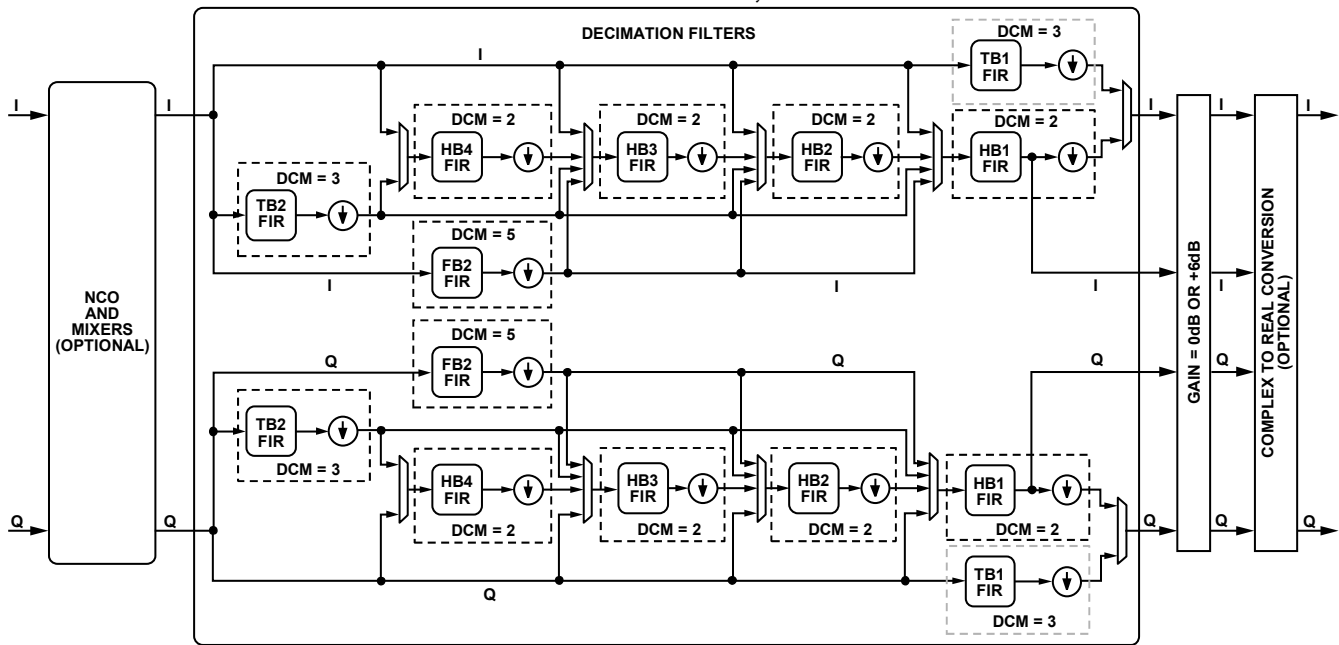

FIR = FINITE IMPULSE RESPONSE FILTER  
DCM = DECIMATION

NOTES  
1. TB1 IS ONLY SUPPORTED IN DDC0 AND DDC1

Figure 93. DDC Decimation Filter Block Diagram

15547-088

Table 16. DDC Decimation Filter Characteristics

| Filter Name      | Filter Type  | Decimation Ratio | Pass Band (rad/sec) | Stop Band (rad/sec) | Pass-Band Ripple (dB) | Stop-Band Attenuation (dB) |
|------------------|--------------|------------------|---------------------|---------------------|-----------------------|----------------------------|
| HB4              | FIR low-pass | 2                | $0.1 \times \pi/2$  | $1.9 \times \pi/2$  | $<\pm 0.001$          | $>100$                     |
| HB3              | FIR low-pass | 2                | $0.2 \times \pi/2$  | $1.8 \times \pi/2$  | $<\pm 0.001$          | $>100$                     |
| HB2              | FIR low-pass | 2                | $0.4 \times \pi/2$  | $1.6 \times \pi/2$  | $<\pm 0.001$          | $>100$                     |
| HB1              | FIR low-pass | 2                | $0.8 \times \pi/2$  | $1.2 \times \pi/2$  | $<\pm 0.001$          | $>100$                     |
| TB2              | FIR low-pass | 3                | $0.4 \times \pi/3$  | $1.6 \times \pi/3$  | $<\pm 0.002$          | $>100$                     |
| TB1 <sup>1</sup> | FIR low-pass | 3                | $0.8 \times \pi/3$  | $1.2 \times \pi/3$  | $<\pm 0.005$          | $>100$                     |
| FB2              | FIR low-pass | 5                | $0.4 \times \pi/5$  | $1.6 \times \pi/5$  | $<\pm 0.001$          | $>100$                     |

<sup>1</sup> TB1 is only supported in DDC0 and DDC1.

Table 17. DDC Filter Configurations<sup>1</sup>

| ADC Sample Rate | DDC Filter Configuration     | Real (I) Output  |                    | Complex (I/Q) Outputs |   | Alias Protected Bandwidth | Ideal <sup>2</sup> SNR Improvement (dB) |
|-----------------|------------------------------|------------------|--------------------|-----------------------|---|---------------------------|---|
|                 |                              | Decimation Ratio | Sample Rate        | Decimation Ratio      | Sample Rate                                     |                           |   |
| f <sub>s</sub>  | HB1                          | 1                | f <sub>s</sub>     | 2                     | f <sub>s</sub> /2 (I) + f <sub>s</sub> /2 (Q)   | f <sub>s</sub> /2 × 80%   | 1                                       |
|                 | TB1 <sup>3</sup>             | N/A              | N/A                | 3                     | f <sub>s</sub> /3 (I) + f <sub>s</sub> /3 (Q)   | f <sub>s</sub> /3 × 80%   | 2.7                                     |
|                 | HB2 + HB1                    | 2                | f <sub>s</sub> /2  | 4                     | f <sub>s</sub> /4 (I) + f <sub>s</sub> /4 (Q)   | f <sub>s</sub> /4 × 80%   | 4                                       |
|                 | TB2 + HB1                    | 3                | f <sub>s</sub> /3  | 6                     | f <sub>s</sub> /6 (I) + f <sub>s</sub> /6 (Q)   | f <sub>s</sub> /6 × 80%   | 5.7                                     |
|                 | HB3 + HB2 + HB1              | 4                | f <sub>s</sub> /4  | 8                     | f <sub>s</sub> /8 (I) + f <sub>s</sub> /8 (Q)   | f <sub>s</sub> /8 × 80%   | 7                                       |
|                 | FB2 + HB1                    | 5                | f <sub>s</sub> /5  | 10                    | f <sub>s</sub> /10 (I) + f <sub>s</sub> /10 (Q) | f <sub>s</sub> /10 × 80%  | 8                                       |
|                 | TB2 + HB2 + HB1              | 6                | f <sub>s</sub> /6  | 12                    | f <sub>s</sub> /12 (I) + f <sub>s</sub> /12 (Q) | f <sub>s</sub> /12 × 80%  | 8.8                                     |
|                 | FB2 + TB1 <sup>3</sup>       | N/A              | N/A                | 15                    | f <sub>s</sub> /15 (I) + f <sub>s</sub> /15 (Q) | f <sub>s</sub> /15 × 80%  | 9.7                                     |
|                 | HB4 + HB3 + HB2 + HB1        | 8                | f <sub>s</sub> /8  | 16                    | f <sub>s</sub> /16 (I) + f <sub>s</sub> /16 (Q) | f <sub>s</sub> /16 × 80%  | 10                                      |
|                 | FB2 + HB2 + HB1              | 10               | f <sub>s</sub> /10 | 20                    | f <sub>s</sub> /20 (I) + f <sub>s</sub> /20 (Q) | f <sub>s</sub> /20 × 80%  | 11                                      |
|                 | TB2 + HB3 + HB2 + HB1        | 12               | f <sub>s</sub> /12 | 24                    | f <sub>s</sub> /24 (I) + f <sub>s</sub> /24 (Q) | f <sub>s</sub> /24 × 80%  | 11.8                                    |
|                 | HB2 + FB2 + TB1 <sup>3</sup> | N/A              | N/A                | 30                    | f <sub>s</sub> /30 (I) + f <sub>s</sub> /30 (Q) | f <sub>s</sub> /30 × 80%  | 12.7                                    |
|                 | FB2 + HB3 + HB2 + HB1        | 20               | f <sub>s</sub> /20 | 40                    | f <sub>s</sub> /40 (I) + f <sub>s</sub> /40 (Q) | f <sub>s</sub> /40 × 80%  | 14                                      |
|                 | TB2 + HB4 + HB3 + HB2 + HB1  | 24               | f <sub>s</sub> /24 | 48                    | f <sub>s</sub> /48 (I) + f <sub>s</sub> /48 (Q) | f <sub>s</sub> /48 × 80%  | 14.8                                    |

<sup>1</sup> N/A means not applicable.

<sup>2</sup> Ideal SNR improvement due to oversampling + filtering =  $10\log(\text{bandwidth}/f_s/2)$ .

<sup>3</sup> TB1 is only supported in in DDC0 and DDC1.

Table 18. DDC Filter Configurations (f<sub>s</sub> = 3000 MSPS)<sup>1</sup>

| ADC Sample Rate (MSPS) | DDC Filter Configuration     | Real (I) Output  |                    | Complex (I/Q) Outputs |                       | Alias Protected Bandwidth (MHz) |
|------------------------|------------------------------|------------------|--------------------|-----------------------|-----------------------|---------------------------------|
|                        |                              | Decimation Ratio | Sample Rate (MSPS) | Decimation Ratio      | Sample Rate (MSPS)    |                                 |
| 3000                   | HB1                          | 1                | 3000               | 2                     | 1500 (I) + 1500 (Q)   | 1200                            |
|                        | TB1 <sup>2</sup>             | N/A              | N/A                | 3                     | 1000 (I) + 1000 (Q)   | 800                             |
|                        | HB2 + HB1                    | 2                | 1500               | 4                     | 750 (I) + 750 (Q)     | 600                             |
|                        | TB2 + HB1                    | 3                | 1000               | 6                     | 500 (I) + 500 (Q)     | 400                             |
|                        | HB3 + HB2 + HB1              | 4                | 750                | 8                     | 375 (I) + 375 (Q)     | 300                             |
|                        | FB2 + HB1                    | 5                | 600                | 10                    | 300 (I) + 300 (Q)     | 240                             |
|                        | TB2 + HB2 + HB1              | 6                | 500                | 12                    | 250 (I) + 250 (Q)     | 200                             |
|                        | FB2 + TB1 <sup>2</sup>       | N/A              | N/A                | 15                    | 200 (I) + 200 (Q)     | 160                             |
|                        | HB4 + HB3 + HB2 + HB1        | 8                | 375                | 16                    | 187.5 (I) + 187.5 (Q) | 150                             |
|                        | FB2 + HB2 + HB1              | 10               | 300                | 20                    | 150 (I) + 150 (Q)     | 120                             |
|                        | TB2 + HB3 + HB2 + HB1        | 12               | 250                | 24                    | 125 (I) + 125 (Q)     | 100                             |
|                        | HB2 + FB2 + TB1 <sup>2</sup> | N/A              | N/A                | 30                    | 100 (I) + 100 (Q)     | 80                              |
|                        | FB2 + HB3 + HB2 + HB1        | 20               | 150                | 40                    | 75 (I) + 75 (Q)       | 60                              |
|                        | TB2 + HB4 + HB3 + HB2 + HB1  | 24               | 125                | 48                    | 62.5 (I) + 62.5 (Q)   | 50                              |

<sup>1</sup> N/A means not applicable.

<sup>2</sup> TB1 is only supported in in DDC0 and DDC1.

**HB4 Filter Description**

The first decimate by 2, half-band, low-pass, FIR filter (HB4) uses an 11-tap, symmetrical, fixed coefficient filter implementation that is optimized for low power consumption. The HB4 filter is only used when complex outputs (decimate by 16) or real outputs (decimate by 8) are enabled; otherwise, it is bypassed. Table 19 and Figure 94 show the coefficients and response of the HB4 filter.

**Table 19. HB4 Filter Coefficients**

| HB4 Coefficient Number | Normalized Coefficient | Decimal Coefficient (15-Bit) |
|------------------------|------------------------|------------------------------|
| C1, C11                | 0.006042               | 99                           |
| C2, C10                | 0                      | 0                            |
| C3, C9                 | -0.049377              | -809                         |
| C4, C8                 | 0                      | 0                            |
| C5, C7                 | 0.293304               | 4806                         |
| C6                     | 0.5                    | 8192                         |

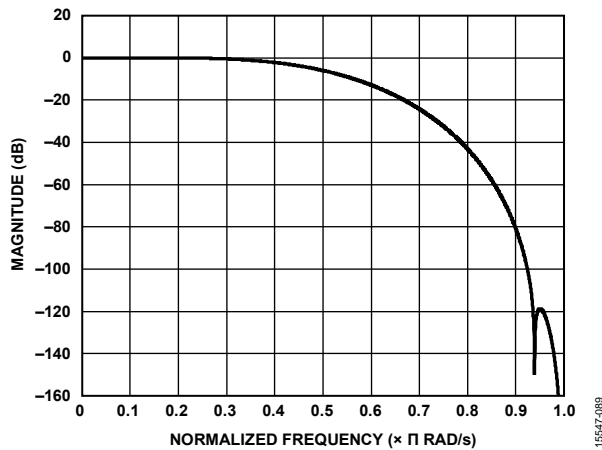

Figure 94. HB4 Filter Response

**HB3 Filter Description**

The second decimate by 2, half-band, low-pass, FIR filter (HB3) uses an 11-tap, symmetrical, fixed coefficient filter implementation that is optimized for low power consumption. The HB3 filter is only used when complex outputs (decimate by 8 or 16) or real outputs (decimate by 4 or 8) are enabled; otherwise, it is bypassed. Table 20 and Figure 95 show the coefficients and response of the HB3 filter.

**Table 20. HB3 Filter Coefficients**

| HB3 Coefficient Number | Normalized Coefficient | Decimal Coefficient (17-Bit) |
|------------------------|------------------------|------------------------------|
| C1, C11                | 0.006637               | 435                          |
| C2, C10                | 0                      | 0                            |
| C3, C9                 | -0.051055              | -3346                        |
| C4, C8                 | 0                      | 0                            |
| C5, C7                 | 0.294418               | 19295                        |
| C6                     | 0.500000               | 65,536                       |

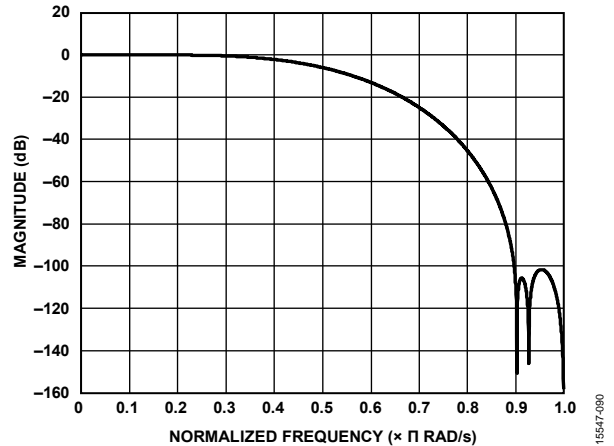

Figure 95. HB3 Filter Response

**HB2 Filter Description**

The third decimate by 2, half-band, low-pass, FIR filter (HB2) uses a 19-tap, symmetrical, fixed coefficient filter implementation that is optimized for low power consumption.

The HB2 filter is only used when complex or real outputs (decimate by 4, 8, or 16) is enabled; otherwise, it is bypassed.

Table 21 and Figure 96 show the coefficients and response of the HB2 filter.

**Table 21. HB2 Filter Coefficients**

| HB2 Coefficient Number | Normalized Coefficient | Decimal Coefficient (18-Bit) |
|------------------------|------------------------|------------------------------|
| C1, C19                | 0.000671               | 88                           |
| C2, C18                | 0                      | 0                            |
| C3, C17                | -0.005325              | -698                         |
| C4, C16                | 0                      | 0                            |
| C5, C15                | 0.022743               | 2981                         |
| C6, C14                | 0                      | 0                            |
| C7, C13                | -0.074180              | -9723                        |
| C8, C12                | 0                      | 0                            |
| C9, C11                | 0.306091               | 40120                        |
| C10                    | 0.5                    | 65536                        |

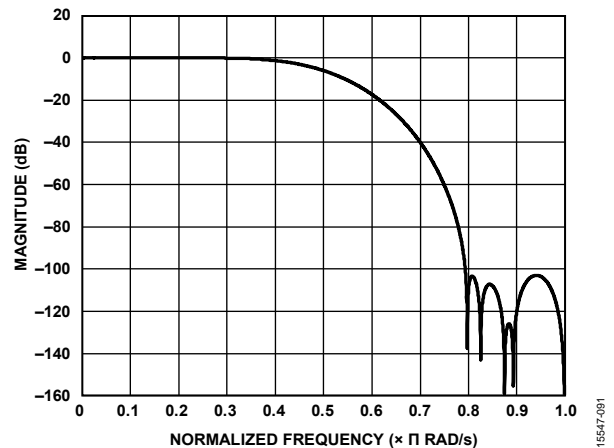

Figure 96. HB2 Filter Response

**HB1 Filter Description**

The fourth and final decimate by 2, half-band, low-pass, FIR filter (HB1) uses a 63-tap, symmetrical, fixed coefficient filter implementation that is optimized for low power consumption. The HB1 filter is always enabled and cannot be bypassed. Table 22 and Figure 97 show the coefficients and response of the HB1 filter.

**Table 22. HB1 Filter Coefficients**

| HB1 Coefficient Number | Normalized Coefficient | Decimal Coefficient (20-Bit) |
|------------------------|------------------------|------------------------------|
| C1, C63                | -0.000019              | -10                          |
| C2, C62                | 0                      | 0                            |
| C3, C61                | 0.000072               | 38                           |
| C4, C60                | 0                      | 0                            |
| C5, C59                | -0.000195              | -102                         |
| C6, C58                | 0                      | 0                            |
| C7, C57                | 0.000443               | 232                          |
| C8, C56                | 0                      | 0                            |
| C9, C55                | -0.000891              | -467                         |
| C10, C54               | 0                      | 0                            |
| C11, C53               | 0.001644               | 862                          |
| C12, C52               | 0                      | 0                            |
| C13, C51               | -0.00284               | -1489                        |
| C14, C50               | 0                      | 0                            |
| C15, C49               | 0.004654               | 2440                         |
| C16, C48               | 0                      | 0                            |
| C17, C47               | -0.007311              | -3833                        |
| C18, C46               | 0                      | 0                            |
| C19, C45               | 0.011122               | 5831                         |
| C20, C44               | 0                      | 0                            |
| C21, C43               | -0.016554              | -8679                        |
| C22, C42               | 0                      | 0                            |
| C23, C41               | 0.02442                | 12803                        |
| C24, C40               | 0                      | 0                            |
| C25, C39               | -0.036404              | -19086                       |
| C26, C38               | 0                      | 0                            |
| C27, C37               | 0.056866               | 29814                        |
| C28, C36               | 0                      | 0                            |
| C29, C35               | -0.101892              | -53421                       |
| C30, C34               | 0                      | 0                            |
| C31, C33               | 0.316883               | 166138                       |
| C32                    | 0.5                    | 262144                       |

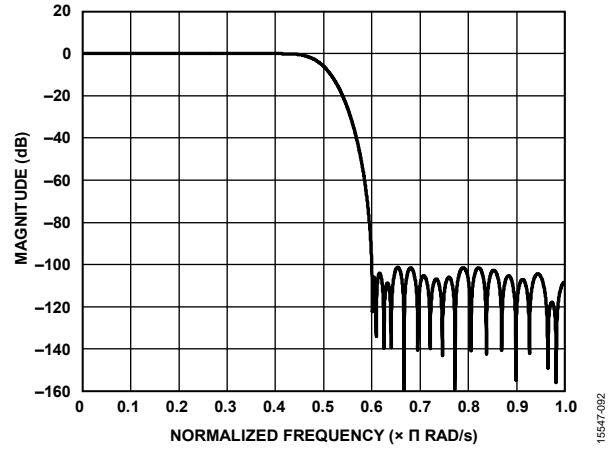

Figure 97. HB1 Filter Response

**TB2 Filter Description**

The TB2 uses a 26-tap, symmetrical, fixed coefficient filter implementation that is optimized for low power consumption. The TB2 filter is only used when decimation ratios of 6, 12, or 24 are required. Table 23 and Figure 94 show the coefficients and response of the TB2 filter.

**Table 23. TB2 Filter Coefficients**

| TB2 Coefficient Number | Normalized Coefficient | Decimal Coefficient (19-Bit) |
|------------------------|------------------------|------------------------------|
| C1, C26                | -0.000190              | -50                          |
| C2, C25                | -0.000793              | 208                          |
| C3, C24                | -0.00113               | -298                         |
| C4, C23                | 0.000915               | 240                          |
| C5, C22                | 0.006290               | 1649                         |
| C6, C21                | 0.009822               | 2575                         |
| C7, C20                | 0.000915               | 240                          |
| C8, C19                | -0.023483              | -6156                        |
| C9, C18                | -0.043151              | -11312                       |
| C10, C17               | -0.019317              | -5064                        |
| C11, C16               | 0.071327               | 18698                        |
| C12, C15               | 0.201171               | 52736                        |
| C13, C14               | 0.297756               | 78055                        |

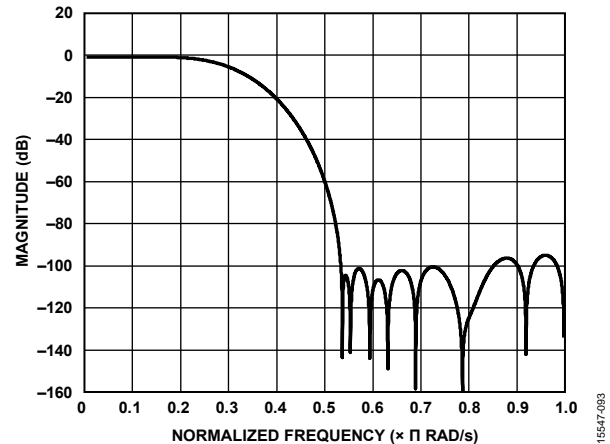

Figure 98. TB2 Filter Response

**TB1 Filter Description**

The TB1 decimate by 3, low-pass, FIR filter uses a 76-tap, symmetrical, fixed coefficient filter implementation. Table 24 shows the TB1 filter coefficients, and Figure 99 shows the TB1 filter response. TB1 is only supported in DDC0 and DDC1.

**Table 24. TB1 Filter Coefficients**

| TB1 Coefficient Number | Decimal Coefficient | Quantized Coefficient (22-Bit) |
|------------------------|---------------------|--------------------------------|
| 1, 96                  | -0.000023           | -96                            |
| 2, 75                  | -0.000053           | -224                           |
| 3, 74                  | -0.000037           | -156                           |
| 4, 73                  | 0.000090            | 379                            |
| 5, 72                  | 0.000291            | 1220                           |
| 6, 71                  | 0.000366            | 1534                           |
| 7, 70                  | 0.000095            | 398                            |
| 8, 69                  | -0.000463           | -1940                          |
| 9, 68                  | -0.000822           | -3448                          |
| 10, 67                 | -0.000412           | -1729                          |
| 11, 66                 | 0.000739            | 3100                           |
| 12, 65                 | 0.001665            | 6984                           |
| 13, 64                 | 0.001132            | 4748                           |
| 14, 63                 | -0.000981           | -4114                          |
| 15, 62                 | -0.002961           | -12418                         |
| 16, 61                 | -0.002438           | -10226                         |
| 17, 60                 | 0.001087            | 4560                           |
| 18, 59                 | 0.004833            | 20272                          |
| 19, 58                 | 0.004614            | 19352                          |
| 20, 57                 | -0.000871           | -3652                          |
| 21, 56                 | -0.007410           | -31080                         |
| 22, 55                 | -0.008039           | -33718                         |
| 23, 54                 | 0.000053            | 222                            |
| 24, 53                 | 0.010874            | 45608                          |
| 25, 52                 | 0.013313            | 55840                          |
| 26, 51                 | 0.001817            | 7620                           |
| 27, 50                 | -0.015579           | -65344                         |
| 28, 49                 | -0.021590           | -90556                         |
| 29, 48                 | -0.005603           | -23502                         |
| 30, 47                 | 0.022451            | 94167                          |
| 31, 46                 | 0.035774            | 150046                         |
| 32, 45                 | 0.013541            | 56796                          |
| 33, 44                 | -0.034655           | -145352                        |
| 34, 43                 | -0.066549           | -279128                        |
| 35, 42                 | -0.035213           | -147694                        |
| 36, 41                 | 0.071220            | 298720                         |
| 37, 40                 | 0.210777            | 884064                         |
| 38, 39                 | 0.309200            | 1296880                        |

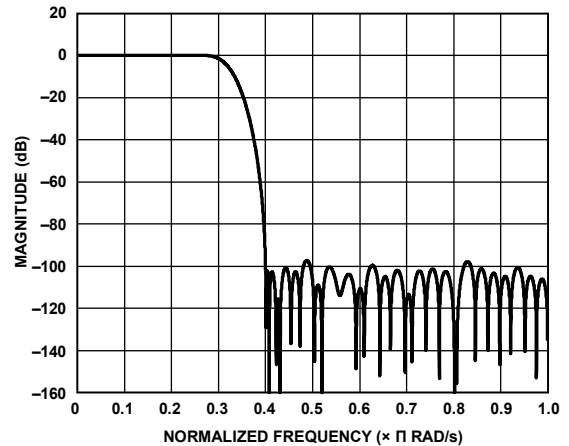

Figure 99. TB1 Filter Response

15647-084

**FB2 Filter Description**

The FB2 decimate by 5, low-pass, FIR filter uses a 48-tap, symmetrical, fixed coefficient filter implementation. Table 24 shows the FB2 filter coefficients, and Figure 100 shows the FB2 filter response.

**Table 25. FB2 Filter Coefficients**

| FB2 Coefficient Number | Decimal Coefficient | Quantized Coefficient (21-Bit) |
|------------------------|---------------------|--------------------------------|
| 1, 48                  | 0.000007            | 7                              |
| 2, 47                  | -0.000004           | -4                             |
| 3, 46                  | -0.000069           | -72                            |
| 4, 45                  | -0.000244           | -256                           |
| 5, 44                  | -0.000544           | -570                           |
| 6, 43                  | -0.000870           | -912                           |
| 7, 42                  | -0.000962           | -1009                          |
| 8, 41                  | -0.000448           | -470                           |
| 9, 40                  | 0.000977            | 1024                           |
| 10, 39                 | 0.003237            | 3394                           |
| 11, 38                 | 0.005614            | 5887                           |
| 12, 37                 | 0.006714            | 7040                           |
| 13, 36                 | 0.004871            | 5108                           |
| 14, 35                 | -0.001011           | -1060                          |
| 15, 34                 | -0.010456           | -10964                         |
| 16, 33                 | -0.020729           | -21736                         |
| 17, 32                 | -0.026978           | -28288                         |
| 18, 31                 | -0.023453           | -24592                         |
| 19, 30                 | -0.005608           | -5880                          |
| 20, 29                 | 0.027681            | 29026                          |
| 21, 28                 | 0.072720            | 76252                          |
| 22, 27                 | 0.121223            | 127112                         |
| 23, 26                 | 0.162346            | 170232                         |
| 24, 25                 | 0.185959            | 194992                         |

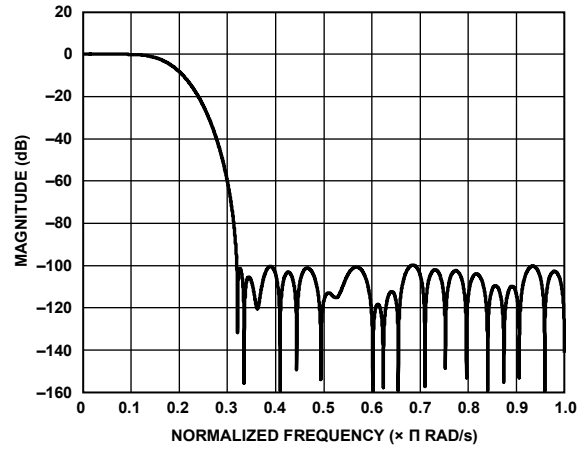

Figure 100. FB2 Filter Response

15547-095



**DDC GAIN STAGE**

Each DDC contains an independently controlled gain stage. The gain is selectable as either 0 dB or 6 dB. When mixing a real input signal down to baseband, it is recommended that the user enable the 6 dB of gain to recenter the dynamic range of the signal within the full scale of the output bits.

When mixing a complex input signal down to baseband, the mixer has already recentered the dynamic range of the signal within the full scale of the output bits, and no additional gain is necessary. However, the optional 6 dB gain compensates for low signal strengths. The downsample by 2 portion of the HB1 FIR filter is bypassed when using the complex to real conversion stage. The TB1 filter does not have the 6 dB gain stage.

**DDC COMPLEX TO REAL CONVERSION**

Each DDC contains an independently controlled complex to real conversion block. The complex to real conversion block reuses the last filter (HB1 FIR) in the filtering stage along with an  $f_s/4$  complex mixer to upconvert the signal. After upconverting the signal, the Q portion of the complex mixer is no longer needed and is dropped. The TB1 filter does not support complex to real conversion.

Figure 101 shows a simplified block diagram of the complex to real conversion.

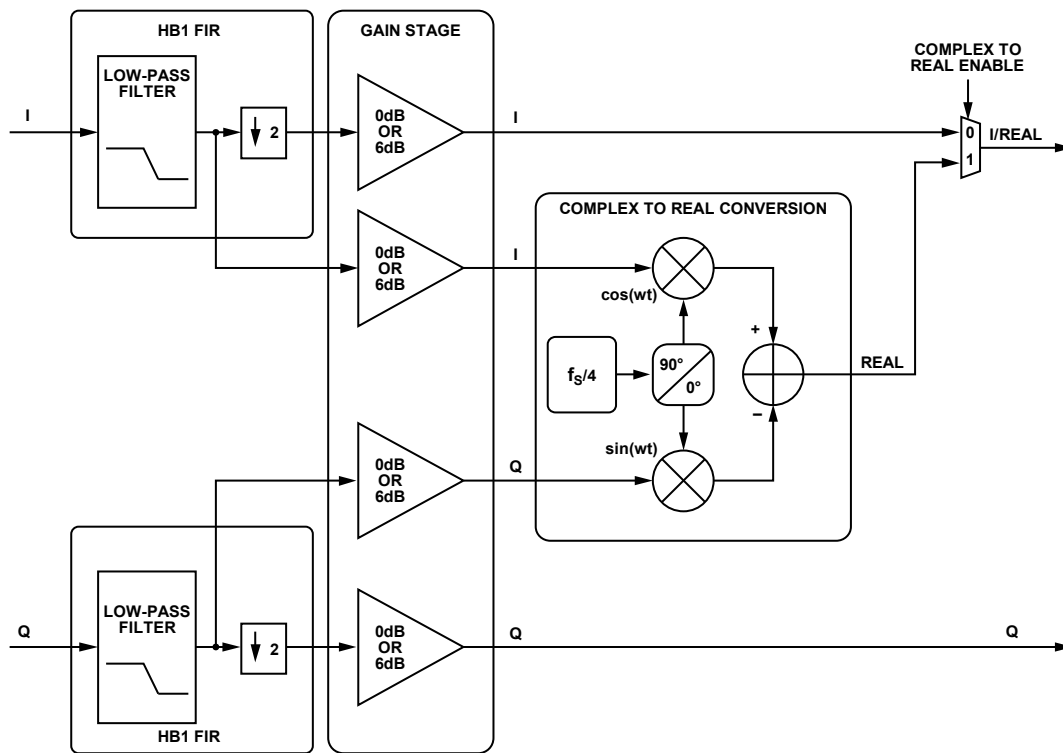

Figure 101. Complex to Real Conversion Block

16547-996

**DDC MIXED DECIMATION SETTINGS**

The AD9208 also supports DDCs with different decimation rates. In this scenario, the chip decimation ratio must be set to the lowest decimation ratio of all the DDC channels. Samples of higher decimation ratio DDCs are repeated to match the chip decimation ratio sample rate. Only mixed decimation ratios that are integer multiples of 2 are supported. For example, decimate by 1, 2, 4, 8, or 16 can be mixed together; decimate by 3, 6, 12, 24, or 48 can be mixed together; or decimate by 5, 10, 20, or 40 can be mixed together.

Table 26 shows the DDC sample mapping when the chip decimation ratio is different than the DDC decimation ratio.

For example, if the chip decimation ratio is set to decimate by 4, DDC0 is set to use the HB2 + HB1 filters (complex outputs are decimate by 4) and DDC1 is set to use the HB4 + HB3 + HB2 + HB1 filters (real outputs are decimate by 8), then DDC1 repeats its output data two times for every one DDC0 output. The resulting output samples are shown in Table 27.

**Table 26. Sample Mapping when the Chip Decimation Ratio (DCM) Does Not Match DDC DCM**

| Sample Index | DDC DCM = Chip DCM | DDC DCM = 2 × Chip DCM | DDC DCM = 4 × Chip DCM | DDC DCM = 8 × Chip DCM |
|--------------|--------------------|------------------------|------------------------|------------------------|
| 0            | N                  | N                      | N                      | N                      |
| 1            | N + 1              | N                      | N                      | N                      |
| 2            | N + 2              | N + 1                  | N                      | N                      |
| 3            | N + 3              | N + 1                  | N                      | N                      |
| 4            | N + 4              | N + 2                  | N + 1                  | N                      |
| 5            | N + 5              | N + 2                  | N + 1                  | N                      |
| 6            | N + 6              | N + 3                  | N + 1                  | N                      |
| 7            | N + 7              | N + 3                  | N + 1                  | N                      |
| 8            | N + 8              | N + 4                  | N + 2                  | N + 1                  |
| 9            | N + 9              | N + 4                  | N + 2                  | N + 1                  |
| 10           | N + 10             | N + 5                  | N + 2                  | N + 1                  |
| 11           | N + 11             | N + 5                  | N + 2                  | N + 1                  |
| 12           | N + 12             | N + 6                  | N + 3                  | N + 1                  |
| 13           | N + 13             | N + 6                  | N + 3                  | N + 1                  |
| 14           | N + 14             | N + 7                  | N + 3                  | N + 1                  |
| 15           | N + 15             | N + 7                  | N + 3                  | N + 1                  |
| 16           | N + 16             | N + 8                  | N + 4                  | N + 2                  |
| 17           | N + 17             | N + 8                  | N + 4                  | N + 2                  |
| 18           | N + 18             | N + 9                  | N + 4                  | N + 2                  |
| 19           | N + 19             | N + 9                  | N + 4                  | N + 2                  |
| 20           | N + 20             | N + 10                 | N + 5                  | N + 2                  |
| 21           | N + 21             | N + 10                 | N + 5                  | N + 2                  |
| 22           | N + 22             | N + 11                 | N + 5                  | N + 2                  |
| 23           | N + 23             | N + 11                 | N + 5                  | N + 2                  |
| 24           | N + 24             | N + 12                 | N + 6                  | N + 3                  |
| 25           | N + 25             | N + 12                 | N + 6                  | N + 3                  |
| 26           | N + 26             | N + 13                 | N + 6                  | N + 3                  |
| 27           | N + 27             | N + 13                 | N + 6                  | N + 3                  |
| 28           | N + 28             | N + 14                 | N + 7                  | N + 3                  |
| 29           | N + 29             | N + 14                 | N + 7                  | N + 3                  |
| 30           | N + 30             | N + 15                 | N + 7                  | N + 3                  |
| 31           | N + 31             | N + 15                 | N + 7                  | N + 3                  |

Table 27. Chip DCM = 4, DDC0 DCM = 4 (Complex), and DDC1 DCM = 8 (Real)<sup>1</sup>

| DDC Input Samples | DDC0          |               | DDC1          |                |
|-------------------|---------------|---------------|---------------|----------------|
|                   | Output Port I | Output Port Q | Output Port I | Output Port Q  |
| N                 | IO[N]         | QO[N]         | I1[N]         | Not applicable |
| N + 1             | IO[N]         | QO[N]         | I1[N]         | Not applicable |
| N + 2             | IO[N]         | QO[N]         | I1[N]         | Not applicable |
| N + 3             | IO[N]         | QO[N]         | I1[N]         | Not applicable |
| N + 4             | IO[N + 1]     | QO[N + 1]     | I1[N]         | Not applicable |
| N + 5             | IO[N + 1]     | QO[N + 1]     | I1[N]         | Not applicable |
| N + 6             | IO[N + 1]     | QO[N + 1]     | I1[N]         | Not applicable |
| N + 7             | IO[N + 1]     | QO[N + 1]     | I1[N]         | Not applicable |
| N + 8             | IO[N + 2]     | QO[N + 2]     | I1[N + 1]     | Not applicable |
| N + 9             | IO[N + 2]     | QO[N + 2]     | I1[N + 1]     | Not applicable |
| N + 10            | IO[N + 2]     | QO[N + 2]     | I1[N + 1]     | Not applicable |
| N + 11            | IO[N + 2]     | QO[N + 2]     | I1[N + 1]     | Not applicable |
| N + 12            | IO[N + 3]     | QO[N + 3]     | I1[N + 1]     | Not applicable |
| N + 13            | IO[N + 3]     | QO[N + 3]     | I1[N + 1]     | Not applicable |
| N + 14            | IO[N + 3]     | QO[N + 3]     | I1[N + 1]     | Not applicable |
| N + 15            | IO[N + 3]     | QO[N + 3]     | I1[N + 1]     | Not applicable |

<sup>1</sup> DCM means decimation.

## DDC EXAMPLE CONFIGURATIONS

Table 28 describes the register settings for multiple DDC example configurations.

Table 28. DDC Example Configurations (Per ADC Channel Pair)

| Chip Application Layer | Chip Decimation Ratio | DDC Input Type | DDC Output Type | Bandwidth Per DDC <sup>1</sup> | No. of Virtual Converters Required | Register Settings   |
|------------------------|-----------------------|----------------|-----------------|--------------------------------|------------------------------------|---|
| One DDC                | 2                     | Complex        | Complex         | $40\% \times f_s$              | 2                                  | 0x0200 = 0x01 (one DDC; I/Q selected)<br>0x0201 = 0x01 (chip decimate by 2)<br>0x0310 = 0x83 (complex mixer; 0 dB gain; variable IF; complex outputs; HB1 filter)<br>0x0311 = 0x04 (DDC I Input = ADC Channel A; DDC Q input = ADC Channel B)<br>0x0316, 0x0317, 0x0318, 0x0319, 0x031A, 0x031B, 0x031D, 0x031E, 0x031F, 0x0320, 0x0321, 0x0322 = FTW and POW set as required by application for DDC0   |
| Two DDCs               | 4                     | Complex        | Complex         | $20\% \times f_s$              | 4                                  | 0x0200 = 0x02 (two DDCs; I/Q selected)<br>0x0201 = 0x02 (chip decimate by 4)<br>0x0310, 0x0330 = 0x80 (complex mixer; 0 dB gain; variable IF; complex outputs; HB2+HB1 filters)<br>0x0311, 0x0331 = 0x04 (DDC I input = ADC Channel A; DDC Q input = ADC Channel B)<br>0x0316, 0x0317, 0x0318, 0x0319, 0x031A, 0x031B, 0x031D, 0x031E, 0x031F, 0x0320, 0x0321, 0x0322 = FTW and POW set as required by application for DDC0<br>0x0336, 0x0337, 0x0338, 0x0339, 0x033A, 0x033B, 0x033D, 0x033E, 0x033F, 0x0340, 0x0341, 0x0342 = FTW and POW set as required by application for DDC1 |

| Chip Application Layer | Chip Decimation Ratio | DDC Input Type | DDC Output Type | Bandwidth Per DDC <sup>1</sup> | No. of Virtual Converters Required | Register Settings  |
|------------------------|-----------------------|----------------|-----------------|--------------------------------|------------------------------------|--|
| Two DDCs               | 4                     | Complex        | Real            | $10\% \times f_s$              | 2                                  | <p>0x0200 = 0x22 (two DDCs; I only selected)<br/>           0x0201 = 0x02 (chip decimate by 4)<br/>           0x0310, 0x0330 = 0x89 (complex mixer; 0 dB gain; variable IF; real output; HB3 + HB2 + HB1 filters)<br/>           0x0311, 0x0331 = 0x04 (DDC I Input = ADC Channel A; DDC Q input = ADC Channel B)<br/>           0x0316, 0x0317, 0x0318, 0x0319, 0x031A, 0x031B, 0x031D, 0x031E, 0x031F, 0x0320, 0x0321, 0x0322 = FTW and POW set as required by application for DDC0<br/>           0x0336, 0x0337, 0x0338, 0x0339, 0x033A, 0x033B, 0x033D, 0x033E, 0x033F, 0x0340, 0x0341, 0x0342 = FTW and POW set as required by application for DDC1</p>  |
| Two DDCs               | 4                     | Real           | Real            | $10\% \times f_s$              | 2                                  | <p>0x0200 = 0x22 (two DDCs; I only selected)<br/>           0x0201 = 0x02 (chip decimate by 4)<br/>           0x0310, 0x0330 = 0x49 (real mixer; 6 dB gain; variable IF; real output; HB3 + HB2 + HB1 filters)<br/>           0x0311 = 0x00 (DDC0 I input = ADC Channel A; DDC0 Q input = ADC Channel A)<br/>           0x0331 = 0x05 (DDC1 I input = ADC Channel B; DDC1 Q input = ADC Channel B)<br/>           0x0316, 0x0317, 0x0318, 0x0319, 0x031A, 0x031B, 0x031D, 0x031E, 0x031F, 0x0320, 0x0321, 0x0322 = FTW and POW set as required by application for DDC0<br/>           0x0336, 0x0337, 0x0338, 0x0339, 0x033A, 0x033B, 0x033D, 0x033E, 0x033F, 0x0340, 0x0341, 0x0342 = FTW and POW set as required by application for DDC1</p>       |
| Two DDCs               | 4                     | Real           | Complex         | $20\% \times f_s$              | 4                                  | <p>0x0200 = 0x02 (two DDCs; I/Q selected)<br/>           0x0201 = 0x02 (chip decimate by 4)<br/>           0x0310, 0x0330 = 0x40 (real mixer; 6 dB gain; variable IF; complex output; HB2 + HB1 filters)<br/>           0x0311 = 0x00 (DDC0 I input = ADC Channel A; DDC0 Q input = ADC Channel A)<br/>           0x0331 = 0x05 (DDC1 I input = ADC Channel B; DDC1 Q input = ADC Channel B)<br/>           0x0316, 0x0317, 0x0318, 0x0319, 0x031A, 0x031B, 0x031D, 0x031E, 0x031F, 0x0320, 0x0321, 0x0322 = FTW and POW set as required by application for DDC0<br/>           0x0336, 0x0337, 0x0338, 0x0339, 0x033A, 0x033B, 0x033D, 0x033E, 0x033F, 0x0340, 0x0341, 0x0342 = FTW and POW set as required by application for DDC1</p>             |
| Two DDCs               | 8                     | Real           | Real            | $5\% \times f_s$               | 2                                  | <p>0x0200 = 0x22 (two DDCs; I only selected)<br/>           0x0201 = 0x03 (chip decimate by 8)<br/>           0x0310, 0x0330 = 0x4A (real mixer; 6 dB gain; variable IF; real output; HB4 + HB3 + HB2 + HB1 filters)<br/>           0x0311 = 0x00 (DDC0 I input = ADC Channel A; DDC0 Q input = ADC Channel A)<br/>           0x0331 = 0x05 (DDC1 I input = ADC Channel B; DDC1 Q input = ADC Channel B)<br/>           0x0316, 0x0317, 0x0318, 0x0319, 0x031A, 0x031B, 0x031D, 0x031E, 0x031F, 0x0320, 0x0321, 0x0322 = FTW and POW set as required by application for DDC0<br/>           0x0336, 0x0337, 0x0338, 0x0339, 0x033A, 0x033B, 0x033D, 0x033E, 0x033F, 0x0340, 0x0341, 0x0342 = FTW and POW set as required by application for DDC1</p> |

| Chip Application Layer | Chip Decimation Ratio | DDC Input Type | DDC Output Type | Bandwidth Per DDC <sup>1</sup> | No. of Virtual Converters Required | Register Settings   |
|------------------------|-----------------------|----------------|-----------------|--------------------------------|------------------------------------|---|
| Four DDCs              | 8                     | Real           | Complex         | $10\% \times f_s$              | 8                                  | <p>0x0200 = 0x03 (four DDCs; I/Q selected)<br/> 0x0201 = 0x03 (chip decimate by 8)<br/> 0x0310, 0x0330, 0x0350, 0x0370 = 0x41 (real mixer; 6 dB gain; variable IF; complex output; HB3 + HB2 + HB1 filters)<br/> 0x0311 = 0x00 (DDC0 I input = ADC Channel A; DDC0 Q input = ADC Channel A)<br/> 0x0331 = 0x00 (DDC1 I input = ADC Channel A; DDC1 Q input = ADC Channel A)<br/> 0x0351 = 0x05 (DDC2 I input = ADC Channel B; DDC2 Q input = ADC Channel B)<br/> 0x0371 = 0x05 (DDC3 I input = ADC Channel B; DDC3 Q input = ADC Channel B)<br/> 0x0316, 0x0317, 0x0318, 0x0319, 0x031A, 0x031B, 0x031D, 0x031E, 0x031F, 0x0320, 0x0321, 0x0322 = FTW and POW set as required by application for DDC0<br/> 0x0336, 0x0337, 0x0338, 0x0339, 0x033A, 0x033B, 0x033D, 0x033E, 0x033F, 0x0340, 0x0341, 0x0342 = FTW and POW set as required by application for DDC1<br/> 0x0356, 0x0357, 0x0358, 0x0359, 0x035A, 0x035B, 0x035D, 0x035E, 0x035F, 0x0360, 0x0361, 0x0362 = FTW and POW set as required by application for DDC2<br/> 0x0376, 0x0377, 0x0378, 0x0379, 0x037A, 0x037B, 0x037D, 0x037E, 0x037F, 0x0380, 0x0381, 0x0382 = FTW and POW set as required by application for DDC3</p>       |
| Four DDCs              | 8                     | Real           | Real            | $5\% \times f_s$               | 4                                  | <p>0x0200 = 0x23 (four DDCs; I only selected)<br/> 0x0201 = 0x03 (chip decimate by 8)<br/> 0x0310, 0x0330, 0x0350, 0x0370 = 0x4A (real mixer; 6 dB gain; variable IF; real output; HB4 + HB3 + HB2 + HB1 filters)<br/> 0x0311 = 0x00 (DDC0 I input = ADC Channel A; DDC0 Q input = ADC Channel A)<br/> 0x0331 = 0x00 (DDC1 I input = ADC Channel A; DDC1 Q input = ADC Channel A)<br/> 0x0351 = 0x05 (DDC2 I input = ADC Channel B; DDC2 Q input = ADC Channel B)<br/> 0x0371 = 0x05 (DDC3 I input = ADC Channel B; DDC3 Q input = ADC Channel B)<br/> 0x0316, 0x0317, 0x0318, 0x0319, 0x031A, 0x031B, 0x031D, 0x031E, 0x031F, 0x0320, 0x0321, 0x0322 = FTW and POW set as required by application for DDC0<br/> 0x0336, 0x0337, 0x0338, 0x0339, 0x033A, 0x033B, 0x033D, 0x033E, 0x033F, 0x0340, 0x0341, 0x0342 = FTW and POW set as required by application for DDC1<br/> 0x0356, 0x0357, 0x0358, 0x0359, 0x035A, 0x035B, 0x035D, 0x035E, 0x035F, 0x0360, 0x0361, 0x0362 = FTW and POW set as required by application for DDC2<br/> 0x0376, 0x0377, 0x0378, 0x0379, 0x037A, 0x037B, 0x037D, 0x037E, 0x037F, 0x0380, 0x0381, 0x0382 = FTW and POW set as required by application for DDC3</p> |

| Chip Application Layer | Chip Decimation Ratio | DDC Input Type | DDC Output Type | Bandwidth Per DDC <sup>1</sup> | No. of Virtual Converters Required | Register Settings  |
|------------------------|-----------------------|----------------|-----------------|--------------------------------|------------------------------------|--|
| Four DDCs              | 16                    | Real           | Complex         | $5\% \times f_s$               | 8                                  | <p>0x0200 = 0x03 (four DDCs; I/Q selected)</p> <p>0x0201 = 0x04 (chip decimate by 16)</p> <p>0x0310, 0x0330, 0x0350, 0x0370 = 0x42 (real mixer; 6 dB gain; variable IF; complex output; HB4 + HB3 + HB2 + HB1 filters)</p> <p>0x0311 = 0x00 (DDC0 I input = ADC Channel A; DDC0 Q input = ADC Channel A)</p> <p>0x0331 = 0x00 (DDC1 I input = ADC Channel A; DDC1 Q input = ADC Channel A)</p> <p>0x0351 = 0x05 (DDC2 I input = ADC Channel B; DDC2 Q input = ADC Channel B)</p> <p>0x0371 = 0x05 (DDC3 I input = ADC Channel B; DDC3 Q input = ADC Channel B)</p> <p>0x0316, 0x0317, 0x0318, 0x0319, 0x031A, 0x031B, 0x031D, 0x031E, 0x031F, 0x0320, 0x0321, 0x0322 = FTW and POW set as required by application for DDC0</p> <p>0x0336, 0x0337, 0x0338, 0x0339, 0x033A, 0x033B, 0x033D, 0x033E, 0x033F, 0x0340, 0x0341, 0x0342 = FTW and POW set as required by application for DDC1</p> <p>0x0356, 0x0357, 0x0358, 0x0359, 0x035A, 0x035B, 0x035D, 0x035E, 0x035F, 0x0360, 0x0361, 0x0362 = FTW and POW set as required by application for DDC2</p> <p>0x0376, 0x0377, 0x0378, 0x0379, 0x037A, 0x037B, 0x037D, 0x037E, 0x037F, 0x0380, 0x0381, 0x0382 = FTW and POW set as required by application for DDC3</p> |

<sup>1</sup>  $f_s$  is the ADC sample rate.

**DDC POWER CONSUMPTION**

Table 29 describes the typical and maximum DVDD and DRVDD1 power for certain DDC modes;  $f_s = 3$  GHz in all cases.

**Table 29. DDC Power Consumption for Example Configurations**

| Number of DDCs | DDC Decimation Ratio <sup>1</sup> | Number of Lanes (L) | Number of Virtual Converters (M) | Number of Octets per frame (F) | DVDD Power (mW) |      | DRVDD1 Power (mW) |     |
|----------------|-----------------------------------|---------------------|----------------------------------|--------------------------------|-----------------|------|-------------------|-----|
|                |                                   |                     |                                  |                                | Typ             | Max  | Typ               | Max |
| 2              | 2                                 | 8                   | 4                                | 1                              | 615             | 1190 | 415               | 565 |
| 2              | 3                                 | 8                   | 4                                | 1                              | 675             | 1250 | 310               | 435 |
| 2              | 4                                 | 8                   | 4                                | 1                              | 585             | 1150 | 250               | 370 |
| 2              | 6                                 | 4                   | 4                                | 2                              | 590             | 1145 | 175               | 275 |
| 2              | 8                                 | 4                   | 4                                | 2                              | 570             | 1120 | 145               | 245 |
| 2              | 12                                | 2                   | 4                                | 4                              | 585             | 1135 | 105               | 205 |
| 4              | 4                                 | 8                   | 8                                | 2                              | 745             | 1350 | 415               | 570 |
| 4              | 6                                 | 8                   | 8                                | 2                              | 755             | 1365 | 305               | 440 |
| 4              | 8                                 | 8                   | 8                                | 2                              | 715             | 1320 | 250               | 370 |

<sup>1</sup> See Table 17 and Table 18 for details on decimation filter selection, the associated alias protected bandwidths, and SNR improvements.

## SIGNAL MONITOR

The signal monitor block provides additional information about the signal being digitized by the ADC. The signal monitor computes the peak magnitude of the digitized signal. This information can be used to drive an AGC loop to optimize the range of the ADC in the presence of real-world signals.

The results of the signal monitor block can be obtained either by reading back the internal values from the SPI port or by embedding the signal monitoring information into the JESD204B interface as separate control bits. A global, 24-bit programmable period controls the duration of the measurement. Figure 102 shows the simplified block diagram of the signal monitor block.

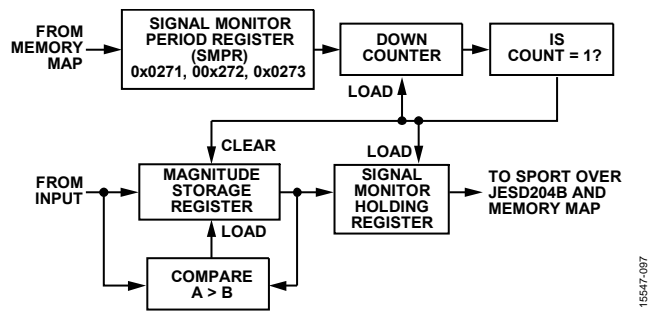

Figure 102. Signal Monitor Block

The peak detector captures the largest signal within the observation period. The detector only observes the magnitude of the signal. The resolution of the peak detector is a 13-bit value, and the observation period is 24 bits and represents converter output samples. The peak magnitude can be derived by using the following equation:

$$\text{Peak Magnitude (dBFS)} = 20\log(\text{Peak Detector Value}/2^{13})$$

The magnitude of the input port signal is monitored over a programmable time period, which is determined by the signal monitor period register (SMPR). The peak detector function is enabled by setting Bit 1 in the signal monitor control register (Register 0x0270). The 24-bit SMPR must be programmed before activating this mode.

After enabling peak detection mode, the value in the SMPR is loaded into a monitor period timer, which decrements at the decimated clock rate. The magnitude of the input signal is compared with the value in the internal magnitude storage register (not accessible to the user), and the greater of the two is updated as the current peak level. The initial value of the magnitude storage register is set to the current ADC input signal magnitude. This comparison continues until the monitor period timer reaches a count of 1.

When the monitor period timer reaches a count of 1, the 13-bit peak level value is transferred to the signal monitor holding register, which can be read through the memory map or output through the SPORT over the JESD204B interface. The monitor period timer is reloaded with the value in the SMPR, and the countdown restarts. In addition, the magnitude of the first input sample is updated in the magnitude storage register, and the comparison and update procedure, as explained previously, continues.



**SPORT OVER JESD204B**

The signal monitor data can also be serialized and sent over the JESD204B interface as control bits. These control bits must be deserialized from the samples to reconstruct the statistical data. The signal control monitor function is enabled by setting Bits[1:0] of Register 0x0279 and Bit 1 of Register 0x027A. Figure 103 shows two different example configurations for the signal monitor control bit locations inside the JESD204B samples. A maximum of three control bits can be inserted into the JESD204B samples; however, only one control bit is required for the signal monitor. Control bits are inserted from MSB to LSB. If only one control bit

is to be inserted (CS = 1), only the most significant control bit is used (see Example Configuration 1 and Example Configuration 2 in Figure 103). To select the SPORT over JESD204B option, program Register 0x0559, Register 0x055A, and Register 0x058F. See Table 46 for more information on setting these bits.

Figure 104 shows the 25-bit frame data that encapsulates the peak detector value. The frame data is transmitted MSB first with five 5-bit subframes. Each subframe contains a start bit that can be used by a receiver to validate the deserialized data. Figure 105 shows the SPORT over JESD204B signal monitor data with a monitor period timer set to 80 samples.

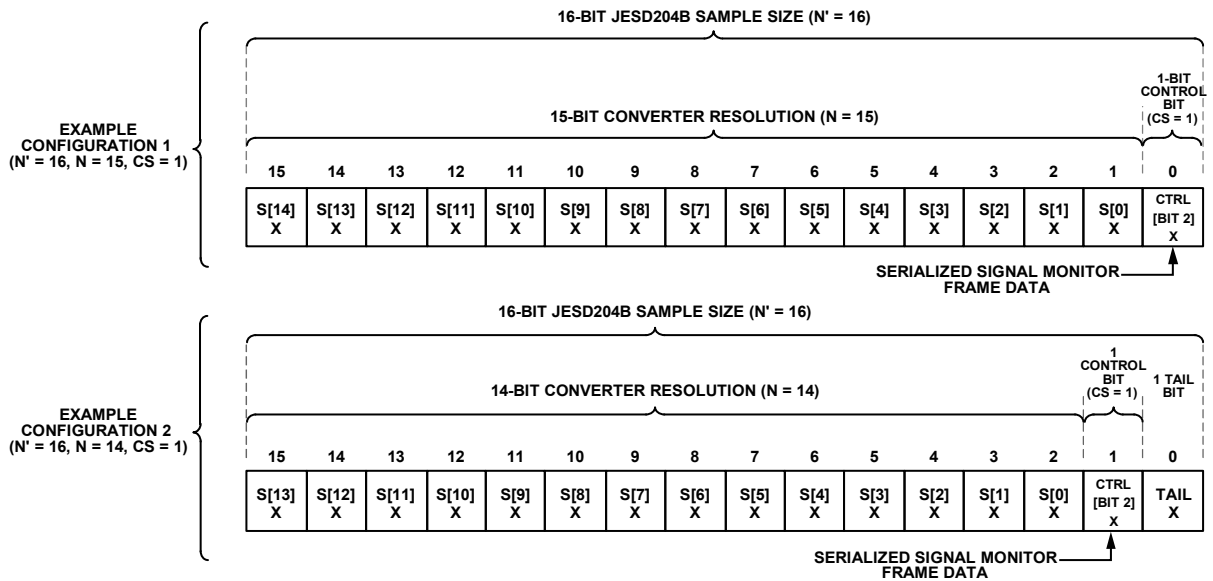

Figure 103. Signal Monitor Control Bit Locations

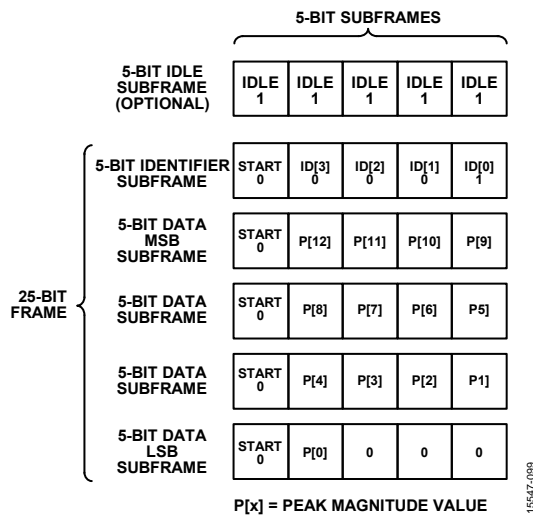
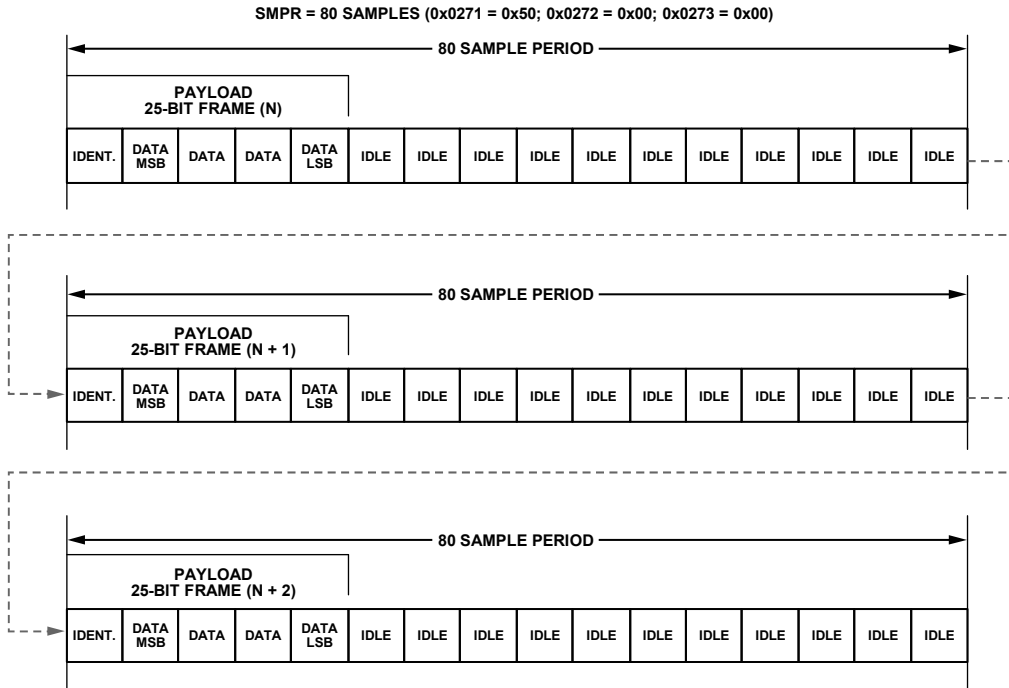

Figure 104. SPORT over JESD204B Signal Monitor Frame Data



15547-100

Figure 105. SPORT over JESD204B Signal Monitor Example with Period = 80 Samples

## DIGITAL OUTPUTS

### INTRODUCTION TO THE JESD204B INTERFACE

The AD9208 digital outputs are designed to the JEDEC standard JESD204B, serial interface for data converters. JESD204B is a protocol to link the AD9208 to a digital processing device over a serial interface with lane rates of up to 16 Gbps. The benefits of the JESD204B interface over LVDS include a reduction in required board area for data interface routing and an ability to enable smaller packages for converter and logic devices.

### JESD204B OVERVIEW

The JESD204B data transmit block assembles the parallel data from the ADC into frames and uses 8-bit/10-bit encoding as well as optional scrambling to form serial output data. Lane synchronization is supported through the use of separate control characters during the initial establishment of the link. Additional control characters are embedded in the data stream to maintain synchronization thereafter. A JESD204B receiver is required to complete the serial link. For additional details on the JESD204B interface, refer to the JESD204B standard.

The AD9208 JESD204B data transmit block maps up to two physical ADCs or up to eight virtual converters (when DDCs are enabled) over a link. A link can be configured to use one, two, four, or eight JESD204B lanes. The JESD204B specification refers to a number of parameters to define the link, and these parameters must match between the JESD204B transmitter (the AD9208 output) and the JESD204B receiver (the logic device input).

The JESD204B link is described according to the following parameters:

- L is the number of lanes per converter device (lanes per link); AD9208 value = 1, 2, 4, or 8.
- M is the number of converters per converter device (virtual converters per link); AD9208 value = 1, 2, 4, or 8.
- F is the octets per frame; AD9208 value = 1, 2, 4, 8, or 16.
- N' is the number of bits per sample (JESD204B word size); AD9208 value = 8 or 16.
- N is the converter resolution; AD9208 value = 7 to 16.
- CS is the number of control bits per sample; AD9208 value = 0, 1, 2, or 3.

- K is the number of frames per multiframe; AD9208 value = 4, 8, 12, 16, 20, 24, 28, or 32.
- S is the samples transmitted per single converter per frame cycle; AD9208 value is set automatically based on L, M, F, and N'.
- HD is the high density mode; the AD9208 mode is set automatically based on L, M, F, and N'.
- CF is the number of control words per frame clock cycle per converter device; AD9208 value = 0.

Figure 106 shows a simplified block diagram of the AD9208 JESD204B link. By default, the AD9208 is configured to use two converters and four lanes. Converter A data is output to SERDOUT0± and/or SERDOUT1±, and Converter B is output to SERDOUT2± and/or SERDOUT3±. The AD9208 allows other configurations such as combining the outputs of both converters onto a single lane, or changing the mapping of the A and B digital output paths. These modes are set up via a quick configuration register in the SPI register map, along with additional customizable options.

By default in the AD9208, the 14-bit converter word from each converter is broken into two octets (eight bits of data). Bit 13 (MSB) through Bit 6 are in the first octet. The second octet contains Bit 5 through Bit 0 (LSB) and two tail bits. The tail bits can be configured as zeros or as a pseudorandom number sequence. The tail bits can also be replaced with control bits indicating overrange, SYSREF±, or fast detect output.

The two resulting octets can be scrambled. Scrambling is optional; however, it is recommended to avoid spectral peaks when transmitting similar digital data patterns. The scrambler uses a self synchronizing, polynomial-based algorithm defined by the equation  $1 + x^{14} + x^{15}$ . The descrambler in the receiver is a self synchronizing version of the scrambler polynomial.

The two octets are then encoded with an 8-bit/10-bit encoder. The 8-bit/10-bit encoder works by taking eight bits of data (an octet) and encoding them into a 10-bit symbol. Figure 107 shows how the 14-bit data is taken from the ADC, how the tail bits are added, how the two octets are scrambled, and how the octets are encoded into two 10-bit symbols. Figure 107 shows the default data format.

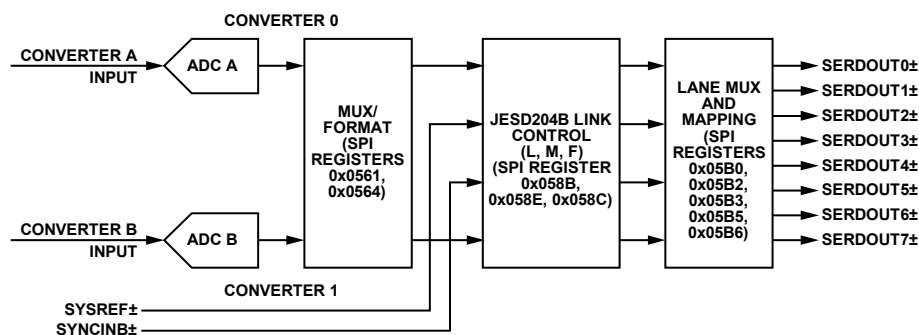

Figure 106. Transmit Link Simplified Block Diagram Showing Full Bandwidth Mode (Register 0x0200 = 0x00)

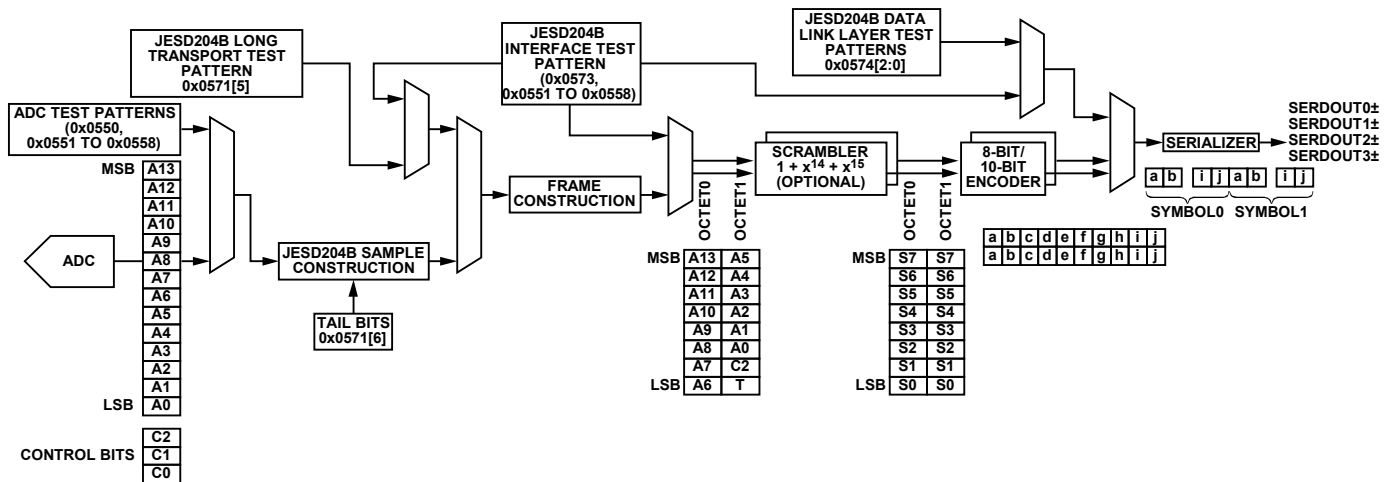

Figure 107. ADC Output Datapath Showing Data Framing

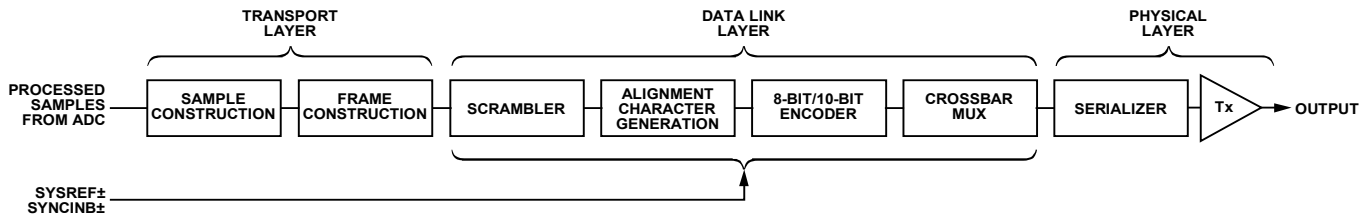

Figure 108. Data Flow

**FUNCTIONAL OVERVIEW**

The block diagram in Figure 108 shows the flow of data through the JESD204B hardware from the sample input to the physical output. The processing can be divided into layers that are derived from the open source initiative (OSI) model widely used to describe the abstraction layers of communications systems. These layers are the transport layer, data link layer, and physical layer (serializer and output driver).

**Transport Layer**

The transport layer handles packing the data (consisting of samples and optional control bits) into JESD204B frames that are mapped to 8-bit octets. These octets are sent to the data link layer. The transport layer mapping is controlled by rules derived from the link parameters. Tail bits are added to fill gaps where required. The following equation can be used to determine the number of tail bits within a sample (JESD204B word):

$$T = N' - N - CS$$

**Data Link Layer**

The data link layer is responsible for the low level functions of passing data across the link. These functions include optionally scrambling the data, inserting control characters for multichip synchronization/lane alignment/monitoring, and encoding 8-bit octets into 10-bit symbols. The data link layer is also responsible for sending the initial lane alignment sequence (ILAS), which contains the link configuration data used by the receiver to verify the settings in the transport layer.

**Physical Layer**

The physical layer consists of the high speed circuitry clocked at the serial clock rate. In this layer, parallel data is converted into one, two, or four lanes of high speed differential serial data.

**JESD204B LINK ESTABLISHMENT**

The AD9208 JESD204B transmitter (Tx) interface operates in Subclass 1 as defined in the JEDEC Standard 204B (July 2011 specification). The link establishment process is divided into the following steps: code group synchronization and SYNCINB±, initial lane alignment sequence, and user data and error correction.

**Code Group Synchronization (CGS) and SYNCINB±**

The CGS is the process by which the JESD204B receiver finds the boundaries between the 10-bit symbols in the stream of data. During the CGS phase, the JESD204B transmit block transmits /K28.5/ characters. The receiver must locate /K28.5/ characters in its input data stream using clock and data recovery (CDR) techniques.

The receiver issues a synchronization request by asserting the SYNCINB± pin of the AD9208 low. The JESD204B Tx then begins sending /K/ characters. After the receiver synchronizes, it waits for the correct reception of at least four consecutive /K/ symbols. It then deasserts SYNCINB±. The AD9208 then transmits an ILAS on the following LMFC boundary.

For more information on the code group synchronization phase, refer to the JEDEC Standard JESD204B, July 2011, Section 5.3.3.1.

The SYNCINB± pin operation can also be controlled by the SPI. The SYNCINB± signal is a differential dc-coupled LVDS mode signal by default, but it can also be driven single-ended. For more information on configuring the SYNCINB± pin operation, refer to Register 0x0572.

The SYNCINB± pins can also be configured to run in CMOS (single-ended) mode, by setting Bit 4 in Register 0x0572. When running SYNCINB± in CMOS mode, connect the CMOS SYNCINB signal to Pin N13 (SYNCINB+) and leave Pin R13 (SYNCINB-) floating.

**Initial Lane Alignment Sequence (ILAS)**

The ILAS phase follows the CGS phase and begins on the next LMFC boundary. The ILAS consists of four multiframe, with an /R/ character marking the beginning and an /A/ character marking the end. The ILAS begins by sending an /R/ character followed by 0 to 255 ramp data for one multiframe. On the second multiframe, the link configuration data is sent, starting with the third character. The second character is a /Q/ character to confirm that the link configuration data is to follow. All undefined data slots are filled with ramp data. The ILAS sequence is never scrambled.

The ILAS sequence construction is shown in Figure 109. The four multiframe include the following:

- Multiframe 1 begins with an /R/ character (/K28.0/) and ends with an /A/ character (/K28.3/).
- Multiframe 2 begins with an /R/ character followed by a /Q/ character (/K28.4/), followed by link configuration parameters over 14 configuration octets (see Table 30) and ends with an /A/ character. Many of the parameter values are of the value - 1 notation.
- Multiframe 3 begins with an /R/ character (/K28.0/) and ends with an /A/ character (/K28.3/).
- Multiframe 4 begins with an /R/ character (/K28.0/) and ends with an /A/ character (/K28.3/).

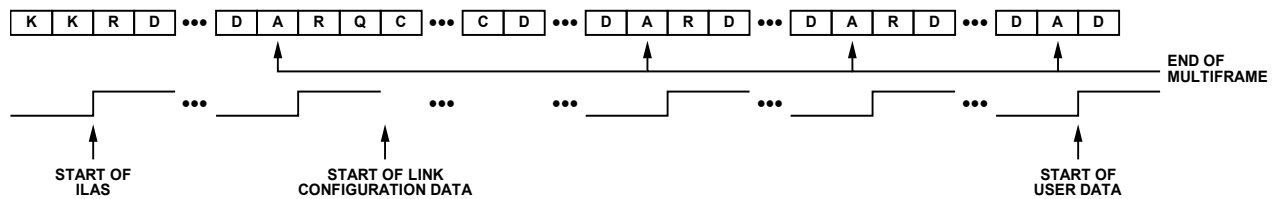

Figure 109. Initial Lane Alignment Sequence

Table 30. AD9208 Control Characters used in JESD204B

| Abbreviation | Control Symbol | 8-Bit Value | 10-Bit Value, RD <sup>1</sup> = -1 | 10-Bit Value, RD <sup>1</sup> = +1 | Description                      |
|--------------|----------------|-------------|------------------------------------|------------------------------------|----------------------------------|
| /R/          | /K28.0/        | 000 11100   | 001111 0100                        | 110000 1011                        | Start of multiframe              |
| /A/          | /K28.3/        | 011 11100   | 001111 0011                        | 110000 1100                        | Lane alignment                   |
| /Q/          | /K28.4/        | 100 11100   | 001111 0100                        | 110000 1101                        | Start of link configuration data |
| /K/          | /K28.5/        | 101 11100   | 001111 1010                        | 110000 0101                        | Group synchronization            |
| /F/          | /K28.7/        | 111 11100   | 001111 1000                        | 110000 0111                        | Frame alignment                  |

<sup>1</sup> RD means running disparity.

**User Data and Error Detection**

After the initial lane alignment sequence is complete, the user data is sent. Normally, within a frame, all characters are considered user data. However, to monitor the frame clock and multiframe clock synchronization, there is a mechanism for replacing characters with /F/ or /A/ alignment characters when the data meets certain conditions. These conditions are different for unscrambled and scrambled data. The scrambling operation is enabled by default; however, it can be disabled using the SPI.

For scrambled data, any 0xFC character at the end of a frame is replaced by an /F/, and any 0x7C character at the end of a multiframe is replaced by an /A/. The JESD204B receiver (Rx) checks for /F/ and /A/ characters in the received data stream and verifies that they only occur in the expected locations. If an unexpected /F/ or /A/ character is found, the receiver handles the situation by using dynamic realignment or asserting the SYNCINB± signal for more than four frames to initiate a resynchronization. For unscrambled data, if the final character of two subsequent frames is equal, the second character is replaced with an /F/ if it is at the end of a frame, and an /A/ if it is at the end of a multiframe.

Insertion of alignment characters can be modified using the SPI. The frame alignment character insertion (FACI) is enabled by default. More information on the link controls is available in the Memory Map section, Register 0x0571.

**8-Bit/10-Bit Encoder**

The 8-bit/10-bit encoder converts 8-bit octets into 10-bit symbols and inserts control characters into the stream when needed. The control characters used in JESD204B are shown in Table 30. The 8-bit/10-bit encoding ensures that the signal is dc balanced by using the same number of ones and zeros across multiple symbols.

The 8-bit/10-bit interface has options that can be controlled via the SPI. These operations include bypass and invert. These options are troubleshooting tools for the verification of the digital front end (DFE). See the Memory Map section, Register 0x0572, Bits[2:1] for information on configuring the 8-bit/10-bit encoder.

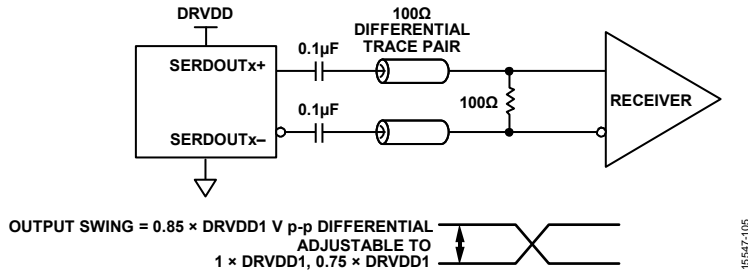

Figure 110. AC-Coupled Digital Output Termination Example

**PHYSICAL LAYER (DRIVER) OUTPUTS**

**Digital Outputs, Timing, and Controls**

The AD9208 physical layer consists of drivers that are defined in the JEDEC Standard JESD204B, July 2011. The differential digital outputs are powered up by default. The drivers use a dynamic 100 Ω internal termination to reduce unwanted reflections.

Place a 100 Ω differential termination resistor at each receiver input to result in a nominal  $0.85 \times \text{DRVDD1}$  V p-p swing at the receiver (see Figure 110). The swing is adjustable through the SPI registers. AC coupling is recommended to connect to the receiver. See the Memory Map section (Register 0x05C0 to Register 0x05C3 in Table 46) for more details.

The AD9208 digital outputs can interface with custom ASICs and field programmable gate array (FPGA) receivers, providing superior switching performance in noisy environments. Single point-to-point network topologies are recommended with a single differential 100 Ω termination resistor placed as close to the receiver inputs as possible.

If there is no far end receiver termination, or if there is poor differential trace routing, timing errors can result. To avoid such timing errors, it is recommended that the trace length be less than six inches, and that the differential output traces be close together and at equal lengths.

Figure 111 to Figure 113 show an example of the digital output data eye, jitter histogram, and bathtub curve for one AD9208 lane running at 16 Gbps. The format of the output data is twos complement by default. To change the output data format, see the Memory Map section (Register 0x0561 in Table 46).

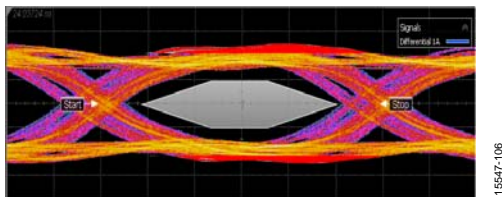

Figure 111. Digital Outputs Data Eye, External 100 Ω Terminations at 16 Gbps

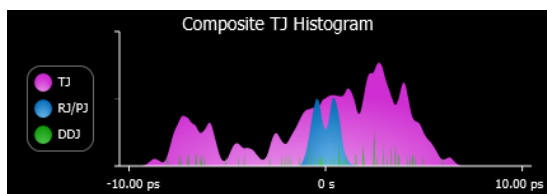

Figure 112. Digital Outputs Jitter Histogram, External 100 Ω Terminations at

16 Gbps

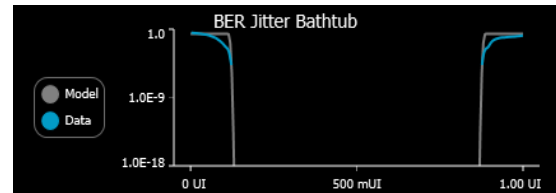

Figure 113. Digital Outputs Bathtub Curve, External 100 Ω Terminations at 16 Gbps

**De-Emphasis**

De-emphasis enables the receiver eye diagram mask to be met in conditions where the interconnect insertion loss does not meet the JESD204B specification. Use the de-emphasis feature only when the receiver is unable to recover the clock due to excessive insertion loss. Under normal conditions, it is disabled to conserve power. Additionally, enabling and setting too high a de-emphasis value on a short link can cause the receiver eye diagram to fail. Use the de-emphasis setting with caution because it can increase electromagnetic interference (EMI). See the Memory Map section (Register 0x05C4 to Register 0x05CB in Table 46) for more details.

**Phase-Locked Loop (PLL)**

The PLL generates the serializer clock, which operates at the JESD204B lane rate. The status of the PLL lock can be checked in the PLL locked status bit (Register 0x056F, Bit 7). This read only bit notifies the user if the PLL achieved a lock for the specific setup. Register 0x056F also has a loss of lock (LOL) sticky bit (Bit 3) that notifies the user that a loss of lock is detected. The sticky bit can be reset by issuing a JESD204B link restart (Register 0x0571 = 0x15, followed by Register 0x0571 = 0x14). Refer to Table 32 for the reinitialization of the link following a link power cycle.

The JESD204B lane rate control, Bits[7:4] of Register 0x056E, must be set to correspond with the lane rate. Table 31 shows the lane rates supported by the AD9208 using Register 0x056E.

**Table 31. AD9208 Register 0x056E Supported Lane Rates**

| Value | Lane Rate   |
|-------|---|
| 0x00  | Lane rate = 6.75 Gbps to 13.5 Gbps                      |
| 0x10  | Lane rate = 3.375 Gbps to 6.75 Gbps                     |
| 0x30  | Lane rate = 13.5 Gbps to 15.5 Gbps (default for AD9208) |
| 0x50  | Lane rate = 1.6875 Gbps to 3.375 Gbps                   |

**$f_s \times 4$  MODE**

$f_s \times 4$  mode adds a separate packing mode on top of a JESD204B transmitter/receiver to fix the serial lane rate at four times the sample rate ( $f_s$ ).

The JESD204B link settings are

- L = 8
- M = 2
- F = 2
- S = 5
- $N' = 12$
- N = 12
- CS = 0
- CF = 2
- HD = 1

However, CF = 2 is not supported by the design; therefore, the following link parameters are used along with separate packing:

- L = 8
- M = 2
- F = 2
- S = 4

- $N' = 16$
- N = 16
- CS = 0
- CF = 0
- HD = 0

In  $f_s \times 4$  mode, five 12-bit ADC samples (along with an extra 4 bits) are packed into four 16-bit JESD204B samples to create a 64-bit frame.

The following SPI writes are necessary to place the device in  $f_s \times 4$  mode:

- Register 0x0570 = 0xFE. This setting places the device in M = 2, L = 8,  $f_s \times 4$  mode.
- Register 0x058B = 0x0F. This setting places the device CS = 0,  $N' = 16$  mode.
- Register 0x058F = 0x2F. This setting places the device in Subclass 1 mode, N = 16.

The transmit architecture of  $f_s \times 4$  mode is shown in Figure 114 and the receive portion is shown in Figure 115.  $f_s \times 4$  mode only works in full bandwidth mode (Register 0x0200 = 0x00).

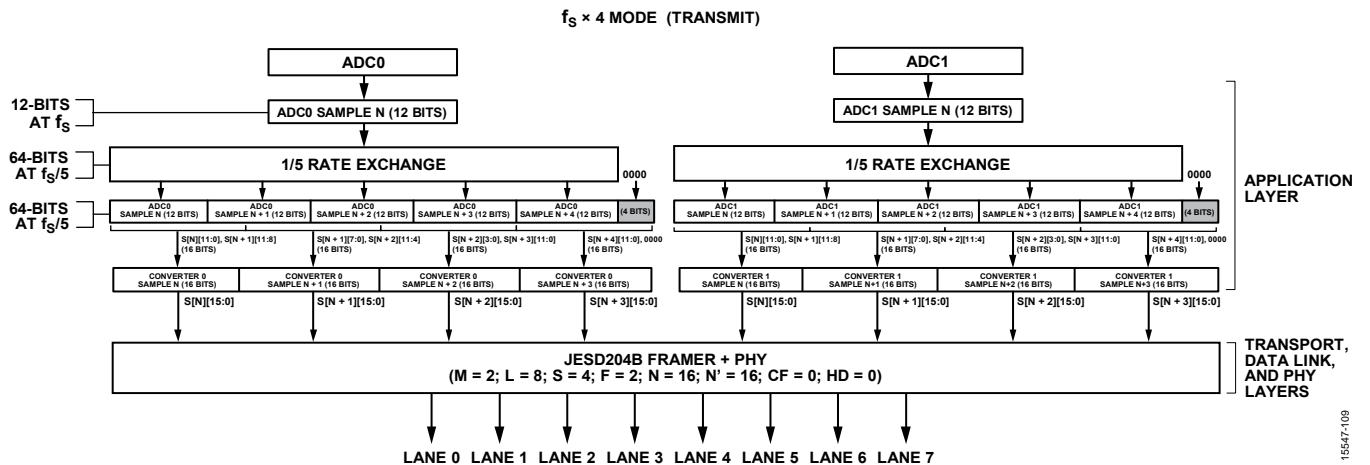

Figure 114.  $f_s \times 4$  Mode (Transmit)

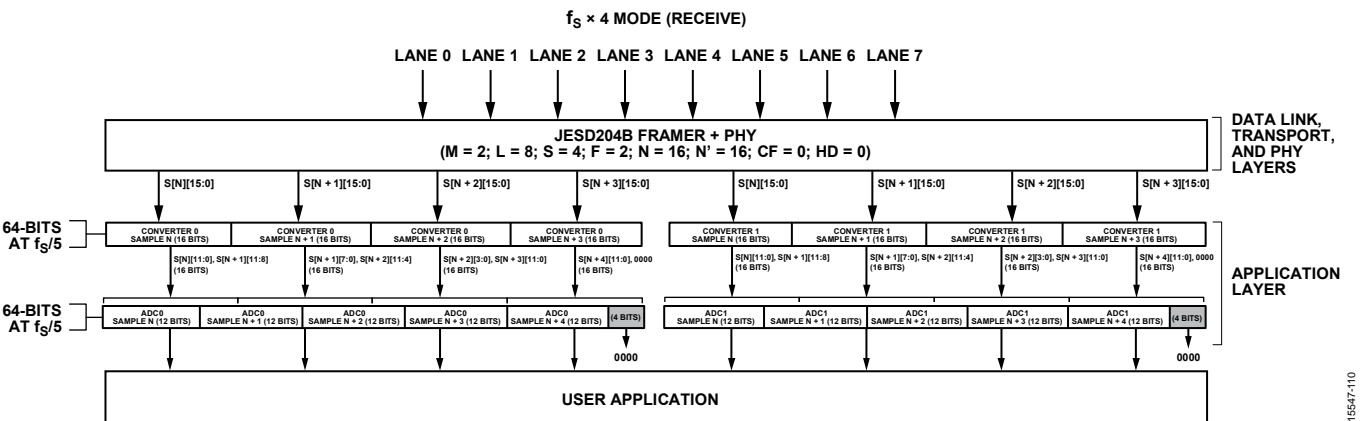

Figure 115.  $f_s \times 4$  Mode (Receive)

## SETTING UP THE AD9208 DIGITAL INTERFACE

To ensure proper operation of the AD9208 at startup, some SPI writes are required to initialize the link. Additionally, these registers must be written every time the ADC is reset. Any one of the following resets warrants the initialization routine for the digital interface:

- Hard reset, as with power-up.
- Power-up using the PDWN pin.
- Power-up using the SPI via Register 0x0002, Bits[1:0].
- SPI soft reset by setting Register 0x0000 = 0x81.
- Datapath soft reset by setting Register 0x0001 = 0x02.
- JESD204B link power cycle by setting Register 0x0571 = 0x15, then 0x14.

The initialization SPI writes are as shown in Table 32.

**Table 32. AD9208 JESD204B Initialization**

| Register | Value | Comment                                       |
|----------|-------|---|
| 0x1228   | 0x4F  | Reset JESD204B start-up circuit               |
| 0x1228   | 0x0F  | JESD204B start-up circuit in normal operation |
| 0x1222   | 0x00  | JESD204B PLL force normal operation           |
| 0x1222   | 0x04  | Reset JESD204B PLL calibration                |
| 0x1222   | 0x00  | JESD204B PLL normal operation                 |
| 0x1262   | 0x08  | Clear loss of lock bit                        |
| 0x1262   | 0x00  | Loss of lock bit normal operation             |

The AD9208 has one JESD204B link. The serial outputs (SERDOUT0± to SERDOUT7±) are considered to be part of one JESD204B link. The basic parameters that determine the link setup are

- Number of lanes per link (L)
- Number of converters per link (M)
- Number of octets per frame (F)

**Table 33. JESD204B Output Configurations for N' = 16<sup>1</sup>**

| Number of Virtual Converters Supported (Same as M) | JESD204B Serial Lane Rate <sup>2</sup> | Supported Decimation Rates       |                                  |                                   |                                    | JESD204B Transport Layer Settings <sup>3</sup> |   |   |   |    |         |    |        |            |
|--|--|----------------------------------|----------------------------------|-----------------------------------|------------------------------------|--|---|---|---|----|---------|----|--------|------------|
|  |  | Lane Rate = 1.7 Gbps to 3.4 Gbps | Lane Rate = 3.4 Gbps to 6.8 Gbps | Lane Rate = 6.8 Gbps to 13.6 Gbps | Lane Rate = 13.6 Gbps to 15.5 Gbps | L  | M | F | S | HD | N       | N' | CS     | K          |
| 1  | 20 × f <sub>OUT</sub>                  | 2, 4, 5, 6, 8, 10, 12, 20, 24    | 1, 2, 3, 4, 5, 6, 8, 10, 12      | 1, 2, 3, 4, 5, 6, 8               | 1, 2, 3, 4                         | 1  | 1 | 2 | 1 | 0  | 8 to 16 | 16 | 0 to 3 | See Note 4 |
|  | 20 × f <sub>OUT</sub>                  | 2, 4, 5, 6, 8, 10, 12, 20, 24    | 1, 2, 3, 4, 5, 6, 8, 10, 12      | 1, 2, 3, 4, 5, 6, 8               | 1, 2, 3, 4                         | 1  | 1 | 4 | 2 | 0  | 8 to 16 | 16 | 0 to 3 | See Note 4 |
|  | 10 × f <sub>OUT</sub>                  | 1, 2, 3, 4, 5, 6, 8, 10, 12      | 1, 2, 3, 4, 5, 6, 8              | 1, 2, 3, 4                        | 1, 2                               | 2  | 1 | 1 | 1 | 1  | 8 to 16 | 16 | 0 to 3 | See Note 4 |
|  | 10 × f <sub>OUT</sub>                  | 1, 2, 3, 4, 5, 6, 8, 10, 12      | 1, 2, 3, 4, 5, 6, 8              | 1, 2, 3, 4                        | 1, 2                               | 2  | 1 | 2 | 2 | 0  | 8 to 16 | 16 | 0 to 3 | See Note 4 |
|  | 5 × f <sub>OUT</sub>                   | 1, 2, 3, 4, 5, 6, 8              | 1, 2, 3, 4                       | 1, 2                              | 1                                  | 4  | 1 | 1 | 2 | 1  | 8 to 16 | 16 | 0 to 3 | See Note 4 |
|  | 5 × f <sub>OUT</sub>                   | 1, 2, 3, 4, 5, 6, 8              | 1, 2, 3, 4                       | 1, 2                              | 1                                  | 4  | 1 | 2 | 4 | 0  | 8 to 16 | 16 | 0 to 3 | See Note 4 |
|  | 2.5 × f <sub>OUT</sub>                 | 1, 2, 3, 4                       | 1, 2                             | 1                                 | 1                                  | 8  | 1 | 1 | 4 | 1  | 8 to 16 | 16 | 0 to 3 | See Note 4 |
|  | 2.5 × f <sub>OUT</sub>                 | 1, 2, 3, 4                       | 1, 2                             | 1                                 | 1                                  | 8  | 1 | 2 | 8 | 0  | 8 to 16 | 16 | 0 to 3 | See Note 4 |

If the internal DDCs are used for on-chip digital processing, M represents the number of virtual converters. The virtual converter mapping setup is shown in Figure 77.

The maximum lane rate allowed by the AD9208 is 16 Gbps. The lane rate is related to the JESD204B parameters using the following equation:

$$\text{Lane Rate} = \frac{M \times N' \times \left(\frac{10}{8}\right) \times f_{OUT}}{L}$$

$$\text{where } f_{OUT} = \frac{f_{ADC\_CLOCK}}{\text{Decimation Ratio}}$$

The decimation ratio (DCM) is the parameter programmed in Register 0x201.

Use the following procedure to configure the output:

1. Power down the link.
2. Select the JESD204B link configuration options.
3. Configure the detailed options.
4. Set output lane mapping (optional).
5. Set additional driver configuration options (optional).
6. Power up the link.
7. Initialize the JESD204B link by issuing the commands described in Table 32.

If the lane rate calculated is less than 6.25 Gbps, select the low lane rate option by programming a value of 0x10 to Register 0x056E.

Table 33 and Table 34 show the JESD204B output configurations supported for both N' = 16 and N' = 8 for a given number of virtual converters. Take care to ensure that the serial lane rate for a given configuration is within the supported range of 3.4 Gbps to 16 Gbps.



| Number of Virtual Converters Supported (Same as M) | JESD204B Serial Lane Rate <sup>2</sup> | Supported Decimation Rates                |   |  |   | JESD204B Transport Layer Settings <sup>3</sup> |                     |    |   |    |         |    |         |            |
|--|--|---|---|--|---|--|---------------------|----|---|----|---------|----|---------|------------|
|  |  | Lane Rate = 1.7 Gbps to 3.4 Gbps          | Lane Rate = 3.4 Gbps to 6.8 Gbps          | Lane Rate = 6.8 Gbps to 13.6 Gbps        | Lane Rate = 13.6 Gbps to 15.5 Gbps        | L  | M                   | F  | S | HD | N       | N' | CS      | K          |
|  |  | 2   | 40 × f <sub>OUT</sub>                     | 4, 8, 10, 12, 15, 16, 20, 24, 30, 40, 48 | 2, 4, 5, 6, 8, 10, 12, 15, 16, 20, 24, 30 | 1, 2, 3, 4, 5, 6, 8, 10, 12, 15, 16            | 1, 2, 3, 4, 5, 6, 8 | 1  | 2 | 4  | 1       | 0  | 8 to 16 | 16         |
|  | 40 × f <sub>OUT</sub>                  | 4, 8, 10, 12, 15, 16, 20, 24, 30, 40, 48  | 2, 4, 5, 6, 8, 10, 12, 15, 16, 20, 24, 30 | 1, 2, 3, 4, 5, 6, 8, 10, 12, 15, 16      | 1, 2, 3, 4, 5, 6, 8                       | 1  | 2                   | 8  | 2 | 0  | 8 to 16 | 16 | 0 to 3  | See Note 4 |
|  | 20 × f <sub>OUT</sub>                  | 2, 4, 5, 6, 8, 10, 12, 15, 16, 20, 24, 30 | 1, 2, 3, 4, 5, 6, 8, 10, 12, 15, 16       | 1, 2, 3, 4, 5, 6, 8                      | 1, 2, 3, 4                                | 2  | 2                   | 2  | 1 | 0  | 8 to 16 | 16 | 0 to 3  | See Note 4 |
|  | 20 × f <sub>OUT</sub>                  | 2, 4, 5, 6, 8, 10, 12, 15, 16, 20, 24, 30 | 1, 2, 3, 4, 5, 6, 8, 10, 12, 15, 16       | 1, 2, 3, 4, 5, 6, 8                      | 1, 2, 3, 4                                | 2  | 2                   | 4  | 2 | 0  | 8 to 16 | 16 | 0 to 3  | See Note 4 |
|  | 10 × f <sub>OUT</sub>                  | 1, 2, 3, 4, 5, 6, 8, 10, 12, 15, 16       | 1, 2, 3, 4, 5, 6, 8                       | 1, 2, 3, 4                               | 1, 2                                      | 4  | 2                   | 1  | 1 | 1  | 8 to 16 | 16 | 0 to 3  | See Note 4 |
|  | 10 × f <sub>OUT</sub>                  | 1, 2, 3, 4, 5, 6, 8, 10, 12, 15, 16       | 1, 2, 3, 4, 5, 6, 8                       | 1, 2, 3, 4                               | 1, 2                                      | 4  | 2                   | 2  | 2 | 0  | 8 to 16 | 16 | 0 to 3  | See Note 4 |
|  | 5 × f <sub>OUT</sub>                   | 1, 2, 3, 4, 5, 6, 8                       | 1, 2, 3, 4                                | 1, 2                                     | 1   | 8  | 2                   | 1  | 2 | 1  | 8 to 16 | 16 | 0 to 3  | See Note 4 |
|  | 5 × f <sub>OUT</sub>                   | 1, 2, 3, 4, 5, 6, 8                       | 1, 2, 3, 4                                | 1, 2                                     | 1   | 8  | 2                   | 2  | 4 | 0  | 8 to 16 | 16 | 0 to 3  | See Note 4 |
| 4  | 80 × f <sub>OUT</sub>                  | 8, 16, 20, 24, 30, 40, 48                 | 4, 8, 10, 12, 16, 20, 24, 30, 40, 48      | 2, 4, 6, 8, 10, 12, 16, 20, 24, 30       | 2, 4, 6, 8, 10, 12, 16                    | 1  | 4                   | 8  | 1 | 0  | 8 to 16 | 16 | 0 to 3  | See Note 4 |
|  | 40 × f <sub>OUT</sub>                  | 4, 8, 10, 12, 15, 16, 20, 24, 30, 40, 48  | 2, 4, 5, 6, 8, 10, 12, 15, 16, 20, 24, 30 | 1, 2, 3, 4, 5, 6, 8, 10, 12, 15, 16      | 1, 2, 3, 4, 5, 6, 8                       | 2  | 4                   | 4  | 1 | 0  | 8 to 16 | 16 | 0 to 3  | See Note 4 |
|  | 40 × f <sub>OUT</sub>                  | 4, 8, 10, 12, 15, 16, 20, 24, 30, 40, 48  | 2, 4, 5, 6, 8, 10, 12, 15, 16, 20, 24, 30 | 1, 2, 3, 4, 5, 6, 8, 10, 12, 15, 16      | 1, 2, 3, 4, 5, 6, 8                       | 2  | 4                   | 8  | 2 | 0  | 8 to 16 | 16 | 0 to 3  | See Note 4 |
|  | 20 × f <sub>OUT</sub>                  | 2, 4, 5, 6, 8, 10, 12, 15, 16, 20, 24, 30 | 1, 2, 3, 4, 5, 6, 8, 10, 12, 15, 16       | 1, 2, 3, 4, 5, 6, 8                      | 1, 2, 3, 4                                | 4  | 4                   | 2  | 1 | 0  | 8 to 16 | 16 | 0 to 3  | See Note 4 |
|  | 20 × f <sub>OUT</sub>                  | 2, 4, 5, 6, 8, 10, 12, 15, 16, 20, 24, 30 | 1, 2, 3, 4, 5, 6, 8, 10, 12, 15, 16       | 1, 2, 3, 4, 5, 6, 8                      | 1, 2, 3, 4                                | 4  | 4                   | 4  | 2 | 0  | 8 to 16 | 16 | 0 to 3  | See Note 4 |
|  | 10 × f <sub>OUT</sub>                  | 1, 2, 3, 4, 5, 6, 8, 10, 12, 15, 16       | 1, 2, 3, 4, 5, 6, 8                       | 1, 2, 3, 4                               | 1, 2                                      | 8  | 4                   | 1  | 1 | 1  | 8 to 16 | 16 | 0 to 3  | See Note 4 |
|  | 10 × f <sub>OUT</sub>                  | 1, 2, 3, 4, 5, 6, 8, 10, 12, 15, 16       | 1, 2, 3, 4, 5, 6, 8                       | 1, 2, 3, 4                               | 1, 2                                      | 8  | 4                   | 2  | 2 | 0  | 8 to 16 | 16 | 0 to 3  | See Note 4 |
| 8  | 160 × f <sub>OUT</sub>                 | 16, 40, 48                                | 8, 16, 20, 24, 40, 48                     | 4, 8, 12, 16, 20, 24, 40, 48             | 4, 8, 12, 16, 20, 24                      | 1  | 8                   | 16 | 1 | 0  | 8 to 16 | 16 | 0 to 3  | See Note 4 |
|  | 80 × f <sub>OUT</sub>                  | 8, 16, 20, 24, 40, 48                     | 4, 8, 10, 12, 16, 20, 24, 40, 48          | 2, 4, 6, 8, 10, 12, 16, 20, 24           | 2, 4, 6, 8, 10, 12, 16                    | 2  | 8                   | 8  | 1 | 0  | 8 to 16 | 16 | 0 to 3  | See Note 4 |
|  | 40 × f <sub>OUT</sub>                  | 4, 8, 10, 12, 16, 20, 24, 40, 48          | 2, 4, 6, 8, 10, 12, 16, 20, 24            | 2, 4, 6, 8, 10, 12, 16                   | 2, 4, 6, 8                                | 4  | 8                   | 4  | 1 | 0  | 8 to 16 | 16 | 0 to 3  | See Note 4 |
|  | 40 × f <sub>OUT</sub>                  | 4, 8, 10, 12, 16, 20, 24, 40, 48          | 2, 4, 6, 8, 10, 12, 16, 20, 24            | 2, 4, 6, 8, 10, 12, 16                   | 2, 4, 6, 8                                | 4  | 8                   | 8  | 2 | 0  | 8 to 16 | 16 | 0 to 3  | See Note 4 |
|  | 20 × f <sub>OUT</sub>                  | 2, 4, 6, 8, 10, 12, 16, 20, 24            | 2, 4, 6, 8, 10, 12, 16                    | 2, 4, 6, 8                               | 2, 4                                      | 8  | 8                   | 2  | 1 | 0  | 8 to 16 | 16 | 0 to 3  | See Note 4 |
|  | 20 × f <sub>OUT</sub>                  | 2, 4, 6, 8, 10, 12, 16, 20, 24            | 2, 4, 6, 8, 10, 12, 16                    | 2, 4, 6, 8                               | 2, 4                                      | 8  | 8                   | 4  | 2 | 0  | 8 to 16 | 16 | 0 to 3  | See Note 4 |

<sup>1</sup> Due to the internal clock requirements, only certain decimation rates are supported for certain link parameters.

<sup>2</sup> JESD204B transport layer descriptions are as follows: L is the number of lanes per converter device (lanes per link); M is the number of virtual converters per converter device (virtual converters per link); F is the octets per frame; S is the samples transmitted per virtual converter per frame cycle; HD is the high density mode; N is the virtual converter resolution (in bits); N' is the total number of bits per sample (JESD204B word size); CS is the number of control bits per conversion sample; K is the number of frames per multiframe.

<sup>3</sup> f<sub>ADC\_CLK</sub> is the ADC sample rate; DCM = chip decimation ratio; f<sub>OUT</sub> is the output sample rate = f<sub>ADC\_CLK</sub>/DCM; SLR is the JESD204B serial lane rate. The following equations must be met due to internal clock divider requirements: SLR ≥ 1.6875 Gbps and SLR ≤ 15.5 Gbps; SLR/40 ≤ f<sub>ADC\_CLK</sub>; least common multiple (20 × DCM × f<sub>OUT</sub>/SLR, DCM) ≤ 64. When the SLR is ≤ 15500 Mbps and > 13500 Mbps, Register 0x056E must be set to 0x30. When the SLR is ≤ 13500 Mbps and ≥ 6750 Mbps, Register 0x056E must be set to 0x00. When the SLR is < 6750 Mbps and ≥ 3375 Mbps, Register 0x056E must be set to 0x10. When the SLR is < 3375 Mbps and ≥ 1687.5 Mbps, Register 0x056E must be set to 0x50.

<sup>4</sup> Only valid K × F values that are divisible by 4 are supported: for F = 1, K = 20, 24, 28, 32; for F = 2, K = 12, 16, 20, 24, 28, 32; for F = 4, K = 8, 12, 16, 20, 24, 28, 32; for F = 8, K = 4, 8, 12, 16, 20, 24, 28, 32; and for F = 16, K = 4, 8, 12, 16, 20, 24, 28, 32.

Table 34. JESD204B Output Configurations (N' = 12)<sup>1</sup>

| No. of Virtual Converters Supported (Same Value as M) | Serial Lane Rate <sup>2</sup> | Supported Decimation Rates for Lane Rate = 1.7 Gbps to 3.4 Gbps | Supported Decimation Rates for Lane Rate = 3.4 Gbps to 6.8 Gbps | Supported Decimation Rates for Lane Rate = 6.8 Gbps to 13.5 Gbps | Supported Decimation Rates for Lane Rate = 13.5 Gbps to 15.5 Gbps | JESD204B Transport Layer Settings <sup>3</sup> |   |   |   |    |         |    |        |            |
|---|-------------------------------|---|---|--|---|--|---|---|---|----|---------|----|--------|------------|
|   |                               |   |   |  |   | L  | M | F | S | HD | N       | N' | L      | K          |
| 1   | 15 × f <sub>OUT</sub>         | 3, 6, 12  | 3, 6, 12  | 3, 6   |   | 1  | 1 | 3 | 2 | 0  | 8 to 12 | 12 | 0 to 3 | See Note 4 |
|   | 7.5 × f <sub>OUT</sub>        | 3, 6  | 3, 6  | 3  |   | 2  | 1 | 3 | 4 | 1  | 8 to 12 | 12 | 0 to 3 | See Note 4 |
|   | 7.5 × f <sub>OUT</sub>        | 3, 6  | 3, 6  | 3  |   | 2  | 1 | 6 | 8 | 0  | 8 to 12 | 12 | 0 to 3 | See Note 4 |
|   | 5 × f <sub>OUT</sub>          | 1, 2, 3, 4, 5, 6, 8   | 1, 2, 3, 4  | 1, 2   | 1   | 3  | 1 | 1 | 2 | 1  | 8 to 12 | 12 | 0 to 3 | See Note 4 |
| 2   | 30 × f <sub>OUT</sub>         | 3, 6, 12, 24  | 3, 6, 12, 24  | 3, 6, 12   |   | 1  | 2 | 3 | 1 | 0  | 8 to 12 | 12 | 0 to 3 | See Note 4 |
|   | 15 × f <sub>OUT</sub>         | 3, 6, 12  | 3, 6, 12  | 3, 6   |   | 2  | 2 | 3 | 2 | 0  | 8 to 12 | 12 | 0 to 3 | See Note 4 |
|   | 10 × f <sub>OUT</sub>         | 1, 2, 3, 4, 5, 6, 8, 10, 12, 16                                 | 1, 2, 3, 4, 5, 6, 8   | 1, 2, 3, 4   | 1, 2  | 3  | 2 | 1 | 1 | 1  | 8 to 12 | 12 | 0 to 3 | See Note 4 |
|   | 7.5 × f <sub>OUT</sub>        | 3, 6  | 3, 6  | 3  |   | 4  | 2 | 3 | 4 | 0  | 8 to 12 | 12 | 0 to 3 | See Note 4 |
| 4   | 60 × f <sub>OUT</sub>         | 6, 12, 24, 48   | 3, 6, 12, 24, 48  | 3, 6, 12, 24   |   | 1  | 4 | 6 | 1 | 0  | 8 to 12 | 12 | 0 to 3 | See Note 4 |
|   | 30 × f <sub>OUT</sub>         | 3, 6, 12, 24  | 3, 6, 12, 24  | 3, 6, 12   |   | 2  | 4 | 3 | 1 | 0  | 8 to 12 | 12 | 0 to 3 | See Note 4 |
|   | 20 × f <sub>OUT</sub>         | 2, 4, 5, 6, 8, 10, 12, 16, 20, 24                               | 1, 2, 3, 4, 5, 6, 8, 10, 12, 16                                 | 1, 2, 3, 4, 5, 6, 8  | 1, 2, 3, 4  | 3  | 4 | 2 | 1 | 1  | 8 to 12 | 12 | 0 to 3 | See Note 4 |
|   | 15 × f <sub>OUT</sub>         | 3, 6, 12  | 3, 6, 12  | 3, 6   |   | 4  | 4 | 3 | 2 | 0  | 8 to 12 | 12 | 0 to 3 | See Note 4 |
| 8   | 60 × f <sub>OUT</sub>         | 6, 12, 24, 48   | 6, 12, 24, 48   | 6, 12, 24  |   | 2  | 8 | 6 | 1 | 0  | 8 to 12 | 12 | 0 to 3 | See Note 4 |
|   | 30 × f <sub>OUT</sub>         | 6, 12, 24   | 6, 12, 24   | 6, 12  |   | 4  | 8 | 3 | 1 | 0  | 8 to 12 | 12 | 0 to 3 | See Note 4 |

<sup>1</sup> Due to the internal clock requirements, only certain decimation rates are supported for certain link parameters.

<sup>2</sup> f<sub>ADC\_CLK</sub> is the ADC sample rate; DCM is the chip decimation ratio; f<sub>OUT</sub> is the output sample rate = f<sub>ADC\_CLK</sub>/DCM; SLR is the JESD204B serial lane rate. The following equations must be met due to internal clock divider requirements: SLR ≥ 1.6875 Gbps and SLR ≤ 15.5 Gbps; SLR/40 ≤ f<sub>ADC\_CLK</sub>; least common multiple (20 × DCM × f<sub>OUT</sub>/SLR, DCM) ≤ 64. When the SLR is ≤ 15500 Mbps and > 13500 Mbps, Register 0x056E must be set to 0x30. When the SLR is ≤ 13500 Mbps and ≥ 6750 Mbps, Register 0x056E must be set to 0x00. When the SLR is < 6750 Mbps and ≥ 3375 Mbps, Register 0x056E must be set to 0x10. When the SLR is < 3375 Mbps and ≥ 1687.5 Mbps, Register 0x056E must be set to 0x50.

<sup>3</sup> JESD204B transport layer descriptions are as follows: L is the number of lanes per converter device (lanes per link); M is the number of virtual converters per converter device (virtual converters per link); F is the octets per frame; S is the samples transmitted per virtual converter per frame cycle; HD is the high density mode; N is the virtual converter resolution (in bits); N' is the total number of bits per sample (JESD204B word size); CS is the number of control bits per conversion sample; K is the number of frames per multiframe.

<sup>4</sup> Only valid K × F values that are divisible by 4 are supported: for F = 1, K = 20, 24, 28, 32; for F = 2, K = 12, 16, 20, 24, 28, 32; for F = 4, K = 8, 12, 16, 20, 24, 28, 32; for F = 8, K = 4, 8, 12, 16, 20, 24, 28, 32; and for F = 16, K = 4, 8, 12, 16, 20, 24, 28, 32.

Table 32. JESD204B Output Configurations for N' = 8<sup>1</sup>

| No. of Virtual Converters Supported (Same Value as M) | Serial Lane Rate <sup>2</sup> | Supported Decimation Rates for Lane Rate = 1.7 Gbps to 3.4 Gbps | Supported Decimation Rates for Lane Rate = 3.4 Gbps to 6.8 Gbps | Supported Decimation Rates for Lane Rate = 6.8 Gbps to 13.5 Gbps | Supported Decimation Rates for Lane Rate = 13.5 Gbps to 15.5 Gbps | JESD204B Transport Layer Settings <sup>3</sup> |   |   |   |    |        |    |        |            |
|---|-------------------------------|---|---|--|---|--|---|---|---|----|--------|----|--------|------------|
|   |                               |   |   |  |   | L  | M | F | S | HD | N      | N' | CS     | K          |
| 1   | 10 × f <sub>OUT</sub>         | 1, 2, 3, 4, 5, 6, 8, 10, 12                                     | 1, 2, 3, 4, 5, 6, 8   | 1, 2, 3, 4   | 1, 2  | 1  | 1 | 1 | 1 | 0  | 7 to 8 | 8  | 0 to 1 | See Note 4 |
| 1   | 10 × f <sub>OUT</sub>         | 1, 2, 3, 4, 5, 6, 8, 10, 12                                     | 1, 2, 3, 4, 5, 6, 8   | 1, 2, 3, 4   | 1, 2  | 1  | 1 | 2 | 2 | 0  | 7 to 8 | 8  | 0 to 1 | See Note 4 |
| 1   | 5 × f <sub>OUT</sub>          | 1, 2, 3, 4, 5, 6, 8   | 1, 2, 3, 4  | 1, 2   | 1   | 2  | 1 | 1 | 2 | 0  | 7 to 8 | 8  | 0 to 1 | See Note 4 |
| 1   | 5 × f <sub>OUT</sub>          | 1, 2, 3, 4, 5, 6, 8   | 1, 2, 3, 4  | 1, 2   | 1   | 2  | 1 | 2 | 4 | 0  | 7 to 8 | 8  | 0 to 1 | See Note 4 |
| 1   | 5 × f <sub>OUT</sub>          | 1, 2, 3, 4, 5, 6, 8   | 1, 2, 3, 4  | 1, 2   | 1   | 2  | 1 | 4 | 8 | 0  | 7 to 8 | 8  | 0 to 1 | See Note 4 |
| 1   | 2.5 × f <sub>OUT</sub>        | 1, 2, 3, 4  | 1, 2  | 1  | 1   | 4  | 1 | 1 | 4 | 0  | 7 to 8 | 8  | 0 to 1 | See Note 4 |
| 1   | 2.5 × f <sub>OUT</sub>        | 1, 2, 3, 4  | 1, 2  | 1  | 1   | 4  | 1 | 2 | 8 | 0  | 7 to 8 | 8  | 0 to 1 | See Note 4 |
| 2   | 20 × f <sub>OUT</sub>         | 2, 4, 5, 6, 8, 10, 12, 15, 16, 20, 24, 30                       | 1, 2, 3, 4, 5, 6, 8, 10, 12, 15, 16                             | 1, 2, 3, 4, 5, 6, 8  | 1, 2, 3, 4  | 1  | 2 | 2 | 1 | 0  | 7 to 8 | 8  | 0 to 1 | See Note 4 |
| 2   | 10 × f <sub>OUT</sub>         | 1, 2, 3, 4, 5, 6, 8, 10, 12, 15, 16                             | 1, 2, 3, 4, 5, 6, 8   | 1, 2, 3, 4   | 1, 2  | 2  | 2 | 1 | 1 | 0  | 7 to 8 | 8  | 0 to 1 | See Note 4 |
| 2   | 10 × f <sub>OUT</sub>         | 1, 2, 3, 4, 5, 6, 8, 10, 12, 15, 16                             | 1, 2, 3, 4, 5, 6, 8   | 1, 2, 3, 4   | 1, 2  | 2  | 2 | 2 | 2 | 0  | 7 to 8 | 8  | 0 to 1 | See Note 4 |
| 2   | 5 × f <sub>OUT</sub>          | 1, 2, 3, 4, 5, 6, 8   | 1, 2, 3, 4  | 1, 2   | 1   | 4  | 2 | 1 | 2 | 0  | 7 to 8 | 8  | 0 to 1 | See Note 4 |
| 2   | 5 × f <sub>OUT</sub>          | 1, 2, 3, 4, 5, 6, 8   | 1, 2, 3, 4  | 1, 2   | 1   | 4  | 2 | 2 | 4 | 0  | 7 to 8 | 8  | 0 to 1 | See Note 4 |
| 2   | 5 × f <sub>OUT</sub>          | 1, 2, 3, 4, 5, 6, 8   | 1, 2, 3, 4  | 1, 2   | 1   | 4  | 2 | 4 | 8 | 0  | 7 to 8 | 8  | 0 to 1 | See Note 4 |

<sup>1</sup> Due to the internal clock requirements, only certain decimation rates are supported for certain link parameters.

<sup>2</sup> f<sub>ADC\_CLK</sub> is the ADC sample rate; DCM is the chip decimation ratio; f<sub>OUT</sub> is the output sample rate = f<sub>ADC\_CLK</sub>/DCM; SLR is the JESD204B serial lane rate. The following equations must be met due to internal clock divider requirements: SLR ≥ 1.6875 Gbps and SLR ≤ 15.5 Gbps; SLR/40 ≤ f<sub>ADC\_CLK</sub>; least common multiple (20 × DCM × f<sub>OUT</sub>/SLR, DCM) ≤ 64. When the SLR is ≤ 15500 Mbps and > 13500 Mbps, Register 0x056E must be set to 0x30. When the SLR is ≤ 13500 Mbps and ≥ 6750 Mbps, Register 0x056E must be set to 0x00. When the SLR is < 6750 Mbps and ≥ 3375 Mbps, Register 0x056E must be set to 0x10. When the SLR is < 3375 Mbps and ≥ 1687.5 Mbps, Register 0x056E must be set to 0x50.

<sup>3</sup> JESD204B transport layer descriptions are as follows: L is the number of lanes per converter device (lanes per link); M is the number of virtual converters per converter device (virtual converters per link); F is the octets per frame; S is the samples transmitted per virtual converter per frame cycle; HD is the high density mode; N is the virtual converter resolution (in bits); N' is the total number of bits per sample (JESD204B word size); CS is the number of control bits per conversion sample; K is the number of frames per multiframe.

<sup>4</sup> Only valid K × F values that are divisible by 4 are supported: for F = 1, K = 20, 24, 28, 32; for F = 2, K = 12, 16, 20, 24, 28, 32; for F = 4, K = 8, 12, 16, 20, 24, 28, 32; for F = 8, K = 4, 8, 12, 16, 20, 24, 28, 32; and for F = 16, K = 4, 8, 12, 16, 20, 24, 28, 32.

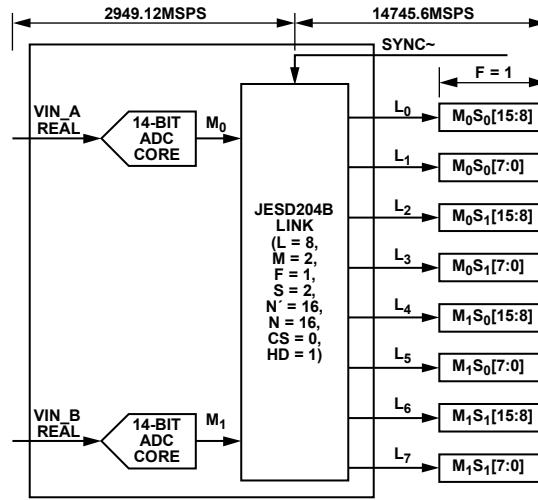
**Example 1—Full Bandwidth Mode**

I = REAL COMPONENT  
 Q = QUADRATURE COMPONENT  
 DCM = DECIMATION  
 C2R = COMPLEX TO REAL  
 M<sub>x</sub> = VIRTUAL CONVERTER X  
 L<sub>y</sub> = LANE Y  
 S<sub>z</sub> = SAMPLE Z INSIDE A JESD204B FRAME  
 C = CONTROL BIT (OVERRANGE, AMONG OTHERS)  
 T = TAIL BIT

15547-111

Figure 116. Full Bandwidth Mode

The AD9208 is set up as shown in Figure 116, with the following configurations:

- Two 14-bit converters at 2.94912 GSPS.
- Full bandwidth application layer mode.
- Decimation filters bypassed.

The JESD204B output configuration is as follows:

- Two virtual converters required (see Table 33).
- Output sample rate ( $f_{OUT}$ ) =  $2949.12/1 = 2949.12$  MSPS.

The JESD204B supported output configurations are as follows (see Table 33):

- N' = 16 bits.
- N = 14 bits.
- L = 8, M = 2, and F = 1, or L = 8, M = 2, and F = 2.
- CS = 0.
- K = 32.
- Output serial lane rate = 14.7456 Gbps per lane.
- The PLL control register, Register 0x056E, is set to 0x30.

**Example 2—ADC with DDC Option (Two ADCs Plus Two DDCs)**

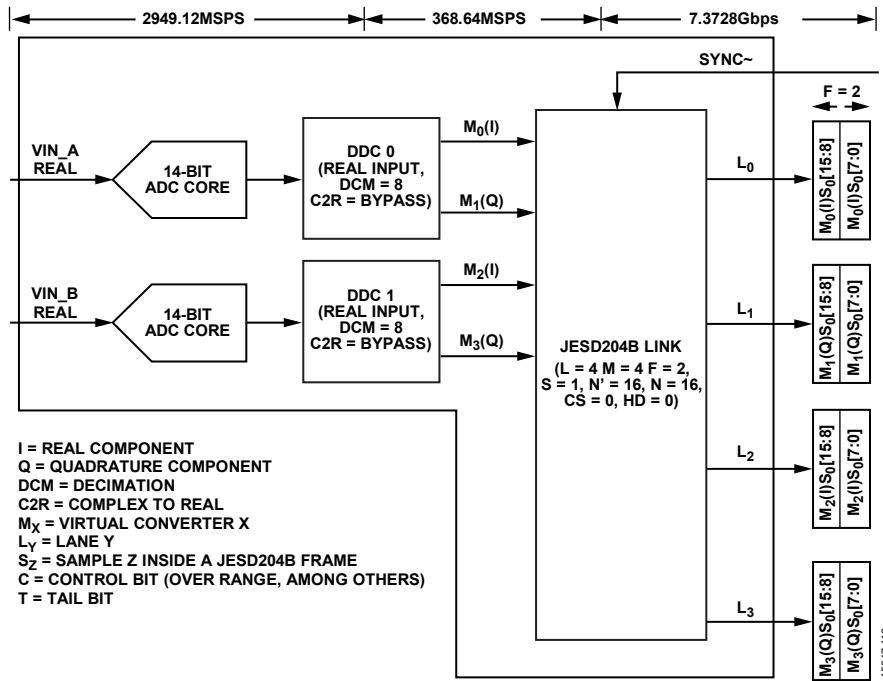

Figure 117. Two ADCs Plus Two DDCs Mode (L = 4, M = 4, F = 2, S = 1)

This example shows the flexibility in the digital and lane configurations for the AD9208. The sample rate is 2.94912 GSPS; however, the outputs are all combined in either two or four lanes, depending on the input/output speed capability of the receiving device.

The AD9208 is set up as shown in Figure 117, with the following configuration:

- Two 14-bit converters at 2.94912 GSPS.
- Two DDC application layer mode with complex outputs (I/Q).
- Chip decimation ratio = 8.
- DDC decimation ratio = 8 (see Table 46).

The JESD204B output configuration is as follows:

- Four virtual converters required (see Table 33).
- Output sample rate ( $f_{OUT}$ ) = 2949.12/8 = 368.64 MSPS.

The JESD204B supported output configurations are as follows (see Table 33):

- N' = 16 bits.
- N = 14 bits .
- L = 2, M = 4, and F = 4, or L = 4, M = 4, and F = 2.
- CS = 0.
- K = 32.
- Output serial lane rate = 14.7456 Gbps per lane (L = 2) or 7.3728 Gbps per lane (L = 4).

For L = 2, set the PLL control register, Register 0x056E, to 0x30.  
 For L = 4, set the PLL control register, Register 0x056E, to 0x00.

## DETERMINISTIC LATENCY

Both ends of the JESD204B link contain various clock domains distributed throughout each system. Data traversing from one clock domain to a different clock domain can lead to ambiguous delays in the JESD204B link. These ambiguities lead to non-repeatable latencies across the link from one power cycle or link reset to the next. Section 6 of the JESD204B specification addresses the issue of deterministic latency with mechanisms defined as Subclass 1 and Subclass 2.

The AD9208 supports JESD204B Subclass 0 and Subclass 1 operation. Register 0x0590, Bits[7:5] set the subclass mode for the AD9208 and its default is set for Subclass 1 operating mode (Register 0x0590, Bit 5 = 1). If deterministic latency is not a system requirement, Subclass 0 operation is recommended and the SYSREF signal may not be required. Even in Subclass 0 mode, the SYSREF signal may be required in an application where multiple AD9208 devices must be synchronized with each other. This topic is addressed in the Timestamp Mode section.

### SUBCLASS 0 OPERATION

If there is no requirement for multichip synchronization while operating in Subclass 0 mode (Register 0x0590, Bits[7:5]= 0), the SYSREF input can be left disconnected. In this mode, the relationship of the JESD204B clocks between the JESD204B transmitter and receiver are arbitrary, but does not affect the ability of the receiver to capture and align the lanes within the link.

### SUBCLASS 1 OPERATION

The JESD204B protocol organizes data samples into octets, frames, and multiframe as described in the Transport Layer section. The LMFC is synchronous with the beginnings of these multiframe. In Subclass 1 operation, the SYSREF is used to synchronize the LMFCs for each device in a link or across multiple links (within the AD9208, SYSREF also synchronizes the internal sample dividers), as shown in Figure 118. The JESD204B receiver uses the multiframe boundaries and buffering to achieve consistent latency across lanes (or even multiple devices), and also to achieve a fixed latency between power cycles and link reset conditions.

#### Deterministic Latency Requirements

Several key factors are required for achieving deterministic latency in a JESD204B Subclass 1 system.

- SYSREF± signal distribution skew within the system must be less than the desired uncertainty for the system.
- SYSREF± setup and hold time requirements must be met for each device in the system.
- The total latency variation across all lanes, links, and devices must be  $\leq 1$  LMFC periods (see Figure 118). This includes both variable delays and the variation in fixed delays from lane to lane, link to link, and device to device in the system.

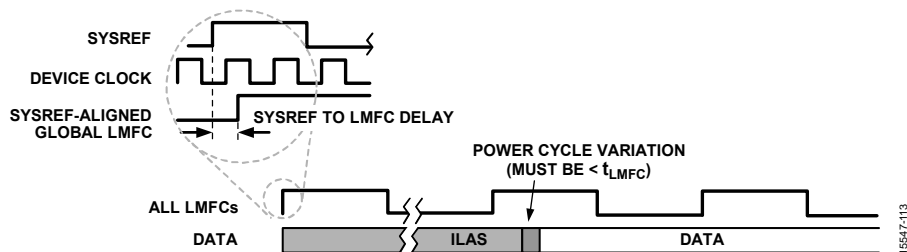

Figure 118. SYSREF and LMFC

**Setting Deterministic Latency Registers**

The JESD204B receiver in the logic device buffers data starting on the LMFC boundary. If the total link latency in the system is near an integer multiple of the LMFC period, it is possible that from one power cycle to the next, the data arrival time at the receive buffer may straddle an LMFC boundary. To ensure deterministic latency in this case, a phase adjustment of the LMFC at either the transmitter or receiver must be performed. Typically, adjustments to accommodate the receive buffer are made to the LMFC of the receiver. Alternatively, this adjustment can be made in the AD9208 using the LMFC offset register (Register 0x0578, Bits[4:0]). This delays the LMFC in frame clock increments, depending on the F parameter (number of octets per lane per frame). For F = 1, every fourth setting (0, 4, 8, and so on) is valid and results in a four frame clock shift. For F = 2, every other setting (0, 2, 4, and so on) is valid and results in a two frame clock shift. For all other values of F, each setting results in a one frame clock shift. Figure 119 shows that, when the link latency is near an LMFC boundary, the local LMFC of the AD9208 can be adjusted to delay the data arrival time at the receiver. Figure 120 shows how the LMFC of the receiver is delayed to accommodate the receive buffer timing. Consult the applicable JESD204B receiver user guide for details on making

this adjustment. If the total latency in the system is not near an integer multiple of the LMFC period or if the appropriate adjustments have been made to the LMFC phase at the clock source, it is still possible to have variable latency from one power cycle to the next. By design, the AD9208 has circuitry in place to minimize this variation from power-up to power-up. In this case, the user must check for the possibility that the setup and hold time requirements for the SYSREF signal are not being met, by reading the SYSREF setup/hold monitor register (Register 0x0128). This function is fully described in the SYSREF± Setup/Hold Window Monitor section.

If reading Register 0x0128 indicates there may be a timing problem, there are a few adjustments that can be made in the AD9208. Changing the SYSREF level that is used for alignment is possible using the SYSREF transition select bit (Register 0x0120, Bit 4). Also, changing which edge of CLK is used to capture SYSREF can be done using the CLK edge select bit (Register 0x0120, Bit 3). Both of these options are described in the SYSREF Control Features section. If neither of these measures helps to achieve an acceptable setup and hold time, adjusting the phase of SYSREF and/or the device clock (CLK±) may be required.

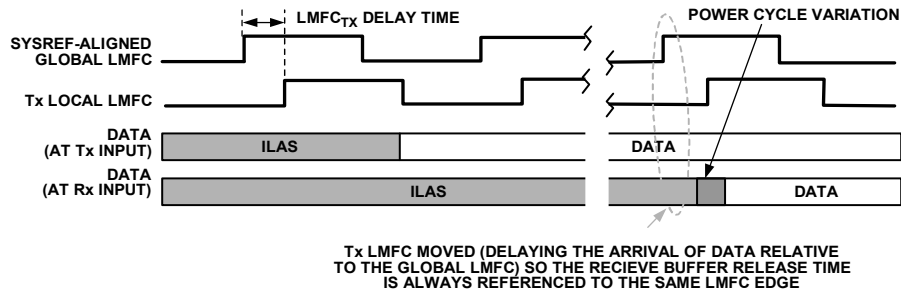

Figure 119. Adjusting the JESD204B Tx LMFC in the AD9208

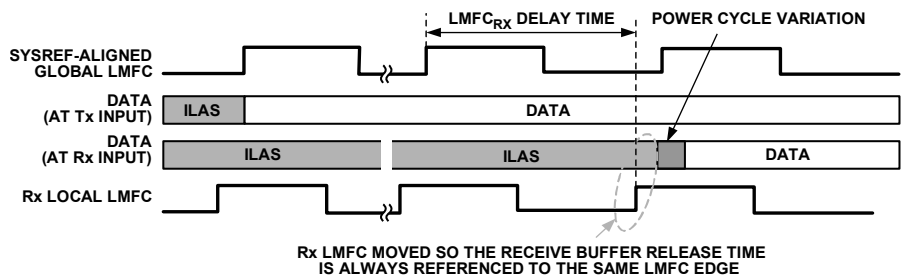

Figure 120. Adjusting the JESD204B Rx LMFC in the Logic Device

## MULTICHIP SYNCHRONIZATION

The flowchart in Figure 122 shows the internal mechanism for multichip synchronization in the AD9208. There are two methods by which multichip synchronization can take place, as determined by the chip synchronization mode bit (Register 0x01FF, Bit 0). Each method involves different applications of the SYSREF signal.

### NORMAL MODE

The default state of the chip synchronization mode bit is 0, which configures the AD9208 for normal chip synchronization. The JESD204B standard specifies the use of SYSREF to provide for deterministic latency within a single link. This same concept, when applied to a system with multiple converters and logic devices can also provide multichip synchronization. In Figure 122, this is referred to as normal mode. Following the process in the flowchart ensures that the AD9208 is configured appropriately. The user must also consult the logic devices user IP guide to ensure that the JESD204B receivers are configured appropriately.

### TIMESTAMP MODE

For all AD9208 full bandwidth operating modes, the SYSREF input can also be used to timestamp samples. This is another method by which multiple channels and multiple devices can achieve synchronization. This method is especially effective when synchronizing multiple devices to one or more logic devices. The logic devices buffer the data streams, identify the timestamped samples, and align them. When the chip synchronization mode bit (Register 0x01FF, Bit 0) is set to 1, the timestamp method is

used for synchronization of multiple channels and/or devices. In this mode, SYSREF resets the sample dividers and the JESD204B clocking. When the chip sync mode is set to 1, the clocks are not reset; instead, the coinciding sample is timestamped using the JESD204B control bits of that sample. To operate in timestamp mode, these additional settings are necessary:

- Continuous or N-shot SYSREF must be enabled (Register 0x0120, Bits[2:1] = 1 or 2).
- At least one control bit must be enabled (Register 0x058F, Bits[7:6] = 1, 2, or 3).
- Set the function for one of the control bits to SYSREF:
  - Register 0x0559, Bits[3:0] = 5 if using Control Bit 0.
  - Register 0x0559, Bits[7:4] = 5 if using Control Bit 1.
  - Register 0x055A, Bits[3:0] = 5 if using Control Bit 2.

Figure 121 shows how the input sample coincident with SYSREF is timestamped and ultimately output of the ADC. In this example, there are two control bits, and Control Bit 0 is the bit indicating which sample was coincident with the SYSREF rising edge. Note that the pipeline latencies for each channel are identical. If so desired, the SYSREF timestamp delay register (Register 0x0123) can be used to adjust the timing of which sample is time stamped.

Note that time stamping is not supported by any AD9208 operating modes that use decimation.

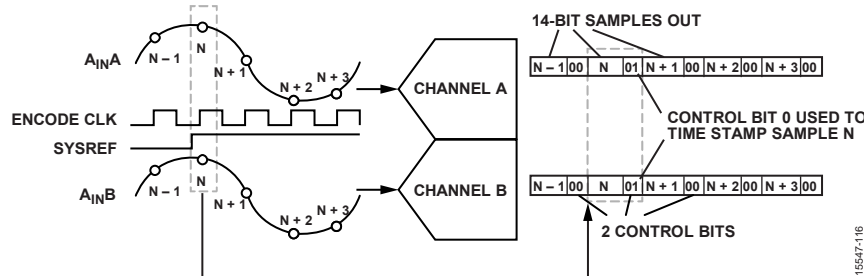

Figure 121. AD9208 Timestamping Example—CS = 2 (Register 0x058F, Bits[7:6] = 2), Control Bit 0 is SYSREF (Register 0x0559, Bits[3:0] = 5)



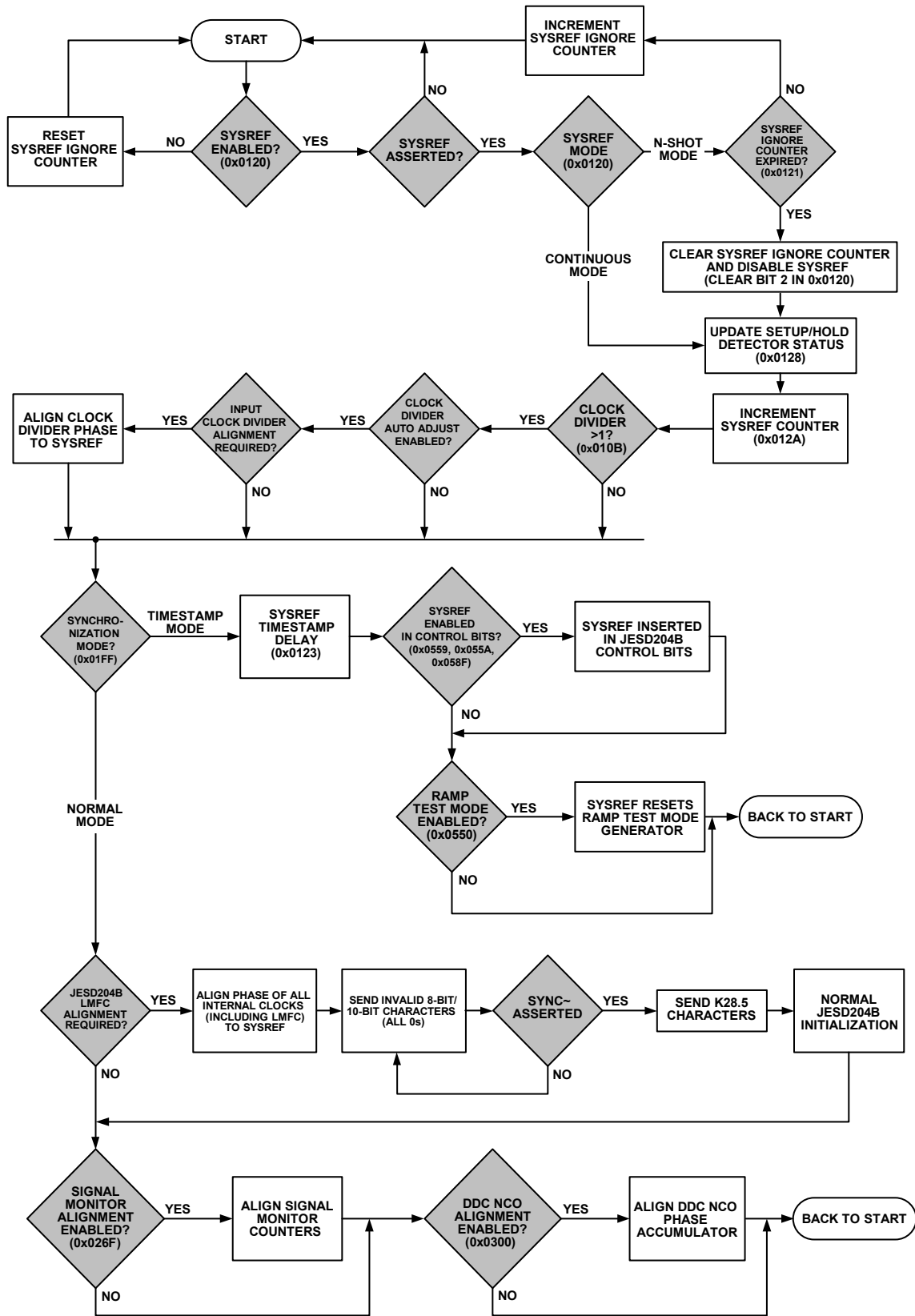

Figure 122. SYSREF Capture Scenarios and Multichip Synchronization

15547-117

## SYSREF INPUT

The SYSREF input signal is used as a high accuracy system reference for deterministic latency and multichip synchronization. The AD9208 accepts a single-shot or periodic input signal. The SYSREF mode select bits (Register 0x0120, Bits[2:1]) select the input signal type and also arm the SYSREF state machine when set. If in single (or N) shot mode (Register 0x0120, Bits[2:1] = 2), the SYSREF mode select bit self clears after the appropriate SYSREF transition is detected. The pulse width must have a minimum width of two CLK± periods. If the clock divider (Register 0x010B, Bits[3:0]) is set to a value other than divide by 1, multiply this minimum pulse width requirement by the divide ratio (that is, if set to divide by 8, the minimum pulse width is 16 CLK± cycles). When using a continuous SYSREF signal (Register 0x0120, Bits[2:1] = 1), the period of the SYSREF signal must be an integer multiple of the LMFC. LMFC can be derived using the following formula:

$$LMFC = ADC\ clock / (S \times K)$$

where:

S is the JESD204B parameter for number of samples per converter.  
K is the number of frames per multiframe.

The input clock divider, DDCs, signal monitor block, and JESD204B link are all synchronized using the SYSREF± input when in normal synchronization mode (Register 0x01FF, Bit 0 = 0). The SYSREF± input can also be used to timestamp an ADC sample to provide a mechanism for synchronizing multiple AD9208 devices in a system. For the highest level of timing accuracy, SYSREF± must meet setup and hold requirements relative to the CLK± input. There are several features in the AD9208 that can be used to ensure these requirements are met; these features are described in the SYSREF Control Features section.

### SYSREF Control Features

SYSREF is used, along with the input clock (CLK), as part of a source-synchronous timing interface and requires setup and hold timing requirements of -65 ps and 95 ps relative to the input clock (see Figure 123). The AD9208 has several features that aid users in meeting these requirements. First, the SYSREF sample event can be defined as either a synchronous low to high transition or synchronous high to low transition. Second, the AD9208 allows the SYSREF signal to be sampled using either the rising edge or falling edge of the input clock. Figure 123, Figure 124, Figure 125, and Figure 126 show all four possible combinations.

The third SYSREF related feature available is the ability to ignore a programmable number (up to 16) of SYSREF events. The AD9208 is able to ignore N SYSREF events (note that the SYSREF ignore feature is enabled by setting the SYSREF mode register (Register 0x0120, Bits[2:1]) to 2'b10, which is labeled as N-shot mode. This feature is useful for handling periodic SYSREF signals, which need time to settle after startup. Ignoring SYSREF until the clocks in the system have settled can avoid an inaccurate SYSREF trigger. Figure 127 shows an example of the SYSREF ignore feature when ignoring three SYSREF events.

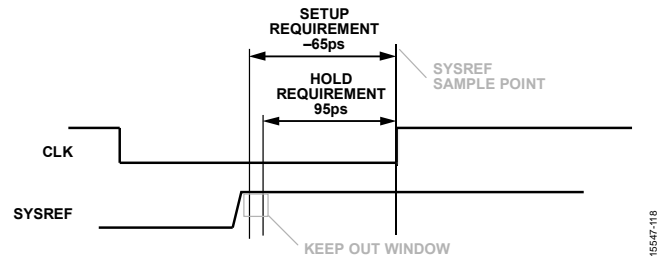

Figure 123. SYSREF Setup and Hold Time Requirements—SYSREF Low to High Transition Using Rising Edge Clock (Default)

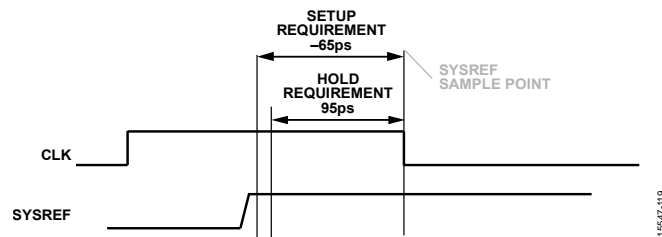

Figure 124. SYSREF Low to High Transition Using Falling Edge Clock Capture (Register 0x0120, Bit 4 = 1'b0; Register 0x0120, Bit 3 = 1'b1)

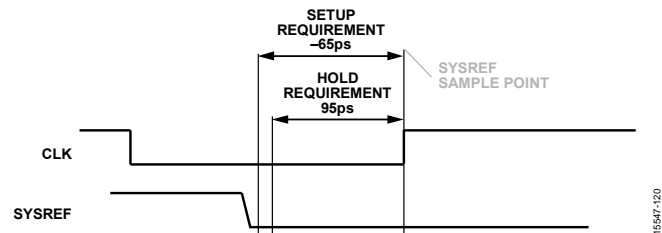

Figure 125. SYSREF High to Low Transition Using Rising Edge Clock Capture (Register 0x0120, Bit 4 = 1'b1; Register 0x0120, Bit 3 = 1'b0)

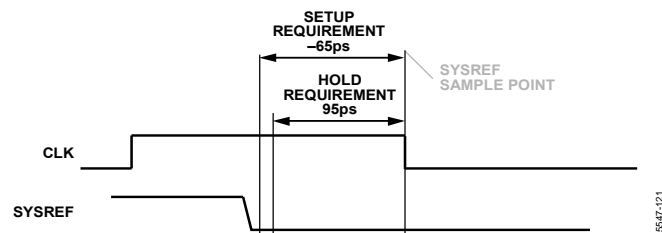

Figure 126. SYSREF High to Low Transition Using Falling Edge Clock Capture (Register 0x0120, Bit 4 = 1'b1; Register 0x0120, Bit 3 = 1'b1)

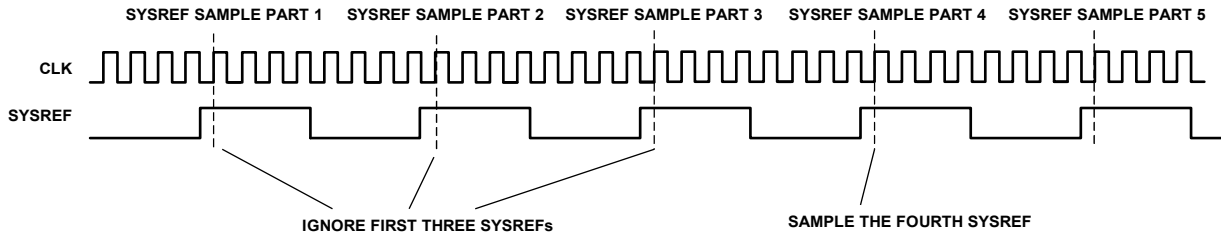

Figure 127. SYSREF Ignore Example (SYSREF Ignore Count, Register 0x0121, Bits[3:0] = 3)

18547-122

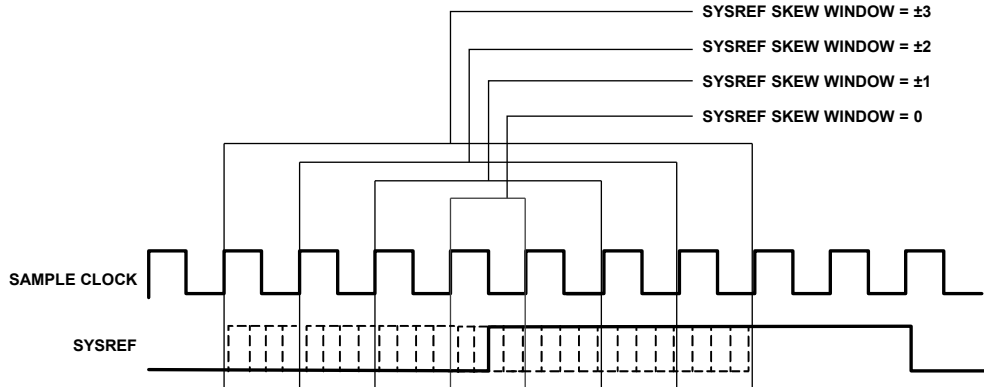

Figure 128. SYSREF Skew Window

18547-123

When in continuous SYSREF mode (Register 0x0120, Bits[2:1] = 1), the AD9208 monitors the placement of the SYSREF leading edge compared to the internal LMFC. If the SYSREF is captured with a clock edge other than the one that is aligned with LMFC, the AD9208 initiates a resynchronization of the link. Because input clock rates for AD9208 can be up to 4 GHz, the AD9208 provides another SYSREF related feature that makes it possible to accommodate periodic SYSREF signals where cycle accurate capture is not feasible or not required. For these scenarios, the AD9208 has a programmable SYSREF skew window that allows the internal dividers to remain undisturbed unless SYSREF occurs outside the skew window. The resolution of the SYSREF skew window is set in sample clock cycles. If the SYSREF negative skew window is 1 and the positive skew window is 1, the total skew window is  $\pm 1$  sample clock cycles, meaning that, as long as

SYSREF is captured within  $\pm 1$  sample clock cycle of the clock that is aligned with LMFC, the link continues to operate normally. If the SYSREF has jitter, which can cause a misalignment between SYSREF and LMFC, this feature allows the system to continue running without a resynchronization, while still allowing the device to monitor for larger errors not caused by jitter. For the AD9208, the positive and negative skew window is controlled by the SYSREF window negative register (Register 0x0122, Bits[3:2]) and SYSREF window positive register (Register 0x0122, Bits[1:0]). Figure 128 shows information on the location of the skew window settings relative to Phase 0 of the internal dividers. Negative skew is defined as occurring before the internal dividers reach Phase 0, and positive skew is defined after the internal dividers reach Phase 0.

**SYSREF± SETUP/HOLD WINDOW MONITOR**

To ensure a valid SYSREF signal capture, the AD9208 has a SYSREF± setup/hold window monitor. This feature allows the system designer to determine the location of the SYSREF± signals relative to the CLK± signals by reading back the amount of setup/hold margin on the interface through the memory map. Figure 129 and Figure 130 show the setup and hold status values

for different phases of SYSREF±. The setup detector returns the status of the SYSREF± signal before the CLK± edge, and the hold detector returns the status of the SYSREF signal after the CLK± edge. Register 0x0128 stores the status of SYSREF± and notifies the user if the SYSREF± signal is captured by the ADC.

Table 36 shows the description of the contents of Register 0x0128 and how to interpret them.

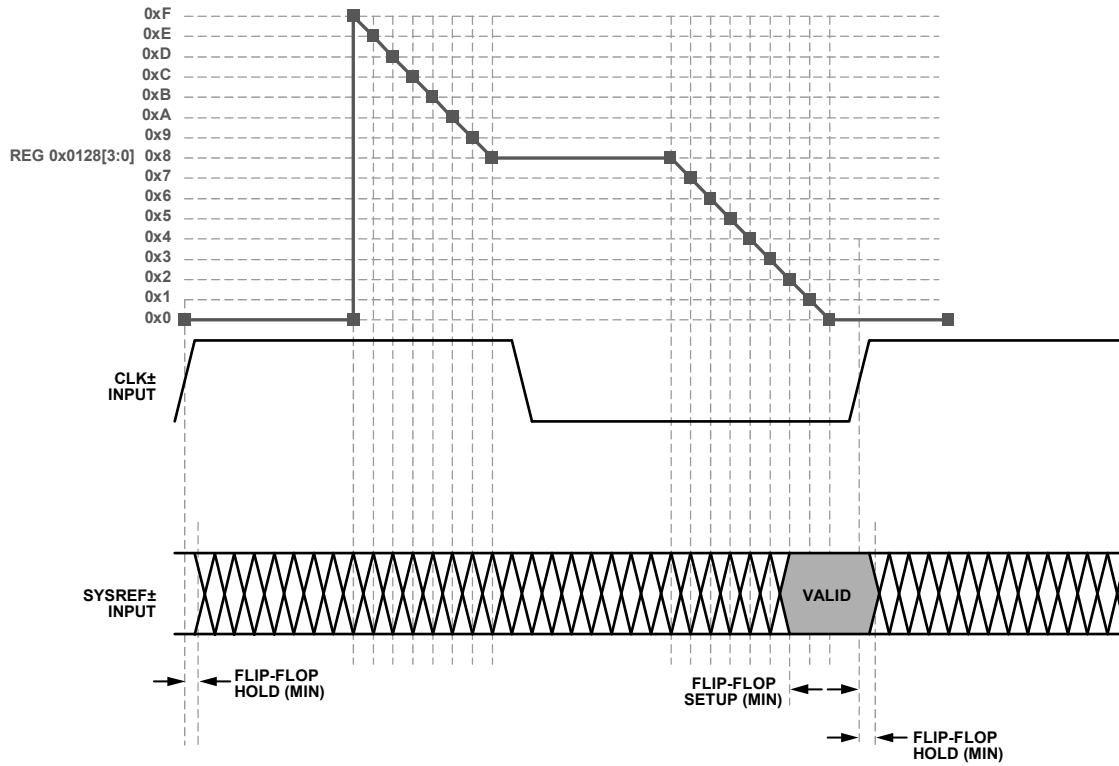

Figure 129. SYSREF± Setup Detector

15547-124

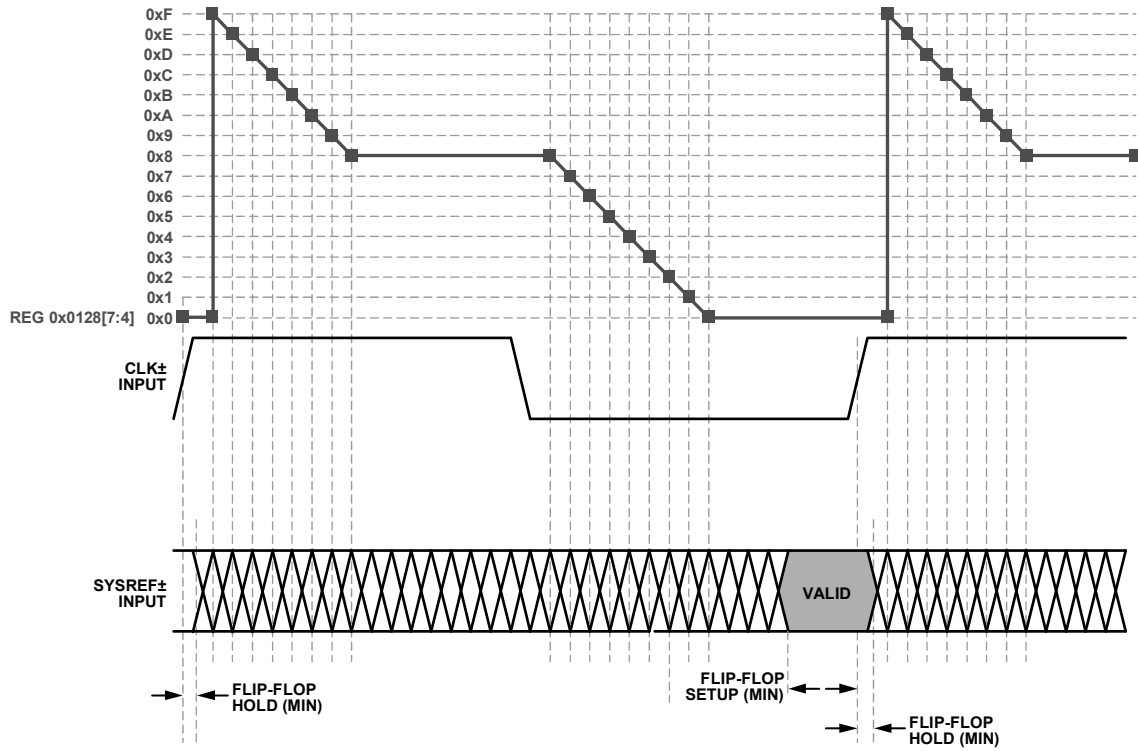

Figure 130. SYSREF± Hold Detector

15547-125

Table 36. SYSREF± Setup/Hold Monitor, Register 0x0128

| Register 0x0128, Bits[7:4]<br>Hold Status | Register 0x0128, Bits[3:0]<br>Setup Status | Description  |
|---|--|--|
| 0x0                                       | 0x0 to 0x7                                 | Possible setup error. The smaller this number, the smaller the setup margin. |
| 0x0 to 0x8                                | 0x8  | No setup or hold error (best hold margin).                                   |
| 0x8                                       | 0x9 to 0xF                                 | No setup or hold error (best setup and hold margin).                         |
| 0x8                                       | 0x0  | No setup or hold error (best setup margin).                                  |
| 0x9 to 0xF                                | 0x0  | Possible hold error. The larger this number, the smaller the hold margin.    |
| 0x0                                       | 0x0  | Possible setup or hold error.  |

## LATENCY

### END TO END TOTAL LATENCY

Total latency in the [AD9208](#) is dependent on the chip application mode and the JESD204B configuration. For any given combination of these parameters, the latency is deterministic, however, the value of this deterministic latency must be calculated as described in the Example Latency Calculations section.

Table 34 shows the combined latency through the ADC and DSP for the different chip application modes supported by the [AD9208](#). Table 35 shows the latency through the JESD204B block for each application mode based on the M/L ratio. For both tables, latency is typical and is in units of the encode clock. The latency through the JESD204B block does not depend on the output data type (real or complex). Therefore, data type is not included in Table 35.

To determine the total latency, select the appropriate ADC + DSP latency from Table 34 and add it to the appropriate JESD204B latency from Table 35. Example calculations are provided in the following section.

### EXAMPLE LATENCY CALCULATIONS

Example Configuration 1 is as follows:

- ADC application mode = full bandwidth
- Real outputs
- $L = 8, M = 2, F = 1, S = 2$  (JESD204B mode)
- $20 \times (M/L) = 5$
- Latency =  $31 + 44 = 75$  encode clocks

Example Configuration 2 is as follows:

- ADC application mode = DCM4
- Complex outputs
- $L = 4, M = 2, F = 1, S = 1$  (JESD204B mode)
- $20 \times (M/L) = 10$
- Latency =  $162 + 88 = 250$  encode clocks

### LMFC REFERENCED LATENCY

Some FPGA vendors may require the end user to know LMFC-referenced latency to make appropriate deterministic latency adjustments. If they are required, the latency values in Table 34 and Table 35 can be used for the analog in to LMFC and LMFC to data out latency values.

Table 37. Latency Through the ADC + DSP Blocks (Number of Sample Clocks)<sup>1</sup>

| Chip Application Mode | Enabled Filters             | ADC + DSP Latency |
|-----------------------|-----------------------------|-------------------|
| Full Bandwidth        | Not applicable              | 31                |
| DCM1 (Real)           | HB1                         | 90                |
| DCM2 (Complex)        | HB1                         | 90                |
| DCM3 (Complex)        | TB1                         | 102               |
| DCM2 (Real)           | HB2 + HB1                   | 162               |
| DCM4 (Complex)        | HB2 + HB1                   | 162               |
| DCM3 (Real)           | TB2 + HB1                   | 212               |
| DCM6 (Complex)        | TB2 + HB1                   | 212               |
| DCM4 (Real)           | HB3 + HB2 + HB1             | 292               |
| DCM8 (Complex)        | HB3 + HB2 + HB1             | 292               |
| DCM5 (Real)           | FB2 + HB1                   | 380               |
| DCM10 (Complex)       | FB2 + HB1                   | 380               |
| DCM6 (Real)           | TB2 + HB2 + HB1             | 424               |
| DCM12 (Complex)       | TB2 + HB2 + HB1             | 424               |
| DCM15 (Real)          | FB2 + TB1                   | 500               |
| DCM8 (Real)           | HB4 + HB3 + HB2 + HB1       | 552               |
| DCM16 (Complex)       | HB4 + HB3 + HB2 + HB1       | 552               |
| DCM10 (Real)          | FB2 + HB2 + HB1             | 694               |
| DCM20 (Complex)       | FB2 + HB2 + HB1             | 694               |
| DCM12 (Real)          | TB2 + HB3 + HB2 + HB1       | 814               |
| DCM24 (Complex)       | TB2 + HB3 + HB2 + HB1       | 814               |
| DCM30 (Complex)       | HB2 + FB2 + TB1             | 836               |
| DCM20 (Real)          | FB2 + HB3 + HB2 + HB1       | 1420              |
| DCM40 (Complex)       | FB2 + HB3 + HB2 + HB1       | 1420              |
| DCM24 (Real)          | TB2 + HB4 + HB3 + HB2 + HB1 | 1594              |
| DCM48 (Complex)       | TB2 + HB4 + HB3 + HB2 + HB1 | 1594              |

<sup>1</sup> DCMx indicates the decimation ratio.

Table 38. Latency Through JESD204B Block (Number of Sample Clocks)<sup>1</sup>

| Chip Application Mode | M/L Ratio <sup>2</sup> |                  |                  |                  |                  |                  |                 |
|-----------------------|------------------------|------------------|------------------|------------------|------------------|------------------|-----------------|
|                       | 0.125                  | 0.25             | 0.5              | 1                | 2                | 4                | 8               |
| Full Bandwidth        | 82                     | 44               | 25               | 14               | 7                | 9                | 3               |
| DCM1                  | 82                     | 44               | 25               | 14               | 7                | N/A              | N/A             |
| DCM2                  | 160                    | 84               | 46               | 27               | 14               | 7                | N/A             |
| DCM3                  | 237                    | 124              | 67               | 39               | 21               | 11               | N/A             |
| DCM4                  | 315                    | 164              | 88               | 50               | 27               | 14               | 9               |
| DCM5                  | N/A                    | 203 <sup>3</sup> | 109 <sup>3</sup> | 62 <sup>3</sup>  | 43 <sup>3</sup>  | N/A              | N/A             |
| DCM6                  | N/A                    | 243              | 130              | 73               | 39               | 21               | 14              |
| DCM8                  | N/A                    | 323              | 172              | 96               | 50               | 27               | 18              |
| DCM10                 | N/A                    | N/A              | 213              | 119              | 62               | 33               | 22              |
| DCM12                 | N/A                    | N/A              | 255              | 142              | 73               | 39               | 27              |
| DCM15                 | N/A                    | N/A              | 318 <sup>4</sup> | 176 <sup>4</sup> | 90 <sup>4</sup>  | 47 <sup>4</sup>  | 33 <sup>4</sup> |
| DCM16                 | N/A                    | N/A              | 339 <sup>4</sup> | 188 <sup>4</sup> | 96 <sup>4</sup>  | 50 <sup>4</sup>  | 35 <sup>4</sup> |
| DCM20                 | N/A                    | N/A              | N/A              | 233              | 119              | 62               | 43              |
| DCM24                 | N/A                    | N/A              | N/A              | 279              | 142              | 73               | 51              |
| DCM30                 | N/A                    | N/A              | N/A              | 348 <sup>4</sup> | 176 <sup>4</sup> | 90 <sup>4</sup>  | 62 <sup>4</sup> |
| DCM40                 | N/A                    | N/A              | N/A              | N/A              | 233 <sup>4</sup> | 119 <sup>4</sup> | 82 <sup>4</sup> |
| DCM48                 | N/A                    | N/A              | N/A              | N/A              | 279 <sup>4</sup> | 142 <sup>4</sup> | 97 <sup>4</sup> |

<sup>1</sup> N/A means not applicable and indicates that the application mode is not supported at the M/L ratio listed.

<sup>2</sup> M/L ratio is the number of converters divided by the number of lanes for the configuration.

<sup>3</sup> The application mode at the M/L ratio listed is only supported in real output mode.

<sup>4</sup> The application mode at the M/L ratio listed is only supported in complex output mode.

## TEST MODES

### ADC TEST MODES

The AD9208 has various test options that aid in the system level implementation. The AD9208 has ADC test modes that are available in Register 0x550. These test modes are described in Table 39. When an output test mode is enabled, the analog section of the ADC is disconnected from the digital back-end blocks, and the test pattern is run through the output formatting block. Some of the test patterns are subject to output formatting, and some are not. The PN generators from the PN sequence tests can be reset by setting Bit 4 or Bit 5 of Register 0x0550. These tests can be performed with or without an analog signal (if present, the analog signal is ignored); however, they do require an encode clock.

If the application mode is set to select a DDC mode of operation, the test modes must be enabled for each DDC enabled. The test patterns can be enabled via Bit 2 and Bit 0 of Register 0x0327, Register 0x0347, and Register 0x0367, depending on which DDC(s) are selected. The (I) data uses the test patterns selected for Channel A, and the (Q) data uses the test patterns selected for Channel B. For DDC3 only, the (I) data uses the test patterns from Channel A, and the (Q) data does not output test patterns. Bit 0 of Register 0x0387 selects the Channel A test patterns to be used for the (I) data. For more information, see the [AN-877 Application Note, Interfacing to High Speed ADCs via SPI](#).

Table 39. ADC Test Modes

| Output Test Mode Bit Sequence | Pattern Name          | Expression                         | Default/Seed Value | Sample (N, N + 1, N + 2, ...)  |
|-------------------------------|-----------------------|------------------------------------|--------------------|--|
| 0000                          | Off (default)         | Not applicable                     | Not applicable     | Not applicable   |
| 0001                          | Midscale short        | 0000 0000 0000                     | Not applicable     | Not applicable   |
| 0010                          | +Full-scale short     | 01 1111 1111 1111                  | Not applicable     | Not applicable   |
| 0011                          | –Full-scale short     | 10 0000 0000 0000                  | Not applicable     | Not applicable   |
| 0100                          | Checkerboard          | 10 1010 1010 1010                  | Not applicable     | 0x1555, 0x2AAA, 0x1555, 0x2AAA, 0x1555   |
| 0101                          | PN sequence long      | $x^{23} + x^{18} + 1$              | 0x3AFF             | 0x3FD7, 0x0002, 0x26E0, 0x0A3D, 0x1CA6   |
| 0110                          | PN sequence short     | $x^9 + x^5 + 1$                    | 0x0092             | 0x125B, 0x3C9A, 0x2660, 0x0c65, 0x0697   |
| 0111                          | One-/zero-word toggle | 11 1111 1111 1111                  | Not applicable     | 0x0000, 0x3FFF, 0x0000, 0x3FFF, 0x0000   |
| 1000                          | User input            | Register 0x0551 to Register 0x0558 | Not applicable     | User Pattern 1[15:2], User Pattern 2[15:2], User Pattern 3[15:2], User Pattern 4[15:2], User Pattern 1[15:2] ... for repeat mode<br>User Pattern 1[15:2], User Pattern 2[15:2], User Pattern 3[15:2], User Pattern 4[15:2], 0x0000 ... for single mode |
| 1111                          | Ramp output           | $(x) \% 2^{14}$                    | Not applicable     | $(x) \% 2^{14}, (x + 1) \% 2^{14}, (x + 2) \% 2^{14}, (x + 3) \% 2^{14}$   |



## JESD204B BLOCK TEST MODES

In addition to the ADC pipeline test modes, the AD9208 also has flexible test modes in the JESD204B block. These test modes are listed in Register 0x0573 and Register 0x0574. These test patterns can be injected at various points along the output datapath. These test injection points are shown in Figure 107. Table 40 describes the various test modes available in the JESD204B block. For the AD9208, a transition from test modes (Register 0x0573  $\neq$  0x00) to normal mode (Register 0x0573 = 0x00) requires an SPI soft reset. This is done by writing 0x81 to Register 0x0000 (self cleared).

### Transport Layer Sample Test Mode

The transport layer samples are implemented in the AD9208 as defined by Section 5.1.6.3 in the JEDEC JESD204B specification.

These tests are shown in Register 0x0571, Bit 5. The test pattern is equivalent to the raw samples from the ADC.

### Interface Test Modes

The interface test modes are described in Register 0x0573, Bits[3:0]. These test modes are also explained in Table 40. The interface tests can be injected at various points along the data. See Figure 107 for more information on the test injection points. Register 0x0573, Bits[5:4] show where these tests are injected.

Table 41, Table 42, and Table 43 show examples of some of the test modes when injected at the JESD204B sample input, PHY 10-bit input, and scrambler 8-bit input. UPx in the tables represent the user pattern control bits from the user register map.

Table 40. JESD204B Interface Test Modes

| Output Test Mode Bit Sequence | Pattern Name                | Expression                         | Default                                       |
|-------------------------------|-----------------------------|------------------------------------|---|
| 0000                          | Off (default)               | Not applicable                     | Not applicable                                |
| 0001                          | Alternating checker board   | 0x5555, 0xAAAA, 0x5555, ...        | Not applicable                                |
| 0010                          | 1/0 word toggle             | 0x0000, 0xFFFF, 0x0000, ...        | Not applicable                                |
| 0011                          | 31-bit PN sequence          | $x^{31} + x^{28} + 1$              | 0x0003AFFF                                    |
| 0100                          | 23-bit PN sequence          | $x^{23} + x^{18} + 1$              | 0x003AFF                                      |
| 0101                          | 15-bit PN sequence          | $x^{15} + x^{14} + 1$              | 0x03AF  |
| 0110                          | 9-bit PN sequence           | $x^9 + x^5 + 1$                    | 0x092   |
| 0111                          | 7-bit PN sequence           | $x^7 + x^6 + 1$                    | 0x07  |
| 1000                          | Ramp output                 | $(x) \% 2^{16}$                    | Ramp size depends on test injection point     |
| 1110                          | Continuous/repeat user test | Register 0x0551 to Register 0x0558 | User Pattern 1 to User Pattern 4, then repeat |
| 1111                          | Single user test            | Register 0x0551 to Register 0x0558 | User Pattern 1 to User Pattern 4, then zeros  |

Table 41. JESD204B Sample Input for M = 2, S = 2, N' = 16 (Register 0x0573, Bits[5:4] = 'b00)

| Frame Number | Converter Number | Sample Number | Alternating Checkerboard | 1/0 Word Toggle | Ramp              | PN9    | PN23   | User Repeat | User Single |
|--------------|------------------|---------------|--------------------------|-----------------|-------------------|--------|--------|-------------|-------------|
| 0            | 0                | 0             | 0x5555                   | 0x0000          | $(x) \% 2^{16}$   | 0x496F | 0xFF5C | UP1[15:0]   | UP1[15:0]   |
| 0            | 0                | 1             | 0x5555                   | 0x0000          | $(x) \% 2^{16}$   | 0x496F | 0xFF5C | UP1[15:0]   | UP1[15:0]   |
| 0            | 1                | 0             | 0x5555                   | 0x0000          | $(x) \% 2^{16}$   | 0x496F | 0xFF5C | UP1[15:0]   | UP1[15:0]   |
| 0            | 1                | 1             | 0x5555                   | 0x0000          | $(x) \% 2^{16}$   | 0x496F | 0xFF5C | UP1[15:0]   | UP1[15:0]   |
| 1            | 0                | 0             | 0xAAAA                   | 0xFFFF          | $(x+1) \% 2^{16}$ | 0xC9A9 | 0x0029 | UP2[15:0]   | UP2[15:0]   |
| 1            | 0                | 1             | 0xAAAA                   | 0xFFFF          | $(x+1) \% 2^{16}$ | 0xC9A9 | 0x0029 | UP2[15:0]   | UP2[15:0]   |
| 1            | 1                | 0             | 0xAAAA                   | 0xFFFF          | $(x+1) \% 2^{16}$ | 0xC9A9 | 0x0029 | UP2[15:0]   | UP2[15:0]   |
| 1            | 1                | 1             | 0xAAAA                   | 0xFFFF          | $(x+1) \% 2^{16}$ | 0xC9A9 | 0x0029 | UP2[15:0]   | UP2[15:0]   |
| 2            | 0                | 0             | 0x5555                   | 0x0000          | $(x+2) \% 2^{16}$ | 0x980C | 0xB80A | UP3[15:0]   | UP3[15:0]   |
| 2            | 0                | 1             | 0x5555                   | 0x0000          | $(x+2) \% 2^{16}$ | 0x980C | 0xB80A | UP3[15:0]   | UP3[15:0]   |
| 2            | 1                | 0             | 0x5555                   | 0x0000          | $(x+2) \% 2^{16}$ | 0x980C | 0xB80A | UP3[15:0]   | UP3[15:0]   |
| 2            | 1                | 1             | 0x5555                   | 0x0000          | $(x+2) \% 2^{16}$ | 0x980C | 0xB80A | UP3[15:0]   | UP3[15:0]   |
| 3            | 0                | 0             | 0xAAAA                   | 0xFFFF          | $(x+3) \% 2^{16}$ | 0x651A | 0x3D72 | UP4[15:0]   | UP4[15:0]   |
| 3            | 0                | 1             | 0xAAAA                   | 0xFFFF          | $(x+3) \% 2^{16}$ | 0x651A | 0x3D72 | UP4[15:0]   | UP4[15:0]   |
| 3            | 1                | 0             | 0xAAAA                   | 0xFFFF          | $(x+3) \% 2^{16}$ | 0x651A | 0x3D72 | UP4[15:0]   | UP4[15:0]   |
| 3            | 1                | 1             | 0xAAAA                   | 0xFFFF          | $(x+3) \% 2^{16}$ | 0x651A | 0x3D72 | UP4[15:0]   | UP4[15:0]   |
| 4            | 0                | 0             | 0x5555                   | 0x0000          | $(x+4) \% 2^{16}$ | 0x5FD1 | 0x9B26 | UP1[15:0]   | 0x0000      |
| 4            | 0                | 1             | 0x5555                   | 0x0000          | $(x+4) \% 2^{16}$ | 0x5FD1 | 0x9B26 | UP1[15:0]   | 0x0000      |
| 4            | 1                | 0             | 0x5555                   | 0x0000          | $(x+4) \% 2^{16}$ | 0x5FD1 | 0x9B26 | UP1[15:0]   | 0x0000      |
| 4            | 1                | 1             | 0x5555                   | 0x0000          | $(x+4) \% 2^{16}$ | 0x5FD1 | 0x9B26 | UP1[15:0]   | 0x0000      |

Table 42. Physical Layer 10-Bit Input (Register 0x0573, Bits[5:4] = 'b01)

| 10-Bit Symbol Number | Alternating Checkerboard | 1/0 Word Toggle | Ramp                 | PN9   | PN23  | User Repeat | User Single |
|----------------------|--------------------------|-----------------|----------------------|-------|-------|-------------|-------------|
| 0                    | 0x155                    | 0x000           | $(x) \% 2^{10}$      | 0x125 | 0x3FD | UP1[15:6]   | UP1[15:6]   |
| 1                    | 0x2AA                    | 0x3FF           | $(x + 1) \% 2^{10}$  | 0x2FC | 0x1C0 | UP2[15:6]   | UP2[15:6]   |
| 2                    | 0x155                    | 0x000           | $(x + 2) \% 2^{10}$  | 0x26A | 0x00A | UP3[15:6]   | UP3[15:6]   |
| 3                    | 0x2AA                    | 0x3FF           | $(x + 3) \% 2^{10}$  | 0x198 | 0x1B8 | UP4[15:6]   | UP4[15:6]   |
| 4                    | 0x155                    | 0x000           | $(x + 4) \% 2^{10}$  | 0x031 | 0x028 | UP1[15:6]   | 0x000       |
| 5                    | 0x2AA                    | 0x3FF           | $(x + 5) \% 2^{10}$  | 0x251 | 0x3D7 | UP2[15:6]   | 0x000       |
| 6                    | 0x155                    | 0x000           | $(x + 6) \% 2^{10}$  | 0x297 | 0x0A6 | UP3[15:6]   | 0x000       |
| 7                    | 0x2AA                    | 0x3FF           | $(x + 7) \% 2^{10}$  | 0x3D1 | 0x326 | UP4[15:6]   | 0x000       |
| 8                    | 0x155                    | 0x000           | $(x + 8) \% 2^{10}$  | 0x18E | 0x10F | UP1[15:6]   | 0x000       |
| 9                    | 0x2AA                    | 0x3FF           | $(x + 9) \% 2^{10}$  | 0x2CB | 0x3FD | UP2[15:6]   | 0x000       |
| 10                   | 0x155                    | 0x000           | $(x + 10) \% 2^{10}$ | 0x0F1 | 0x31E | UP3[15:6]   | 0x000       |
| 11                   | 0x2AA                    | 0x3FF           | $(x + 11) \% 2^{10}$ | 0x3DD | 0x008 | UP4[15:6]   | 0x000       |

Table 43. Scrambler 8-bit Input (Register 0x0573, Bits[5:4] = 'b10)

| 8-Bit Octet Number | Alternating Checkerboard | 1/0 Word Toggle | Ramp              | PN9  | PN23 | User Repeat | User Single |
|--------------------|--------------------------|-----------------|-------------------|------|------|-------------|-------------|
| 0                  | 0x55                     | 0x00            | $(x) \% 2^8$      | 0x49 | 0xFF | UP1[15:9]   | UP1[15:9]   |
| 1                  | 0xAA                     | 0xFF            | $(x + 1) \% 2^8$  | 0x6F | 0x5C | UP2[15:9]   | UP2[15:9]   |
| 2                  | 0x55                     | 0x00            | $(x + 2) \% 2^8$  | 0xC9 | 0x00 | UP3[15:9]   | UP3[15:9]   |
| 3                  | 0xAA                     | 0xFF            | $(x + 3) \% 2^8$  | 0xA9 | 0x29 | UP4[15:9]   | UP4[15:9]   |
| 4                  | 0x55                     | 0x00            | $(x + 4) \% 2^8$  | 0x98 | 0xB8 | UP1[15:9]   | 0x00        |
| 5                  | 0xAA                     | 0xFF            | $(x + 5) \% 2^8$  | 0x0C | 0x0A | UP2[15:9]   | 0x00        |
| 6                  | 0x55                     | 0x00            | $(x + 6) \% 2^8$  | 0x65 | 0x3D | UP3[15:9]   | 0x00        |
| 7                  | 0xAA                     | 0xFF            | $(x + 7) \% 2^8$  | 0x1A | 0x72 | UP4[15:9]   | 0x00        |
| 8                  | 0x55                     | 0x00            | $(x + 8) \% 2^8$  | 0x5F | 0x9B | UP1[15:9]   | 0x00        |
| 9                  | 0xAA                     | 0xFF            | $(x + 9) \% 2^8$  | 0xD1 | 0x26 | UP2[15:9]   | 0x00        |
| 10                 | 0x55                     | 0x00            | $(x + 10) \% 2^8$ | 0x63 | 0x43 | UP3[15:9]   | 0x00        |
| 11                 | 0xAA                     | 0xFF            | $(x + 11) \% 2^8$ | 0xAC | 0xFF | UP4[15:9]   | 0x00        |

### Data Link Layer Test Modes

The data link layer test modes are implemented in the [AD9208](#) as defined by Section 5.3.3.8.2 in the JEDEC JESD204B Specification. These tests are shown in Register 0x0574,

Bits[2:0]. Test patterns inserted at this point are useful for verifying the functionality of the data link layer. When the data link layer test modes are enabled, disable SYNCINB± by writing 0xC0 to Register 0x0572.

## SERIAL PORT INTERFACE

The AD9208 SPI allows the user to configure the converter for specific functions or operations through a structured register space provided inside the ADC. The SPI gives the user added flexibility and customization, depending on the application. Addresses are accessed via the serial port and can be written to or read from via the port. Memory is organized into bytes that can be further divided into fields. These fields are documented in the Memory Map section. For detailed operational information, see the [Serial Control Interface Standard \(Rev. 1.0\)](#).

### CONFIGURATION USING THE SPI

Three pins define the SPI of the AD9208 ADC: the SCLK pin, the SDIO pin, and the CSB pin (see Table 44). The SCLK (serial clock) pin synchronizes the read and write data presented from/to the ADC. The SDIO (serial data input/output) pin is a dual-purpose pin that allows data to be sent and read from the internal ADC memory map registers. The CSB (chip select bar) pin is an active low control that enables or disables the read and write cycles.

**Table 44. SPI Pins**

| Pin  | Function  |
|------|---|
| SCLK | Serial clock. The serial shift clock input that is used to synchronize serial interface, reads, and writes.   |
| SDIO | Serial data input/output. A dual-purpose pin that typically serves as an input or an output, depending on the instruction being sent and the relative position in the timing frame. |
| CSB  | Chip select bar. An active low control that gates the read and write cycles.  |

The falling edge of CSB, in conjunction with the rising edge of SCLK, determines the start of the framing. An example of the serial timing and its definitions can be found in Figure 4 and Table 5.

Other modes involving the CSB pin are available. The CSB pin can be held low indefinitely, which permanently enables the device; this is called streaming. The CSB can stall high between bytes to allow additional external timing. When CSB is tied high, SPI functions are placed in a high impedance mode. This mode turns on any SPI pin secondary functions.

All data is composed of 8-bit words. The first bit of each individual byte of serial data indicates whether a read or write

command is issued, which allows the SDIO pin to change direction from an input to an output.

In addition to word length, the instruction phase determines whether the serial frame is a read or write operation, allowing the serial port to be used both to program the chip and to read the contents of the on-chip memory. If the instruction is a readback operation, performing a readback causes the SDIO pin to change direction from an input to an output at the appropriate point in the serial frame.

Data can be sent in MSB first mode or in LSB first mode. MSB first is the default on power-up and can be changed via the SPI port configuration register. For more information about this and other features, see the [Serial Control Interface Standard \(Rev. 1.0\)](#).

### HARDWARE INTERFACE

The pins described in Table 44 comprise the physical interface between the user programming device and the serial port of the AD9208. The SCLK pin and the CSB pin function as inputs when using the SPI interface. The SDIO pin is bidirectional, functioning as an input during write phases and as an output during readback.

The SPI interface is flexible enough to be controlled by either FPGAs or microcontrollers. One method for SPI configuration is described in detail in the [AN-812 Application Note, Microcontroller-Based Serial Port Interface \(SPI\) Boot Circuit](#).

Do not activate the SPI port during periods when the full dynamic performance of the converter is required. Because the SCLK signal, the CSB signal, and the SDIO signal are typically asynchronous to the ADC clock, noise from these signals can degrade converter performance. If the on-board SPI bus is used for other devices, it may be necessary to provide buffers between this bus and the AD9208 to prevent these signals from transitioning at the converter inputs during critical sampling periods.

### SPI ACCESSIBLE FEATURES

Table 45 provides a brief description of the general features that are accessible via the SPI. These features are described in detail in the [Serial Control Interface Standard \(Rev. 1.0\)](#). The AD9208 device specific features are described in the Memory Map section.

**Table 45. Features Accessible Using the SPI**

| Feature             | Description  |
|---------------------|--|
| Mode                | Allows the user to set either power-down mode or standby mode.           |
| Clock               | Allows the user to access the clock divider via the SPI.                 |
| DDC                 | Allows the user to set up decimation filters for different applications. |
| Test Input/Output   | Allows the user to set test modes to have known data on output bits.     |
| Output Mode         | Allows the user to set up outputs.                                       |
| SERDES Output Setup | Allows the user to vary SERDES settings such as swing and emphasis.      |

## MEMORY MAP

### READING THE MEMORY MAP REGISTER TABLE

Each row in the memory map register table has eight bit locations. The memory map is divided into the following sections:

- Analog Devices SPI registers (Register 0x0000 to Register 0x000F)
- Clock/SYSREF/chip power-down pin control registers (Register 0x003F to Register 0x0201)
- Fast detect and signal monitor control registers (Register 0x0245 to Register 0x027A)
- DDC function registers (Register 0x0300 to Register 0x03CD)
- Digital outputs and test modes registers (Register 0x0550 to Register 0x05CB)
- Programmable filter control and coefficients registers (Register 0x0DF8 to Register 0x0F7F)
- VREF/analog input control registers (Register 0x18A6 to Register 0x1A4D)

Table 43 (see the Memory Map Register Details section) documents the default hexadecimal value for each hexadecimal address shown. The column with the heading Bit 7 (MSB) is the start of the default hexadecimal value given. For example, Address 0x0561, the output sample mode register, has a hexadecimal default value of 0x01, which means that Bit 0 = 1, and the remaining bits are 0s. This setting is the default output format value, which is twos complement. For more information on this function and others, see Table 43.

### Open and Reserved Locations

All address and bit locations that are not included in Table 43 are not currently supported for this device. Write unused bits of a valid address location with 0s unless the default value is set otherwise. Writing to these locations is required only when part of an address location is unassigned (for example, Address 0x0561). If the entire address location is open (for example, Address 0x0013), do not write to this address location.

### Default Values

After the AD9208 is reset, critical registers are loaded with default values. The default values for the registers are given in the memory map register table, Table 43.

### Logic Levels

An explanation of logic level terminology follows:

- “Bit is set” is synonymous with “bit is set to Logic 1” or “writing Logic 1 for the bit.”
- “Clear a bit” is synonymous with “bit is set to Logic 0” or “writing Logic 0 for the bit.”
- X denotes a don't care bit.

### Channel Specific Registers

Some channel setup functions, such as the buffer control register (Register 0x1A4C), can be programmed to a different value for each channel. In these cases, channel address locations are internally duplicated for each channel. These registers and bits are designated in Table 43 as local. These local registers and bits can be accessed by setting the appropriate Channel A or Channel B bits in Register 0x0008. If both bits are set, the subsequent write affects the registers of both channels. In a read cycle, set only Channel A or Channel B to read one of the two registers. If both bits are set during an SPI read cycle, the device returns the value for Channel A. Registers and bits designated as global in Table 43 affect the entire device and the channel features for which independent settings are not allowed between channels. The settings in Register 0x0005 do not affect the global registers and bits.

### SPI Soft Reset

After issuing a soft reset by programming 0x81 to Register 0x0000, the AD9208 requires 5 ms to recover. When programming the AD9208 for application setup, ensure that an adequate delay is programmed into the firmware after asserting the soft reset and before starting the device setup.

**MEMORY MAP REGISTER DETAILS**

All address locations that are not included in Table 46 are not currently supported for this device and must not be written.

**Table 46. Memory Map Register Details**

| Addr.                        | Name                       | Bits  | Bit Name                            | Settings       | Description   | Reset | Access |
|------------------------------|----------------------------|-------|-------------------------------------|----------------|---|-------|--------|
| Analog Devices SPI Registers |                            |       |                                     |                |   |       |        |
| 0x0000                       | SPI Configuration A        | 7     | Soft reset mirror (self clearing)   | 0<br>1         | Whenever a soft reset is issued, the user must wait 5 ms before writing to any other register. This provides sufficient time for the boot loader to complete.<br>Do nothing.<br>Reset the SPI and registers (self clearing).                      | 0x0   | R/WC   |
|                              |                            | 6     | LSB first mirror                    | 1<br>0         | Least significant bit (LSB) shifted first for all SPI operations.<br>Most significant bit (MSB) shifted first for all SPI operations.   | 0x0   | R/W    |
|                              |                            | 5     | Address ascension mirror            | 0<br>1         | Multibyte SPI operations cause addresses to autodecrement.<br>Multibyte SPI operations cause addresses to autoincrement.  | 0x0   | R/W    |
|                              |                            | [4:3] | Reserved                            |                | Reserved.   | 0x0   | R      |
|                              |                            | 2     | Address ascension                   | 0<br>1         | Multibyte SPI operations cause addresses to auto-decrement.<br>Multibyte SPI operations cause addresses to auto-increment.  | 0x0   | R/W    |
|                              |                            | 1     | LSB first                           | 1<br>0         | LSB shifted first for all SPI operations.<br>MSB shifted first for all SPI operations.  | 0x0   | R/W    |
|                              |                            | 0     | Soft reset (self clearing)          | 0<br>1         | Whenever a soft reset is issued, the user must wait 5 ms before writing to any other register. This provides sufficient time for the boot loader to complete.<br>Do nothing.<br>Reset the SPI and registers (self clearing).                      | 0x0   | R/WC   |
| 0x0001                       | SPI Configuration B        | [7:2] | Reserved                            |                | Reserved.   | 0x0   | R      |
|                              |                            | 1     | Datapath soft reset (self clearing) | 0<br>1         | Normal operation.<br>Datapath soft reset (self clearing).   | 0x0   | R/WC   |
|                              |                            | 0     | Reserved                            |                | Reserved.   | 0x0   | R      |
| 0x0002                       | Chip configuration (local) | [7:2] | Reserved                            |                | Reserved.   | 0x0   | R      |
|                              |                            | [1:0] | Channel power mode                  | 00<br>10<br>11 | Channel power modes.<br>Normal mode (power-up).<br>Standby mode; digital datapath clocks disabled; JESD204B interface enabled.<br>Power-down mode; digital datapath clocks disabled; digital datapath held in reset; JESD204B interface disabled. | 0x0   | R/W    |
| 0x0003                       | Chip type                  | [7:0] | Chip type                           | 0x3            | Chip type.<br>High speed ADC.   | 0x03  | R      |
| 0x0004                       | Chip ID LSB                | [7:0] | Chip ID LSB [7:0]                   | 0xDF           | Chip ID.<br><a href="#">AD9208</a> .  | 0xE2  | R      |
| 0x0005                       | Chip ID MSB                | [7:0] | Chip ID MSB [15:8]                  |                | Chip ID.  | 0x0   | R      |
| 0x0006                       | Chip grade                 | [7:4] | Chip speed grade                    | 0x0            | Chip speed grade.   | 0x0   | R      |
|                              |                            | [3:0] | Reserved                            |                | Reserved.   | 0x0   | R      |
| 0x0008                       | Device index               | [7:2] | Reserved                            |                | Reserved.   | 0x0   | R      |
|                              |                            | 1     | Channel B                           | 0<br>1         | ADC Core B does not receive the next SPI command.<br>ADC Core B receives the next SPI command.  | 0x1   | R/W    |
|                              |                            | 0     | Channel A                           | 0<br>1         | ADC Core A does not receive the next SPI command.<br>ADC Core A receives the next SPI command.  | 0x1   | R/W    |
| 0x000A                       | Scratch pad                | [7:0] | Scratch pad                         |                | Chip scratch pad register. This register provides a consistent memory location for software debugging.  | 0x0   | R/W    |
| 0x000B                       | SPI revision               | [7:0] | SPI revision                        | 00000001       | SPI revision register. 0x01: Revision 1.0.<br>Revision 1.0.   | 0x1   | R      |

| Addr.  | Name          | Bits  | Bit Name      | Settings | Description  | Reset | Access |
|--------|---------------|-------|---------------|----------|--|-------|--------|
| 0x000C | Vendor ID LSB | [7:0] | Vendor ID LSB |          | Vendor ID [7:0].   | 0x56  | R      |
| 0x000D | Vendor ID MSB | [7:0] | Vendor ID MSB |          | Vendor ID [15:8].  | 0x04  | R      |
| 0x000F | Transfer      | [7:1] | Reserved      |          | Reserved.  | 0x0   | R      |
|        |               | 0     | Chip transfer | 0<br>1   | Self clearing chip transfer bit. This bit is used to update the DDC phase increment and phase offset registers when DDC phase update mode (Register 0x0300, Bit 7) = 1. This makes it possible to synchronously update the DDC mixer frequencies. This bit is also used to update the coefficients for the programmable filter (PFILT).<br>Do nothing. Bit is only cleared after transfer is complete.<br>Self clearing bit used to synchronize the transfer of data from master to slave registers. | 0x0   | R/W    |

## Clock/SYSREF/Chip PDWN Pin Control Registers

|        |                       |       |   |                              |  |     |     |
|--------|-----------------------|-------|---|------------------------------|--|-----|-----|
| 0x003F | Chip PDWN pin (local) | 7     | Local chip PDWN pin disable                   | 0<br>1                       | Function is determined by Register 0x0040, Bits[7:6].<br>Power-down pin (PDWN/STBY) enabled (default).<br>Power-down pin (PDWN/STBY) disabled/ignored.   | 0x0 | R/W |
|        |                       | [6:0] | Reserved                                      |                              | Reserved.  | 0x0 | R   |
| 0x0040 | Chip Pin Control 1    | [7:6] | Global chip PDWN pin functionality            | 00<br>01<br>10               | External power-down pin functionality. Assertion of the external power-down pin (PDWN/STBY) has higher priority than the channel power mode control bits (Register 0x0002, Bits[1:0]). The PDWN/STBY pin is only used when Register 0x0040, Bits[7:6] = 00 or 01.<br>Power-down pin (default). Assertion of external power-down pin (PDWN/STBY) causes the chip to enter full power-down mode.<br>Standby pin. Assertion of external power-down pin (PDWN/STBY) causes the chip to enter standby mode.<br>Pin disabled. Power-down pin (PDWN/STBY) is ignored. | 0x0 | R/W |
|        |                       | [5:3] | Chip FD_B/GPIO_B0 pin functionality           | 000<br>001<br>110<br>111     | Fast Detect B/GPIO B0 pin functionality.<br>Fast Detect B output.<br>JESD204B LMFC output.<br>Pin functionality determined by 0x0041[7:4]<br>Disabled. Configured as input with weak pull-down (default).  | 0x7 | R/W |
|        |                       | [2:0] | Chip FD_A/GPIO_A0 pin functionality           | 000<br>001<br>110<br>111     | Fast Detect A/GPIO A0 pin functionality.<br>Fast Detect A output.<br>JESD204B LMFC output.<br>Pin functionality determined by Register 0x0041, Bits[3:0]<br>Disabled. Configured as an input with weak pull-down (default).  | 0x7 | R/W |
| 0x0041 | Chip Pin Control 2    | [7:4] | Chip FD_B/GPIO_B0 pin secondary functionality | 0000<br>0001<br>1000<br>1001 | Fast Detect B/GPIO B0 pin secondary functionality (only used when Register 0x0040, Bits[5:3] = 110).<br>Chip GPIO B0 input (NCO channel selection).<br>Chip transfer input.<br>Master next trigger output (MNTO).<br>Slave next trigger input (SNTI).  | 0x0 | R/W |
|        |                       | [3:0] | Chip FD_A/GPIO_A0 pin secondary functionality | 0000<br>0001<br>1000<br>1001 | Fast Detect A/GPIO B0 pin secondary functionality (only used when Register 0x0040, Bits[2:0] = 110).<br>Chip GPIO A0 input (NCO channel selection).<br>Chip transfer input.<br>Master next trigger output (MNTO).<br>Slave next trigger input (SNTI).  | 0x0 | R/W |

| Addr.  | Name                             | Bits  | Bit Name                               | Settings                                    | Description   | Reset | Access |
|--------|----------------------------------|-------|--|---|---|-------|--------|
| 0x0042 | Chip Pin Control 3               | [7:4] | Chip GPIO_B1 pin functionality         | 0000<br>1000<br>1001<br>1111                | GPIO B1 pin functionality.<br><br>Chip GPIO B1 input (NCO channel selection).<br>Master next trigger output (MNTO).<br>Slave next trigger input (SNTI).<br>Disabled (configured as input with weak pull-down).  | 0xF   | R/W    |
|        |                                  | [3:0] | Chip GPIO_B1 pin functionality         | 0000<br>1000<br>1001<br>1111                | GPIO A1 pin functionality.<br><br>Chip GPIO A1 input (NCO channel selection).<br>Master next trigger output (MNTO).<br>Slave next trigger input (SNTI).<br>Disabled (configured as input with weak pull-down).  | 0xF   | R/W    |
| 0x0108 | Clock divider control            | [7:3] | Reserved                               |   | Reserved.   | 0x0   | R      |
|        |                                  | [2:0] | Input clock divider (CLK± pins)        | 00<br>01<br>11                              | Divide by 1.<br>Divide by 2.<br>Divide by 4.  | 0x0   | R/W    |
| 0x0109 | Clock divider phase (local)      | [7:4] | Reserved                               |   | Reserved.   | 0x0   | R      |
|        |                                  | [3:0] | Clock divider phase offset             | 0000<br>0001<br>0010<br>...<br>1110<br>1111 | 0 input clock cycles delayed.<br>½ input clock cycles delayed (invert clock).<br>1 input clock cycles delayed.<br>...<br>7 input clock cycles delayed.<br>7½ input clock cycles delayed.  | 0x0   | R/W    |
| 0x010A | Clock divider and SYSREF control | 7     | Clock divider auto phase adjust enable | 0<br>1                                      | Clock divider autophase adjust enable. When enabled, Register 0x0129, Bits[3:0] contain the phase of the divider when SYSREF occurred. The actual divider phase offset = Register 0x0129, Bits[3:0] + Register 0x0109, Bits[3:0].<br>Clock divider phase is not changed by SYSREF (disabled).<br>Clock divider phase is automatically adjusted by SYSREF (enabled).   | 0x0   | R/W    |
|        |                                  | [6:4] | Reserved                               |   | Reserved.   | 0x0   | R      |
|        |                                  | [3:2] | Clock divider negative skew window     | 0<br>1<br>10<br>11                          | Clock divider negative skew window (measured in ½ input device clocks). Number of ½ clock cycles before the input device clock by which captured SYSREF transitions are ignored. Only used when Register 0x010A, Bit 7 = 1. Register 0x010A, Bits[3:2] + Register 0x010A, Bits[1:0] < Register 0x0108, Bits[2:0]. This allows some uncertainty in the sampling of SYSREF without disturbing the input clock divider. Also, SYSREF must be disabled (Register 0x0120, Bits[2:1] = 0x0) when changing this control field.<br>No negative skew; SYSREF must be captured accurately.<br>½ device clock of negative skew.<br>1 device clocks of negative skew.<br>1½ device clocks of negative skew. | 0x0   | R/W    |
|        |                                  | [1:0] | Clock divider positive skew window     | 0<br>1<br>10<br>11                          | Clock divider positive skew window (measured in ½ input device clocks). Number of clock cycles after the input device clock by which captured SYSREF transitions are ignored. Only used when Register 0x010A, Bit 7 = 1. Register 0x010A, Bits[3:2] + Register 0x010A, Bits[1:0] < Register 0x0108, Bits[2:0]. This allows some uncertainty in the sampling of SYSREF without disturbing the input clock divider. Also, SYSREF must be disabled (Register 0x0120, Bits[2:1] = 0x0) when changing this control field.<br>No positive skew; SYSREF must be captured accurately.<br>½ device clock of positive skew.<br>1 device clocks of positive skew.<br>1½ device clocks of positive skew.    | 0x0   | R/W    |

| Addr.  | Name  | Bits  | Bit Name                     | Settings                           | Description   | Reset | Access |
|--------|---|-------|------------------------------|------------------------------------|---|-------|--------|
| 0x010B | Clock divider SYSREF status                   | [7:4] | Reserved                     |                                    | Reserved.   | 0x0   | R      |
|        |   | [3:0] | Clock divider SYSREF offset  |                                    | Clock divider phase status (measured in ½ clock cycles). Internal clock divider phase of the captured SYSREF signal applied to the phase offset. Only used when 0x010A[7] = 1. When Register 0x010A, Bit 7 = 1, Register 0x010A, Bits[3:2] = 0, and Register 0x010A, Bits[1:0] = 0, the clock divider SYSREF offset = Register 0x0129, Bits[3:0].   | 0x0   | R      |
| 0x0110 | Clock delay control                           | [7:3] | Reserved                     |                                    | Reserved.   | 0x0   | R      |
|        |   | [2:0] | Clock delay mode select      | 000<br>010<br>011<br>100<br>110    | Clock delay mode select. Used in conjunction with Register 0x0111 and Register 0x0112.<br>No clock delay.<br>Fine delay: only 0 to 16 delay steps are valid.<br>Fine delay (lowest jitter): only 0 to 16 delay steps are valid.<br>Fine delay: all 192 delay steps are valid.<br>Fine delay enabled (all 192 delay steps are valid); superfine delay enabled (all 128 delay steps are valid). | 0x0   | R/W    |
| 0x0111 | Clock superfine delay (local)                 | [7:0] | Clock superfine delay adjust | 0x00<br>...<br>0x08<br>...<br>0x80 | Clock superfine delay adjust. This is an unsigned control to adjust the superfine sample clock delay in 0.25 ps steps. These bits are only used when Register 0x0110, Bits[2:0] = 010 or 110.<br>0 delay steps.<br>...<br>8 delay steps.<br>...<br>128 delay steps.   | 0x0   | R/W    |
| 0x0112 | Clock fine delay (local)                      | [7:0] | Set clock fine delay         | 0x00<br>...<br>0x08<br>...<br>0xC0 | Clock fine delay adjust. This is an unsigned control to adjust the fine sample clock skew in 1.725 ps steps. These bits are only used when Register 0x0110, Bits[2:0] = 0x2, 0x3, 0x4, or 0x6. Minimum = 0. Maximum = 192. Increment = 1. Unit = delay steps.<br>0 delay steps.<br>...<br>8 delay steps.<br>...<br>192 delay steps.   | 0xC0  | R/W    |
| 0x011B | Clock status                                  | [7:1] | Reserved                     |                                    | Reserved.   | 0x0   | R      |
|        |   | 0     | Input clock detect           | 0<br>1                             | Clock detection status.<br>Input clock not detected.<br>Input clock detected/locked.  | 0x0   | R      |
| 0x011C | Clock Duty Cycle Stabilizer 1 control (local) | [7:2] | Reserved                     |                                    | Reserved  | 0x0   | R/W    |
|        |   | 1     | DCS1 enable                  | 0<br>1                             | Clock DCS1 enable.<br>DCS1 bypassed.<br>DCS1 enabled.   | 0x1   | R/W    |
|        |   | 0     | DCS1 power up                | 0<br>1                             | Clock DCS1 power-up.<br>DCS1 powered down.<br>DCS1 powered up.  | 0x1   | R/W    |
| 0x011E | Clock Duty Cycle Stabilizer 2 control         | [7:2] | Reserved                     |                                    | Reserved.   | 0x0   | R/W    |
|        |   | 1     | DCS2 enable                  | 0<br>1                             | Clock DCS2 enable.<br>DCS2 bypassed.<br>DCS2 enabled.   | 0x1   | R/W    |
|        |   | 0     | DCS2 power up                | 0<br>1                             | Clock DCS2 power-up.<br>DCS2 powered down.<br>DCS2 powered up.  | 0x1   | R/W    |



| Addr.    | Name  | Bits         | Bit Name   | Settings | Description  | Reset | Access |
|----------|---|--------------|--|----------|--|-------|--------|
| 0x0120   | SYSREF Control 1                                      | 7            | Reserved   |          | Reserved.  | 0x0   | R      |
|          |   | 6            | SYSREF± flag reset   | 0        | Normal flag operation.   | 0x0   | R/W    |
|          |   |              |  | 1        | SYSREF flags held in reset (setup and hold error flags cleared).   |       |        |
|          |   | 5            | Reserved   |          | Reserved.  | 0x0   | R      |
|          |   | 4            | SYSREF± transition select  | 0        | SYSREF is valid on low to high transitions using the selected CLK± edge. When changing this setting, SYSREF± mode select must be set to disabled.  | 0x0   | R/W    |
|          |   |              |  | 1        | SYSREF is valid on high to low transitions using the selected CLK± edge. When changing this setting, SYSREF± mode select must be set to disabled.  |       |        |
|          |   | 3            | CLK± edge select   | 0        | Captured on the rising edge of CLK± input.   | 0x0   | R/W    |
|          |   |              |  | 1        | Captured on the falling edge of CLK± input.  |       |        |
| [2:1]    | SYSREF± mode select                                   | 0<br>1<br>10 | Disabled.<br>Continuous.<br>N-shot.  | 0x0      | R/W  |       |        |
| 0        | Reserved  |              | Reserved.  | 0x0      | R  |       |        |
| 0x0121   | SYSREF Control 2                                      | [7:4]        | Reserved   |          | Reserved.  | 0x0   | R      |
|          |   | [3:0]        | SYSREF N-shot ignore counter select  | 0000     | Next SYSREF only (do not ignore).  | 0x0   | R/W    |
|          |   |              |  | 0001     | Ignore the first SYSREF± transition.   |       |        |
| 0010     | Ignore the first two SYSREF± transitions.             |              |  |          |  |       |        |
| 0011     | Ignore the first three SYSREF± transitions.           |              |  |          |  |       |        |
| ...      | ...   |              |  |          |  |       |        |
| 1110     | Ignore the first 14 SYSREF± transitions.              |              |  |          |  |       |        |
| 1111     | Ignore the first 15 SYSREF± transitions.              |              |  |          |  |       |        |
| 0x0122   | SYSREF Control 3                                      | [7:4]        | Reserved   |          | Reserved.  | 0x0   | R      |
|          |   | [3:2]        | SYSREF window negative   |          | Negative skew window (measured in sample clocks). Number of clock cycles before the sample clock by which captured SYSREF transitions are ignored. | 0x0   | R/W    |
|          |   |              |  | 00       | No negative skew; SYSREF must be captured accurately.  |       |        |
|          |   |              |  | 01       | One sample clock of negative skew.   |       |        |
|          |   |              |  | 10       | Two sample clocks of negative skew.  |       |        |
| 11       | Three sample clocks of negative skew.                 |              |  |          |  |       |        |
| [1:0]    | SYSREF window positive                                |              | Positive skew window (measured in sample clocks). Number of clock cycles before the sample clock by which captured SYSREF transitions are ignored. | 0x0      | R/W  |       |        |
| 00       | No positive skew; SYSREF must be captured accurately. |              |  |          |  |       |        |
| 01       | One sample clock of positive skew.                    |              |  |          |  |       |        |
| 10       | Two sample clocks of positive skew.                   |              |  |          |  |       |        |
| 11       | Three sample clocks of positive skew.                 |              |  |          |  |       |        |
| 0x0123   | SYSREF Control 4                                      | 7            | Reserved   |          | Reserved.  | 0x0   | R      |
|          |   | [6:0]        | SYSREF± timestamp delay, Bits[6:0]   |          | SYSREF timestamp delay (in converter sample clock cycles).   | 0x00  | R/W    |
|          |   |              |  | 0        | 0 sample clock cycle delay.  |       |        |
|          |   |              |  | 1        | 1 sample clock cycle delay.  |       |        |
| ...      | ...   |              |  |          |  |       |        |
| 111 1111 | 127 sample clock cycle delay.                         |              |  |          |  |       |        |
| 0x0128   | SYSREF Status 1                                       | [7:4]        | SYSREF± hold status  |          | SYSREF hold status.  | 0x0   | R      |
|          |   | [3:0]        | SYSREF± setup status   |          | SYSREF setup status.   | 0x0   | R      |

| Addr.                                 | Name                  | Bits  | Bit Name  | Settings   | Description   | Reset | Access |
|---------------------------------------|-----------------------|-------|---|--|---|-------|--------|
| 0x0129                                | SYSREF Status 2       | [7:4] | Reserved  |  | Reserved.   | 0x0   | R      |
|                                       |                       | [3:0] | Clock divider phase when SYSREF± was captured                   | 0000<br>0001<br>0010<br>0011<br>0100<br>...<br>1111  | SYSREF divider phase. Represents the phase of the divider when SYSREF was captured.<br><br>In phase.<br>SYSREF± is ½ cycle delayed from clock.<br>SYSREF± is 1 cycle delayed from clock.<br>SYSREF± is 1½ input clock cycles delayed.<br>SYSREF± is 2 input clock cycles delayed.<br>...<br>SYSREF± is 7½ input clock cycles delayed.   | 0x0   | R      |
| 0x012A                                | SYSREF Status 3       | [7:0] | SYSREF counter, Bits[7:0] increments when a SYSREF± is captured |  | SYSREF count. Running counter that increments whenever a SYSREF event is captured. Reset by Register 0x120, Bit 6. Wraps around at 255. Read these bits only when Register 0x120, Bits[2:1] are set to disabled.  | 0x0   | R      |
| 0x01FF                                | Chip sync mode        | [7:1] | Reserved  |  | Reserved.   | 0x0   | R      |
|                                       |                       | 0     | Synchronization mode  | 0<br><br>1   | JESD204B synchronization mode. The SYSREF signal resets all internal clock dividers. Use this mode when synchronizing multiple chips as specified in the JESD204B standard. If the phase of any of the dividers must change, the JESD204B link goes down.<br><br>Timestamp mode. The SYSREF signal does not reset internal clock dividers. In this mode, the JESD204B link and the signal monitor are not affected by the SYSREF signal. The SYSREF signal timestamps a sample as it passes through the ADC and is used as a control bit in the JESD204B output word. | 0x0   | R/W    |
| Chip Operating Mode Control Registers |                       |       |   |  |   |       |        |
| 0x0200                                | Chip mode             | [7:6] | Reserved  |  | Reserved.   | 0x0   | R/W    |
|                                       |                       | 5     | Chip Q ignore   | 0<br>1   | Chip real (I) only selection.<br>Both real (I) and complex (Q) selected.<br>Only real (I) selected; complex (Q) is ignored.   | 0x0   | R/W    |
|                                       |                       | 4     | Reserved  |  | Reserved.   | 0x0   | R      |
|                                       |                       | [3:0] | Chip application mode   | 0000<br>0001<br>0010<br>0011   | Full bandwidth mode (default).<br>One DDC mode (DDC0 only)<br>Two DDC mode (DDC0 and DDC1 only)<br>Four DDC mode (DDC0, DDC1, DDC2, and DDC3)   | 0x0   | R/W    |
| 0x0201                                | Chip decimation ratio | [7:4] | Reserved  |  | Reserved.   | 0x0   | R      |
|                                       |                       | [3:0] | Chip decimation ratio   | 0000<br>0001<br>1000<br>0010<br>0101<br>1001<br>0011<br>0110<br>1010<br>0111<br>0100<br>1101<br>1011<br>1110<br>1111<br>1100 | Chip decimation ratio.<br>Full sample rate (decimate by 1, DDCs are bypassed).<br>Decimate by 2.<br>Decimate by 3.<br>Decimate by 4.<br>Decimate by 5.<br>Decimate by 6.<br>Decimate by 8.<br>Decimate by 10.<br>Decimate by 12.<br>Decimate by 15.<br>Decimate by 16.<br>Decimate by 20.<br>Decimate by 24.<br>Decimate by 30.<br>Decimate by 40.<br>Decimate by 48.   | 0x0   | R/W    |

| Addr.  | Name                            | Bits  | Bit Name                                 | Settings | Description   | Reset | Access |
|--|---------------------------------|-------|--|----------|---|-------|--------|
| Fast Detect and Signal Monitor Control Registers |                                 |       |  |          |   |       |        |
| 0x0245   | Fast detect control (local)     | [7:4] | Reserved                                 |          | Reserved.   | 0x0   | R      |
|  |                                 | 3     | Force FD_A/FD_B pins                     | 0<br>1   | Normal operation of the fast detect pin.<br>Force a value on the fast detect pin (see Bit 2).   | 0x0   | R/W    |
|  |                                 | 2     | Force value of FD_A/FD_B pins            |          | The fast detect output pin for this channel is set to this value when the output is forced.   | 0x0   | R/W    |
|  |                                 | 1     | Reserved                                 |          | Reserved.   | 0x0   | R      |
|  |                                 | 0     | Enable fast detect output                | 0<br>1   | Fast detect disabled.<br>Fast detect enabled.   | 0x0   | R/W    |
| 0x0247   | Fast detect up LSB (local)      | [7:0] | Fast detect upper threshold              |          | LSBs of the fast detect upper threshold. This register contains the 8 LSBs of the programmable 13-bit upper threshold that is compared to the fine ADC magnitude.   | 0x0   | R/W    |
| 0x0248   | Fast detect up MSB (local)      | [7:5] | Reserved                                 |          | Reserved.   | 0x0   | R      |
|  |                                 | [4:0] | Fast detect upper threshold              |          | MSBs of the fast detect upper threshold. This register contains the 8 LSBs of the programmable 13-bit upper threshold that is compared to the fine ADC magnitude.   | 0x0   | R/W    |
| 0x0249   | Fast detect low LSB (local)     | [7:0] | Fast detect lower threshold              |          | LSBs of the fast detect lower threshold. This register contains the 8 LSBs of the programmable 13-bit lower threshold that is compared to the fine ADC magnitude.   | 0x0   | R/W    |
| 0x024A   | Fast detect low MSB (local)     | [7:5] | Reserved                                 |          | Reserved.   | 0x0   | R      |
|  |                                 | [4:0] | Fast detect lower threshold              |          | MSBs of the fast detect lower threshold. This register contains the 8 LSBs of the programmable 13-bit lower threshold that is compared to the fine ADC magnitude  | 0x0   | R/W    |
| 0x024B   | Fast detect dwell LSB (local)   | [7:0] | Fast detect dwell time                   |          | LSBs of the fast detect dwell time counter target. This is a load value for a 16-bit counter that determines how long the ADC data must remain below the lower threshold before the FD_x pins are reset to 0.   | 0x0   | R/W    |
| 0x024C   | Fast detect dwell MSB (local)   | [7:0] | Fast detect dwell time                   |          | MSBs of the fast detect dwell time counter target. This is a load value for a 16-bit counter that determines how long the ADC data must remain below the lower threshold before the FD_x pins are reset to 0.   | 0x0   | R/W    |
| 0x026F   | Signal monitor sync control     | [7:2] | Reserved                                 |          | Reserved.   | 0x0   | R      |
|  |                                 | 1     | Signal monitor next synchronization mode | 0<br>1   | Signal monitor next synchronization mode.<br><br>Continuous mode.<br>Next synchronization mode. Only the next valid edge of the SYSREF± pin is used to synchronize the signal monitor block. Subsequent edges of the SYSREF± pin are ignored. When the next SYSREF is found, Register 0x026F, Bit 0 clears. The SYSREF± pin must be an integer multiple of the signal monitor period for this function to operate correctly in continuous mode. | 0x0   | R/W    |
|  |                                 | 0     | Signal monitor synchronization mode      | 0<br>1   | Signal monitor synchronization enable<br><br>Synchronization disabled.<br>If Register 0x026F, Bit 1 = 1, only the next valid edge of the SYSREF± pin is used to synchronize the signal monitor block. Subsequent edges of the SYSREF± pin are ignored. When the next SYSREF signal is received, this bit is cleared. The SYSREF± input pin must be enabled to synchronize the signal monitor blocks.  | 0x0   | R/W    |
| 0x0270   | Signal monitor control (local)  | [7:2] | Reserved                                 |          | Reserved.   | 0x0   | R      |
|  |                                 | 1     | Peak detector                            | 0<br>1   | Peak detector disabled.<br>Peak detector enabled.   | 0x0   | R/W    |
|  |                                 | 0     | Reserved                                 |          | Reserved.   | 0x0   | R      |
| 0x0271   | Signal Monitor Period 0 (local) | [7:0] | Signal monitor period [7:0]              |          | Bits[7:0] of the 24-bit value that sets the number of output clock cycles over which the signal monitor performs its operation. Only even values are supported.   | 0x80  | R/W    |

| Addr.  | Name   | Bits  | Bit Name                                  | Settings | Description   | Reset | Access |
|--------|--|-------|---|----------|---|-------|--------|
| 0x0272 | Signal Monitor Period 1 (local)              | [7:0] | Signal monitor period [15:8]              |          | Bits[15:8] of the 24-bit value that sets the number of output clock cycles over which the signal monitor performs its operation. Only even values are supported.  | 0x0   | R/W    |
| 0x0273 | Signal Monitor Period 2 (local)              | [7:0] | Signal monitor period [23:16]             |          | Bits[23:16] of the 24-bit value that sets the number of output clock cycles over which the signal monitor performs its operation. Only even values are supported.   | 0x0   | R/W    |
| 0x0274 | Signal monitor status control (local)        | [7:5] | Reserved                                  |          | Reserved.   | 0x0   | R      |
|        |  | 4     | Result update                             | 1        | Update signal monitor status registers, Register 0x0275 to Register 0x0278. Self clearing.  | 0x0   | R/WC   |
|        |  | 3     | Reserved                                  |          | Reserved.   | 0x0   | R      |
|        |  | [2:0] | Result selection                          | 001      | Peak detector placed on status readback signals.  | 0x1   | R/W    |
| 0x0275 | Signal Monitor Status 0 (local)              | [7:0] | Signal monitor result [7:0]               |          | Signal monitor status result. This 20-bit value contains the status result calculated by the signal monitor block.  | 0x0   | R      |
| 0x0276 | Signal Monitor Status 1 (local)              | [7:0] | Signal monitor result [15:8]              |          | Signal monitor status result.   | 0x0   | R      |
| 0x0277 | Signal Monitor Status 2 (local)              | [7:4] | Reserved                                  |          | Reserved.   | 0x0   | R      |
|        |  | [3:0] | Signal monitor result [19:16]             |          | Signal monitor status result.   | 0x0   | R      |
| 0x0278 | Signal monitor status frame counter (local)  | [7:0] | Period count result, Bits[7:0]            |          | Signal monitor frame counter status bits. Frame counter increments whenever the period counter expires.   | 0x0   | R      |
| 0x0279 | Signal monitor serial framer control (local) | [7:2] | Reserved                                  |          | Reserved.   | 0x0   | R      |
|        |  | [1:0] | Signal monitor SPORT over JESD204B enable | 00<br>11 | Disabled.<br>Enabled.   | 0x0   | R/W    |
| 0x027A | SPORT over JESD204B input selection (local)  | [7:6] | Reserved                                  |          | Reserved.   | 0x0   | R      |
|        |  | 1     | SPORT over JESD204B input selection       | 0<br>1   | Signal monitor serial framer input selection. When each individual bit is a 1, the corresponding signal statistics information is sent within the frame.<br>Disabled.<br>Peak detector data inserted in the serial frame. | 0x1   | R/W    |
|        |  | 0     | Reserved                                  |          | Reserved.   | 0x0   | R      |

## DDC Function Registers (See the Digital Downconverter (DDC) Section)

|        |                  |       |                                 |        |   |     |     |
|--------|------------------|-------|---------------------------------|--------|---|-----|-----|
| 0x0300 | DDC SYNC control | 7     | DDC FTW/POW/MAW/MBW update mode | 0<br>1 | Select DDC FTW/POW/MAW/MBW update mode.<br><br>Instantaneous/continuous update. FTW/POW/MAW/MBW values are updated immediately.<br>FTW/POW/MAW/MBW values are updated synchronously when the chip transfer bit (Register 0x000F, Bit 0) is set. | 0x0 | R/W |
|        |                  | [6:5] | Reserved                        |        | Reserved.   | 0x0 | R   |
|        |                  | 4     | DDC NCO soft reset              | 0<br>1 | This bit can be used to synchronize all the NCOs inside the DDC blocks.<br>Normal operation.<br>DDC held in reset.  | 0x0 | R/W |
|        |                  | [3:2] | Reserved                        |        | Reserved.   | 0x0 | R   |

| Addr.  | Name         | Bits  | Bit Name                              | Settings   | Description   | Reset | Access |
|--------|--------------|-------|---------------------------------------|--|---|-------|--------|
|        |              | 1     | DDC next synchronization              | 0<br>1   | Continuous mode. The SYSREF frequency must be an integer multiple of the NCO frequency for this function to operate correctly in continuous mode.<br>Only the next valid edge of the SYSREF± pin is used to synchronize the NCO in the DDC block. Subsequent edges of the SYSREF± pin are ignored. When the next SYSREF signal is found, the DDC synchronization enable bit (Register 0x0300, Bit 0) is cleared.  | 0x0   | R/W    |
|        |              | 0     | DDC synchronization mode              | 0<br>1   | The SYSREF input pin must be enabled to synchronize the DDCs.<br>Synchronization disabled.<br>If DDC next synchronization (Register 0x0300, Bit 1 = 1), only the next valid edge of the SYSREF± pin is used to synchronize the NCO in the DDC block. Subsequent edges of the SYSREF± pin are ignored. When the next SYSREF signal is received, this bit is cleared.   | 0x0   | R/W    |
| 0x0310 | DDC0 control | 7     | DDC0 mixer select                     | 0<br>1   | Real mixer (I and Q inputs must be from the same real channel).<br>Complex mixer (I and Q must be from separate, real and imaginary quadrature ADC receive channels; analog demodulator).   | 0x0   | R/W    |
|        |              | 6     | DDC0 gain select                      | 0<br>1   | Gain can be used to compensate for the 6 dB loss associated with mixing an input signal down to baseband and filtering out its negative component.<br>0 dB gain.<br>6 dB gain (multiply by 2).  | 0x0   | R/W    |
|        |              | [5:4] | DDC0 intermediate frequency (IF) mode | 00<br>01<br>10<br>11                                 | Variable IF mode.<br>0 Hz IF mode.<br>f <sub>s</sub> Hz IF mode.<br>Test mode.  | 0x0   | R/W    |
|        |              | 3     | DDC0 complex to real enable           | 0<br>1   | Complex (I and Q) outputs contain valid data.<br>Real (I) output only. complex to real enabled. Uses extra f <sub>s</sub> mixing to convert to real.  | 0x0   | R/W    |
|        |              | [2:0] | DDC0 decimation rate select           | 000<br>001<br>010<br>011<br>100<br>101<br>110<br>111 | Decimation filter selection.<br>HB1 + HB2 filter selection: decimate by 2 (complex to real enabled), or decimate by 4 (complex to real disabled).<br>HB1 + HB2 + HB3 filter selection: decimate by 4 (complex to real enabled), or decimate by 8 (complex to real disabled).<br>HB1 + HB2 + HB3 + HB4 filter selection: decimate by 8 (complex to real enabled), or decimate by 16 (complex to real disabled).<br>HB1 filter selection: decimate by 1 (complex to real enabled), or decimate by 2 (complex to real disabled).<br>HB1 + TB2 filter selection: decimate by 3 (complex to real enabled), or decimate by 6 (complex to real disabled).<br>HB1 + HB2 + TB2 filter selection: decimate by 6 (complex to real enabled), or decimate by 12 (complex to real disabled).<br>HB1 + HB2 + HB3 + TB2 filter selection: decimate by 12 (complex to real enabled), or decimate by 24 (complex to real disabled).<br>Decimation determined by Register 0x0311, Bits[7:4]. | 0x0   | R/W    |

| Addr.  | Name              | Bits  | Bit Name                             | Settings   | Description   | Reset | Access |
|--------|-------------------|-------|--------------------------------------|------------|---|-------|--------|
| 0x0311 | DDC0 input select | [7:4] | DDC0 decimation rate select          |            | Only valid when Register 0x0310, Bits[2:0] = 3'b111.  | 0x0   | R/W    |
|        |                   |       |                                      | 0          | TB2 + HB4 + HB3 + HB2 + HB1 filter selection: decimate by 48 (complex to real disabled), or decimate by 24 (complex to real enabled). |       |        |
|        |                   |       |                                      | 10         | FB2 + HB1 filter selection: decimate by 10 (complex to real disabled), or decimate by 5 (complex to real enabled).                    |       |        |
|        |                   |       |                                      | 11         | FB2 + HB2 + HB1 filter selection: decimate by 20 (complex to real disabled), or decimate by 10 (complex to real enabled).             |       |        |
|        |                   |       |                                      | 100        | FB2 + HB3 + HB2 + HB1 filter selection: decimate by 40 (complex to real disabled), or decimate by 20 (complex to real enabled).       |       |        |
|        |                   |       |                                      | 111        | TB1 filter selection: decimate by 3 (decimate by 1.5 not supported).  |       |        |
|        |                   |       |                                      | 1000       | FB2 + TB1 filter selection: decimate by 15 (decimate by 7.5 not supported).   |       |        |
|        |                   |       |                                      | 1001       | HB2 + FB2 + TB1 filter selection: decimate by 30 (decimate by 15 not supported).  |       |        |
|        |                   | 3     | Reserved                             |            | Reserved.   | 0x0   | R      |
|        |                   | 2     | DDC0 Q input select                  |            |   | 0x0   | R/W    |
|        | 0                 |       |                                      | Channel A. |   |       |        |
|        |                   |       |                                      | 1          | Channel B.  |       |        |
|        |                   | 1     | Reserved                             |            | Reserved.   | 0x0   | R      |
|        |                   | 0     | DDC0 I input select                  |            |   | 0x0   | R/W    |
|        |                   |       |                                      | 0          | Channel A.  |       |        |
|        |                   |       |                                      | 1          | Channel B.  |       |        |
| 0x0314 | DDC0 NCO control  | [7:4] | DDC0 NCO channel select mode         |            | For edge control, the internal counter wraps after the Register 0x0314, Bits[3:0] value is reached.                                   | 0x0   | R/W    |
|        |                   |       |                                      | 0          | Use Register 0x0314, Bits[3:0].   |       |        |
|        |                   |       |                                      | 1          | 2'b0, GPIO_B0, GPIO_A0.   |       |        |
|        |                   |       |                                      | 10         | 2'b0, GPIO_B1, GPIO_A1.   |       |        |
|        |                   |       |                                      | 11         | 2'b00, GPIO_A1, GPIO_A0.  |       |        |
|        |                   |       |                                      | 100        | 2'b00, GPIO_B1, GPIO_B0.  |       |        |
|        |                   |       |                                      | 101        | GPIO_B1, GPIO_A1, GPIO_B0, GPIO_A0.   |       |        |
|        |                   |       |                                      | 110        | GPIO_B1, GPIO_B0, GPIO_A1, GPIO_A0.   |       |        |
|        |                   |       |                                      | 1000       | Increment internal counter on rising edge of the GPIO_A0 pin.   |       |        |
|        |                   |       |                                      | 1001       | Increment internal counter on rising edge of the GPIO_A1 pin.   |       |        |
|        |                   |       |                                      | 1010       | Increment internal counter on rising edge of the GPIO_B0 pin.   |       |        |
|        |                   |       |                                      | 1011       | Increment internal counter on rising edge of the GPIO_B1 pin.   |       |        |
|        |                   | [3:0] | DDC0 NCO register map channel select |            | NCO channel select register map control.  | 0x0   | R/W    |
|        |                   |       |                                      | 0          | Select NCO Channel 0.   |       |        |
|        |                   |       |                                      | 1          | Select NCO Channel 1.   |       |        |
|        |                   |       |                                      | 10         | Select NCO Channel 2.   |       |        |
|        |                   |       |                                      | 11         | Select NCO Channel 3.   |       |        |
|        |                   |       |                                      | 100        | Select NCO Channel 4.   |       |        |
|        |                   |       |                                      | 101        | Select NCO Channel 5.   |       |        |
|        |                   |       |                                      | 110        | Select NCO Channel 6.   |       |        |
|        |                   |       |                                      | 111        | Select NCO Channel 7.   |       |        |
|        |                   |       |                                      | 1000       | Select NCO Channel 8.   |       |        |
|        |                   |       |                                      | 1001       | Select NCO Channel 9.   |       |        |
|        |                   |       |                                      | 1010       | Select NCO Channel 10.  |       |        |
|        |                   |       |                                      | 1011       | Select NCO Channel 11.  |       |        |
|        |                   |       |                                      | 1100       | Select NCO Channel 12.  |       |        |
|        |                   |       |                                      | 1101       | Select NCO Channel 13.  |       |        |
|        |                   |       |                                      | 1110       | Select NCO Channel 14.  |       |        |
|        |                   |       |                                      | 1111       | Select NCO Channel 15.  |       |        |

| Addr.  | Name                        | Bits   | Bit Name  | Settings                     | Description   | Reset | Access |
|--------|-----------------------------|--------|---|------------------------------|---|-------|--------|
| 0x0315 | DDC0 phase control          | [7:4]  | Reserved  |                              | Reserved.   | 0x0   | R      |
|        |                             | [3:0]  | DDC0 phase update index   | 0000<br>0001<br>0010<br>0011 | Indexes the NCO channel whose phase and offset is updated. The update method is based on the DDC phase update mode, which can be continuous or require chip transfer.<br>Update NCO Channel 0.<br>Update NCO Channel 1.<br>Update NCO Channel 2.<br>Update NCO Channel 3. | 0x0   | R/W    |
| 0x0316 | DDC0 Phase Increment 0      | [7:0]  | DDC0 phase increment [7:0]  |                              | FTW. Twos complement phase increment value for the NCO. Complex mixing frequency = $(DDC\ phase\ increment \times f_s)/2^{48}$ .  | 0x0   | R/W    |
| 0x0317 | DDC0 Phase Increment 1      | [7:0]  | DDC0 phase increment [15:8]   |                              | FTW. Twos complement phase increment value for the NCO. Complex mixing frequency = $(DDC\ phase\ increment \times f_s)/2^{48}$ .  | 0x0   | R/W    |
| 0x0318 | DDC0 Phase Increment 2      | [7:0]  | DDC0 phase increment [23:16]  |                              | FTW. Twos complement phase increment value for the NCO. Complex mixing frequency = $(DDC\ phase\ increment \times f_s)/2^{48}$ .  | 0x0   | R/W    |
| 0x0319 | DDC0 Phase Increment 3      | [7:0]  | DDC0 phase increment [31:24]  |                              | FTW. Twos complement phase increment value for the NCO. Complex mixing frequency = $(DDC\ phase\ increment \times f_s)/2^{48}$ .  | 0x0   | R/W    |
| 0x031A | DDC0 Phase Increment 4      | [7:0]  | DDC0 phase increment [39:32]  |                              | FTW. Twos complement phase increment value for the NCO. Complex mixing frequency = $(DDC\ phase\ increment \times f_s)/2^{48}$ .  | 0x0   | R/W    |
| 0x031B | DDC0 Phase Increment 5      | [7:0]  | DDC0 phase increment [47:40]  |                              | FTW. Twos complement phase increment value for the NCO. Complex mixing frequency = $(DDC\ phase\ increment \times f_s)/2^{48}$ .  | 0x0   | R/W    |
| 0x031D | DDC0 Phase Offset 0         | [7:0]  | DDC0 phase offset [7:0]   |                              | Twos complement phase offset value for the NCO.   | 0x0   | R/W    |
| 0x031E | DDC0 Phase Offset 1         | [7:0]  | DDC0 phase offset [15:8]  |                              | Twos complement phase offset value for the NCO.   | 0x0   | R/W    |
| 0x031F | DDC0 Phase Offset 2         | [7:0]  | DDC0 phase offset [23:16]   |                              | Twos complement phase offset value for the NCO.   | 0x0   | R/W    |
| 0x0320 | DDC0 Phase Offset 3         | [7:0]  | DDC0 phase offset [31:24]   |                              | Twos complement phase offset value for the NCO.   | 0x0   | R/W    |
| 0x0321 | DDC0 Phase Offset 4         | [7:0]  | DDC0 phase offset [39:32]   |                              | Twos complement phase offset value for the NCO.   | 0x0   | R/W    |
| 0x0322 | DDC0 Phase Offset 5         | [7:0]  | DDC0 phase offset [47:40]   |                              | Twos complement phase offset value for the NCO.   | 0x0   | R/W    |
| 0x0327 | DDC0 test enable            | [7:3]  | Reserved  |                              | Reserved.   | 0x0   | R      |
|        |                             | 2      | DDC0 Q output test mode enable  | 0<br>1                       | Q samples always use the Test Mode B block. The test mode is selected using the channel dependent Register 0x0550, Bits[3:0].<br>Test mode disabled.<br>Test mode enabled.  | 0x0   | R/W    |
|        |                             | 1      | Reserved  |                              | Reserved.   | 0x0   | R      |
|        |                             | 0      | DDC0 I output test mode enable  | 0<br>1                       | I samples always use the Test Mode A block. The test mode is selected using the channel dependent Register 0x0550, Bits[3:0].<br>Test mode disabled.<br>Test mode enabled.  | 0x0   | R/W    |
| 0x0330 | DDC1 control                | 7      | DDC1 mixer select   | 0                            | Real mixer (I and Q inputs must be from the same real channel). Complex mixer (I and Q must be from separate, real and imaginary quadrature ADC receive channels; analog demodulator).  | 0x0   | R/W    |
|        |                             |        |   | 1                            |   |       |        |
|        |                             | 6      | DDC1 gain select  | 0                            | Gain can be used to compensates for the 6 dB loss associated with mixing an input signal down to baseband and filtering out its negative component.<br>0 dB gain.<br>6 dB gain (multiply by 2).   | 0x0   | R/W    |
|        |                             |        |   | 1                            |   |       |        |
|        |                             | [5:4]  | DDC1 intermediate frequency (IF) mode   | 00<br>01<br>10<br>11         | Variable IF mode.<br>0 Hz IF mode.<br>$f_s$ Hz IF mode.<br>Test mode.   | 0x0   | R/W    |
| 3      | DDC1 complex to real enable | 0<br>1 | Complex (I and Q) outputs contain valid data.<br>Real (I) output only. Complex to real enabled. Uses extra $f_s$ mixing to convert to real. | 0x0                          | R/W   |       |        |

| Addr.  | Name              | Bits  | Bit Name                     | Settings  | Description   | Reset | Access |
|--------|-------------------|-------|------------------------------|---|---|-------|--------|
|        |                   | [2:0] | DDC1 decimation rate select  | 000<br>001<br>010<br>011<br>100<br>101<br>110<br>111                    | Decimation filter selection.<br><br>HB1 + HB2 filter selection: decimate by 2 (complex to real enabled), or decimate by 4 (complex to real disabled).<br>HB1 + HB2 + HB3 filter selection: decimate by 4 (complex to real enabled), or decimate by 8 (complex to real disabled).<br>HB1 + HB2 + HB3 + HB4 filter selection: decimate by 8 (complex to real enabled), or decimate by 16 (complex to real disabled).<br>HB1 filter selection: decimate by 1 (complex to real enabled), or decimate by 2 (complex to real disabled).<br>HB1 + TB2 filter selection: decimate by 3 (complex to real enabled), or decimate by 6 (complex to real disabled).<br>HB1 + HB2 + TB2 filter selection: decimate by 6 (complex to real enabled), or decimate by 12 (complex to real disabled).<br>HB1 + HB2 + HB3 + TB2 filter selection: decimate by 12 (complex to real enabled), or decimate by 24 (complex to real disabled).<br>Decimation determined by Register 0x0331, Bits[7:4]. | 0x0   | R/W    |
| 0x0331 | DDC1 input select | [7:4] | DDC1 decimation rate select  | 0<br>10<br>11<br>100<br>111<br>1000<br>1001                             | Only valid when Register 0x0310, Bits[2:0] = 3'b111.<br><br>TB2 + HB4 + HB3 + HB2 + HB1 filter selection: decimate by 48 (complex to real disabled), or decimate by 24 (complex to real enabled).<br>FB2 + HB1 filter selection: decimate by 10 (complex to real disabled), or decimate by 5 (complex to real enabled).<br>FB2 + HB2 + HB1 filter selection: decimate by 20 (complex to real disabled), or decimate by 10 (complex to real enabled).<br>FB2 + HB3 + HB2 + HB1 filter selection: decimate by 40 (complex to real disabled), or decimate by 20 (complex to real enabled).<br>TB1 filter selection: decimate by 3 (decimate by 1.5 not supported).<br>FB2 + TB1 filter selection: decimate by 15 (decimate by 7.5 not supported).<br>HB2 + FB2 + TB1 filter selection: decimate by 30 (decimate by 15 not supported).  | 0x0   | R/W    |
|        |                   | 3     | Reserved                     |   | Reserved.   | 0x0   | R      |
|        |                   | 2     | DDC1 Q input select          | 0<br>1  | Channel A.<br>Channel B.  | 0x1   | R/W    |
|        |                   | 1     | Reserved                     |   | Reserved.   | 0x0   | R      |
|        |                   | 0     | DDC1 I input select          | 0<br>1  | Channel A.<br>Channel B.  | 0x1   | R/W    |
| 0x0334 | DDC1 NCO control  | [7:4] | DDC1 NCO channel select mode | 0<br>1<br>10<br>11<br>100<br>101<br>110<br>1000<br>1001<br>1010<br>1011 | For edge control, the internal counter wraps when the Register 0x0334, Bits[3:0] value is reached.<br><br>Use Register 0x0314, Bits[3:0]<br>2'b0, GPIO_B0, GPIO_A0.<br>2'b0, GPIO_B1, GPIO_A1.<br>2'b00, GPIO_A1, GPIO_A0.<br>2'b00, GPIO_B1, GPIO_B0.<br>GPIO_B1, GPIO_A1, GPIO_B0, GPIO_A0.<br>GPIO_B1, GPIO_B0, GPIO_A1, GPIO_A0.<br>Increment internal counter when rising edge of the GPIO_A0 pin.<br>Increment internal counter when rising edge of the GPIO_A1 pin.<br>Increment internal counter when rising edge of the GPIO_B0 pin.<br>Increment internal counter when rising edge of the GPIO_B1 pin.  | 0x0   | R/W    |



| Addr.  | Name                   | Bits  | Bit Name                             | Settings | Description   | Reset | Access |
|--------|------------------------|-------|--------------------------------------|----------|---|-------|--------|
|        |                        | [3:0] | DDC1 NCO register map channel select |          | NCO channel select register map control   | 0x0   | R/W    |
|        |                        |       |                                      | 0        | Select NCO Channel 0.   |       |        |
|        |                        |       |                                      | 1        | Select NCO Channel 1.   |       |        |
|        |                        |       |                                      | 10       | Select NCO Channel 2.   |       |        |
|        |                        |       |                                      | 11       | Select NCO Channel 3.   |       |        |
|        |                        |       |                                      | 100      | Select NCO Channel 4.   |       |        |
|        |                        |       |                                      | 101      | Select NCO Channel 5.   |       |        |
|        |                        |       |                                      | 110      | Select NCO Channel 6.   |       |        |
|        |                        |       |                                      | 111      | Select NCO Channel 7.   |       |        |
|        |                        |       |                                      | 1000     | Select NCO Channel 8.   |       |        |
|        |                        |       |                                      | 1001     | Select NCO Channel 9.   |       |        |
|        |                        |       |                                      | 1010     | Select NCO Channel 10.  |       |        |
|        |                        |       |                                      | 1011     | Select NCO Channel 11.  |       |        |
|        |                        |       |                                      | 1100     | Select NCO Channel 12.  |       |        |
|        |                        |       |                                      | 1101     | Select NCO Channel 13.  |       |        |
|        |                        |       |                                      | 1110     | Select NCO Channel 14.  |       |        |
|        |                        |       |                                      | 1111     | Select NCO Channel 15.  |       |        |
| 0x0335 | DDC1 phase control     | [7:4] | Reserved                             |          | Reserved.   | 0x0   | R      |
|        |                        | [3:0] | DDC1 phase update index              |          | Indexes the NCO channel for which the phase and offset is to be updated. The update method is based on the DDC phase update mode, which can be continuous or require chip transfer. | 0x0   | R/W    |
|        |                        |       |                                      | 0000     | Update NCO Channel 0.   |       |        |
|        |                        |       |                                      | 0001     | Update NCO Channel 1.   |       |        |
|        |                        |       |                                      | 0010     | Update NCO Channel 2.   |       |        |
|        |                        |       |                                      | 0011     | Update NCO Channel 3.   |       |        |
| 0x0336 | DDC1 Phase Increment 0 | [7:0] | DDC1 phase increment [7:0]           |          | FTW. Twos complement phase increment value for the NCO. Complex mixing frequency = $(DDC\ phase\ increment \times f_s)/2^{48}$ .  | 0x0   | R/W    |
| 0x0337 | DDC1 Phase Increment 1 | [7:0] | DDC1 phase increment [15:8]          |          | FTW. Twos complement phase increment value for the NCO. Complex mixing frequency = $(DDC\ phase\ increment \times f_s)/2^{48}$ .  | 0x0   | R/W    |
| 0x0338 | DDC1 Phase Increment 2 | [7:0] | DDC1 phase increment [23:16]         |          | FTW. Twos complement phase increment value for the NCO. Complex mixing frequency = $(DDC\ phase\ increment \times f_s)/2^{48}$ .  | 0x0   | R/W    |
| 0x0339 | DDC1 Phase Increment 3 | [7:0] | DDC1 phase increment [31:24]         |          | FTW. Twos complement phase increment value for the NCO. Complex mixing frequency = $(DDC\ phase\ increment \times f_s)/2^{48}$ .  | 0x0   | R/W    |
| 0x033A | DDC1 Phase Increment 4 | [7:0] | DDC1 phase increment [39:32]         |          | FTW. Twos complement phase increment value for the NCO. Complex mixing frequency = $(DDC\ phase\ increment \times f_s)/2^{48}$ .  | 0x0   | R/W    |
| 0x033B | DDC1 Phase Increment 5 | [7:0] | DDC1 phase increment [47:40]         |          | FTW. Twos complement phase increment value for the NCO. Complex mixing frequency = $(DDC\ phase\ increment \times f_s)/2^{48}$ .  | 0x0   | R/W    |
| 0x033D | DDC1 Phase Offset 0    | [7:0] | DDC1 phase offset [7:0]              |          | Twos complement phase offset value for the NCO.   | 0x0   | R/W    |
| 0x033E | DDC1 Phase Offset 1    | [7:0] | DDC1 phase offset [15:8]             |          | Twos complement phase offset value for the NCO.   | 0x0   | R/W    |
| 0x033F | DDC1 Phase Offset 2    | [7:0] | DDC1 phase offset [23:16]            |          | Twos complement phase offset value for the NCO.   | 0x0   | R/W    |
| 0x0340 | DDC1 Phase Offset 3    | [7:0] | DDC1 phase offset [31:24]            |          | Twos complement phase offset value for the NCO.   | 0x0   | R/W    |
| 0x0341 | DDC1 Phase Offset 4    | [7:0] | DDC1 phase offset [39:32]            |          | Twos complement phase offset value for the NCO.   | 0x0   | R/W    |
| 0x0342 | DDC1 Phase Offset 5    | [7:0] | DDC1 phase offset [47:40]            |          | Twos complement phase offset value for the NCO.   | 0x0   | R/W    |
| 0x0347 | DDC1 test enable       | [7:3] | Reserved                             |          | Reserved.   | 0x0   | R      |
|        |                        | 2     | DDC1 Q output test mode enable       |          | Q samples always use the Test Mode B block. The test mode is selected using the channel dependent Register 0x0550, Bits[3:0].   | 0x0   | R/W    |
|        |                        |       |                                      | 0        | Test mode disabled.   |       |        |
|        |                        |       |                                      | 1        | Test mode enabled.  |       |        |
|        |                        | 1     | Reserved                             |          | Reserved.   | 0x0   | R      |
|        |                        | 0     | DDC1 I output test mode enable       |          | I samples always use the Test Mode A block. The test mode is selected using the channel dependent Register 0x0550, Bits[3:0].   | 0x0   | R/W    |
|        |                        |       |                                      | 0        | Test mode disabled.   |       |        |
|        |                        |       |                                      | 1        | Test mode enabled.  |       |        |

| Addr.  | Name                        | Bits      | Bit Name  | Settings  | Description   | Reset | Access |
|--------|-----------------------------|-----------|---|-----------|---|-------|--------|
| 0x0350 | DDC2 control                | 7         | DDC2 mixer select   | 0         | Real mixer (I and Q inputs must be from the same real channel)  | 0x0   | R/W    |
|        |                             |           |   | 1         | Complex mixer (I and Q must be from separate, real and imaginary quadrature ADC receive channels; analog demodulator)   |       |        |
|        |                             | 6         | DDC2 gain select  | 0         | Gain can be used to compensates for the 6 dB loss associated with mixing an input signal down to baseband and filtering out its negative component.   | 0x0   | R/W    |
|        |                             |           |   | 1         | 0 dB gain.<br>6 dB gain (multiply by 2).  |       |        |
|        |                             | [5:4]     | DDC2 intermediate frequency (IF) mode   | 00        | Variable IF mode.   | 0x0   | R/W    |
|        |                             |           |   | 01        | 0 Hz IF mode.   |       |        |
| 10     | $f_s$ Hz IF mode.           |           |   |           |   |       |        |
| 11     | Test mode.                  |           |   |           |   |       |        |
| 3      | DDC2 complex to real enable | 0         | Complex (I and Q) outputs contain valid data.   | 0x0       | R/W   |       |        |
|        |                             | 1         | Real (I) output only. Complex to real enabled. Uses extra $f_s$ mixing to convert to real.  |           |   |       |        |
| [2:0]  | DDC2 decimation rate select | 000       | Decimation filter selection.  | 0x0       | R/W   |       |        |
|        |                             | 001       | HB1 + HB2 filter selection: decimate by 2 (complex to real enabled), or decimate by 4 (complex to real disabled).   |           |   |       |        |
|        |                             | 010       | HB1 + HB2 + HB3 filter selection: decimate by 4 (complex to real enabled), or decimate by 8 (complex to real disabled).   |           |   |       |        |
|        |                             | 011       | HB1 + HB2 + HB3 + HB4 filter selection: decimate by 8 (complex to real enabled), or decimate by 16 (complex to real disabled).  |           |   |       |        |
|        |                             | 100       | HB1 filter selection: decimate by 1 (complex to real enabled), or decimate by 2 (complex to real disabled).   |           |   |       |        |
|        |                             | 101       | HB1 + TB2 filter selection: decimate by 3 (complex to real enabled), or decimate by 6 (complex to real disabled).   |           |   |       |        |
|        |                             | 110       | HB1 + HB2 + TB2 filter selection: decimate by 6 (complex to real enabled), or decimate by 12 (complex to real disabled).  |           |   |       |        |
|        |                             | 111       | HB1 + HB2 + HB3 + TB2 filter selection: decimate by 12 (complex to real enabled), or decimate by 24 (complex to real disabled).<br>Decimation determined by Register 0x0351, Bits[7:4]. |           |   |       |        |
| 0x0351 | DDC2 input select           | [7:4]     | DDC2 decimation rate select   | 0         | Only valid when Register 0x0310, Bits[2:0] = 3'b111.<br>TB2 + HB4 + HB3 + HB2 + HB1 filter selection: decimate by 48 (complex to real disabled), or decimate by 24 (complex to real enabled). | 0x0   | R/W    |
|        |                             |           |   | 10        | FB2 + HB1 filter selection: decimate by 10 (complex to real disabled), or decimate by 5 (complex to real enabled).  |       |        |
|        |                             |           |   | 11        | FB2 + HB2 + HB1 filter selection: decimate by 20 (complex to real disabled), or decimate by 10 (complex to real enabled).   |       |        |
|        |                             |           |   | 100       | FB2 + HB3 + HB2 + HB1 filter selection: decimate by 40 (complex to real disabled), or decimate by 20 (complex to real enabled).   |       |        |
|        |                             | 3         | Reserved  | Reserved. | 0x0   | R     |        |
|        |                             | 2         | DDC2 Q input select   | 0         | Channel A.  | 0x0   | R/W    |
|        |                             |           |   | 1         | Channel B.  |       |        |
| 1      | Reserved                    | Reserved. | 0x0   | R         |   |       |        |
| 0      | DDC2 I input select         | 0         | Channel A.  | 0x0       | R/W   |       |        |
|        |                             | 1         | Channel B.  |           |   |       |        |

| Addr.  | Name                   | Bits  | Bit Name                             | Settings  | Description   | Reset | Access |
|--------|------------------------|-------|--------------------------------------|---|---|-------|--------|
| 0x0354 | DDC2 NCO control       | [7:4] | DDC2 NCO channel select mode         | 0 Use 0x0314[3:0]<br>1 2'b0, GPIO B0, GPIO A0.<br>10 2'b0, GPIO B1, GPIO A1.<br>11 2'b00, GPIO A1, GPIO A0.<br>100 2'b00, GPIO B1, GPIO B0.<br>101 GPIO B1, GPIO A1, GPIO B0, GPIO A0.<br>110 GPIO B1, GPIO B0, GPIO A1, GPIO A0.<br>1000 Increment internal counter when rising edge of the GPIO_A0 pin.<br>1001 Increment internal counter when rising edge of the GPIO_A1 pin.<br>1010 Increment internal counter when rising edge of the GPIO_B0 pin.<br>1011 Increment internal counter when rising edge of the GPIO_B1 pin. | For edge control, the internal counter wraps when the Register 0x0354, Bits[3:0] value is reached.  | 0x0   | R/W    |
|        |                        | [3:0] | DDC2 NCO register map channel select | 0 Select NCO Channel 0.<br>1 Select NCO Channel 1.<br>10 Select NCO Channel 2.<br>11 Select NCO Channel 3.<br>100 Select NCO Channel 4.<br>101 Select NCO Channel 5.<br>110 Select NCO Channel 6.<br>111 Select NCO Channel 7.<br>1000 Select NCO Channel 8.<br>1001 Select NCO Channel 9.<br>1010 Select NCO Channel 10.<br>1011 Select NCO Channel 11.<br>1100 Select NCO Channel 12.<br>1101 Select NCO Channel 13.<br>1110 Select NCO Channel 14.<br>1111 Select NCO Channel 15.  | NCO channel select register map control.  | 0x0   | R/W    |
| 0x0355 | DDC2 phase control     | [7:4] | Reserved                             |   | Reserved.   | 0x0   | R      |
|        |                        | [3:0] | DDC2 phase update index              | 0000 Update NCO Channel 0.<br>0001 Update NCO Channel 1.<br>0010 Update NCO Channel 2.<br>0011 Update NCO Channel 3.  | Indexes the NCO channel whose phase and offset gets updated. The update method is based on the DDC phase update mode, which can be continuous or require chip transfer. | 0x0   | R/W    |
| 0x0356 | DDC2 Phase Increment 0 | [7:0] | DDC2 phase increment [7:0]           |   | FTW. Twos complement phase increment value for the NCO. Complex mixing frequency = $(DDC \text{ phase increment} \times f_s)/2^{48}$ .                                  | 0x0   | R/W    |
| 0x0357 | DDC2 Phase Increment 1 | [7:0] | DDC2 phase increment [15:8]          |   | FTW. Twos complement phase increment value for the NCO. Complex mixing frequency = $(DDC \text{ phase increment} \times f_s)/2^{48}$ .                                  | 0x0   | R/W    |
| 0x0358 | DDC2 Phase Increment 2 | [7:0] | DDC2 phase increment [23:16]         |   | FTW. Twos complement phase increment value for the NCO. Complex mixing frequency = $(DDC \text{ phase increment} \times f_s)/2^{48}$ .                                  | 0x0   | R/W    |
| 0x0359 | DDC2 Phase Increment 3 | [7:0] | DDC2 phase increment [31:24]         |   | FTW. Twos complement phase increment value for the NCO. Complex mixing frequency = $(DDC \text{ phase increment} \times f_s)/2^{48}$ .                                  | 0x0   | R/W    |
| 0x035A | DDC2 Phase Increment 4 | [7:0] | DDC2 phase increment [39:32]         |   | FTW. Twos complement phase increment value for the NCO. Complex mixing frequency = $(DDC \text{ phase increment} \times f_s)/2^{48}$ .                                  | 0x0   | R/W    |
| 0x035B | DDC2 Phase Increment 5 | [7:0] | DDC2 phase increment [47:40]         |   | FTW. Twos complement phase increment value for the NCO. Complex mixing frequency = $(DDC \text{ phase increment} \times f_s)/2^{48}$ .                                  | 0x0   | R/W    |
| 0x035D | DDC2 Phase Offset 0    | [7:0] | DDC2 phase offset [7:0]              |   | Twos complement phase offset value for the NCO.   | 0x0   | R/W    |
| 0x035E | DDC2 Phase Offset 1    | [7:0] | DDC2 phase offset [15:8]             |   | Twos complement phase offset value for the NCO.   | 0x0   | R/W    |
| 0x035F | DDC2 Phase Offset 2    | [7:0] | DDC2 phase offset [23:16]            |   | Twos complement phase offset value for the NCO.   | 0x0   | R/W    |
| 0x0360 | DDC2 Phase Offset 3    | [7:0] | DDC2 phase offset [31:24]            |   | Twos complement phase offset value for the NCO.   | 0x0   | R/W    |

| Addr.  | Name                | Bits  | Bit Name                              | Settings   | Description   | Reset  | Access  |     |
|--------|---------------------|-------|---------------------------------------|--|---|--|---|-----|
| 0x0361 | DDC2 Phase Offset 4 | [7:0] | DDC2 phase offset [39:32]             |  | Twos complement phase offset value for the NCO.   | 0x0  | R/W   |     |
| 0x0362 | DDC2 Phase Offset 5 | [7:0] | DDC2 phase offset [47:40]             |  | Twos complement phase offset value for the NCO.   | 0x0  | R/W   |     |
| 0x0367 | DDC2 test enable    | [7:3] | Reserved                              |  | Reserved.   | 0x0  | R   |     |
|        |                     |       | 2                                     | DDC2 Q output test mode enable                       | 0<br>1  | Q samples always use the Test Mode B block. The test mode is selected using the channel dependent Register 0x0550, Bits[3:0].<br>Test mode disabled.<br>Test mode enabled. | 0x0   | R/W |
|        |                     |       | 1                                     | Reserved   |   | Reserved.  | 0x0   | R   |
|        |                     |       | 0                                     | DDC2 I output test mode enable                       | 0<br>1  | I samples always use the Test Mode A block. The test mode is selected using the channel dependent Register 0x0550, Bits[3:0].<br>Test mode disabled.<br>Test mode enabled. | 0x0   | R/W |
| 0x0370 | DDC3 control        | 7     | DDC3 mixer select                     | 0<br>1   | Real mixer (I and Q inputs must be from the same real channel).<br>Complex mixer (I and Q must be from separate, real and imaginary quadrature ADC receive channels; analog demodulator).   | 0x0  | R/W   |     |
|        |                     |       |                                       | 6  | DDC3 gain select  | 0<br>1   | Gain can be used to compensate for the 6 dB loss associated with mixing an input signal down to baseband and filtering out its negative component.<br>0 dB gain.<br>6 dB gain (multiply by 2) | 0x0 |
|        |                     | [5:4] | DDC3 intermediate frequency (IF) mode | 00<br>01<br>10<br>11                                 | Variable IF mode.<br>0 Hz IF mode.<br>$f_s$ Hz IF mode.<br>Test mode.   | 0x0  | R/W   |     |
|        |                     | 3     | DDC3 complex to real enable           | 0<br>1   | Complex (I and Q) outputs contain valid data.<br>Real (I) output only. complex to real enabled. Uses extra $f_s$ mixing to convert to real.   | 0x0  | R/W   |     |
|        |                     | [2:0] | DDC3 decimation rate select           | 000<br>001<br>010<br>011<br>100<br>101<br>110<br>111 | Decimation filter selection.<br>HB1 + HB2 filter selection: decimate by 2 (complex to real enabled), or decimate by 4 (complex to real disabled).<br>HB1 + HB2 + HB3 filter selection: decimate by 4 (complex to real enabled), or decimate by 8 (complex to real disabled).<br>HB1 + HB2 + HB3 + HB4 filter selection: decimate by 8 (complex to real enabled), or decimate by 16 (complex to real disabled).<br>HB1 filter selection: decimate by 1 (complex to real enabled), or decimate by 2 (complex to real disabled).<br>HB1 + TB2 filter selection: decimate by 3 (complex to real enabled), or decimate by 6 (complex to real disabled).<br>HB1 + HB2 + TB2 filter selection: decimate by 6 (complex to real enabled), or decimate by 12 (complex to real disabled).<br>HB1 + HB2 + HB3 + TB2 filter selection: decimate by 12 (complex to real enabled), or decimate by 24 (complex to real disabled).<br>Decimation determined by Register 0x0371, Bits[7:4]. | 0x0  | R/W   |     |

| Addr.  | Name                   | Bits  | Bit Name                             | Settings   | Description   | Reset | Access |
|--------|------------------------|---|--------------------------------------|--|---|-------|--------|
| 0x0371 | DDC3 input select      | [7:4]   | DDC3 decimation rate select          |  | Only valid when Register 0x0310, Bits[2:0] = 3'b111.  | 0x0   | R/W    |
|        |                        |   |                                      | 0  | TB2 + HB4 + HB3 + HB2 + HB1 filter selection: decimate by 48 (complex to real disabled), or decimate by 24 (complex to real enabled).                                   |       |        |
|        |                        |   |                                      | 10   | FB2 + HB1 filter selection: decimate by 10 (complex to real disabled), or decimate by 5 (complex to real enabled)   |       |        |
|        |                        |   |                                      | 11   | FB2 + HB2 + HB1 filter selection: decimate by 20 (complex to real disabled), or decimate by 10 (complex to real enabled)  |       |        |
|        |                        |   | 100                                  | FB2 + HB3 + HB2 + HB1 filter selection: decimate by 40 (complex to real disabled), or decimate by 20 (complex to real enabled) |   |       |        |
|        |                        | 3   | Reserved                             |  | Reserved.   | 0x0   | R      |
| 0x0374 | DDC3 NCO control       | [7:4]   | DDC3 NCO channel select mode         |  | For edge control, the internal counter wraps when the Register 0x0374, Bits[3:0] value is reached.  | 0x0   | R/W    |
|        |                        |   |                                      | 0  | Use Register 0x0314, Bits[3:0].   |       |        |
|        |                        |   |                                      | 1  | 2'b0, GPIO B0, GPIO A0.   |       |        |
|        |                        |   |                                      | 10   | 2'b0, GPIO B1, GPIO A1.   |       |        |
|        | 11                     | 2'b00, GPIO A1, GPIO A0.                                    |                                      |  |   |       |        |
|        | 100                    | 2'b00, GPIO B1, GPIO B0.                                    |                                      |  |   |       |        |
|        | 101                    | GPIO B1, GPIO A1, GPIO B0, GPIO A0.                         |                                      |  |   |       |        |
|        | 110                    | GPIO B1, GPIO B0, GPIO A1, GPIO A0.                         |                                      |  |   |       |        |
|        | 1000                   | Increment internal counter when rising edge of GPIO_A0 pin. |                                      |  |   |       |        |
|        | 1001                   | Increment internal counter when rising edge of GPIO_A1 pin. |                                      |  |   |       |        |
|        | 1010                   | Increment internal counter when rising edge of GPIO_B0 pin. |                                      |  |   |       |        |
|        | 1011                   | Increment internal counter when rising edge of GPIO_B1 pin. |                                      |  |   |       |        |
| 0x0374 | DDC3 NCO control       | [3:0]   | DDC3 NCO register map channel select |  | NCO channel select register map control.  | 0x0   | R/W    |
|        |                        |   |                                      | 0  | Select NCO Channel 0.   |       |        |
|        |                        |   |                                      | 1  | Select NCO Channel 1.   |       |        |
|        |                        |   |                                      | 10   | Select NCO Channel 2.   |       |        |
|        |                        |   |                                      | 11   | Select NCO Channel 3.   |       |        |
|        |                        |   |                                      | 100  | Select NCO Channel 4.   |       |        |
|        |                        |   |                                      | 101  | Select NCO Channel 5.   |       |        |
|        |                        |   |                                      | 110  | Select NCO Channel 6.   |       |        |
|        |                        |   |                                      | 111  | Select NCO Channel 7.   |       |        |
|        |                        |   |                                      | 1000   | Select NCO Channel 8.   |       |        |
|        |                        |   |                                      | 1001   | Select NCO Channel 9.   |       |        |
|        |                        |   |                                      | 1010   | Select NCO Channel 10.  |       |        |
|        |                        |   |                                      | 1011   | Select NCO Channel 11.  |       |        |
|        |                        |   |                                      | 1100   | Select NCO Channel 12.  |       |        |
|        |                        |   |                                      | 1101   | Select NCO Channel 13.  |       |        |
| 1110   | Select NCO Channel 14. |   |                                      |  |   |       |        |
| 1111   | Select NCO Channel 15. |   |                                      |  |   |       |        |
| 0x0375 | DDC3 phase control     | [7:4]   | Reserved                             |  | Reserved.   | 0x0   | R      |
|        |                        | [3:0]   | DDC3 phase update index              |  | Indexes the NCO channel whose phase and offset gets updated. The update method is based on the DDC phase update mode, which can be continuous or require chip transfer. | 0x0   | R/W    |
|        |                        |   |                                      | 0000   | Update NCO Channel 0.   |       |        |
|        |                        |   |                                      | 0001   | Update NCO Channel 1.   |       |        |
|        |                        |   |                                      | 0010   | Update NCO Channel 2.   |       |        |
|        |                        |   |                                      | 0011   | Update NCO Channel 3.   |       |        |

| Addr.  | Name                               | Bits  | Bit Name                                  | Settings | Description  | Reset | Access |
|--------|------------------------------------|-------|---|----------|--|-------|--------|
| 0x0376 | DDC3 Phase Increment 0             | [7:0] | DDC3 phase increment [7:0]                |          | FTW. Twos complement phase increment value for the NCO. Complex mixing frequency = $(DDC \text{ phase increment} \times f_s)/2^{48}$ .                                     | 0x0   | R/W    |
| 0x0377 | DDC3 Phase Increment 1             | [7:0] | DDC3 phase increment [15:8]               |          | FTW. Twos complement phase increment value for the NCO. Complex mixing frequency = $(DDC \text{ phase increment} \times f_s)/2^{48}$ .                                     | 0x0   | R/W    |
| 0x0378 | DDC3 Phase Increment 2             | [7:0] | DDC3 phase increment [23:16]              |          | FTW. Twos complement phase increment value for the NCO. Complex mixing frequency = $(DDC \text{ phase increment} \times f_s)/2^{48}$ .                                     | 0x0   | R/W    |
| 0x0379 | DDC3 Phase Increment 3             | [7:0] | DDC3 phase increment [31:24]              |          | FTW. Twos complement phase increment value for the NCO. Complex mixing frequency = $(DDC \text{ phase increment} \times f_s)/2^{48}$ .                                     | 0x0   | R/W    |
| 0x037A | DDC3 Phase Increment 4             | [7:0] | DDC3 phase increment [39:32]              |          | FTW. Twos complement phase increment value for the NCO. Complex mixing frequency = $(DDC \text{ phase increment} \times f_s)/2^{48}$ .                                     | 0x0   | R/W    |
| 0x037B | DDC3 Phase Increment 5             | [7:0] | DDC3 phase increment [47:40]              |          | FTW. Twos complement phase increment value for the NCO. Complex mixing frequency = $(DDC \text{ phase increment} \times f_s)/2^{48}$ .                                     | 0x0   | R/W    |
| 0x037D | DDC3 Phase Offset 0                | [7:0] | DDC3 phase offset [7:0]                   |          | Twos complement phase offset value for the NCO.  | 0x0   | R/W    |
| 0x037E | DDC3 Phase Offset 1                | [7:0] | DDC3 phase offset [15:8]                  |          | Twos complement phase offset value for the NCO.  | 0x0   | R/W    |
| 0x037F | DDC3 Phase Offset 2                | [7:0] | DDC3 phase offset [23:16]                 |          | Twos complement phase offset value for the NCO.  | 0x0   | R/W    |
| 0x0380 | DDC3 Phase Offset 3                | [7:0] | DDC3 phase offset [31:24]                 |          | Twos complement phase offset value for the NCO.  | 0x0   | R/W    |
| 0x0381 | DDC3 Phase Offset 4                | [7:0] | DDC3 phase offset [39:32]                 |          | Twos complement phase offset value for the NCO.  | 0x0   | R/W    |
| 0x0382 | DDC3 Phase Offset 5                | [7:0] | DDC3 phase offset [47:40]                 |          | Twos complement phase offset value for the NCO.  | 0x0   | R/W    |
| 0x0387 | DDC3 test enable                   | [7:3] | Reserved                                  |          | Reserved.  | 0x0   | R      |
|        |                                    | 2     | DDC3 Q output test mode enable            | 0<br>1   | Q samples always use the Test Mode B block. The test mode is selected using the channel dependent Register 0x0550, Bits[3:0].<br>Test mode disabled.<br>Test mode enabled. | 0x0   | R/W    |
|        |                                    | 1     | Reserved                                  |          | Reserved.  | 0x0   | R      |
|        |                                    | 0     | DDC3 I output test mode enable            | 0<br>1   | I samples always use the Test Mode A block. The test mode is selected using the channel dependent Register 0x0550, Bits[3:0].<br>Test mode disabled.<br>Test mode enabled. | 0x0   | R/W    |
| 0x0390 | DDC0 Phase Increment Fractional A0 | [7:0] | DDC0 Phase Increment Fractional A [7:0]   |          | Numerator correction term for Modulus Phase Accumulator A.   | 0x0   | R/W    |
| 0x0391 | DDC0 Phase Increment Fractional A1 | [7:0] | DDC0 Phase Increment Fractional A [15:8]  |          | Numerator correction term for Modulus Phase Accumulator A.   | 0x0   | R/W    |
| 0x0392 | DDC0 Phase Increment Fractional A2 | [7:0] | DDC0 Phase Increment Fractional A [23:16] |          | Numerator correction term for Modulus Phase Accumulator A.   | 0x0   | R/W    |
| 0x0393 | DDC0 Phase Increment Fractional A3 | [7:0] | DDC0 Phase Increment Fractional A [31:24] |          | Numerator correction term for Modulus Phase Accumulator A.   | 0x0   | R/W    |
| 0x0394 | DDC0 Phase Increment Fractional A4 | [7:0] | DDC0 Phase Increment Fractional A [39:32] |          | Numerator correction term for Modulus Phase Accumulator A.   | 0x0   | R/W    |
| 0x0395 | DDC0 Phase Increment Fractional A5 | [7:0] | DDC0 Phase Increment Fractional A [47:40] |          | Numerator correction term for Modulus Phase Accumulator A.   | 0x0   | R/W    |
| 0x0398 | DDC0 Phase Increment Fractional B0 | [7:0] | DDC0 Phase Increment Fractional B [7:0]   |          | Denominator correction term for Modulus Phase Accumulator B.   | 0x0   | R/W    |
| 0x0399 | DDC0 Phase Increment Fractional B1 | [7:0] | DDC0 Phase Increment Fractional B [15:8]  |          | Denominator correction term for Modulus Phase Accumulator B.   | 0x0   | R/W    |
| 0x039A | DDC0 Phase Increment Fractional B2 | [7:0] | DDC0 Phase Increment Fractional B [23:16] |          | Denominator correction term for Modulus Phase Accumulator B.   | 0x0   | R/W    |
| 0x039B | DDC0 Phase Increment Fractional B3 | [7:0] | DDC0 Phase Increment Fractional B [31:24] |          | Denominator correction term for Modulus Phase Accumulator B.   | 0x0   | R/W    |

| Addr.  | Name                               | Bits  | Bit Name                                  | Settings | Description  | Reset | Access |
|--------|------------------------------------|-------|---|----------|--|-------|--------|
| 0x039C | DDC0 Phase Increment Fractional B4 | [7:0] | DDC0 Phase Increment Fractional B [39:32] |          | Denominator correction term for Modulus Phase Accumulator B. | 0x0   | R/W    |
| 0x039D | DDC0 Phase Increment Fractional B5 | [7:0] | DDC0 Phase Increment Fractional B [47:40] |          | Denominator correction term for Modulus Phase Accumulator B. | 0x0   | R/W    |
| 0x03A0 | DDC1 Phase Increment Fractional A0 | [7:0] | DDC1 Phase Increment Fractional A [7:0]   |          | Numerator correction term for Modulus Phase Accumulator A.   | 0x0   | R/W    |
| 0x03A1 | DDC1 Phase Increment Fractional A1 | [7:0] | DDC1 Phase Increment Fractional A [15:8]  |          | Numerator correction term for Modulus Phase Accumulator A.   | 0x0   | R/W    |
| 0x03A2 | DDC1 Phase Increment Fractional A2 | [7:0] | DDC1 Phase Increment Fractional A [23:16] |          | Numerator correction term for Modulus Phase Accumulator A.   | 0x0   | R/W    |
| 0x03A3 | DDC1 Phase Increment Fractional A3 | [7:0] | DDC1 Phase Increment Fractional A [31:24] |          | Numerator correction term for Modulus Phase Accumulator A.   | 0x0   | R/W    |
| 0x03A4 | DDC1 Phase Increment Fractional A4 | [7:0] | DDC1 Phase Increment Fractional A [39:32] |          | Numerator correction term for Modulus Phase Accumulator A.   | 0x0   | R/W    |
| 0x03A5 | DDC1 Phase Increment Fractional A5 | [7:0] | DDC1 Phase Increment Fractional A [47:40] |          | Numerator correction term for Modulus Phase Accumulator A.   | 0x0   | R/W    |
| 0x03A8 | DDC1 Phase Increment Fractional B0 | [7:0] | DDC1 Phase Increment Fractional B [7:0]   |          | Denominator correction term for Modulus Phase Accumulator B. | 0x0   | R/W    |
| 0x03A9 | DDC1 Phase Increment Fractional B1 | [7:0] | DDC1 Phase Increment Fractional B [15:8]  |          | Denominator correction term for Modulus Phase Accumulator B. | 0x0   | R/W    |
| 0x03AA | DDC1 Phase Increment Fractional B2 | [7:0] | DDC1 Phase Increment Fractional B [23:16] |          | Denominator correction term for Modulus Phase Accumulator B. | 0x0   | R/W    |
| 0x03AB | DDC1 Phase Increment Fractional B3 | [7:0] | DDC1 Phase Increment Fractional B [31:24] |          | Denominator correction term for Modulus Phase Accumulator B. | 0x0   | R/W    |
| 0x03AC | DDC1 Phase Increment Fractional B4 | [7:0] | DDC1 Phase Increment Fractional B [39:32] |          | Denominator correction term for Modulus Phase Accumulator B. | 0x0   | R/W    |
| 0x03AD | DDC1 Phase Increment Fractional B5 | [7:0] | DDC1 Phase Increment Fractional B [47:40] |          | Denominator correction term for Modulus Phase Accumulator B. | 0x0   | R/W    |
| 0x03B0 | DDC2 Phase Increment Fractional A0 | [7:0] | DDC2 Phase Increment Fractional A [7:0]   |          | Numerator correction term for Modulus Phase Accumulator A.   | 0x0   | R/W    |
| 0x03B1 | DDC2 Phase Increment Fractional A1 | [7:0] | DDC2 Phase Increment Fractional A [15:8]  |          | Numerator correction term for Modulus Phase Accumulator A.   | 0x0   | R/W    |
| 0x03B2 | DDC2 Phase Increment Fractional A2 | [7:0] | DDC2 Phase Increment Fractional A [23:16] |          | Numerator correction term for Modulus Phase Accumulator A.   | 0x0   | R/W    |
| 0x03B3 | DDC2 Phase Increment Fractional A3 | [7:0] | DDC2 Phase Increment Fractional A [31:24] |          | Numerator correction term for Modulus Phase Accumulator A.   | 0x0   | R/W    |
| 0x03B4 | DDC2 Phase Increment Fractional A4 | [7:0] | DDC2 Phase Increment Fractional A [39:32] |          | Numerator correction term for Modulus Phase Accumulator A.   | 0x0   | R/W    |
| 0x03B5 | DDC2 Phase Increment Fractional A5 | [7:0] | DDC2 Phase Increment Fractional A [47:40] |          | Numerator correction term for Modulus Phase Accumulator A.   | 0x0   | R/W    |
| 0x03B8 | DDC2 Phase Increment Fractional B0 | [7:0] | DDC2 Phase Increment Fractional B [7:0]   |          | Denominator correction term for Modulus Phase Accumulator B. | 0x0   | R/W    |
| 0x03B9 | DDC2 Phase Increment Fractional B1 | [7:0] | DDC2 Phase Increment Fractional B [15:8]  |          | Denominator correction term for Modulus Phase Accumulator B. | 0x0   | R/W    |

| Addr.  | Name                               | Bits  | Bit Name                                  | Settings | Description  | Reset | Access |
|--------|------------------------------------|-------|---|----------|--|-------|--------|
| 0x03BA | DDC2 Phase Increment Fractional B2 | [7:0] | DDC2 Phase Increment Fractional B [23:16] |          | Denominator correction term for Modulus Phase Accumulator B. | 0x0   | R/W    |
| 0x03BB | DDC2 Phase Increment Fractional B3 | [7:0] | DDC2 Phase Increment Fractional B [31:24] |          | Denominator correction term for Modulus Phase Accumulator B. | 0x0   | R/W    |
| 0x03BC | DDC2 Phase Increment Fractional B4 | [7:0] | DDC2 Phase Increment Fractional B [39:32] |          | Denominator correction term for Modulus Phase Accumulator B. | 0x0   | R/W    |
| 0x03BD | DDC2 Phase Increment Fractional B5 | [7:0] | DDC2 Phase Increment Fractional B [47:40] |          | Denominator correction term for Modulus Phase Accumulator B. | 0x0   | R/W    |
| 0x03C0 | DDC3 Phase Increment Fractional A0 | [7:0] | DDC3 Phase Increment Fractional A [7:0]   |          | Numerator correction term for Modulus Phase Accumulator A.   | 0x0   | R/W    |
| 0x03C1 | DDC3 Phase Increment Fractional A1 | [7:0] | DDC3 Phase Increment Fractional A [15:8]  |          | Numerator correction term for Modulus Phase Accumulator A.   | 0x0   | R/W    |
| 0x03C2 | DDC3 Phase Increment Fractional A2 | [7:0] | DDC3 Phase Increment Fractional A [23:16] |          | Numerator correction term for Modulus Phase Accumulator A.   | 0x0   | R/W    |
| 0x03C3 | DDC3 Phase Increment Fractional A3 | [7:0] | DDC3 Phase Increment Fractional A [31:24] |          | Numerator correction term for Modulus Phase Accumulator A.   | 0x0   | R/W    |
| 0x03C4 | DDC3 Phase Increment Fractional A4 | [7:0] | DDC3 Phase Increment Fractional A [39:32] |          | Numerator correction term for Modulus Phase Accumulator A.   | 0x0   | R/W    |
| 0x03C5 | DDC3 Phase Increment Fractional A5 | [7:0] | DDC3 Phase Increment Fractional A [47:40] |          | Numerator correction term for Modulus Phase Accumulator A.   | 0x0   | R/W    |
| 0x03C8 | DDC3 Phase Increment Fractional B0 | [7:0] | DDC3 Phase Increment Fractional B [7:0]   |          | Denominator correction term for Modulus Phase Accumulator B. | 0x0   | R/W    |
| 0x03C9 | DDC3 Phase Increment Fractional B1 | [7:0] | DDC3 Phase Increment Fractional B [15:8]  |          | Denominator correction term for Modulus Phase Accumulator B. | 0x0   | R/W    |
| 0x03CA | DDC3 Phase Increment Fractional B2 | [7:0] | DDC3 Phase Increment Fractional B [23:16] |          | Denominator correction term for Modulus Phase Accumulator B. | 0x0   | R/W    |
| 0x03CB | DDC3 Phase Increment Fractional B3 | [7:0] | DDC3 Phase Increment Fractional B [31:24] |          | Denominator correction term for Modulus Phase Accumulator B. | 0x0   | R/W    |
| 0x03CC | DDC3 Phase Increment Fractional B4 | [7:0] | DDC3 Phase Increment Fractional B [39:32] |          | Denominator correction term for Modulus Phase Accumulator B. | 0x0   | R/W    |
| 0x03CD | DDC3 Phase Increment Fractional B5 | [7:0] | DDC3 Phase Increment Fractional B [47:40] |          | Denominator correction term for Modulus Phase Accumulator B. | 0x0   | R/W    |

## Digital Outputs and Test Modes Registers

|        |                               |   |                         |   |  |     |     |
|--------|-------------------------------|---|-------------------------|---|--|-----|-----|
| 0x0550 | ADC test mode control (local) | 7 | User pattern selection  | 0 | Test mode user pattern selection. This bit is only used when Register 0x0550, Bits[3:0] = 4'b1000 (user input mode). Otherwise, it is ignored. User Pattern 1 is found in the User Pattern 1 MSB register (Register 0x0552) and the User Pattern 1 LSB (Register 0x0551) registers. User Pattern 2 is found in the User Pattern 2 MSB register (Register 0x0554) and the User Patter 2 LSB (Register 0x0553) register, and so on.<br>Continuous/repeat pattern. Place each user pattern (1, 2, 3, and 4) on the output for 1 clock cycle and then repeat. (Output User Pattern 1, 2, 3, 4, 1, 2, 3, 4, 1, 2, 3, 4, and so on.) | 0x0 | R/W |
|        |                               |   |                         | 1 | Single pattern. Place each user pattern (1, 2, 3, and 4) on the output for 1 clock cycle and then output all zeros. (Output User Pattern 1, 2, 3, 4, and then output all zeros)  |     |     |
|        |                               | 6 | Reserved                |   | Reserved.  | 0x0 | R   |
|        |                               | 5 | Reset PN long generator | 0 | Test mode long pseudorandom number test generator reset. Long PN enabled.  | 0x0 | R/W |
|        |                               |   |                         | 1 | Long PN held in reset.   |     |     |



| Addr.  | Name                  | Bits  | Bit Name                          | Settings   | Description   | Reset | Access |
|--------|-----------------------|-------|-----------------------------------|--|---|-------|--------|
|        |                       | 4     | Reset PN short generator          | 0<br>1   | Test mode short pseudorandom number test generator reset.<br>Short PN enabled.<br>Short PN held in reset.   | 0x0   | R/W    |
|        |                       | [3:0] | Test mode selection               | 0000<br>0001<br>0010<br>0011<br>0100<br>0101<br>0110<br>0111<br>1000<br>1111 | Test mode generation selection.<br>Off (normal operation).<br>Midscale short.<br>Positive full scale.<br>Negative full scale.<br>Alternating checker board.<br>PN sequence (long).<br>PN sequence (short).<br>1/0 word toggle.<br>User pattern test mode (used with Register 0x0550, Bit 7 and the User Pattern 1, User Pattern 2, User Pattern 3, and User Pattern 4 registers).<br>Ramp output. | 0x0   | R/W    |
| 0x0551 | User Pattern 1 LSB    | [7:0] | User Pattern 1 [7:0]              |  | User Test Pattern 1 least significant byte.   | 0x0   | R/W    |
| 0x0552 | User Pattern 1 MSB    | [7:0] | User Pattern 1 [15:8]             |  | User Test Pattern 1 least significant byte.   | 0x0   | R/W    |
| 0x0553 | User Pattern 2 LSB    | [7:0] | User Pattern 2 [7:0]              |  | User Test Pattern 2 least significant byte.   | 0x0   | R/W    |
| 0x0554 | User Pattern 2 MSB    | [7:0] | User Pattern 2 [15:8]             |  | User Test Pattern 2 least significant byte.   | 0x0   | R/W    |
| 0x0555 | User Pattern 3 LSB    | [7:0] | User Pattern 3 [7:0]              |  | User Test Pattern 3 least significant bits.   | 0x0   | R/W    |
| 0x0556 | User Pattern 3 MSB    | [7:0] | User Pattern 3 [15:8]             |  | User Test Pattern 3 least significant bits.   | 0x0   | R/W    |
| 0x0557 | User Pattern 4 LSB    | [7:0] | User Pattern 4 [7:0]              |  | User Test Pattern 4 least significant bits.   | 0x0   | R/W    |
| 0x0558 | User Pattern 4 MSB    | [7:0] | User Pattern 4 [15:8]             |  | User Test Pattern 4 least significant bits.   | 0x0   | R/W    |
| 0x0559 | Output Mode Control 1 | [7:4] | Converter control Bit 1 selection | 0000<br>0001<br>0010<br>0011<br>0101   | Tie low (1'b0).<br>Overrange bit.<br>Signal monitor bit.<br>Fast detect (FD) bit.<br>SYSREF.  | 0x0   | R/W    |
|        |                       | [3:0] | Converter control Bit 0 selection | 0000<br>0001<br>0010<br>0011<br>0101   | Tie low (1'b0).<br>Overrange bit.<br>Signal monitor bit.<br>Fast detect (FD) bit.<br>SYSREF.  | 0x0   | R/W    |
| 0x055A | Output Mode Control 2 | [7:4] | Reserved                          |  | Reserved.   | 0x0   | R      |
|        |                       | [3:0] | Converter control Bit 2 selection | 0000<br>0001<br>0010<br>0011<br>0101   | Tie low (1'b0).<br>Overrange bit.<br>Signal monitor bit.<br>Fast detect (FD) bit.<br>SYSREF.  | 0x1   | R/W    |
| 0x0561 | Out sample mode       | [7:3] | Reserved                          |  | Reserved.   | 0x0   | R/W    |
|        |                       | 2     | Sample invert                     | 0<br>1   | ADC sample data is not inverted.<br>ADC sample data is inverted.  | 0x0   | R/W    |
|        |                       | [1:0] | Data format select                | 00<br>01   | Offset binary.<br>Twos complement (default)   | 0x1   | R/W    |
| 0x0562 | Out overrange clear   | [7:0] | Data format overrange clear       | 0<br>1   | Overrange clear bits (one bit for each virtual converter). Writing a 1 to the overrange clear bit clears the corresponding overrange sticky bit.<br>Overrange bit enabled.<br>Overrange bit cleared.  | 0x0   | R/W    |

| Addr.  | Name                         | Bits  | Bit Name                       | Settings                     | Description   | Reset  | Access              |
|--------|------------------------------|-------|--------------------------------|------------------------------|---|--------|---------------------|
| 0x0563 | Out overrange status         | [7:0] | Data format overrange          | 0<br>1                       | Overrange sticky bit status (one bit for each virtual converter). Writing a 1 to the overrange clear bit clears the corresponding overrange sticky bit.<br>No overrange occurred.<br>Overrange occurred.  | 0x0    | R                   |
| 0x0564 | Out channel select           | [7:1] | Reserved                       |                              | Reserved.   | 0x0    | R                   |
|        |                              | 0     | Converter channel swap control | 0<br>1                       | Normal channel ordering.<br>Channel swap enabled.   | 0x0    | R/W                 |
| 0x056E | PLL control                  | [7:4] | JESD204B lane rate control     | 0000<br>0001<br>0011<br>0101 | Lane rate = 6.75 Gbps to 13.5 Gbps.<br>Lane rate = 3.375 Gbps to 6.75 Gbps.<br>Lane rate = 13.5 Gbps to 15.5 Gbps.<br>Lane rate = 1.6875 Gbps to 3.375 Gbps.  | 0x3    | R/W                 |
|        |                              | [3:0] | Reserved                       |                              | Reserved.   | 0x0    | R                   |
| 0x056F | PLL status                   | 7     | PLL lock status                | 0<br>1                       | Not locked.<br>Locked.  | 0x0    | R                   |
|        |                              | [6:4] | Reserved                       |                              | Reserved.   | 0x0    | R                   |
|        |                              | 3     | PLL loss of lock               | 1                            | Loss of lock sticky bit.<br>Indicate a loss of lock has occurred at some time. Cleared by setting Register 0x0571, Bit 0.   |        |                     |
|        |                              | [2:0] | Reserved                       |                              | Reserved  |        |                     |
| 0x0570 | $f_s \times 4$ configuration | [7:0] |                                | 0xFE<br>0xFF                 | See the $f_s \times 4$ Mode section.<br>L = 8, M = 2, F = 2, S = 4, N' = 16, N = 16, CS = 0, CF = 0, HD = 0;<br>$f_s \times 4$ mode enabled.<br>$f_s \times 4$ mode disabled. L, M, and F set by Register 0x058B, Bits[4:0], Register 0x58E, Bits[7:0], and Register 0x058C, Bits[7:0], respectively.   | 0xFF   | R/W                 |
| 0x0571 | JESD204B Link Control 1      | 7     | Standby mode                   | 0<br>1                       | Standby mode forces zeros for all converter samples.<br>Standby mode forces code group synchronization (K28.5 characters).  | 0x0    | R/W                 |
|        |                              |       |                                | 6                            | Tail bit(t) PN  | 0<br>1 | Disable.<br>Enable. |
|        |                              | 5     | Long transport layer test      | 0<br>1                       | JESD204B test samples disabled.<br>JESD204B test samples enabled; long transport layer test sample sequence (as specified in JESD204B Section 5.1.6.3) sent on all link lanes.  | 0x0    | R/W                 |
|        |                              | 4     | Lane synchronization           | 0<br>1                       | Disable FACI uses /K28.7/.<br>Enable FACI uses /K28.3/ and /K28.7/.   | 0x1    | R/W                 |
|        |                              | [3:2] | ILAS sequence mode             | 00<br>01<br>11               | Initial lane alignment sequence disabled (JESD204B Section 5.3.3.5).<br>Initial lane alignment sequence enabled (JESD204B Section 5.3.3.5).<br>Initial lane alignment sequence always on test mode. JESD204B data link layer test mode where repeated lane alignment sequence (as specified in JESD204B Section 5.3.3.8.2) sent on all lanes. | 0x1    | R/W                 |
|        |                              | 1     | FACI                           | 0<br>1                       | Frame alignment character insertion enabled (JESD204B Section 5.3.3.4).<br>Frame alignment character insertion disabled. For debug only (JESD204B Section 5.3.3.4).   | 0x0    | R/W                 |

| Addr.  | Name                    | Bits  | Bit Name                    | Settings   | Description   | Reset | Access |
|--------|-------------------------|-------|-----------------------------|--|---|-------|--------|
|        |                         | 0     | Link control                | 0<br>1   | JESD204B serial transmit link enabled. Transmission of the /K28.5/ characters for code group synchronization is controlled by the SYNC~ signal.<br>JESD204B serial transmit link powered down (held in reset and clock gated).  | 0x0   | R/W    |
| 0x0572 | JESD204B Link Control 2 | [7:6] | SYNCINB± pin control        | 00<br>10<br>11   | Normal mode.<br>Ignore SYNCINB± (force CGS).<br>Ignore SYNCINB± (force ILAS/user data).   | 0x0   | R/W    |
|        |                         | 5     | SYNCINB± pin invert         | 0<br>1   | SYNCINB± pin not inverted.<br>SYNCINB± pin inverted.  | 0x0   | R/W    |
|        |                         | 4     | SYNCINB± pin type           | 0<br>1   | LVDS differential pair SYNC~ input.<br>CMOS single-ended SYNC~ input. SYNCINB+ used.  | 0x0   | R/W    |
|        |                         | 3     | Reserved                    |  | Reserved.   | 0x0   | R      |
|        |                         | 2     | 8-bit/10-bit bypass         | 0<br>1   | 8-bit/10-bit enabled.<br>8-bit/10-bit bypassed (most significant 2 bits are 0).   | 0x0   | R/W    |
|        |                         | 1     | 8-bit/10-bit bit invert     | 0<br>1   | Normal.<br>Invert a, b, c, d, e, f, g, h, l, and j symbols.   | 0x0   | R/W    |
|        |                         | 0     | Reserved                    |  | Reserved.   | 0x0   | R/W    |
| 0x0573 | JESD204B Link Control 3 | [7:6] | Checksum mode               | 00<br>01<br>10<br>11   | Checksum is the sum of all 8-bit registers in the link configuration table.<br>Checksum is the sum of all individual link configuration fields (LSB aligned).<br>Checksum is disabled (set to zero). For test purposes only.<br>Unused.   | 0x0   | R/W    |
|        |                         | [5:4] | Test injection point        | 0<br>1<br>10   | N' sample input.<br>10-bit data at 8-bit/10-bit output (for PHY testing).<br>8-bit data at scrambler input.   | 0x0   | R/W    |
|        |                         | [3:0] | JESD204B test mode patterns | 0<br>1<br>10<br>11<br>100<br>101<br>110<br>111<br>1000<br>1110<br>1111 | Normal operation (test mode disabled).<br>Alternating checkerboard.<br>1/0 word toggle.<br>31-bit pseudorandom number (PN) sequence: $x^{31} + x^{28} + 1$ .<br>23-bit PN sequence: $x^{23} + x^{18} + 1$ .<br>15-bit PN sequence: $x^{15} + x^{14} + 1$ .<br>9-bit PN sequence: $x^9 + x^5 + 1$ .<br>7-bit PN sequence: $x^7 + x^6 + 1$ .<br>Ramp output.<br>Continuous/repeat user test.<br>Single user test. | 0x0   | R/W    |

| Addr.  | Name                        | Bits  | Bit Name                | Settings   | Description  | Reset | Access |
|--------|-----------------------------|-------|-------------------------|--|--|-------|--------|
| 0x0574 | JESD204B Link Control 4     | [7:4] | ILAS delay              | 0<br>1<br>10<br>11<br>100<br>101<br>110<br>111<br>1000<br>1001<br>1010<br>1011<br>1100<br>1101<br>1110<br>1111 | Transmit ILAS on first LMFC after SYNCINB± deasserted.<br>Transmit ILAS on second LMFC after SYNCINB± deasserted.<br>Transmit ILAS on third LMFC after SYNCINB± deasserted.<br>Transmit ILAS on fourth LMFC after SYNCINB± deasserted.<br>Transmit ILAS on fifth LMFC after SYNCINB± deasserted.<br>Transmit ILAS on sixth LMFC after SYNCINB± deasserted.<br>Transmit ILAS on seventh LMFC after SYNCINB± deasserted.<br>Transmit ILAS on eighth LMFC after SYNCINB± deasserted.<br>Transmit ILAS on ninth LMFC after SYNCINB± deasserted.<br>Transmit ILAS on tenth LMFC after SYNCINB± deasserted.<br>Transmit ILAS on eleventh LMFC after SYNCINB± deasserted.<br>Transmit ILAS on twelfth LMFC after SYNCINB± deasserted.<br>Transmit ILAS on thirteenth LMFC after SYNCINB± deasserted.<br>Transmit ILAS on fourteenth LMFC after SYNCINB± deasserted.<br>Transmit ILAS on fifteenth LMFC after SYNCINB± deasserted.<br>Transmit ILAS on sixteenth LMFC after SYNCINB± deasserted. | 0x0   | R/W    |
|        |                             | 3     | Reserved                |  | Reserved.  | 0x0   | R      |
|        |                             | [2:0] | Link layer test mode    | 000<br>001<br>010<br>011<br>100<br>101<br>110<br>111   | Normal operation (link layer test mode disabled).<br>Continuous sequence of /D21.5/ characters.<br>Reserved.<br>Reserved.<br>Modified RPAT test sequence.<br>JSPAT test sequence.<br>JTSPAT test sequence.<br>Reserved.  | 0x0   | R/W    |
| 0x0578 | JESD204B LMFC offset        | [7:5] | Reserved                |  | Reserved.  | 0x0   | R      |
|        |                             | [4:0] | LMFC phase offset value |  | Local multiframe clock (LMFC) phase offset value (in frame clocks). Refer to the Deterministic Latency section.  | 0x0   | R/W    |
| 0x0580 | JESD204B DID configuration  | [7:0] | JESD204B Tx DID value   |  | JESD204B serial device identification (DID) number.  | 0x0   | R/W    |
| 0x0581 | JESD204B BID configuration  | [7:4] | Reserved                |  | Reserved.  | 0x0   | R      |
|        |                             | [3:0] | JESD204B Tx BID value   |  | JESD204B serial bank identification (BID) number (extension to DID).   | 0x0   | R/W    |
| 0x0583 | JESD204B LID0 configuration | [7:5] | Reserved                |  | Reserved.  | 0x0   | R      |
|        |                             | [4:0] | Lane 0 LID value        |  | JESD204B serial lane identification (LID) number for Lane 0.   | 0x0   | R/W    |
| 0x0584 | JESD204B LID1 configuration | [7:5] | Reserved                |  | Reserved.  | 0x0   | R      |
|        |                             | [4:0] | Lane 1 LID value        |  | JESD204B serial lane identification (LID) number for Lane 1.   | 0x1   | R/W    |
| 0x0585 | JESD204B LID2 configuration | [7:5] | Reserved                |  | Reserved.  | 0x0   | R      |
|        |                             | [4:0] | Lane 2 LID value        |  | JESD204B serial lane identification (LID) number for Lane 2.   | 0x2   | R/W    |
| 0x0586 | JESD204B LID3 configuration | [7:5] | Reserved                |  | Reserved.  | 0x0   | R      |
|        |                             | [4:0] | Lane 3 LID value        |  | JESD204B serial lane identification (LID) number for Lane 3.   | 0x3   | R/W    |
| 0x0587 | JESD204B LID4 configuration | [7:5] | Reserved                |  | Reserved.  | 0x0   | R      |
|        |                             | [4:0] | Lane 4 LID value        |  | JESD204B serial lane identification (LID) number for Lane 4.   | 0x4   | R/W    |
| 0x0588 | JESD204B LID5 configuration | [7:5] | Reserved                |  | Reserved.  | 0x0   | R      |
|        |                             | [4:0] | Lane 5 LID value        |  | JESD204B serial lane identification (LID) number for Lane 5.   | 0x5   | R/W    |
| 0x0589 | JESD204B LID6 configuration | [7:5] | Reserved                |  | Reserved.  | 0x0   | R      |
|        |                             | [4:0] | Lane 6 LID value        |  | JESD204B serial lane identification (LID) number for Lane 6.   | 0x6   | R/W    |
| 0x058A | JESD204B LID7 configuration | [7:5] | Reserved                |  | Reserved.  | 0x0   | R      |
|        |                             | [4:0] | Lane 7 LID value        |  | JESD204B serial lane identification (LID) number for Lane 7.   | 0x7   | R/W    |

| Addr.  | Name   | Bits   | Bit Name  | Settings                                 | Description  | Reset | Access  |                     |  |       |  |                    |  |     |           |
|--------|--|--|---|--|--|-------|---|---------------------|--|-------|--|--------------------|--|-----|-----------|
| 0x058B | JESD204B scrambling and number lanes (L) configuration | 7  | JESD204B scrambling (SCR)   | 0<br>1                                   | JESD204B scrambler disabled (SCR = 0).<br>JESD204B scrambler enabled (SCR = 1).  | 0x1   | R/W   |                     |  |       |  |                    |  |     |           |
|        |  | [6:5]  | Reserved  |  | Reserved.  | 0x0   | R   |                     |  |       |  |                    |  |     |           |
|        |  | [4:0]  | JESD204B lanes (L)  | 0x0<br>0x1<br>0x3<br>0x7                 | One lane per link (L = 1).<br>Two lanes per link (L = 2).<br>Four lanes per link (L = 4).<br>Eight lanes per Link (L = 8). | 0x7   | R/W   |                     |  |       |  |                    |  |     |           |
| 0x058C | JESD204B link number of octets per frames (F)          | [7:0]  | JESD204B F configuration  | 0<br>1<br>10<br>11<br>101<br>111<br>1111 | F = 1.<br>F = 2.<br>F = 3.<br>F = 4.<br>F = 6.<br>F = 8.<br>F = 16.  | 0x0   | R/W   |                     |  |       |  |                    |  |     |           |
|        |  |  |   | [7:5]                                    | Reserved   |       | Reserved.   | 0x0                 | R  |       |  |                    |  |     |           |
|        |  |  |   | [4:0]                                    | JESD204B K configuration   |       | JESD204B number of frames per multiframe (K = JESD204B K configuration + 1). Only values where F × K is divisible by 4 can be used. | 0x1F                | R/W  |       |  |                    |  |     |           |
|        |  |  |   | 0x058E                                   | JESD204B link number of converters (M)   | [7:0] | JESD204B M configuration  | 0<br>1<br>11<br>111 | Link connected to one virtual converter (M = 1).<br>Link connected to two virtual converters (M = 2).<br>Link connected to four virtual converters (M = 4).<br>Link connected to eight virtual converters (M = 8). | 0x1   | R/W                                    |                    |  |     |           |
|        |  |  |   |  |  |       |   | 0x058F              | JESD204B number of control bits (CS) and ADC resolution (N)  | [7:6] | Number of control bits (CS) per sample | 0<br>1<br>10<br>11 | No control bits (CS = 0).<br>1 control bit (CS = 1), Control Bit 2 only.<br>2 control bits (CS = 2), Control Bit 2 and Control Bit 1 only.<br>3 control bits (CS = 3), all control bits (Control Bit 2, Control Bit 1, and Control Bit 0). | 0x0 | R/W       |
|        |  |  |   |  |  |       |   |                     |  |       |  | 5                  | Reserved   |     | Reserved. |
| [4:0]  | ADC converter resolution (N)                           | 00110<br>00111<br>01000<br>01001<br>01010<br>01011<br>01100<br>01101<br>01110<br>01111 | N = 7-bit resolution.<br>N = 8-bit resolution.<br>N = 9-bit resolution.<br>N = 10-bit resolution.<br>N = 11-bit resolution.<br>N = 12-bit resolution.<br>N = 13-bit resolution.<br>N = 14-bit resolution.<br>N = 15-bit resolution.<br>N = 16-bit resolution. |  |  |       |   |                     |  |       |  | 0xF                | R/W  |     |           |

| Addr.  | Name                              | Bits  | Bit Name  | Settings                   | Description  | Reset | Access |
|--------|-----------------------------------|-------|---|----------------------------|--|-------|--------|
| 0x0590 | JESD204B SCV NP configuration     | [7:5] | Subclass support                                  | 000<br>001                 | Subclass 0.<br>Subclass 1.   | 0x1   | R/W    |
|        |                                   | [4:0] | ADC number of bits per sample(N')                 | 0 0111<br>0 1011<br>0 1111 | N' = 8.<br>N' = 12.<br>N' = 16.  | 0xF   | R/W    |
| 0x0591 | JESD204B JV S configuration       | [7:5] | Reserved  |                            | Reserved.  | 0x1   | R      |
|        |                                   | [4:0] | Samples per converter frame cycle (S)             |                            | Samples per converter frame cycle (S = Register 0x0591, Bits[4:0] + 1).  | 0x0   | R      |
| 0x0592 | JESD204B HD CF configuration      | 7     | HD value  | 0<br>1                     | High density format disabled.<br>High density format enabled.  | 0x0   | R      |
|        |                                   | [6:5] | Reserved  |                            | Reserved.  | 0x0   | R      |
|        |                                   | [4:0] | Control words per frame clock cycle per link (CF) |                            | Number of control words per frame clock cycle per link (CF = Register 0x0592, Bits[4:0]).  | 0x0   | R      |
| 0x05A0 | JESD204B Checksum 0 configuration | [7:0] | Checksum 0 checksum value for SERDOUT0±           |                            | Serial checksum value for Lane 0. Automatically calculated for each lane. Sum (all link configuration parameters for Lane 0) mod 256.    | 0xC3  | R      |
| 0x05A1 | JESD204B Checksum 1 configuration | [7:0] | Checksum 1 checksum value for SERDOUT1±           |                            | Serial checksum value for Lane 1. Automatically calculated for each lane. Sum (all link configuration parameters for Lane 1) mod 256.    | 0xC4  | R      |
| 0x05A2 | JESD204B Checksum 2 configuration | [7:0] | Checksum 2 checksum value for SERDOUT2±           |                            | Serial checksum value for Lane 2. Automatically calculated for each lane. Sum (all link configuration parameters for each lane) mod 256. | 0xC5  | R      |
| 0x05A3 | JESD204B Checksum 3 configuration | [7:0] | Checksum 3 checksum value for SERDOUT3±           |                            | Serial checksum value for Lane 3. Automatically calculated for each lane. Sum (all link configuration parameters for Lane 3) mod 256.    | 0xC6  | R      |
| 0x05B0 | JESD204B lane power-down          | 7     | JESD204B Lane 7 power-down                        | 0<br>1                     | Physical Lane 7 force power-down.<br>SERDOUT7± normal operation.<br>SERDOUT7± power-down.  | 0x0   | R/W    |
|        |                                   | 6     | JESD204B Lane 6 power-down                        | 0<br>1                     | Physical Lane 6 force power-down.<br>SERDOUT6± normal operation.<br>SERDOUT6± power-down.  | 0x0   | R/W    |
|        |                                   | 5     | JESD204B Lane 5 power-down                        | 0<br>1                     | Physical Lane 5 force power-down.<br>SERDOUT5± normal operation.<br>SERDOUT5± power-down.  | 0x0   | R/W    |
|        |                                   | 4     | JESD204B Lane 4 power-down                        | 0<br>1                     | Physical Lane 4 force power-down.<br>SERDOUT4± normal operation.<br>SERDOUT4± power-down.  | 0x0   | R/W    |
|        |                                   | 3     | JESD204B Lane 3 power-down                        | 0<br>1                     | Physical Lane 3 force power-down.<br>SERDOUT3± normal operation.<br>SERDOUT3± power-down.  | 0x0   | R/W    |
|        |                                   | 2     | JESD204B Lane 2 power-down                        | 0<br>1                     | Physical Lane 2 force power-down.<br>SERDOUT2± normal operation.<br>SERDOUT2± power-down.  | 0x0   | R/W    |
|        |                                   | 1     | JESD204B Lane 1 power-down                        | 0<br>1                     | Physical Lane 1 force power-down.<br>SERDOUT1± normal operation.<br>SERDOUT1± power-down.  | 0x0   | R/W    |
|        |                                   | 0     | JESD204B Lane 0 power-down                        | 0<br>1                     | Physical Lane 0 force power-down.<br>SERDOUT0± normal operation.<br>SERDOUT0± power-down.  | 0x0   | R/W    |

| Addr.  | Name                       | Bits  | Bit Name                    | Settings | Description                 | Reset | Access |
|--------|----------------------------|-------|-----------------------------|----------|-----------------------------|-------|--------|
| 0x05B2 | JESD204B Lane Assign 1     | 7     | Reserved                    |          | Reserved.                   | 0x0   | R      |
|        |                            | [6:4] | SERDOOUT1± lane assignment  |          | Physical Lane 1 assignment. | 0x1   | R/W    |
|        |                            |       |                             | 0        | Logical Lane 0.             |       |        |
|        |                            |       |                             | 1        | Logical Lane 1 (default).   |       |        |
|        |                            |       |                             | 10       | Logical Lane 2.             |       |        |
|        |                            |       |                             | 11       | Logical Lane 3.             |       |        |
| 100    | Logical Lane 4.            |       |                             |          |                             |       |        |
| 101    | Logical Lane 5.            |       |                             |          |                             |       |        |
| 110    | Logical Lane 6.            |       |                             |          |                             |       |        |
| 111    | Logical Lane 7.            |       |                             |          |                             |       |        |
| 3      | Reserved                   |       | Reserved.                   | 0x0      | R                           |       |        |
| [2:0]  | SERDOOUT0± lane assignment |       | Physical Lane 0 assignment. | 0x0      | R/W                         |       |        |
|        |                            | 0     | Logical Lane 0 (default).   |          |                             |       |        |
|        |                            | 1     | Logical Lane 1.             |          |                             |       |        |
|        |                            | 10    | Logical Lane 2.             |          |                             |       |        |
|        |                            | 11    | Logical Lane 3.             |          |                             |       |        |
|        |                            | 100   | Logical Lane 4.             |          |                             |       |        |
|        |                            | 101   | Logical Lane 5.             |          |                             |       |        |
|        |                            | 110   | Logical Lane 6.             |          |                             |       |        |
| 111    | Logical Lane 7.            |       |                             |          |                             |       |        |
| 0x05B3 | JESD204B Lane Assign 2     | 7     | Reserved                    |          | Reserved.                   | 0x0   | R      |
|        |                            | [6:4] | SERDOOUT3± lane assignment  |          | Physical Lane 3 assignment. | 0x3   | R/W    |
|        |                            |       |                             | 0        | Logical Lane 0.             |       |        |
|        |                            |       |                             | 1        | Logical Lane 1.             |       |        |
|        |                            |       |                             | 10       | Logical Lane 2.             |       |        |
|        |                            |       |                             | 11       | Logical Lane 3 (default).   |       |        |
| 100    | Logical Lane 4.            |       |                             |          |                             |       |        |
| 101    | Logical Lane 5.            |       |                             |          |                             |       |        |
| 110    | Logical Lane 6.            |       |                             |          |                             |       |        |
| 111    | Logical Lane 7.            |       |                             |          |                             |       |        |
| 3      | Reserved                   |       | Reserved.                   | 0x0      | R                           |       |        |
| [2:0]  | SERDOOUT2± lane assignment |       | Physical Lane 2 assignment. | 0x2      | R/W                         |       |        |
|        |                            | 0     | Logical Lane 0.             |          |                             |       |        |
|        |                            | 1     | Logical Lane 1              |          |                             |       |        |
|        |                            | 10    | Logical Lane 2 (default).   |          |                             |       |        |
|        |                            | 11    | Logical Lane 3.             |          |                             |       |        |
|        |                            | 100   | Logical Lane 4.             |          |                             |       |        |
|        |                            | 101   | Logical Lane 5.             |          |                             |       |        |
|        |                            | 110   | Logical Lane 6.             |          |                             |       |        |
| 111    | Logical Lane 7.            |       |                             |          |                             |       |        |
| 0x05B5 | JESD204B Lane Assign 3     | 7     | Reserved                    |          | Reserved.                   | 0x0   | R      |
|        |                            | [6:4] | SERDOOUT5± lane assignment  |          | Physical Lane 5 assignment. | 0x5   | R/W    |
|        |                            |       |                             | 0        | Logical Lane 0.             |       |        |
|        |                            |       |                             | 1        | Logical Lane 1.             |       |        |
|        |                            |       |                             | 10       | Logical Lane 2.             |       |        |
|        |                            |       |                             | 11       | Logical Lane 3.             |       |        |
| 100    | Logical Lane 4.            |       |                             |          |                             |       |        |
| 101    | Logical Lane 5 (default).  |       |                             |          |                             |       |        |
| 110    | Logical Lane 6.            |       |                             |          |                             |       |        |
| 111    | Logical Lane 7.            |       |                             |          |                             |       |        |
| 3      | Reserved                   |       | Reserved.                   | 0x0      | R                           |       |        |

| Addr.  | Name                   | Bits  | Bit Name                  | Settings                                       | Description   | Reset | Access |
|--------|------------------------|-------|---------------------------|--|---|-------|--------|
|        |                        | [2:0] | SERDOUT4± lane assignment | 0<br>1<br>10<br>11<br>100<br>101<br>110<br>111 | Physical Lane 4 assignment.<br><br>Logical Lane 0.<br>Logical Lane 1.<br>Logical Lane 2.<br>Logical Lane 3.<br>Logical Lane 4 (default).<br>Logical Lane 5.<br>Logical Lane 6.<br>Logical Lane 7. | 0x4   | R/W    |
| 0x05B6 | JESD204B Lane Assign 4 | 7     | Reserved                  |  | Reserved.   | 0x0   | R      |
|        |                        | [6:4] | SERDOUT7± lane assignment | 0<br>1<br>10<br>11<br>100<br>101<br>110<br>111 | Physical Lane 7 assignment.<br><br>Logical Lane 0.<br>Logical Lane 1.<br>Logical Lane 2.<br>Logical Lane 3.<br>Logical Lane 4.<br>Logical Lane 5.<br>Logical Lane 6.<br>Logical Lane 7 (default). | 0x7   | R/W    |
|        |                        | 3     | Reserved                  |  | Reserved.   | 0x0   | R      |
|        |                        | [2:0] | SERDOUT6± lane assignment | 0<br>1<br>10<br>11<br>100<br>101<br>110<br>111 | Physical Lane 6 assignment.<br><br>Logical Lane 0.<br>Logical Lane 1.<br>Logical Lane 2.<br>Logical Lane 3.<br>Logical Lane 4.<br>Logical Lane 5.<br>Logical Lane 6 (default).<br>Logical Lane 7. | 0x6   | R/W    |
| 0x05BF | SERDOUTx± data invert  | 7     | Invert SERDOUT7± data     | 0  | Invert SERDOUT7± data.  | 0x0   | R/W    |
|        |                        |       |                           | 1  | Normal.   |       |        |
|        |                        | 6     | Invert SERDOUT6± data     | 0  | Invert SERDOUT6± data.  | 0x0   | R/W    |
|        |                        |       |                           | 1  | Normal.   |       |        |
|        |                        | 5     | Invert SERDOUT5± data     | 0  | Invert SERDOUT5± data.  | 0x0   | R/W    |
|        |                        |       |                           | 1  | Normal.   |       |        |
|        |                        | 4     | Invert SERDOUT4± data     | 0  | Invert SERDOUT4± data.  | 0x0   | R/W    |
|        |                        |       |                           | 1  | Normal.   |       |        |
| 3      | Invert SERDOUT3± data  | 0     | Invert SERDOUT3± data.    | 0x0  | R/W   |       |        |
|        |                        | 1     | Normal.                   |  |   |       |        |
| 2      | Invert SERDOUT2± data  | 0     | Invert SERDOUT2± data.    | 0x0  | R/W   |       |        |
|        |                        | 1     | Normal.                   |  |   |       |        |
| 1      | Invert SERDOUT1± data  | 0     | Invert SERDOUT1± data.    | 0x0  | R/W   |       |        |
|        |                        | 1     | Normal.                   |  |   |       |        |
| 0      | Invert SERDOUT0± data  | 0     | Invert SERDOUT0± data.    | 0x0  | R/W   |       |        |
|        |                        | 1     | Normal.                   |  |   |       |        |



| Addr.  | Name                    | Bits  | Bit Name                        | Settings | Description                        | Reset | Access |  |
|--------|-------------------------|-------|---------------------------------|----------|------------------------------------|-------|--------|--|
| 0x05C0 | JESD204B Swing Adjust 1 | 7     | Reserved                        |          | Reserved.                          | 0x0   | R      |  |
|        |                         | [6:4] | SERDOOUT1± voltage swing adjust |          | Output swing level for SERDOOUT1±. | 0x1   | R/W    |  |
|        |                         |       |                                 | 000      | 1.0 × DRVDD1.                      |       |        |  |
|        |                         |       |                                 | 001      | 0.850 × DRVDD1.                    |       |        |  |
|        |                         |       |                                 | 010      | 0.750 × DRVDD1.                    |       |        |  |
| 0x05C1 | JESD204B Swing Adjust 2 | 7     | Reserved                        |          | Reserved.                          | 0x0   | R      |  |
|        |                         | [6:4] | SERDOOUT3± voltage swing adjust |          | Output swing level for SERDOOUT3±. | 0x1   | R/W    |  |
|        |                         |       |                                 | 000      | 1.0 × DRVDD1.                      |       |        |  |
|        |                         |       |                                 | 001      | 0.850 × DRVDD1.                    |       |        |  |
|        |                         |       |                                 | 010      | 0.750 × DRVDD1.                    |       |        |  |
| 0x05C2 | JESD204B Swing Adjust 3 | 7     | Reserved                        |          | Reserved.                          | 0x0   | R      |  |
|        |                         | [6:4] | SERDOOUT5± voltage swing adjust |          | Output swing level for SERDOOUT5±. | 0x1   | R/W    |  |
|        |                         |       |                                 | 000      | 1.0 × DRVDD1.                      |       |        |  |
|        |                         |       |                                 | 001      | 0.850 × DRVDD1.                    |       |        |  |
|        |                         |       |                                 | 010      | 0.750 × DRVDD1.                    |       |        |  |
| 0x05C3 | JESD204B Swing Adjust 4 | 7     | Reserved                        |          | Reserved.                          | 0x0   | R      |  |
|        |                         | [6:4] | SERDOOUT7± voltage swing adjust |          | Output swing level for SERDOOUT7±. | 0x1   | R/W    |  |
|        |                         |       |                                 | 000      | 1.0 × DRVDD1.                      |       |        |  |
|        |                         |       |                                 | 001      | 0.850 × DRVDD1.                    |       |        |  |
|        |                         |       |                                 | 010      | 0.750 × DRVDD1.                    |       |        |  |
| 0x05C3 | JESD204B Swing Adjust 4 | 3     | Reserved                        |          | Reserved.                          | 0x0   | R      |  |
|        |                         | [2:0] | SERDOOUT6± voltage swing adjust |          | Output swing level for SERDOOUT6±. | 0x1   | R/W    |  |
|        |                         |       |                                 | 000      | 1.0 × DRVDD1.                      |       |        |  |
|        |                         |       |                                 | 001      | 0.850 × DRVDD1.                    |       |        |  |
|        |                         |       |                                 | 010      | 0.750 × DRVDD1.                    |       |        |  |

| Addr.  | Name                         | Bits  | Bit Name                         | Settings | Description | Reset | Access |
|--------|------------------------------|-------|----------------------------------|----------|-------------|-------|--------|
| 0x05C4 | SERDOUT0 pre-emphasis select | 7     | Post tap enable                  | 0        | Disable.    | 0x0   | R/W    |
|        |                              |       |                                  | 1        | Enable.     |       |        |
|        |                              | [6:4] | Set post tap level for SERDOUT0± | 000      | 0 dB.       | 0x0   | R/W    |
|        |                              | 001   | 3 dB.                            |          |             |       |        |
| 010    | 6 dB.                        |       |                                  |          |             |       |        |
| 011    | 9 dB.                        |       |                                  |          |             |       |        |
| [3:0]  | Reserved                     |       | Reserved.                        |          |             |       |        |
| 0x05C5 | SERDOUT1 pre-emphasis select | 7     | Post tap enable                  | 0        | Disable.    | 0x0   | R/W    |
|        |                              |       |                                  | 1        | Enable.     |       |        |
|        |                              | [6:4] | Set post tap level for SERDOUT1± | 000      | 0 dB.       | 0x0   | R/W    |
|        |                              | 001   | 3 dB.                            |          |             |       |        |
| 010    | 6 dB.                        |       |                                  |          |             |       |        |
| 011    | 9 dB.                        |       |                                  |          |             |       |        |
| [3:0]  | Reserved                     |       | Reserved.                        |          |             |       |        |
| 0x05C6 | SERDOUT2 pre-emphasis select | 7     | Post tap enable                  | 0        | Disable.    | 0x0   | R/W    |
|        |                              |       |                                  | 1        | Enable.     |       |        |
|        |                              | [6:4] | Set post tap level for SERDOUT2± | 000      | 0 dB.       | 0x0   | R/W    |
|        |                              | 001   | 3 dB.                            |          |             |       |        |
| 010    | 6 dB.                        |       |                                  |          |             |       |        |
| 011    | 9 dB.                        |       |                                  |          |             |       |        |
| [3:0]  | Reserved                     |       | Reserved.                        |          |             |       |        |
| 0x05C7 | SERDOUT3 pre-emphasis select | 7     | Post tap enable                  | 0        | Disable.    | 0x0   | R/W    |
|        |                              |       |                                  | 1        | Enable.     |       |        |
|        |                              | [6:4] | Set post tap level for SERDOUT3± | 000      | 0 dB.       | 0x0   | R/W    |
|        |                              | 001   | 3 dB.                            |          |             |       |        |
| 010    | 6 dB.                        |       |                                  |          |             |       |        |
| 011    | 9 dB.                        |       |                                  |          |             |       |        |
| [3:0]  | Reserved                     |       | Reserved.                        |          |             |       |        |
| 0x05C8 | SERDOUT4 pre-emphasis select | 7     | Post tap enable                  | 0        | Disable.    | 0x0   | R/W    |
|        |                              |       |                                  | 1        | Enable.     |       |        |
|        |                              | [6:4] | Set post tap level for SERDOUT4± | 000      | 0 dB.       | 0x0   | R/W    |
|        |                              | 001   | 3 dB.                            |          |             |       |        |
| 010    | 6 dB.                        |       |                                  |          |             |       |        |
| 011    | 9 dB.                        |       |                                  |          |             |       |        |
| [3:0]  | Reserved                     |       | Reserved.                        |          |             |       |        |

| Addr.  | Name                          | Bits  | Bit Name                         | Settings | Description                                    | Reset | Access |
|--------|-------------------------------|-------|----------------------------------|----------|--|-------|--------|
| 0x05C9 | SERDOUT5 pre-emphasis select  | 7     | Post tap enable                  |          | Post tap enable.                               | 0x0   | R/W    |
|        |                               |       |                                  | 0        | Disable.                                       |       |        |
|        |                               | 1     | Enable.                          |          |  |       |        |
|        |                               | [6:4] | Set post tap level for SERDOUT5± |          | Set post tap level.                            | 0x0   | R/W    |
|        |                               |       |                                  | 000      | 0 dB.  |       |        |
|        |                               |       |                                  | 001      | 3 dB.  |       |        |
|        |                               |       |                                  | 010      | 6 dB.  |       |        |
|        |                               |       |                                  | 011      | 9 dB.  |       |        |
|        |                               |       |                                  | 100      | 12 dB.   |       |        |
|        |                               | [3:0] | Reserved                         |          | Reserved.                                      | 0x0   | R/W    |
| 0x05CA | SERDOUT6 pre-emphasis select  | 7     | Post tap enable                  |          | Post tap enable.                               | 0x0   | R/W    |
|        |                               |       |                                  | 0        | Disable.                                       |       |        |
|        |                               | 1     | Enable.                          |          |  |       |        |
|        |                               | [6:4] | Set post tap level for SERDOUT6± |          | Set post tap level.                            | 0x0   | R/W    |
|        |                               |       |                                  | 000      | 0 dB.  |       |        |
|        |                               |       |                                  | 001      | 3 dB.  |       |        |
|        |                               |       |                                  | 010      | 6 dB.  |       |        |
|        |                               |       |                                  | 011      | 9 dB.  |       |        |
|        |                               |       |                                  | 100      | 12 dB.   |       |        |
|        |                               | [3:0] | Reserved                         |          | Reserved.                                      | 0x0   | R/W    |
| 0x05CB | SERDOUT7 pre-emphasis select  | 7     | Post tap enable                  |          | Post tap enable.                               | 0x0   | R/W    |
|        |                               |       |                                  | 0        | Disable  |       |        |
|        |                               | 1     | Enable                           |          |  |       |        |
|        |                               | [6:4] | Set post tap level for SERDOUT7± |          | Set post tap level.                            | 0x0   | R/W    |
|        |                               |       |                                  | 000      | 0 dB.  |       |        |
|        |                               |       |                                  | 001      | 3 dB.  |       |        |
|        |                               |       |                                  | 010      | 6 dB.  |       |        |
|        |                               |       |                                  | 011      | 9 dB.  |       |        |
|        |                               |       |                                  | 100      | 12 dB.   |       |        |
|        |                               | [3:0] | Reserved                         |          | Reserved.                                      | 0x0   | R/W    |
| 0x1222 | JESD204B PLL calibration      | [7:0] |                                  |          | See Table 32.                                  | 0x00  | R/W    |
|        |                               |       |                                  | 0x00     | JESD204B PLL Normal Operation                  |       |        |
|        |                               |       |                                  | 0x04     | Reset JESD204B PLL calibration                 |       |        |
| 0x1228 | JESD204B PLL start-up control | [7:0] |                                  |          | See Table 32.                                  | 0x0F  | R/W    |
|        |                               |       |                                  | 0x0F     | JESD204B start-up circuit in normal operation. |       |        |
|        |                               |       |                                  | 0x4F     | Reset JESD204B start-up circuit.               |       |        |
| 0x1262 | JESD204B PLL LOL bit control  | [7:0] |                                  |          | See Table 32.                                  | 0x00  | R/W    |
|        |                               |       |                                  | 0x00     | Loss of lock bit normal operation.             |       |        |
|        |                               |       |                                  | 0x80     | Clear loss of lock bit.                        |       |        |

| Addr.  | Name                   | Bits  | Bit Name               | Settings  | Description  | Reset | Access |
|--|------------------------|-------|------------------------|---|--|-------|--------|
| Programmable Filter Control and Coefficients Registers |                        |       |                        |   |  |       |        |
| 0x0DF8   | PFILT control          | [7:3] | Reserved               |   | Reserved.  | 0x0   | R      |
|  |                        | [2:0] | PFILT mode             |   | Programmable filter (PFILT) mode.<br>000 = disabled (filters bypassed).<br>001 = single filter (X only).<br>$DOUT\_I[n] = DIN\_I[n] * X\_I[n]$ .<br>$DOUT\_Q[n] = DIN\_Q[n] * X\_Q[n]$ .<br>010 = single filter (X and Y together).<br>$DOUT\_I[n] = DIN\_I[n] * XY\_I[n]$ .<br>$DOUT\_Q[n] = DIN\_Q[n] * XY\_Q[n]$ .<br>100 = cascaded filters (X to Y).<br>$DOUT\_I[n] = DIN\_I[n] * X\_I[n] * Y\_I[n]$ .<br>$DOUT\_Q[n] = DIN\_Q[n] * X\_Q[n] * Y\_Q[n]$ .<br>$DOUT\_Q[n] = DIN\_Q[n] * X\_Q[n] * Y\_Q[n]$ .<br>101 = complex filters.<br>$DOUT\_I[n] = DIN\_I[n] * X\_I[n] + DIN\_Q[n] * Y\_Q[n]$ .<br>$DOUT\_Q[n] = DIN\_Q[n] * X\_Q[n] + DIN\_I[n] * Y\_I[n]$ .<br>110 = half complex filter.<br>$DOUT\_I[n] = DIN\_I[n]$ .<br>$DOUT\_Q[n] = DIN\_Q[n] * XY\_Q[n] + DIN\_I[n] * XY\_I[n]$ .<br>111 = real 96-tap filter.<br>$DOUT\_I[n] = DIN\_I[n] * XY\_I[n]$ .<br>$DOUT\_Q[n] = DIN\_Q[n] * XY\_Q[n]$ . | 0x0   | R/W    |
| 0x0DF9   | PFILT gain             | 7     | Reserved               |   | Reserved.  | 0x0   | R      |
|  |                        | [6:4] | PFILT Y gain           | 110<br>-12 dB loss.<br>111<br>-6 dB loss.<br>000<br>0 dB gain.<br>001<br>+6 dB gain.<br>010<br>+12 dB gain. | PFILT Y gain.<br>-12 dB loss.<br>-6 dB loss.<br>0 dB gain.<br>+6 dB gain.<br>+12 dB gain.  | 0x0   | R/W    |
|  |                        | 3     | Reserved               |   | Reserved.  | 0x0   | R      |
|  |                        | [2:0] | PFILT X gain           | 110<br>-12 dB loss.<br>111<br>-6 dB loss.<br>000<br>0 dB gain.<br>001<br>+6 dB gain.<br>010<br>+12 dB gain. | PFILT X gain.<br>-12 dB loss.<br>-6 dB loss.<br>0 dB gain.<br>+6 dB gain.<br>+12 dB gain.  | 0x0   | R/W    |
| 0x0E00   | PFILT X Coefficient 0  | [7:0] | PFILT X Coefficient 0  |   | Programmable Filter X coefficients. Coefficients are only applied after the chip transfer bit is written.  | 0x0   | R/W    |
| 0x0E01   | PFILT X Coefficient 1  | [7:0] | PFILT X Coefficient 1  |   | Programmable Filter X coefficients. Coefficients are only applied after the chip transfer bit is written.  | 0x0   | R/W    |
| 0x0E02   | PFILT X Coefficient 2  | [7:0] | PFILT X Coefficient 2  |   | Programmable Filter X coefficients. Coefficients are only applied after the chip transfer bit is written.  | 0x0   | R/W    |
| 0x0E03   | PFILT X Coefficient 3  | [7:0] | PFILT X Coefficient 3  |   | Programmable Filter X coefficients. Coefficients are only applied after the chip transfer bit is written.  | 0x0   | R/W    |
| 0x0E04   | PFILT X Coefficient 4  | [7:0] | PFILT X Coefficient 4  |   | Programmable Filter X coefficients. Coefficients are only applied after the chip transfer bit is written.  | 0x0   | R/W    |
| 0x0E05   | PFILT X Coefficient 5  | [7:0] | PFILT X Coefficient 5  |   | Programmable Filter X coefficients. Coefficients are only applied after the chip transfer bit is written.  | 0x0   | R/W    |
| 0x0E06   | PFILT X Coefficient 6  | [7:0] | PFILT X Coefficient 6  |   | Programmable Filter X coefficients. Coefficients are only applied after the chip transfer bit is written.  | 0x0   | R/W    |
| 0x0E07   | PFILT X Coefficient 7  | [7:0] | PFILT X Coefficient 7  |   | Programmable Filter X coefficients. Coefficients are only applied after the chip transfer bit is written.  | 0x0   | R/W    |
| 0x0E08   | PFILT X Coefficient 8  | [7:0] | PFILT X Coefficient 8  |   | Programmable Filter X coefficients. Coefficients are only applied after the chip transfer bit is written.  | 0x0   | R/W    |
| 0x0E09   | PFILT X Coefficient 9  | [7:0] | PFILT X Coefficient 9  |   | Programmable Filter X coefficients. Coefficients are only applied after the chip transfer bit is written.  | 0x0   | R/W    |
| 0x0E0A   | PFILT X Coefficient 10 | [7:0] | PFILT X Coefficient 10 |   | Programmable Filter X coefficients. Coefficients are only applied after the chip transfer bit is written.  | 0x0   | R/W    |
| 0x0E0B   | PFILT X Coefficient 11 | [7:0] | PFILT X Coefficient 11 |   | Programmable Filter X coefficients. Coefficients are only applied after the chip transfer bit is written.  | 0x0   | R/W    |

















| Addr.                               | Name                                  | Bits  | Bit Name                      | Settings     | Description   | Reset | Access |
|-------------------------------------|---------------------------------------|-------|-------------------------------|--------------|---|-------|--------|
| 0x0F6C                              | PFILT Y Coefficient 108               | [7:0] | PFILT Y Coefficient 108       |              | Programmable Filter Y coefficients. Coefficients are only applied after the chip transfer bit is written. | 0x0   | R/W    |
| 0x0F6D                              | PFILT Y Coefficient 109               | [7:0] | PFILT Y Coefficient 109       |              | Programmable Filter Y coefficients. Coefficients are only applied after the chip transfer bit is written. | 0x0   | R/W    |
| 0x0F6E                              | PFILT Y Coefficient 110               | [7:0] | PFILT Y Coefficient 110       |              | Programmable Filter Y coefficients. Coefficients are only applied after the chip transfer bit is written. | 0x0   | R/W    |
| 0x0F6F                              | PFILT Y Coefficient 111               | [7:0] | PFILT Y Coefficient 111       |              | Programmable Filter Y coefficients. Coefficients are only applied after the chip transfer bit is written. | 0x0   | R/W    |
| 0x0F70                              | PFILT Y Coefficient 112               | [7:0] | PFILT Y Coefficient 112       |              | Programmable Filter Y coefficients. Coefficients are only applied after the chip transfer bit is written. | 0x0   | R/W    |
| 0x0F71                              | PFILT Y Coefficient 113               | [7:0] | PFILT Y Coefficient 113       |              | Programmable Filter Y coefficients. Coefficients are only applied after the chip transfer bit is written. | 0x0   | R/W    |
| 0x0F72                              | PFILT Y Coefficient 114               | [7:0] | PFILT Y Coefficient 114       |              | Programmable Filter Y coefficients. Coefficients are only applied after the chip transfer bit is written. | 0x0   | R/W    |
| 0x0F73                              | PFILT Y Coefficient 115               | [7:0] | PFILT Y Coefficient 115       |              | Programmable Filter Y coefficients. Coefficients are only applied after the chip transfer bit is written. | 0x0   | R/W    |
| 0x0F74                              | PFILT Y Coefficient 116               | [7:0] | PFILT Y Coefficient 116       |              | Programmable Filter Y coefficients. Coefficients are only applied after the chip transfer bit is written. | 0x0   | R/W    |
| 0x0F75                              | PFILT Y Coefficient 117               | [7:0] | PFILT Y Coefficient 117       |              | Programmable Filter Y coefficients. Coefficients are only applied after the chip transfer bit is written. | 0x0   | R/W    |
| 0x0F76                              | PFILT Y Coefficient 118               | [7:0] | PFILT Y Coefficient 118       |              | Programmable Filter Y coefficients. Coefficients are only applied after the chip transfer bit is written. | 0x0   | R/W    |
| 0x0F77                              | PFILT Y Coefficient 119               | [7:0] | PFILT Y Coefficient 119       |              | Programmable Filter Y coefficients. Coefficients are only applied after the chip transfer bit is written. | 0x0   | R/W    |
| 0x0F78                              | PFILT Y Coefficient 120               | [7:0] | PFILT Y Coefficient 120       |              | Programmable Filter Y coefficients. Coefficients are only applied after the chip transfer bit is written. | 0x0   | R/W    |
| 0x0F79                              | PFILT Y Coefficient 121               | [7:0] | PFILT Y Coefficient 121       |              | Programmable Filter Y coefficients. Coefficients are only applied after the chip transfer bit is written. | 0x0   | R/W    |
| 0x0F7A                              | PFILT Y Coefficient 122               | [7:0] | PFILT Y Coefficient 122       |              | Programmable Filter Y coefficients. Coefficients are only applied after the chip transfer bit is written. | 0x0   | R/W    |
| 0x0F7B                              | PFILT Y Coefficient 123               | [7:0] | PFILT Y Coefficient 123       |              | Programmable Filter Y coefficients. Coefficients are only applied after the chip transfer bit is written. | 0x0   | R/W    |
| 0x0F7C                              | PFILT Y Coefficient 124               | [7:0] | PFILT Y Coefficient 124       |              | Programmable Filter Y coefficients. Coefficients are only applied after the chip transfer bit is written. | 0x0   | R/W    |
| 0x0F7D                              | PFILT Y Coefficient 125               | [7:0] | PFILT Y Coefficient 125       |              | Programmable Filter Y coefficients. Coefficients are only applied after the chip transfer bit is written. | 0x0   | R/W    |
| 0x0F7E                              | PFILT Y Coefficient 126               | [7:0] | PFILT Y Coefficient 126       |              | Programmable Filter Y coefficients. Coefficients are only applied after the chip transfer bit is written. | 0x0   | R/W    |
| 0x0F7F                              | PFILT Y Coefficient 127               | [7:0] | PFILT Y Coefficient 127       |              | Programmable Filter Y coefficients. Coefficients are only applied after the chip transfer bit is written. | 0x0   | R/W    |
| VREF/Analog Input Control Registers |                                       |       |                               |              |   |       |        |
| 0x0701                              | DC offset calibration control (local) | [7:0] | DC offset calibration control | 0x06<br>0x86 | Disable.<br>Enable.   | 0x06  | R/W    |
| 0x18A6                              | VREF control                          | [7:1] | Reserved                      |              | Reserved.   | 0x0   | R      |
|                                     |                                       | 0     | VREF control                  | 0<br>1       | Internal reference.<br>External reference.  | 0x0   | R/W    |
| 0x18E3                              | External VCM buffer control           | 7     | Reserved                      |              | Reserved.   | 0x0   | R      |
|                                     |                                       | 6     | External VCM buffer           | 0<br>1       | Disable.<br>Enable.   | 0x0   | R/W    |
|                                     |                                       | [5:0] | External VCM buffer [5:0]     |              | See the Input Common Mode section.  | 0x0   | R/W    |

| Addr.   | Name  | Bits    | Bit Name                          | Settings                 | Description   | Reset | Access |  |      |     |
|---------|---|---------|-----------------------------------|--------------------------|---|-------|--------|--|------|-----|
| 0x18E6  | Temperature diode export                              | [7:0]   | Temperature diode location select |                          | See the Temperature Diode section.                    | 0x0   | R/W    |  |      |     |
|         |   |         |                                   | 0x00                     | Central diode. VREF pin = high-Z.                     |       |        |  |      |     |
|         |   |         |                                   | 0x01                     | Central diode. VREF pin = 1× diode voltage output.    |       |        |  |      |     |
|         |   |         |                                   | 0x02                     | Central diode. VREF pin = 20× diode voltage output.   |       |        |  |      |     |
|         |   |         |                                   | 0x03                     | Central diode. VREF pin = GND.                        |       |        |  |      |     |
|         |   |         |                                   | 0x40                     | Channel A diode. VREF pin = high-Z.                   |       |        |  |      |     |
|         |   |         |                                   | 0x41                     | Channel A diode. VREF pin = 1× diode voltage output.  |       |        |  |      |     |
|         |   |         |                                   | 0x42                     | Channel A diode. VREF pin = 20× diode voltage output. |       |        |  |      |     |
|         |   |         |                                   | 0x43                     | Channel A diode. VREF pin = GND.                      |       |        |  |      |     |
|         |   |         |                                   | 0x50                     | Channel B diode. VREF pin = high-Z.                   |       |        |  |      |     |
| 0x51    | Channel B diode. VREF pin = 1× diode voltage output.  |         |                                   |                          |   |       |        |  |      |     |
| 0x52    | Channel B diode. VREF pin = 20× diode voltage output. |         |                                   |                          |   |       |        |  |      |     |
| 0x53    | Channel B diode. VREF pin = GND.                      |         |                                   |                          |   |       |        |  |      |     |
| 0x1908  | Analog input control (local)                          | [7:3]   | Reserved                          |                          | Reserved.   | 0x0   | R      |  |      |     |
|         |   |         | 2                                 | Enable dc coupling       | 0   |       |        | Analog input is optimized for ac coupling.   | 0x0  | R/W |
|         |   | [1:0]   | Reserved                          |                          | Reserved.   | 0x0   | R      |  |      |     |
| 0x1910  | Input full-scale control (local)                      | [7:4]   | Reserved                          |                          | Reserved.   | 0x0   | R      |  |      |     |
|         |   |         | [3:0]                             | Input full-scale voltage |   |       |        | Full-scale voltage setting.  | 0xD  | R/W |
|         |   |         |                                   |                          | 1000  |       |        | 1.13 V p-p differential.   |      |     |
|         |   |         |                                   |                          | 1001  |       |        | 1.25 V p-p differential.   |      |     |
|         |   |         |                                   |                          | 1101  |       |        | 1.7 V p-p differential.  |      |     |
|         |   |         |                                   |                          | 1110  |       |        | 1.81 V p-p differential.   |      |     |
| 1111    | 1.93 V p-p differential.                              |         |                                   |                          |   |       |        |  |      |     |
| 0000    | 2.04 V p-p differential.                              |         |                                   |                          |   |       |        |  |      |     |
| 0x1A4C  | Buffer Control 1 (local)                              | [7:6]   | Reserved                          |                          | Reserved.   | 0x0   | R      |  |      |     |
|         |   |         | [5:0]                             | Buffer Control 1         |   |       |        | Input Buffer Main Current 1. See the Analog Input Buffer Controls and SFDR Optimization section. | 0x19 | R/W |
|         |   | 00 0100 |                                   |                          | Buffer current set to 400 μA.                         |       |        |  |      |     |
| 00 1001 | Buffer current set to 500 μA.                         |         |                                   |                          |   |       |        |  |      |     |
| 01 1110 | Buffer current set to 600 μA.                         |         |                                   |                          |   |       |        |  |      |     |
| 10 0011 | Buffer current set to 700 μA.                         |         |                                   |                          |   |       |        |  |      |     |
| 10 1000 | Buffer current set to 800 μA.                         |         |                                   |                          |   |       |        |  |      |     |
| 11 0010 | Buffer current set to 1000 μA.                        |         |                                   |                          |   |       |        |  |      |     |
| 0x1A4D  | Buffer Control 2 (local)                              | [7:6]   | Reserved                          |                          | Reserved.   | 0x0   | R      |  |      |     |
|         |   |         | [5:0]                             | Buffer Control 2         |   |       |        | Input Buffer Main Current 2. See the Analog Input Buffer Controls and SFDR Optimization section. | 0x19 | R/W |
|         |   | 00 0100 |                                   |                          | Buffer current set to 400 μA.                         |       |        |  |      |     |
| 00 1001 | Buffer current set to 500 μA.                         |         |                                   |                          |   |       |        |  |      |     |
| 01 1110 | Buffer current set to 600 μA.                         |         |                                   |                          |   |       |        |  |      |     |
| 10 0011 | Buffer current set to 700 μA.                         |         |                                   |                          |   |       |        |  |      |     |
| 10 1000 | Buffer current set to 800 μA.                         |         |                                   |                          |   |       |        |  |      |     |
| 11 0010 | Buffer current set to 1000 μA.                        |         |                                   |                          |   |       |        |  |      |     |

# APPLICATIONS INFORMATION

## POWER SUPPLY RECOMMENDATIONS

The power supplies needed to power the AD9208 are shown in Table 47. A power-on sequence is not required to operate the AD9208. The power supply domains can be powered up in any order.

Table 47. Typical Power Supplies for the AD9208

| Domain   | Voltage (V) | Tolerance (%) |
|----------|-------------|---------------|
| AVDD1    | 0.975       | ±2.5          |
| AVDD1_SR | 0.975       | ±2.5          |
| DVDD     | 0.975       | ±2.5          |
| DRVDD1   | 0.975       | ±2.5          |
| AVDD2    | 1.9         | ±2.5          |
| DRVDD2   | 1.9         | ±2.5          |
| SPIVDD   | 1.9         | ±2.5          |
| AVDD3    | 2.5         | ±2.5          |

For applications requiring an optimal high power efficiency and low noise performance, it is recommended that the ADP5054 quad switching regulator be used to convert an input voltage in the 6.0 V to 15 V range to intermediate rails (1.3 V, 2.4 V, and 3.0 V). These intermediate rails are then postregulated by very low noise, low dropout (LDO) regulators (ADP1763, ADP7159, and ADP151). Figure 131 shows the recommended power supply scheme for the AD9208.

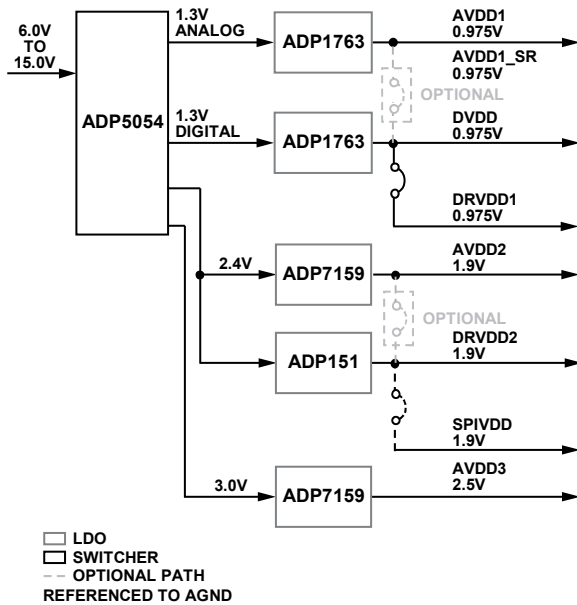

Figure 131. High Efficiency, Low Noise Power Solution for the AD9208

It is not necessary to split all of these power domains in all cases. The recommended solution shown in Figure 131 provides the lowest noise, highest efficiency power delivery system for the AD9208. If only one 0.975 V supply is available, route to AVDD1 first and then tap it off and isolate it with a ferrite bead or a filter choke, preceded by decoupling capacitors for AVDD1\_SR, DVDD, and DRVDD1, in that order. Figure 132 shows the simplified schematic. The dc resistance (DCR) of the ferrite bead must be taken into consideration when choosing the appropriate ferrite bead. Otherwise, excessive loss across the ferrite bead can lead to a malfunctioning ADC. Adjustable LDOs can be employed to output a higher voltage to account for the drop across the ferrite bead.

Alternatively, the LDOs can be bypassed altogether and the AD9208 can be driven directly from the dc-to-dc converter. Note that this approach has risks in that there may be more power supply noise injected into the power supply domains of the ADC. To minimize noise, follow the layout guidelines of the dc-to-dc converter.

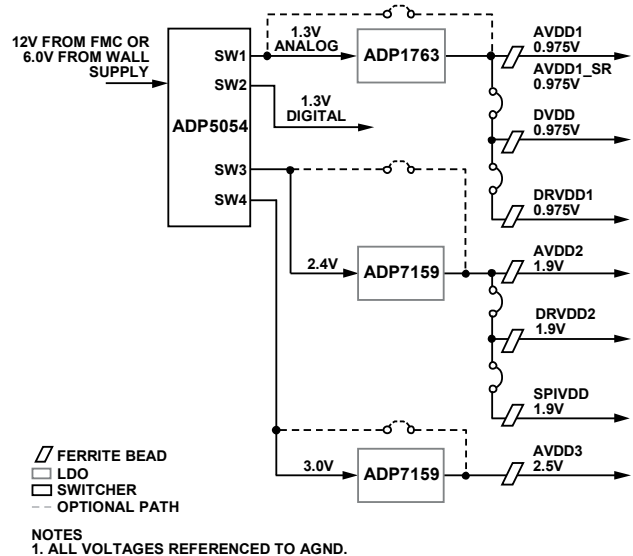

Figure 132. Simplified Power Solution for the AD9208

The user can employ several different decoupling capacitors to cover both high and low frequencies. These capacitors must be located close to the point of entry at the PCB level and close to the devices, with minimal trace lengths.

## LAYOUT GUIDELINES

The ADC evaluation board can be used as a guide to follow good layout practices. The evaluation board layout is set up in such a way as to

- Minimize coupling between the analog inputs (Channel A to Channel B and Channel B to Channel A).
- Minimize clock coupling to the analog inputs.
- Provide enough power and ground planes for the various supply domains while reducing cross coupling.
- Provide adequate thermal relief to the ADC.

Figure 133 shows the overall layout scheme used for the [AD9208](#) evaluation board.

## AVDD1\_SR (PIN E7) AND AGND (PIN E6 AND PIN E8)

AVDD1\_SR (Pin E7) and AGND (Pin E6 and Pin E8) can be used to provide a separate power supply node to the SYSREF± circuits of the [AD9208](#). If running in Subclass 1, the [AD9208](#) can support periodic one-shot or gapped signals. To minimize the coupling of this supply into the AVDD1 supply node, adequate supply bypassing is needed.

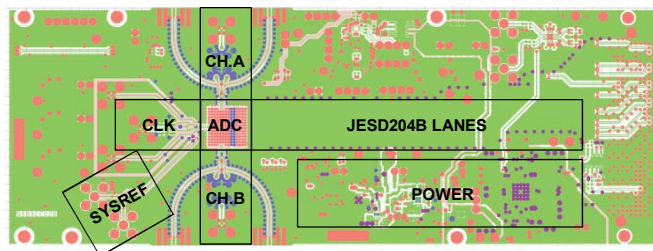
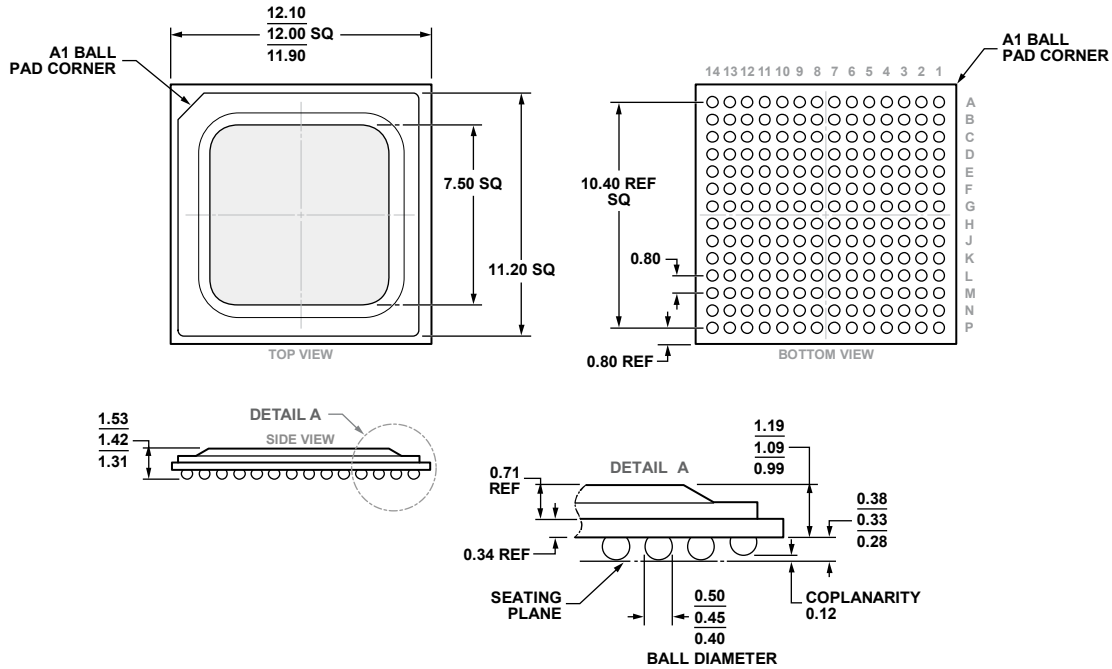

Figure 133. Recommended PCB Layout for the [AD9208](#)

18547-128

OUTLINE DIMENSIONS



COMPLIANT TO JEDEC STANDARDS MO-275-GGAB-1.

Figure 134. 196-Ball Ball Grid Array, Thermally Enhanced [BGA\_ED]  
 12 mm × 12 mm (BP-196-4)  
 Dimensions shown in millimeters

ORDERING GUIDE

| Model <sup>1</sup> | Temperature Range | Package Description                                   | Package Option |
|--------------------|-------------------|---|----------------|
| AD9208BBPZ-3000    | -40°C to +85°C    | 196-Ball Ball Grid Array, Thermally Enhanced [BGA_ED] | BP-196-4       |
| AD9208BBPZRL-3000  | -40°C to +85°C    | 196-Ball Ball Grid Array, Thermally Enhanced [BGA_ED] | BP-196-4       |
| AD9208-3000EBZ     |                   | Evaluation Board                                      |                |

<sup>1</sup> Z = RoHS Compliant Part.





## Стандарт Электрон Связь

Мы молодая и активно развивающаяся компания в области поставок электронных компонентов. Мы поставляем электронные компоненты отечественного и импортного производства напрямую от производителей и с крупнейших складов мира.

Благодаря сотрудничеству с мировыми поставщиками мы осуществляем комплексные и плановые поставки широчайшего спектра электронных компонентов.

Собственная эффективная логистика и склад в обеспечивает надежную поставку продукции в точно указанные сроки по всей России.

Мы осуществляем техническую поддержку нашим клиентам и предпродажную проверку качества продукции. На все поставляемые продукты мы предоставляем гарантию .

Осуществляем поставки продукции под контролем ВП МО РФ на предприятия военно-промышленного комплекса России , а также работаем в рамках 275 ФЗ с открытием отдельных счетов в уполномоченном банке. Система менеджмента качества компании соответствует требованиям ГОСТ ISO 9001.

Минимальные сроки поставки, гибкие цены, неограниченный ассортимент и индивидуальный подход к клиентам являются основой для выстраивания долгосрочного и эффективного сотрудничества с предприятиями радиоэлектронной промышленности, предприятиями ВПК и научно-исследовательскими институтами России.

С нами вы становитесь еще успешнее!

### Наши контакты:

**Телефон:** +7 812 627 14 35

**Электронная почта:** [sales@st-electron.ru](mailto:sales@st-electron.ru)

**Адрес:** 198099, Санкт-Петербург,  
Промышленная ул, дом № 19, литера Н,  
помещение 100-Н Офис 331