

## SMALL SIGNAL PNP TRANSISTORS

### DESCRIPTION

The 2N2905A and 2N2907A are silicon Planar Epitaxial PNP transistors in Jedec TO-39 (for 2N2905A) and in Jedec TO-18 (for 2N2907A) metal case. They are designed for high speed saturated switching and general purpose applications.

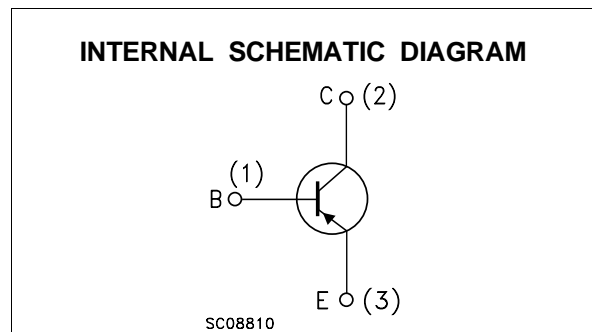
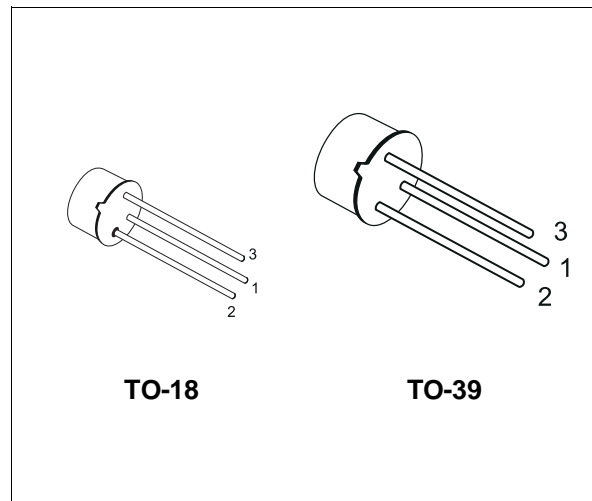

### ABSOLUTE MAXIMUM RATINGS

Symbol	Parameter	Value	Unit
$V_{CBO}$	Collector-Base Voltage ( $I_E = 0$ )	-60	V
$V_{CEO}$	Collector-Emitter Voltage ( $I_B = 0$ )	-60	V
$V_{EBO}$	Emitter-Base Voltage ( $I_C = 0$ )	-5	V
$I_C$	Collector Current	-0.6	A
$I_{CM}$	Collector Peak Current ( $t_p < 5$ ms)	-0.8	A
$P_{tot}$	Total Dissipation at $T_{amb} \leq 25$ °C for <b>2N2905A</b> for <b>2N2907A</b> at $T_C \leq 25$ °C for <b>2N2905A</b> for <b>2N2907A</b>	0.6	W
		0.4	W
		3	W
		1.8	W
$T_{stg}$	Storage Temperature	-65 to 175	°C
$T_j$	Max. Operating Junction Temperature	175	°C

**THERMAL DATA**

			TO-39	TO-18	
R <sub>thj-case</sub>	Thermal Resistance Junction-Case	Max	50	83.3	°C/W
R <sub>thj-amb</sub>	Thermal Resistance Junction-Ambient	Max	250	375	°C/W

**ELECTRICAL CHARACTERISTICS** (T<sub>case</sub> = 25 °C unless otherwise specified)

Symbol	Parameter	Test Conditions	Min.	Typ.	Max.	Unit
I <sub>CBO</sub>	Collector Cut-off Current (I <sub>E</sub> = 0)	V <sub>CB</sub> = -50 V V <sub>CB</sub> = -50 V T <sub>J</sub> = 150 °C			-10 -10	nA μA
I <sub>CEX</sub>	Collector Cut-off Current (V <sub>BE</sub> = 0.5V)	V <sub>CE</sub> = -30 V			-50	nA
I <sub>BEX</sub>	Base Cut-off Current (V <sub>BE</sub> = 0.5V)	V <sub>CE</sub> = -30 V			-50	nA
V <sub>(BR)CBO</sub>	Collector-Base Breakdown Voltage (I <sub>E</sub> = 0)	I <sub>C</sub> = -10 μA	-60			V
V <sub>(BR)CEO*</sub>	Collector-Emitter Breakdown Voltage (I <sub>B</sub> = 0)	I <sub>C</sub> = -10 mA	-60			V
V <sub>(BR)EBO</sub>	Emitter-Base Breakdown Voltage (I <sub>C</sub> = 0)	I <sub>E</sub> = -10 μA	-5			V
V <sub>CE(sat)*</sub>	Collector-Emitter Saturation Voltage	I <sub>C</sub> = -150 mA I <sub>B</sub> = -15 mA I <sub>C</sub> = -500 mA I <sub>B</sub> = -50 mA			-0.4 -1.6	V V
V <sub>BE(sat)*</sub>	Base-Emitter Saturation Voltage	I <sub>C</sub> = -150 mA I <sub>B</sub> = -15 mA I <sub>C</sub> = -500 mA I <sub>B</sub> = -50 mA			-1.3 -2.6	V V
h <sub>FE*</sub>	DC Current Gain	I <sub>C</sub> = -0.1 mA V <sub>CE</sub> = -10 V I <sub>C</sub> = -1 mA V <sub>CE</sub> = -10 V I <sub>C</sub> = -10 mA V <sub>CE</sub> = -10 V I <sub>C</sub> = -150 mA V <sub>CE</sub> = -10 V I <sub>C</sub> = -500 mA V <sub>CE</sub> = -10 V	75 100 100 100 50		300	
f <sub>T</sub>	Transition Frequency	V <sub>CE</sub> = -20 V f = 100 MHz I <sub>C</sub> = -50 mA	200			MHz
C <sub>EBO</sub>	Emitter-Base Capacitance	I <sub>C</sub> = 0 V <sub>EB</sub> = -2 V f = 1MHz			30	pF
C <sub>CBO</sub>	Collector-Base Capacitance	I <sub>E</sub> = 0 V <sub>CB</sub> = -10 V f = 1MHz			8	pF
t <sub>d**</sub>	Delay Time	V <sub>CC</sub> = -30 V I <sub>C</sub> = -150 mA I <sub>B1</sub> = -15 mA			10	ns
t <sub>r**</sub>	Rise Time	V <sub>CC</sub> = -30 V I <sub>C</sub> = -150 mA I <sub>B1</sub> = -15 mA			40	ns
t <sub>s**</sub>	Storage Time	V <sub>CC</sub> = -6 V I <sub>C</sub> = -150 mA I <sub>B1</sub> = -I <sub>B2</sub> = -15 mA			80	ns
t <sub>f**</sub>	Fall Time	V <sub>CC</sub> = -6 V I <sub>C</sub> = -150 mA I <sub>B1</sub> = -I <sub>B2</sub> = -15 mA			30	ns
t <sub>on**</sub>	Turn-on Time	V <sub>CC</sub> = -30 V I <sub>C</sub> = -150 mA I <sub>B1</sub> = -15 mA			45	ns
t <sub>off**</sub>	Turn-off Time	V <sub>CC</sub> = -6 V I <sub>C</sub> = -150 mA I <sub>B1</sub> = -I <sub>B2</sub> = -15 mA			100	ns

\* Pulsed: Pulse duration = 300 μs, duty cycle ≤ 1 %

\*\* See test circuit

Normalized DC Current Gain.

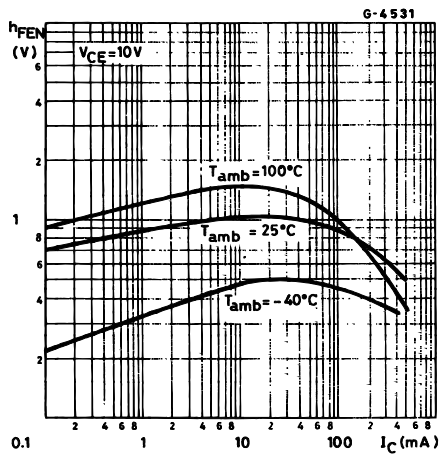

Collector Emitter Saturation Voltage.

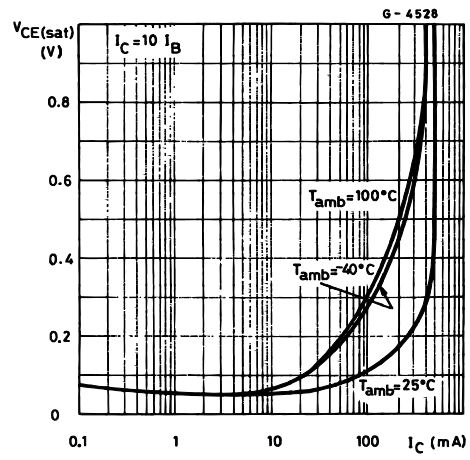

Collector Base and Emitter-base capacitances.

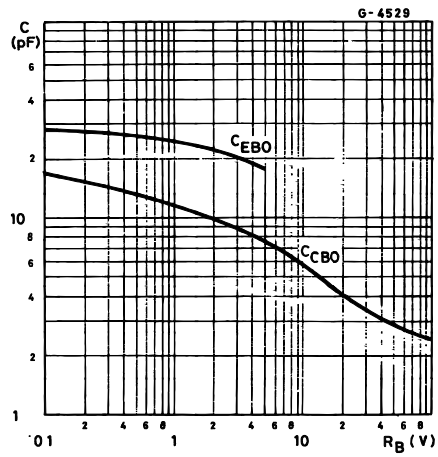

Switching Characteristics.

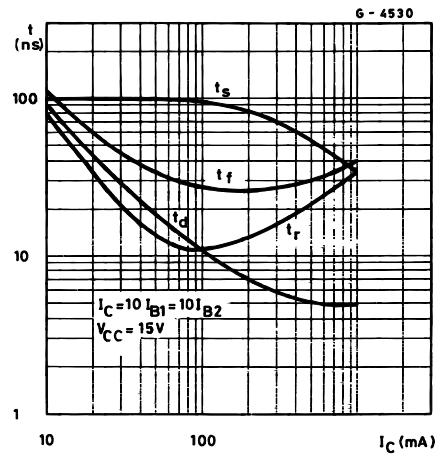

2N2905A/2N2907A

Test Circuit for  $t_{on}$ ,  $t_r$ ,  $t_d$ .

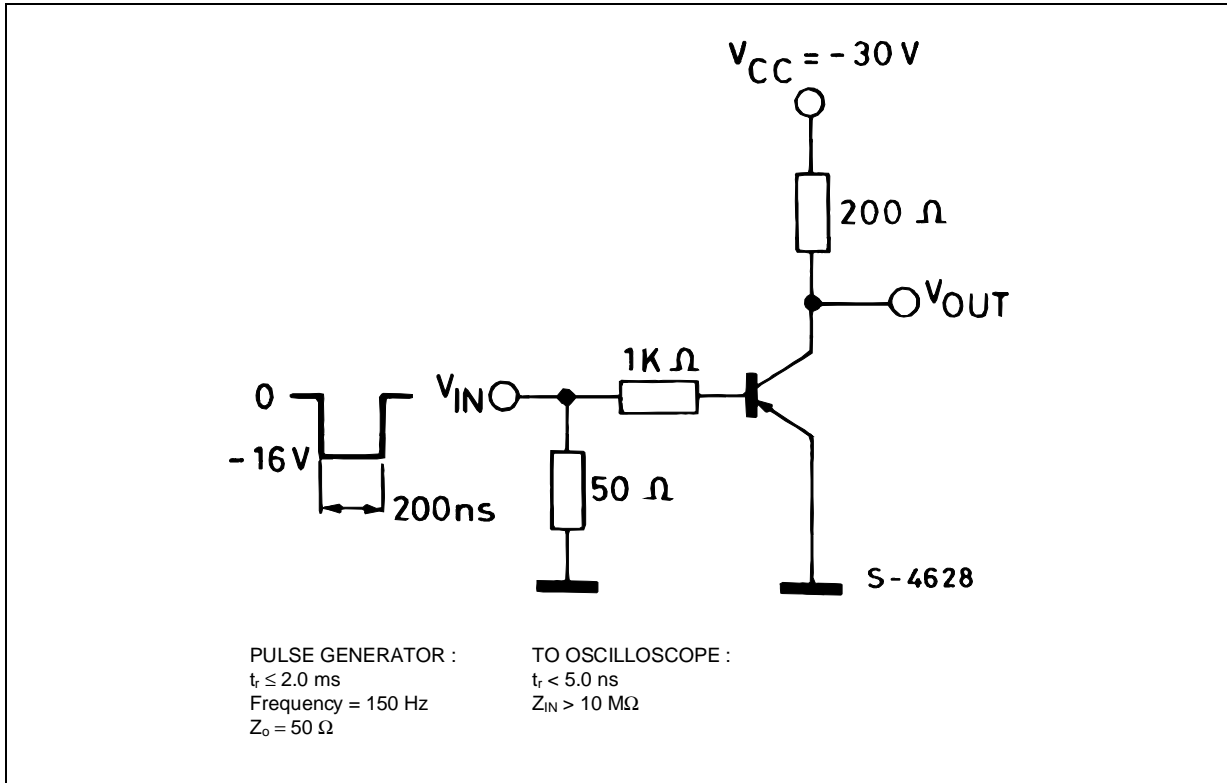

Test Circuit for  $t_{off}$ ,  $t_o$ ,  $t_f$ .

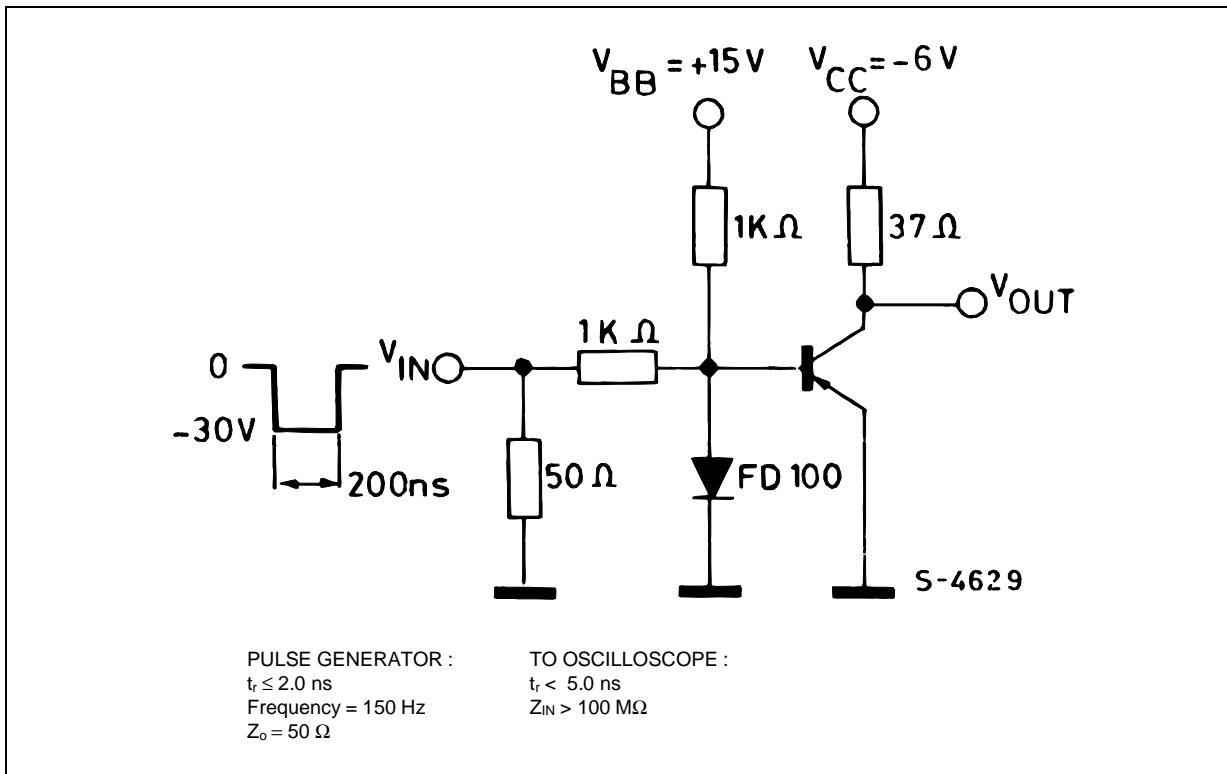

## TO-18 MECHANICAL DATA

DIM.	mm			inch		
	MIN.	TYP.	MAX.	MIN.	TYP.	MAX.
A		12.7			0.500	
B			0.49			0.019
D			5.3			0.208
E			4.9			0.193
F			5.8			0.228
G	2.54			0.100		
H			1.2			0.047
I			1.16			0.045
L	45°			45°		

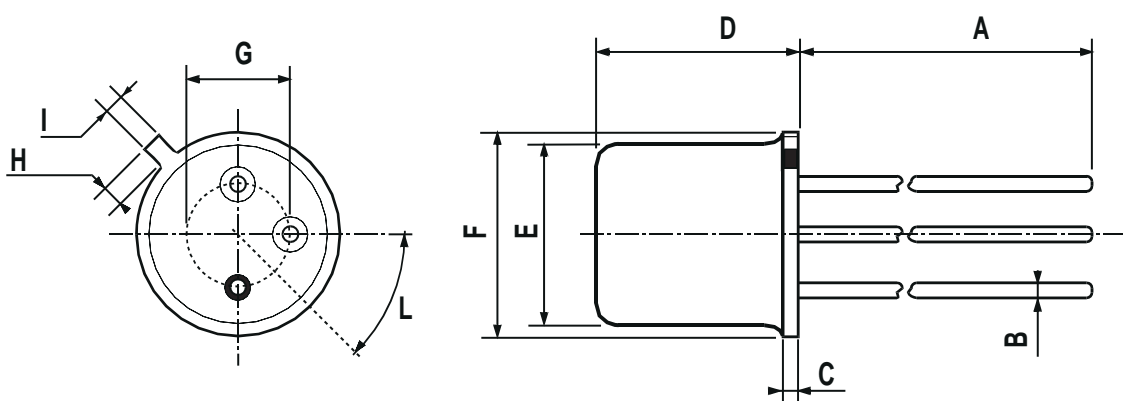

0016043

**TO-39 MECHANICAL DATA**

DIM.	mm			inch		
	MIN.	TYP.	MAX.	MIN.	TYP.	MAX.
A	12.7			0.500		
B			0.49			0.019
D			6.6			0.260
E			8.5			0.334
F			9.4			0.370
G	5.08			0.200		
H			1.2			0.047
I			0.9			0.035
L	45° (typ.)					

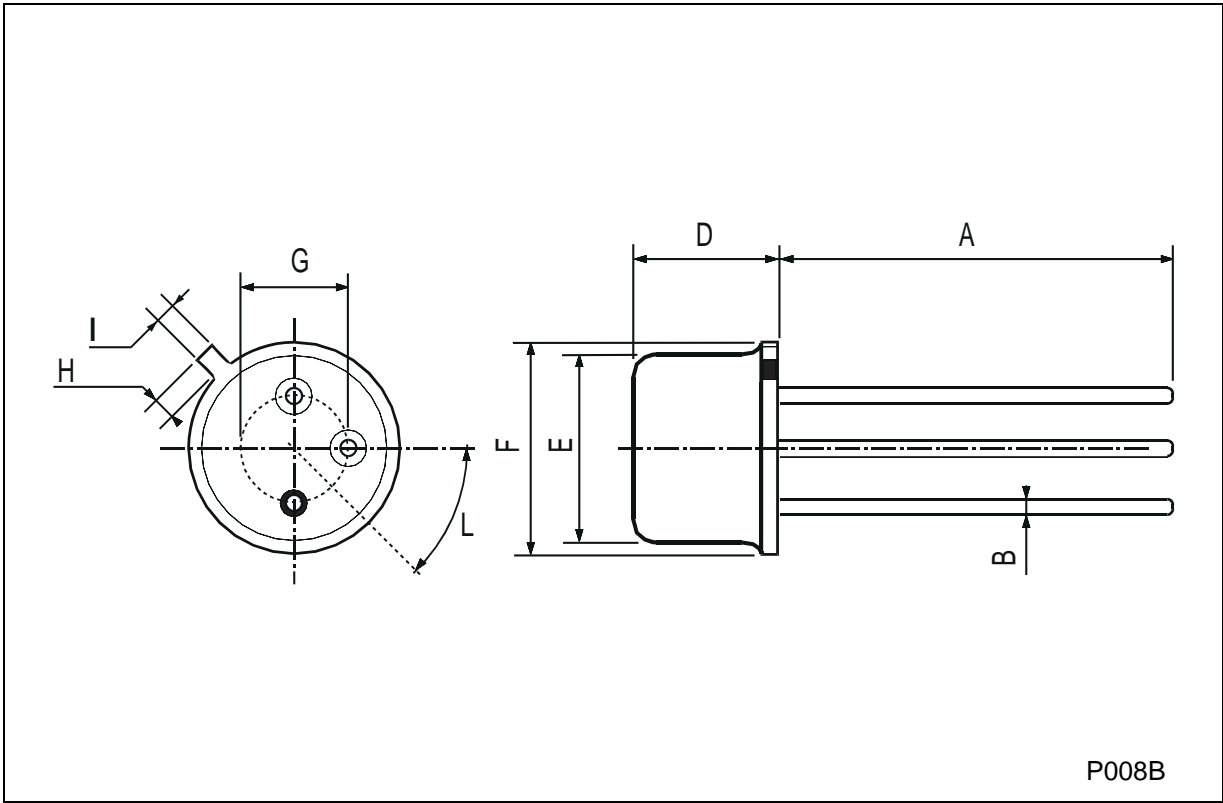

P008B

Information furnished is believed to be accurate and reliable. However, STMicroelectronics assumes no responsibility for the consequences of use of such information nor for any infringement of patents or other rights of third parties which may result from its use. No license is granted by implication or otherwise under any patent or patent rights of STMicroelectronics. Specification mentioned in this publication are subject to change without notice. This publication supersedes and replaces all information previously supplied. STMicroelectronics products are not authorized for use as critical components in life support devices or systems without express written approval of STMicroelectronics.

The ST logo is a trademark of STMicroelectronics

© 2003 STMicroelectronics – Printed in Italy – All Rights Reserved

STMicroelectronics GROUP OF COMPANIES

Australia - Brazil - Canada - China - Finland - France - Germany - Hong Kong - India - Israel - Italy - Japan - Malaysia - Malta - Morocco - Singapore - Spain - Sweden - Switzerland - United Kingdom - United States.

<http://www.st.com>



## Стандарт Электрон Связь

Мы молодая и активно развивающаяся компания в области поставок электронных компонентов. Мы поставляем электронные компоненты отечественного и импортного производства напрямую от производителей и с крупнейших складов мира.

Благодаря сотрудничеству с мировыми поставщиками мы осуществляем комплексные и плановые поставки широчайшего спектра электронных компонентов.

Собственная эффективная логистика и склад в обеспечивает надежную поставку продукции в точно указанные сроки по всей России.

Мы осуществляем техническую поддержку нашим клиентам и предпродажную проверку качества продукции. На все поставляемые продукты мы предоставляем гарантию .

Осуществляем поставки продукции под контролем ВП МО РФ на предприятия военно-промышленного комплекса России , а также работаем в рамках 275 ФЗ с открытием отдельных счетов в уполномоченном банке. Система менеджмента качества компании соответствует требованиям ГОСТ ISO 9001.

Минимальные сроки поставки, гибкие цены, неограниченный ассортимент и индивидуальный подход к клиентам являются основой для выстраивания долгосрочного и эффективного сотрудничества с предприятиями радиоэлектронной промышленности, предприятиями ВПК и научно-исследовательскими институтами России.

С нами вы становитесь еще успешнее!

### Наши контакты:

**Телефон:** +7 812 627 14 35

**Электронная почта:** [sales@st-electron.ru](mailto:sales@st-electron.ru)

**Адрес:** 198099, Санкт-Петербург,  
Промышленная ул, дом № 19, литера Н,  
помещение 100-Н Офис 331