

# Multi-channel Switching ICs for Engine Management Applications

## TLE9104SH, TLE8110ED & TLE8718SA Evaluation Boards and GUI User Manual

### About this document

This document details the functionality and the required steps for operating the evaluation kits for Infineon’s TLE9104SH, TLE8110ED and TLE8718SA multi-channel switching ICs. Included are instructions for setting up the evaluation boards and for using the accompanying graphical user interface (GUI). The TLE9104SH, TLE8110ED and TLE8718SA are power switching ICs which are best suited for automotive engine management applications.

### Table of contents

<b>About this document.....</b>	<b>1</b>
<b>Table of contents.....</b>	<b>1</b>
<b>1 Hardware Configuration .....</b>	<b>3</b>
1.1 TLE9104SH - Evaluation Board .....	3
1.1.1 Power and Load Connections.....	4
1.1.2 Signal Connections .....	6
1.1.3 Indicator LEDs .....	6
1.1.4 Schematics .....	7
1.2 TLE8110ED – Evaluation Board.....	8
1.2.1 Power and Load Connections.....	8
1.2.2 Signal Connections .....	10
1.2.3 Indicator LEDs .....	11
1.2.4 Schematics .....	12
1.3 TLE8718SA – Evaluation Board .....	13
1.3.1 Power and Load Connections.....	13
1.3.2 Signal Connections .....	15
1.3.3 Indicator LEDs .....	16
1.3.4 Schematics .....	17
1.4 Connection Board .....	18
1.4.1 Connections to TLE9104SH evaluation board .....	19
1.4.2 Connections to TLE8110ED evaluation board .....	22
1.4.3 Connections to TLE8718SA evaluation board.....	23
1.4.4 Connections to TC277 Triboard.....	24
1.4.5 Supply and Battery Connection .....	26
<b>2 Software .....</b>	<b>27</b>
2.1 Graphical User Interface (GUI) .....	27
2.1.1 Main Window .....	27
2.1.2 Evaluation Board Tabs.....	29
2.1.2.1 Tetris_A (TLE9104SH).....	29
2.1.2.2 Flex10_B (TLE8100ED) .....	31
2.1.2.3 Flex18 (TLE8718SA) .....	32

<b>3</b>	<b>Appendix.....</b>	<b>39</b>
3.1	Common Connection PCB Schematic .....	39
3.2	Command List .....	39
3.2.1	General Information.....	39
3.2.2	Initialization Commands.....	40
3.2.3	List of Commands .....	40
	<b>Revision history.....</b>	<b>45</b>

# 1 Hardware Configuration

The evaluation boards for the three engine management ICs are equipped with an external power supply connection, a 12V battery connection, a load connection, several signal test points as well as jumpers for testing purposes. These evaluation boards can be operated in one of two ways. The three evaluation boards may be mounted on a common connection board which interfaces with an Infineon AURIX TC277 Triboard (as illustrated in Figure 1-1), or alternatively each of the three boards is plugged onto an Infineon microcontroller.

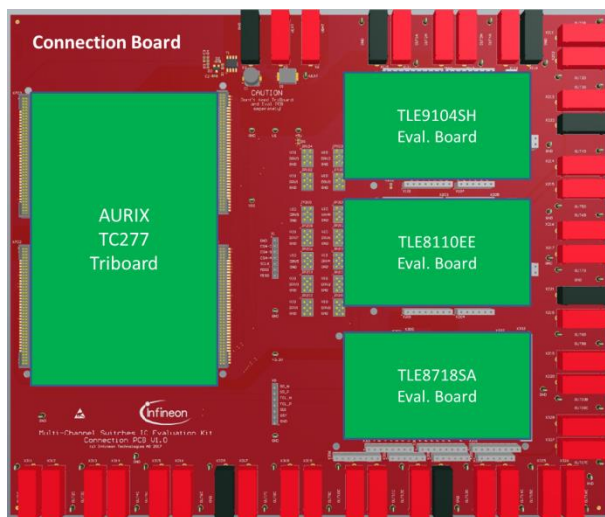

**Figure 1-1 All evaluation boards and AURIX TC277 Triboard can be plugged onto a common connection PCB.**

Table 1-1 presents the Infineon microcontrollers which are compatible with the three evaluation boards of the TLE9104SH, TLE8110ED and TLE8718SA multi-channel switching ICs.

**Table 1-1 Microcontroller evaluation boards which are compatible with the engine management evaluation kits**

IC evaluation kit	Microcontroller evaluation boards
TLE9104SH	XMC1100/XMC4700
TLE8110ED	XMC1100/XMC4700
TLE8718SA	Shieldbody TC275 Board

## 1.1 TLE9104SH - Evaluation Board

Figure 1-2 provides an overview of the component blocks of the evaluation kit of the TLE9104SH. Here, the supply connections, including an external supply connector (X1), battery connector (X3) and two types of load connectors (X2, X106-109) are provided. A battery reverse protection circuit is available when the battery is connected to X1. Supply and digital signals are accessible with connector X101, and X103/X105. Note that if a common connection board like that of Figure 1-1 is used to test multiple ICs, it is recommended to connect the 12V battery to the connection board and power all the evaluation boards via the Vext connector on the connection board.

# Multi-channel Low-Side Switching ICs

## Evaluation Kits for TLE9104SH, TLE8110ED and TLE8718SA

### Hardware Configuration

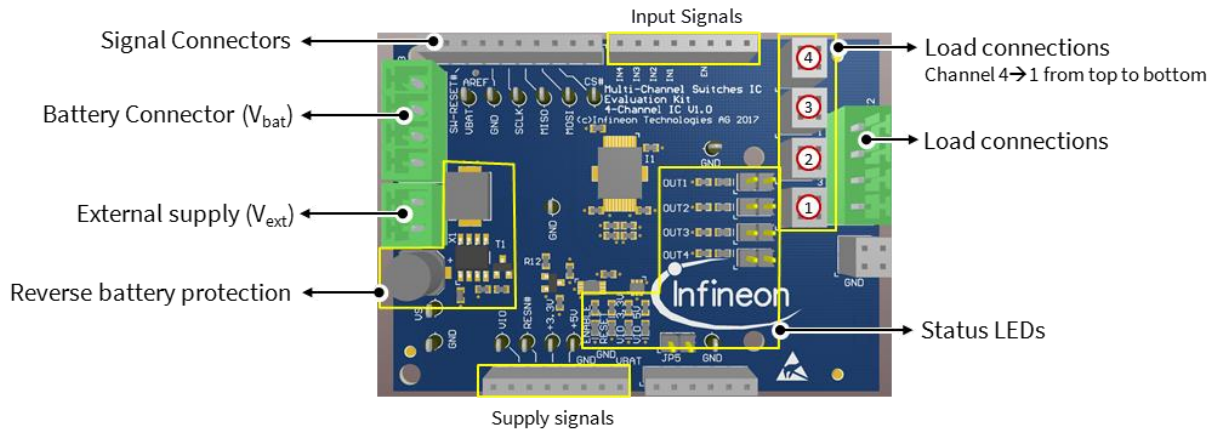

**Figure 1-2 Functional blocks on the evaluation board of TLE9104SH.**

### 1.1.1 Power and Load Connections

#### Power Connections

When connected to a microcontroller board, the TLE9104SH evaluation board can be powered by one of two ways:

1. If the user wants to utilize the 12V battery as the sole power source (for the microcontroller board, IC evaluation board and loads), the battery can be plugged to the connector X1 (V<sub>ext</sub>), with the jumper JP5 connected.
2. If it is preferred to use the battery only for loads, the battery should be connected to the connector X3 with JP5 open. In this case, the external supply can be connected with microcontroller board or connector X1 on the IC evaluation board.

The battery reverse protection circuit is shown in Figure 1-3.

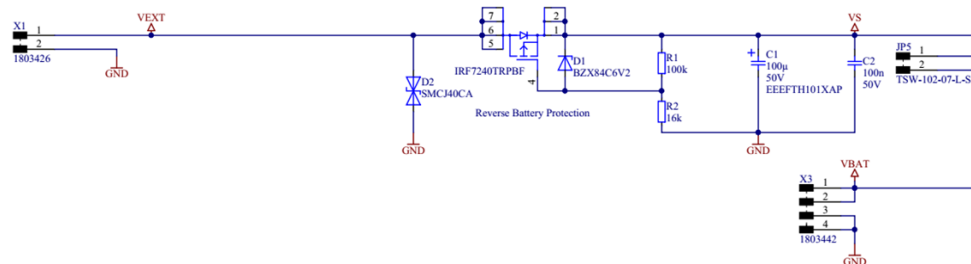

**Figure 1-3 Supply connection and battery reverse protection on the evaluation board**

#### Load Connections

The four loads can be connected with the connector X2 or connectors X106-X109. Different from X2, the battery connections are available with X106-X109. Figure 1-4 depicts the schematics of load connections and the LED circuits indicating the load status.

Remove jumpers (JP1-JP4) in series with the status-indicating LEDs on the output pins if a reverse voltage of more than 5V is expected.

# Multi-channel Low-Side Switching ICs

## Evaluation Kits for TLE9104SH, TLE8110ED and TLE8718SA

### Hardware Configuration

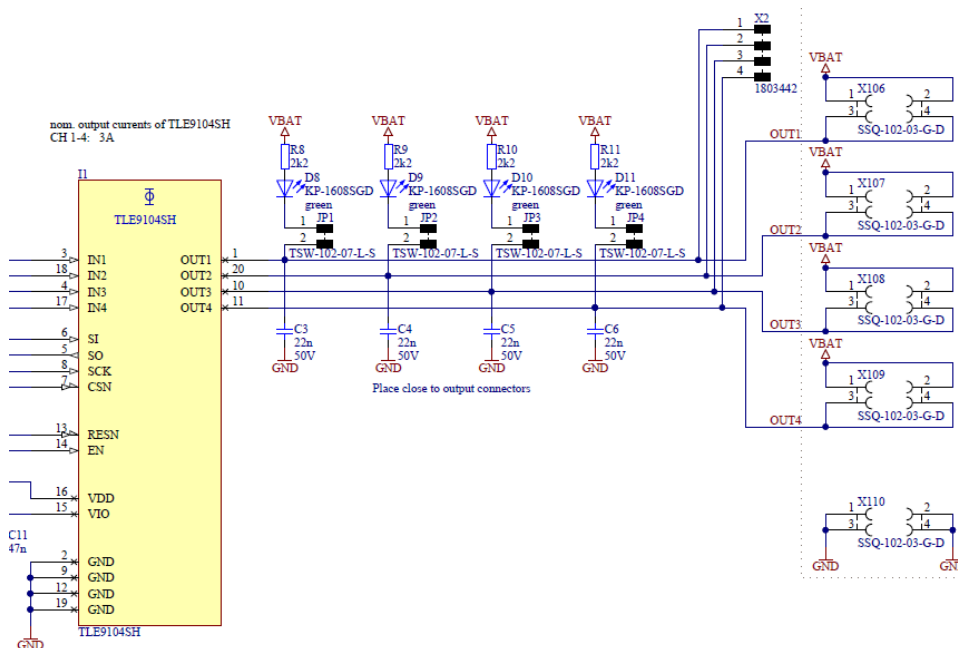

**Figure 1-4 Load Connection and indication LED circuit**

Table 1-2 describes the name and function of each X101 pin on the IC evaluation kit and the XMC1100 board.

**Table 1-2 Signal description on connector X101**

Pin Number	Signal name on Evaluation PCB	Signal name on XMC1100 Board	Description
1	-	-	-
2	VIO	IOREF	Signal Supply Voltage
3	Reset#	RESET	Reset (active low)
4	+3.3V	3V3	3.3 V supply from uC board
5	+5V	5V	5 V supply from uC board
6	GND	GND	Ground
7	GND	GND	Ground
8	Vs	VIN	DC Supply voltage after reverse battery protection circuit (7-12V)

**Hardware Configuration**

**1.1.2 Signal Connections**

Table 1-3 and Table 1-4 describe the names and functions of the X103 and X105 connector pins on the IC evaluation PCB and the XMC1100 microcontroller board.

**Table 1-3 Signal description on connector X103**

Pin Number	Signal name on Evaluation PCB	Signal name on XMC1100 Board	Description
1	-	P0.12	-
2	-	P0.8	-
3	CS#	P0.9	Serial Chip Select (active low)
4	MOSI	P1.1	Serial data input
5	MISO	P1.0	Serial data output
6	SCLK	P0.7	Serial Clock
7	GND	GND	Ground
8	AREF	P2.3	Analog reference voltage
9	SW-RESET#	P2.1	Reset by software
10	-	P2.0	-

**Table 1-4 Signal description on connector X105**

Pin Number	Signal name on Evaluation PCB	Signal name on XMC1100 Board	Description
1	-	P1.2	-
2	-	P1.3	-
3	EN	P1.4	Output Enable
4	-	P0.0	-
5	IN1	P0.1	Input 1 (3A continuous)
6	IN2	P0.2	Input 2 (3A continuous)
7	IN3	P0.3	Input 3 (3A continuous)
8	IN4	P0.4	Input 4 (3A continuous)

**1.1.3 Indicator LEDs**

The indicator LEDs which are mounted on the TLE9104SH's evaluation board can be seen in Figure 1-5.

Either D3 or D4 is on, depending on whether VIO is set to 3.3V or 5V respectively.

D6 is on when the chip is in reset mode.

D7 indicates whether the output is enabled by "EN".

D8-D11 indicate whether the corresponding load is connected to ground or not.

# Multi-channel Low-Side Switching ICs

## Evaluation Kits for TLE9104SH, TLE8110ED and TLE8718SA



### Hardware Configuration

#### 1.1.4 Schematics

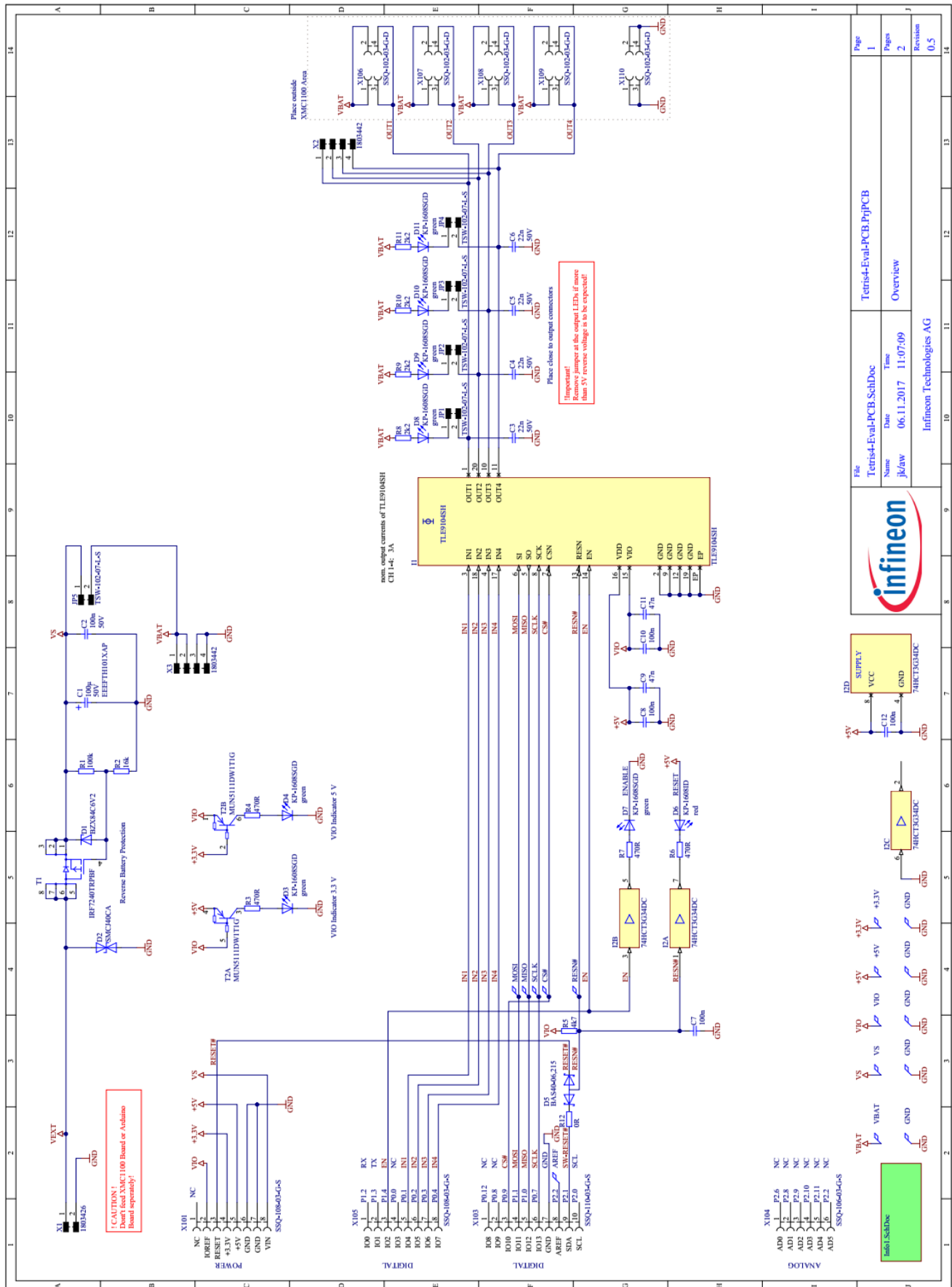

Figure 1-5 Schematic of TLE9104SH evaluation board

# Multi-channel Low-Side Switching ICs

## Evaluation Kits for TLE9104SH, TLE8110ED and TLE8718SA

### Hardware Configuration

#### 1.2 TLE8110ED – Evaluation Board

Figure 1-6 gives an overview of the component blocks on the Evaluation PCB of the TLE8110ED. Here, the supply connections, including an external supply connector (X1), battery connector (X5) and two types of load connectors are provided. Similar to the case of the TLE9104SH board, a battery reverse protection circuit is also available when the battery is connected to X1. Supply and digital signals are accessible via the connector X201, and X203-X105. Note that if a common connection PCB carrier (Figure 1-1) is used to test different ICs at once, it is recommended to connect the 12V battery to the connection PCB and power the entire evaluation board sets via the Vext connector on the connection PCB.

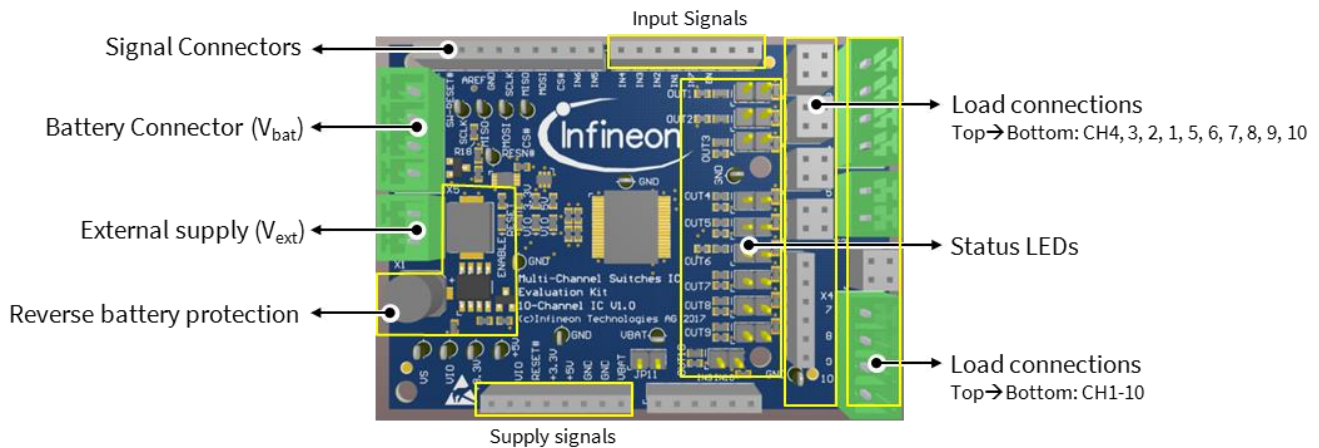

Figure 1-6 Functional blocks on the evaluation board of TLE8110ED.

#### 1.2.1 Power and Load Connections

##### Power Connections

When connected to a microcontroller board, the TLE8110ED evaluation board can be powered in one of two ways, similar to the power up of the TLE9104SH board. Please refer to section 1.1.1.

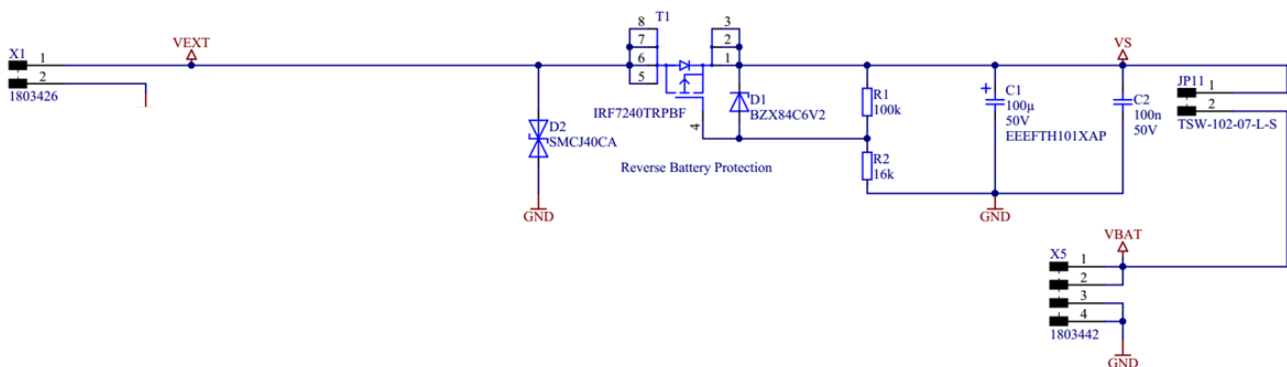

Figure 1-7 Supply connection and battery reverse protection on the evaluation board

##### Load Connections

The ten loads can be connected with the connectors X2-X4 or connectors X206-X210. Figure 1-8 shows the schematics of load connections and LED circuits indicating the load status.



Remove jumpers (JP1-JP10) in series with the status-indicating LEDs on the output pins if a reverse voltage of more than 5V is expected.

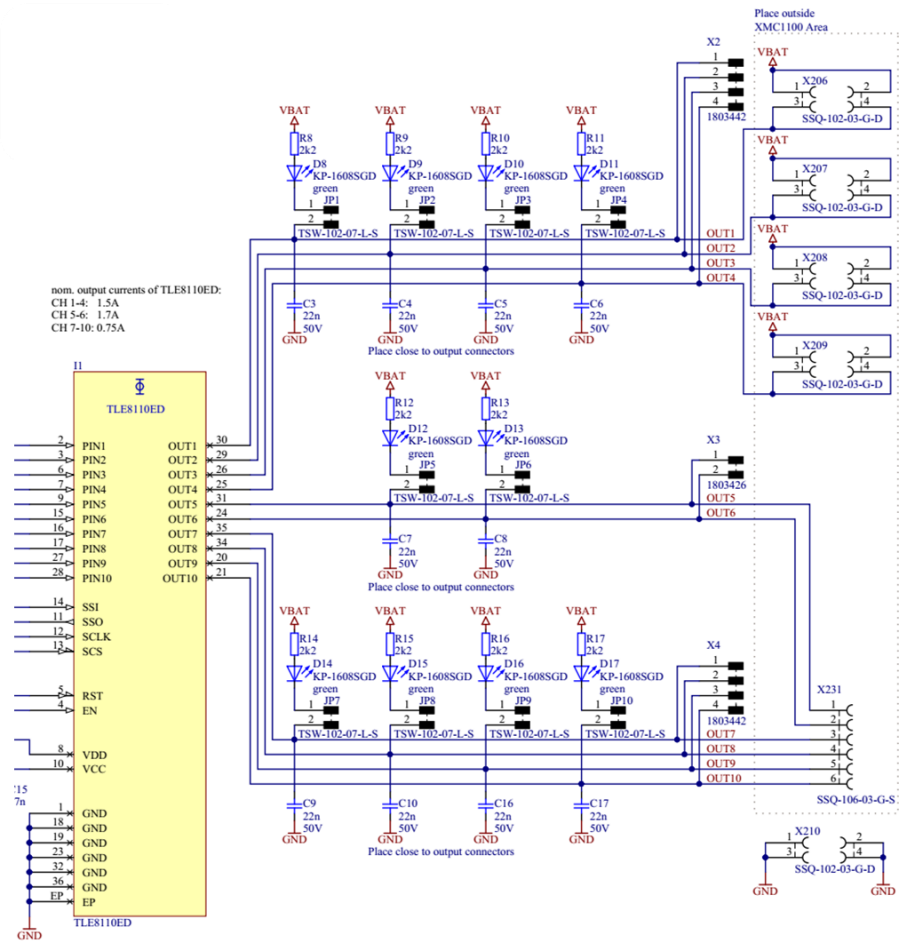

**Figure 1-8 Load connection and indication LED circuit**

Table 1-5 describes the name and function of each X101 pin on IC evaluation PCB and XMC1100 board.

**Table 1-5 Signal description on connector X201**

Pin Number	Signal name on Evaluation PCB	Signal name on XMC1100 Board	Description
1	-	-	-
2	VIO	IOREF	Signal Supply Voltage
3	Reset#	RESET	Reset (active low)
4	+3.3V	3V3	3.3 V supply from uC board
5	+5V	5V	5 V supply from uC board
6	GND	GND	Ground
7	GND	GND	Ground

### Hardware Configuration

8	Vs	VIN	DC Supply voltage after reverse battery protection circuit (7-12V)
---	----	-----	--

## 1.2.2 Signal Connections

Table 1-6, Table 1-7 and Table 1-8 describe the names and functions of the X203-X205 connector pins on the IC evaluation kit and the XMC1100 microcontroller board.

**Table 1-6 Signal description on connector X203**

Pin Number	Signal name on Evaluation PCB	Signal name on XMC1100 Board	Description
1	IN5	P0.12	Input 5 (1.7A nominal)
2	IN6	P0.8	Input 6 (1.7A nominal)
3	CS#	P0.9	Serial Chip Select (active low)
4	MOSI	P1.1	Serial data input
5	MISO	P1.0	Serial data output
6	SCLK	P0.7	Serial Clock
7	GND	GND	Ground
8	AREF	P2.3	Analog reference voltage
9	SW-RESET#	P2.1	Reset by software
10	IN8	P2.0	Input 8 (0.75A continuous)

**Table 1-7 Signal description on connector X204**

Pin Number	Signal name on Evaluation PCB	Signal name on XMC1100 Board	Description
1	-	P2.6	-
2	-	P2.8	-
3	-	P2.9	-
4	IN9	P2.10	Input 9 (0.75A continuous)
5	IN10	P2.11	Input 10 (0.75A continuous)
6	-	P2.2	-

**Table 1-8 Signal description on connector X205**

Pin Number	Signal name on Evaluation PCB	Signal name on XMC1100 Board	Description
1	-	P1.2	-
2	-	P1.3	-
3	EN	P1.4	Output Enable
4	-	P0.0	-
5	IN1	P0.1	Input 1 (1.5A continuous)
6	IN2	P0.2	Input 2 (1.5A continuous)
7	IN3	P0.3	Input 3 (1.5A continuous)
8	IN4	P0.4	Input 4 (1.5A continuous)

### 1.2.3 Indicator LEDs

The indicator LEDs which are mounted on the TLE8110ED’s evaluation board can be seen in the schematic of Figure 1-9.

Either D3 or D4 is on, depending on whether VIO is set to 3.3V or 5V respectively.

D6 is on when the chip is in reset mode.

D7 indicates whether the output is enabled by “EN”.

D8-D17 indicate whether the corresponding load is connected to ground or not.

Hardware Configuration

1.2.4 Schematics

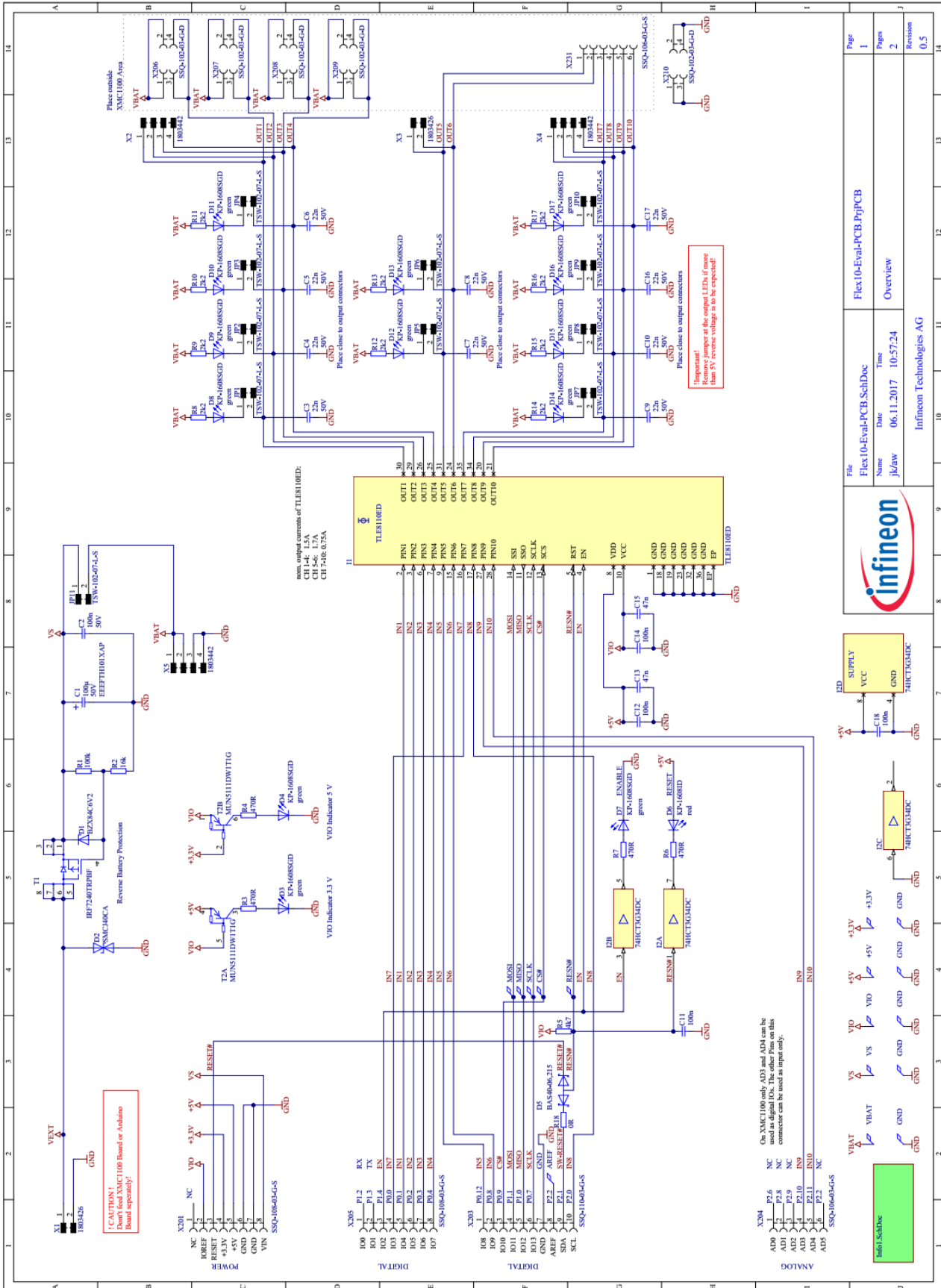

Figure 1-9 Schematic of TLE8110ED evaluation board

Page	1
Pages	2
Revision	0.5
File	Flex10-Eval-PCB.PjPCB
Name	Flex10-Eval-PCB.SchDoc
Date	06.11.2017
Time	10:57:24
Overview	
Author	JK/aw
Infineon Technologies AG	

# Multi-channel Low-Side Switching ICs

## Evaluation Kits for TLE9104SH, TLE8110ED and TLE8718SA

### Hardware Configuration

### 1.3 TLE8718SA – Evaluation Board

Figure 1-10 gives an overview of the component blocks on the evaluation board of the TLE8718SA. The supply connections, including an external supply connector (X1), battery connector (X7) and two types of load connectors are provided. As with the TLE9104SH board, a battery reverse protection circuit is also available when the battery is connected to X1. Supply and digital signals are accessible with connector X301-X305. Note that if a common connection board is used to test multiple ICs, it is recommended to connect the 12V battery to the connection PCB and power the entire evaluation board sets via the Vext connector on the connection PCB.

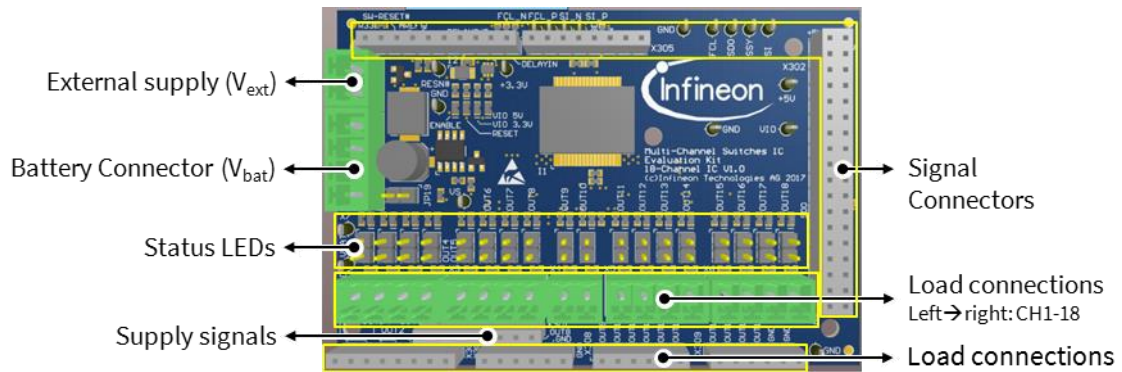
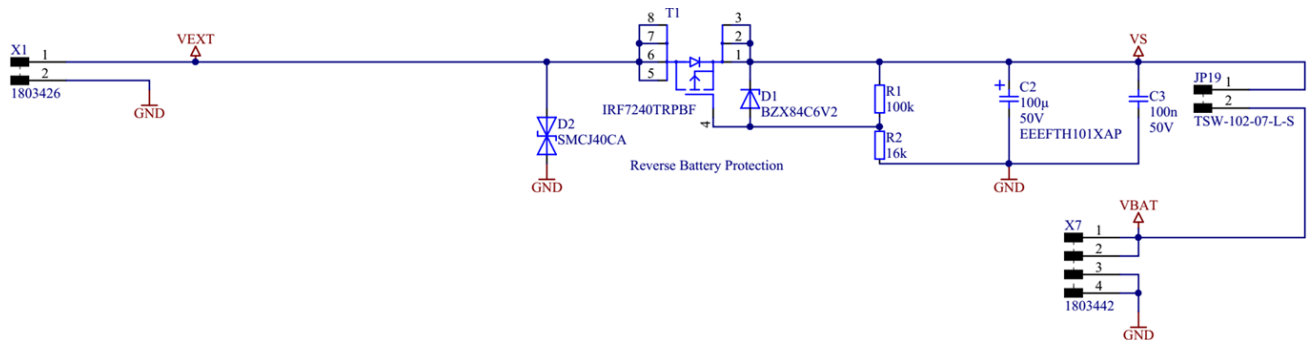

**Figure 1-10 Functional blocks on the evaluation board of TLE8718SA**

### 1.3.1 Power and Load Connections

#### Power Connections

When connected to a microcontroller board, the TLE8110ED evaluation board can be powered by two ways similar to TLE9104SH board, as explained in section 1.1.1.



**Figure 1-11 Supply connection and battery reverse protection on the evaluation board**

#### Load Connections

The 18 loads can be connected with connector X2-X6 or connectors X306-X309. Figure 1-8 shows the schematics of load connections and LED circuits indicating the load status.

Remove jumpers (JP1-JP18) in series with the status-indicating LEDs on the output pins if a reverse voltage of more than 5V is expected.

# Multi-channel Low-Side Switching ICs

## Evaluation Kits for TLE9104SH, TLE8110ED and TLE8718SA

### Hardware Configuration

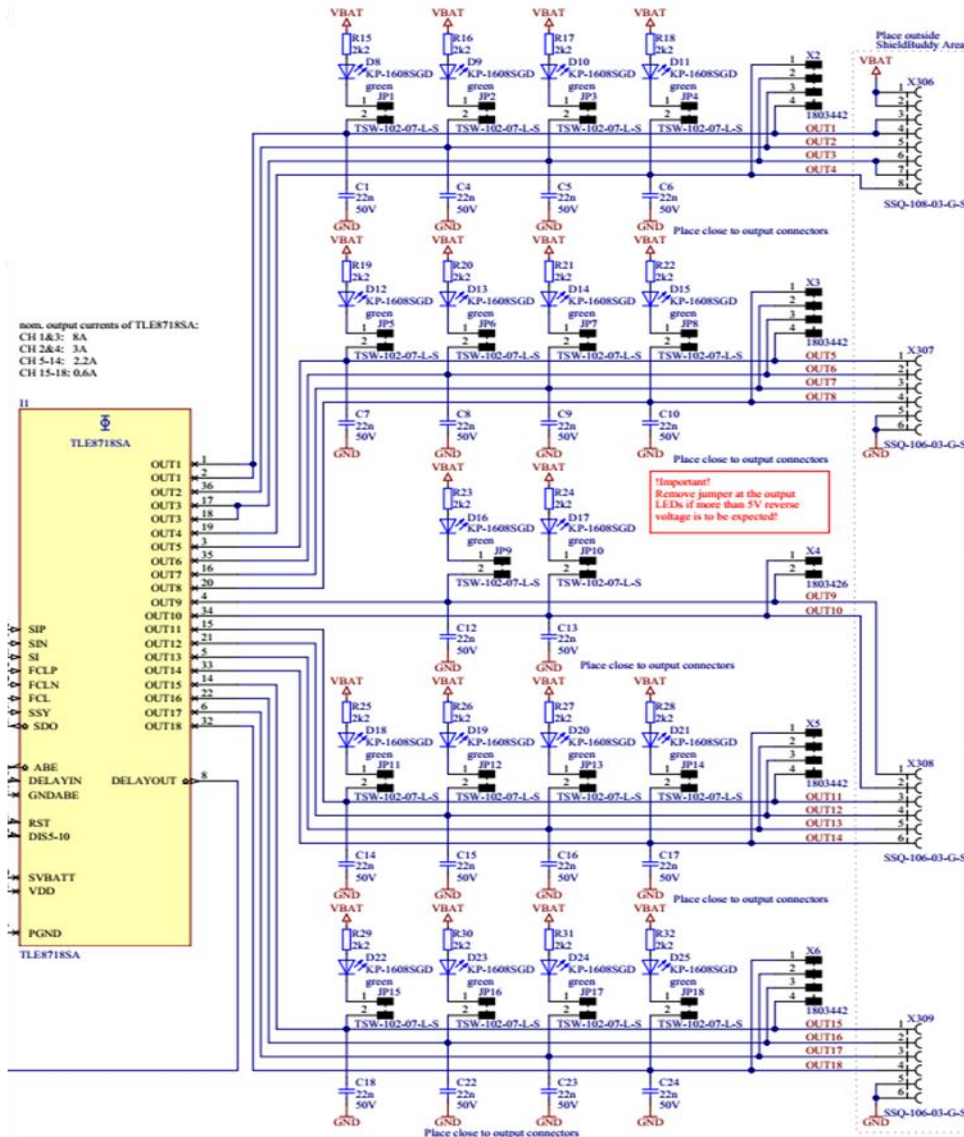

**Figure 1-12 Load Connection and indication LED circuit**

Table 1-9 describes the name and function of each X301 pin on the IC evaluation kit and TC275 Shieldbody board.

**Table 1-9 Signal description on connector X301**

Pin Number	Signal name on Evaluation PCB	Signal name on Shieldbody Board	Description
1	-	-	-
2	VIO	IOREF	Signal Supply Voltage
3	Reset#	RESET	Reset (active low)
4	+3.3V	3V3	3.3 V supply from uC board
5	+5V	5V	5 V supply from uC board
6	GND	GND	Ground
7	GND	GND	Ground

**Hardware Configuration**

8	Vs	VIN	DC Supply voltage after reverse battery protection circuit (7-12V)
---	----	-----	--

**1.3.2 Signal Connections**

Table 1-10 to Table 1-12 describe the names and functions of X302, X303, X305 connector pins on the IC evaluation boards and Shieldbody TC275 board.

**Table 1-10 Signal description on connector X302**

Pin Number	Signal name on Evaluation PCB	Signal name on XMC1100 Board	Description
1, 2	+5V	+5V	5V Supply
3-20, 22	-	-	-
21	SI	P11.9	MSC interface optional downstream data input for single ended interface
23	SSY	P11.11	MSC interface. Chip select and synchronization strobe
24	SDO	P11.10	MSC interface. Upstream data, open drain output
27	FCL	P11.6	MSC interface optional clock input for single ended interface
25, 26, 28-33	-	-	-
35, 36	GND	GND	Ground

**Table 1-11 Signal description on connector X303**

Pin Number	Signal name on Evaluation PCB	Signal name on XMC1100 Board	Description
1	DELAYIN	P02.6	DELAYIN input (internal pull-down, active low): Disable pin for DELAYOUT after the configurable filtering time ( $t_{DELAYIN}$ ) has expired and Reset pin for OUT15 and OUT16.
2	DELAYOUT	P02.7	Open drain output generating active low level if DELAYIN is low level (below $V_{DELAYIN\_L}$ ) and $t_{DELAYIN}$ has expired, input ABE disables stages or VDD monitoring has detected a supply voltage failure.
3, 4, 5, 6	-	-	-
7	GND	GND	Ground
8	AREF	AREF0	Analog reference voltage
9	SW-RESET#	P13.2	Reset input (active low, internal pull-up). Shuts down all stages regardless of their input signals. Clears the fault registers and resets the MSC interface registers (partially).

### Hardware Configuration

10	-	P13.1	-
----	---	-------	---

**Table 1-12 Signal description on connector X305**

Pin Number	Signal name on Evaluation PCB	Signal name on XMC1100 Board	Description
1	-	P15.3	-
2	-	P15.2	-
3	EN	P2.0	Disable pin for OUT5...OUT10 (low level disables OUT5...OUT10 after filtering time ( $t_{DIS5\_10}$ ) has expired).
4	ABE	P2.1	Bidirectional pin (active low). Indicates VDD overvoltage and undervoltage condition by pulling ABE-pin low. If forced to low from externally all stages are turned off.
5	SI_P	P10.4	MSC interface. Downstream data positive for differential interface.
6	SI_N	P2.3	MSC interface. Downstream data negative for differential interface.
7	FCL_P	P2.4	MSC interface. Clock positive for differential interface
8	FCL_N	P2.5	MSC interface. Clock negative for differential interface.

### 1.3.3 Indicator LEDs

The indicator LEDs which are mounted on the TLE8110ED's evaluation board can be seen in the schematic of Figure 1-13.

Either D3 or D4 is on, depending on whether VIO is set to 3.3V or 5V respectively.

D6 is on when the chip is in reset mode.

D7 indicates whether the output is enabled by "EN".

D8-D21 indicate whether the corresponding load is connected to ground or not.



### 1.3.4 Schematics

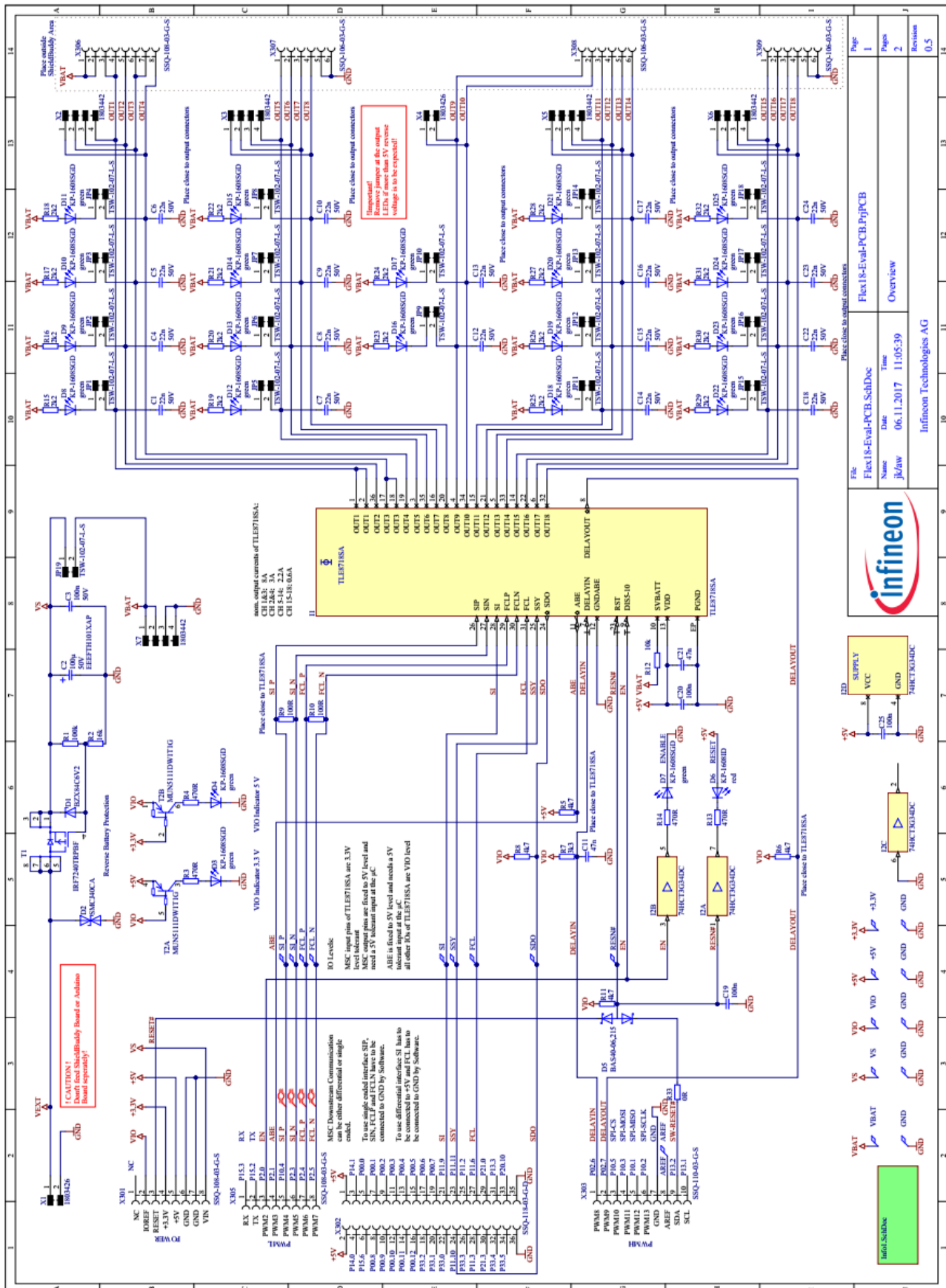

Figure 1-13 Schematic of TLE8718SA evaluation board

# Multi-channel Low-Side Switching ICs

## Evaluation Kits for TLE9104SH, TLE8110ED and TLE8718SA

### Hardware Configuration

#### 1.4 Connection Board

The connection board (seen in Figure 1-15) is a powerful tool which interfaces between the evaluation boards of the TLE9104SH, TLE8110ED and TLE8718SA on one side, and the TC277 microcontroller Triboard on the other. It is a comprehensive test platform for the three multi-channel switching ICs. This connection board can be divided into five main sections:

- A. Connections to the TLE9104SH evaluation board
- B. Connections to the TLE8110ED evaluation board
- C. Connections to the TLE8718SA evaluation board
- D. Connections to the TC277 Triboard.
- E. Power Connection.

The diagram of the connection board is illustrated in Figure 1-14, showing the connections among different sections. Figure 1-15 shows a 3D picture of the connection board, where the position of each evaluation board is shown. The silkscreen diagram is given in Figure 3-1 in the Appendix of this manual.

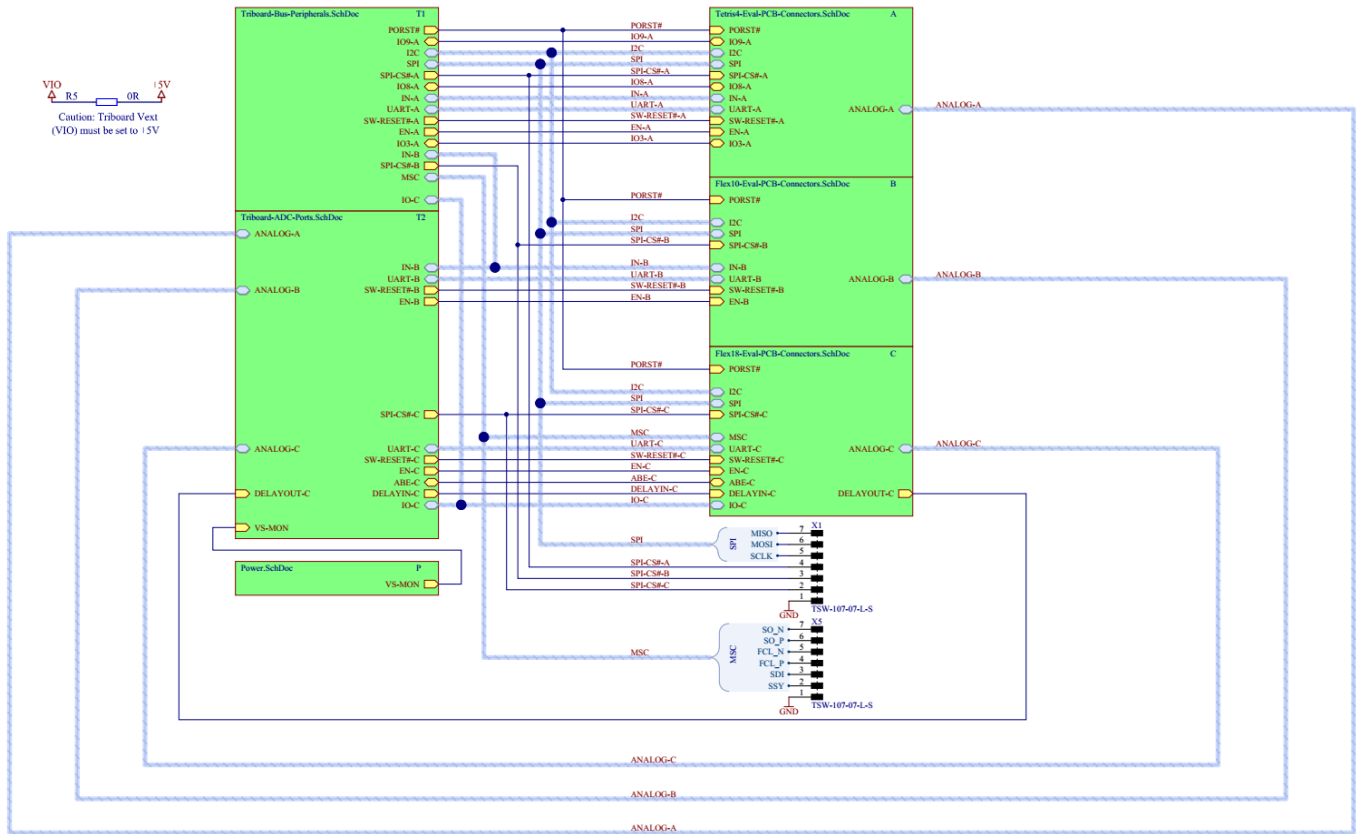

**Figure 1-14** Connections among different functional sections

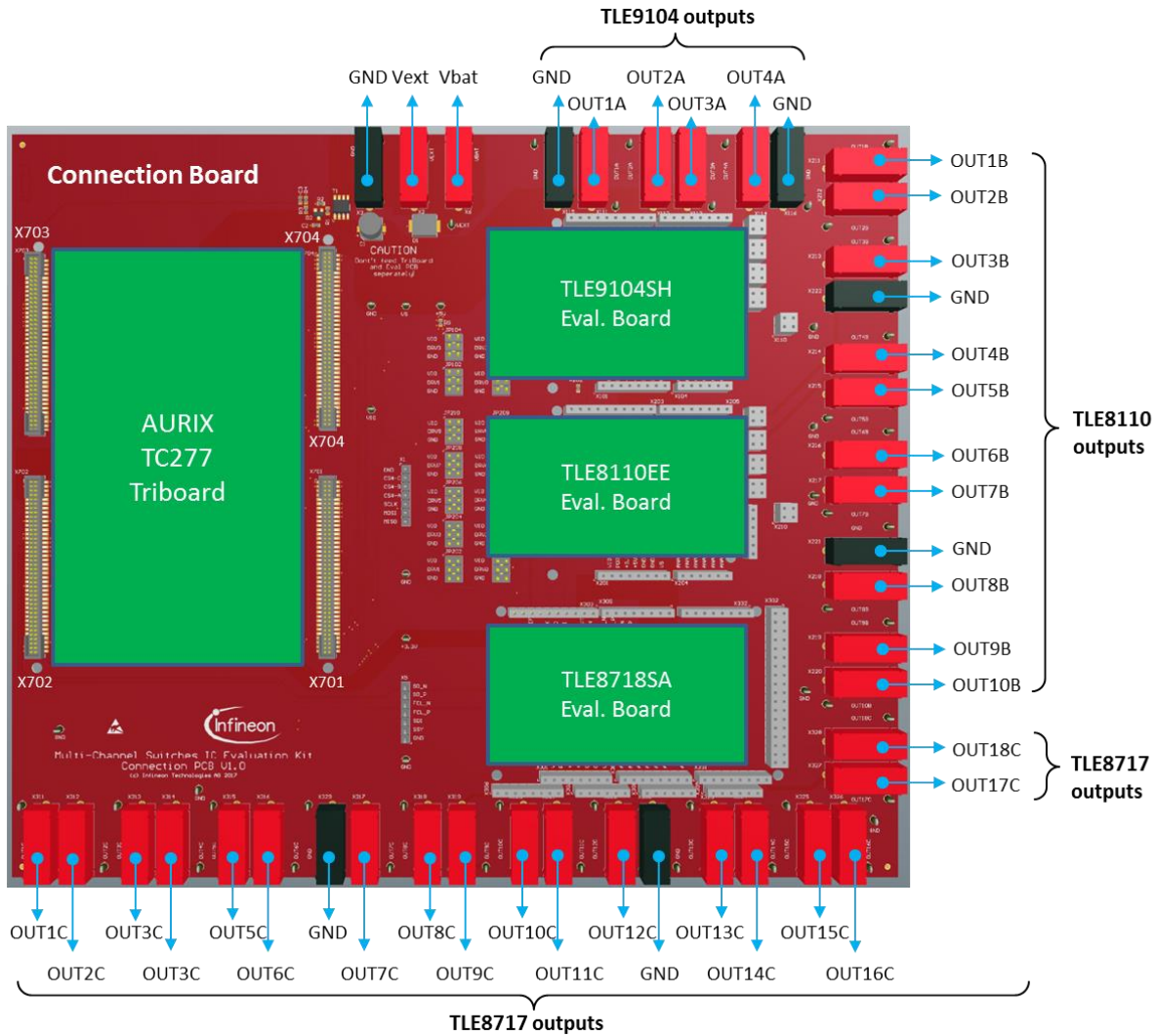

**Figure 1-15 Functional blocks and ports of the connection PCB**

**WARNING**

The Vext power rails on the three evaluation kits and the main connection board are linked together. Connecting two power supplies to two separate Vext connectors may damage the evaluation boards.

**1.4.1 Connections to TLE9104SH evaluation board**

The loads can be connected to the banana sockets (X111-X114) or finger sockets (X106-X110). The battery connection is available on each finger socket. Make sure the connector orientation is correct to avoid shorting the battery to the outputs of the switching IC. Nevertheless, if the connection is not made properly, a short-circuit protection in the IC would prevent further damage.

**Jumpers**

#### Hardware Configuration

Besides connecting the input signals (IN1-A to IN4-A) from the microcontroller, jumpers JP101-JP104 also provide the option to pull up or down the input signals of the TLE9104SH IC, to Vext or GND respectively.

# Multi-channel Low-Side Switching ICs

## Evaluation Kits for TLE9104SH, TLE8110ED and TLE8718SA

### Hardware Configuration

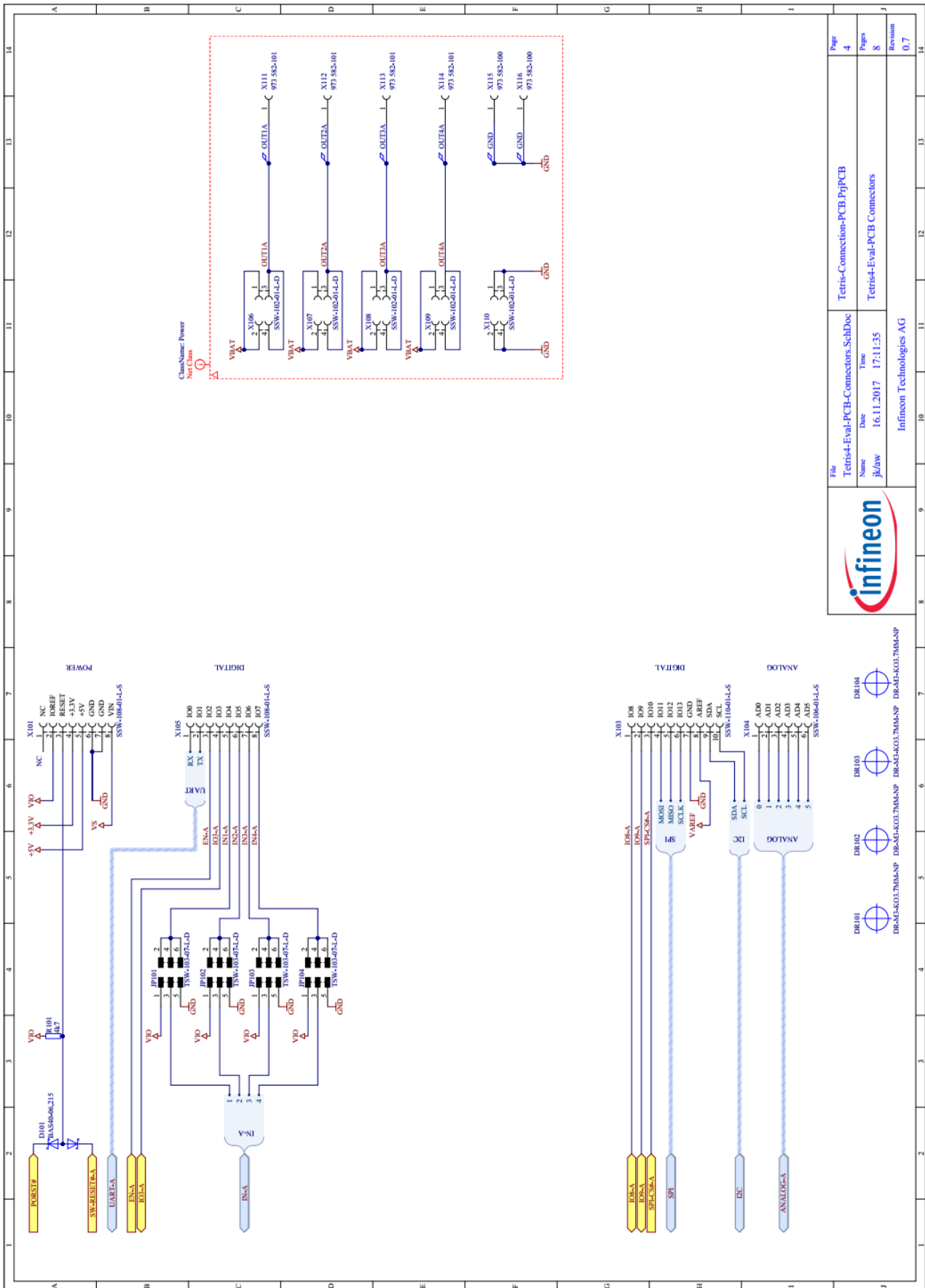
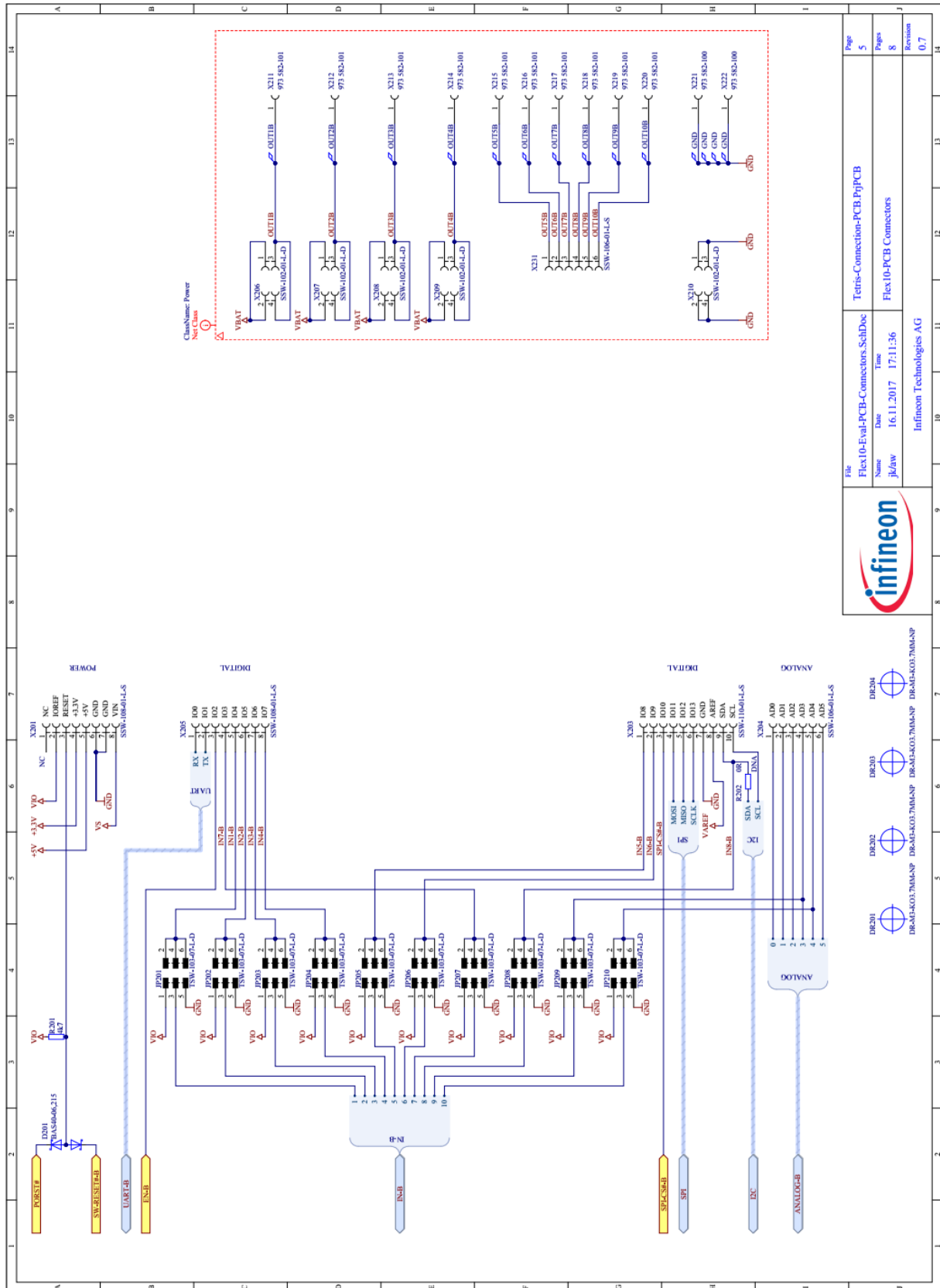

Figure 1-16 Connections to TLE9104SH evaluation board

### 1.4.2 Connections to TLE8110ED evaluation board

The connection from the connection PCB to TLE8110ED evaluation board is similar to that of the TLE9104SH.



**Figure 1-17 Connections to TLE8110ED evaluation board**

# Multi-channel Low-Side Switching ICs

## Evaluation Kits for TLE9104SH, TLE8110ED and TLE8718SA

### Hardware Configuration

### 1.4.3 Connections to TLE8718SA evaluation board

The wiring from the connection PCB to the TLE8718SA evaluation board is shown in Figure 1-18.

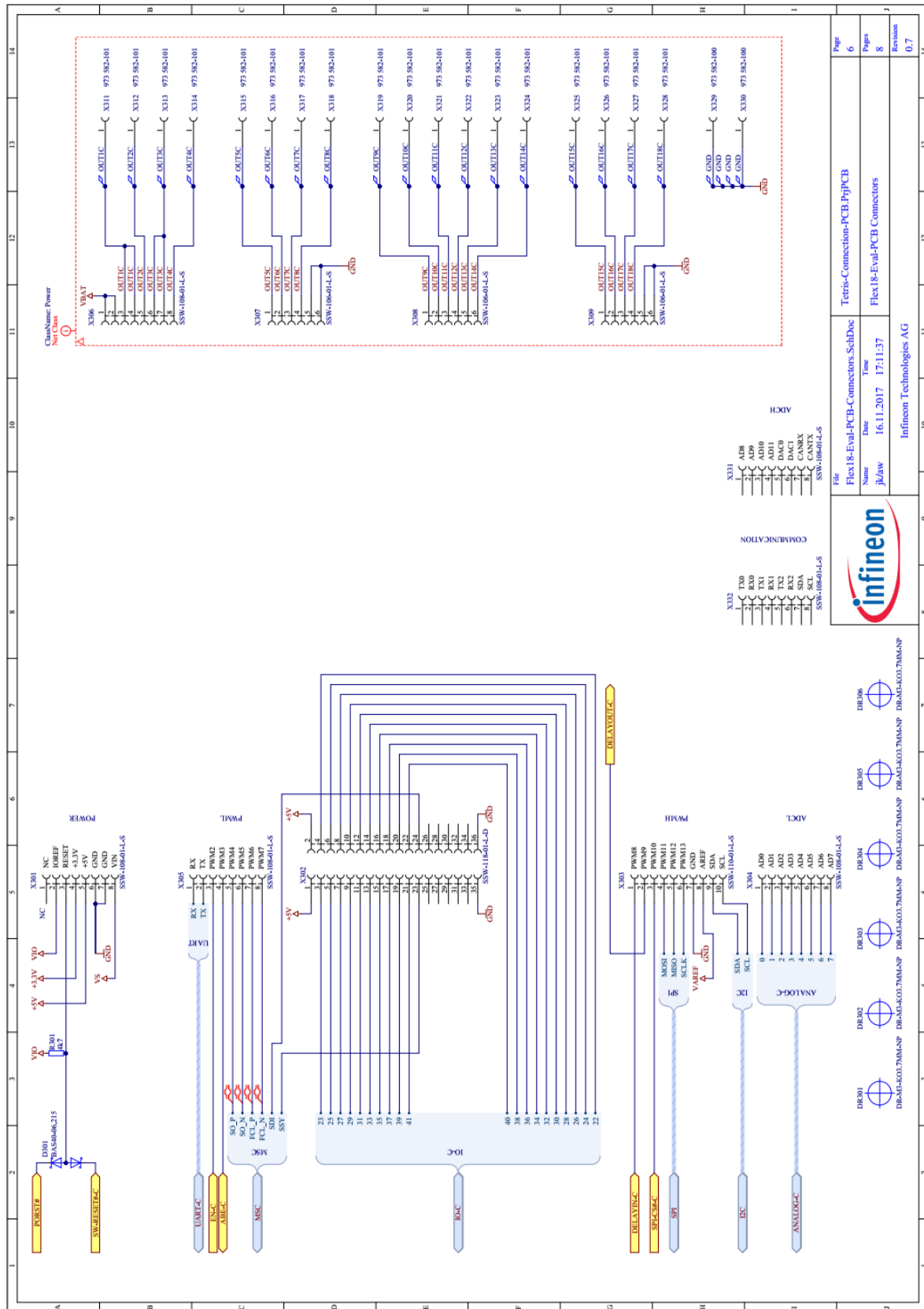
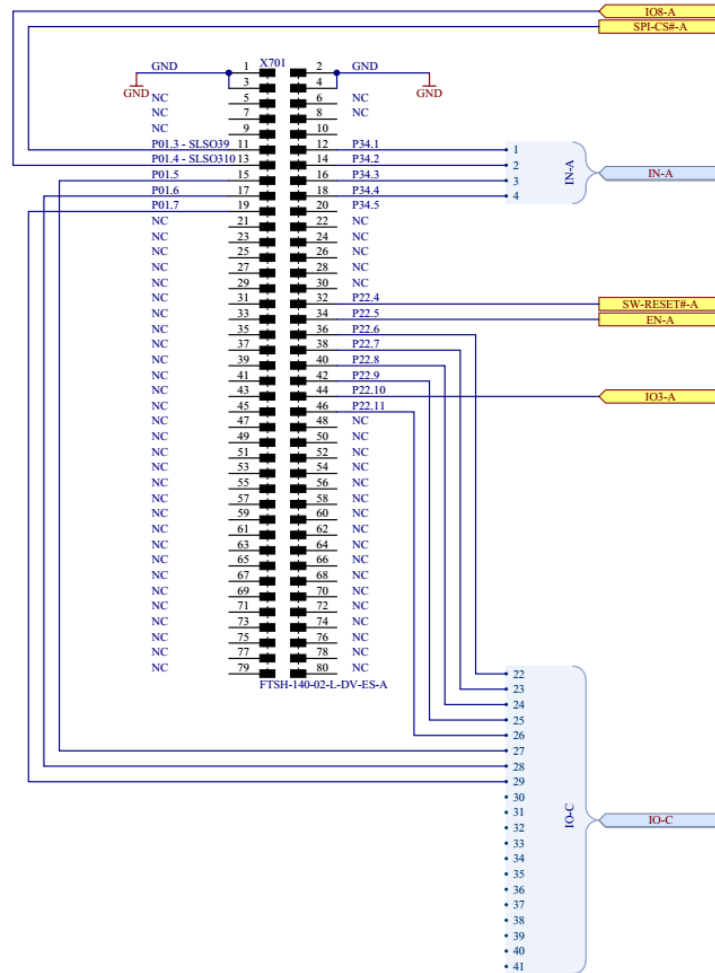

**Figure 1-18** Connections to TLE8718SA evaluation board

**Hardware Configuration**

**1.4.4 Connections to TC277 Triboard**

The power rails on the connection board to the TC277 Triboard are illustrated in Figure 1-19, Figure 1-20 and Figure 1-21.



**Figure 1-19 X701 connector from the connection PCB to the TC277 Triboard**



# Multi-channel Low-Side Switching ICs

## Evaluation Kits for TLE9104SH, TLE8110ED and TLE8718SA

### Hardware Configuration

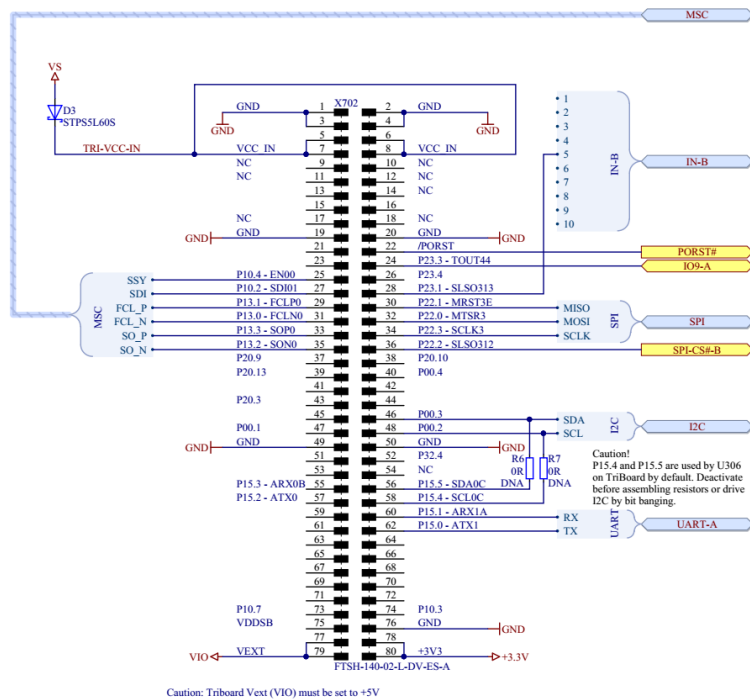

Figure 1-20 X702 connector from the connection PCB to the TC277 Triboard

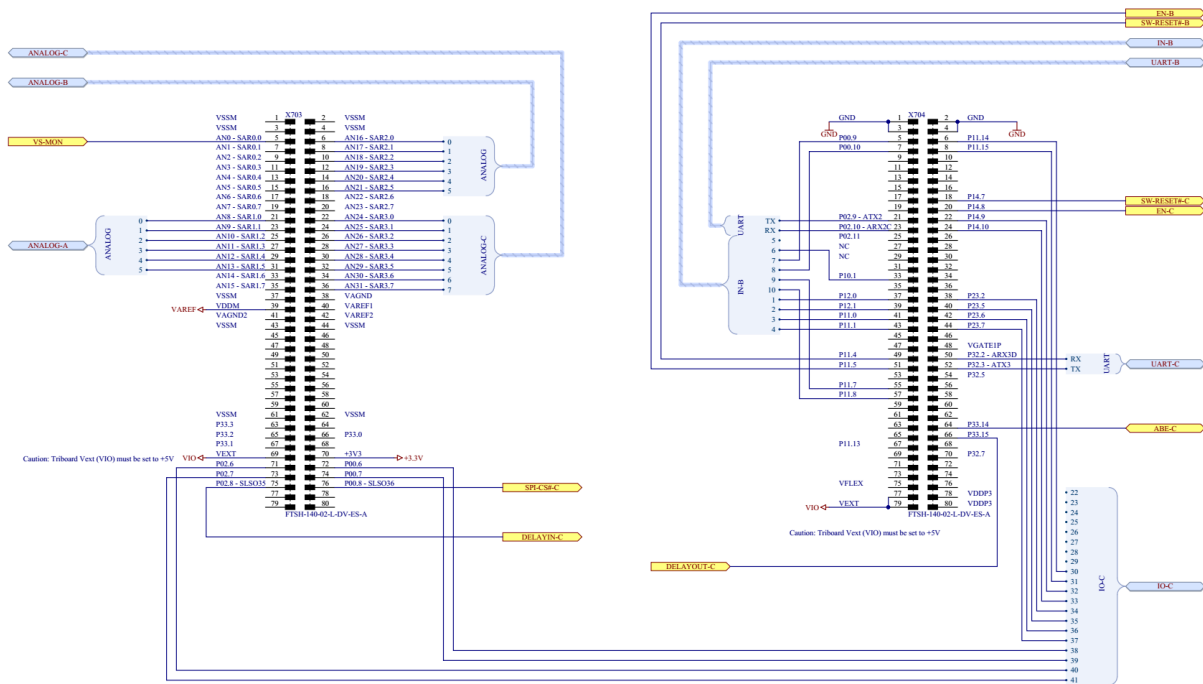

Figure 1-21 X703 and X704 connectors from the connection board to the TC277 Triboard

Hardware Configuration

1.4.5 Supply and Battery Connection

Figure 1-22 shows the schematic of the external supply and battery connection.

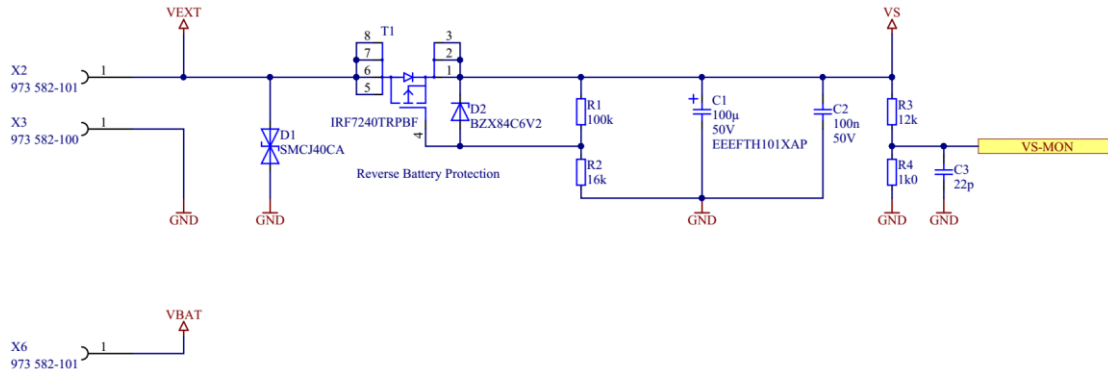

Figure 1-22 Supply and battery connection

**WARNING**

The Vext power rails on the three IC evaluation kits and the main connection board are linked together. Connecting two power supplies to two separate Vext connectors may damage the evaluation boards.

### Software

## 2 Software

The GUI can interface with the engine management IC evaluation boards either using the tri-slot common connection board (Figure 1-1) or using a single-slot Infineon microcontroller, such as the XMC1100. The common connection PCB can be used for testing the evaluation boards of all three ICs (TLE9104SH, TLE8110ED and TLE8718SA) simultaneously. Alternatively, utilizing the XMC1100 microcontroller board, it is possible to select one of the TLE9104SH or TLE8110ED evaluation kits at a time using the GUI.

### 2.1 Graphical User Interface (GUI)

The available GUI is used to interact with the evaluation boards. The GUI permits configuring the switching IC evaluation kits, specifying the PWM signal settings and reading/writing into the registers of the ICs.

#### 2.1.1 Main Window

After starting the GUI a dialog window will pop up (Figure 2-1). From the first drop-down menu select the connection PCB or the microcontroller board (XMC1100 or XMC4700) which is being used to interface with the switching IC evaluation kits. Based on the first selection of either a common connection PCB or XMC1100 microcontroller board, it is possible to test either three or one evaluation board respectively. If the common connection PCB was first chosen, the three IC evaluation boards being used should be selected for each slot from the three subsequent drop-down menus. Alternatively, if the XMC1100 is the tool of choice, then the user can only select one of the TLE9104SH or TLE8110ED evaluation kits for *Slot A* in the dialog window shown in Figure 2-1.

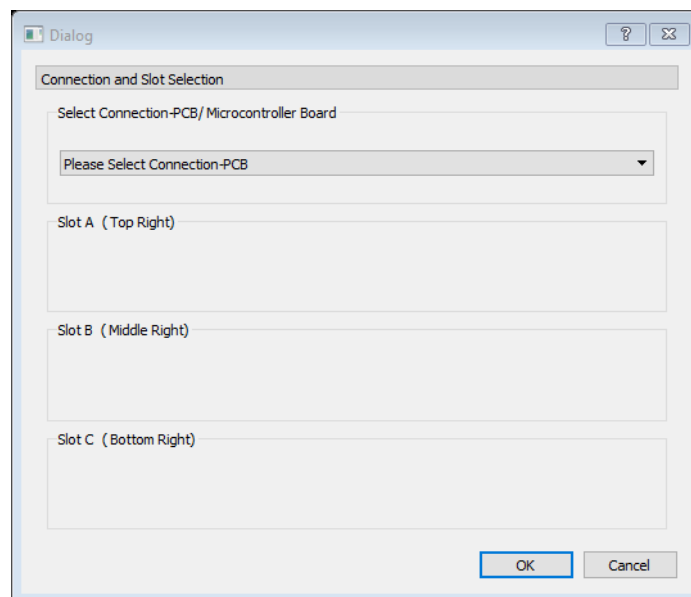

**Figure 2-1 Slot selection for the Connection PCB**

After selecting the connection-PCB or microcontroller board from the first drop-down menu, a prompt pops up for selecting the COM port for the USB- Serial interface (Figure 2-2). Locate the correct port in the 'Ports' section of the Device Manager on your PC's Control Panel.

Software

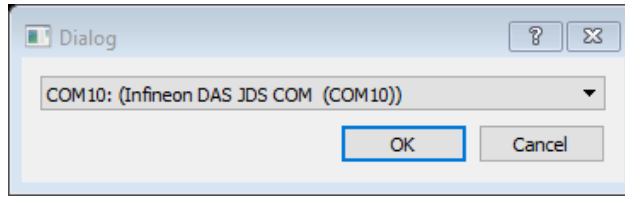

Figure 2-2 COM port selection

Once the correct COM port is identified and the three evaluation kits are selected (Figure 2-1), the GUI starts up in its default state. Figure 2-3 shows some of the main features of the main window.

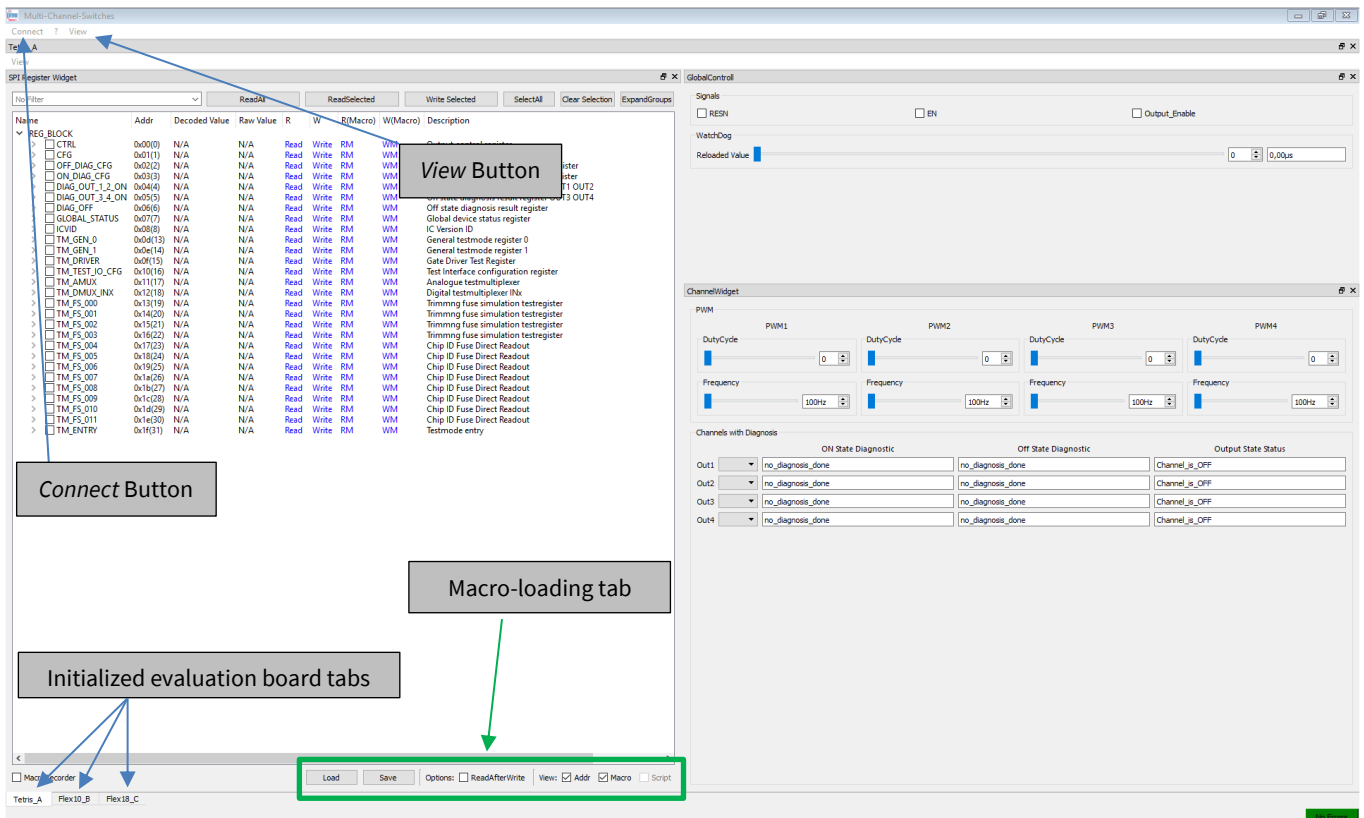

Figure 2-3 Main window overview

The *Connect* button in the top left corner opens the slot-selection menu. Next to it is the *View* menu which offers different layout options for the main window, such as hiding certain widgets or tabs, as well as saving the layout preferences. The bottom left corner has three buttons for switching across the three tabs corresponding to the three evaluation boards.

One useful feature of this GUI is its ability to load and run a user-written macro sequence, as an alternative to utilizing the evaluation board tabs (detailed in section 2.1.2). The user can write a command sequence to be loaded using the GUI, as shown in Figure 2-3, and executed by the IC. Appendix 3.2 provides a list of commands which can be used for writing a macro sequence.

# Multi-channel Low-Side Switching ICs

## Evaluation Kits for TLE9104SH, TLE8110ED and TLE8718SA

### Software

#### 2.1.2 Evaluation Board Tabs

This section includes instructions for configuring the three engine management IC evaluation boards using the GUI.

##### 2.1.2.1 Tetris\_A (TLE9104SH)

The first tab to the left is the *Tetris\_A* tab, which configures the 4-channel TLE9104SH evaluation kit. It can be segmented into five distinct widgets (

Figure 2-4):

1. Global control
2. Channel widget
3. Output control
4. Diagnostics
5. SPI register widget

**Tetris4\_A: Evaluation board Tetris4 has been initialized on slot A.**

**Global control: General functions like Reset, Enable.**

**Output control: Turn the output channels on and off and assign a PWM signal from the 4 modules in Channel widget.**

**Diagnostic: Displays the state of the output channels read from the corresponding registers**

**Channel widget: select the desired duty cycle and frequency values for the PWM signals.**

**SPI register widget: Gives read and write access to the chip registers.**

Name	Addr	Decoded Value	Raw Value	R	W	R(Macro)	W(Macro)	Description
REG_BLOCK								
CTRL	0x00(0)	N/A	N/A	Read	Write	RM	WM	Output control register
CFG	0x01(1)	N/A	N/A	Read	Write	RM	WM	Configuration register
OFF_DIAG_CFG	0x02(2)	N/A	N/A	Read	Write	RM	WM	Off state diagnosis configuration register
ON_DIAG_CFG	0x03(3)	N/A	N/A	Read	Write	RM	WM	On state diagnosis configuration register
DIAG_OUT_1_2_ON	0x04(4)	N/A	N/A	Read	Write	RM	WM	On state diagnosis result register OUT1 OUT2
DIAG_OUT_3_4_ON	0x05(5)	N/A	N/A	Read	Write	RM	WM	On state diagnosis result register OUT3 OUT4
DIAG_OFF	0x06(6)	N/A	N/A	Read	Write	RM	WM	Off state diagnosis result register
GLOBAL_STATUS	0x07(7)	N/A	N/A	Read	Write	RM	WM	Global device status register
ICVID	0x08(8)	N/A	N/A	Read	Write	RM	WM	IC Version ID
TM_GEN_0	0x0d(13)	N/A	N/A	Read	Write	RM	WM	General testmode register 0
TM_GEN_1	0x0e(14)	N/A	N/A	Read	Write	RM	WM	General testmode register 1
TM_DRIVER	0x0f(15)	N/A	N/A	Read	Write	RM	WM	Gate Driver Test Register
TM_TEST_IO_CFG	0x10(16)	N/A	N/A	Read	Write	RM	WM	Test Interface configuration register
TM_AMUX	0x11(17)	N/A	N/A	Read	Write	RM	WM	Analogue testmultiplexer
TM_DMUX_INK	0x12(18)	N/A	N/A	Read	Write	RM	WM	Digital testmultiplexer Ibk
TM_FUSE_000	0x13(19)	N/A	N/A	Read	Write	RM	WM	Trimming fuse simulation testregister
TM_FUS_001	0x14(20)	N/A	N/A	Read	Write	RM	WM	Trimming fuse simulation testregister
TM_FUS_002	0x15(21)	N/A	N/A	Read	Write	RM	WM	Trimming fuse simulation testregister
TM_FUS_003	0x16(22)	N/A	N/A	Read	Write	RM	WM	Trimming fuse simulation testregister
TM_FUS_004	0x17(23)	N/A	N/A	Read	Write	RM	WM	Chip ID Fuse Direct Readout
TM_FUS_005	0x18(24)	N/A	N/A	Read	Write	RM	WM	Chip ID Fuse Direct Readout
TM_FUS_006	0x19(25)	N/A	N/A	Read	Write	RM	WM	Chip ID Fuse Direct Readout
TM_FUS_007	0x1a(26)	N/A	N/A	Read	Write	RM	WM	Chip ID Fuse Direct Readout
TM_FUS_008	0x1b(27)	N/A	N/A	Read	Write	RM	WM	Chip ID Fuse Direct Readout
TM_FUS_009	0x1c(28)	N/A	N/A	Read	Write	RM	WM	Chip ID Fuse Direct Readout
TM_FUS_010	0x1d(29)	N/A	N/A	Read	Write	RM	WM	Chip ID Fuse Direct Readout
TM_FUS_011	0x1e(30)	N/A	N/A	Read	Write	RM	WM	Chip ID Fuse Direct Readout
TM_ENTRY	0x1f(31)	N/A	N/A	Read	Write	RM	WM	Testmode entry

Figure 2-4 Tetris\_A (TLE9104SH) GUI tab

- To start the *Tetris* evaluation board from the global control widget, the following sequence is recommended:
  1. If the RESET LED on the evaluation board is on, untick then tick again the *RESN* checkbox on the GUI.
  2. Tick the *EN* checkbox.
  3. Tick the *Output\_Enable* checkbox.

Additionally, the watchdog value can be modified using the slider on the global control widget. The watchdog is, however, triggered properly at startup and does not need to be configured.

- The *channel* widget permits setting specific values for duty cycle and frequency for the four PWM signals which can be generated.
- The *output* control widget (marked in purple in ) is used to assign any of the four PWM signals to each of the four output channels.
- The *SPI register* widget gives read and write access to the chip registers.
- The *Diagnostics* widget displays the state of the output channels read from the corresponding registers. The following sequence is recommended:
  1. In the *SPI register* widget: “REG\_BLOCK” → “DIAG\_ON\_1\_2\_ON”, click on the corresponding *Read* button.
  2. In the *SPI register* widget: “REG\_BLOCK” → “DIAG\_ON\_3\_4\_ON”, click on the corresponding *Read* button.
  3. In the *SPI register* widget: “REG\_BLOCK” → “DIAG\_OFF”, click on the corresponding *Read* button.

The on-state and off-state diagnostics can be seen in the *Diagnostics* widget.

Software

### 2.1.2.2 Flex10\_B (TLE8100ED)

On the *Flex10\_B* tab, the 10-channel TLE8100ED evaluation kit can be configured and operated, as shown in Figure 2-5. The widgets on the *Flex10\_B* tab are similar to those of the *Tetris\_A* tab which are explained in section 2.1.2.1.

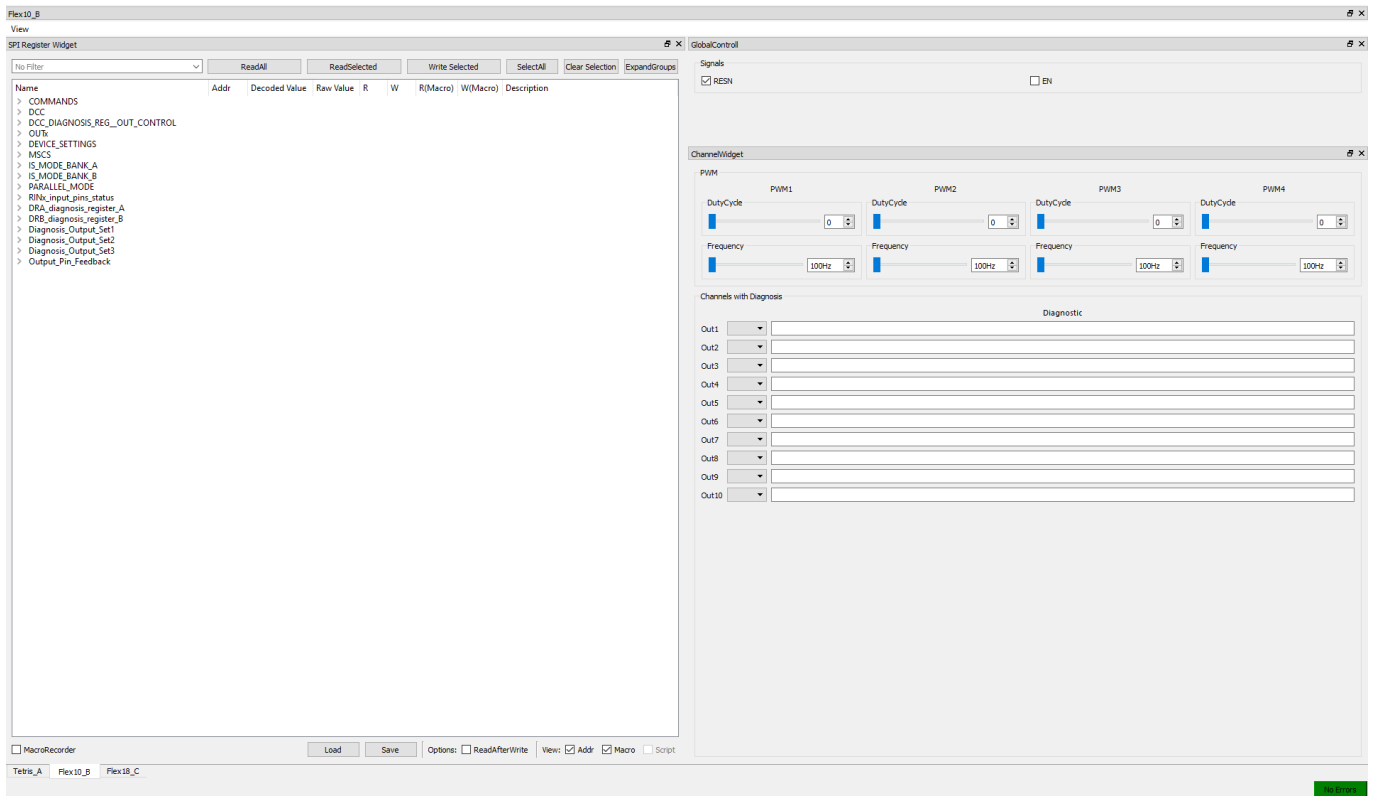

Figure 2-5 Flex10 (TLE8100ED) GUI tab

- To start the *Flex10* evaluation board from the global control widget:
  1. Tick the *RESN* checkbox.
  2. Tick the *EN* checkbox.
- Specify the desired duty cycle and frequency values for one or all of the PWM signals in the *Channel* widget.
- Assign the specified PWM signals to the output channels using the drop-down buttons (*Out1* to *Out10*) in the *Channels with Diagnosis* widget.
- To issue the diagnostics of the output channels, the following sequence is recommended:
  1. In the *SPI register* widget: “DRA\_diagnosis\_register\_A” → “DRA\_diagnosis\_register\_A” → Click on the corresponding **Write** button.
  2. In the *SPI register* widget: “DRB\_diagnosis\_register\_B” → “DRB\_diagnosis\_register\_B” → Click on the corresponding **Write** button.

**Software**

The on-state and off-state diagnostics can be seen in the *Diagnostics* widget.

**2.1.2.3 Flex18 (TLE8718SA)**

The 18-channel low-side power switch TLE8100ED’s evaluation kit can be configured and operated on the *Flex18\_C* tab, shown in Figure 2-6. The widgets on the *Flex18\_C* tab are similar to those of the *Tetris\_A* tab which were explained in section 2.1.2.1.

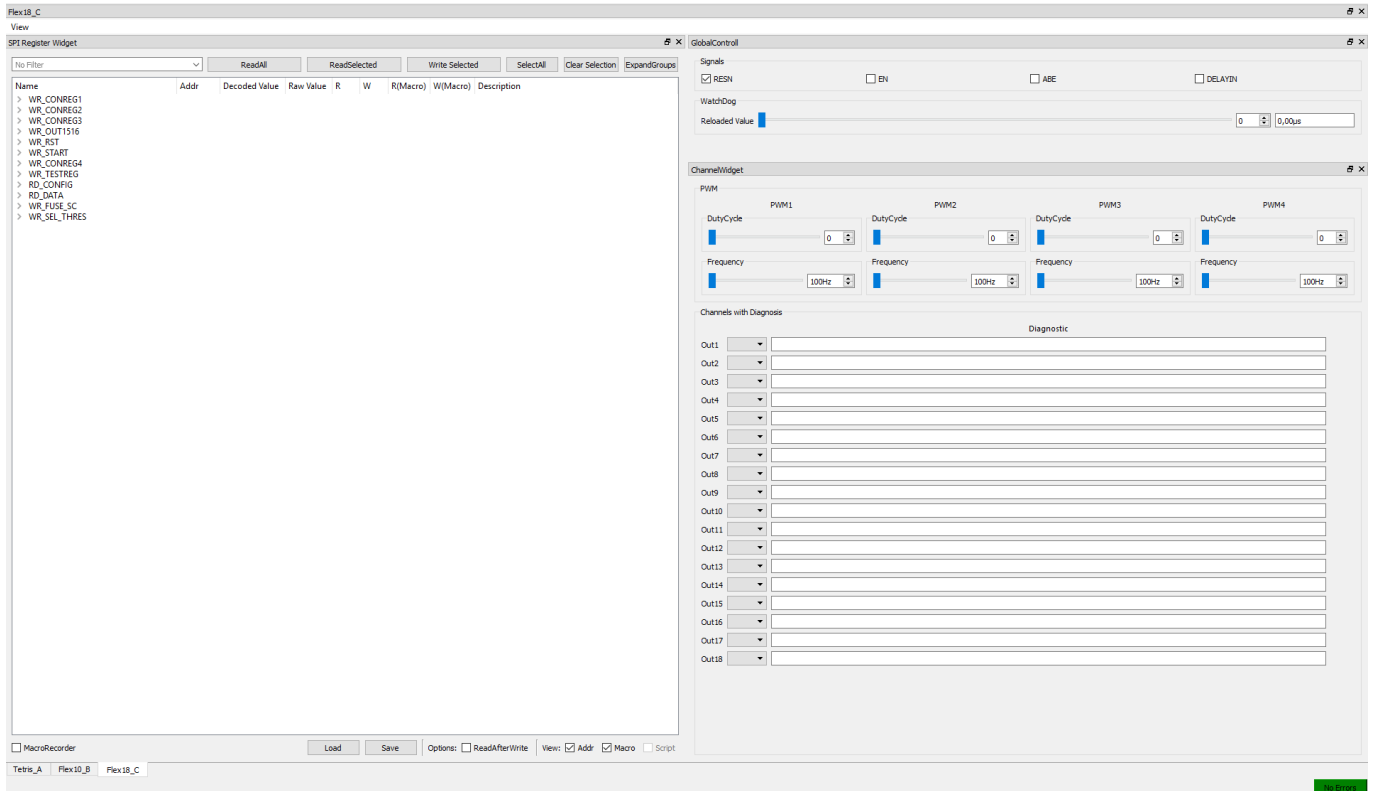

**Figure 2-6 Flex18 (TLE8118SA) GUI tab**

- To start the *Flex18* evaluation board from the global control widget:
  1. Tick the *RESN* checkbox.
  2. Tick the *EN* checkbox.
  3. Tick the *ABE* checkbox.
  4. Tick the *DELAYIN* checkbox.

The watchdog value can be modified using the slider on the global control widget. However, the watchdog is triggered properly at startup and does not need to be configured.

- Specify the desired duty cycle and frequency values for one or all of the PWM signals in the *Channel* widget.
- Assign the specified PWM signals to the output channels using the drop-down buttons (*Out1* to *Out18*) in the *Channels with Diagnosis* widget.
- To issue the diagnostics of all 18 output channels:  
 In the *SPI register* widget: “RD\_Data” → “REG”, click on the corresponding *Read* buttons.  
 The on-state and off-state diagnostics can be seen in the *Diagnostics* widget.



**Software**

**2.2 Microcontroller Flashing**

**2.2.1 Flashing Aurix**

Flashing Aurix-Family Microcontrollers is done via the Infineon-Memtool which can be downloaded from the Infineon Website.

Once installed open Memtool. You will be greeted by a screen like this:

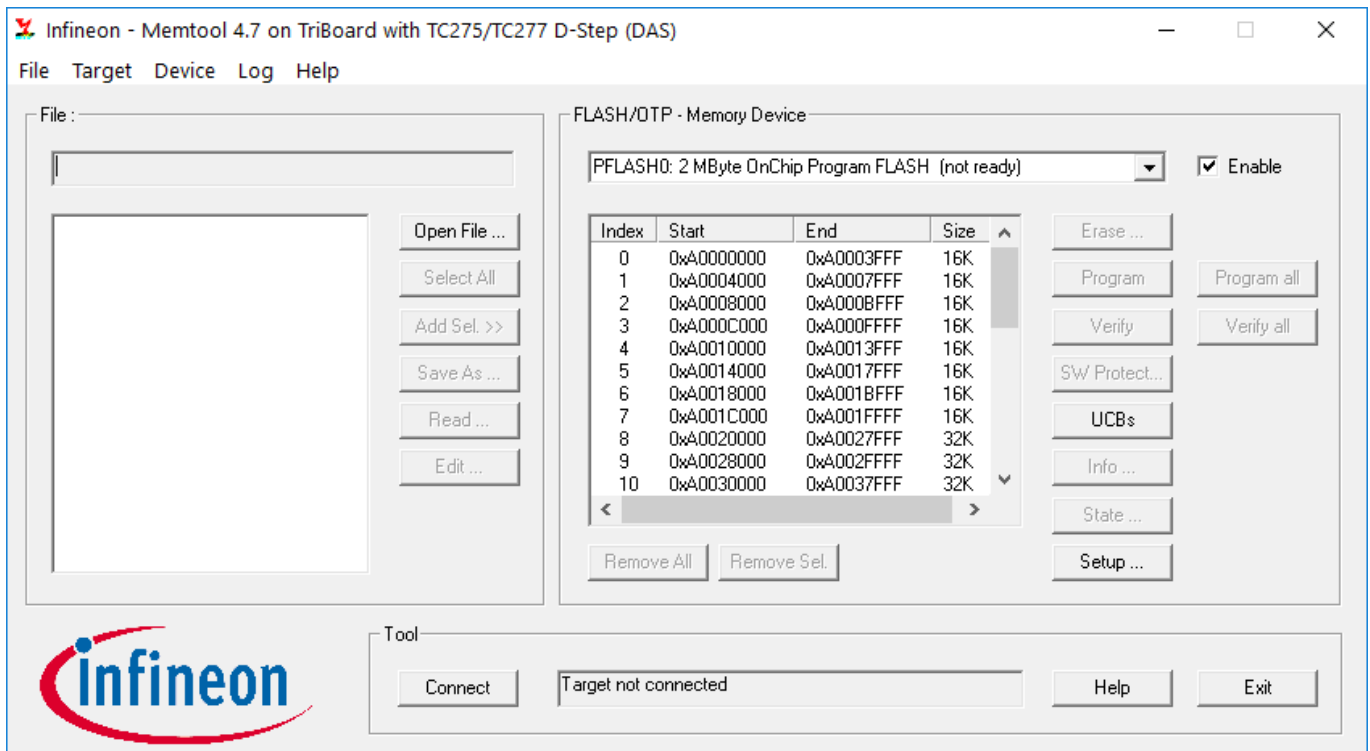

**Software**

The next step is to select Target -> Change... from the drop down menu:

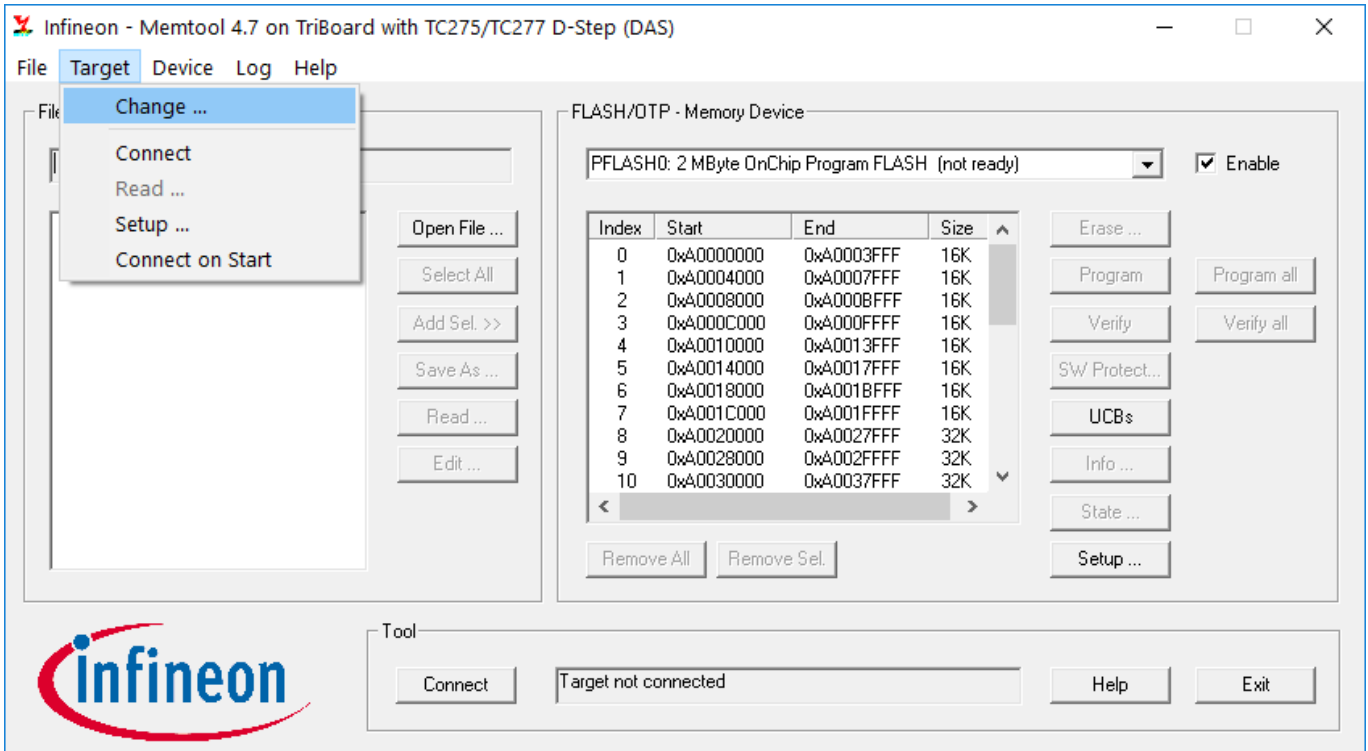

Which brings up this screen:

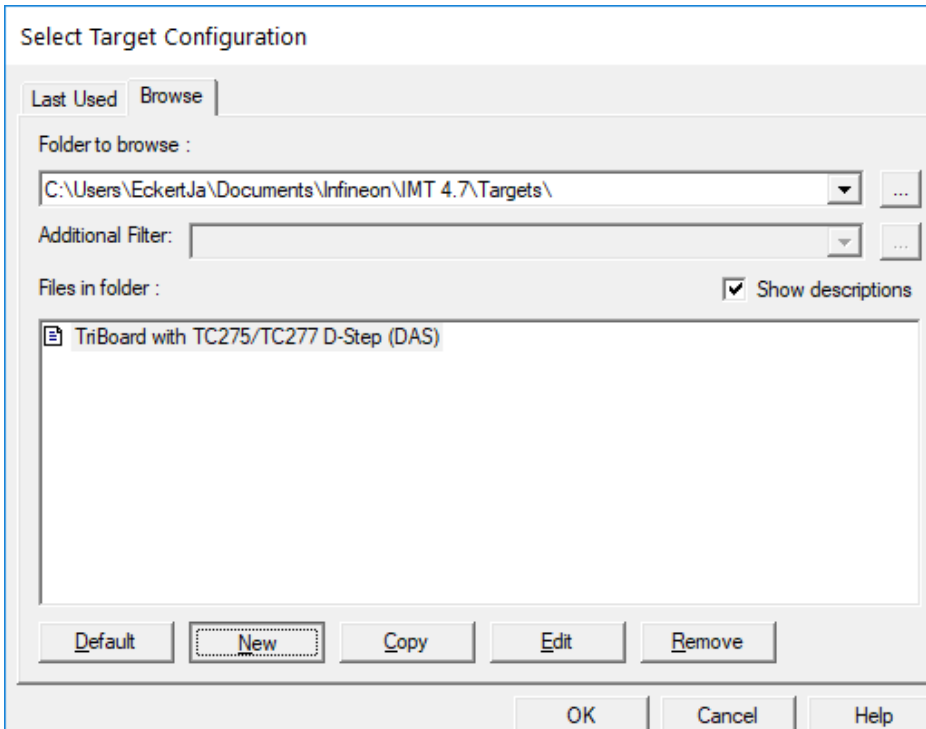

**Software**

Select “New”, which brings up the Board-Selector:

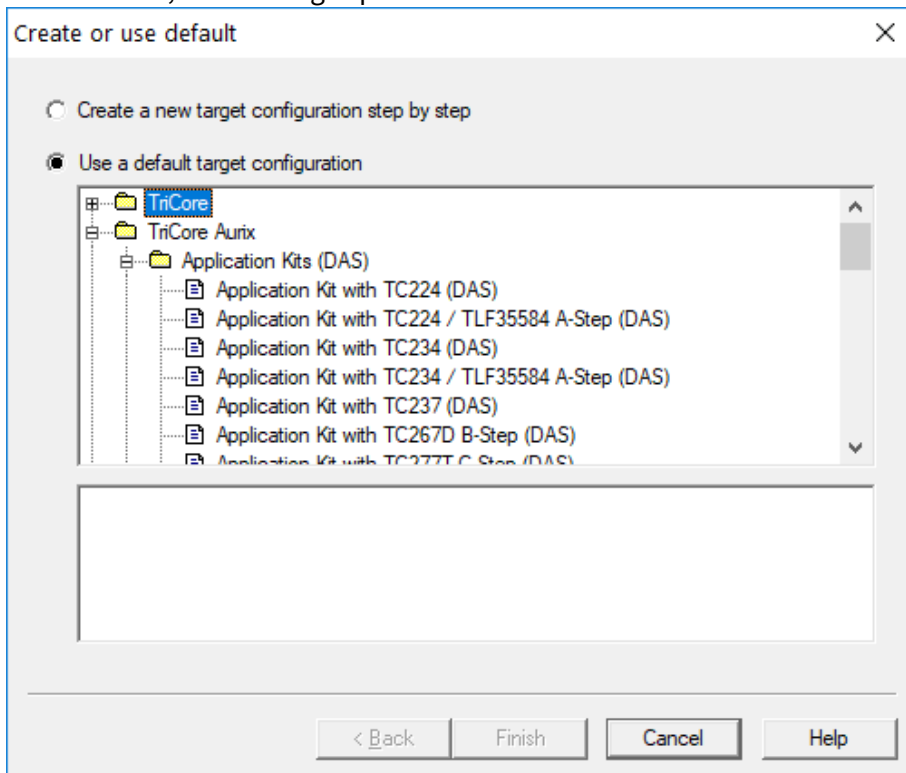

Select “Use default target configuration” on the top and then in the Box below:  
 Tricore Aurix -> Application Kits (DAS) -> Application Kit with TC277T D-Step (DAS)

After confirming the selection you are asked to save the target config file. Afterwards you can go back to the main screen. Click the “connect” button to establish a connection to the Board. The Label next to the connect-button will read “Ready for Memtool Command” once successfully connected. Next click the “Open File...” button and select an appropriate .hex file for programming.

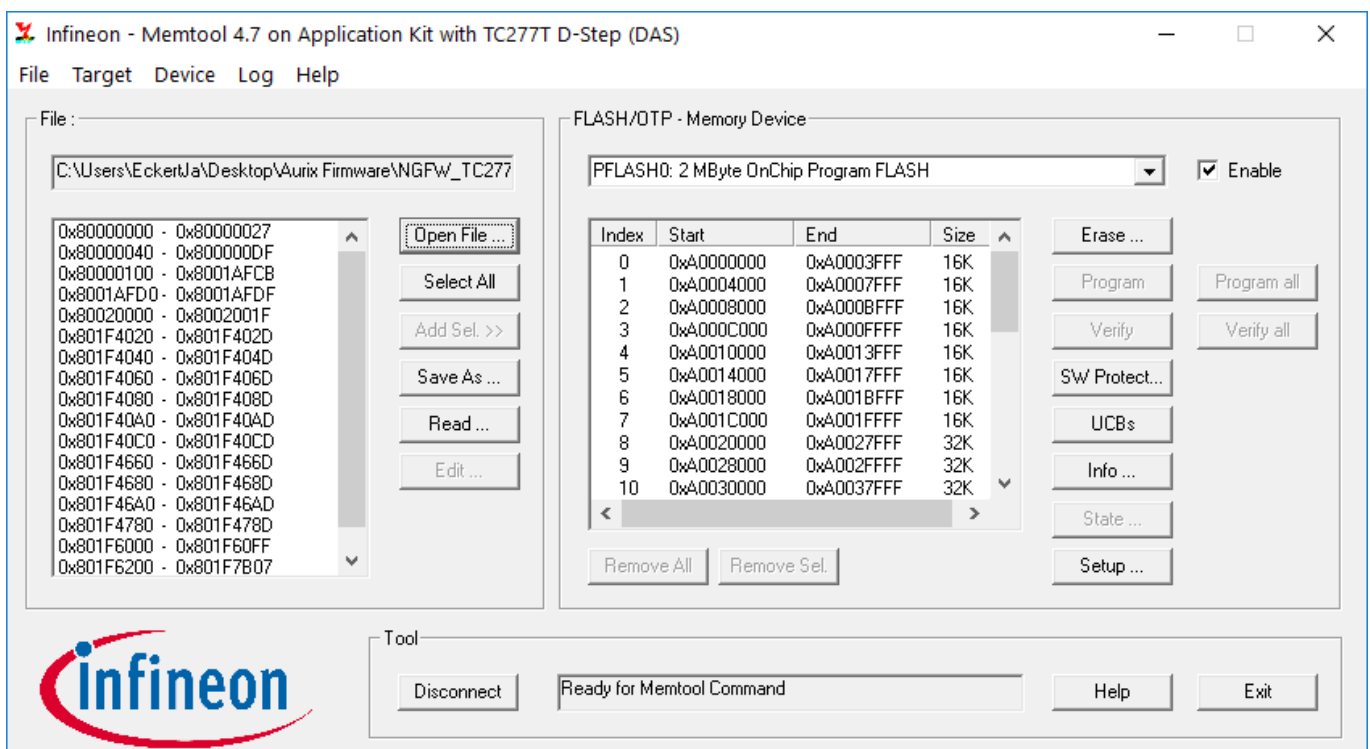

**Software**

Then click on “Select All”. Now “Add Sel” will be clickable. After clicking on that press program and the programming process will begin. Once done programming, a success message will be displayed.

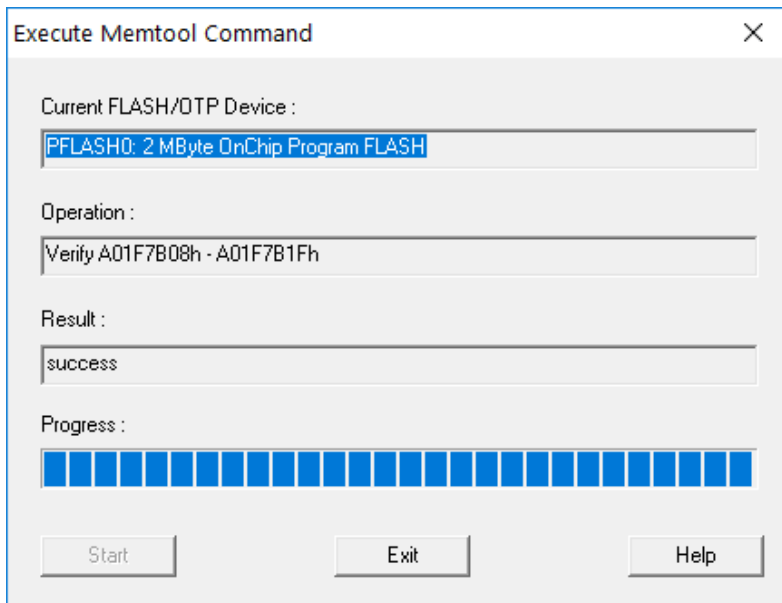

**Software**

**2.2.2 Flashing XMC1100**

Flashing XMC1100 Microcontroller is done via the J-Link Flash lite which can be obtained from the segger website.

Upon opening JLink Flash lite, this screen comes up:

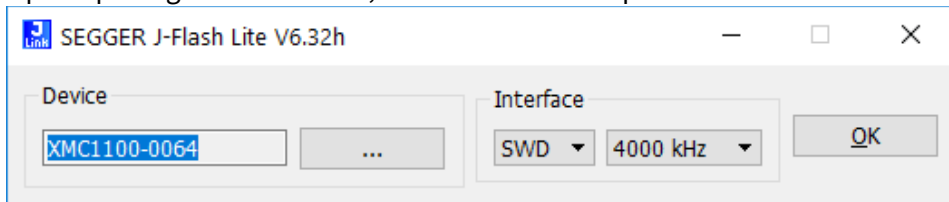

To select your device (The XMC1100-0064), press the button with the three dots on it. It brings up this menu. Here you select the XMC1100-0064 and press ok.

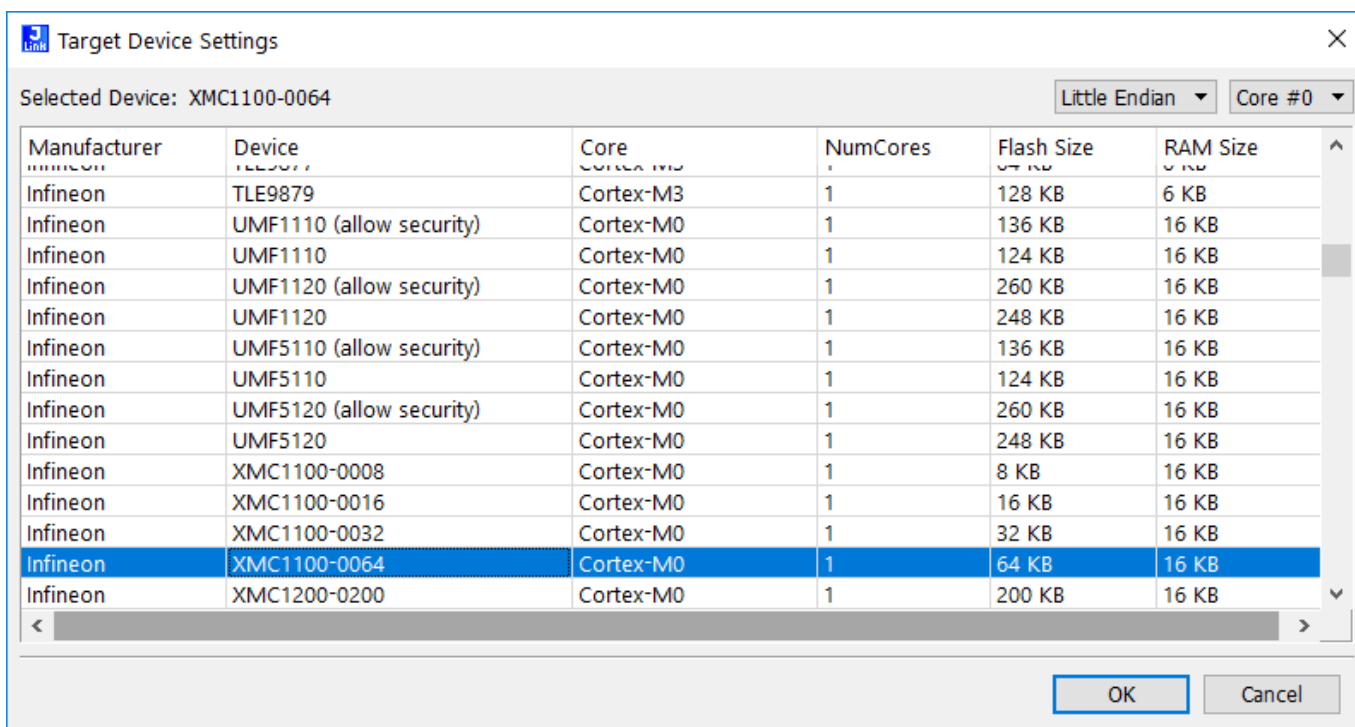

## Multi-channel Low-Side Switching ICs

### Evaluation Kits for TLE9104SH, TLE8110ED and TLE8718SA

#### Software

This brings you back to the first screen but now the right device is selected, which means you can proceed by pressing ok. This opens the programming-screen. Press the three dots-button to select an appropriate hex-file for programming. Afterwards selected press “Program device” and the flashing procedure starts.

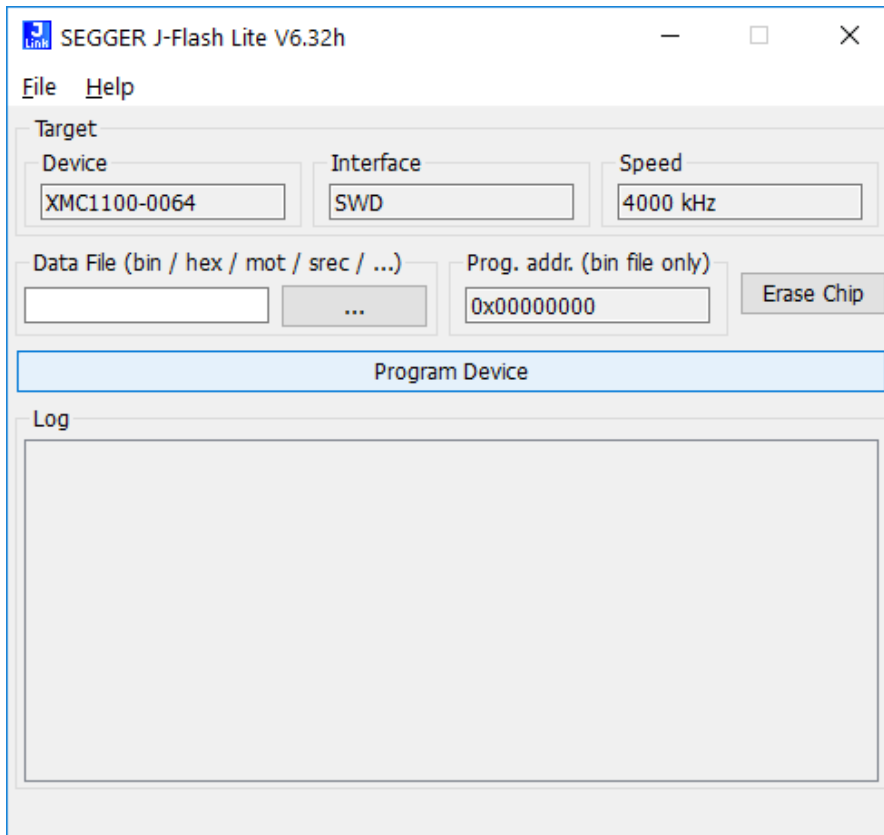

Once done, J-Link shows a success-message:

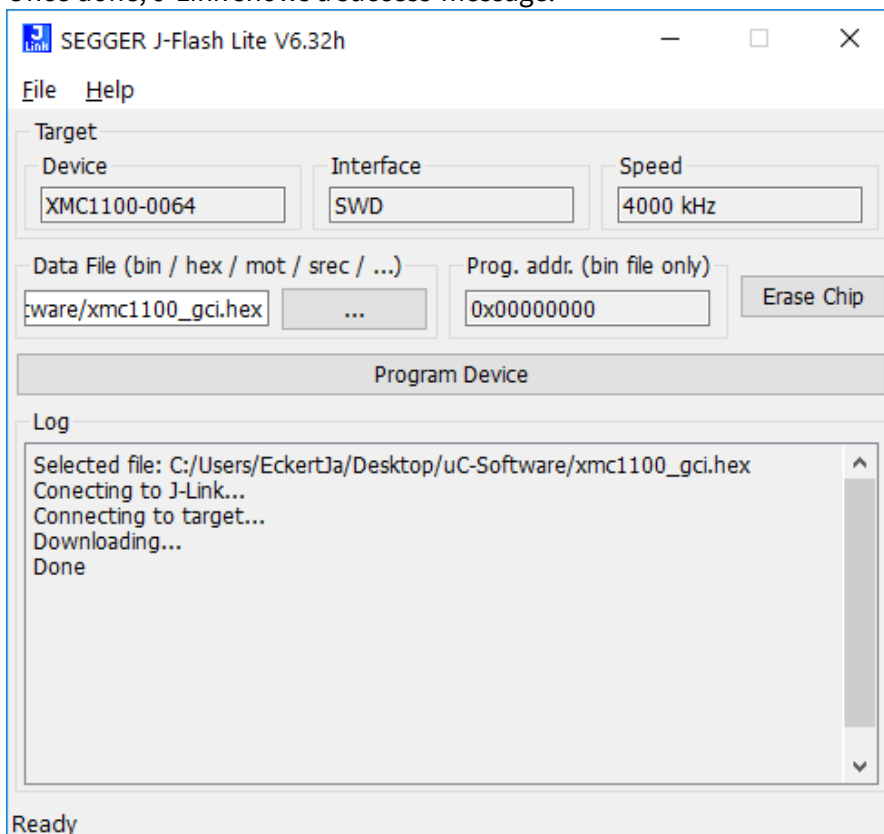

Appendix

### 3 Appendix

#### 3.1 Common Connection PCB Schematic

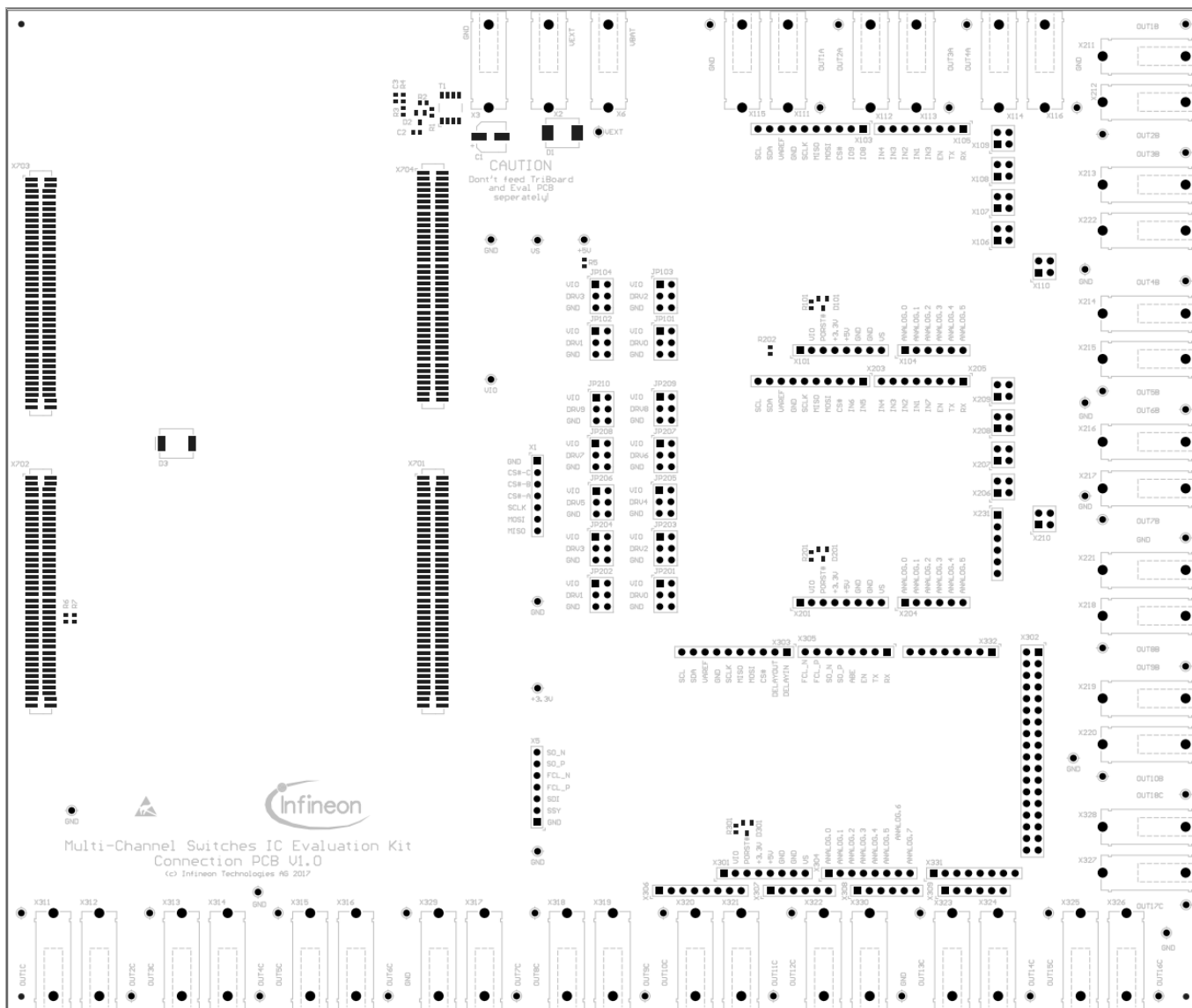

Figure 3-1 Common connection PCB schematic

#### 3.2 Command List

This appendix section provides a list of commands which can be used for writing a macro sequence to be loaded for execution using the GUI as explained in section 2.1.1.

##### 3.2.1 General Information

- All values have to be typed in as hexadecimal numbers. If the first digit is alphabetic, a zero has to be typed in front of the value.
- The Connection-PCB is initialized on startup. Make sure that you are using the correct Hex File. The type of Connection-PCB is displayed on startup or when entering the *help()* command.

### Appendix

- For most commands a slot number (slot) has to be entered. Slot 0 selects the connection PCB. The Eval-PCBs are enumerated from top (1) to bottom (3) on the common-connection PCB. The XMC1100 has a single slot (1) only.
- Not all Eval-PCBs can be mounted on every slot. The user can initialize Eval-PCBs by the initialization commands and the slot number. The type of initialized Eval-PCBs is displayed when entering the `help()` command.
- CRCs, Parity Bits or similar have to be calculated by the user.
- Bus speeds are depending on the maximum value specified in the datasheet of the particular slave device.

### 3.2.2 Initialization Commands

- `InitEvalTetris4(slot)` – Engine-Management-Connection-PCB (slot 1 or 2), Microcontroller board slot 1.
- `InitEvalFlex10(slot)` – Engine-Management-Connection-PCB (slot 2), Microcontroller board slot 1.
- `InitEvalFlex18(slot)` – Engine-Management-Connection-PCB (slot 3), Microcontroller board slot 1.

### 3.2.3 List of Commands

- `help()` – help  
Displays board info, names and command list.  
Returns 0 always.
- `cmdrep()` - command repetition  
Sets last command to prompt again if activated.  
Toggles without parameter.  
Returns 0 always.
- `debug(state)` - debug mode  
Prints some debug information if activated.  
Returns state.  
Expected values:
  - state: [0] or [1]
- `delay(ticks)` - delay  
Waits for ticks time in milliseconds.  
Returns ticks.  
Expected values:
  - ticks: [0x1] to [FFFFFFFF]
- `ior(slot, ioDev)` - io read  
Returns state of input or output ioDev, if successful.  
Expected values:
  - slot: [0] to [3], depending on the initialized boards
  - ioDev: Names displayed in help command or XMC1100 Bootkit IO numbers depending on the initialized boards



**Appendix**

- **iow(slot, ioDev, outState) - io write**  
Writes outState to output ioDev.  
Returns outState, if successful.  
Expected values:
  - slot: [0] to [3], depending on the initialized boards
  - ioDev: Names displayed in help command or XMC1100 Bootkit IO numbers depending on the initialized boards
  - outState: [0] or [1]
  
- **iop(slot, ioDev, outState, ticks) - io pulse**  
Sets ioDev to outState for the time of ticks ms, then sets ioDev to inverse outstate.  
Returns ioDev, if successful.  
Expected values:
  - Slot: [0] to [3], depending on the initialized boards
  - IoDev: Names displayed in help command or XMC1100 Bootkit IO numbers depending on the initialized boards
  - OutState: [0] or [1]
  - Ticks: [1] to [FFFFFFFF]
  
- **iowt(slot, ioDev, inState) - io wait**  
Waits until ioDev has the value of instate.  
Returns inState, if successful.  
Expected values:
  - slot: [0] to [3], depending on the initialized boards
  - ioDev: Names displayed in help command or XMC1100 Bootkit IO numbers depending on the initialized boards
  - inState: [0] or [1]
  
- **msc(slot, mscDev, out, sb) - msc downstream**  
Sends a msc downstream frame with content out to device mscDev (normaly 0).  
Msc downstream frame is a data frame if selection bit sb is 0, otherwise a command frame will be sent.  
Returns out, if successful.  
Expected values:
  - slot: [0] to [3], depending on the initialized boards, msc is only available for slot [3] on Engine-Management-Connection-PCB yet
  - mscDev: only device [0] supported
  - out: [0] to [FFFF], only 16 bit output (17 bit - selection bit) supported
  - sb: [0] for data frame, [1] for command frame
  
- **mscs(slot, mscDev, out1, sb1, out2, sb2, ticks) - msc sequence**  
Sends two downstream frames with a delay of ticks ms.  
Out1 and sb1 first frame, out2 and sb2 second frame.  
Watchdog or pwm frames can be sent between both frames, if activated.  
Returns out2, if successful.  
Expected values:
  - slot: [0] to [3], depending on the initialized boards, msc is only available for slot [3] on Engine-Management-Connection-PCB yet
  - mscDev: only device [0] supported yet

### Appendix

- outx: [0] to [FFFF], only 16 bit output (17 bit - selection bit) supported yet
- sbx: [0] for data frame, [1] for command frame
- ticks: [1] to [FFFFFFFF]
- **mscr(slot, mscDev, out, numBytes) - msc read**

Sends a command frame with content out to mscDev to read registers.  
No selection bit because reading is possible with command frames, only.  
Waits for numBytes upstream frames.  
Returns received upstream data bytes as one 32-bit value; first received command is most significant byte.  
Expected values:

  - slot: [0] to [3], depending on the initialized boards, msc is only available for slot [3] on Engine-Management-Connection-PCB yet
  - mscDev: only device [0] supported yet
  - out: [0] to [FFFF], only 16 bit output (17 bit - selection bit) supported.
  - numBytes: [1] to [4]
- **mscp(slot, mscDev, frequency, dutyCycle, bitmask) - msc pwm**

Generates a pwm with bits in a msc data frame.  
Bitmask specifies the Flex18 stages to be influenced by the command (see Flex18 Datasheet for further information).  
Other commands are possible while msc pwm is running.  
Returns frequency, if successful.  
Expected values:

  - slot: [0] to [3], depending on the initialized boards, msc is only available for slot [3] on Engine-Management-Connection-PCB yet
  - mscDev: only device [0] supported yet
  - frequency: [0] (1Hz) to [4E20] (20kHz), [4E20] (20kHz) will be set for higher values, [0] turns off pwm for selected stages
  - dutyCycle: [0] (stages off) to [64] (stages on), both extreme values turn off pwm for the selected stages, duty Cycle may be less accurate for frequencies higher 2kHz
  - bitmask: [0] to [FFFF], example: [0007] is 0b111 and influences the last 3 stages given in the datasheet (at the moment OUT12, OUT14, OUT18).
- **pwm(slot, pwmDev, frequency, dutyCycle) - pwm**

Generates a pwm on an io number.  
I/O port has to be reconfigured for this and io commands are not working until pwm has been stopped.  
Other commands are possible while pwm is running.  
Returns frequency, if successful.  
Expected values:

  - slot: [0] to [3], depending on the initialized boards
  - pwmDev: Names displayed in help command or XMC1100 Bootkit IO numbers depending on the initialized boards, only direct drive pins supported yet
  - frequency: [64] (100Hz) to [30D40] (200kHz), [0] turns off pwm for selected pwmDev and activates normal io operation again
  - dutyCycle: [0] (ioDev off) to [64] (ioDev on)

- **spi(slot, spiDev, out) - spi write**

Sends an spi command with content out to device spiDev (normaly 0).

Returns the return value of the previous command, if successful (previous command can be the watchdog command, if activated).

Expected values:

- slot: [0] to [3], depending on the initialized boards, msc is only available for slot [3] on Engine-Management-Connection-PCB yet
- spiDev: [0]
- out: [0] to [FFFF] or [0] to [FFFFFFFF], depending on the datawith of the particular Eval-PCB

- **spis(slot, spiDev, out1, out2, ticks) - spi sequence**

Sends two spi commands with with a delay of ticks ms to device spiDev (normaly 0).

Returns the return value of the command before the second command, if successful (watchdog command can be sent between both commands, if activated).

Expected values:

- slot: [0] to [3], depending on the initialized boards, msc is only available for slot [3] on Engine-Management-Connection-PCB yet
- spiDev: [0]
- outx: [0] to [FFFF] or [0] to [FFFFFFFF], depending on the datawith of the particular Eval-PCB
- ticks: [1] to [FFFFFFFF]

- **spir(slot, spiDev, out, nop) - spi read**

Sends two spi commands in quick succession to device spiDev (normaly 0).

In contrast to other spi functions not interrupted by watchdog.

Returns the return value of first command (which is received while sending the second command).

Second command can either be a "no operation" value or another command whose answer is not needed.

Expected values:

- slot: [0] to [3], depending on the initialized boards, msc is only available for slot [3] on Engine-Management-Connection-PCB yet
- spiDev: [0]
- out: [0] to [FFFF] or [0] to [FFFFFFFF], depending on the datawith of the particular Eval-PCB
- nop: [0] to [FFFF] or [0] to [FFFFFFFF], depending on the datawith of the particular Eval-PCB

- **wd - watchdog(slot,wdDev,out,interval)**

Activates watchdog to send out every interval  $\mu$ s.

Other commands are possible while wd is running.

WD uses spi or msc bus depending on the initialized Eval-PCB.

When using msc bus out is ignored and only the previous data frame is repeated.

Returns interval, if successful.

Expected values:

- slot: [0] to [3], depending on the initialized boards, msc is only available for slot [3] on Engine-Management-Connection-PCB yet
- wdDev: [0]

#### Appendix

- out: [0] to [FFFF] or [0] to [FFFFFFFF], depending on the datawidth of the particular Eval-PCB
- interval: [0] and [A] (10 $\mu$ s) to [FFFFFF] (16.7s), [A] (10 $\mu$ s) will be set for lower values, [0] will turn watchdog off

**Appendix**

**Revision history**

**Major changes since the last revision**

<b>Page or Reference</b>	<b>Description of change</b>
Rev. 1.0	Initial release
Rev. 1.1	Section on Microcontroller Flashing was added.

#### Trademarks of Infineon Technologies AG

$\mu$ HVIC™,  $\mu$ IPM™,  $\mu$ PFC™, AU-ConvertIR™, AURIX™, C166™, CanPAK™, CIPOS™, CIPURSE™, CoolDP™, CoolGaN™, COOLiR™, CoolMOS™, CoolSET™, CoolSiC™, DAVE™, DI-POL™, DirectFET™, DrBlade™, EasyPIM™, EconoBRIDGE™, EconoDUAL™, EconoPACK™, EconoPIM™, EiceDRIVER™, eupec™, FCOS™, GaNpowIR™, HEXFET™, HITFET™, HybridPACK™, iMOTION™, IRAM™, ISOFACE™, IsoPACK™, LEDrivr™, LITIX™, MIPAQ™, ModSTACK™, my-d™, NovalithIC™, OPTIGA™, OptiMOS™, ORIGA™, PowIRaudio™, PowIRStage™, PrimePACK™, PrimeSTACK™, PROFET™, PRO-SIL™, RASIC™, REAL3™, SmartLEWIS™, SOLID FLASH™, SPOC™, StrongIRFET™, SupIRBuck™, TEMPFET™, TRENCHSTOP™, TriCore™, UHVIC™, XHP™, XMC™

Trademarks updated November 2015

#### Other Trademarks

All referenced product or service names and trademarks are the property of their respective owners.

#### Edition Date

##### Published by

**Infineon Technologies AG**

**81726 München, Germany**

**© 2019 Infineon Technologies AG.**

**All Rights Reserved.**

**Do you have a question about this document?**

**Email: [erratum@infineon.com](mailto:erratum@infineon.com)**

#### Document reference

**v0.1**

#### IMPORTANT NOTICE

The information given in this document shall in no event be regarded as a guarantee of conditions or characteristics ("Beschaffheitsgarantie").

With respect to any examples, hints or any typical values stated herein and/or any information regarding the application of the product, Infineon Technologies hereby disclaims any and all warranties and liabilities of any kind, including without limitation warranties of non-infringement of intellectual property rights of any third party.

In addition, any information given in this document is subject to customer's compliance with its obligations stated in this document and any applicable legal requirements, norms and standards concerning customer's products and any use of the product of Infineon Technologies in customer's applications.

The data contained in this document is exclusively intended for technically trained staff. It is the responsibility of customer's technical departments to evaluate the suitability of the product for the intended application and the completeness of the product information given in this document with respect to such application.

For further information on the product, technology delivery terms and conditions and prices please contact your nearest Infineon Technologies office ([www.infineon.com](http://www.infineon.com)).

#### WARNINGS

Due to technical requirements products may contain dangerous substances. For information on the types in question please contact your nearest Infineon Technologies office.

Except as otherwise explicitly approved by Infineon Technologies in a written document signed by authorized representatives of Infineon Technologies, Infineon Technologies' products may not be used in any applications where a failure of the product or any consequences of the use thereof car reasonably be expected to result in personal injury.



## Стандарт Электрон Связь

Мы молодая и активно развивающаяся компания в области поставок электронных компонентов. Мы поставляем электронные компоненты отечественного и импортного производства напрямую от производителей и с крупнейших складов мира.

Благодаря сотрудничеству с мировыми поставщиками мы осуществляем комплексные и плановые поставки широчайшего спектра электронных компонентов.

Собственная эффективная логистика и склад в обеспечивает надежную поставку продукции в точно указанные сроки по всей России.

Мы осуществляем техническую поддержку нашим клиентам и предпродажную проверку качества продукции. На все поставляемые продукты мы предоставляем гарантию .

Осуществляем поставки продукции под контролем ВП МО РФ на предприятия военно-промышленного комплекса России , а также работаем в рамках 275 ФЗ с открытием отдельных счетов в уполномоченном банке. Система менеджмента качества компании соответствует требованиям ГОСТ ISO 9001.

Минимальные сроки поставки, гибкие цены, неограниченный ассортимент и индивидуальный подход к клиентам являются основой для выстраивания долгосрочного и эффективного сотрудничества с предприятиями радиоэлектронной промышленности, предприятиями ВПК и научно-исследовательскими институтами России.

С нами вы становитесь еще успешнее!

### Наши контакты:

**Телефон:** +7 812 627 14 35

**Электронная почта:** [sales@st-electron.ru](mailto:sales@st-electron.ru)

**Адрес:** 198099, Санкт-Петербург,  
Промышленная ул, дом № 19, литера Н,  
помещение 100-Н Офис 331