

DATA SHEET

SKY13298-360LF: GaAs SP2T Switch for Ultra Wideband (UWB) 3–8 GHz

Features

- Positive voltage control (0/1.8 V to 0/3.3 V)
- High isolation 25 dB for BG1, 25 dB for BG3
- Low loss 0.7 dB typical for BG1, 0.9 dB for BG3
- Lead (Pb)-free and RoHS-compliant

Description

The SKY13298-360LF is a pHEMT GaAs FET IC switch packaged in an 2 x 2 mm, 8-lead exposed pad plastic package for low-cost commercial applications. The use of the V_{BIAS} line enables the part to be used with low control bias voltages down to 1.8 V. This switch is ideal for Ultra Wide Band (UWB) applications covering BG1 and BG3. For 3.3 V control, the V_{BIAS} is not required and is left open circuit on the board.

NEW Skyworks offers lead (Pb)-free, RoHS (Restriction of Hazardous Substances)-compliant packaging.



Functional Block Diagram

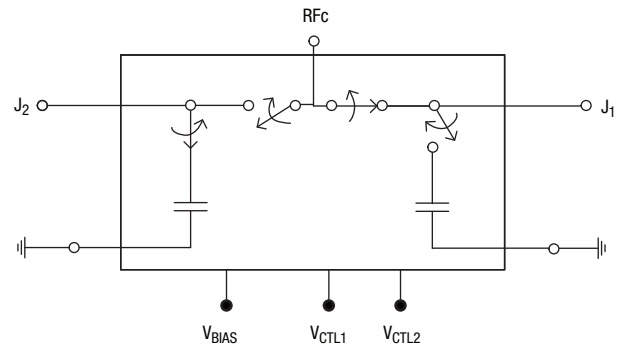

Electrical Specifications

$V_{BIAS} = 1.8\text{ V}$, $V_{CTL} = 0\text{ V}/1.8\text{ V}$, $T = 25\text{ }^\circ\text{C}$, $P_{INPUT} = 0\text{ dBm}$, $Z_0 = 50\text{ }\Omega$, unless otherwise noted

Parameter	Frequency	Min.	Typ.	Max.	Unit
Insertion Loss	3.168–4.752 GHz		0.7	0.9	dB
	6.336–7.920 GHz		0.9	1.0	dB
Isolation	3.168–4.752 GHz	22	25		dB
	6.336–7.920 GHz	19	22		dB
Return loss (Insertion loss state)	3.168–4.752 GHz		25		dB
	6.336–7.920 GHz		12		dB

Operating Characteristics

V_{BIAS} = 1.8 V, V_{CTL} = 0 V/1.8 V, T = 25 °C, P_{INPUT} = 0 dBm, Z₀ = 50 Ω, unless otherwise noted

Parameter	Condition	Frequency	Min.	Typ.	Max.	Unit
Switching characteristics Rise/fall time On/off time	10/90% or 90/10% RF 50% V _{CTL} to 90/10% RF			20 20		ns ns
Input power for 1 dB compression	V _{BIAS} = 1.8 V, V _{CTL} = 0 V/1.8 V V _{BIAS} = 1.8 V, V _{CTL} = 0 V/1.8 V V _{BIAS} = open circuit, V _{CTL} = 0 V/3.3 V V _{BIAS} = open circuit, V _{CTL} = 0 V/3.3 V	3.168–4.752 GHz 6.336–7.920 GHz 3.168–4.752 GHz 6.336–7.920 GHz		18 16 26 24		dBm dBm dBm dBm
Intermodulation intercept point (IP3)	For two tone input power 5 dBm/tone 1 MHz spacing, V _{BIAS} = 1.8 V, V _{CTL} = 0 V/1.8 V V _{BIAS} = 0 V, V _{CTL} = 0 V/3.3 V	3.168–4.752 GHz 6.336–7.920 GHz 3.168–4.752 GHz 6.336–7.920 GHz		39 34 47 42		dBm dBm dBm dBm
Control voltages	V _{CTL} LOW V _{CTL} HIGH = V _{BIAS}		0 1.8		0.2 3.3	V V
Supply voltage	V _{BIAS}		1.8		3.3	V
Supply currents	V _{BIAS} = 1.8 to 3.3 V V _{CTL} LOW, V _{CTL} HIGH			5 5		μA μA

Truth Table

V _{BIAS}	V _{CTL1}	V _{CTL2}	RFc-J ₁	RFc-J ₂
1	1	0	Insertion loss	Isolation
1	0	1	Isolation	Insertion loss

"1" = 1.8 to 3.3 V.

"0" = 0 V.

For "1" > 3 V, V_{BIAS} is not necessary and may be left open ckt.

Any state other than described in the truth table will put the switch in an undefined state.

Absolute Maximum Ratings

Characteristic	Value
V _{BIAS} voltage range	1.8 ≤ V _{BIAS} ≤ 5 V
RF input power @ 3 V	27 dBm
Operating temperature	-40 °C to +85 °C
Storage temperature	-65 °C to +150 °C

Performance is guaranteed only under the conditions listed in the specifications table and is not guaranteed under the full range(s) described by the Absolute Maximum specifications. Exceeding any of the absolute maximum/minimum specifications may result in permanent damage to the device and will void the warranty.

CAUTION: *Although this device is designed to be as robust as possible, ESD (Electrostatic Discharge) can damage this device. This device must be protected at all times from ESD. Static charges may easily produce potentials of several kilovolts on the human body or equipment, which can discharge without detection. Industry-standard ESD precautions must be employed at all times.*

Typical Performance Data

$V_{BIAS} = 1.8\text{ V}$, $V_{CTL} = 0\text{ V}/1.8\text{ V}$, and $V_{BIAS} = \text{Open Circuit}$, $V_{CTL} = 0\text{ V}/3.3\text{ V}$, $T = 25\text{ }^\circ\text{C}$, $P_{INPUT} = 0\text{ dBm}$, $Z_0 = 50\text{ }\Omega$, $C_{BLK} = 15\text{ pF}$, $C_{BP} = 33\text{ pF}$ unless otherwise noted

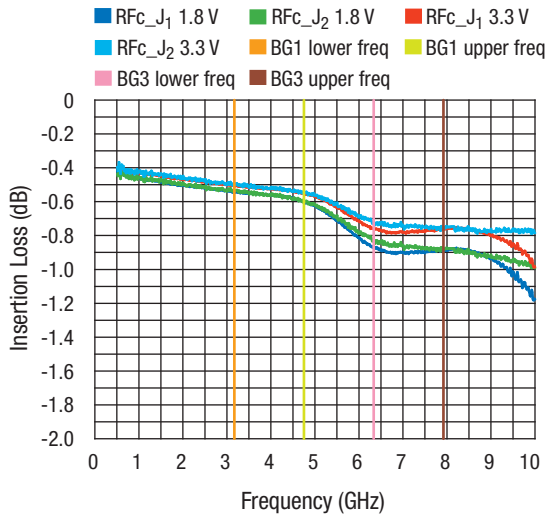

Typical Insertion Loss

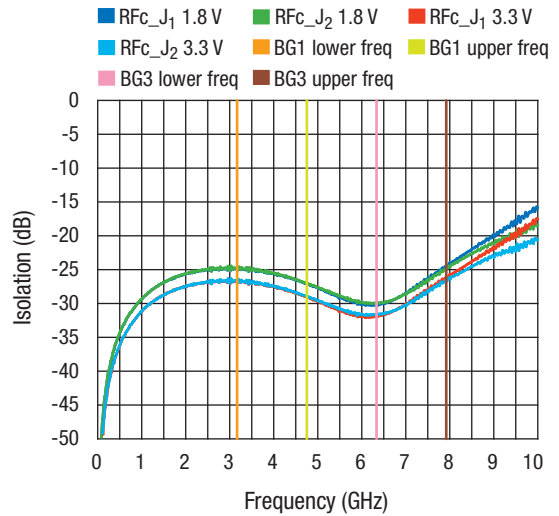

Typical Isolation

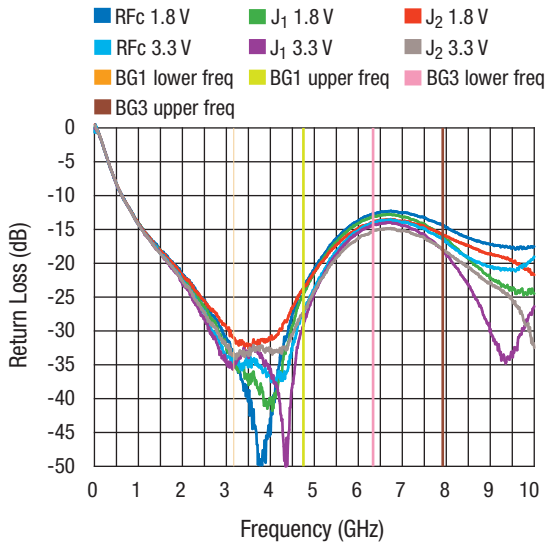

Return Loss (Ins. Loss state)

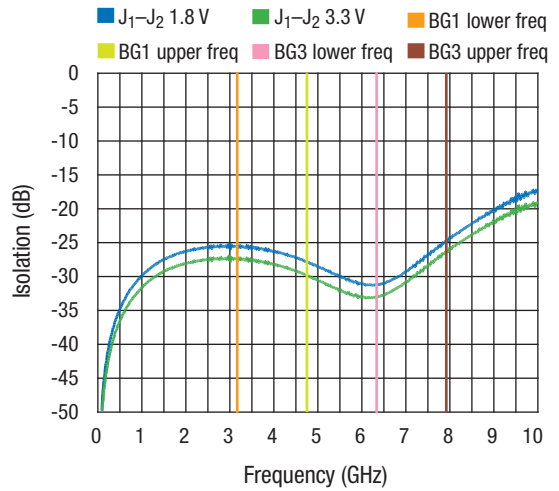

Typical J1-J2 Isolation

Pin Out (Top View)

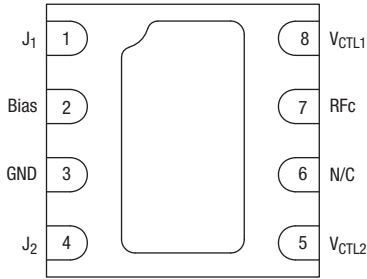

DC blocks are required on RFc, J1, J2.
 C_{BLK} = 15 pF for UWB band operation.

Evaluation Board

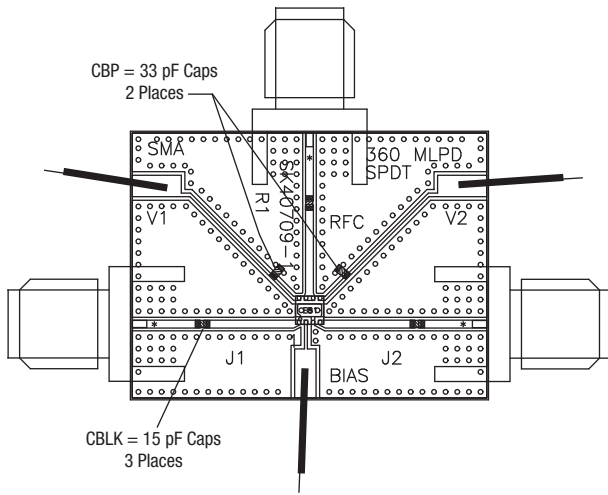

QFN 8L 2 x 2 mm Package

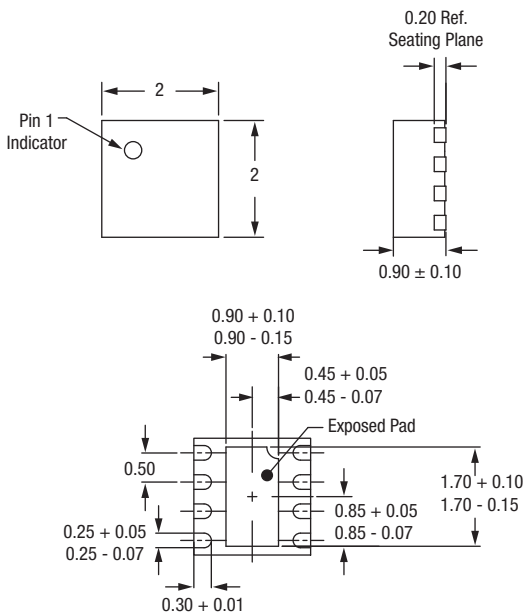

Pin Descriptions

Pin Number	Pin Name	Description
1	J ₁	RF port
2	Bias	V _{BIAS}
3	Gnd	Gnd
4	J ₂	RF port
5	V _{CTL2}	DC control voltage
6	N/C	No connect
7	RFc	RF common port
8	V _{CTL1}	DC control voltage
Exposed paddle	Paddle	Must be connected to RF ground

Suggested Land Pattern

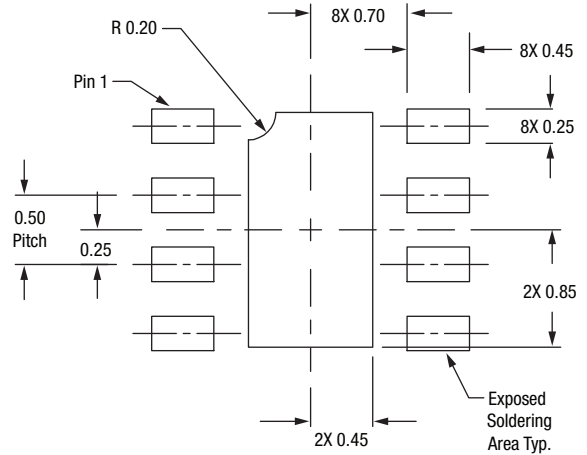

Recommended Solder Reflow Profiles

Refer to the [“Recommended Solder Reflow Profile”](#) Application Note.

Tape and Reel Information

Refer to the [“Discrete Devices and IC Switch/Attenuators Tape and Reel Package Orientation”](#) Application Note.

Copyright © 2002, 2003, 2004, 2005, 2006, 2007, 2008, Skyworks Solutions, Inc. All Rights Reserved.

Information in this document is provided in connection with Skyworks Solutions, Inc. ("Skyworks") products or services. These materials, including the information contained herein, are provided by Skyworks as a service to its customers and may be used for informational purposes only by the customer. Skyworks assumes no responsibility for errors or omissions in these materials or the information contained herein. Skyworks may change its documentation, products, services, specifications or product descriptions at any time, without notice. Skyworks makes no commitment to update the materials or information and shall have no responsibility whatsoever for conflicts, incompatibilities, or other difficulties arising from any future changes.

No license, whether express, implied, by estoppel or otherwise, is granted to any intellectual property rights by this document. Skyworks assumes no liability for any materials, products or information provided hereunder, including the sale, distribution, reproduction or use of Skyworks products, information or materials, except as may be provided in Skyworks Terms and Conditions of Sale.

THE MATERIALS, PRODUCTS AND INFORMATION ARE PROVIDED "AS IS" WITHOUT WARRANTY OF ANY KIND, WHETHER EXPRESS, IMPLIED, STATUTORY, OR OTHERWISE, INCLUDING FITNESS FOR A PARTICULAR PURPOSE OR USE, MERCHANTABILITY, PERFORMANCE, QUALITY OR NON-INFRINGEMENT OF ANY INTELLECTUAL PROPERTY RIGHT; ALL SUCH WARRANTIES ARE HEREBY EXPRESSLY DISCLAIMED. SKYWORKS DOES NOT WARRANT THE ACCURACY OR COMPLETENESS OF THE INFORMATION, TEXT, GRAPHICS OR OTHER ITEMS CONTAINED WITHIN THESE MATERIALS. SKYWORKS SHALL NOT BE LIABLE FOR ANY DAMAGES, INCLUDING BUT NOT LIMITED TO ANY SPECIAL, INDIRECT, INCIDENTAL, STATUTORY, OR CONSEQUENTIAL DAMAGES, INCLUDING WITHOUT LIMITATION, LOST REVENUES OR LOST PROFITS THAT MAY RESULT FROM THE USE OF THE MATERIALS OR INFORMATION, WHETHER OR NOT THE RECIPIENT OF MATERIALS HAS BEEN ADVISED OF THE POSSIBILITY OF SUCH DAMAGE.

Skyworks products are not intended for use in medical, lifesaving or life-sustaining applications, or other equipment in which the failure of the Skyworks products could lead to personal injury, death, physical or environmental damage. Skyworks customers using or selling Skyworks products for use in such applications do so at their own risk and agree to fully indemnify Skyworks for any damages resulting from such improper use or sale.

Customers are responsible for their products and applications using Skyworks products, which may deviate from published specifications as a result of design defects, errors, or operation of products outside of published parameters or design specifications. Customers should include design and operating safeguards to minimize these and other risks. Skyworks assumes no liability for applications assistance, customer product design, or damage to any equipment resulting from the use of Skyworks products outside of stated published specifications or parameters.

Skyworks, the Skyworks symbol, and "Breakthrough Simplicity" are trademarks or registered trademarks of Skyworks Solutions, Inc., in the United States and other countries. Third-party brands and names are for identification purposes only, and are the property of their respective owners. Additional information, including relevant terms and conditions, posted at www.skyworksinc.com, are incorporated by reference.



Стандарт Электрон Связь

Мы молодая и активно развивающаяся компания в области поставок электронных компонентов. Мы поставляем электронные компоненты отечественного и импортного производства напрямую от производителей и с крупнейших складов мира.

Благодаря сотрудничеству с мировыми поставщиками мы осуществляем комплексные и плановые поставки широчайшего спектра электронных компонентов.

Собственная эффективная логистика и склад в обеспечивает надежную поставку продукции в точно указанные сроки по всей России.

Мы осуществляем техническую поддержку нашим клиентам и предпродажную проверку качества продукции. На все поставляемые продукты мы предоставляем гарантию .

Осуществляем поставки продукции под контролем ВП МО РФ на предприятия военно-промышленного комплекса России , а также работаем в рамках 275 ФЗ с открытием отдельных счетов в уполномоченном банке. Система менеджмента качества компании соответствует требованиям ГОСТ ISO 9001.

Минимальные сроки поставки, гибкие цены, неограниченный ассортимент и индивидуальный подход к клиентам являются основой для выстраивания долгосрочного и эффективного сотрудничества с предприятиями радиоэлектронной промышленности, предприятиями ВПК и научно-исследовательскими институтами России.

С нами вы становитесь еще успешнее!

Наши контакты:

Телефон: +7 812 627 14 35

Электронная почта: sales@st-electron.ru

Адрес: 198099, Санкт-Петербург,
Промышленная ул, дом № 19, литера Н,
помещение 100-Н Офис 331