

AVX MOBO® Spring Contact Interconnect Solutions

MOBO® Connectors
www.avx.com



Version 12.3

AVX INTERCONNECT
A KYOCERA GROUP COMPANY

Table of Contents



BATTERY CONNECTORS, SERIES 9155	2-16
Battery; Standard Size.....	2
Battery; Reduced Size.....	4
Battery; Ultra Low Profile	7
Battery; Solderless	9
Battery; 3.0mm Right Angle.....	10
Battery; 2.5mm Right Angle.....	13
SIM CARD CONNECTORS SERIES 9162	17-24
Slide-In SIM.....	17
SIM Block.....	19
SIM Connector with Locking Latch	21
SIM/microSD Micro Combination	23
BOARD TO BOARD, SERIES 9158	25-32
SOLO Stacker, 9158 Series	25
Staggered SOLO Stacker, 9188 Series	27
Ultra Low Profile Stacker, 9258 Series	31
I/O CONNECTORS	33-45
Standard I/O, 15 Position, 9157 Series	33
Standard I/O, 19 Position, 9157 Series	37
Reduced Size I/O, 9257 Series.....	39
Mini I/O, 9257 Series	42

NOTICE: Specifications are subject to change without notice. Contact your nearest AVX Sales Office for the latest specifications. All statements, information and data given herein are believed to be accurate and reliable, but are presented without guarantee, warranty, or responsibility of any kind, expressed or implied. Statements or suggestions concerning possible use of our products are made without representation or warranty that any such use is free of patent infringement and are not recommendations to infringe any patent. The user should not assume that all safety measures are indicated or that other measures may not be required. Specifications are typical and may not apply to all applications.



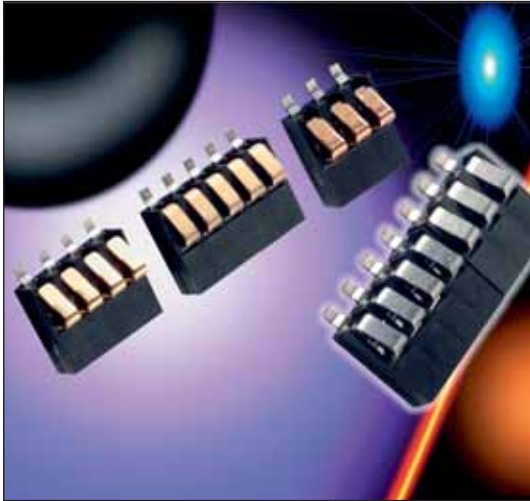

GENERAL DESCRIPTION

The standard battery connector is specifically designed for mobile equipment. The connectors are available in 3, 4 and 5 contact positions all on a 2.50mm pitch. The insulator height provides a 3mm spacing, with various contact nose heights from 1.20mm to 2.60mm, to provide spacing options to the end user.

All contacts are stamped and are rated to 3A, with Gold plating. Parts are supplied in tape and reel for automatic pick and place. Optional retaining brackets are available to provide greater strength when connected to the PCB. Whatever your requirements, the 9155 series Battery Connector can also be customized to suit your applications.

APPLICATIONS

- Mobile Phones
- PDA
- Medical
- PMR
- Industrial

KEY FEATURES AND BENEFITS

- Suitable for 5000 mechanical cycles.
- Variety of contact heights offered to suit different mechanical designs.
- Connectors can be end to end stackable.
- RoHS Compliant available.



3 Way Battery Connector

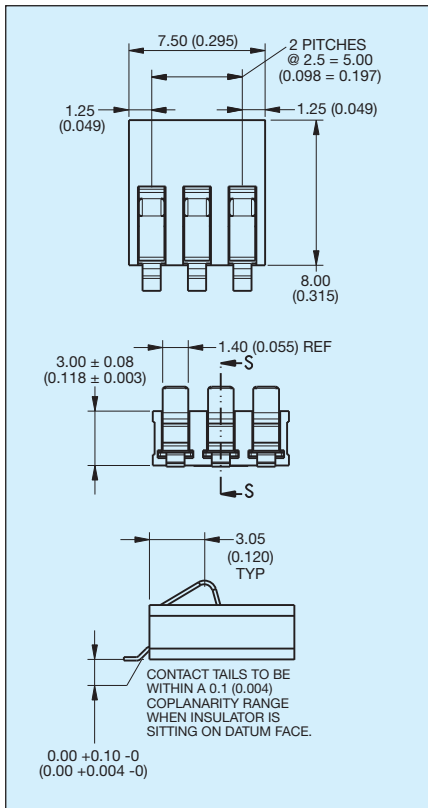

4 Way Battery Connector

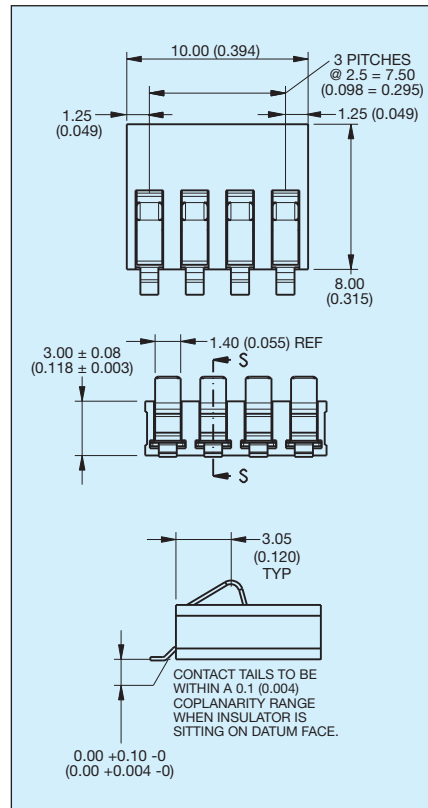

5 Way Battery Connector

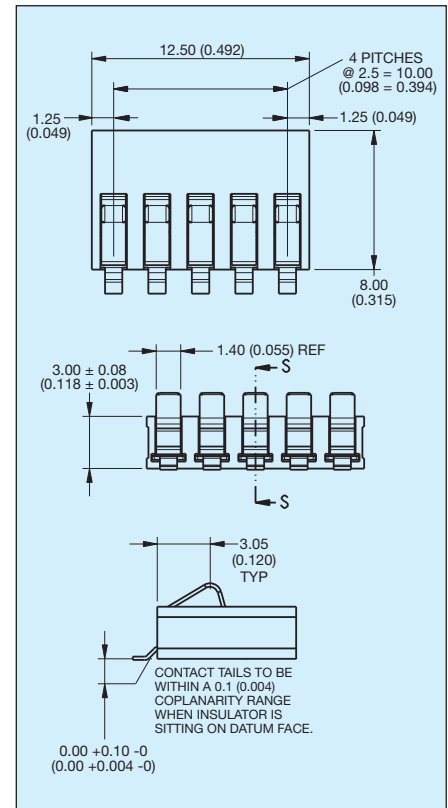

3 Way PCB Board Layout

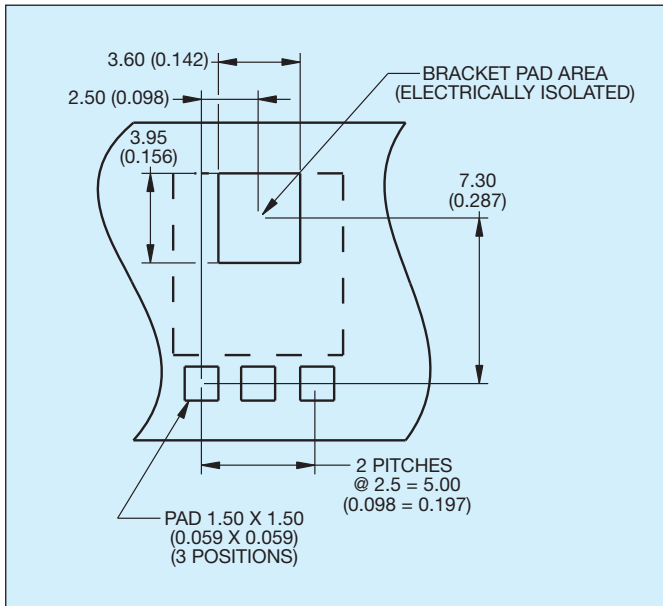

4 Way PCB Board Layout

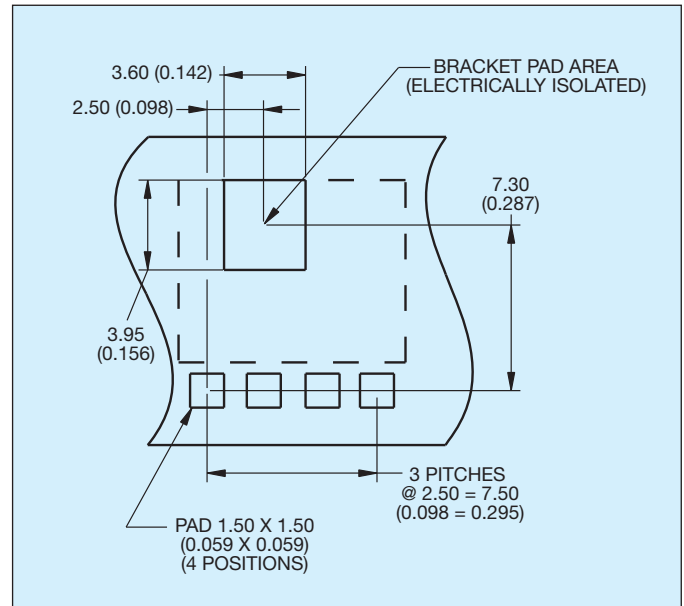

5 Way PCB Board Layout

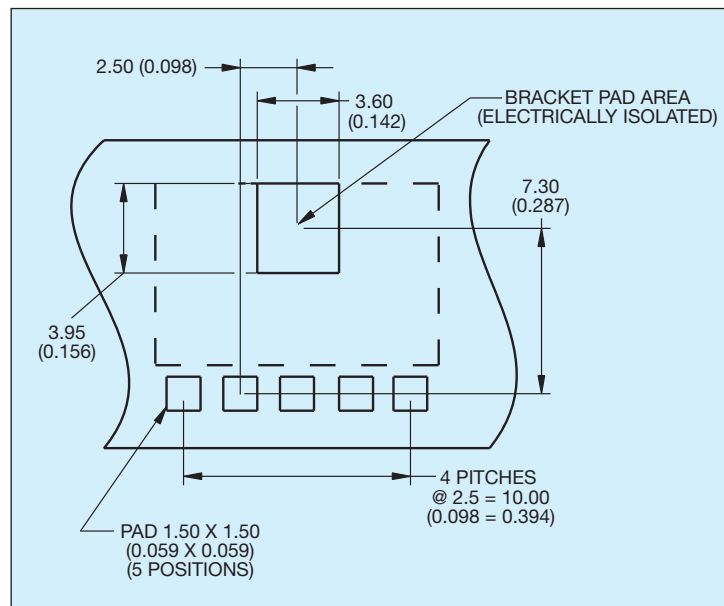

HOW TO ORDER

00	9155	003	00	1	01	6
Prefix	Series	No of Ways	Standard Battery Connector	Contact Height	Bracket	Plating Option
00 = Standard 58 = Special		3 = 003 4 = 004 5 = 005	00 = Standard Force	1 = 1.20 (0.047) / 1.50 (0.059) 2 = 1.80 (0.071) / 2.10 (0.083) 3 = 2.30 (0.091) / 2.60 (0.102)	01 = With Bracket	6 = 0.4µm Selective Gold, Pure Tin Tail 8 = 0.8µm Selective Gold, Pure Tin Tail

9155 Size Reduced Battery Connector



GENERAL DESCRIPTION

The newest product in AVX's Interconnect family of battery connectors saves 50% in volume over the initial 9155 series compression connectors as illustrated in the photograph. These connectors are rated at a full 3 amps per contact on 2.5mm centers. Sizes range from 2 positions through 5 positions and are end to end stackable.

APPLICATIONS

- Cellular Phones
- Handheld Devices
- Industrial Modules
- Medical Electronics

KEY FEATURES AND BENEFITS

- 2.4mm insulator height
- 3 amps/contact
- Large SMT mounting area for positive mechanical attachment
- 5k mating cycles
- End-to-end stackable



HOW TO ORDER

00
Prefix

9155
Series

003
No. of Ways

201
Reduced Size Battery Connector

XXX
Plating Option

Code	No. of Ways	Reel Qty	Packing Qty
002	2	2000	2000
003	3	2000	2000
004	4	2000	2000
005	5	2000	2000

Code	Description
201	Reduced Size Battery Connector

Code	Description
006	0.4µm Selective Gold, Pure Tin Tail
008	0.8µm Selective Gold, Pure Tin Tail

9155 Size Reduced Battery Connector

2 Way Reduced Battery Connector

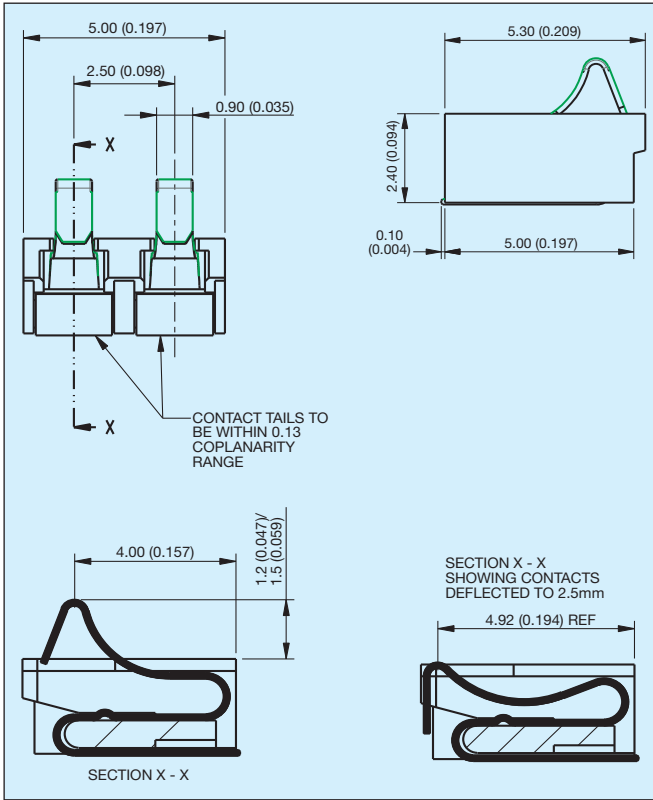

3 Way Reduced Battery Connector

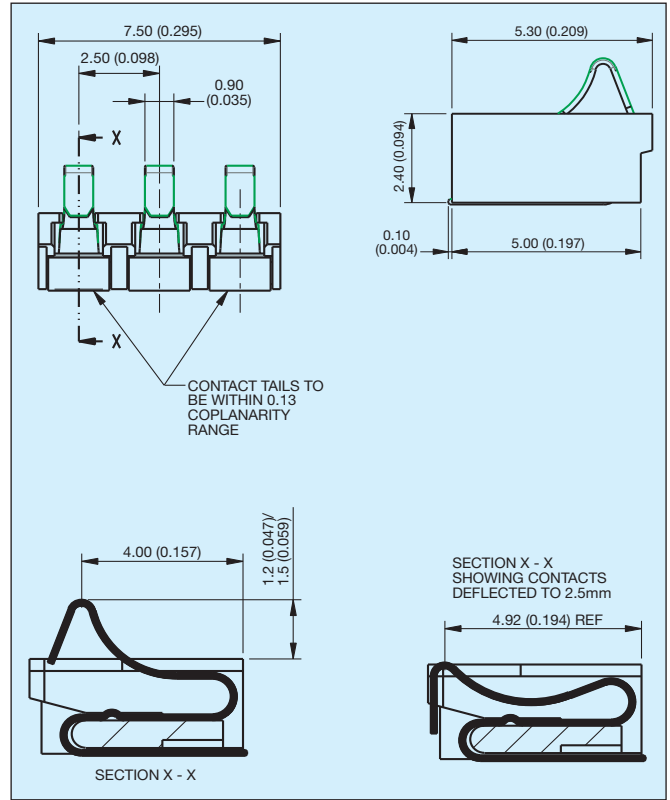

4 Way Reduced Battery Connector

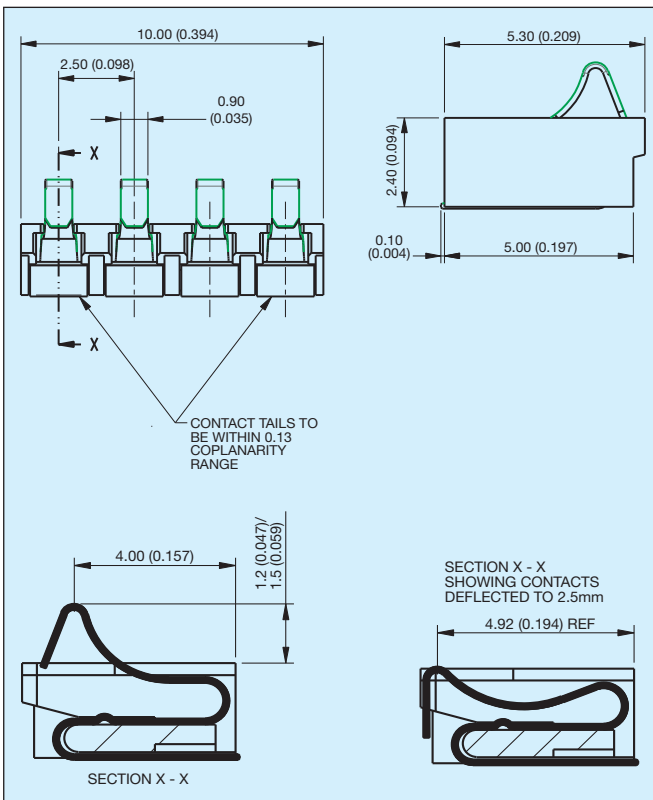

5 Way Reduced Battery Connector

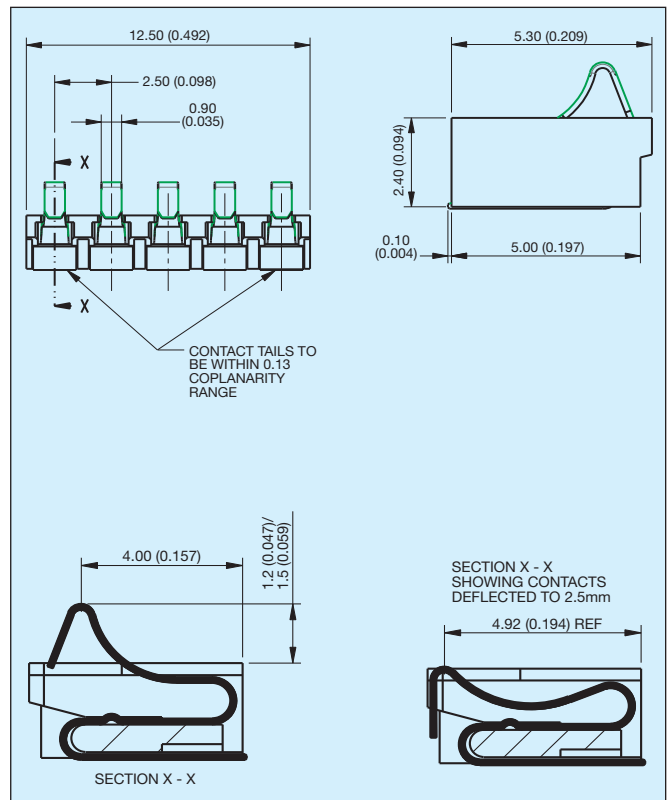

9155 Size Reduced Battery Connector

2 Way Reduced Battery Connector PCB Layout

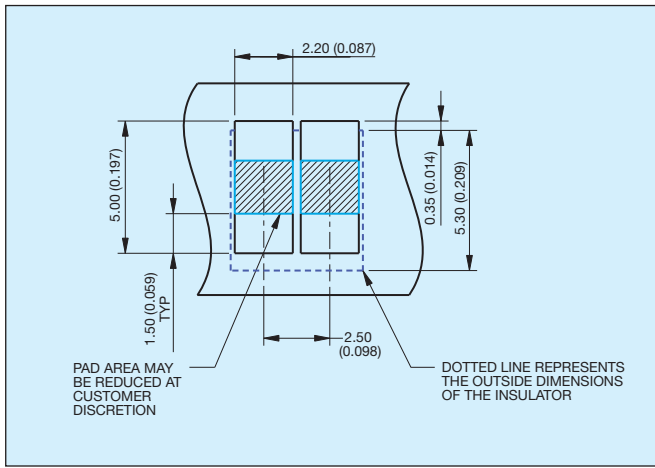

3 Way Reduced Battery Connector PCB Layout

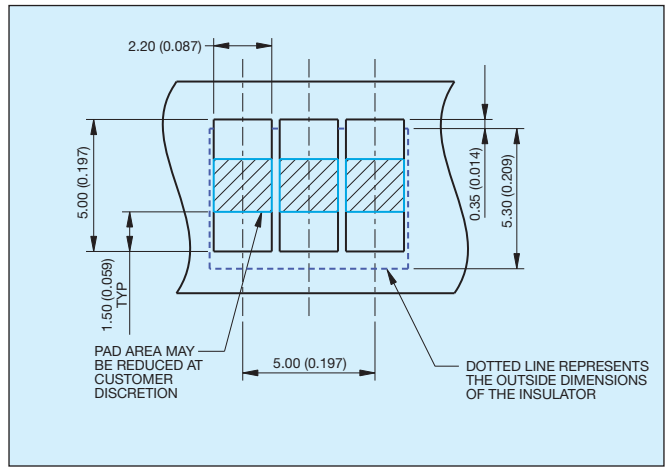

4 Way Reduced Battery Connector PCB Layout

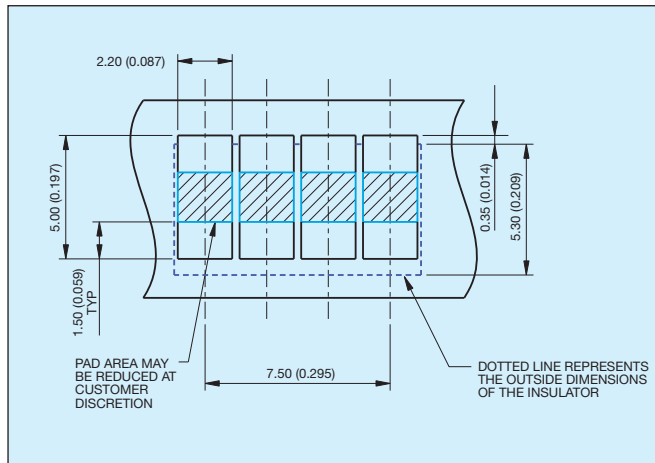

5 Way Reduced Battery Connector PCB Layout

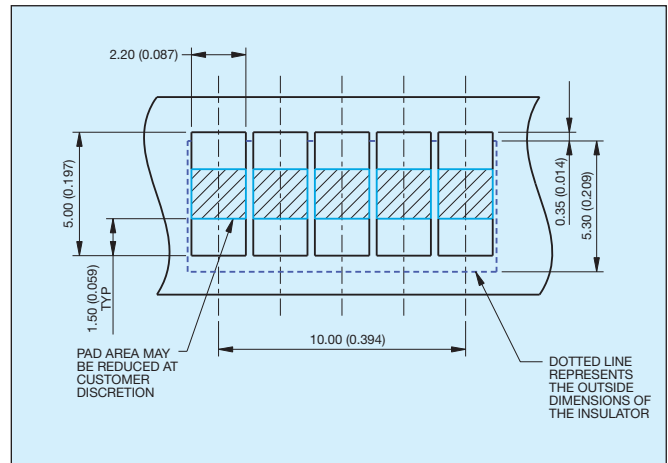

9155 Ultra-Low Profile Battery



GENERAL DESCRIPTION

The AVX Interconnect group has released a new ultra-low profile 3 amp per contact connector for battery pack or slide-in module applications. The compressed "Z" axis height of 1.3mm leads the industry from a profile standpoint. The initial product is in a 2 & 3 position configuration with other sizes expected to follow. The connector has an integral end block to act as a mechanical stop.

APPLICATIONS

- Cellular Phones
- Handheld Devices
- Industrial Modules
- Medical Electronics

KEY FEATURES AND BENEFITS

- Ultra-Low Profile
- 3 amps/contact
- Integral End Stop
- 5k mating cycles



HOW TO ORDER

00

Prefix

9155

Series

003

No. of Ways

Code	No. of Ways	Qty. Per Reel
002	2	1500
003	3	1200

101

Low Profile Battery Connector

Code	Description	Operating Height
101	Low Profile Battery Connector	1.30 (0.051)

XXX

Plating Option

Code	Description
006	0.4µm Selective Gold, Pure Tin Tail
008	0.8µm Selective Gold, Pure Tin Tail

2 Way Low Profile Battery Connector

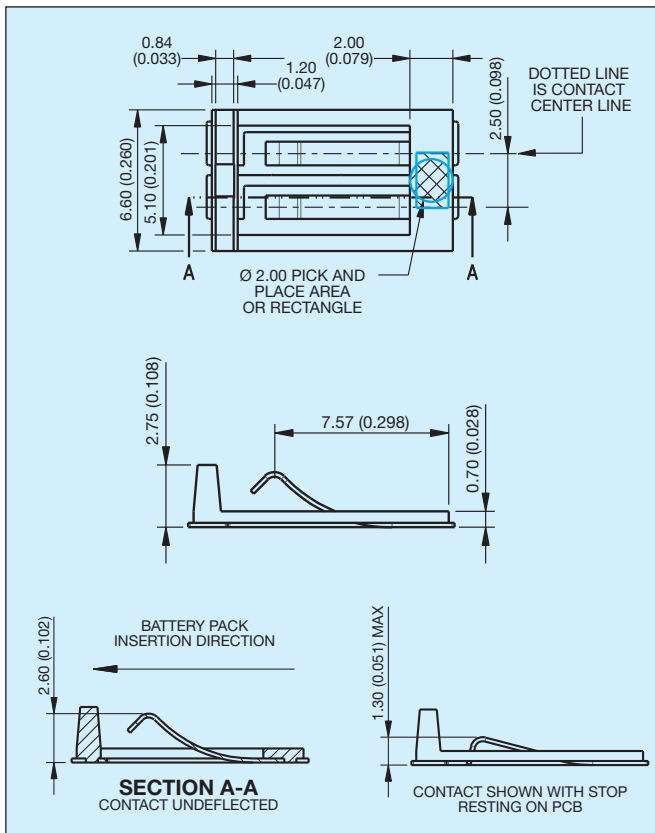

3 Way Low Profile Battery Connector

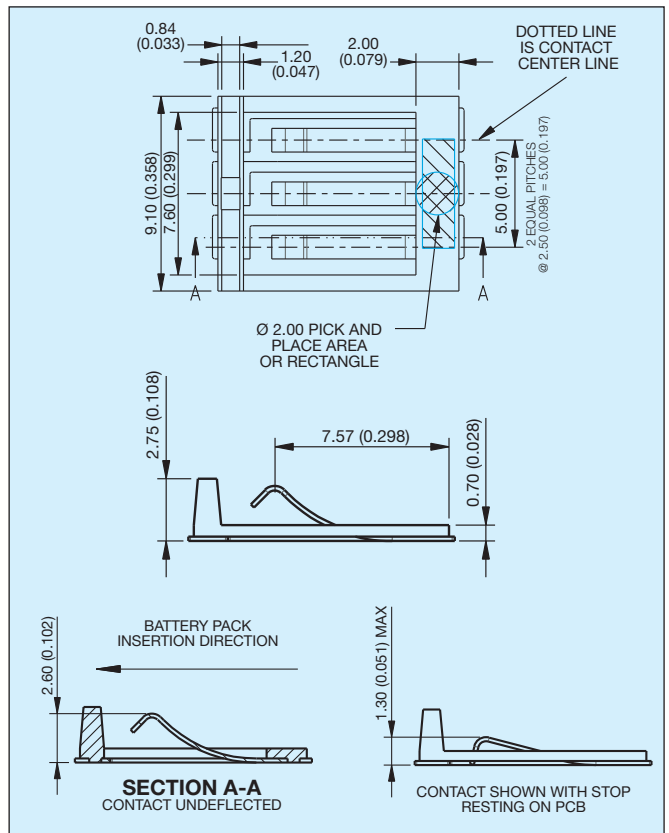

2 Way Low Profile Battery Connector PCB Layout

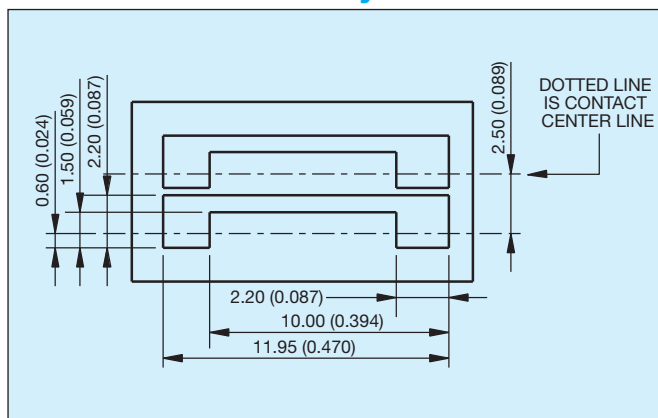

3 Way Low Profile Battery Connector PCB Layout

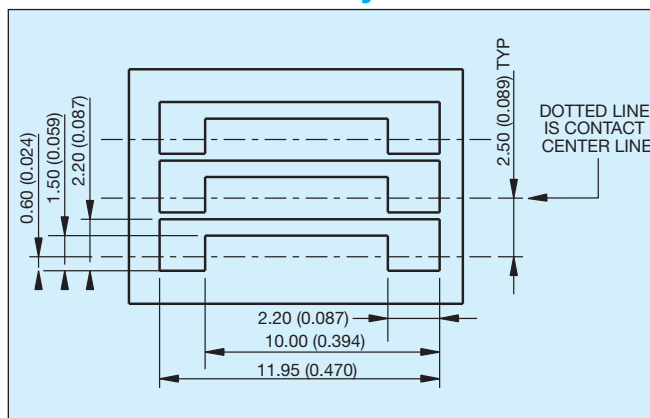

9155 MOBO[®] Solderless Battery Connectors



GENERAL DESCRIPTION

As an addition to our range of Battery connectors we have added a solderless termination option. This option has the termination area gold plated and the contact form is compression to the PCB and to the Battery which is used in the end equipment.

Rated at 3 Amps and 5,000 operations (the same as the SMT version). These battery connectors compliment the existing standard range of RoHS compliant components giving the designer an added option of the solderless termination.

When these connectors are held in place by the casing of the end equipment, the connection to the PCB is achieved by compressing the connector contacts against the PCB and against the actual battery. It is the housing which maintains the connection.

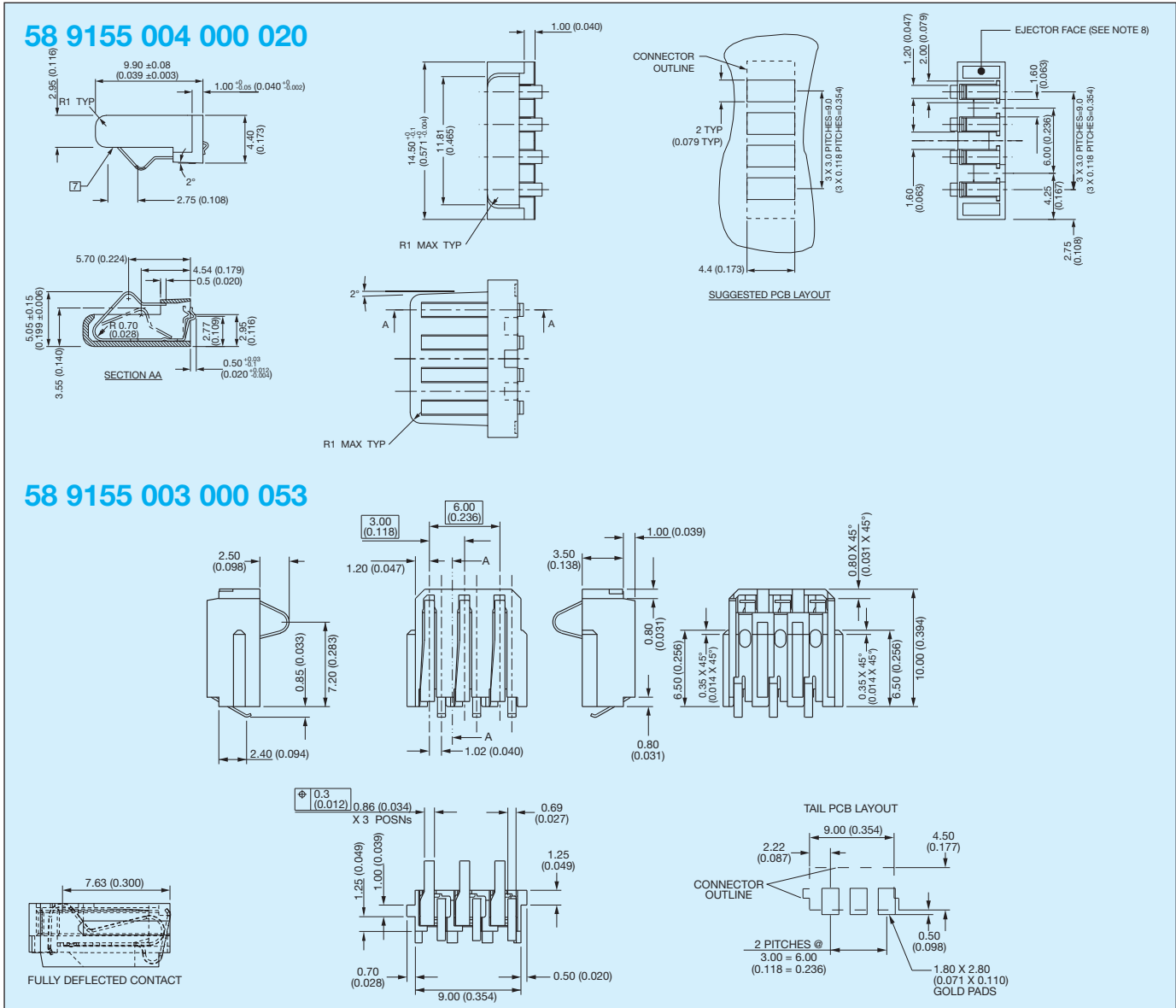

9155 MOBO[®] 3.0mm Pitch Right Angle Battery Connectors



GENERAL DESCRIPTION

A further addition to the battery connector range offered by AVX is a 90 degree version. On a 3mm pitch, offered in 2 to 5 contact positions and rated as with all of the battery range at 3 amps. The connector's design is small and compact to minimize its profile yet stable while having a contact point 4.61mm above the PCB.

The stability comes from the addition of extra SMT anchor brackets that are in between the SMT contact pads and both at the front of the connector and within the row of the contact SMT pads.

As with the other 9155 series of battery connectors offered by AVX the 90 degree version is rated at 3 amps and 5000 mating cycles, RoHS compliant and using high temperature plastic enables the connectors to be processed at up to 260°C.

APPLICATIONS

- Mobile phones
- Digital music players
- Hand held terminals
- Data terminals or any other small portable device

FEATURES AND BENEFITS

- Simple designed spring contact
- End to end stackable for larger pin counts
- Additional contact anchor brackets to added stability on the PCB
- Robust to shock and vibration
- Selectively plated contact area



HOW TO ORDER

00	9155	002	301	XXX																				
Prefix	Series	No. of Ways	Right Angle Battery Connector	Plating Option																				
		<table border="1"> <thead> <tr> <th>Code</th> <th>No. of Ways</th> </tr> </thead> <tbody> <tr> <td>002</td> <td>2</td> </tr> <tr> <td>003</td> <td>3</td> </tr> <tr> <td>004</td> <td>4</td> </tr> <tr> <td>005</td> <td>5</td> </tr> </tbody> </table>	Code	No. of Ways	002	2	003	3	004	4	005	5	<table border="1"> <thead> <tr> <th>Code</th> <th>Description</th> </tr> </thead> <tbody> <tr> <td>301</td> <td>Right Angle 3.00mm Battery Connector</td> </tr> </tbody> </table>	Code	Description	301	Right Angle 3.00mm Battery Connector	<table border="1"> <thead> <tr> <th>Code</th> <th>Description</th> </tr> </thead> <tbody> <tr> <td>006</td> <td>0.4µm Selective Gold, Pure Tin Tail</td> </tr> <tr> <td>008</td> <td>0.8µm Selective Gold, Pure Tin Tail</td> </tr> </tbody> </table>	Code	Description	006	0.4µm Selective Gold, Pure Tin Tail	008	0.8µm Selective Gold, Pure Tin Tail
Code	No. of Ways																							
002	2																							
003	3																							
004	4																							
005	5																							
Code	Description																							
301	Right Angle 3.00mm Battery Connector																							
Code	Description																							
006	0.4µm Selective Gold, Pure Tin Tail																							
008	0.8µm Selective Gold, Pure Tin Tail																							

9155 MOBO[®] 3.0mm Pitch Right Angle Battery Connectors



2 Way Right Angle Battery Connector

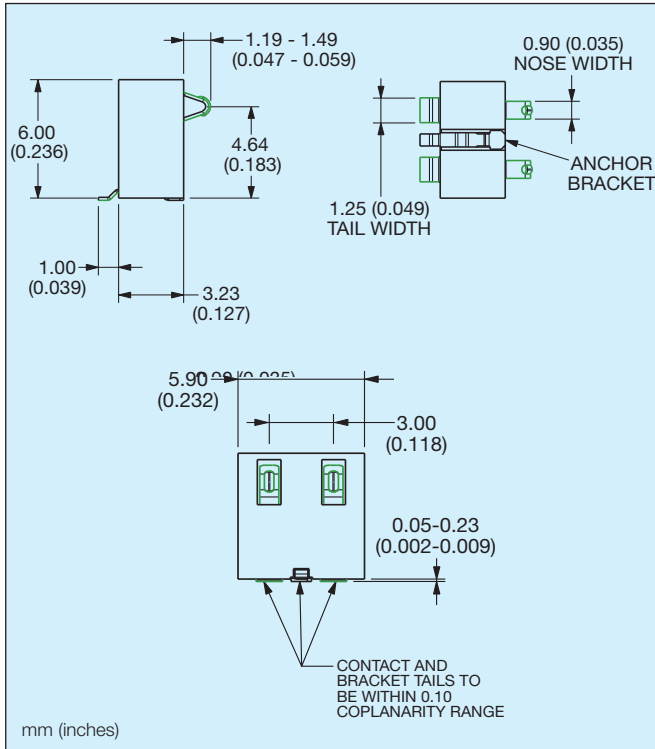

3 Way Right Angle Battery Connector

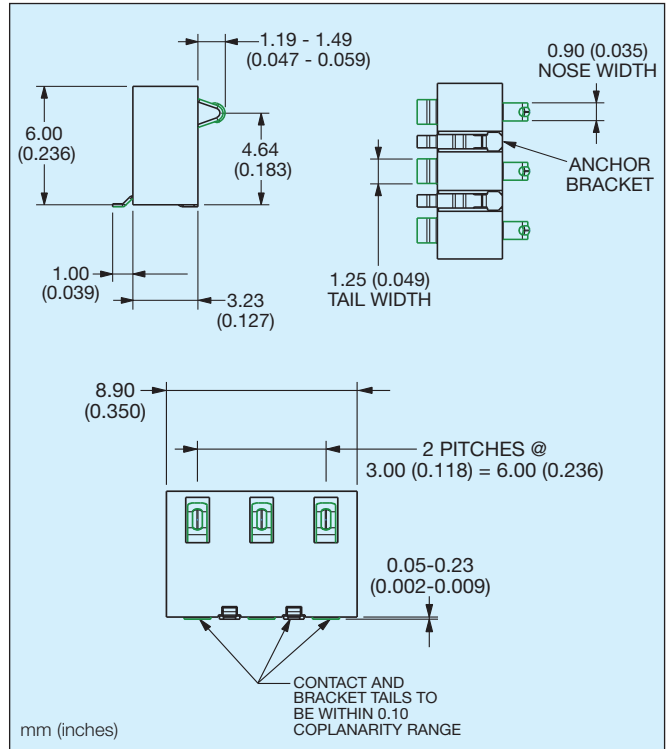

4 Way Right Angle Battery Connector

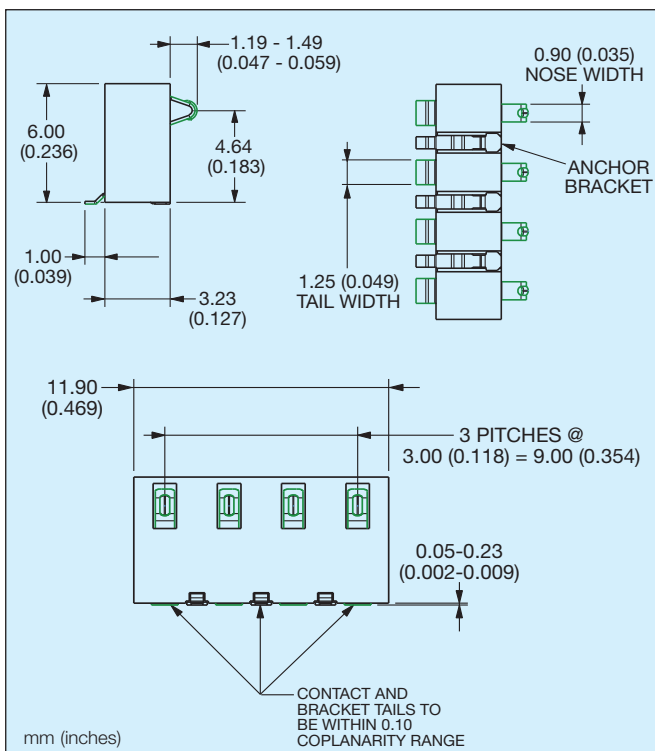

5 Way Right Angle Battery Connector

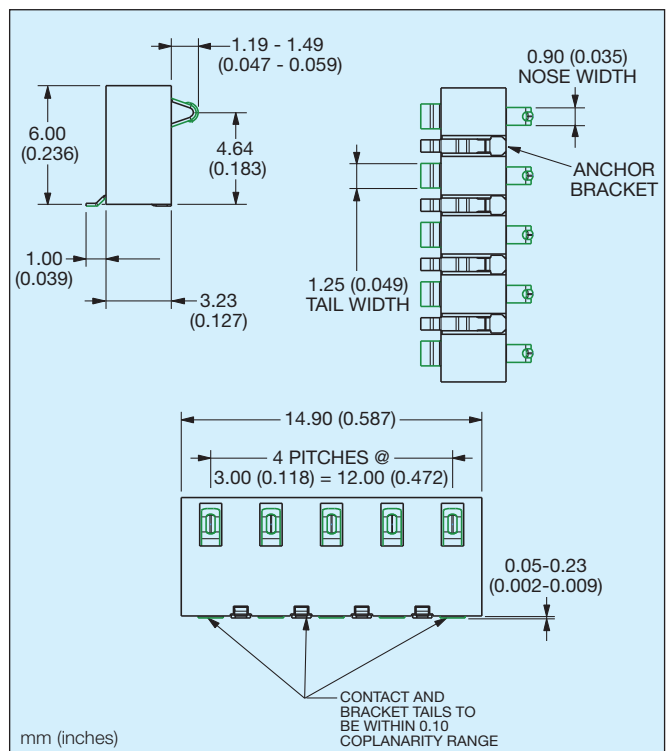

9155 MOBO[®] 3.0mm Pitch Right Angle Battery Connectors



2 Way Right Angle Battery Connector PCB Layout

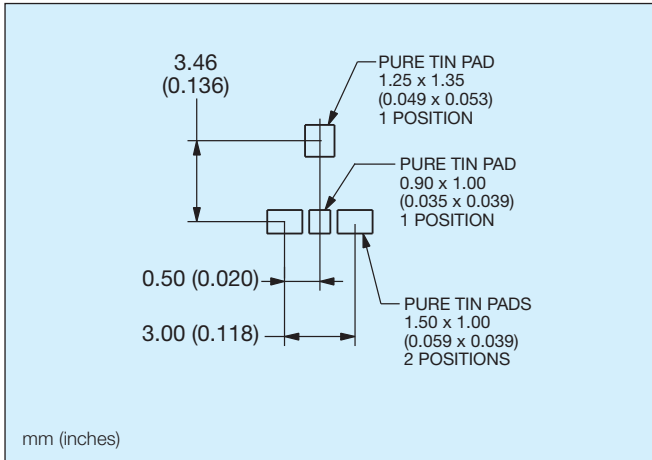

3 Way Right Angle Battery Connector PCB Layout

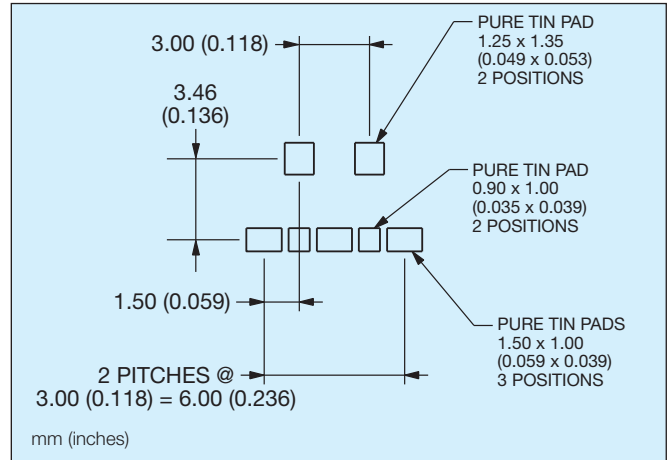

4 Way Right Angle Battery Connector PCB Layout

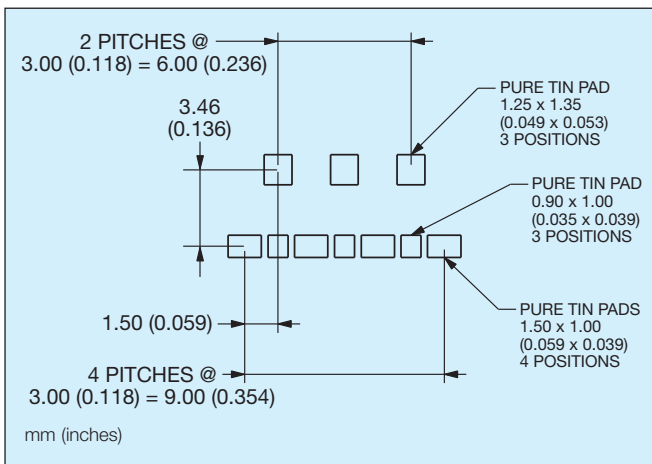

5 Way Right Angle Battery Connector PCB Layout

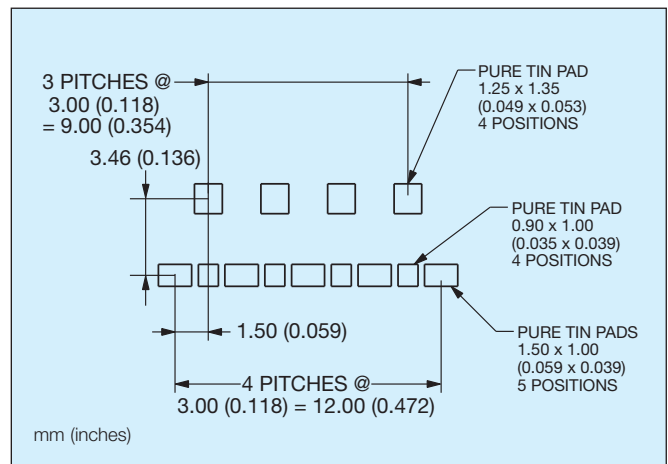

9155 MOBO[®] 2.5mm Pitch Right Angle Battery Connector



GENERAL DESCRIPTION

AVX extends the battery connector range with the addition of a low profile 2.5mm pitch right angle connector. This connector is offered in 2 to 5 positions and is rated at 3 amps. The connector's design is small and compact to minimize its profile yet functionally stable having a contact point at 2.20mm above the PCB.

The unique design of this stamped contact allows for a maximum insulator height of 4.0mm which makes it size compatible with more expensive pogo pin style battery connectors.

The complete family of battery connectors from AVX offer all of the same advantages; Beryllium Copper base material for enhanced contact performance, a full 3 amp current rating, selective gold plating for 5000 mating cycles and high temperature plastic for RoHS soldering.

APPLICATIONS

- Mobile Phones
- Digital Music Players
- Any Handheld Devices

KEY FEATURES AND BENEFITS

- Reliable stamped contact with coined nose
- Full 1.5mm nose deflection for large operating range
- Two anchor tabs for mechanical stability
- 5000 cycle durability rating
- Minimized X, Y and Z package dimensions



HOW TO ORDER

00	9155	002	541	XXX
Prefix	Series	No. of Ways	Right Angle Battery Connector	Plating Option

Code	No. of Ways
002	2
003	3
004	4
005	5

Code	Description
541	Right Angle 2.5mm Battery Connector

Code	Description
006	0.4µm Selective Gold, Pure Tin Tail
008	0.8µm Selective Gold, Pure Tin Tail

9155 MOBO[®] 2.5mm Pitch Right Angle Battery Connector



2 Way Right Angle Battery Connector

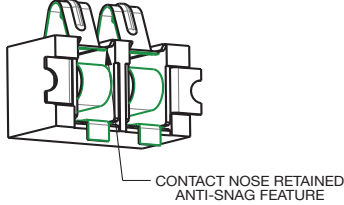
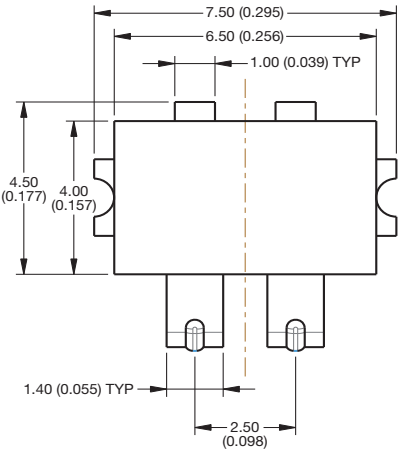

DEFLECTED CONNECTOR

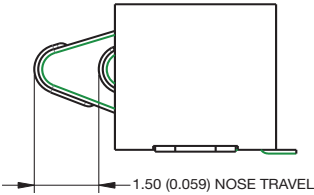

UNDEFLECTED CONTACT

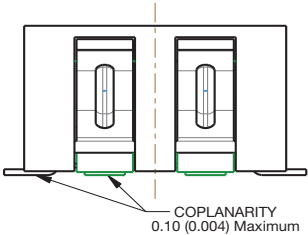
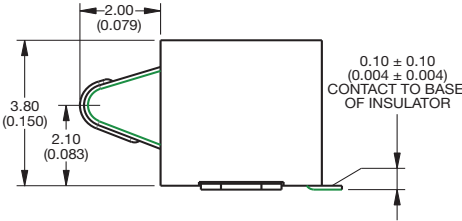

3 Way Right Angle Battery Connector

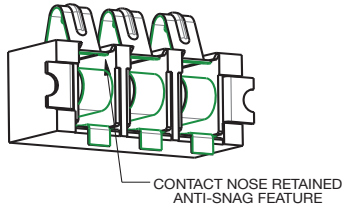
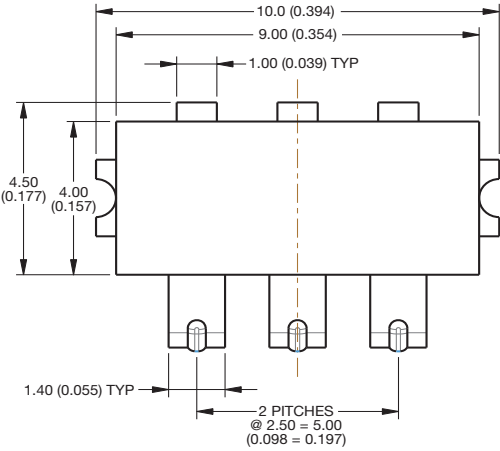

DEFLECTED CONNECTOR

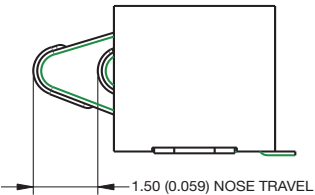

UNDEFLECTED CONTACT

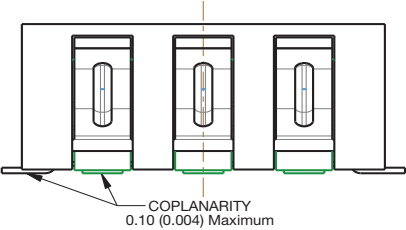
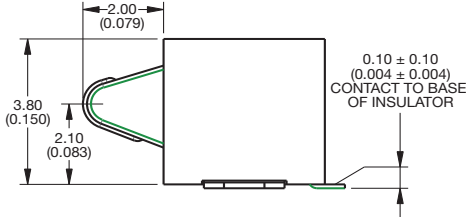

9155 MOBO[®] 2.5mm Pitch Right Angle Battery Connector



4 Way Right Angle Battery Connector

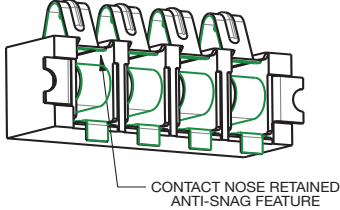
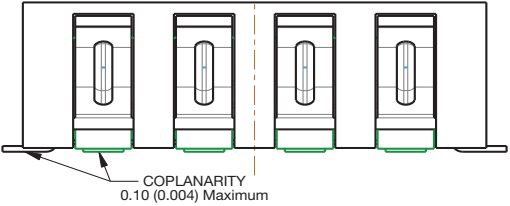
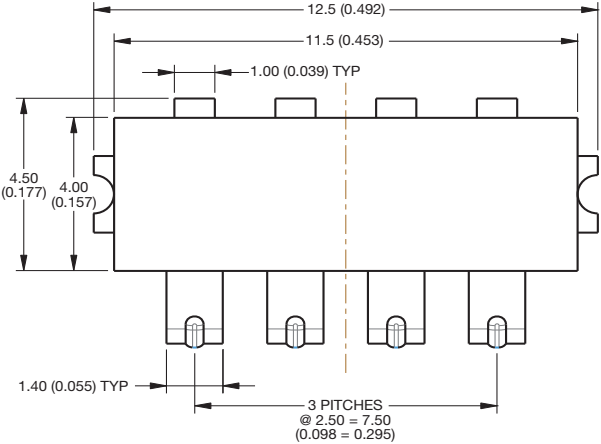

DEFLECTED CONNECTOR

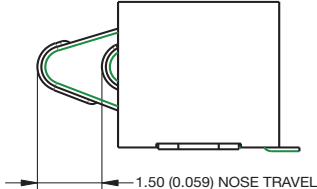

UNDEFLECTED CONTACT

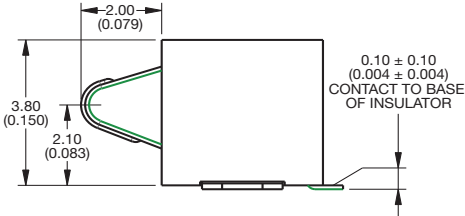

5 Way Right Angle Battery Connector

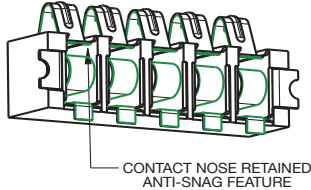
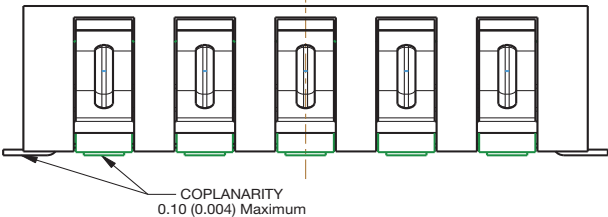
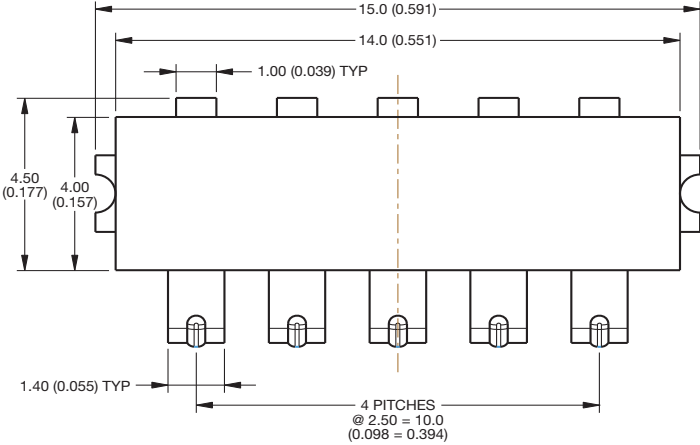

DEFLECTED CONNECTOR

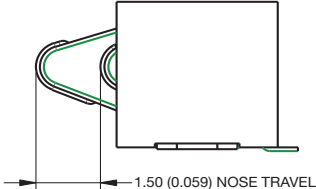

UNDEFLECTED CONTACT

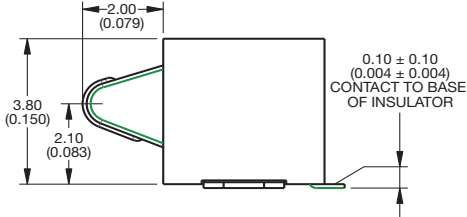

9155 MOBO[®] 2.5mm Pitch Right Angle Battery Connector



**2 Way Right Angle Battery Connector
PCB Layout**

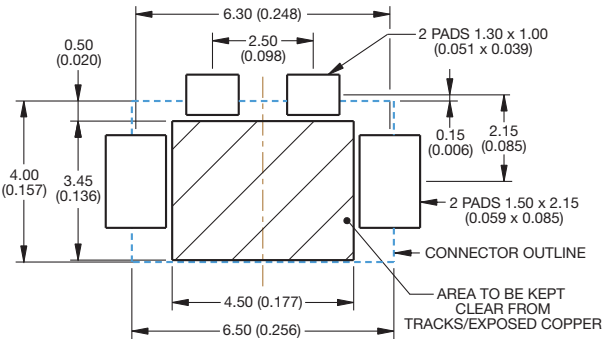

**3 Way Right Angle Battery Connector
PCB Layout**

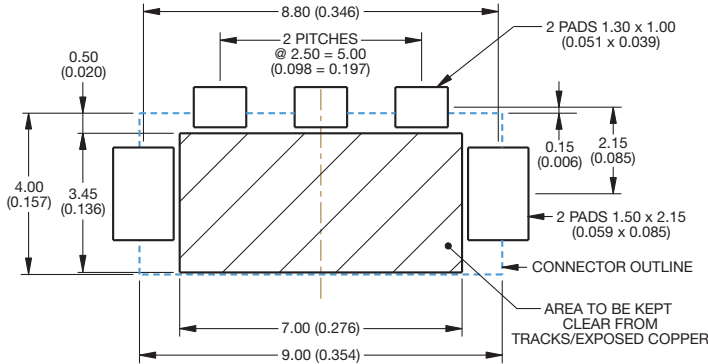

**4 Way Right Angle Battery Connector
PCB Layout**

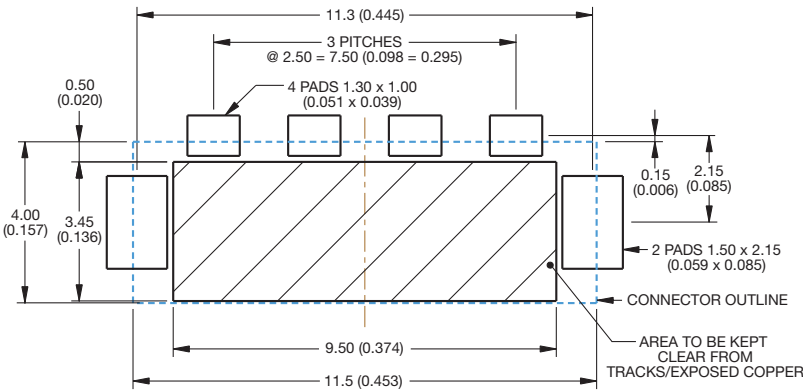

**5 Way Right Angle Battery Connector
PCB Layout**

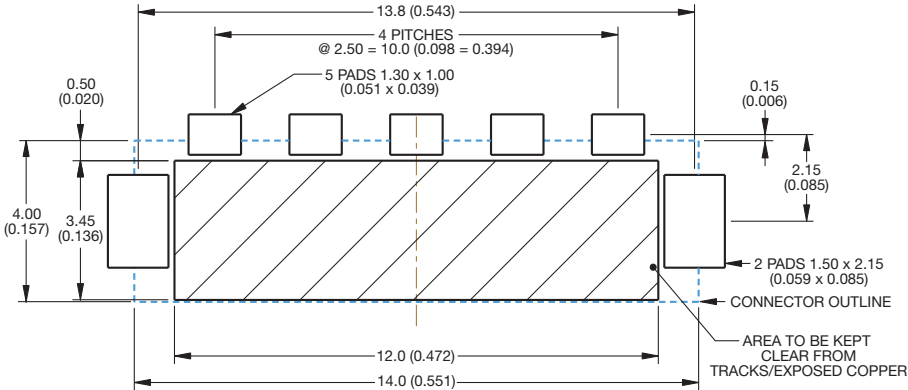



GENERAL DESCRIPTION

The standard SIM connector is specifically designed for handheld devices requiring secure subscriber identification.

Following on from the introduction of our standard SIM block with an offering of 3 standard heights, 0.80mm, 1.60mm, or 2.40mm, AVX is now adding another standard to the 9162 series SIM connectors, the slide-in SIM.

Unlike SIM blocks which require SIM card guides to aid insertion, removal and retention of the SIM card, the slide-in SIM has guides as part of the connector mold design.

Contacts are stamped, gold plated, rated 0.5A, and 5000 mechanical cycles.

Our contact design is specifically rounded to avoid any possible damage during and after card insertion to the card itself, assuming normal use. The design also incorporates protection features to avoid contact damage during this operation such as contact snagging.

Please contact the appropriate sales office for further details of this service.

KEY FEATURES AND BENEFITS

- Produced for use with mini SIM cards.
- The insulator is molded from high temperature plastic enabling the connector to be used in convection or infrared soldering processes.
- Supplied on tape and reel packaging for pick and place assembly.
- The all plastic design, assuming normal use prevents damage to the SIM card on insertion.
- Optional SMT contact size:
 - Standard SMT contact size – 1.60mm x 1.60mm
 - Narrow SMT contact size – 1.05mm x 0.60mm
- RoHS Compliant available.



Standard SMT Contact Layout

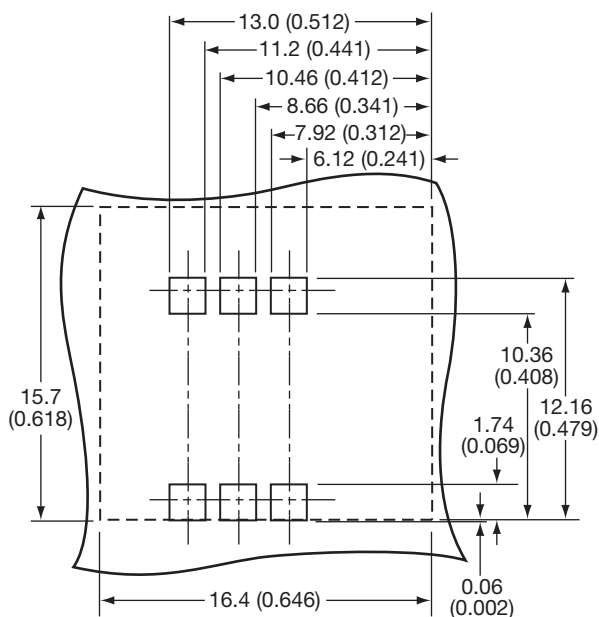

Narrow SMT Contact Layout

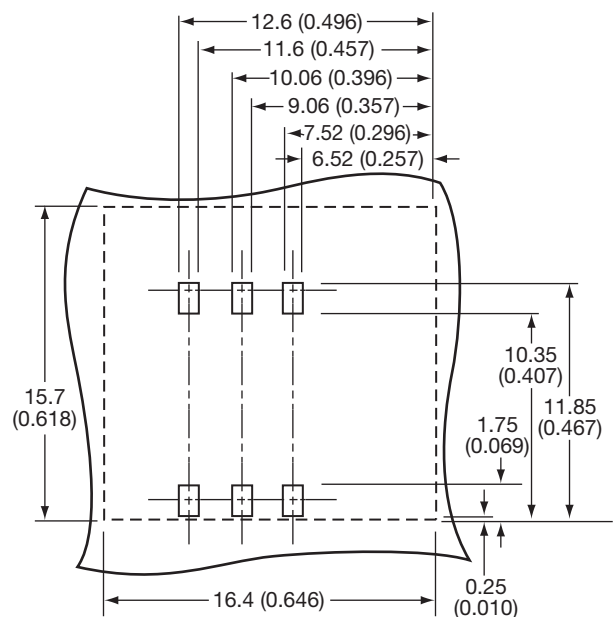

9162 Slide-In SIM Card Connector



Connector Height 1.75mm

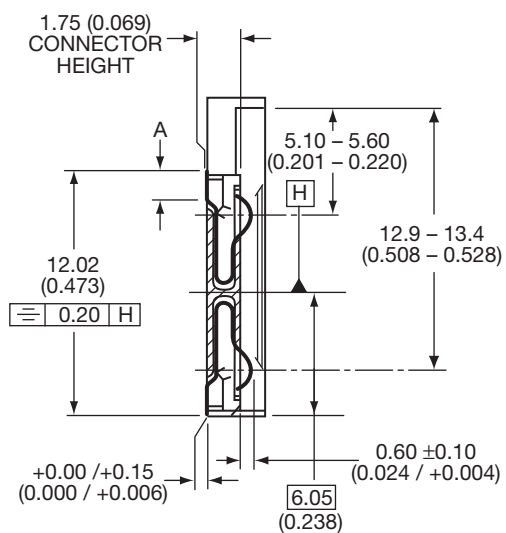

SECTION Z-Z

	Standard	Narrow
A	1.46 (0.057)	1.05 (0.041)
B	1.60 (0.063)	0.60 (0.024)

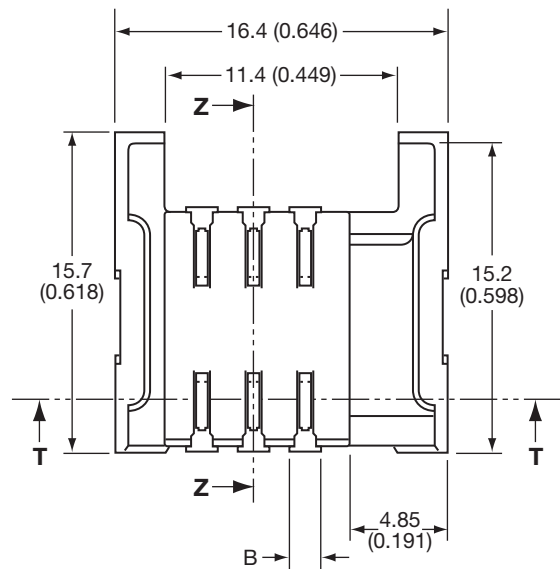

SECTION T-T

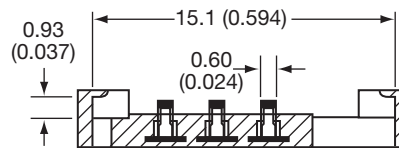

HOW TO ORDER

00

Prefix

00 = Standard
58 = Special

9162

Series

006

No. of Contacts

006 = 6

2X 6

SIM Type

20 = Standard SMT Footprint
21 = Narrow SMT Footprint

Plating Options

Selective Gold,
Pure Tin Tail

XXX

Connector Height

XXX refers to
Connector Height
175 = 1.75mm stack height

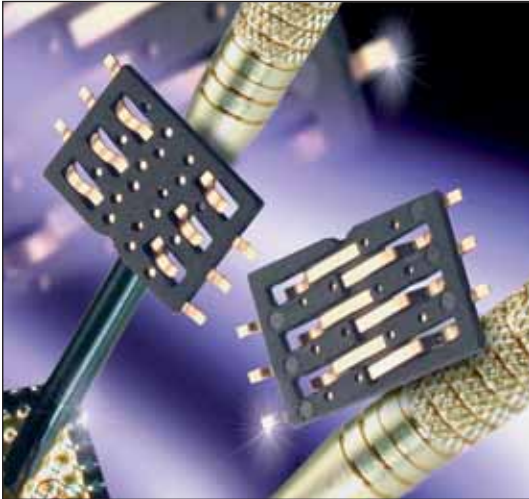

GENERAL DESCRIPTION

The standard SIM connector is specifically designed for handheld devices requiring secure subscriber identification.

The connectors are available in a standard 6 pin configuration on a 2.54mm pitch with a 0.8mm height.

Contacts are stamped, gold plated, rated at 0.5A, and 5000 mechanical cycles.

Our contact design is specifically rounded to avoid any possible damage during and after card insertion to the card itself, assuming normal use. The design also incorporates protection features to avoid contact damage during this operation such as contact snagging.

Please contact the appropriate sales office for further details.

KEY FEATURES AND BENEFITS

- Produced for use with both full ISO cards and mini SIM cards.
- The insulator is molded from high temperature plastic enabling the connector to be used in convection or infrared soldering processes.
- Supplied on tape and reel packaging for pick and place assembly.
- RoHS Compliant.



0.8mm PCB Pad Layout

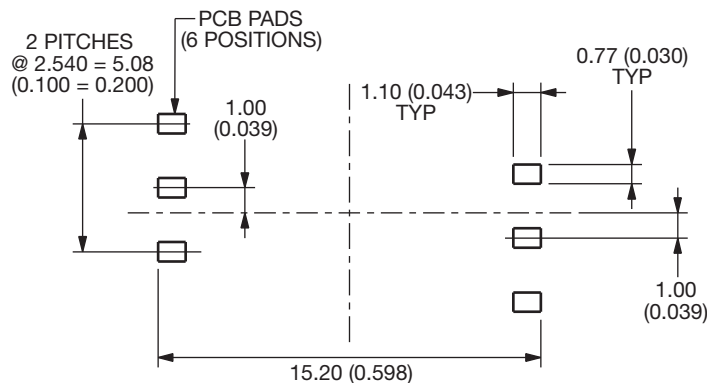

Connector Height 0.8mm

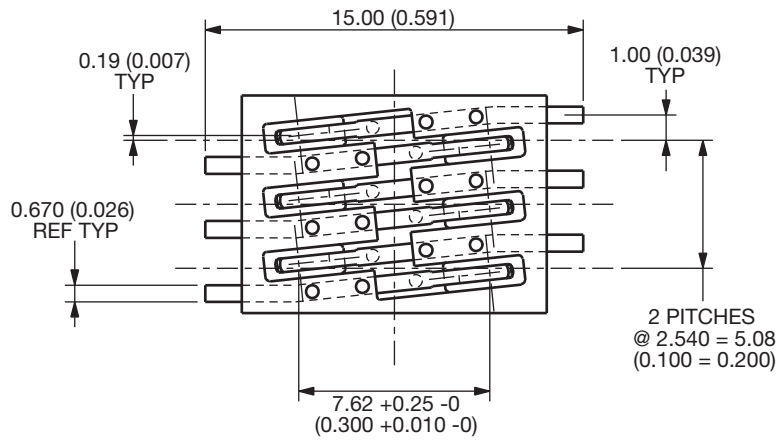
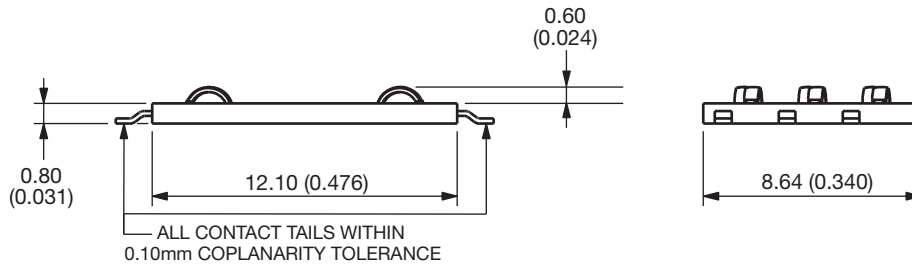
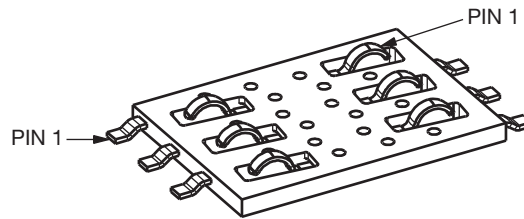

Illustration of Pin Configuration



HOW TO ORDER

00

Prefix

9162

Series

006

Number of Contacts

006

SIM Type
006 = Selective Gold,
Pure Tin Tail

080

Connector Height
080 = 0.8mm stack height

9162 SIM Connector with Locking Latch



GENERAL DESCRIPTION

For 9162 Slide-IN & 9162 SIM/microSD

- Accepts GSM Standard 11.11 cards
- Secure locking latch mechanism
- Robust, good resistance against shock and vibration
- SIM Installed Height – 1.50mm
- Polarized to eliminate improper insertion of the card

KEY FEATURES AND BENEFITS

- SMT with locking hinged guide
- 2.50mm connector height
- Selective gold on mating surface/tin on solder tails
- Tape and reel packaging



HOW TO ORDER

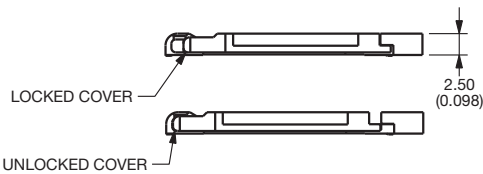
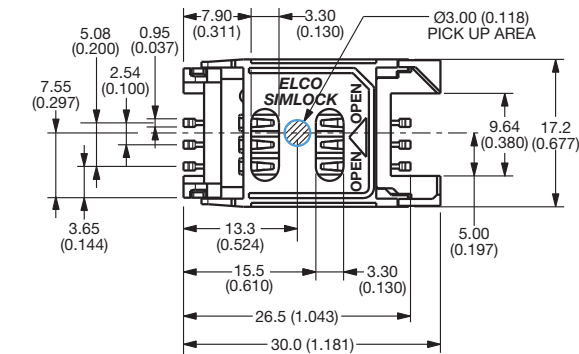
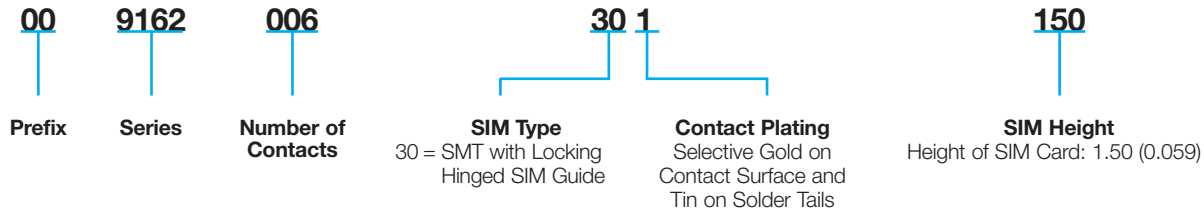

MAXIMUM COPLANARITY 0.10 (0.004) BETWEEN CONTACT PADS

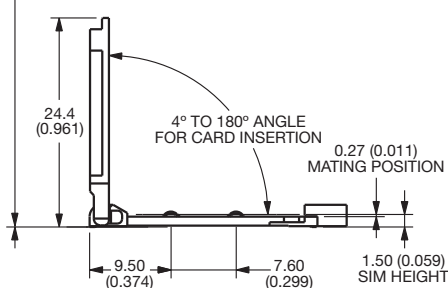

Suggested PCB Layout

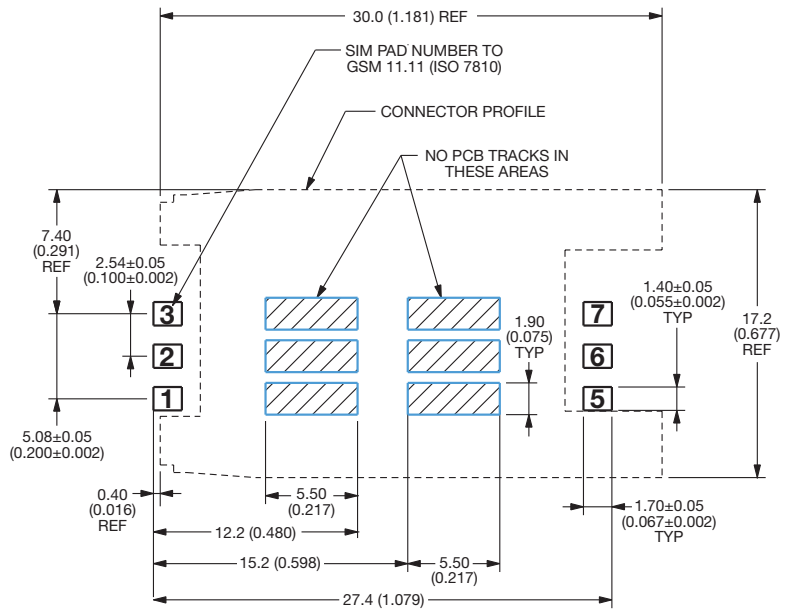

9162 Slide-In Low Profile SIM Connector

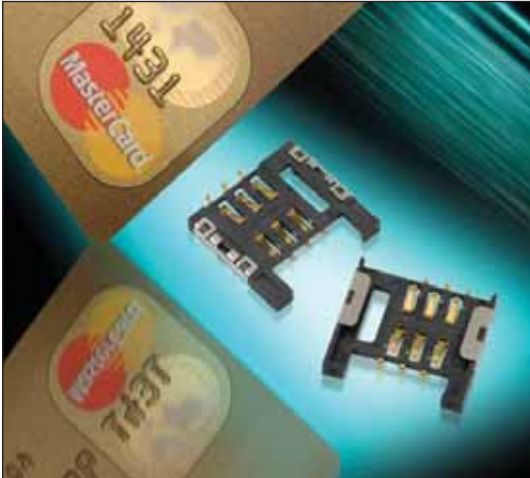

GENERAL DESCRIPTION

- Six position Slide-In SIM
- Low Profile – 0.70mm to SIM base
- Side bracket to add solder security
- SIM guidance using the side walls

KEY FEATURES AND BENEFITS

- SMT Slide-In SIM
- Molded in high temperature LCP
- 0.38µm Gold on contact surface and gold flash on contact tails
- 1.60mm connector height
- Tape & Reel packaging



HOW TO ORDER

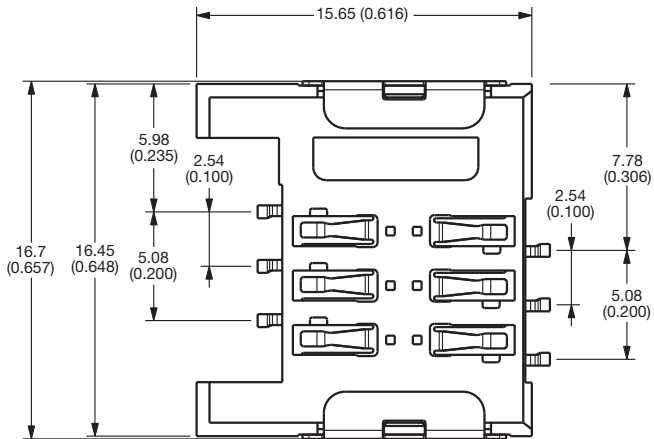
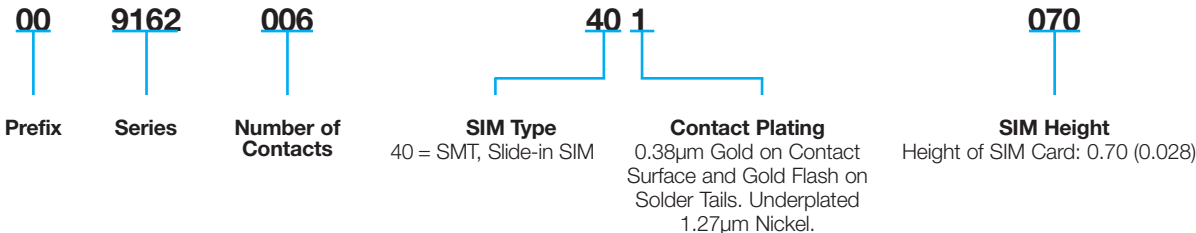

Suggested PCB Layout

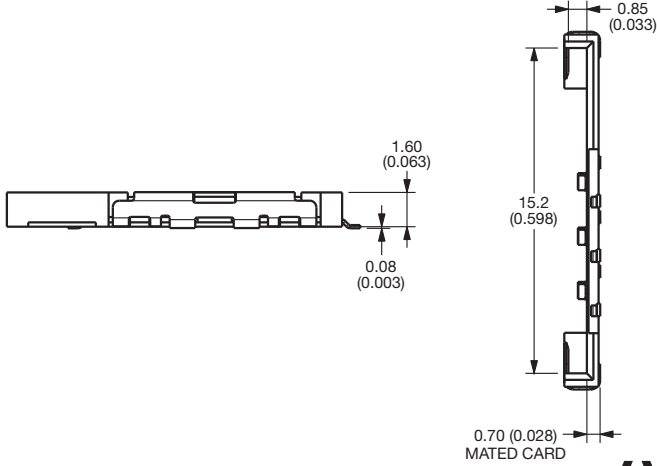
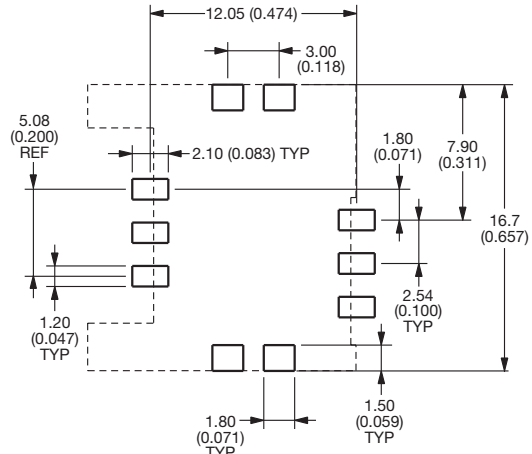

9162 SIM/microSD Micro Combination Connector



GENERAL DESCRIPTION

- Six position slide-in SIM connector & Push-Push microSD connector
- Allows two cards to be inserted into the same connector
- Card detect switch on the microSD

KEY FEATURES AND BENEFITS

- Space saving connector combination
- Integrates 2 connectors into 1
- Contact Plating: Gold
- Insulator molded from LCP UL94 V-O
- Low profile 1.50mm to SIM
- 2.70mm connector height



HOW TO ORDER

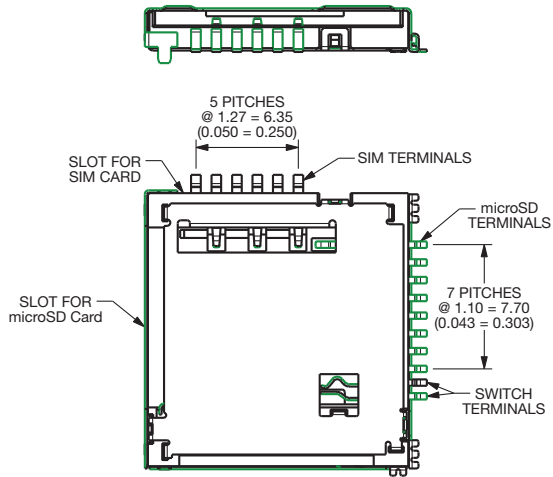
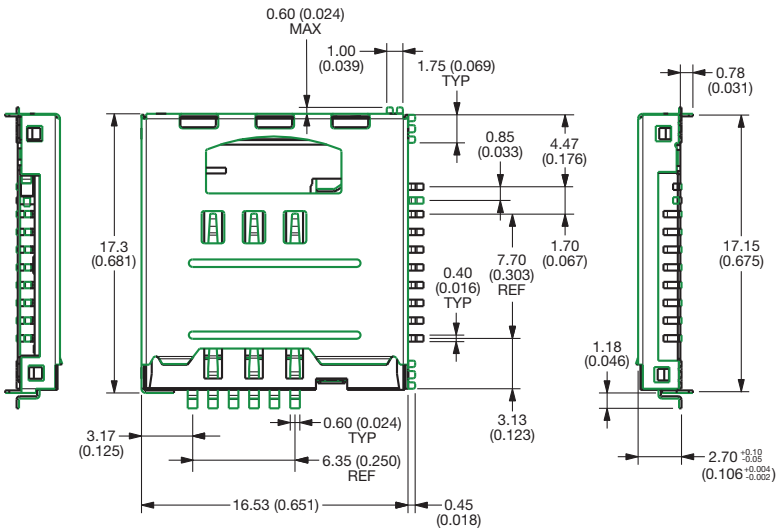
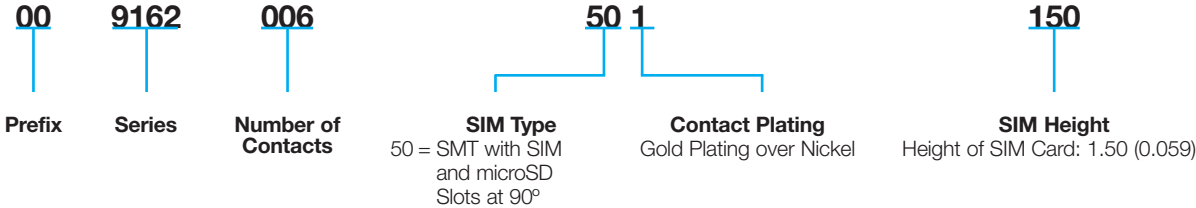

9162 SIM/microSD Micro Combination Connector



Connector on PCB

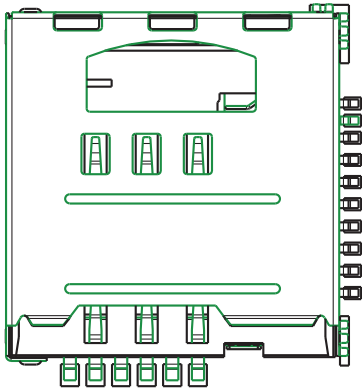

Recommended PCB Layout

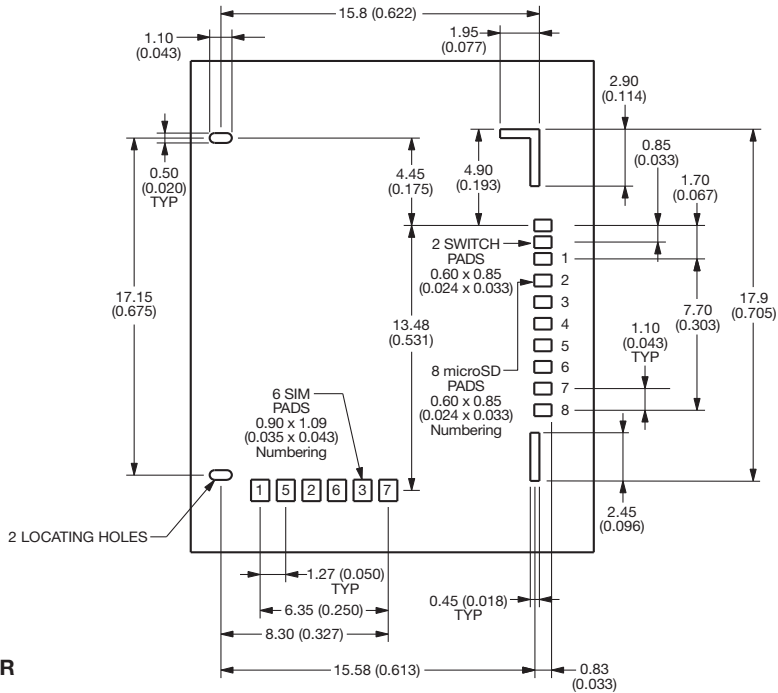

PCB SPACE USED BY CONNECTOR CARDS FULLY INSERTED

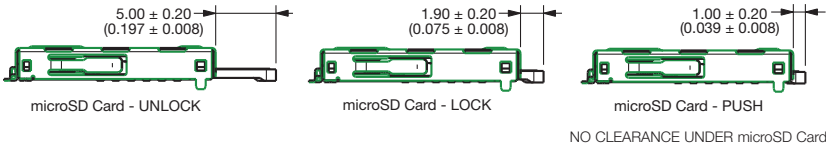

CARDS EXTRACTED

(Shown for reference only)

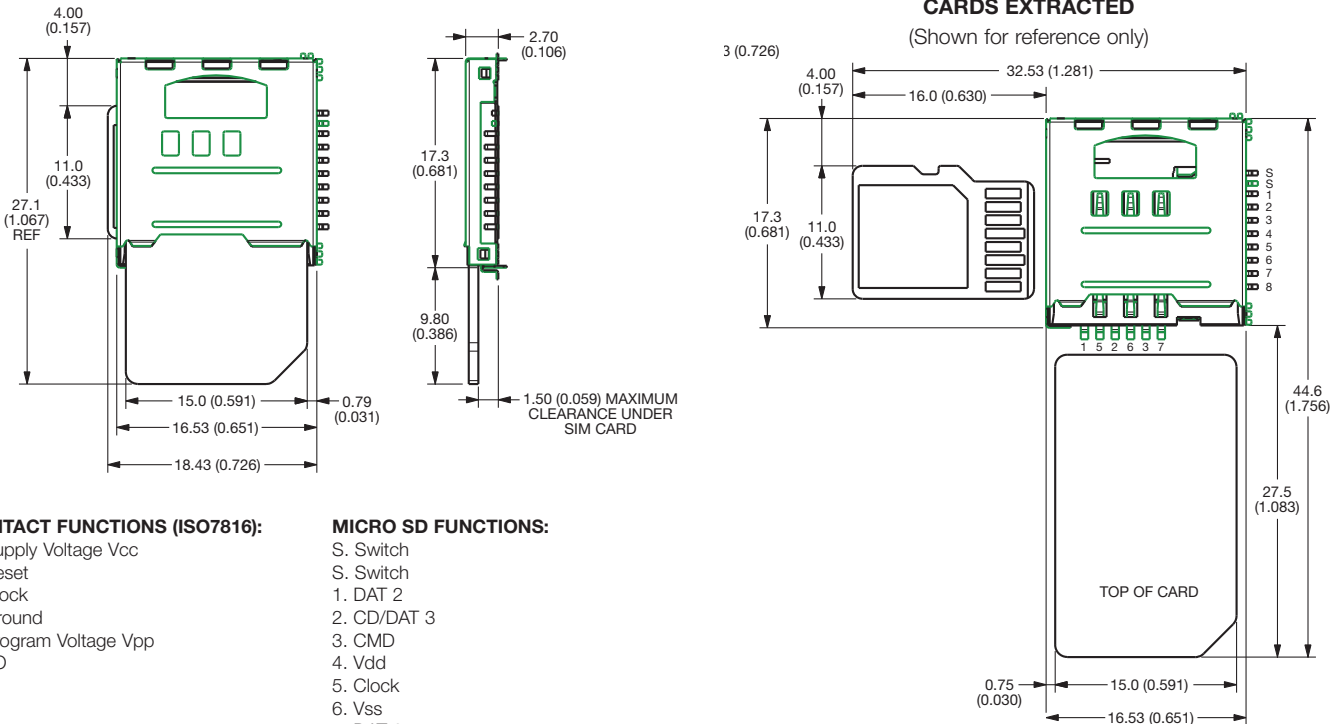

CONTACT FUNCTIONS (ISO7816):

1. Supply Voltage Vcc
2. Reset
3. Clock
5. Ground
6. Program Voltage Vpp
7. I/O

MICRO SD FUNCTIONS:

- S. Switch
- S. Switch
1. DAT 2
2. CD/DAT 3
3. CMD
4. Vdd
5. Clock
6. Vss
7. DAT 0
8. DAT 1



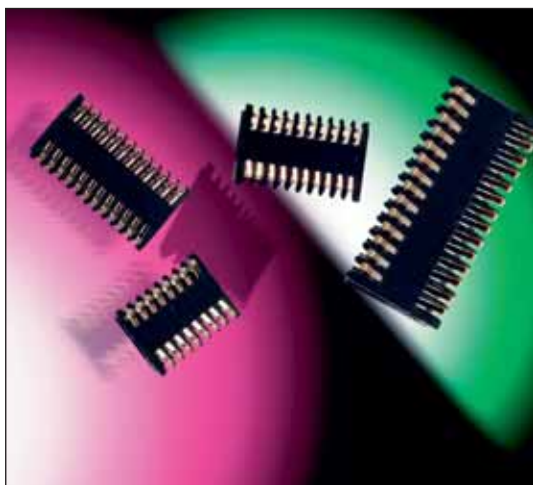

GENERAL DESCRIPTION

The MOBO® series 9158 is a one-piece connector used to connect two PCBs within mobile phones, pagers, PDAs, security, handheld scanners, etc. in a cost-effective manner.

A standard range is available with 16, 20, 24 and 28 contacts to suit stack heights of 1.90mm to 3.30mm. Other contact variants are also available up to 5.10mm, in custom housings. The SOLO STACKER can allow a spacing tolerance of up to ± 0.30 mm and still provide reliable connections between the PCBs, even if they are not parallel.

SOLO STACKER is designed for PCB surface mounting and is supplied in tape and reel packaging. Gold plated pads on the mating PCB or suitable flex circuits provide connection between the boards.

Whatever your requirements this SOLO STACKER can also be customized to suit your applications.

APPLICATIONS

Suitable applications include:

- Mobile Phones
- PDA
- Medical
- PMR
- Industrial
- Security
- Handheld Scanner

KEY FEATURES AND BENEFITS

Single piece Connector – no mating half connector required to connect two boards together which means:

- Reduced assembly time.
- Only one part to purchase and stock.
- Due to the unique contact design, the mating device does not have to be parallel.
- Extremely robust when subjected to shock and vibration.
- Cost effective.
- Helps reduce tolerance accumulation within system.



DRAWINGS AND DIMENSIONS

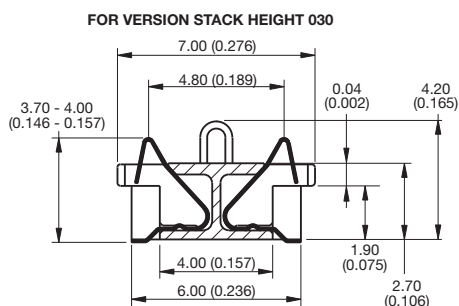
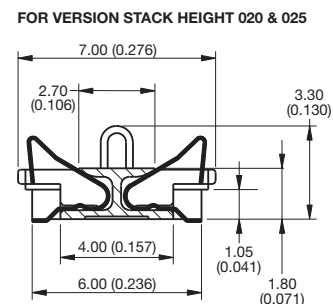
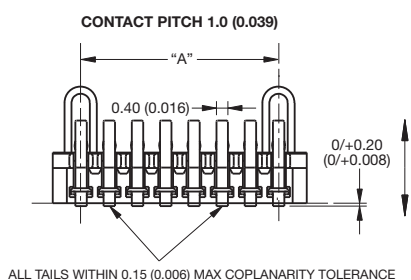
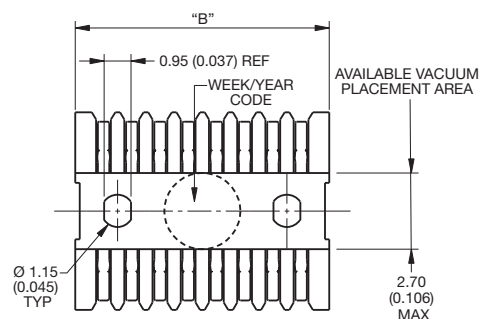

Number of Positions	Part Number	A	B
16	00-9158-016-XXX-XXX	7	9.00
20	00-9158-020-XXX-XXX	9	11.00
24	00-9158-024-XXX-XXX	11	13.00
28	00-9158-028-XXX-XXX	13	15.00

A = Number of contact pitches at 1mm
B = Connector Length

SMT PCB Footprint

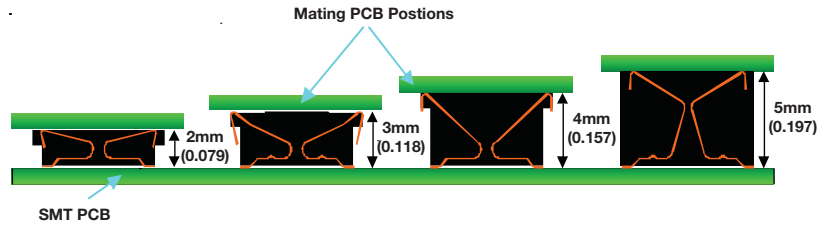
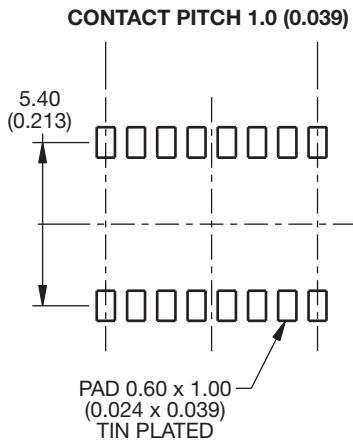

Mating Height	Standard Positions				Special Positions*				
	16	20	24	28	4	18	30	32	40
2mm	X	X	X	X					
3mm	X	X	X	X				X	
4mm					X	X			X
5mm							X		

Other sizes available on request.
*Please consult with factory for availability.

Mating PCB Footprint for version stack height 020 & 030

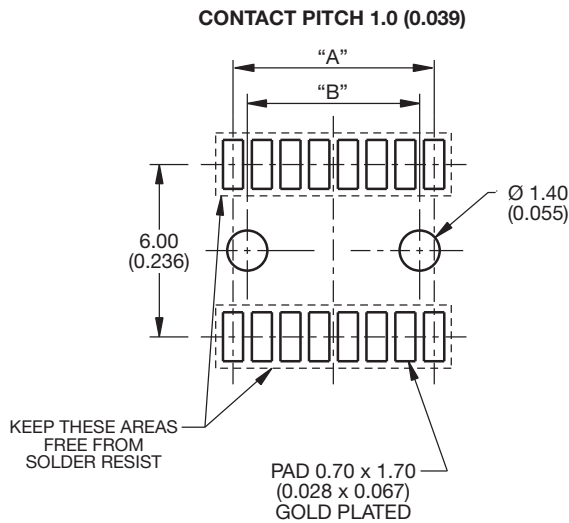

Mating PCB Footprint for version stack height 025

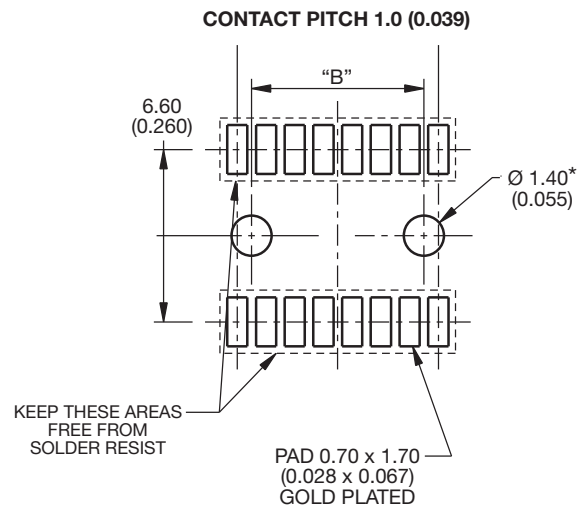

* Used for Boss versions only.

B	Dim
16	6.00 (0.236)
20	8.00 (0.315)
24	10.00 (0.394)
28	12.00 (0.472)

HOW TO ORDER

00	9158	XXX	XXX	06	X
Prefix	Series	No of Ways	Stack Height	Plating Variation	PCB Location Bosses
00 = Standard		16 = 016 20 = 020 24 = 024 28 = 028	020 = 1.9mm to 2.1mm 025 = 2.1mm to 2.7mm 030 = 2.8mm to 3.3mm	06 = Selective Gold 0.25µm Gold Plated Contact Nose, Pure Tin Tail	1 = With PCB Location Bosses 2 = Without PCB Location Bosses

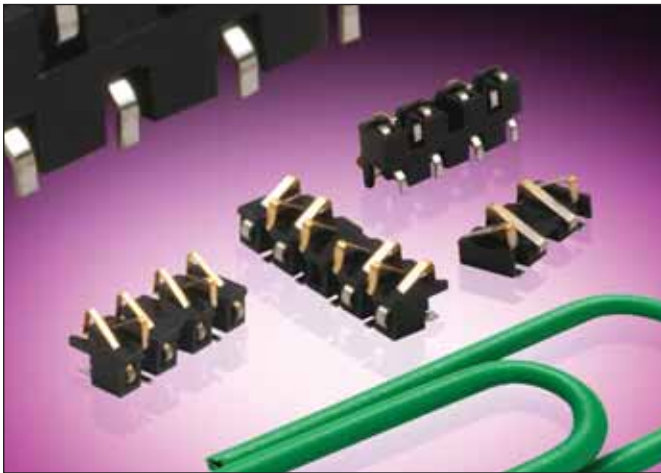

GENERAL DESCRIPTION

The SOLO series 9188 is a one-piece connector used to connect two PCBs in a cost effective manner.

A standard range is available with 4, 6, 8 staggered contacts to suit stack heights of 1.1mm to 2.1mm (see table below).

SOLO Stacker is designed for PCB surface mounting and is supplied in tape and reel packaging. Gold plated pads on the mating PCB or suitable flex circuits provide connection between the two boards.

APPLICATIONS

Suitable applications include:

- Handheld Devices:
 - Phones
 - Scanners
 - Radios
 - Medical Diagnostic
 - Security Devices

KEY FEATURES AND BENEFITS

Single piece connector – no mating half required to connect two boards together which means:

- Reduced assembly time
- Only one part to purchase and stock
- Due to the unique contact design, the mating device does not have to be parallel
- Helps reduce tolerance accumulation within system

HOW TO ORDER



00

Prefix

9188

Series

004

No. of Ways

Code	No. of Ways
004	4
006	6
008	8

012

Stack Height

Code	Height	No. of Ways
012	1.1mm to 1.3mm	4 only
020	1.9mm to 2.1mm	6 & 8 only

062

Plating Variation

06 = Selective Gold
0.25µm
Gold Plated
Contact Nose,
Pure Tin Tail
No Bosses

4 Way Staggered Stacker

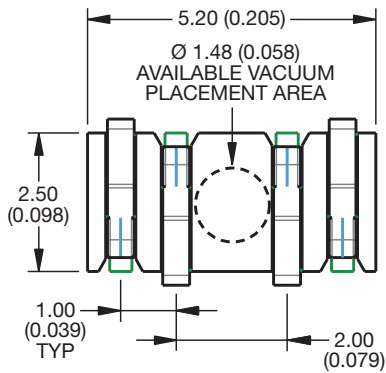

MATING CONDITION

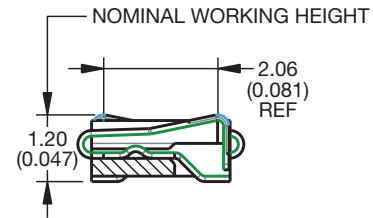

SECTION ON X - X

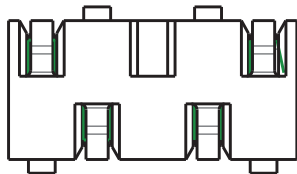
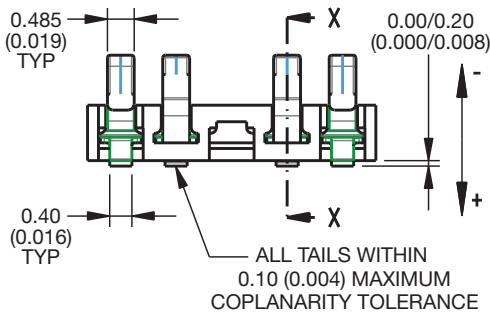
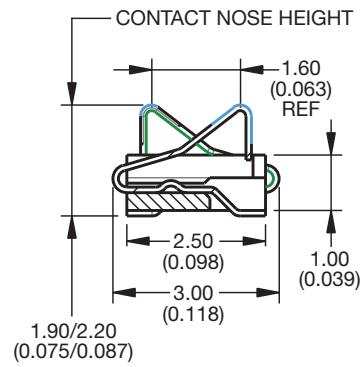

SMT PCB FOOTPRINT

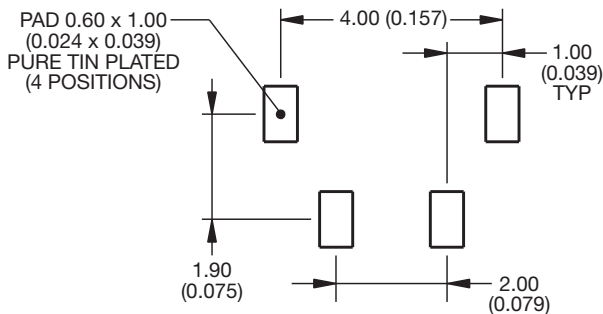

MATING PCB FOOTPRINT

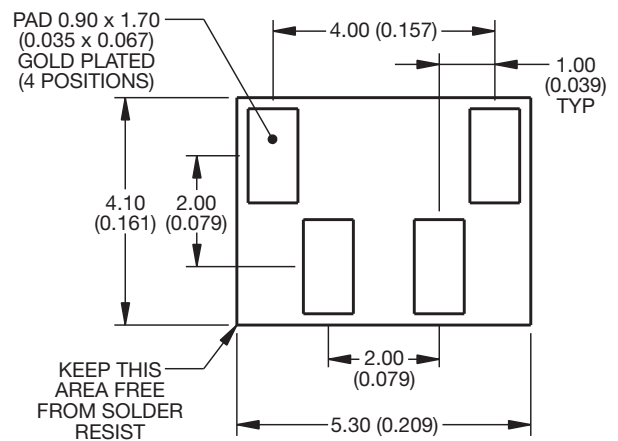

6 Way Staggered Stacker

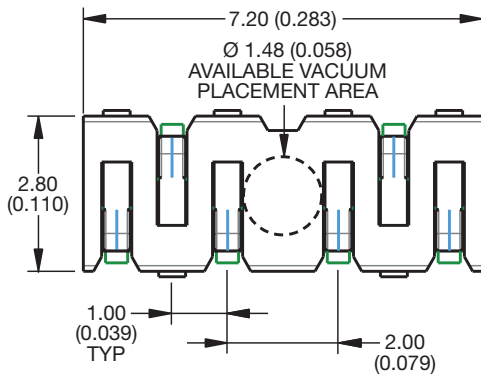

MATING CONDITION

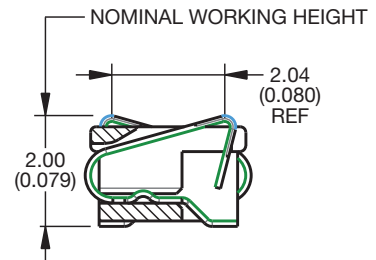

SECTION ON X - X

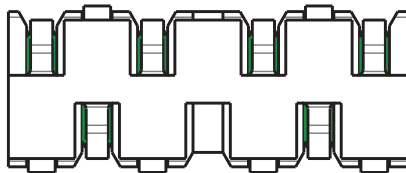
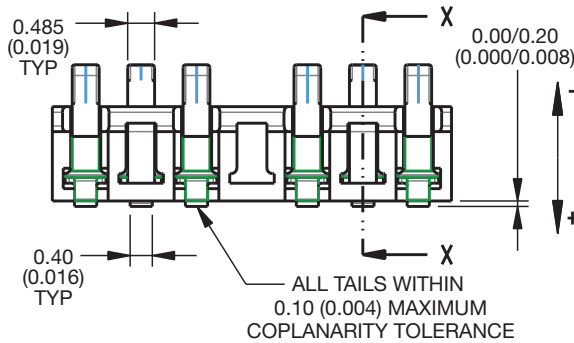
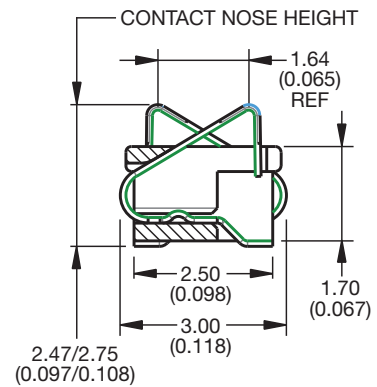

SMT PCB FOOTPRINT

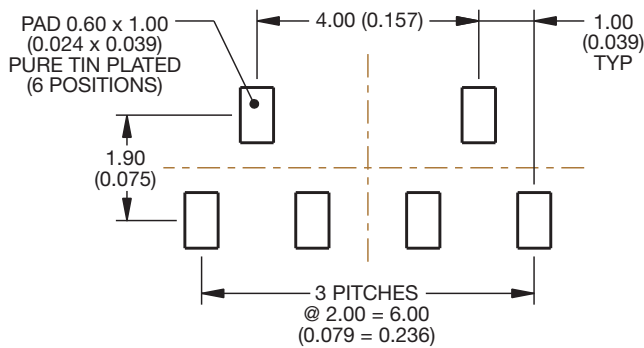

MATING PCB FOOTPRINT

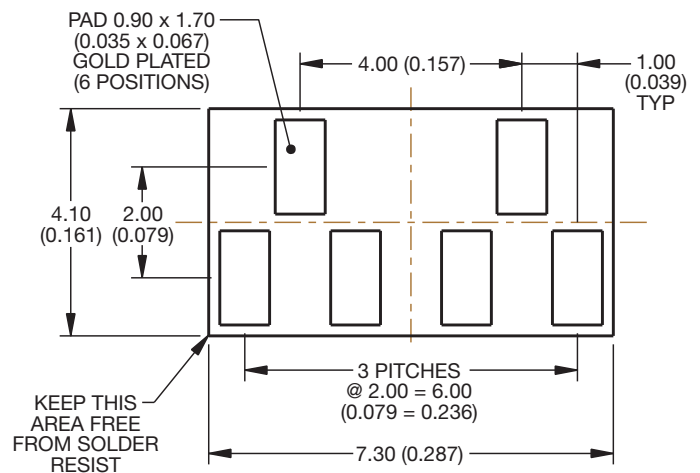

8 Way Staggered Stacker

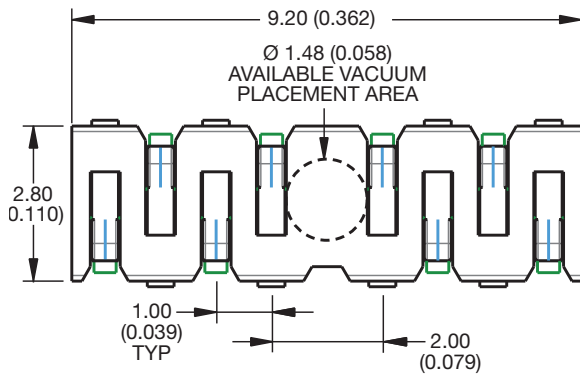

MATING CONDITION

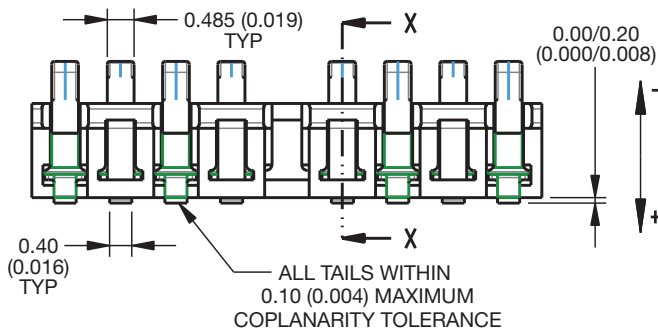
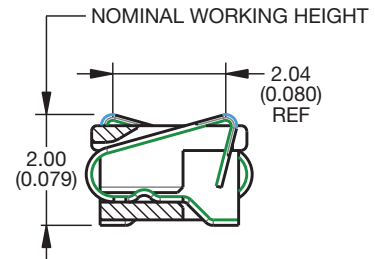

SECTION ON X - X

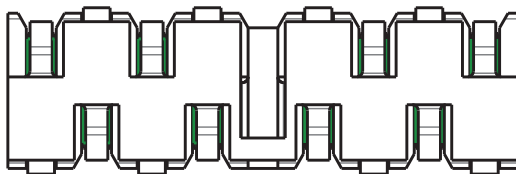
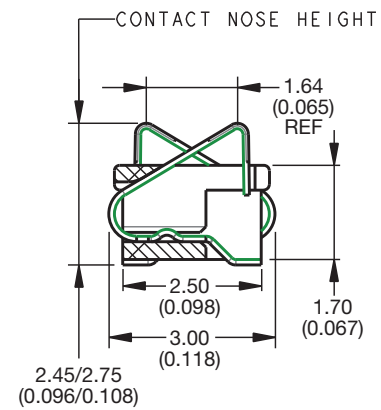

SMT PCB FOOTPRINT

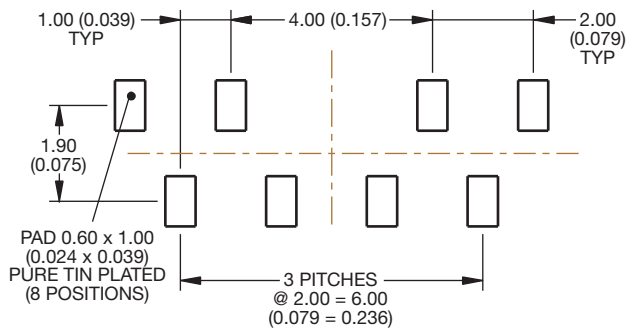

MATING PCB FOOTPRINT

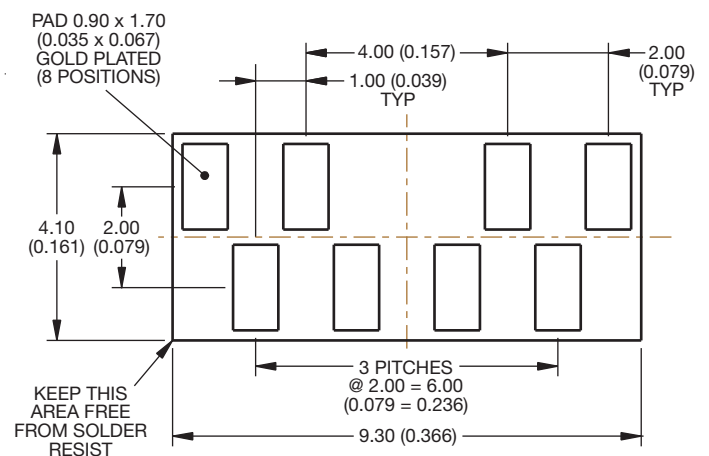

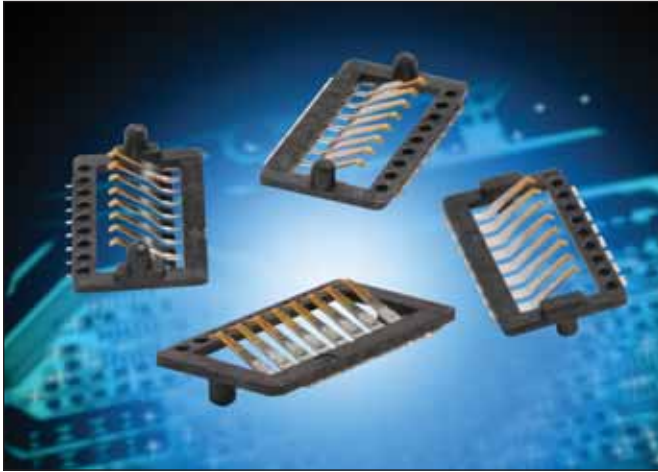

GENERAL DESCRIPTION

The SOLO series 9258 is a one-piece connector used to connect two PCBs in a cost effective manner.

This connector is a 1.0mm pitch available in an 8 position with stack heights of 0.40mm and 0.80mm. It is available with or without location bosses.

This connector is designed for PCB surface mounting and is supplied in tape and reel packaging. Gold plated pads on the mating PCB or suitable flex circuits provide connection between the boards.

APPLICATIONS

Suitable applications include:

- Mobile phones
- Handheld scanners
- Portable medical devices
- Display interface

KEY FEATURES AND BENEFITS

Single piece connector – no mating half connector required to connect two boards together which means:

- Reduced assembly time
- Only one part to purchase and stock
- Due to the unique contact design, the mating device does not have to be parallel
- Extremely robust when it comes to shock and vibration

HOW TO ORDER

00	9258	008	XXX	06	X
Prefix 00 = Standard	Series	No of Ways	Stack Height 004 = 0.40mm 008 = 0.80mm	Plating Variation 06 = Selective Gold 0.25µm Gold Plated Contact Nose, Pure Tin Tail	PCB Location Bosses 1 = With Mating PCB Location Bosses (top side) 2 = Without PCB Location Bosses 3 = With SMT PCB Location Bosses (bottom side) 4 = With SMT and Mating PCB Location Bosses (top and bottom sides)



9258 Ultra Low Profile Stacker



0.4mm Ultra Low Profile Stacker

0.8mm Ultra Low Profile Stacker

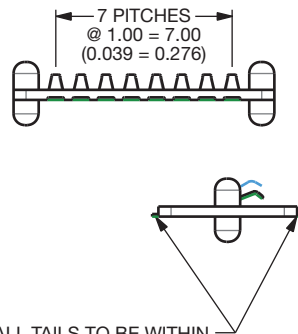
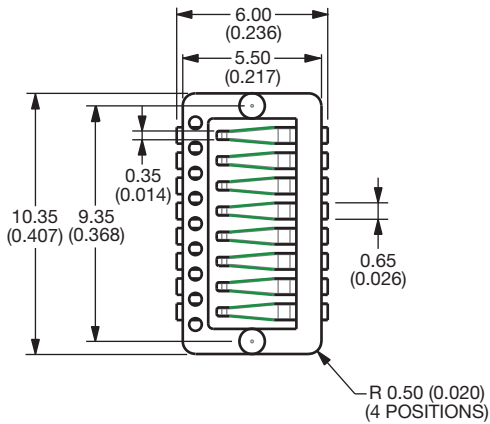

ALL TAILS TO BE WITHIN 0.10 (0.004) MAXIMUM COPLANARITY TOLERANCE

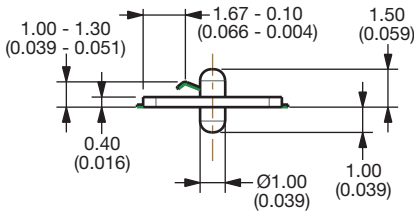
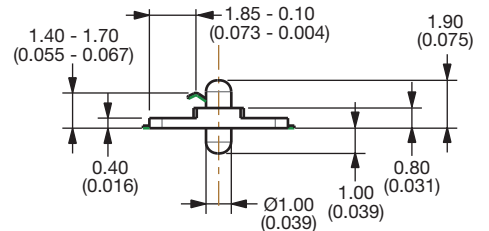
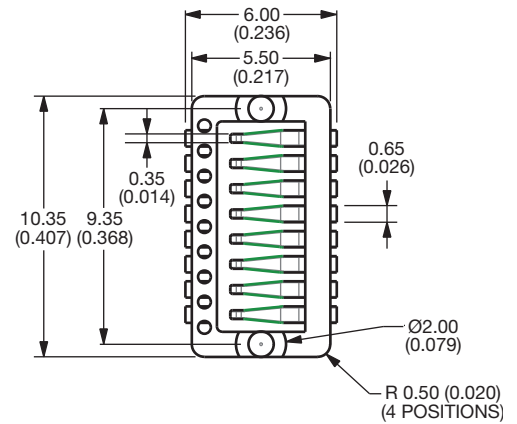

PROPOSED SMT PCB LAYOUT

ALL PADS PURE TIN PLATE

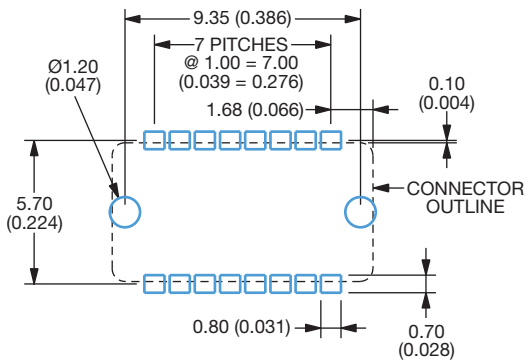

WITH MATING PCB LOCATION BOSSES (TOP SIDE)

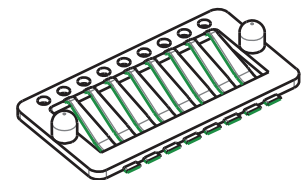

WITHOUT PCB LOCATION BOSSES

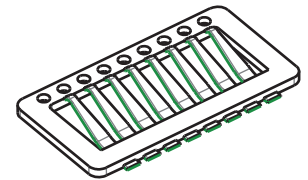

WITH SMT PCB LOCATION BOSSES (BOTTOM SIDE)

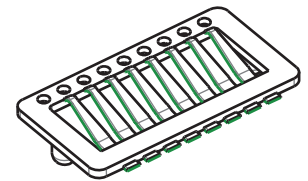

PROPOSED MATING PCB LAYOUT

ALL PADS GOLD PLATE

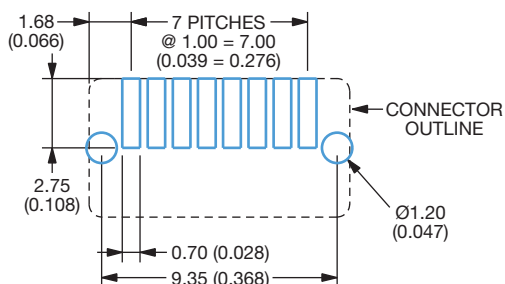

WITH PCB AND SMT LOCATION BOSSES

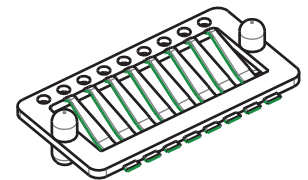



GENERAL DESCRIPTION

The 9157 series was specifically designed for portable equipment.

AVX now offers this two-part system as a standard product. The fixed SMT socket is designed to be housed within the confined dimensional constraints of the portable device.

The plug/cover connector has sprung contacts and is designed for termination to accessory equipment. The connector is designed to house fifteen signal contacts on a 1mm pitch rated at 1.5A. There is the option to include a switching RF coax.

A cradle SMT plug connector for docking applications is also available as standard and has the option of including a SMT RF coax.

Whatever your requirements, the 9157 series can also be customized to suit your application.

APPLICATIONS

Suitable applications include:

- Mobile Phones
- PDA
- Medical
- Docking/Charging for any portable device

KEY FEATURES AND BENEFITS

- Patented 20° angled face on the socket gives self-cleaning face when mated with plug.
- Metal Latching area integral to socket which saves PCB real estate.
- Integral to socket is a mechanical 50Ω switching coax for SMT termination.
- Single sprung plug contact design gives ten thousand mating cycles and cleaning/wiping action.
- Customer has option to terminate own RF coax using AVX custom tooling: 06-9157-7116-01-000.
- SMT plug has unique location pyramids that give positive alignment to portable device, and assist blind mating.
- RoHS Compliant.



Plug Wire with Coax

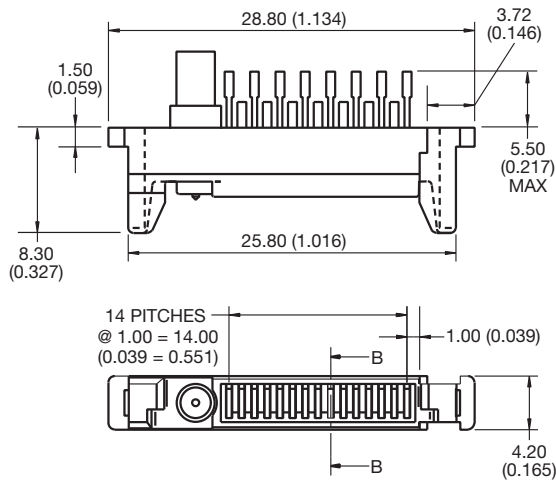

Plug Wire without Coax

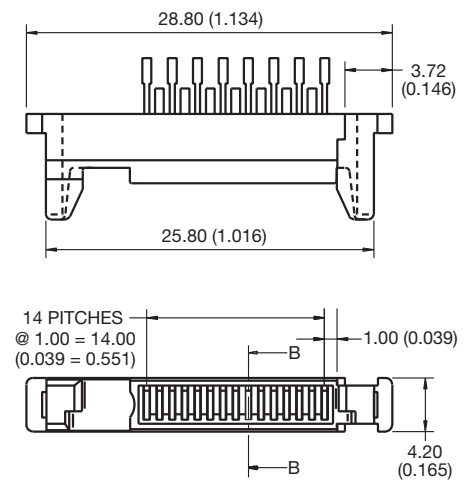

SMT Plug with Coax

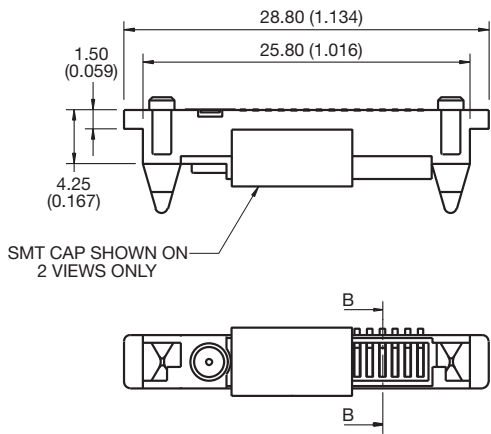

SMT Plug without Coax

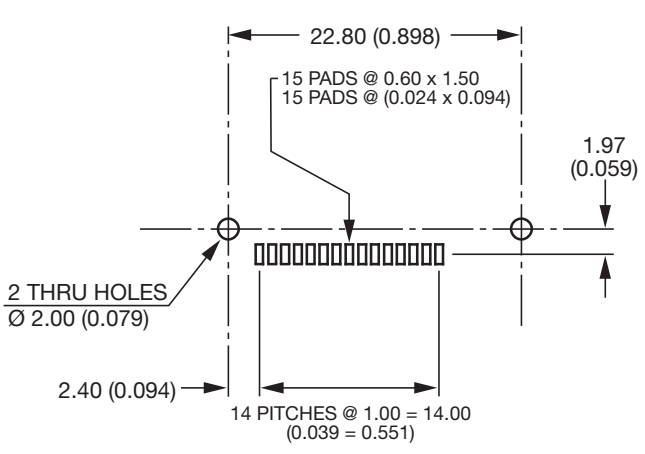
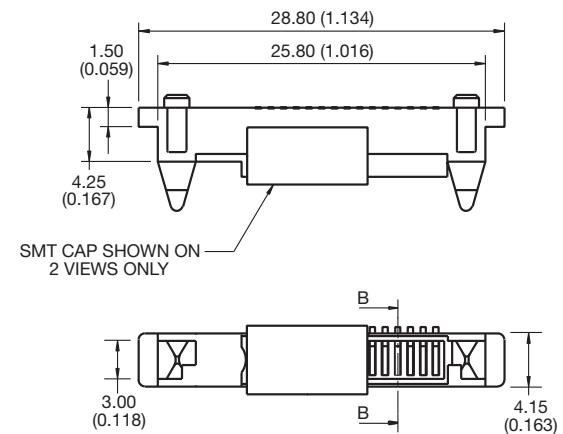

SUGGESTED PCB LAYOUT

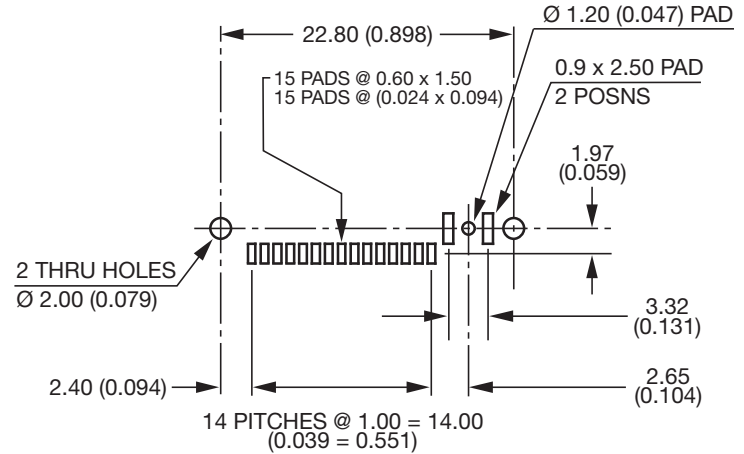

SUGGESTED PCB LAYOUT

SMT Socket with Coax

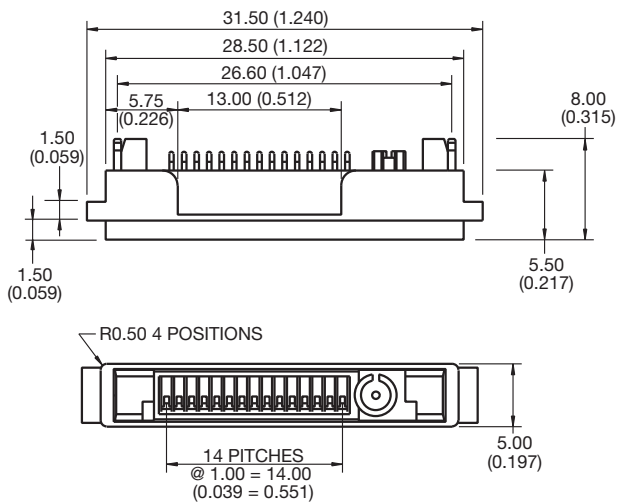

SMT Socket without Coax

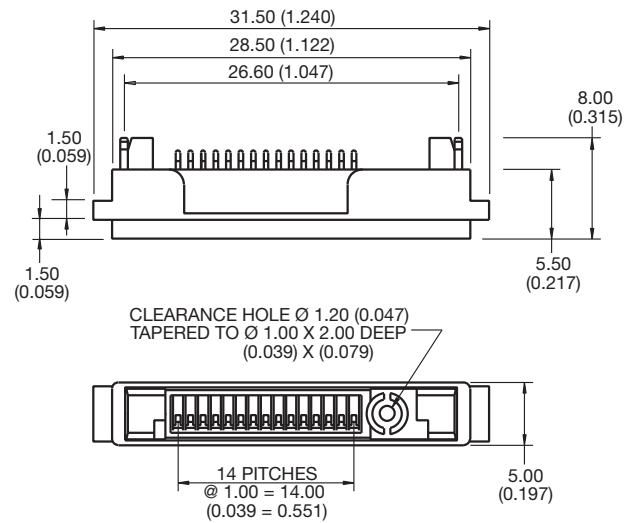

SMT PAD LAYOUT

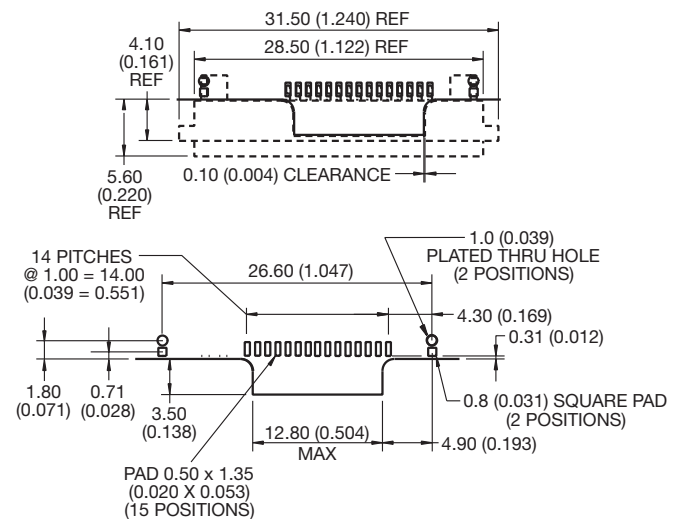
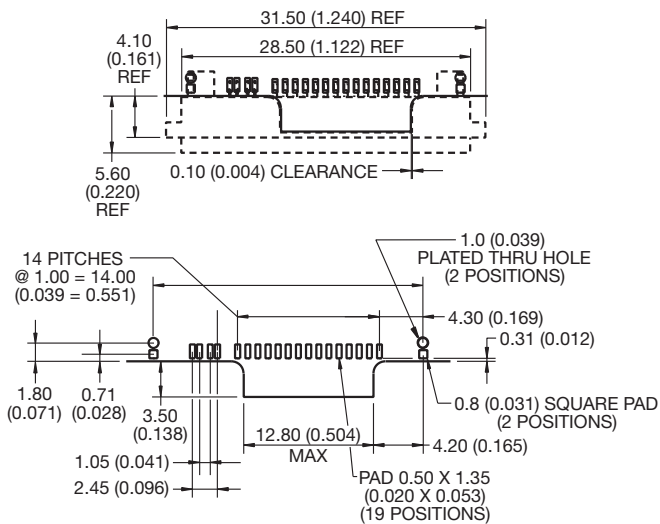

Cover Kit

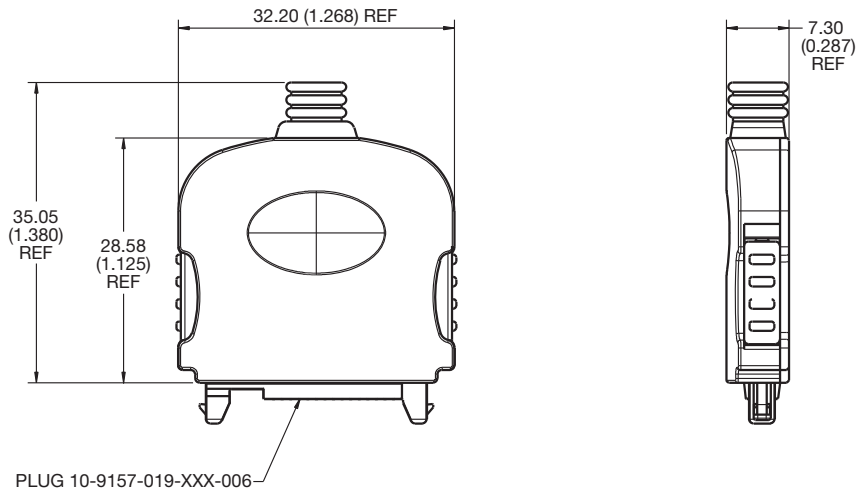

HOW TO ORDER

Plug Options – Example

<u>10</u>	<u>9157</u>	<u>015</u>	<u>000</u>	<u>006</u>
Prefix 10 = Plug 58 = Special	Series	No of Ways 15 = 015	RF Coax Option 000 = No RF Coax 001 = With RF Coax	Contact Type 006 = Solder Wire 007 = SMT

Socket Options – Example

<u>20</u>	<u>9157</u>	<u>015</u>	<u>000</u>	<u>006</u>
Prefix 20 = Socket 58 = Special	Series	No of Ways 15 = 015	RF Coax Option 000 = No RF Coax 001 = With RF Coax	Contact Type 006 = SMT

Cover Options – Example * Parts supplied in kit form

<u>30</u>	<u>9157</u>	<u>9700</u>	<u>00</u>	<u>000</u>
Prefix 30 = Sub Assembly 58 = Special	Series	Cover Version 9700 = Screw/Press-fit Version	Standard	Grommet Variation 000 = No Grommet 035 = to suit ϕ 3.50 cable 050 = to suit ϕ 5.00 cable

Patent: 2276285
5540599

Note: Application tooling to terminate coax cable 06-9157-7116-01-000.

9157 MOBO[®] 19 Way I/O Connector



GENERAL DESCRIPTION

Based on our standard 15 way 9157 I/O family, AVX has now released a family 19 way devices. This range includes a SMT 90 degree plug, a wire socket version that is used with the standard 9157 cover and a SMT socket for charging applications.

Options with the 90 degree SMT socket include the sealing of the connector contacts and the connector to the housing up to IP67. There is also an option to have an EMLB (early mate, late break) on pins 1 and 19.

To achieve the seal to the device housing, it may be necessary to customize the device housing design.

On the SMT 90 degree version, we also have the capability of an integrated DC jack, enabling both the DC jack and the 19 way cover to be plugged in at the same time.

AVAILABLE DEVICES:

- | | |
|-----------------------------|----------------------------------|
| 10 9157 019 000 006 | Plug wire version |
| 10 9157 019 000 007 | SMT charging version |
| 20 9157 019 000 006 | 90 degree SMT socket |
| 30 9157 97 XX 00 000 | Cover options see page 36 |

Cover Kit

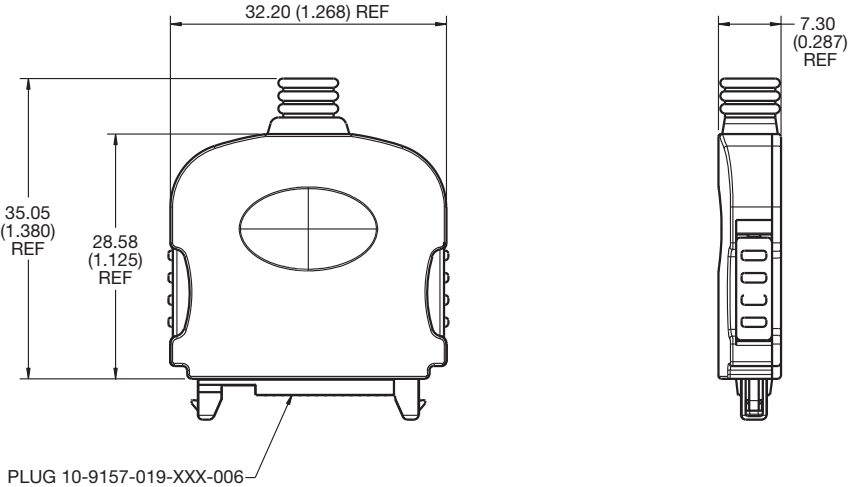

9157 MOBO[®] 19 Way I/O Connector



Plug Wire

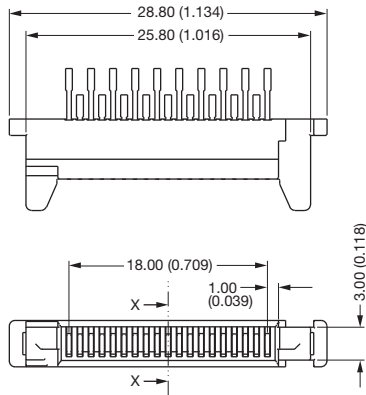

SMT Plug

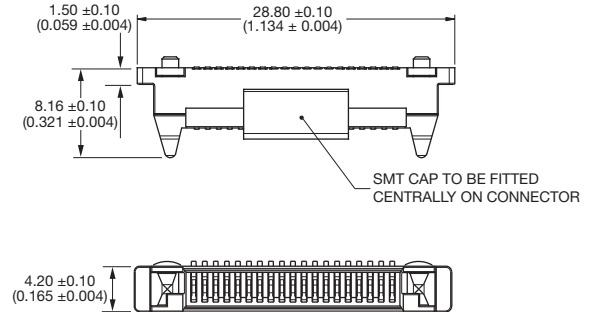

SMT Socket

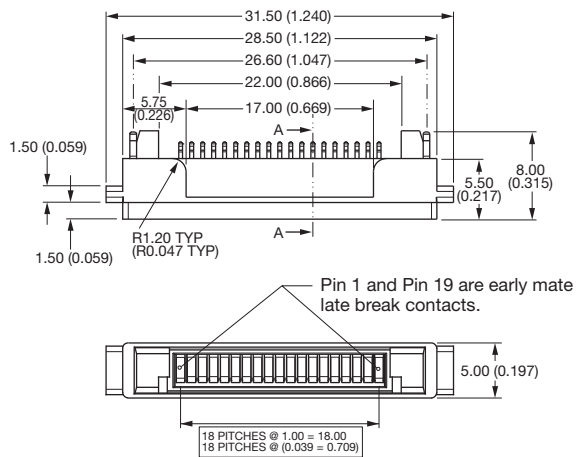

SMT Plug (Suggested PCB Layout)

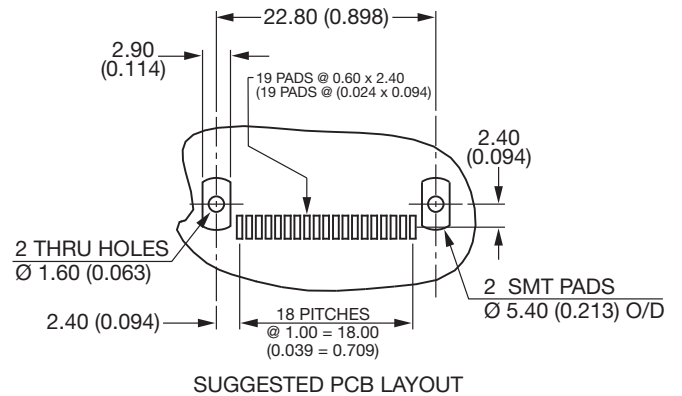

SMT Socket (Suggested PCB Layout)

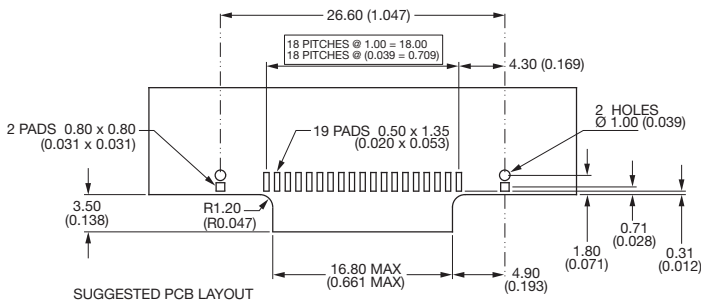



GENERAL DESCRIPTION

An I/O interconnect system designed for portable equipment.

AVX offers this plug and socket reduced size system as a standard product. The fixed SMT socket is designed to be mounted on a PCB and housed within a portable device. The plug is designed for cable termination with options of single and double sided contacts and customizing the overmold cover or parts can be supplied as connector only for sub contract termination. The socket connector houses 16 contacts in two rows on 1.25mm pitch with a rating of 1 amp per contact. Both connectors are RoHS compliant.

APPLICATIONS

Suitable applications include:

- Cellular Phones
- Handheld Devices
- Industrial Modules
- Medical Electronics

KEY FEATURES AND BENEFITS

- No latching is required due to the click design of the contacts.
- Optional customization of the overmold cover.
- Options of single row (8 way) or dual row (16 way) plug connector.
- Compact size to optimize PCB real estate.
- Metal outer cover provides integrated PCB location and solder tab.
- Positive alignment and orientation of the plug and socket.
- 5K mating cycles and 1 amp rated.



9257 Reduced Size I/O Connector



Single Sided 8 Way I/O Plug Connector

Dual Sided 16 Way I/O Plug Connector

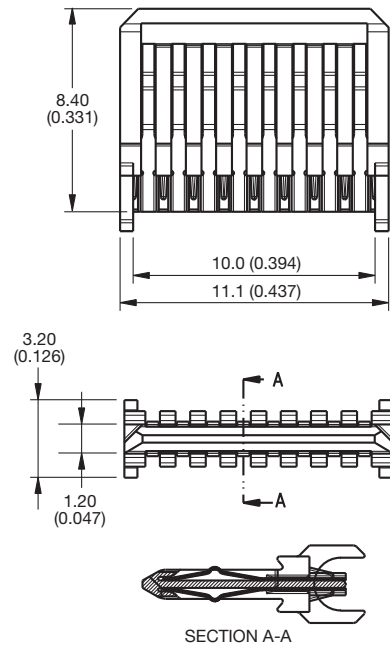
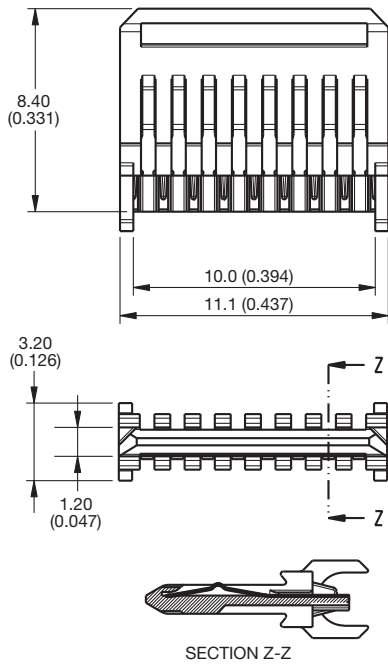

Suggested Overmolding for Plug Connector

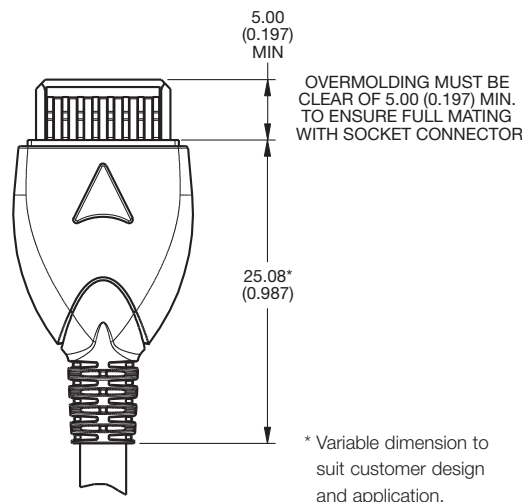

HOW TO ORDER

10

Prefix
10 = Plug Connector

9257

Series

016

No of Ways
016 = 16 way dual sided
008 = 8 way single sided

001

Contact
001 = Solder Bucket

003

Plating Option
003 = 0.8µm Selective Gold,
Tin Tail

Notes:

1. All dimensions are for reference only unless toleranced.
2. For full product specification refer to AVX spec 201-01-089.
3. Parts packed in tube with 50 parts per tube.



16 Position I/O Socket

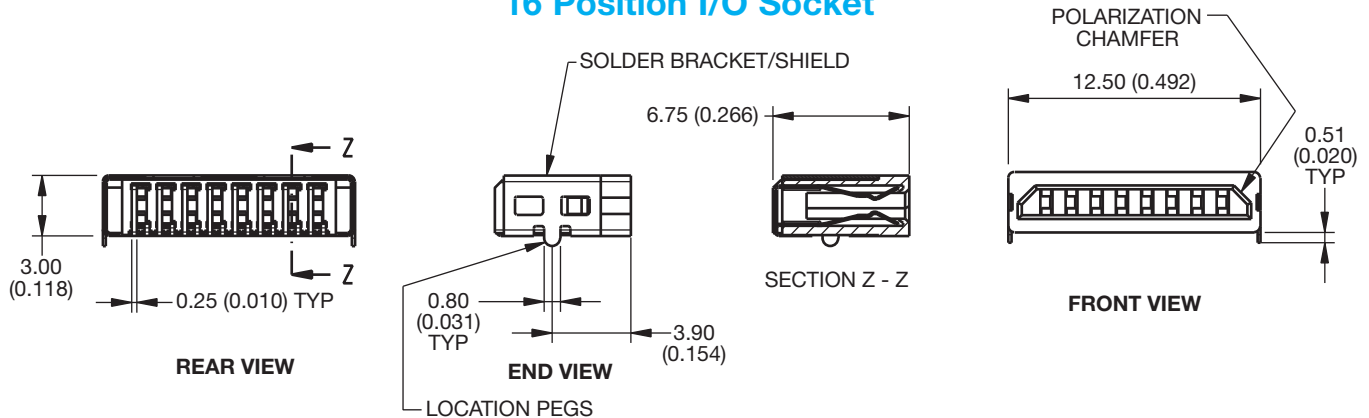

PCB Layout

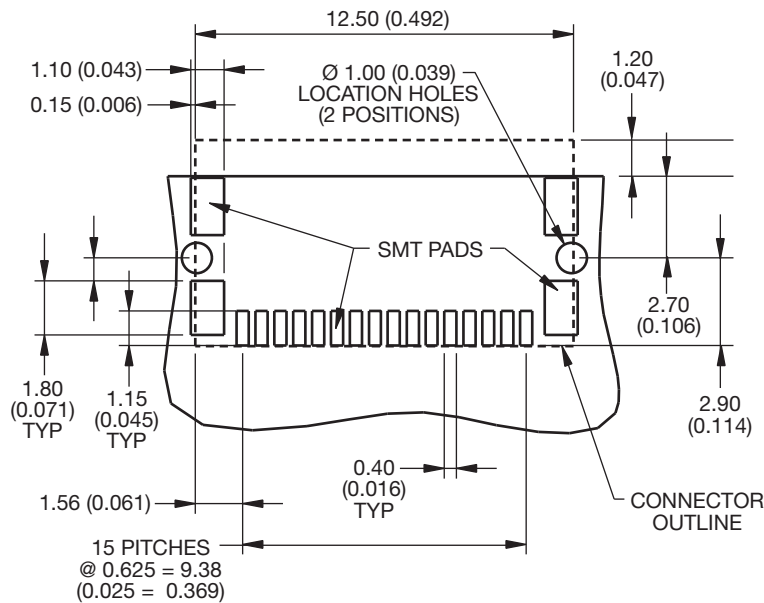

HOW TO ORDER

20

Prefix

20 = Socket Connector

9257

Series

016

No of Ways
 16 = 016

001

Contacts

001 = SMT Termination

01

Solder Bracket

01 = Solder Bracket with location pegs

3

Plating Option

3 = 0.8µm Selective Gold, Tin Tail

Packing Details	
Reel Qty.	1100
Pack Qty.	5500

Notes:

1. 16 Way I/O Socket.
2. For full product specification refer to AVX spec 201-01-089.
3. General tolerance ± 0.20 (0.008) unless otherwise stated.
4. SMT feet within 0.13 (0.005) coplanarity.

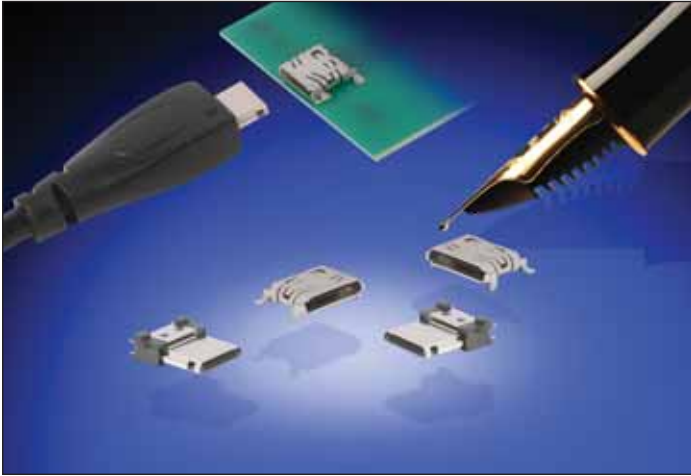

GENERAL DESCRIPTION

AVX offers the 12 way mini I/O connector as a standard product. The fixed SMT socket is designed to be mounted on a PCB and housed within a portable device. The plug is designed for cable termination with options of single and double sided contacts. Parts can be supplied as connectors only for sub contract termination, or with a custom overmold cover. The socket connector houses 12 contacts in a single row on 0.50mm pitch.

APPLICATIONS

- Medical Electronics
- Cellular Phones
- Industrial Modules
- Hand Held Devices

KEY FEATURES AND BENEFITS

- No latching required due to the click design of the contacts.
- Optional customization of the overmold cover.
- Compact size to optimize PCB real estate.
- Metal outer cover provides integrated PCB location and solder tab.
- Positive alignment and orientation of the plug and socket.

9257 STANDARD 12 WAY MINI I/O PLUG

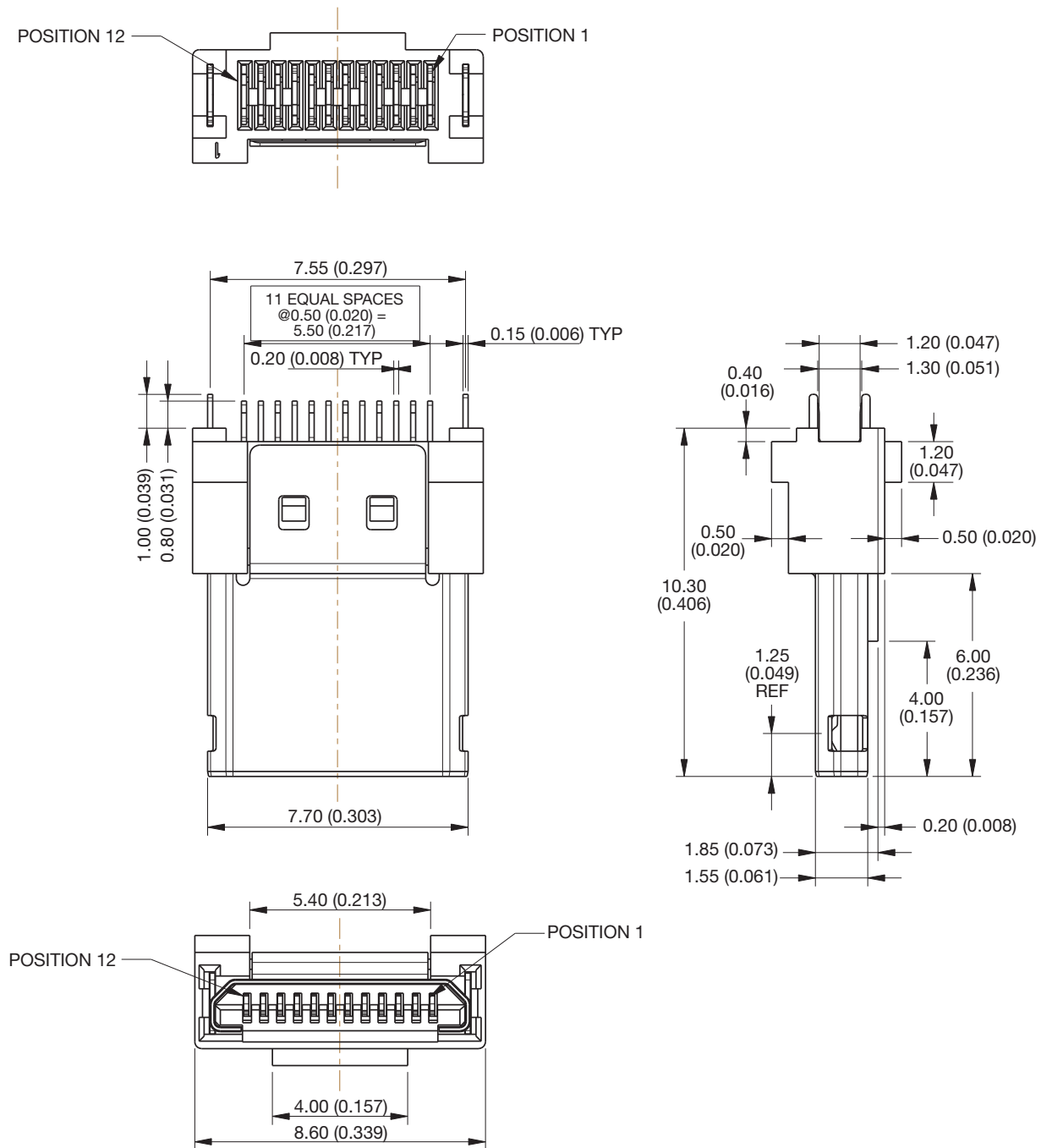

HOW TO ORDER

10	9257	012	101	006
Prefix	Series	No of Ways	Contacts	Plating Option
10 = Plug Connector		12 = 012	101 = Solder Tail	006 = 0.25µm Gold over Nickel

SUGGESTED OVERMOLDING FOR PLUG CONNECTOR

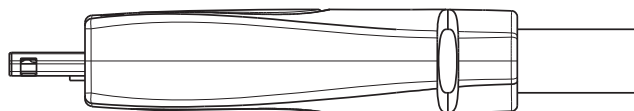
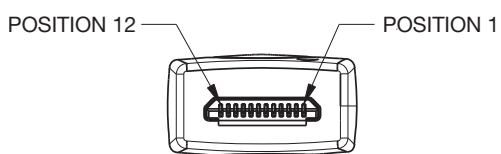
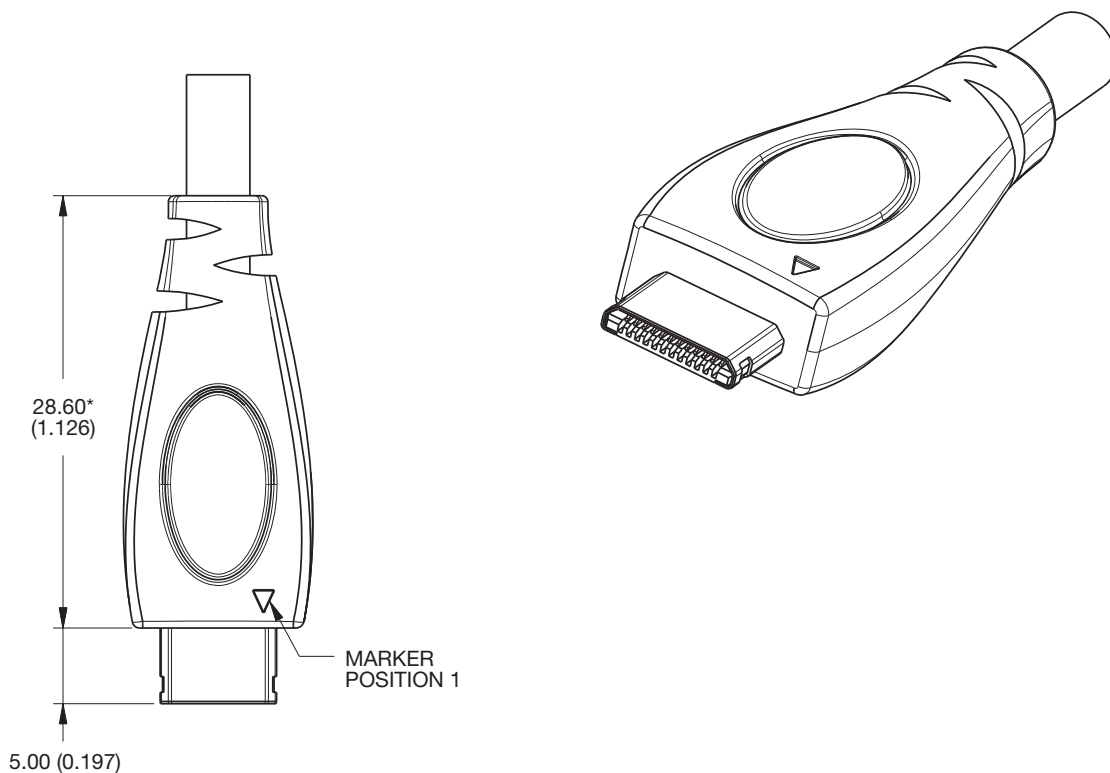

DIMENSION MARKED WITH A * ARE
VARIABLE DIMENSION TO SUIT
CUSTOMER DESIGN AND APPLICATION

9257 STANDARD 12 WAY MINI I/O SOCKET

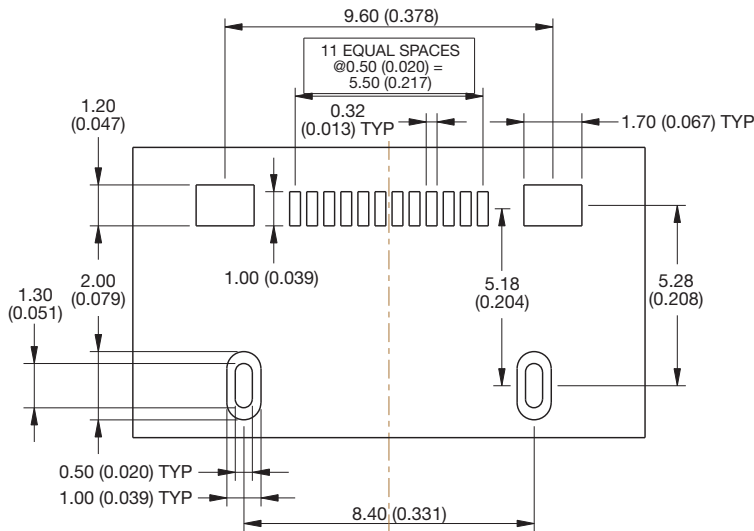
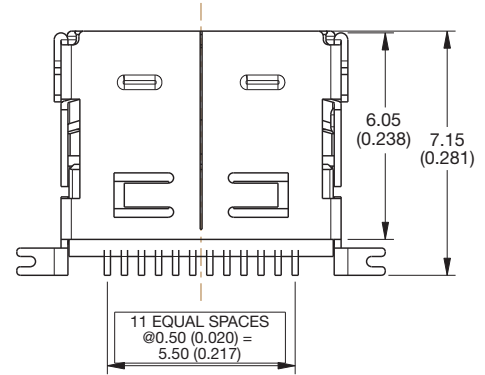
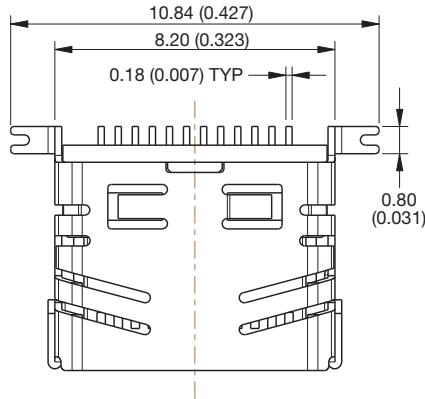

SUGGESTED PCB LAYOUT

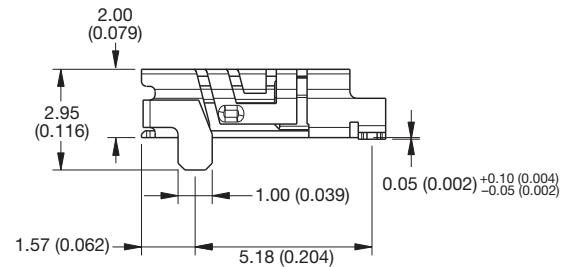
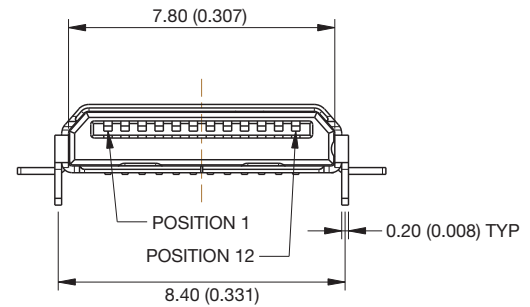

HOW TO ORDER

20

Prefix

20 = Socket Connector

9257

Series

012

No of Ways

12 = 012

101

Contacts

101 = SMT Termination

01

Solder Bracket

01 = Solder Bracket with location pegs

6

Plating Option

6 = 0.25µm Gold over Nickel

AMERICAS

AVX Greenville, SC
Tel: 864-967-2150

AVX Northwest, WA
Tel: 360-699-8746

AVX Midwest, IN
Tel: 317-861-9184

AVX Mid/Pacific, CA
Tel: 408-988-4900

AVX Northeast, MA
Tel: 617-479-0345

AVX Southwest, CA
Tel: 949-859-9509

AVX Canada
Tel: 905-238-3151

AVX South America
Tel: +55-11-4688-1960

EUROPE

AVX Limited, England
Tel: +44-1276-697000

AVX S.A.S., France
Tel: +33-1-69-18-46-00

AVX GmbH, Germany
Tel: +49-0811-95949-0

AVX SRL, Italy
Tel: +39-02-614-571

AVX Czech Republic
Tel: +420-57-57-57-521

AVX/ELCO UK
Tel: +44-1638-675000

ELCO Europe GmbH
Tel: +49-2741-299-0

AVX S.A., Spain
Tel: +34-91-63-97-197

AVX Benelux
Tel: +31-187-489-337

ASIA-PACIFIC

**AVX/Kyocera (S) Pte Ltd.,
Singapore**
Tel: +65-6286-7555

**AVX/Kyocera, Asia, Ltd.,
Hong Kong**
Tel: +852-2363-3303

**AVX/Kyocera Yuhan Hoesa,
South Korea**
Tel: +82-2785-6504

**AVX/Kyocera HK Ltd.,
Taiwan**
Tel: +886-2-2656-0258

**AVX/Kyocera (M) Sdn Bhd,
Malaysia**
Tel: +60-4228-1190

**AVX/Kyocera International
Trading Co. Ltd.,
Shanghai**
Tel: +86-21-3255 1933

**AVX/Kyocera Asia Ltd.,
Shenzen**
Tel: +86-755-3336-0615

**AVX/Kyocera International
Trading Co. Ltd.,
Beijing**
Tel: +86-10-6588-3528

**AVX/Kyocera India
Liaison Office**
Tel: +91-80-6450-0715

ASIA-KED (KYOCERA Electronic Devices)

KED Hong Kong Ltd.
Tel: +852-2305-1080/1223

**KED Hong Kong Ltd.
Shenzen**
Tel: +86-755-3398-9600

**KED Company Ltd.
Shanghai**
Tel: +86-21-3255-1833

**KED Hong Kong Ltd.
Beijing**
Tel: +86-10-5869-4655

KED Taiwan Ltd.
Tel: +886-2-2950-0268

**KED Korea Yuhan Hoesa,
South Korea**
Tel: +82-2-783-3604/6126

**KED (S) Pte Ltd.
Singapore**
Tel: +65-6509-0328

**Kyocera Corporation
Japan**
Tel: +81-75-604-3449

Contact:





Стандарт Электрон Связь

Мы молодая и активно развивающаяся компания в области поставок электронных компонентов. Мы поставляем электронные компоненты отечественного и импортного производства напрямую от производителей и с крупнейших складов мира.

Благодаря сотрудничеству с мировыми поставщиками мы осуществляем комплексные и плановые поставки широчайшего спектра электронных компонентов.

Собственная эффективная логистика и склад в обеспечивает надежную поставку продукции в точно указанные сроки по всей России.

Мы осуществляем техническую поддержку нашим клиентам и предпродажную проверку качества продукции. На все поставляемые продукты мы предоставляем гарантию .

Осуществляем поставки продукции под контролем ВП МО РФ на предприятия военно-промышленного комплекса России , а также работаем в рамках 275 ФЗ с открытием отдельных счетов в уполномоченном банке. Система менеджмента качества компании соответствует требованиям ГОСТ ISO 9001.

Минимальные сроки поставки, гибкие цены, неограниченный ассортимент и индивидуальный подход к клиентам являются основой для выстраивания долгосрочного и эффективного сотрудничества с предприятиями радиоэлектронной промышленности, предприятиями ВПК и научно-исследовательскими институтами России.

С нами вы становитесь еще успешнее!

Наши контакты:

Телефон: +7 812 627 14 35

Электронная почта: sales@st-electron.ru

Адрес: 198099, Санкт-Петербург,
Промышленная ул, дом № 19, литера Н,
помещение 100-Н Офис 331