



**IEC62055-31 UC3 compliant  
(short current 3,000 A)  
1 Form A 120A power  
latching relays**

## DZ RELAYS (ADZ)

New



Horizontal terminal type

New



Vertical terminal type

**RoHS compliant**

### FEATURES

- IEC62055-31 UC3 compliant (short current 3,000 A)**
- High switching capacity**  
120 A 250 VAC (Resistive load)
- Twin contacts for low temperature rise**
- Low operating power**  
1 coil latching: 1.4 W  
2 coil latching: 2.8 W
- Small size: W: 41 x L: 35 x H: 22 mm**  
W: 1.614 x L: 1.378 x H: .866 inch

### TYPICAL APPLICATIONS

- Smart meters
- Charge station
- Other industrial equipment

Protective construction: Dust cover type

### ORDERING INFORMATION

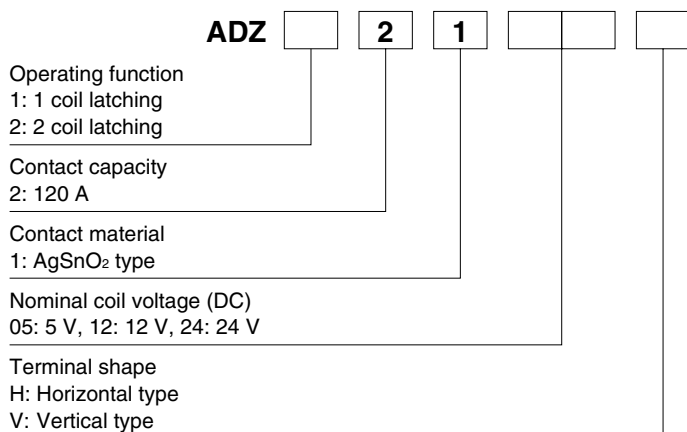

### TYPES

Contact arrangement	Nominal coil voltage	Part No.			
		1 coil latching		2 coil latching	
		Horizontal terminal type	Vertical terminal type	Horizontal terminal type	Vertical terminal type
1 Form A	5 V DC	ADZ12105H	ADZ12105V	ADZ22105H	ADZ22105V
	12 V DC	ADZ12112H	ADZ12112V	ADZ22112H	ADZ22112V
	24 V DC	ADZ12124H	ADZ12124V	ADZ22124H	ADZ22124V

Standard packing: Carton: 20 pcs.; Case: 100 pcs.

## RATING

### 1. Coil data

#### 1) 1 coil latching

Nominal coil voltage	Set voltage (at 20°C 68°F)	Reset voltage (at 20°C 68°F)	Nominal operating current [±10%] (at 20°C 68°F)	Coil resistance [±10%] (at 20°C 68°F)	Nominal operating power	Max. applied voltage (at 20°C 68°F)
5 V DC	*70%V or less of nominal voltage (Initial)	*70%V or less of nominal voltage (Initial)	280.0 mA	17.9 Ω	1,400 mW	130%V of nominal voltage
12 V DC			116.7 mA	102.9 Ω		
24 V DC			58.3 mA	411.4 Ω		

#### 2) 2 coil latching

Nominal coil voltage	Set voltage (at 20°C 68°F)	Reset voltage (at 20°C 68°F)	Nominal operating current [±10%] (at 20°C 68°F)	Coil resistance [±10%] (at 20°C 68°F)	Nominal operating power	Max. applied voltage (at 20°C 68°F)
5 V DC	*70%V or less of nominal voltage (Initial)	*70%V or less of nominal voltage (Initial)	560.0 mA	8.9 Ω	2,800 mW	130%V of nominal voltage
12 V DC			233.3 mA	51.4 Ω		
24 V DC			116.7 mA	205.7 Ω		

\*Pulse drive (JIS C 5442-1996)

## 2. Specifications

Characteristics	Item	Specifications	
		1 coil latching	2 coil latching
Contact	Arrangement	1 Form A	
	Contact voltage drop	Max. 0.12V (at 120A), Max. 0.10V (at 20A)	
	Contact material	AgSnO <sub>2</sub> type	
Rating	Nominal switching capacity (resistive load)	120 A 250 V AC	
	Max. switching power (resistive load)	30,000 VA	
	Max. switching voltage	276 V AC	
	Max. switching current	120 A AC	
	Nominal operating power	1,400 mW (1 coil latching)	2,800 mW (2 coil latching)
	Min. switching capacity (Reference value)*1	100 mA 24 V DC	
Electrical characteristics	Insulation resistance (Initial)	Min. 1,000 MΩ (at 500 V DC) Measurement at same location as "Breakdown voltage" section.	
	Breakdown voltage (Initial)	Between open contacts	2,000 Vrms for 1min. (Detection current: 10 mA)
		Between contact and coil	4,000 Vrms for 1min. (Detection current: 10 mA)
	Overcurrent resistance (Initial)	Min. 3,000 A (Half-wave pulse of sine wave: 10 ms)*4	
	Surge breakdown voltage*2 (Between contact and coil)	12,000 V (Initial)	
	Set time (at 20°C 68°F)	Max. 20 ms (Nominal voltage applied to the coil, excluding contact bounce time)	
Reset time (at 20°C 68°F)	Max. 20 ms (Nominal voltage applied to the coil, excluding contact bounce time)		
Mechanical characteristics	Shock resistance	Functional	300 m/s <sup>2</sup> (Half-wave pulse of sine wave: 11 ms; detection time: 10 μs)
		Destructive	1,000 m/s <sup>2</sup> (Half-wave pulse of sine wave: 6 ms)
	Vibration resistance	Functional	10 to 55 Hz at double amplitude of 1.5 mm (Detection time: 10 μs)
		Destructive	10 to 55 Hz at double amplitude of 2.0 mm
Expected life*3	Mechanical	Min. 10 <sup>5</sup> (at 180 times/min.)	
	Electrical	Resistive load	120 A 250 V AC Min. 10 <sup>3</sup> (operating frequency: ON : OFF = 10 s : 20 s)
		UC3 class	100 A 276 V AC Min. 10 <sup>4</sup> (cosφ = 1.0 : 5,000, cosφ = 0.5 : 5,000, operating frequency: ON : OFF = 10 s : 20 s)*5
Conditions	Conditions for operation, transport and storage*3	Ambient temperature: -40°C to +85°C -40°F to +185°F Humidity: 5 to 85% R.H. (Not freezing and condensing at low temperature)	
Unit weight		Approx. 75 g 2.65 oz	

Notes: \*1. This value can change due to the switching frequency, environmental conditions, and desired reliability level, therefore it is recommended to check this with the actual load.

\*2. Wave is standard shock voltage of ±1.2 × 50 μs according to JEC-212-1981

\*3. The upper limit of the ambient temperature is the maximum temperature that can satisfy the coil temperature rise value. Refer to Usage, operation, transport and storage conditions in NOTES.

\*4. IEC62055-31 UC3 compliant

\*5. Based on IEC62055-31 UC3, inductive load test was conducted after resistive load test, and expressed as total.



## NOTES

**1. For cautions for use, please read "GENERAL APPLICATION GUIDELINES" on page B-1.**

### 2. Operation, transport and storage

Following is the conditions of ambient temperature, humidity and air pressure in case of operation, transport and storage.

1) Ambient temperature:  $-40$  to  $+85^{\circ}\text{C}$   
 $-40$  to  $+185^{\circ}\text{F}$  (Max. 100A over  $70^{\circ}\text{C}$   
 $158^{\circ}\text{F}$ )

2) Humidity: 5 to 85%RH (Not freezing and condensing)

In addition the humidity range depends on temperature.

The allowable ranges are as follows;

3) Air pressure: 86 to 106kPa

Allowable range of ambient temperature and humidity for operation, transport and storage.

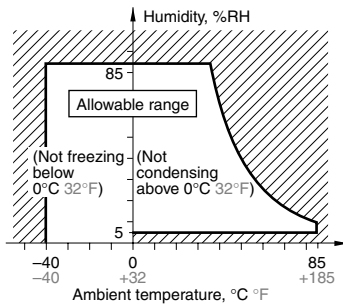

### 4) Condensing

Condensing occurs when the relay is exposed to sudden temperature change in a high-temperature, high-humidity atmosphere. This may cause some troubles like insulation failure.

### 5) Freezing

At temperature below  $0^{\circ}\text{C}$   $32^{\circ}\text{F}$ , moisture may freeze. This may lead to some troubles like sticking of the moving portion of the relay or delayed operation.

### 6) Low-temperature, low-humidity atmosphere

If the relay is exposed to a low-temperature, low-humidity atmosphere for a long time, its plastic parts may become brittle and fragile.

### 3. Soldering and cleaning

1) In case of soldering, following conditions should be observed.

Manual soldering:

Max.  $260^{\circ}\text{C}$   $500^{\circ}\text{F}$  (solder temperature) within 10s (soldering time)

Max.  $350^{\circ}\text{C}$   $662^{\circ}\text{F}$  (solder temperature) within 3s (soldering time)

\* Furthermore, because the type of PC board used and other factors may influence the relays, test that the relays function properly on the actual PC board on which they are mounted.

2) Since this is not a sealed type relay, do not clean it as is. Also, be careful not to allow flux to overflow above the PC board or enter the inside of the relay.

### 4. Terminal installation condition

Installation torque for contact terminal

(M4): 1.2 to 1.4 N·m

### 5. Cautions for use

1) This relay is designed to dust cover type. Malfunction and contact failure may result if small insects get inside the relay.

2) Installation of M4 securing screw for contact terminal

Do not apply excessive pressure on the terminals. This could adversely affect relay performance. Use a washer in order to prevent deformation.

Keep the installation torque to within 1.2 to 1.4 N·m (12 to 14 kgf·cm).

Also, use a spring washer to prevent it from loosening.

3) Through hole on the relay is for temporary fixing use. Do not fix relay through hole only.

# Mouser Electronics

Authorized Distributor

Click to View Pricing, Inventory, Delivery & Lifecycle Information:

## Panasonic:

[ADZ12124V](#) [ADZ12124H](#) [ADZ12112V](#) [ADZ12112H](#) [ADZ12105H](#) [ADZ12105V](#) [ADZ22105V](#) [ADZ22105H](#)  
[ADZ22124V](#) [ADZ22124H](#) [ADZ22112V](#) [ADZ22112H](#)



## Стандарт Электрон Связь

Мы молодая и активно развивающаяся компания в области поставок электронных компонентов. Мы поставляем электронные компоненты отечественного и импортного производства напрямую от производителей и с крупнейших складов мира.

Благодаря сотрудничеству с мировыми поставщиками мы осуществляем комплексные и плановые поставки широчайшего спектра электронных компонентов.

Собственная эффективная логистика и склад в обеспечивает надежную поставку продукции в точно указанные сроки по всей России.

Мы осуществляем техническую поддержку нашим клиентам и предпродажную проверку качества продукции. На все поставляемые продукты мы предоставляем гарантию .

Осуществляем поставки продукции под контролем ВП МО РФ на предприятия военно-промышленного комплекса России , а также работаем в рамках 275 ФЗ с открытием отдельных счетов в уполномоченном банке. Система менеджмента качества компании соответствует требованиям ГОСТ ISO 9001.

Минимальные сроки поставки, гибкие цены, неограниченный ассортимент и индивидуальный подход к клиентам являются основой для выстраивания долгосрочного и эффективного сотрудничества с предприятиями радиоэлектронной промышленности, предприятиями ВПК и научно-исследовательскими институтами России.

С нами вы становитесь еще успешнее!

### Наши контакты:

**Телефон:** +7 812 627 14 35

**Электронная почта:** [sales@st-electron.ru](mailto:sales@st-electron.ru)

**Адрес:** 198099, Санкт-Петербург,  
Промышленная ул, дом № 19, литера Н,  
помещение 100-Н Офис 331