

Temperature measuring transducer - MACX MCR-SL-TC-I-NC - 2924346

Please be informed that the data shown in this PDF Document is generated from our Online Catalog. Please find the complete data in the user's documentation. Our General Terms of Use for Downloads are valid (<http://phoenixcontact.com/download>)



Temperature transducer, converts signals from thermocouples and linear mV sources into 0/4-20 mA signals. Freely programmable, 3-way electrical isolation, custom-configured.

Product Features

- Input for thermocouples and mV sources
- Power supply possible via DIN rail connector
- Installation in zone 2, protection type "n" (EN 60079-15) permitted
- 0 ... 20 mA or 4 ... 20 mA output
- Programming during operation and also voltage-free using IFS-USB-PROG-ADAPTER programming adapter
- Status indicator for supply voltage, cable, sensor, and module errors
- 3-way electrical isolation
- Configuration via software (FDT/DTM): sensor type, connection technology, measuring range, measuring unit, filter, alarm signal, and output range



Key Commercial Data

Packing unit	1 pc
Weight per Piece (excluding packing)	140.0 g
Custom tariff number	85437090
Country of origin	Germany

Technical data

Note

Utilization restriction	EMC: class A product, see manufacturer's declaration in the download area
-------------------------	---

Dimensions

Width	12.5 mm
-------	---------

Temperature measuring transducer - MACX MCR-SL-TC-I-NC - 2924346

Technical data

Dimensions

Height	99 mm
Depth	114.5 mm

Ambient conditions

Ambient temperature (operation)	-20 °C ... 60 °C (Any mounting position)
Ambient temperature (storage/transport)	-40 °C ... 80 °C
Maximum altitude	≤ 2000 m
Permissible humidity (operation)	5 % ... 95 % (non-condensing)
Noise immunity	EN 61000-6-2 When being exposed to interference, there may be minimal deviations.
Degree of protection	IP20

Input data

Sensor types that can be used (TC)	E, J, K, N as per IEC / EN 60584, L as per DIN 43760
Temperature measuring range	-250 °C ... 1372 °C (Range depending on the sensor type)
Input signal range	-20 mV ... 70 mV
Measuring range span	Min. 50 K for thermocouples, 3 mV for mV sources

Output data

Signal output	Current output
Current output signal	0 mA ... 20 mA
	4 mA ... 20 mA
Load/output load current output	max. 500 Ω
Output ripple (current)	< 50 μA _{pp}
Behavior in the event of a sensor error	As per NE 43 or can be freely defined

Power supply

Nominal supply voltage	24 V DC
Supply voltage range	19.2 V DC ... 30 V DC (24 V DC -20%...+25%)
Max. current consumption	< 40 mA (24 V DC)
Power consumption	< 1 W

Connection data

Conductor cross section solid min.	0.2 mm ²
Conductor cross section solid max.	2.5 mm ²
Conductor cross section flexible min.	0.2 mm ²
Conductor cross section flexible max.	2.5 mm ²
Conductor cross section AWG min.	24
Conductor cross section AWG max.	14
Stripping length	7 mm

Temperature measuring transducer - MACX MCR-SL-TC-I-NC - 2924346

Technical data

Connection data

Screw thread	M3
Connection method	Screw connection
Tightening torque, min	0.5 Nm
Tightening torque max	0.6 Nm

General

No. of channels	1
Temperature coefficient, typical	0.01 %/K
Typical cold point errors	± 1 K
Step response (0–99%)	typ. 700 ms
	≤ 1100 ms
Alignment zero	± 5 %
Alignment span	± 5 %
Status display	Green LED (supply voltage, PWR)
	Red LED, flashing (line, sensor error, ERR)
	Red LED (module error, ERR)
Flammability rating according to UL 94	V0
Degree of pollution	2
Overvoltage category	II
Electromagnetic compatibility	Conformance with EMC directive
Emitted interference	EN 61000-6-4
Housing material	PA 66-FR
Color	green
Designation	Input/output/power supply
Electrical isolation	300 V _{rms} (Rated insulation voltage (overvoltage category II; degree of pollution 2, safe isolation as per EN 61010-1))
	2.5 kV (50 Hz, 1 min., test voltage)
Designation	Input/output
Electrical isolation	375 V (Peak value in accordance with EN 60079-11)
Designation	Input/power supply
Electrical isolation	375 V (Peak value in accordance with EN 60079-11)
Conformance	CE-compliant, additionally EN 61326-1
ATEX	# II 3G Ex nA ic IIC T4 Gc X
UL, USA / Canada	UL 508 Listed
	UL 61010 Listed
	Class I, Div. 2, Groups A, B, C, D T4
	Class I, Zone 2, Group IIC T4
GL	C, EMC1

Temperature measuring transducer - MACX MCR-SL-TC-I-NC - 2924346

Technical data

Standards and Regulations

Electromagnetic compatibility	Conformance with EMC directive
Noise emission	EN 61000-6-4
Flammability rating according to UL 94	V0
Conformance	CE-compliant, additionally EN 61326-1
ATEX	# II 3G Ex nA ic IIC T4 Gc X
UL, USA / Canada	UL 508 Listed
	UL 61010 Listed
	Class I, Div. 2, Groups A, B, C, D T4
	Class I, Zone 2, Group IIC T4
GL	C, EMC1

Classifications

eCl@ss

eCl@ss 4.0	27200206
eCl@ss 4.1	27200206
eCl@ss 5.0	27200206
eCl@ss 5.1	27210121
eCl@ss 6.0	27200206
eCl@ss 7.0	27200206
eCl@ss 8.0	27371503

ETIM

ETIM 2.0	EC001446
ETIM 3.0	EC001446
ETIM 4.0	EC001446
ETIM 5.0	EC002568

UNSPSC

UNSPSC 6.01	30211506
UNSPSC 7.0901	39121008
UNSPSC 11	39121008
UNSPSC 12.01	39121008
UNSPSC 13.2	39121008

Approvals

Approvals

Temperature measuring transducer - MACX MCR-SL-TC-I-NC - 2924346

Approvals

Approvals

UL Listed / cUL Listed / cULus Listed

Ex Approvals

UL Listed / cUL Listed / cULus Listed

Approvals submitted

Approval details

UL Listed

cUL Listed

cULus Listed

Drawings

Dimensional drawing

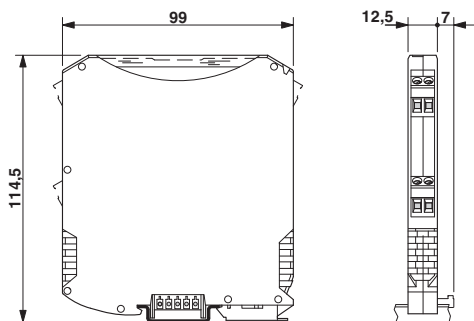

Block diagram

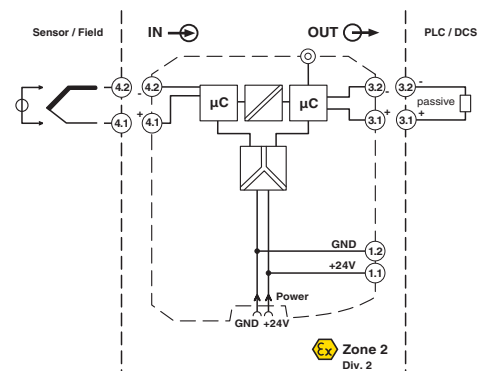



**Стандарт
Электрон
Связь**

Мы молодая и активно развивающаяся компания в области поставок электронных компонентов. Мы поставляем электронные компоненты отечественного и импортного производства напрямую от производителей и с крупнейших складов мира.

Благодаря сотрудничеству с мировыми поставщиками мы осуществляем комплексные и плановые поставки широчайшего спектра электронных компонентов.

Собственная эффективная логистика и склад в обеспечивает надежную поставку продукции в точно указанные сроки по всей России.

Мы осуществляем техническую поддержку нашим клиентам и предпродажную проверку качества продукции. На все поставляемые продукты мы предоставляем гарантию .

Осуществляем поставки продукции под контролем ВП МО РФ на предприятия военно-промышленного комплекса России , а также работаем в рамках 275 ФЗ с открытием отдельных счетов в уполномоченном банке. Система менеджмента качества компании соответствует требованиям ГОСТ ISO 9001.

Минимальные сроки поставки, гибкие цены, неограниченный ассортимент и индивидуальный подход к клиентам являются основой для выстраивания долгосрочного и эффективного сотрудничества с предприятиями радиоэлектронной промышленности, предприятиями ВПК и научно-исследовательскими институтами России.

С нами вы становитесь еще успешнее!

Наши контакты:

Телефон: +7 812 627 14 35

Электронная почта: sales@st-electron.ru

Адрес: 198099, Санкт-Петербург,
Промышленная ул, дом № 19, литера Н,
помещение 100-Н Офис 331