



KSZ8091RNA/KSZ8091RND

10Base-T/100Base-TX Physical Layer Transceiver

Revision 1.2

General Description

The KSZ8091RNA is a single-supply 10Base-T/100Base-TX Ethernet physical-layer transceiver for transmission and reception of data over standard CAT-5 unshielded twisted pair (UTP) cable.

The KSZ8091RNA is a highly-integrated PHY solution. It reduces board cost and simplifies board layout by using on-chip termination resistors for the differential pairs and by integrating a low-noise regulator to supply the 1.2V core, and by offering a flexible 1.8/2.5/3.3V digital I/O interface.

The KSZ8091RNA offers the Reduced Media Independent Interface (RMII) for direct connection with RMII-compliant Ethernet MAC processors and switches.

As the power-up default, the KSZ8091RNA uses a 25MHz crystal to generate all required clocks, including the 50MHz RMII reference clock output for the MAC. The KSZ8091RND takes in the 50MHz RMII reference clock as the power-up default.

Energy Efficient Ethernet (EEE) provides further power saving during idle traffic periods and Wake-On-LAN (WOL) provides a mechanism for the KSZ8091RNA to wake up a system that is in standby power mode.

The KSZ8091RNA and KSZ8091RND are available in 24-pin, lead-free QFN packages (see [Ordering Information](#)).

Datasheets and support documentation are available on website at: www.micrel.com.

Features

- Single-chip 10Base-T/100Base-TX IEEE 802.3 compliant Ethernet transceiver
- RMII v1.2 interface support with a 50MHz reference clock output to MAC, and an option to input a 50MHz reference clock
- RMII back-to-back mode support for a 100Mbps copper repeater
- MDC/MDIO management interface for PHY register configuration
- Programmable interrupt output
- LED outputs for link and activity status indication
- On-chip termination resistors for the differential pairs
- Baseline wander correction
- HP Auto MDI/MDI-X to reliably detect and correct straight-through and crossover cable connections with disable and enable option
- Auto-Negotiation to automatically select the highest link-up speed (10/100Mbps) and duplex (half/full)
- Energy Efficient Ethernet (EEE) support with low-power idle (LPI) mode for 100Base TX and transmit amplitude reduction with 10Base-Te option
- Wake-On-LAN (WOL) support with either magic packet, link status change, or robust custom-packet detection
- LinkMD[®] TDR-based cable diagnostics to identify faulty copper cabling
- HBM ESD rating (6kV)

Functional Diagram

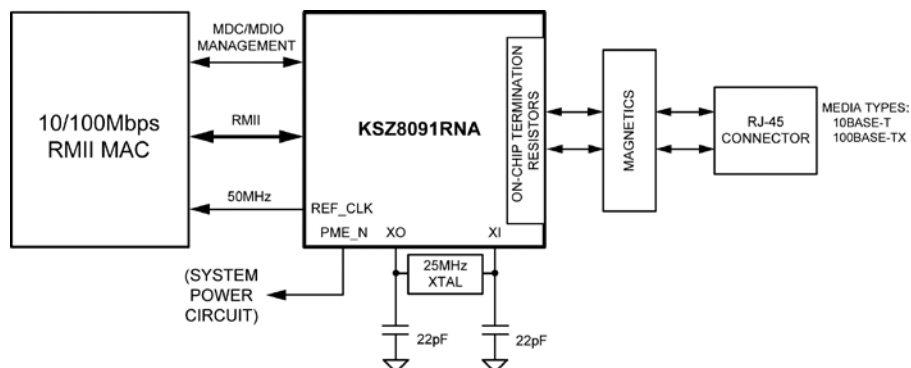

LinkMD is a registered trademark of Micrel, Inc.

Micrel Inc. • 2180 Fortune Drive • San Jose, CA 95131 • USA • tel +1 (408) 944-0800 • fax + 1 (408) 474-1000 • <http://www.micrel.com>

Features (Continued)

- Parametric NAND Tree support for fault detection between chip I/Os and the board
- Loopback modes for diagnostics
- Power-down and power-saving modes
- Single 3.3V power supply with VDD I/O options for 1.8V, 2.5V, or 3.3V
- Built-in 1.2V regulator for core
- Available in 24-pin (4mm x 4mm) QFN package

Applications

- Game console
- IP phone
- IP set-top box
- IP TV
- LOM
- Printer

Ordering Information

Ordering Part Number	Temperature Range	Package	Lead Finish	Description
KSZ8091RNACA	0°C to 70°C	24-Pin QFN	Pb-Free	RMII with 25MHz crystal/clock input and 50MHz RMII REF_CLK output, EEE and WoL Support, Commercial Temperature.
KSZ8091RNAIA ⁽¹⁾	-40°C to 85°C	24-Pin QFN	Pb-Free	RMII with 25MHz crystal/clock input and 50MHz RMII REF_CLK output, EEE and WoL Support, Industrial Temperature.
KSZ8091RNDCA	0°C to 70°C	24-Pin QFN	Pb-Free	RMII normal mode with 50MHz clock input, EEE and WoL Support, Commercial Temperature.
KSZ8091RNDIA ⁽¹⁾	-40°C to 85°C	24-Pin QFN	Pb-Free	RMII normal mode with 50MHz clock input, EEE and WoL Support, Industrial Temperature.
KSZ8091RNA-EVAL				KSZ8091RNA Evaluation Board (Mounted with KSZ8081RNA device in commercial temperature)
KSZ8091RND-EVAL				KSZ8091RND Evaluation Board (Mounted with KSZ8091RND device in commercial temperature)

Note:

1. Contact factory for lead time.

Revision History

Date	Change Description/Edits by:	Rev.
9/24/13	New datasheet.	1.0
12/2/14	Added silver wire bonding part numbers to Ordering Information. Updated Ordering Information to include Ordering Part Number and Device Marking.	1.1
8/31/15	Add Max frequency for MDC in MII Management (MIIM) Interface section. Updated ordering information Table. Updated descriptions for Figure 19. Add a note for Figure 20. Updated descriptions in local loopback section for data loopback path. Updated Table 16. Add a note for Table 18. Updated description and add an equation in LinkMD section. Add HBM ESD rating in Features.	1.2

Contents

List of Figures.....	6
List of Tables.....	7
Pin Configuration.....	8
Pin Description.....	9
Strapping Options.....	12
Functional Description: 10Base-T/100Base-TX Transceiver.....	13
100Base-TX Transmit.....	13
100Base-TX Receive.....	13
Scrambler/De-Scrambler (100Base-TX Only).....	13
10Base-T Transmit.....	14
10Base-T Receive.....	14
PLL Clock Synthesizer.....	14
Auto-Negotiation.....	14
RMII Data Interface.....	16
RMII Signal Definition.....	16
Reference Clock (REF_CLK).....	16
Transmit Enable (TXEN).....	16
Transmit Data[1:0] (TXD[1:0]).....	16
Carrier Sense/Receive Data Valid (CRS_DV).....	17
Receive Data[1:0] (RXD[1:0]).....	17
Receive Error (RXER).....	17
Collision Detection (COL).....	17
RMII Signal Diagram – 25/50MHz Clock Mode.....	17
RMII – 25MHz Clock Mode.....	17
RMII – 50MHz Clock Mode.....	18
Back-to-Back Mode – 100Mbps Copper Repeater.....	19
RMII Back-to-Back Mode.....	19
MII Management (MIIM) Interface.....	20
Interrupt (INTRP).....	20
HP Auto MDI/MDI-X.....	21
Straight Cable.....	21
Crossover Cable.....	22
Loopback Mode.....	22
Local (Digital) Loopback.....	22
Remote (Analog) Loopback.....	23
LinkMD [®] Cable Diagnostic.....	25
NAND Tree Support.....	26
NAND Tree I/O Testing.....	27
Power Management.....	28
Power-Saving Mode.....	28
Energy-Detect Power-Down Mode.....	28
Power-Down Mode.....	28
Slow-Oscillator Mode.....	28
Energy Efficient Ethernet (EEE).....	29
Transmit Direction Control (MAC-to-PHY).....	30
Receive Direction Control (PHY-to-MAC).....	30
Registers Associated with EEE.....	30

Wake-On-LAN	31
Magic-Packet Detection.....	31
Customized-Packet Detection	32
Link Status Change Detection	32
Reference Circuit for Power and Ground Connections.....	33
Typical Current/Power Consumption	34
Register Map	36
Standard Registers	38
IEEE-Defined Registers – Descriptions.....	38
Vendor-Specific Registers – Descriptions	43
MMD Registers.....	48
MMD Register Write	49
MMD Register Read	49
MMD Registers – Descriptions	50
Absolute Maximum Ratings	55
Operating Ratings	55
Electrical Characteristics	55
Timing Diagrams	57
RMII Timing	57
Auto-Negotiation Timing	58
MDC/MDIO Timing	59
Power-Up/Reset Timing	60
Reset Circuit.....	61
Reference Circuits – LED Strap-In Pin	62
Reference Clock – Connection and Selection	63
Magnetic – Connection and Selection	64
Package Information and Recommended Land Pattern.....	66

List of Figures

Figure 1. Auto-Negotiation Flow Chart.....	15
Figure 2. KSZ8091RNA/RND RMII Interface (RMII – 25MHz Clock Mode)	18
Figure 3. KSZ8091RNA/RND RMII Interface (RMII – 50MHz Clock Mode)	18
Figure 4. KSZ8091RNA/RND to KSZ8091RNA/RND Back-to-Back Copper Repeater.....	19
Figure 5. Typical Straight Cable Connection	21
Figure 6. Typical Crossover Cable Connection	22
Figure 7. Local (Digital) Loopback	23
Figure 8. Remote (Analog) Loopback	24
Figure 9. LPI Mode (Refresh Transmissions and Quiet Periods)	29
Figure 10. LPI Transition – RMII (100Mbps) Transmit.....	30
Figure 11. LPI Transition – RMII (100Mbps) Receive.....	30
Figure 12. KSZ8091RNA/RND Power and Ground Connections	33
Figure 13. RMII Timing – Data Received from RMII	57
Figure 14. RMII Timing – Data Input to RMII	57
Figure 15. Auto-Negotiation Fast Link Pulse (FLP) Timing	58
Figure 16. MDC/MDIO Timing.....	59
Figure 17. Power-Up/Reset Timing.....	60
Figure 18. Recommended Reset Circuit.....	61
Figure 19. Recommended Reset Circuit for Interfacing with CPU/FPGA Reset Output	61
Figure 20. Reference Circuits for LED Strapping Pin	62
Figure 21. 25MHz Crystal/Oscillator Reference Clock Connection	63
Figure 22. 50MHz Oscillator/Reference Clock Connection	63
Figure 23. Typical Magnetic Interface Circuit.....	64

List of Tables

Table 1. RMI Signal Definition.....	16
Table 2. RMI Signal Connection for RMI Back-to-Back Mode (100Base-TX Copper Repeater)	19
Table 3. MII Management Frame Format for the KSZ8091RNA/RND	20
Table 4. MDI/MDI-X Pin Definition	21
Table 5. NAND Tree Test Pin Order for KSZ8091RNA/RND	26
Table 6. KSZ8091RNA/RND Power Pin Description	33
Table 7. Typical Current/Power Consumption (VDDA_3.3 = 3.3V, VDDIO = 3.3V)	34
Table 8. Typical Current/Power Consumption (VDDA_3.3 = 3.3V, VDDIO = 2.5V)	34
Table 9. Typical Current/Power Consumption (VDDA_3.3 = 3.3V, VDDIO = 1.8V)	35
Table 10. Standard Registers Supported by KSZ8091RNA/RND	36
Table 11. MMD Registers Supported by KSZ8091RNA/RND	37
Table 12. Portal Registers (Access to Indirect MMD Registers).....	48
Table 13. RMI Timing Parameters – KSZ8091RNA/RND (25MHz input to XI pin, 50MHz output from REF_CLK pin)	57
Table 14. RMI Timing Parameters – KSZ8091RNA/RND (50MHz input to XI pin)	57
Table 15. Auto-Negotiation Fast Link Pulse (FLP) Timing Parameters.....	58
Table 16. MDC/MDIO Timing Parameters	59
Table 17. Power-Up/Reset Timing Parameters	60
Table 18. 25MHz Crystal/Reference Clock Selection Criteria	63
Table 19. 50MHz Oscillator/Reference Clock Selection Criteria	63
Table 20. Magnetics Selection Criteria	65
Table 21. Compatible Single-Port 10/100 Magnetics	65

Pin Configuration

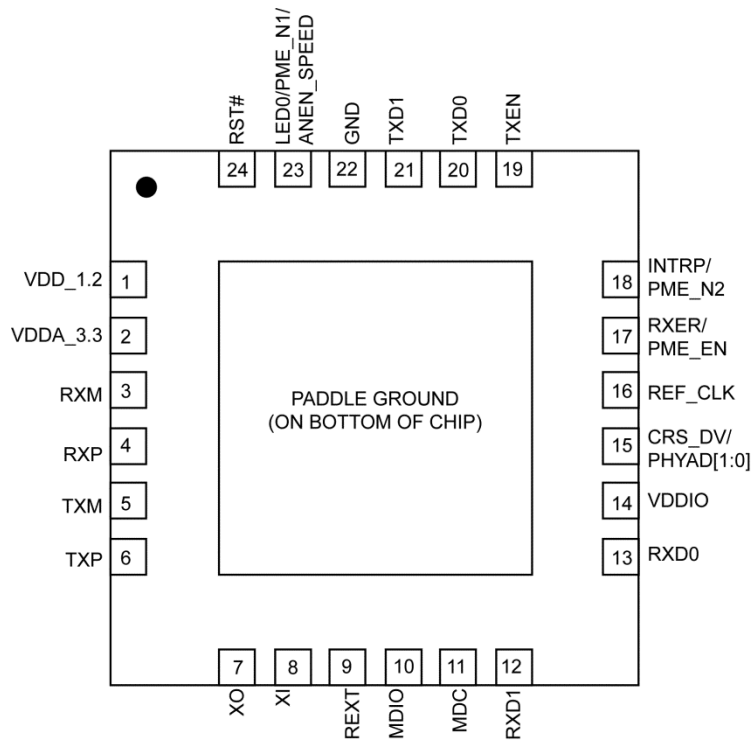

24-Pin (4mm x 4mm) QFN

Pin Description

Pin Number	Pin Name	Type ⁽²⁾	Pin Function
1	VDD_1.2	P	1.2V Core VDD (power supplied by KSZ8091RNA/KSZ8091RND). Decouple with 2.2 μ F and 0.1 μ F capacitors to ground.
2	VDDA_3.3	P	3.3V analog VDD.
3	RXM	I/O	Physical receive or transmit signal (– differential).
4	RXP	I/O	Physical receive or transmit signal (+ differential).
5	TXM	I/O	Physical transmit or receive signal (– differential).
6	TXP	I/O	Physical transmit or receive signal (+ differential).
7	XO	O	Crystal Feedback for 25MHz Crystal. This pin is a no connect if an oscillator or external clock source is used.
8	XI	I	<p>RMII – 25MHz Mode: 25MHz \pm50ppm Crystal/Oscillator/External Clock Input RMII – 50MHz Mode: 50MHz \pm50ppm Oscillator/External Clock Input For unmanaged mode (power-up default setting),</p> <ul style="list-style-type: none"> KSZ8091RNA takes in the 25MHz crystal/clock on this pin. KSZ8091RND takes in the 50MHz clock on this pin. <p>After power-up, both the KSZ8091RNA and KSZ8091RND can be programmed to either the 25MHz mode or 50MHz mode using PHY Register 1Fh, Bit [7]. See also REF_CLK (Pin 16).</p>
9	REXT	I	Set PHY Transmit Output Current Connect a 6.49k Ω resistor to ground on this pin.
10	MDIO	Ipu/Opu	Management Interface (MII) Data I/O. This pin has a weak pull-up, is open-drain, and requires an external 1.0k Ω pull-up resistor.
11	MDC	Ipu	Management Interface (MII) Clock Input. This clock pin is synchronous to the MDIO data pin.
12	RXD1	Ipd/O	RMII Receive Data Output[1] ⁽³⁾ .
13	RXD0	Ipu/O	RMII Receive Data Output[0] ⁽³⁾ .
14	VDDIO	P	3.3V, 2.5V, or 1.8V digital V _{DD} .

Notes:

2. P = Power supply.

GND = Ground.

I = Input.

O = Output.

I/O = Bi-directional.

Ipu = Input with internal pull-up (see [Electrical Characteristics](#) for value).

Ipu/O = Input with internal pull-up (see [Electrical Characteristics](#) for value) during power-up/reset; output pin otherwise.

Ipd/O = Input with internal pull-down (see [Electrical Characteristics](#) for value) during power-up/reset; output pin otherwise.

Ipu/Opu = Input with internal pull-up (see [Electrical Characteristics](#) for value) and output with internal pull-up (see [Electrical Characteristics](#) for value).

3. RMII RX Mode: The RXD[1:0] bits are synchronous with the 50MHz RMII Reference Clock. For each clock period in which CRS_DV is asserted, two bits of recovered data are sent by the PHY to the MAC.

Pin Description (Continued)

Pin Number	Pin Name	Type ⁽²⁾	Pin Function
15	CRS_DV / PHYAD[1:0]	lpd/O	RMII Mode: Carrier Sense/Receive Data Valid output Config Mode: The pull-up/pull-down value is latched as PHYAD[1:0] at the de-assertion of reset. See the Strapping Options section for details.
16	REF_CLK	lpd/O	RMII – 25MHz Mode: This pin provides the 50MHz RMII reference clock output to the MAC. RMII – 50MHz Mode: This pin is a no connect. For unmanaged mode (power-up default setting), <ul style="list-style-type: none"> KSZ8091RNA is in RMII – 25MHz mode and outputs the 50MHz RMII reference clock on this pin. KSZ8091RND is in RMII – 50MHz mode and does not use this pin. After power-up, both KSZ8091RNA and KSZ8091RND can be programmed to either 25MHz mode or 50MHz mode using PHY Register 1Fh, Bit [7]. See also XI (Pin 8).
17	RXER / PME_EN	lpd/O	RMII Mode: RMII Receive Error Output Config Mode: The pull-up/pull-down value is latched as PME_EN at the de-assertion of reset. See the Strapping Options section for details.
18	INTRP/ PME_N2	Ipu/Opu	Interrupt Output: Programmable interrupt output, with Register 1Bh as the Interrupt Control/Status register, for programming the interrupt conditions and reading the interrupt status. Register 1Fh, Bit [9] sets the interrupt output to active low (default) or active high. PME_N Output: Programmable PME_N output (pin option 2). When asserted low, this pin signals that a WOL event has occurred. This pin has a weak pull-up and is an open-drain. For Interrupt (when active low) and PME functions, this pin requires an external 1.0kΩ pull-up resistor to VDDIO (digital V _{DD}).
19	TXEN	I	RMII Transmit Enable Input
20	TXD0	I	RMII Transmit Data Input[0] ⁽⁴⁾
21	TXD1	I/O	RMII Mode: RMII Transmit Data Input[1] ⁽⁴⁾ NAND Tree Mode: NAND Tree Output
22	GND	GND	Ground

Note:

4. RMII TX Mode: The TXD[1:0] bits are synchronous with the 50MHz RMII Reference Clock. For each clock period in which TXEN is asserted, two bits of data are received by the PHY from the MAC.

Pin Description (Continued)

Pin Number	Pin Name	Type ⁽²⁾	Pin Function																											
23	LED0/ PME_N1/ ANEN_SPEED	Ipu/O	<p>LED Output: Programmable LED0 output</p> <p>PME_N Output: Programmable PME_N Output (pin option 1). When asserted low, this pin signals that a WOL event has occurred. In this mode, this pin has a weak pull-up, is an open-drain, and requires an external 1.0kΩ pull-up resistor to VDDIO (digital VDD).</p> <p>Config Mode: Latched as Auto-Negotiation enable (Register 0h, Bit [12]) and Speed (Register 0h, Bit [13]) at the de-assertion of reset. See the Strapping Options section for details.</p> <p>The LED0 pin is programmable using Register 1Fh, Bits [5:4], and is defined as follows.</p> <table border="1"> <thead> <tr> <th colspan="3">LED Mode = [00]</th> </tr> <tr> <th>Link/Activity</th> <th>Pin State</th> <th>LED Definition</th> </tr> </thead> <tbody> <tr> <td>No link</td> <td>High</td> <td>OFF</td> </tr> <tr> <td>Link</td> <td>Low</td> <td>ON</td> </tr> <tr> <td>Activity</td> <td>Toggle</td> <td>Blinking</td> </tr> </tbody> </table> <table border="1"> <thead> <tr> <th colspan="3">LED Mode = [01]</th> </tr> <tr> <th>Link</th> <th>Pin State</th> <th>LED Definition</th> </tr> </thead> <tbody> <tr> <td>No link</td> <td>High</td> <td>OFF</td> </tr> <tr> <td>Link</td> <td>Low</td> <td>ON</td> </tr> </tbody> </table> <p>LED Mode = [10], [11] Reserved</p>	LED Mode = [00]			Link/Activity	Pin State	LED Definition	No link	High	OFF	Link	Low	ON	Activity	Toggle	Blinking	LED Mode = [01]			Link	Pin State	LED Definition	No link	High	OFF	Link	Low	ON
LED Mode = [00]																														
Link/Activity	Pin State	LED Definition																												
No link	High	OFF																												
Link	Low	ON																												
Activity	Toggle	Blinking																												
LED Mode = [01]																														
Link	Pin State	LED Definition																												
No link	High	OFF																												
Link	Low	ON																												
24	RST#	Ipu	Chip Reset (active low)																											
PADDLE	GND	GND	Ground																											

Strapping Options

Pin Number	Pin Name	Type ⁽⁵⁾	Pin Function
15	PHYAD[1:0]	lpd/O	<p>The PHY Address is latched at the de-assertion of reset and is configurable to either one of the following two values:</p> <p>Pull-up = PHY Address is set to 00011b (3h) Pull-down (default) = PHY Address is set to 00000b (0h)</p> <p>PHY Address 0 is assigned by default as the broadcast PHY address, but it can be assigned as a unique PHY address after writing a '1' to Register 16h, Bit [9]. PHY Address bits [4:2] are set to 000 by default.</p>
17	PME_EN	lpd/O	<p>PME Output for Wake-On-LAN</p> <p>Pull-up = Enable Pull-down (default) = Disable</p> <p>At the de-assertion of reset, this pin value is latched into Register 16h, Bit [15].</p>
23	ANEN_SPEED	lpu/O	<p>Auto-Negotiation Enable and Speed Mode</p> <p>Pull-up (default) = Enable Auto-Negotiation and set 100Mbps Speed Pull-down = Disable Auto-Negotiation and set 10Mbps Speed</p> <p>At the de-assertion of reset, this pin value is latched into Register 0h, Bit [12] for Auto-Negotiation enable/disable, Register 0h, Bit [13] for the Speed select, and Register 4h (Auto-Negotiation Advertisement) for the Speed capability support.</p>

Note:

5. lpu/O = Input with internal pull-up (see [Electrical Characteristics](#) for value) during power-up/reset; output pin otherwise.
 lpd/O = Input with internal pull-down (see [Electrical Characteristics](#) for value) during power-up/reset; output pin otherwise.

The PHYAD[1:0] and PME_EN strap-in pins are latched at the de-assertion of reset. In some systems, the RMII MAC receive input pins may drive high/low during power-up or reset, and consequently cause the PHYAD[1:0] and PME_EN strap-in pins, shared pin with the RMII CRS_DV and RXER signals respectively, to be latched to the unintended high/low state. In this case an external pull-up (4.7kΩ) or pull-down (1.0kΩ) should be added on the PHYAD[1:0] and PME_EN strap-in pins to ensure that the intended value is strapped-in correctly.

Functional Description: 10Base-T/100Base-TX Transceiver

The KSZ8091RNA is an integrated single 3.3V supply Fast Ethernet transceiver. It is fully compliant with the IEEE 802.3 Specification, and reduces board cost and simplifies board layout by using on-chip termination resistors for the two differential pairs and by integrating the regulator to supply the 1.2V core.

On the copper media side, the KSZ8091RNA supports 10Base-T and 100Base-TX for transmission and reception of data over a standard CAT-5 unshielded twisted pair (UTP) cable, and HP Auto MDI/MDI-X for reliable detection of and correction for straight-through and crossover cables.

On the MAC processor side, the KSZ8091RNA offers the Reduced Media Independent Interface (RMII) for direct connection with RMII-compliant Ethernet MAC processors and switches

The MII management bus option gives the MAC processor complete access to the KSZ8091RNA control and status registers. Additionally, an interrupt pin eliminates the need for the processor to poll for PHY status change.

As the power-up default, the KSZ8091RNA uses a 25MHz crystal to generate all required clocks, including the 50MHz RMII reference clock output for the MAC. The KSZ8091RND version uses the 50MHz RMII reference clock as the power-up default.

The KSZ8091RNA/RND is used to refer to both KSZ8091RNA and KSZ8091RND versions in this datasheet.

100Base-TX Transmit

The 100Base-TX transmit function performs parallel-to-serial conversion, 4B/5B encoding, scrambling, NRZ-to-NRZI conversion, and MLT3 encoding and transmission.

The circuitry starts with a parallel-to-serial conversion, which converts the RMII data from the MAC into a 125MHz serial bit stream. The data and control stream is then converted into 4B/5B coding and followed by a scrambler. The serialized data is further converted from NRZ-to-NRZI format, and then transmitted in MLT3 current output. The output current is set by an external 6.49k Ω 1% resistor for the 1:1 transformer ratio.

The output signal has a typical rise/fall time of 4ns and complies with the ANSI TP-PMD standard regarding amplitude balance, overshoot, and timing jitter. The wave-shaped 10Base-T output is also incorporated into the 100Base-TX transmitter.

100Base-TX Receive

The 100Base-TX receiver function performs adaptive equalization, DC restoration, MLT3-to-NRZI conversion, data and clock recovery, NRZI-to-NRZ conversion, de-scrambling, 4B/5B decoding, and serial-to-parallel conversion.

The receiving side starts with the equalization filter to compensate for inter-symbol interference (ISI) over the twisted pair cable. Because the amplitude loss and phase distortion is a function of the cable length, the equalizer must adjust its characteristics to optimize performance. In this design, the variable equalizer makes an initial estimation based on comparisons of incoming signal strength against some known cable characteristics, then tunes itself for optimization. This is an ongoing process and self-adjusts against environmental changes such as temperature variations.

Next, the equalized signal goes through a DC-restoration and data-conversion block. The DC-restoration circuit compensates for the effect of baseline wander and improves the dynamic range. The differential data-conversion circuit converts MLT3 format back to NRZI. The slicing threshold is also adaptive.

The clock-recovery circuit extracts the 125MHz clock from the edges of the NRZI signal. This recovered clock is then used to convert the NRZI signal to NRZ format. This signal is sent through the de-scrambler, then the 4B/5B decoder. Finally, the NRZ serial data is converted to RMII format and provided as the input data to the MAC.

Scrambler/De-Scrambler (100Base-TX Only)

The scrambler spreads the power spectrum of the transmitted signal to reduce electromagnetic interference (EMI) and baseline wander. The de-scrambler recovers the scrambled signal.

10Base-T Transmit

The 10Base-T drivers are incorporated with the 100Base-TX drivers to allow for transmission using the same magnetic. The drivers perform internal wave-shaping and pre-emphasis, and output 10Base-T signals with a typical amplitude of 2.5V peak for standard 10Base-T mode and 1.75V peak for energy-efficient 10Base-Te mode. The 10Base-T/10Base-Te signals have harmonic contents that are at least 27dB below the fundamental frequency when driven by an all-ones Manchester-encoded signal.

10Base-T Receive

On the receive side, input buffer and level detecting squelch circuits are used. A differential input receiver circuit and a phase-locked loop (PLL) performs the decoding function. The Manchester-encoded data stream is separated into clock signal and NRZ data. A squelch circuit rejects signals with levels less than 400mV, or with short pulse widths, to prevent noise at the differential line receive inputs from falsely triggering the decoder. When the input exceeds the squelch limit, the PLL locks onto the incoming signal and the KSZ8091RNA/RND decodes a data frame. The receive clock is kept active during idle periods between data receptions.

PLL Clock Synthesizer

The KSZ8091RNA/RND in RMII – 25MHz Clock mode generates all internal clocks and all external clocks for system timing from an external 25MHz crystal, oscillator, or reference clock. For the KSZ8091RNA/RND in RMII – 50MHz clock mode, these clocks are generated from an external 50MHz oscillator or system clock.

Auto-Negotiation

The KSZ8091RNA/RND conforms to the Auto-Negotiation protocol, defined in Clause 28 of the IEEE 802.3 Specification. Auto-Negotiation allows unshielded twisted pair (UTP) link partners to select the highest common mode of operation.

During Auto-Negotiation, link partners advertise capabilities across the UTP link to each other and then compare their own capabilities with those they received from their link partners. The highest speed and duplex setting that is common to the two link partners is selected as the mode of operation.

The following list shows the speed and duplex operation mode from highest to lowest priority.

- Priority 1: 100Base-TX, full-duplex
- Priority 2: 100Base-TX, half-duplex
- Priority 3: 10Base-T, full-duplex
- Priority 4: 10Base-T, half-duplex

If Auto-Negotiation is not supported or the KSZ8091RNA/RND link partner is forced to bypass Auto-Negotiation, then the KSZ8091RNA/RND sets its operating mode by observing the signal at its receiver. This is known as parallel detection, which allows the KSZ8091RNA/RND to establish a link by listening for a fixed signal protocol in the absence of the Auto-Negotiation advertisement protocol.

Auto-Negotiation is enabled by either hardware pin strapping (ANEN_SPEED, Pin 23) or software (Register 0h, Bit [12]).

By default, Auto-Negotiation is enabled after power-up or hardware reset. After that, Auto-Negotiation can be enabled or disabled by Register 0h, Bit [12]. If Auto-Negotiation is disabled, the speed is set by Register 0h, Bit [13], and the duplex is set by Register 0h, Bit [8].

The Auto-Negotiation link-up process is shown in [Figure 1](#).

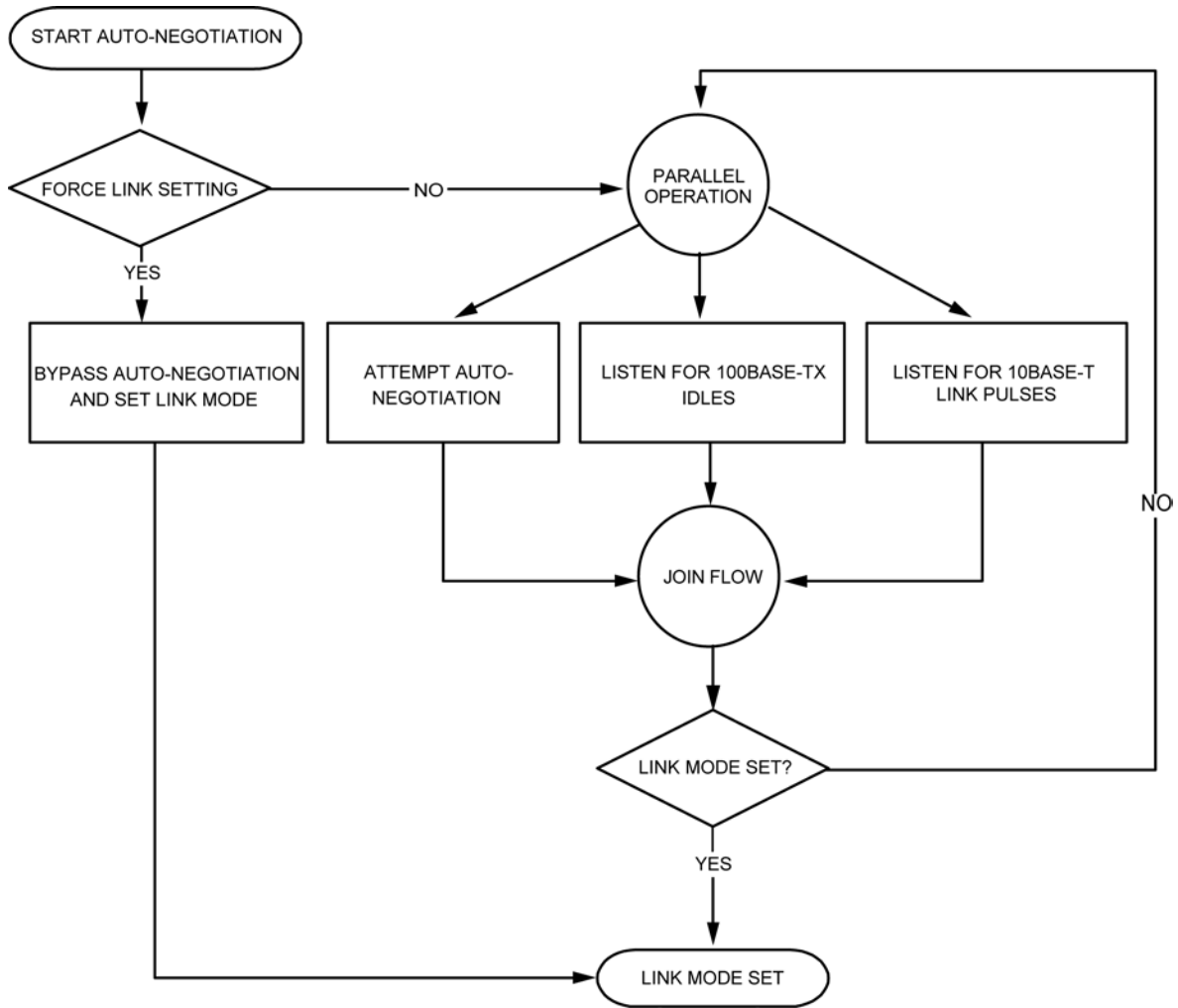

Figure 1. Auto-Negotiation Flow Chart

RMII Data Interface

The Reduced Media Independent Interface (RMII) specifies a low pin count Media Independent Interface (MII). It provides a common interface between physical layer and MAC layer devices, and has the following key characteristics:

- Pin count is 8 pins (3 pins for data transmission, 4 pins for data reception, and 1 pin for the 50MHz reference clock).
- 10Mbps and 100Mbps data rates are supported at both half- and full-duplex.
- Data transmission and reception are independent and belong to separate signal groups.
- Transmit data and receive data are each 2 bits wide, a dibit.

RMII Signal Definition

Table 1 describes the RMII signals. Refer to RMII Specification v1.2 for detailed information.

Table 1. RMII Signal Definition

RMII Signal Name	Direction (with respect to PHY, KSZ8091RNA/RND signal)	Direction (with respect to MAC)	Description
REF_CLK	Output (25MHz clock mode)/ <no connect> (50MHz clock mode)	Input/ Input or <no connect>	Synchronous 50MHz reference clock for receive, transmit, and control interface
TXEN	Input	Output	Transmit Enable
TXD[1:0]	Input	Output	Transmit Data[1:0]
CRS_DV	Output	Input	Carrier Sense/Receive Data Valid
RXD[1:0]	Output	Input	Receive Data[1:0]
RXER	Output	Input, or (not required)	Receive Error

Reference Clock (REF_CLK)

REF_CLK is a continuous 50MHz clock that provides the timing reference for TXEN, TXD[1:0], CRS_DV, RXD[1:0], and RX_ER.

For RMII – 25MHz Clock Mode, the KSZ8091RNA/RND generates and outputs the 50MHz RMII REF_CLK to the MAC at REF_CLK (Pin 16).

For RMII – 50MHz Clock Mode, the KSZ8091RNA/RND takes in the 50MHz RMII REF_CLK from the MAC or system board at XI (Pin 8) and leaves the REF_CLK (Pin 16) as no connect.

Transmit Enable (TXEN)

TXEN indicates that the MAC is presenting dibits on TXD[1:0] for transmission. It is asserted synchronously with the first dibit of the preamble and remains asserted while all dibits to be transmitted are presented on the RMII. It is negated before the first REF_CLK following the final dibit of a frame.

TXEN transitions synchronously with respect to REF_CLK.

Transmit Data[1:0] (TXD[1:0])

When TXEN is asserted, TXD[1:0] are the data dibits presented by the MAC and accepted by the PHY for transmission.

When TXEN is de-asserted, the MAC drives TXD[1:0] to either 00 for the idle state (non-EEE mode) or 01 for the LPI state (EEE mode).

TXD[1:0] transitions synchronously with respect to REF_CLK.

Carrier Sense/Receive Data Valid (CRS_DV)

The PHY asserts CRS_DV when the receive medium is non-idle. It is asserted asynchronously when a carrier is detected. This happens when squelch is passed in 10Mbps mode, and when two non-contiguous 0s in 10 bits are detected in 100Mbps mode. Loss of carrier results in the de-assertion of CRS_DV.

While carrier detection criteria are met, CRS_DV remains asserted continuously from the first recovered dibit of the frame through the final recovered dibit. It is negated before the first REF_CLK that follows the final dibit. The data on RXD[1:0] is considered valid after CRS_DV is asserted. However, because the assertion of CRS_DV is asynchronous relative to REF_CLK, the data on RXD[1:0] is 00 until receive signals are properly decoded.

Receive Data[1:0] (RXD[1:0])

For each clock period in which CRS_DV is asserted, RXD[1:0] transfers a dibit of recovered data from the PHY.

When CRS_DV is de-asserted, the PHY drives RXD[1:0] to either 00 for the idle state (non-EEE mode) or 01 for the LPI state (EEE mode).

RXD[1:0] transitions synchronously with respect to REF_CLK.

Receive Error (RXER)

When CRS_DV is asserted, RXER is asserted for one or more REF_CLK periods to indicate that a symbol error (for example, a coding error that a PHY can detect that may otherwise be undetectable by the MAC sub-layer) is detected somewhere in the frame that is being transferred from the PHY to the MAC.

RXER transitions synchronously with respect to REF_CLK.

Collision Detection (COL)

The MAC regenerates the COL signal of the MII from TXEN and CRS_DV.

RMII Signal Diagram – 25/50MHz Clock Mode

The KSZ8091RNA/RND RMII pin connections to the MAC for 25MHz clock mode are shown in [Figure 2](#). The connections for 50MHz clock mode are shown in [Figure 3](#).

RMII – 25MHz Clock Mode

The KSZ8091RNA is configured to RMII – 25MHz clock mode after it is powered up or hardware reset with the following:

- A 25MHz crystal connected to XI, XO (Pins 8, 7), or an external 25MHz clock source (oscillator) connected to XI

The KSZ8091RND can optionally be configured to RMII – 25MHz clock mode after it is powered up or hardware reset and software programmed with the following:

- A 25MHz crystal connected to XI, XO (Pins 8, 7), or an external 25MHz clock source (oscillator) connected to XI
- Register 1Fh, Bit [7] programmed to '1' to select RMII – 25MHz clock mode

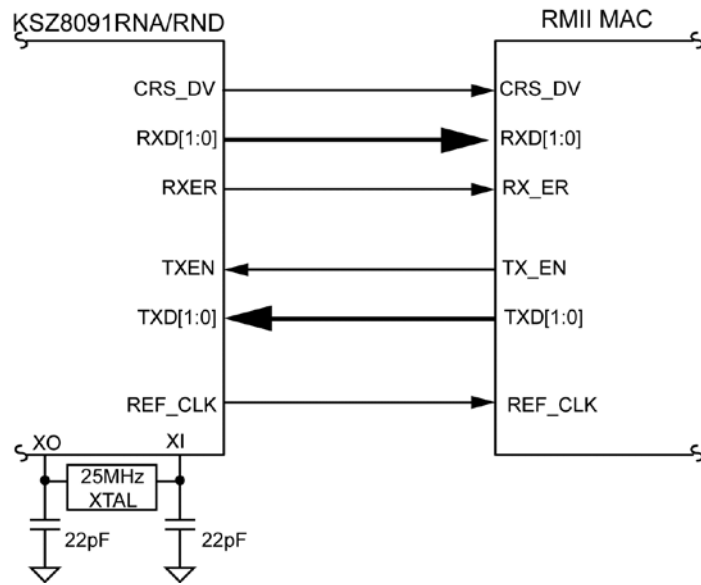

Figure 2. KSZ8091RNA/RND RMI Interface (RMII – 25MHz Clock Mode)

RMII – 50MHz Clock Mode

The KSZ8091RND is configured to RMII – 50MHz clock mode after it is powered up or hardware reset with the following:

- An external 50MHz clock source (oscillator) connected to XI (Pin 8)

The KSZ8091RNA can optionally be configured to RMII – 50MHz clock mode after it is powered up or hardware reset and software programmed with the following:

- An external 50MHz clock source (oscillator) connected to XI (Pin 8)
- Register 1Fh, Bit [7] programmed to ‘1’ to select RMII – 50MHz clock mode

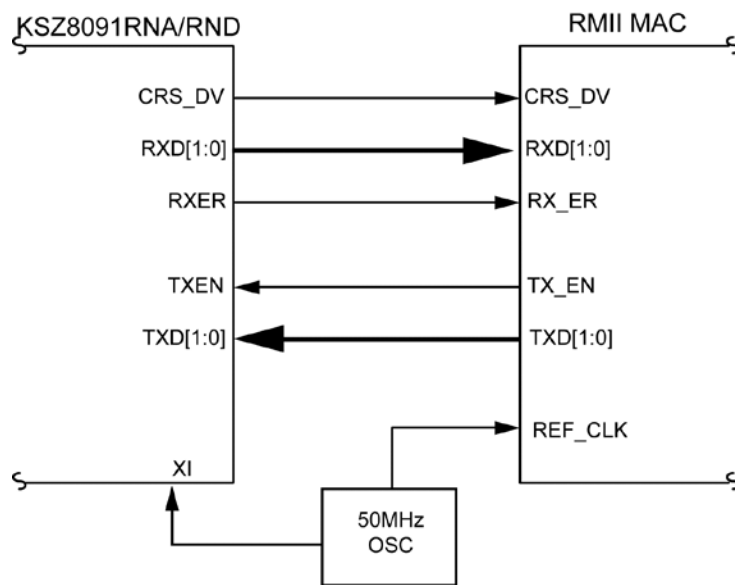

Figure 3. KSZ8091RNA/RND RMI Interface (RMII – 50MHz Clock Mode)

Back-to-Back Mode – 100Mbps Copper Repeater

Two KSZ8091RNA/RND devices can be connected back-to-back to form a managed 100Base-TX copper repeater.

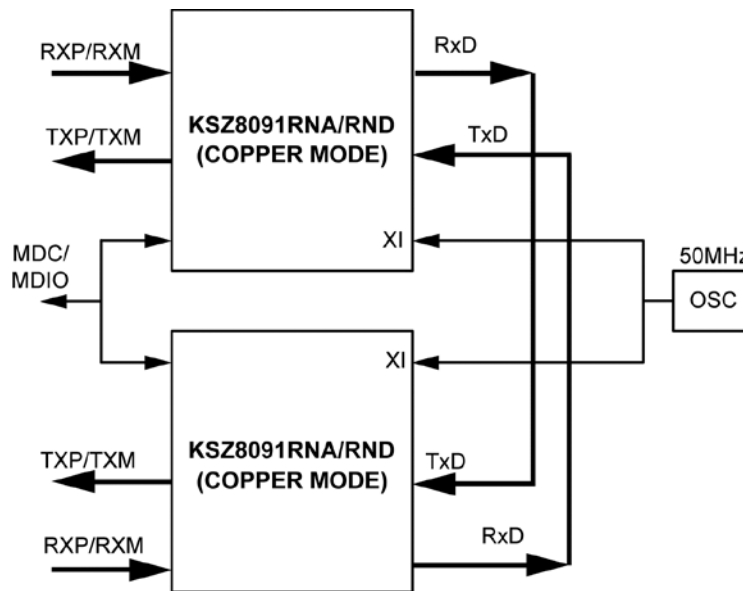

Figure 4. KSZ8091RNA/RND to KSZ8091RNA/RND Back-to-Back Copper Repeater

RMII Back-to-Back Mode

In RMII back-to-back mode, a KSZ8091RNA/RND interfaces with another KSZ8091RNA/RND to provide a 100Mbps copper repeater solution.

The KSZ8091RNA/RND devices are configured to RMII back-to-back mode after power-up or reset, and software programming, with the following:

- A common 50MHz reference clock connected to XI (Pin 8) of both KSZ8091RNA/RND devices.
- Register 1Fh, Bit [7] programmed to '1' to select RMII – 50MHz clock mode for KSZ8091RNA. (KSZ8091RND is set to RMII – 50MHz clock mode as the default after power up or hardware reset).
- Register 16h, Bits [6] and [1] programmed to '1' and '1', respectively, to enable RMII back-to-back mode.
- RMII signals connected as shown in [Table 2](#).

Table 2. RMII Signal Connection for RMII Back-to-Back Mode (100Base-TX Copper Repeater)

KSZ8091RNA/RND (100Base-TX copper) [Device 1]			KSZ8091RNA/RND (100Base-TX copper) [Device 2]		
Pin Name	Pin Number	Pin Type	Pin Name	Pin Number	Pin Type
CRSDV	15	Output	TXEN	19	Input
RXD1	12	Output	TXD1	21	Input
RXD0	13	Output	TXD0	20	Input
TXEN	19	Input	CRSDV	15	Output
TXD1	21	Input	RXD1	12	Output
TXD0	20	Input	RXD0	13	Output

MII Management (MIIM) Interface

The KSZ8091RNA/RND supports the IEEE 802.3 MII management interface, also known as the Management Data Input/Output (MDIO) interface. This interface allows an upper-layer device, such as a MAC processor, to monitor and control the state of the KSZ8091RNA/RND. An external device with MIIM capability is used to read the PHY status and/or configure the PHY settings. More details about the MIIM interface can be found in Clause 22.2.4 of the IEEE 802.3 Specification.

The MIIM interface consists of the following:

- A physical connection that incorporates the clock line (MDC) and the data line (MDIO).
- A specific protocol that operates across the physical connection mentioned earlier, which allows the external controller to communicate with one or more PHY devices.
- A 32-register address space for direct access to IEEE-defined registers and vendor-specific registers, and for indirect access to MMD addresses and registers. See the [Register Map](#) section.

The KSZ8091RNA/RND supports only two unique PHY addresses. The PHYAD[1:0] strapping pin is used to select either 0h or 3h as the unique PHY address for the KSZ8091RNA/RND device.

PHY Address 0h is defined as the broadcast PHY address according to the IEEE 802.3 Specification, and can be used to read/write to a single PHY device, or write to multiple PHY devices simultaneously. For the KSZ8091RNA/RND, PHY Address 0h defaults to the broadcast PHY address after power-up, but PHY Address 0h can be disabled as the broadcast PHY address using software to assign it as a unique PHY address.

For applications that require two KSZ8091RNA/RND PHYs to share the same MDIO interface with one PHY set to Address 0h and the other PHY set to Address 3h, use PHY Address 0h (defaults to broadcast after power-up) to set both PHYs' Register 16h, Bit [9] to '1' to assign PHY Address 0h as a unique (non-broadcast) PHY address.

The MIIM interface can operate up to a maximum clock speed of 10MHz MAC clock.

[Table 3](#) shows the MII management frame format for the KSZ8091RNA/RND.

Table 3. MII Management Frame Format for the KSZ8091RNA/RND

	Preamble	Start of Frame	Read/Write OP Code	PHY Address Bits [4:0]	REG Address Bits [4:0]	TA	Data Bits [15:0]	Idle
Read	32 1's	01	10	000AA	RRRRR	Z0	DDDDDDDD_DDDDDDDD	Z
Write	32 1's	01	01	000AA	RRRRR	10	DDDDDDDD_DDDDDDDD	Z

Interrupt (INTRP)

INTRP (Pin 18) is an optional interrupt signal that is used to inform the external controller that there has been a status update to the KSZ8091RNA/RND PHY register. Bits [15:8] of Register 1Bh are the interrupt control bits to enable and disable the conditions for asserting the INTRP signal. Bits [7:0] of Register 1Bh are the interrupt status bits to indicate which interrupt conditions have occurred. The interrupt status bits are cleared after reading Register 1Bh.

Bit [9] of Register 1Fh sets the interrupt level to active high or active low. The default is active low.

The MII management bus option gives the MAC processor complete access to the KSZ8091RNA/RND control and status registers. Additionally, an interrupt pin eliminates the need for the processor to poll the PHY for status change.

HP Auto MDI/MDI-X

HP Auto MDI/MDI-X configuration eliminates the need to decide whether to use a straight cable or a crossover cable between the KSZ8091RNA/RND and its link partner. This feature allows the KSZ8091RNA/RND to use either type of cable to connect with a link partner that is in either MDI or MDI-X mode. The auto-sense function detects transmit and receive pairs from the link partner and assigns transmit and receive pairs to the KSZ8091RNA/RND accordingly.

HP Auto MDI/MDI-X is enabled by default. It is disabled by writing a '1' to Register 1Fh, Bit [13]. MDI and MDI-X mode is selected by Register 1Fh, Bit [14] if HP Auto MDI/MDI-X is disabled.

An isolation transformer with symmetrical transmit and receive data paths is recommended to support Auto MDI/MDI-X.

Table 4 shows how the IEEE 802.3 Standard defines MDI and MDI-X.

Table 4. MDI/MDI-X Pin Definition

MDI		MDI-X	
RJ-45 Pin	Signal	RJ-45 Pin	Signal
1	TX+	1	RX+
2	TX-	2	RX-
3	RX+	3	TX+
6	RX-	6	TX-

Straight Cable

A straight cable connects an MDI device to an MDI-X device, or an MDI-X device to an MDI device. Figure 5 shows a typical straight cable connection between a NIC card (MDI device) and a switch or hub (MDI-X device).

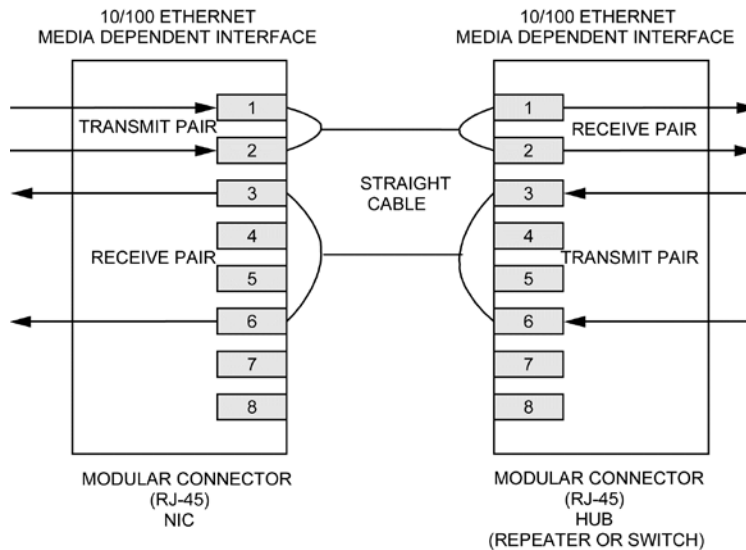

Figure 5. Typical Straight Cable Connection

Crossover Cable

A crossover cable connects an MDI device to another MDI device, or an MDI-X device to another MDI-X device. [Figure 6](#) shows a typical crossover cable connection between two switches or hubs (two MDI-X devices).

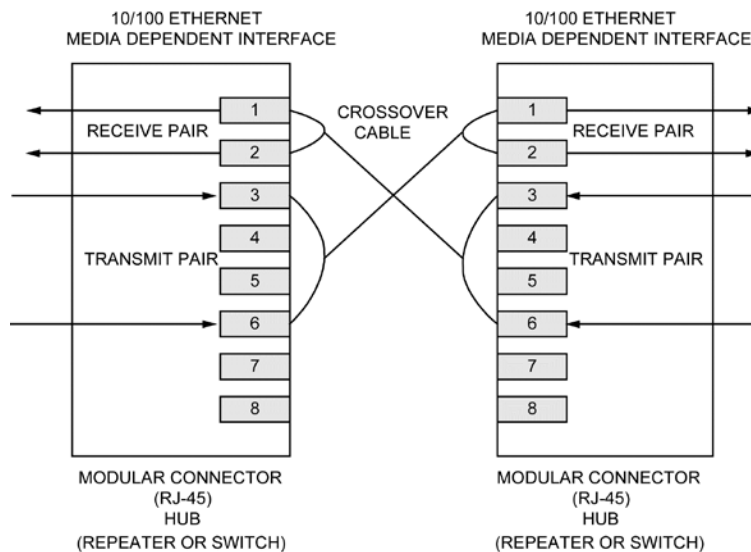

Figure 6. Typical Crossover Cable Connection

Loopback Mode

The KSZ8091RNA/RND supports the following loopback operations to verify analog and/or digital data paths.

- Local (digital) loopback
- Remote (analog) loopback

Local (Digital) Loopback

This loopback mode checks the RMII transmit and receive data paths between the KSZ8091RNA/RND and the external MAC, and is supported for both speeds (10/100Mbps) at full-duplex.

The loopback data path is shown in [Figure 7](#).

1. The RMII MAC transmits frames to the KSZ8091RNA/RND.
2. Frames are wrapped around inside the KSZ8091RNA/RND.
3. The KSZ8091RNA/RND transmits frames back to the RMII MAC.
4. Except the frames back to the RMII MAC, the transmit frames also go out from the copper port.

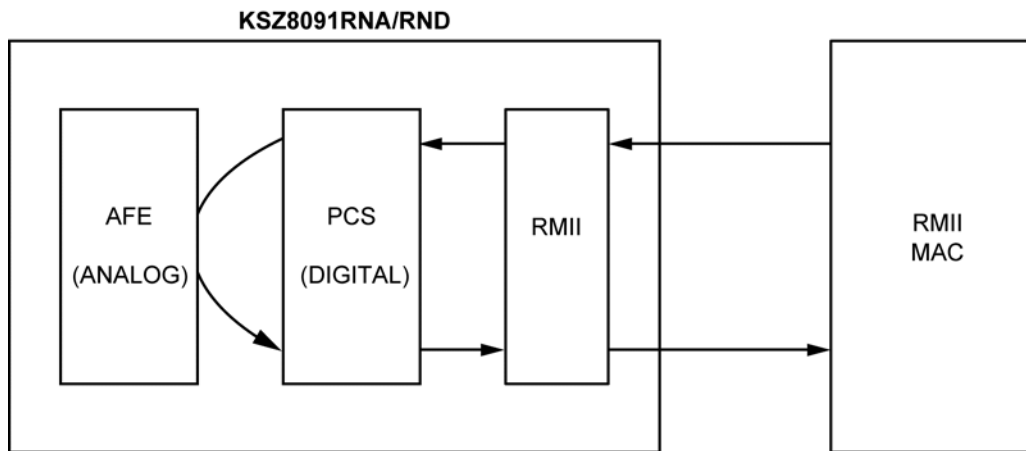

Figure 7. Local (Digital) Loopback

The following programming action and register settings are used for local loopback mode.

For 10/100Mbps loopback,

Set Register 0h,

```

Bit [14] = 1      // Enable local loopback mode
Bit [13] = 0/1   // Select 10Mbps/100Mbps speed
Bit [12] = 0     // Disable Auto-Negotiation
Bit [8] = 1      // Select full-duplex mode

```

Remote (Analog) Loopback

This loopback mode checks the line (differential pairs, transformer, RJ-45 connector, Ethernet cable) transmit and receive data paths between the KSZ8091RNA/RND and its link partner, and is supported for 100Base-TX full-duplex mode only.

The loopback data path is shown in [Figure 8](#).

1. The Fast Ethernet (100Base-TX) PHY link partner transmits frames to the KSZ8091RNA/RND.
2. Frames are wrapped around inside the KSZ8091RNA/RND.
3. The KSZ8091RNA/RND transmits frames back to the Fast Ethernet (100Base-TX) PHY link partner.

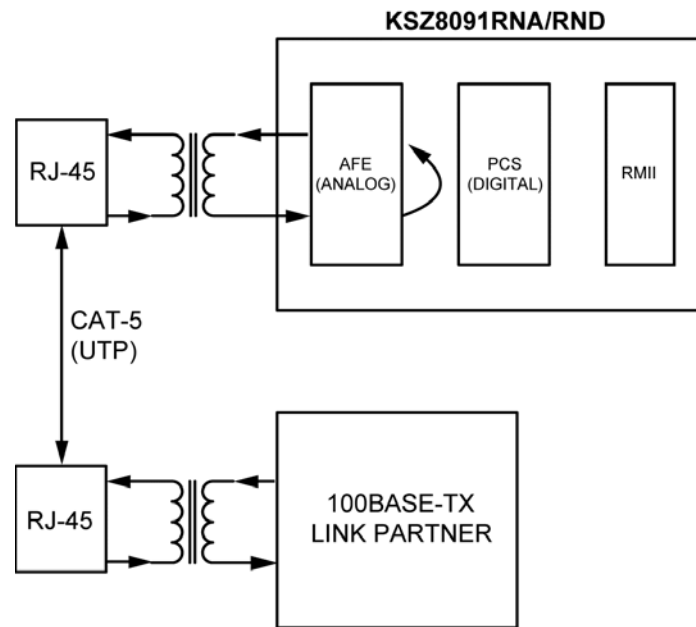

Figure 8. Remote (Analog) Loopback

The following programming steps and register settings are used for remote loopback mode.

1. Set Register 0h,
 - Bit [13] = 1 // Select 100Mbps speed
 - Bit [12] = 0 // Disable Auto-Negotiation
 - Bit [8] = 1 // Select full-duplex mode
 Or just auto-negotiate and link up with the link partner at 100Base-TX full-duplex mode.
2. Set Register 1Fh,
 - Bit [2] = 1 // Enable remote loopback mode

LinkMD[®] Cable Diagnostic

The LinkMD function uses time-domain reflectometry (TDR) to analyze the cabling plant for common cabling problems. These include open circuits, short circuits, and impedance mismatches.

LinkMD works by sending a pulse of known amplitude and duration down the MDI or MDI-X pair, then analyzing the shape of the reflected signal to determine the type of fault. The time duration for the reflected signal to return provides the approximate distance to the cabling fault. The LinkMD function processes this TDR information and presents it as a numerical value that can be translated to a cable distance.

LinkMD is initiated by accessing Register 1Dh, the LinkMD Cable Diagnostic Register, in conjunction with Register 1Fh, the PHY Control 2 Register. The latter register is used to disable Auto MDI/MDI-X and to select either MDI or MDI-X as the cable differential pair for testing.

Usage

The following is a sample procedure for using LinkMD with Registers 1Dh and 1Fh:

3. Disable auto MDI/MDI-X by writing a '1' to Register 1Fh, bit [13].
4. Start cable diagnostic test by writing a '1' to Register 1Dh, bit [15]. This enable bit is self-clearing.
5. Wait (poll) for Register 1Dh, bit [15] to return a '0', and indicating cable diagnostic test is completed.
6. Read cable diagnostic test results in Register 1Dh, bits [14:13]. The results are as follows:
 - 00 = normal condition (valid test)
 - 01 = open condition detected in cable (valid test)
 - 10 = short condition detected in cable (valid test)
 - 11 = cable diagnostic test failed (invalid test)

The '11' case, invalid test, occurs when the device is unable to shut down the link partner. In this instance, the test is not run, since it would be impossible for the device to determine if the detected signal is a reflection of the signal generated or a signal from another source.

7. Get distance to fault by concatenating Register 1Dh, bits [8:0] and multiplying the result by a constant of 0.38. The distance to the cable fault can be determined by the following formula:

$$D \text{ (distance to cable fault)} = 0.38 \times (\text{Register 1Dh, bits [8:0]})$$

D (distance to cable fault) is expressed in meters.

Concatenated value of Registers 1Dh bits [8:0] should be converted to decimal before multiplying by 0.38.

The constant (0.38) may be calibrated for different cabling conditions, including cables with a velocity of propagation that varies significantly from the norm.

NAND Tree Support

The KSZ8091RNA/RND provides parametric NAND tree support for fault detection between chip I/Os and board. The NAND tree is a chain of nested NAND gates in which each KSZ8091RNA/RND digital I/O (NAND tree input) pin is an input to one NAND gate along the chain. At the end of the chain, the TXD1 pin provides the output for the nested NAND gates.

The NAND tree test process includes:

- Enabling NAND tree mode
- Pulling all NAND tree input pins high
- Driving each NAND tree input pin low, sequentially, according to the NAND tree pin order
- Checking the NAND tree output to make sure there is a toggle high-to-low or low-to-high for each NAND tree input driven low

[Table 5](#) lists the NAND tree pin order

Table 5. NAND Tree Test Pin Order for KSZ8091RNA/RND

Pin Number	Pin Name	NAND Tree Description
10	MDIO	Input
11	MDC	Input
12	RXD1	Input
13	RXD0	Input
15	CRS_DV	Input
16	REF_CLK	Input
18	INTRP	Input
19	TXEN	Input
23	LED0	Input
20	TXD0	Input
21	TXD1	Output

NAND Tree I/O Testing

Use the following procedure to check for faults on the KSZ8091RNA/RND digital I/O pin connections to the board:

1. Enable NAND tree mode by setting Register 16h, Bit [5] to '1'.
2. Use board logic to drive all KSZ8091RNA/RND NAND tree input pins high.
3. Use board logic to drive each NAND tree input pin, in KSZ8091RNA/RND NAND tree pin order, as follows:
 - a. Toggle the first pin (MDIO) from high to low, and verify that the TXD1 pin switches from high to low to indicate that the first pin is connected properly.
 - b. Leave the first pin (MDIO) low.
 - c. Toggle the second pin (MDC) from high to low, and verify that the TXD1 pin switches from low to high to indicate that the second pin is connected properly.
 - d. Leave the first pin (MDIO) and the second pin (MDC) low.
 - e. Toggle the third pin (RXD1) from high to low, and verify that the TXD1 pin switches from high to low to indicate that the third pin is connected properly.
 - f. Continue with this sequence until all KSZ8091RNA/RND NAND tree input pins have been toggled.

Each KSZ8091RNA/RND NAND tree input pin must cause the TXD1 output pin to toggle high-to-low or low-to-high to indicate a good connection. If the TXD1 pin fails to toggle when the KSZ8091RNA/RND input pin toggles from high to low, the input pin has a fault.

Power Management

The KSZ8091RNA/RND incorporates a number of power-management modes and features that provide methods to consume less energy. These are discussed in the following sections.

Power-Saving Mode

Power-saving mode is used to reduce the transceiver power consumption when the cable is unplugged. It is enabled by writing a '1' to Register 1Fh, Bit [10], and is in effect when Auto-Negotiation mode is enabled and the cable is disconnected (no link).

In this mode, the KSZ8091RNA/RND shuts down all transceiver blocks, except for the transmitter, energy detect, and PLL circuits.

By default, power-saving mode is disabled after power-up.

Energy-Detect Power-Down Mode

Energy-detect power-down (EDPD) mode is used to further reduce transceiver power consumption when the cable is unplugged. It is enabled by writing a '0' to Register 18h, Bit [11], and is in effect when Auto-Negotiation mode is enabled and the cable is disconnected (no link).

EDPD mode works with the PLL off (set by writing a '1' to Register 10h, Bit [4] to automatically turn the PLL off in EDPD mode) to turn off all KSZ8091RNA/RND transceiver blocks except the transmitter and energy-detect circuits.

Power can be reduced further by extending the time interval between transmissions of link pulses to check for the presence of a link partner. The periodic transmission of link pulses is needed to ensure the KSZ8091RNA/RND and its link partner, when operating in the same low-power state and with Auto MDI/MDI-X disabled, can wake up when the cable is connected between them.

By default, EDPD mode is disabled after power-up.

Power-Down Mode

Power-down mode is used to power down the KSZ8091RNA/RND device when it is not in use after power-up. It is enabled by writing a '1' to Register 0h, Bit [11].

In this mode, the KSZ8091RNA/RND disables all internal functions except the MII management interface. The KSZ8091RNA/RND exits (disables) power-down mode after Register 0h, Bit [11] is set back to '0'.

Slow-Oscillator Mode

Slow-oscillator mode is used to disconnect the input reference crystal/clock on XI (Pin 8) and select the on-chip slow oscillator when the KSZ8091RNA/RND device is not in use after power-up. It is enabled by writing a '1' to Register 11h, Bit [5].

Slow-oscillator mode works in conjunction with power-down mode to put the KSZ8091RNA/RND device in the lowest power state, with all internal functions disabled except the MII management interface. To properly exit this mode and return to normal PHY operation, use the following programming sequence:

1. Disable slow-oscillator mode by writing a '0' to Register 11h, Bit [5].
2. Disable power-down mode by writing a '0' to Register 0h, Bit [11].
3. Initiate software reset by writing a '1' to Register 0h, Bit [15].

Energy Efficient Ethernet (EEE)

The KSZ8091RNA/RND implements Energy Efficient Ethernet (EEE) as described in the IEEE Standard 802.3az for 100Base-TX copper signaling by the two differential pairs (analog side) and according to the multisource agreement (MSA) of collaborating Fast Ethernet chip vendors for the RMI (digital side). The MSA agreement is based on the IEEE Standard's EEE implementation for the 100Mbps Media Independent Interface (MII). The IEEE Standard is defined around an EEE-compliant MAC on the host side and an EEE-compliant link partner on the line side that support special signaling associated with EEE. EEE saves power by keeping the AC signal on the copper Ethernet cable at approximately 0V peak-to-peak as often as possible during periods of no traffic activity, while maintaining the link-up status. This is referred to as low-power idle (LPI) mode or state.

During LPI mode, the copper link responds automatically when it receives traffic and resumes normal PHY operation immediately, without blockage of traffic or loss of packet. This involves exiting LPI mode and returning to normal 100Mbps operating mode. Wake-up time is <math><30\mu\text{s}</math> for 100Base-TX.

The LPI state is controlled independently for transmit and receive paths, allowing the LPI state to be active (enabled) for:

- Transmit cable path only
- Receive cable path only
- Both transmit and receive cable paths

The KSZ8091RNA/RND has the EEE function disabled as the power-up default setting. To enable the EEE function for 100Mbps mode, use the following programming sequence:

1. Enable 100Mbps EEE mode advertisement by writing a '1' to MMD Address 7h, Register 3Ch, Bit [1].
2. Restart Auto-Negotiation by writing a '1' to standard Register 0h, Bit [9].

For standard (non-EEE) 10Base-T mode, normal link pulses (NLPs) with long periods of no AC signal transmission are used to maintain the link during the idle period when there is no traffic activity. To save more power, the KSZ8091RNA/RND provides the option to enable 10Base-Te mode, which saves additional power by reducing the transmitted signal amplitude from 2.5V to 1.75V. To enable 10Base-Te mode, write a '1' to standard Register 13h, Bit [4] and write a '0' to MMD Address 1Ch, Register 4h, Bit [13].

During LPI mode, refresh transmissions are used to maintain the link; power savings occur in quiet periods. Approximately every 20ms to 22ms, a refresh transmission of 200μs to 220μs is sent to the link partner. The refresh transmissions and quiet periods are shown in [Figure 9](#).

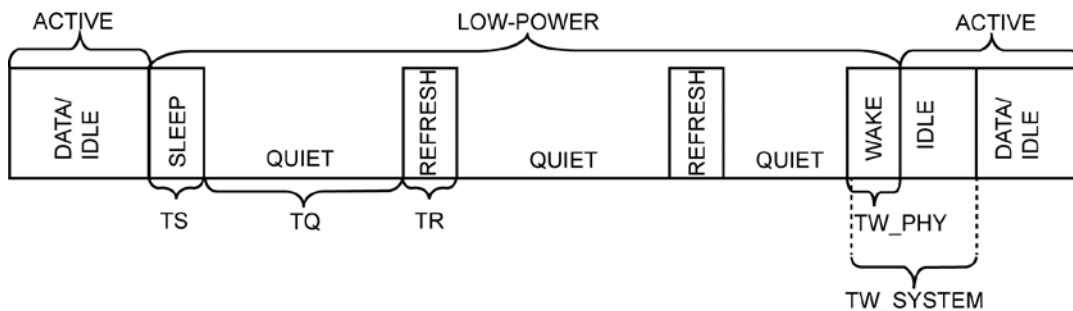

Figure 9. LPI Mode (Refresh Transmissions and Quiet Periods)

Transmit Direction Control (MAC-to-PHY)

The KSZ8091RNA/RND enters LPI mode for the transmit direction when its attached EEE-compliant RMII MAC de-asserts TXEN and sets TXD[1:0] to 01. The KSZ8091RNA/RND remains in the LPI transmit state while the RMII MAC maintains the states of these signals. When the RMII MAC changes any of the TXEN or TX data signals from their LPI state values, the KSZ8091RNA/RND exits the LPI transmit state.

Figure 10 shows the LPI transition for RMII (100Mbps) transmit.

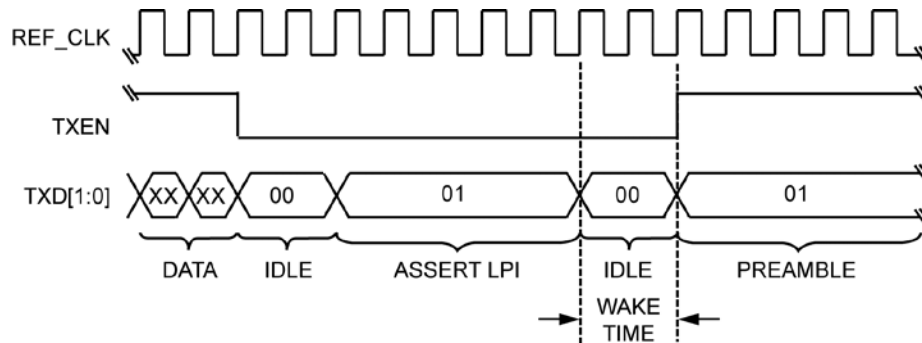

Figure 10. LPI Transition – RMII (100Mbps) Transmit

Receive Direction Control (PHY-to-MAC)

The KSZ8091RNA/RND enters LPI mode for the receive direction when it receives the /P/ code bit pattern (Sleep/Refresh) from its EEE-compliant link partner. It then de-asserts CRS_DV and drives RXD[1:0] to 01. The KSZ8091RNA/RND remains in the LPI receive state while it continues to receive the refresh from its link partner, so it will continue to maintain and drive the LPI output states for the RMII receive signals to inform the attached EEE-compliant RMII MAC that it is in the LPI receive state. When the KSZ8091RNA/RND receives a non /P/ code bit pattern (non-refresh), it exits the LPI receive state and sets the CRS_DV and RX data signals to set a normal frame or normal idle.

Figure 11 shows the LPI transition for RMII (100Mbps) receive.

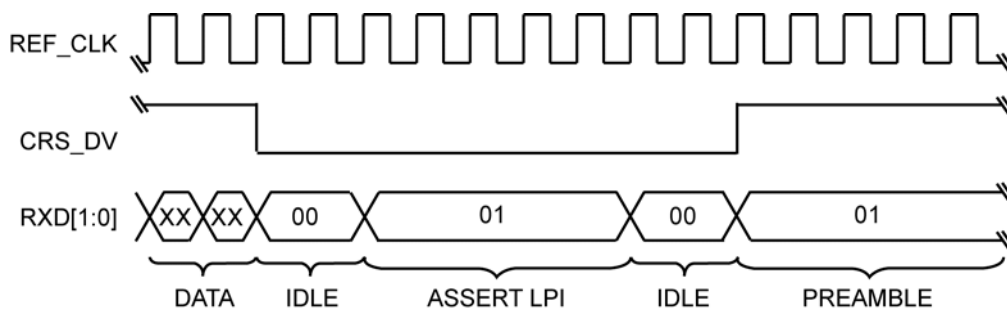

Figure 11. LPI Transition – RMII (100Mbps) Receive

Registers Associated with EEE

The following registers are provided for EEE configuration and management:

- Standard Register 13h – AFE Control 4 (to enable 10Base-T_e mode)
- MMD Address 1h, Register 0h – PMA/PMD Control 1 (to enable LPI)
- MMD Address 1h, Register 1h – PMA/PMD Status 1 (for LPI status)
- MMD Address 7h, Register 3Ch – EEE Advertisement
- MMD Address 7h, Register 3Dh – EEE Link Partner Advertisement
- MMD Address 1Ch, Register 4h – DSP 10Base-T/10Base-T_e Control

Wake-On-LAN

Wake-On-LAN (WOL) is normally a MAC-based function to wake up a host system (for example, an Ethernet end device, such as a PC) that is in standby power mode. Wake-up is triggered by receiving and detecting a special packet (commonly referred to as the “magic packet”) that is sent by the remote link partner. The KSZ8091RNA/RND can perform the same WOL function if the MAC address of its associated MAC device is entered into the KSZ8091RNA/RND PHY Registers for magic-packet detection. When the KSZ8091RNA/RND detects the magic packet, it wakes up the host by driving its power management event (PME) output pin low.

By default, the WOL function is disabled. It is enabled by setting the enabling bit and configuring the associated registers for the selected PME wake-up detection method.

The KSZ8091RNA/RND provides three methods to trigger a PME wake-up:

- Magic-packet detection
- Customized-packet detection
- Link status change detection

Magic-Packet Detection

The magic packet's frame format starts with 6 bytes of 0xFFh and is followed by 16 repetitions of the MAC address of its associated MAC device (local MAC device).

When the magic packet is detected from its link partner, the KSZ8091RNA/RND asserts its PME output pin low.

The following MMD Address 1Fh registers are provided for magic-packet detection:

- Magic-packet detection is enabled by writing a '1' to MMD Address 1Fh, Register 0h, Bit [6]
- The MAC address (for the local MAC device) is written to and stored in MMD Address 1Fh, Registers 19h – 1Bh

The KSZ8091RNA/RND does not generate the magic packet. The magic packet must be provided by the external system.

Customized-Packet Detection

The customized packet has associated register/bit masks to select which byte, or bytes, of the first 64 bytes of the packet to use in the CRC calculation. After the KSZ8091RNA/RND receives the packet from its link partner, the selected bytes for the received packet are used to calculate the CRC. The calculated CRC is compared to the expected CRC value that was previously written to and stored in the KSZ8091RNA/RND PHY Registers. If there is a match, the KSZ8091RNA/RND asserts its PME output pin low.

Four customized packets are provided to support four types of wake-up scenarios. A dedicated set of registers is used to configure and enable each customized packet.

The following MMD Registers are provided for customized-packet detection:

- Each of the four customized packets is enabled via MMD Address 1Fh, Register 0h,
 - Bit [2] // For customized packets, type 0
 - Bit [3] // For customized packets, type 1
 - Bit [4] // For customized packets, type 2
 - Bit [5] // For customized packets, type 3
- Masks to indicate which of the first 64-bytes to use in the CRC calculation are set in:
 - MMD Address 1Fh, Registers 1h – 4h // For customized packets, type 0
 - MMD Address 1Fh, Registers 7h – Ah // For customized packets, type 1
 - MMD Address 1Fh, Registers Dh – 10h // For customized packets, type 2
 - MMD Address 1Fh, Registers 13h – 16h // For customized packets, type 3
- 32-bit expected CRCs are written to and stored in:
 - MMD Address 1Fh, Registers 5h – 6h // For customized packets, type 0
 - MMD Address 1Fh, Registers Bh – Ch // For customized packets, type 1
 - MMD Address 1Fh, Registers 11h – 12h // For customized packets, type 2
 - MMD Address 1Fh, Registers 17h – 18h // For customized packets, type 3

Link Status Change Detection

If link status change detection is enabled, the KSZ8091RNA/RND asserts its PME output pin low whenever there is a link status change, using the following MMD Address 1Fh register bits and their enabled (1) or disabled (0) settings:

- MMD Address 1Fh, Register 0h, Bit [0] // For link-up detection
- MMD Address 1Fh, Register 0h, Bit [1] // For link-down detection

The PME output signal is available on either INTRP/PME_N2 (Pin 18) or LED0/PME_N1 (pin 23), and is enabled using standard Register 16h, Bit [15]. MMD Address 1Fh, Register 0h, Bits [15:14] defines and selects the output functions for Pins 18 and 23.

The PME output is active low and requires a 1k Ω pull-up to the VDDIO supply. When asserted, the PME output is cleared by disabling the register bit that enabled the PME trigger source (magic packet, customized packet, link status change).

Reference Circuit for Power and Ground Connections

The KSZ8091RNA/RND is a single 3.3V supply device with a built-in regulator to supply the 1.2V core. The power and ground connections are shown in Figure 12 and Table 6 for 3.3V VDDIO.

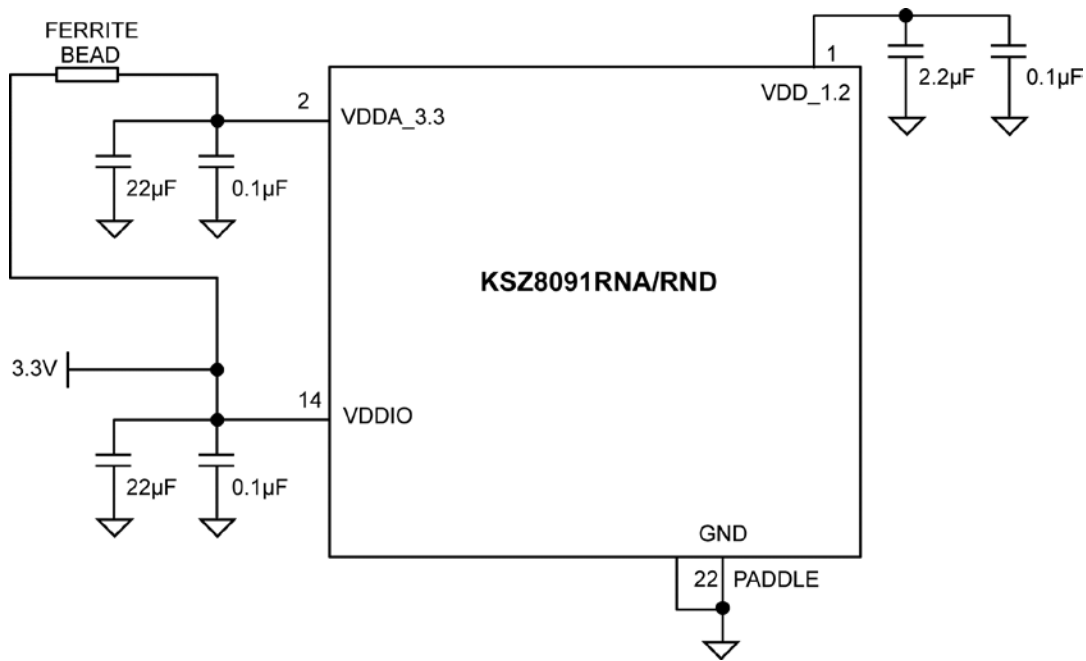

Figure 12. KSZ8091RNA/RND Power and Ground Connections

Table 6. KSZ8091RNA/RND Power Pin Description

Power Pin	Pin Number	Description
VDD_1.2	1	Decouple with 2.2µF and 0.1µF capacitors to ground.
VDDA_3.3	2	Connect to board's 3.3V supply through a ferrite bead. Decouple with 22µF and 0.1µF capacitors to ground.
VDDIO	14	Connect to board's 3.3V supply for 3.3V VDDIO. Decouple with 22µF and 0.1µF capacitors to ground.

Typical Current/Power Consumption

Table 7, Table 8, and Table 9 show typical values for current consumption by the transceiver (VDDA_3.3) and digital I/O (VDDIO) power pins, and typical values for power consumption by the KSZ8091RNA/RND device for the indicated nominal operating voltages. These current and power consumption values include the transmit driver current and on-chip regulator current for the 1.2V core.

Table 7. Typical Current/Power Consumption (VDDA_3.3 = 3.3V, VDDIO = 3.3V)

Transceiver (3.3V), Digital I/Os (3.3V)			
Condition	3.3V Transceiver (VDDA_3.3)	3.3V Digital I/Os (VDDIO)	Total Chip Power
	mA	mA	mW
100Base-TX Link-up (no traffic)	34	12	152
100Base-TX Full-duplex @ 100% utilization	34	13	155
10Base-T Link-up (no traffic)	14	11	82.5
10Base-T Full-duplex @ 100% utilization	30	11	135
EEE 100Mbps Link-up mode (transmit and receive in LPI state with no traffic)	13	10	75.9
Power-saving mode (Reg. 1Fh, Bit [10] = 1)	13	10	75.9
EDPD mode (Reg. 18h, Bit [11] = 0)	10	10	66.0
EDPD mode (Reg. 18h, Bit [11] = 0) and PLL off (Reg. 10h, Bit [4] = 1)	3.77	1.54	17.5
Software power-down mode (Reg. 0h, Bit [11] = 1)	2.59	1.51	13.5
Software power-down mode (Reg. 0h, Bit [11] = 1) and slow-oscillator mode (Reg. 11h, Bit [5] = 1)	1.36	0.45	5.97

Table 8. Typical Current/Power Consumption (VDDA_3.3 = 3.3V, VDDIO = 2.5V)

Transceiver (3.3V), Digital I/Os (2.5V)			
Condition	3.3V Transceiver (VDDA_3.3)	2.5V Digital I/Os (VDDIO)	Total Chip Power
	mA	mA	mW
100Base-TX Link-up (no traffic)	34	11	140
100Base-TX Full-duplex @ 100% utilization	34	12	142
10Base-T Link-up (no traffic)	15	10	74.5
10Base-T Full-duplex @ 100% utilization	27	10	114
EEE 100Mbps Link-up mode (transmit and receive in LPI state with no traffic)	13	10	67.9
Power-saving mode (Reg. 1Fh, Bit [10] = 1)	13	10	67.9
EDPD mode (Reg. 18h, Bit [11] = 0)	11	10	61.3
EDPD mode (Reg. 18h, Bit [11] = 0) and PLL off (Reg. 10h, Bit [4] = 1)	3.55	1.35	15.1
Software power-down mode (Reg. 0h, Bit [11] = 1)	2.29	1.34	10.9
Software power-down mode (Reg. 0h, Bit [11] = 1) and slow-oscillator mode (Reg. 11h, Bit [5] = 1)	1.15	0.29	4.52

Table 9. Typical Current/Power Consumption (VDDA_3.3 = 3.3V, VDDIO = 1.8V)

Transceiver (3.3V), Digital I/Os (1.8V)			
Condition	3.3V Transceiver (VDDA_3.3)	1.8V Digital I/Os (VDDIO)	Total Chip Power
	mA	mA	mW
100Base-TX Link-up (no traffic)	34	11	132
100Base-TX Full-duplex @ 100% utilization	34	12	134
10Base-T Link-up (no traffic)	15	9.0	65.7
10Base-T Full-duplex @ 100% utilization	27	9.0	105
EEE 100Mbps Link-up mode (transmit and receive in LPI state with no traffic)	13	9.0	59.1
Power-saving mode (Reg. 1Fh, Bit [10] = 1)	13	9.0	59.1
EDPD mode (Reg. 18h, Bit [11] = 0)	11	9.0	52.5
EDPD mode (Reg. 18h, Bit [11] = 0) and PLL off (Reg. 10h, Bit [4] = 1)	4.05	1.21	15.5
Software power-down mode (Reg. 0h, Bit [11] =1)	2.79	1.21	11.4
Software power-down mode (Reg. 0h, Bit [11] =1) and slow-oscillator mode (Reg. 11h, Bit [5] =1)	1.65	0.19	5.79

Register Map

The register space within the KSZ8091RNA/RND consists of two distinct areas.

- Standard registers: // Direct register access
- MDIO manageable device (MMD) registers: // Indirect register access

The KSZ8091RNA/RND supports the following standard registers:

Table 10. Standard Registers Supported by KSZ8091RNA/RND

Register Number (Hex)	Description
IEEE-Defined Registers	
0h	Basic Control
1h	Basic Status
2h	PHY Identifier 1
3h	PHY Identifier 2
4h	Auto-Negotiation Advertisement
5h	Auto-Negotiation Link Partner Ability
6h	Auto-Negotiation Expansion
7h	Auto-Negotiation Next Page
8h	Auto-Negotiation Link Partner Next Page Ability
9h – Ch	Reserved
Dh	MMD Access – Control
Eh	MMD Access – Register/Data
Fh	Reserved
Vendor-Specific Registers	
10h	Digital Reserved Control
11h	AFE Control 1
12h	Reserved
13h	AFE Control 4
14h	Reserved
15h	RXER Counter
16h	Operation Mode Strap Override
17h	Operation Mode Strap Status
18h	Expanded Control
19h – 1Ah	Reserved
1Bh	Interrupt Control/Status
1Ch	Reserved
1Dh	LinkMD Cable Diagnostic
1Eh	PHY Control 1
1Fh	PHY Control 2

The KSZ8091RNA/RND supports the following MMD device addresses and their associated register addresses, which make up the indirect MMD registers:

Table 11. MMD Registers Supported by KSZ8091RNA/RND

Device Address (Hex)	Register Address (Hex)	Description
1h	0h	PMA/PMD Control 1
	1h	PMA/PMD Status 1
7h	3Ch	EEE Advertisement
	3Dh	EEE Link Partner Advertisement
1Ch	4h	DSP 10Base-T/10Base-Te Control
1Fh	0h	Wake-On-LAN – Control
	1h	Wake-On-LAN – Customized Packet, Type 0, Mask 0
	2h	Wake-On-LAN – Customized Packet, Type 0, Mask 1
	3h	Wake-On-LAN – Customized Packet, Type 0, Mask 2
	4h	Wake-On-LAN – Customized Packet, Type 0, Mask 3
	5h	Wake-On-LAN – Customized Packet, Type 0, Expected CRC 0
	6h	Wake-On-LAN – Customized Packet, Type 0, Expected CRC 1
	7h	Wake-On-LAN – Customized Packet, Type 1, Mask 0
	8h	Wake-On-LAN – Customized Packet, Type 1, Mask 1
	9h	Wake-On-LAN – Customized Packet, Type 1, Mask 2
	Ah	Wake-On-LAN – Customized Packet, Type 1, Mask 3
	Bh	Wake-On-LAN – Customized Packet, Type 1, Expected CRC 0
	Ch	Wake-On-LAN – Customized Packet, Type 1, Expected CRC 1
	Dh	Wake-On-LAN – Customized Packet, Type 2, Mask 0
	Eh	Wake-On-LAN – Customized Packet, Type 2, Mask 1
	Fh	Wake-On-LAN – Customized Packet, Type 2, Mask 2
	10h	Wake-On-LAN – Customized Packet, Type 2, Mask 3
	11h	Wake-On-LAN – Customized Packet, Type 2, Expected CRC 0
	12h	Wake-On-LAN – Customized Packet, Type 2, Expected CRC 1
	13h	Wake-On-LAN – Customized Packet, Type 3, Mask 0
	14h	Wake-On-LAN – Customized Packet, Type 3, Mask 1
	15h	Wake-On-LAN – Customized Packet, Type 3, Mask 2
	16h	Wake-On-LAN – Customized Packet, Type 3, Mask 3
	17h	Wake-On-LAN – Customized Packet, Type 3, Expected CRC 0
	18h	Wake-On-LAN – Customized Packet, Type 3, Expected CRC 1
	19h	Wake-On-LAN – Magic Packet, MAC-DA-0
1Ah	Wake-On-LAN – Magic Packet, MAC-DA-1	
1Bh	Wake-On-LAN – Magic Packet, MAC-DA-2	

Standard Registers

Standard registers provide direct read/write access to a 32-register address space, as defined in Clause 22 of the IEEE 802.3 Specification. Within this address space, the first 16 registers (Registers 0h to Fh) are defined according to the IEEE specification, while the remaining 16 registers (Registers 10h to 1Fh) are defined specific to the PHY vendor.

IEEE-Defined Registers – Descriptions

Address	Name	Description	Mode ⁽⁶⁾	Default
Register 0h – Basic Control				
0.15	Reset	1 = Software reset 0 = Normal operation This bit is self-cleared after a '1' is written to it.	RW/SC	0
0.14	Loopback	1 = Loopback mode 0 = Normal operation	RW	0
0.13	Speed Select	1 = 100Mbps 0 = 10Mbps This bit is ignored if Auto-Negotiation is enabled (Register 0.12 = 1).	RW	Set by the ANEN_SPEED strapping pin. See the Strapping Options section for details.
0.12	Auto-Negotiation Enable	1 = Enable Auto-Negotiation process 0 = Disable Auto-Negotiation process If enabled, the Auto-Negotiation result overrides the settings in Registers 0.13 and 0.8.	RW	Set by the ANEN_SPEED strapping pin. See the Strapping Options section for details.
0.11	Power-Down	1 = Power-down mode 0 = Normal operation If software reset (Register 0.15) is used to exit power-down mode (Register 0.11 = 1), two software reset writes (Register 0.15 = 1) are required. The first write clears power-down mode; the second write resets the chip and re-latches the pin strapping pin values.	RW	0
0.10	Isolate	1 = Electrical isolation of PHY from RMII 0 = Normal operation	RW	0
0.9	Restart Auto-Negotiation	1 = Restart Auto-Negotiation process 0 = Normal operation. This bit is self-cleared after a '1' is written to it.	RW/SC	0
0.8	Duplex Mode	1 = Full-duplex 0 = Half-duplex	RW	1
0.7	Collision Test	1 = Enable COL test 0 = Disable COL test	RW	0
0.6:0	Reserved	Reserved	RO	000_0000

Note:

6. RW = Read/Write.
RO = Read only.
SC = Self-cleared.
LH = Latch high.
LL = Latch low.

IEEE-Defined Registers – Descriptions (Continued)

Address	Name	Description	Mode ⁽⁶⁾	Default
Register 1h – Basic Status				
1.15	100Base-T4	1 = T4 capable 0 = Not T4 capable	RO	0
1.14	100Base-TX Full-Duplex	1 = Capable of 100Mbps full-duplex 0 = Not capable of 100Mbps full-duplex	RO	1
1.13	100Base-TX Half-Duplex	1 = Capable of 100Mbps half-duplex 0 = Not capable of 100Mbps half-duplex	RO	1
1.12	10Base-T Full-Duplex	1 = Capable of 10Mbps full-duplex 0 = Not capable of 10Mbps full-duplex	RO	1
1.11	10Base-T Half-Duplex	1 = Capable of 10Mbps half-duplex 0 = Not capable of 10Mbps half-duplex	RO	1
1.10:7	Reserved	Reserved	RO	000_0
1.6	No Preamble	1 = Preamble suppression 0 = Normal preamble	RO	1
1.5	Auto-Negotiation Complete	1 = Auto-Negotiation process completed 0 = Auto-Negotiation process not completed	RO	0
1.4	Remote Fault	1 = Remote fault 0 = No remote fault	RO/LH	0
1.3	Auto-Negotiation Ability	1 = Can perform Auto-Negotiation 0 = Cannot perform Auto-Negotiation	RO	1
1.2	Link Status	1 = Link is up 0 = Link is down	RO/LL	0
1.1	Jabber Detect	1 = Jabber detected 0 = Jabber not detected (default is low)	RO/LH	0
1.0	Extended Capability	1 = Supports extended capability registers	RO	1
Register 2h – PHY Identifier 1				
2.15:0	PHY ID Number	Assigned to the 3rd through 18th bits of the Organizationally Unique Identifier (OUI). KENDIN Communication's OUI is 0010A1 (hex).	RO	0022h
Register 3h – PHY Identifier 2				
3.15:10	PHY ID Number	Assigned to the 19th through 24th bits of the Organizationally Unique Identifier (OUI). KENDIN Communication's OUI is 0010A1 (hex).	RO	0001_01
3.9:4	Model Number	Six-bit manufacturer's model number	RO	01_0110
3.3:0	Revision Number	Four-bit manufacturer's revision number	RO	Indicates silicon revision

IEEE-Defined Registers – Descriptions (Continued)

Address	Name	Description	Mode ⁽⁶⁾	Default
Register 4h – Auto-Negotiation Advertisement				
4.15	Next Page	1 = Next page capable 0 = No next page capability	RW	0
4.14	Reserved	Reserved	RO	0
4.13	Remote Fault	1 = Remote fault supported 0 = No remote fault	RW	0
4.12	Reserved	Reserved	RO	0
4.11:10	Pause	[00] = No pause [10] = Asymmetric pause [01] = Symmetric pause [11] = Asymmetric and symmetric pause	RW	00
4.9	100Base-T4	1 = T4 capable 0 = No T4 capability	RO	0
4.8	100Base-TX Full-Duplex	1 = 100Mbps full-duplex capable 0 = No 100Mbps full-duplex capability	RW	Set by the ANEN_SPEED strapping pin. See the Strapping Options section for details.
4.7	100Base-TX Half-Duplex	1 = 100Mbps half-duplex capable 0 = No 100Mbps half-duplex capability	RW	Set by the ANEN_SPEED strapping pin. See the Strapping Options section for details.
4.6	10Base-T Full-Duplex	1 = 10Mbps full-duplex capable 0 = No 10Mbps full-duplex capability	RW	1
4.5	10Base-T Half-Duplex	1 = 10Mbps half-duplex capable 0 = No 10Mbps half-duplex capability	RW	1
4.4:0	Selector Field	[00001] = IEEE 802.3	RW	0_0001
Register 5h – Auto-Negotiation Link Partner Ability				
5.15	Next Page	1 = Next page capable 0 = No next page capability	RO	0
5.14	Acknowledge	1 = Link code word received from partner 0 = Link code word not yet received	RO	0
5.13	Remote Fault	1 = Remote fault detected 0 = No remote fault	RO	0
5.12	Reserved	Reserved	RO	0
5.11:10	Pause	[00] = No pause [10] = Asymmetric pause [01] = Symmetric pause [11] = Asymmetric and symmetric pause	RO	00
5.9	100Base-T4	1 = T4 capable 0 = No T4 capability	RO	0

IEEE-Defined Registers – Descriptions (Continued)

Address	Name	Description	Mode ⁽⁶⁾	Default
5.8	100Base-TX Full-Duplex	1 = 100Mbps full-duplex capable 0 = No 100Mbps full-duplex capability	RO	0
5.7	100Base-TX Half-Duplex	1 = 100Mbps half-duplex capable 0 = No 100Mbps half-duplex capability	RO	0
5.6	10Base-T Full-Duplex	1 = 10Mbps full-duplex capable 0 = No 10Mbps full-duplex capability	RO	0
5.5	10Base-T Half-Duplex	1 = 10Mbps half-duplex capable 0 = No 10Mbps half-duplex capability	RO	0
5.4:0	Selector Field	[00001] = IEEE 802.3	RO	0_0001
Register 6h – Auto-Negotiation Expansion				
6.15:5	Reserved	Reserved	RO	0000_0000_000
6.4	Parallel Detection Fault	1 = Fault detected by parallel detection 0 = No fault detected by parallel detection	RO/LH	0
6.3	Link Partner Next Page Able	1 = Link partner has next page capability 0 = Link partner does not have next page capability	RO	0
6.2	Next Page Able	1 = Local device has next page capability 0 = Local device does not have next page capability	RO	1
6.1	Page Received	1 = New page received 0 = New page not received yet	RO/LH	0
6.0	Link Partner Auto-Negotiation Able	1 = Link partner has Auto-Negotiation capability 0 = Link partner does not have Auto-Negotiation capability	RO	0
Register 7h – Auto-Negotiation Next Page				
7.15	Next Page	1 = Additional next pages will follow 0 = Last page	RW	0
7.14	Reserved	Reserved	RO	0
7.13	Message Page	1 = Message page 0 = Unformatted page	RW	1
7.12	Acknowledge2	1 = Will comply with message 0 = Cannot comply with message	RW	0
7.11	Toggle	1 = Previous value of transmitted link code word equal to logic 0 0 = Previous value of transmitted link code word equal to logic 1	RO	0
7.10:0	Message Field	11-bit wide field to encode 2048 messages	RW	000_0000_0001

IEEE-Defined Registers – Descriptions (Continued)

Address	Name	Description	Mode ⁽⁶⁾	Default
Register 8h – Auto-Negotiation Link Partner Next Page Ability				
8.15	Next Page	1 = Additional next pages will follow 0 = Last page	RO	0
8.14	Acknowledge	1 = Successful receipt of link word 0 = No successful receipt of link word	RO	0
8.13	Message Page	1 = Message page 0 = Unformatted page	RO	0
8.12	Acknowledge2	1 = Can act on the information 0 = Cannot act on the information	RO	0
8.11	Toggle	1 = Previous value of transmitted link code word equal to logic 0 0 = Previous value of transmitted link code word equal to logic 1	RO	0
8.10:0	Message Field	11-bit wide field to encode 2048 messages	RO	000_0000_0000
Register Dh – MMD Access – Control				
D.15:14	MMD – Operation Mode	For the selected MMD Device Address (Bits [4:0] of this register), these two bits select one of the following register or data operations and the usage for MMD Access – Register/Data (Reg. Eh). 00 = Register 01 = Data, no post increment 10 = Data, post increment on reads and writes 11 = Data, post increment on writes only	RW	00
D.13:5	Reserved	Reserved	RW	00_0000_000
D.4:0	MMD – Device Address	These five bits set the MMD device address.	RW	0_0000
Register Eh – MMD Access – Register/Data				
E.15:0	MMD – Register/Data	For the selected MMD Device Address (Reg. Dh, Bits [4:0]), When Reg. Dh, Bits [15:14] = 00, this register contains the read/write register address for the MMD Device Address. Otherwise, this register contains the read/write data value for the MMD Device Address and its selected register address. See also Reg. Dh, Bits [15:14], for descriptions of post increment reads and writes of this register for data operation.	RW	0000_0000_0000_0000

Vendor-Specific Registers – Descriptions

Address	Name	Description	Mode ⁽⁷⁾	Default
Register 10h – Digital Reserved Control				
10.15:5	Reserved	Reserved	RW	0000_0000_000
10.4	PLL Off	1 = Turn PLL off automatically in EDPD mode 0 = Keep PLL on in EDPD mode. See also Register 18h, Bit [11] for EDPD mode	RW	0
10.3:0	Reserved	Reserved	RW	0000
Register 11h – AFE Control 1				
11.15:6	Reserved	Reserved	RW	0000_0000_00
11.5	Slow-Oscillator Mode Enable	Slow-oscillator mode is used to disconnect the input reference crystal/clock on the XI pin and select the on-chip slow oscillator when the KSZ8091RNA/RND device is not in use after power-up. 1 = Enable 0 = Disable This bit automatically sets software power-down to the analog side when enabled.	RW	0
11.4:0	Reserved	Reserved	RW	0_0000
Register 13h – AFE Control 4				
13.15:5	Reserved	Reserved	RW	0000_0000_000
13.4	10Base-Te Mode	1 = EEE 10Base-Te (1.75V TX amplitude) and also set MMD Address 1Ch, Register 4h, Bit [13] to '0'. 0 = Standard 10Base-T (2.5V TX amplitude) and also set MMD Address 1Ch, Register 4h, Bit [13] to '1'.	RW	0
13.3:0	Reserved	Reserved	RW	0000
Register 15h – RXER Counter				
15.15:0	RXER Counter	Receive error counter for symbol error frames	RO/SC	0000h
Register 16h – Operation Mode Strap Override				
16.15	PME Enable	PME for Wake-On-LAN 1 = Enable 0 = Disable This bit works in conjunction with MMD Address 1Fh, Reg. 0h, Bits [15:14] to define the output for Pins 18 and 23.	RW	Set by the PME_EN strapping pin. See the Strapping Options section for details.
16.14:11	Reserved	Reserved	RW	000_0
16.10	Reserved	Reserved	RO	0
16.9	B-CAST_OFF Override	1 = Override to disable broadcast (default setting) for PHY Address 0 If bit is '1', PHY Address 0 is non-broadcast.	RW	0
16.8:7	Reserved	Reserved	RW	0_0

Note:

7. RW = Read/Write.
RO = Read only.
SC = Self-cleared.

Vendor-Specific Registers – Descriptions (Continued)

Address	Name	Description	Mode ⁽⁷⁾	Default
16.6	RMII B-to-B Override	1 = Override to enable RMII Back-to-Back mode (also set Bit 1 of this register to '1')	RW	0
16.5	NAND Tree Override	1 = Override to enable NAND Tree mode	RW	0
16.4:2	Reserved	Reserved	RW	0_00
16.1	RMII Override	1 = Override to enable RMII mode	RW	1
16.0	Reserved	Reserved	RW	0
Register 17h – Operation Mode Strap Status				
17.15	Reserved	Reserved	RO	
17.14:13	PHYAD[1:0] Strap-In Status	[00] = Strap to PHY Address 00000b (0h) [11] = Strap to PHY Address 00011b (3h) The KSZ8091RNA/RND supports PHY addresses 0h and 3h only.	RO	Set by the PHYAD[1:0] strapping pin. See the Strapping Options section for details.
17.12:2	Reserved	Reserved	RO	
17.1	RMII Strap-In Status	1 = Strap to RMII mode	RO	
17.0	Reserved	Reserved	RO	
Register 18h – Expanded Control				
18.15:12	Reserved	Reserved	RW	0000
18.11	EDPD Disabled	Energy-detect power-down mode 1 = Disable 0 = Enable See also Register 10h, Bit [4] for PLL off.	RW	1
18.10:0	Reserved	Reserved	RW	000_0000_0001
Register 1Bh – Interrupt Control/Status				
1B.15	Jabber Interrupt Enable	1 = Enable jabber interrupt 0 = Disable jabber interrupt	RW	0
1B.14	Receive Error Interrupt Enable	1 = Enable receive error interrupt 0 = Disable receive error interrupt	RW	0
1B.13	Page Received Interrupt Enable	1 = Enable page received interrupt 0 = Disable page received interrupt	RW	0
1B.12	Parallel Detect Fault Interrupt Enable	1 = Enable parallel detect fault interrupt 0 = Disable parallel detect fault interrupt	RW	0
1B.11	Link Partner Acknowledge Interrupt Enable	1 = Enable link partner acknowledge interrupt 0 = Disable link partner acknowledge interrupt	RW	0
1B.10	Link-Down Interrupt Enable	1 = Enable link-down interrupt 0 = Disable link-down interrupt	RW	0

Vendor-Specific Registers – Descriptions (Continued)

Address	Name	Description	Mode ⁽⁷⁾	Default
1B.9	Remote Fault Interrupt Enable	1 = Enable remote fault interrupt 0 = Disable remote fault interrupt	RW	0
1B.8	Link-Up Interrupt Enable	1 = Enable link-up interrupt 0 = Disable link-up interrupt	RW	0
1B.7	Jabber Interrupt	1 = Jabber occurred 0 = Jabber did not occur	RO/SC	0
1B.6	Receive Error Interrupt	1 = Receive error occurred 0 = Receive error did not occur	RO/SC	0
1B.5	Page Receive Interrupt	1 = Page receive occurred 0 = Page receive did not occur	RO/SC	0
1B.4	Parallel Detect Fault Interrupt	1 = Parallel detect fault occurred 0 = Parallel detect fault did not occur	RO/SC	0
1B.3	Link Partner Acknowledge Interrupt	1 = Link partner acknowledge occurred 0 = Link partner acknowledge did not occur	RO/SC	0
1B.2	Link-Down Interrupt	1 = Link-down occurred 0 = Link-down did not occur	RO/SC	0
1B.1	Remote Fault Interrupt	1 = Remote fault occurred 0 = Remote fault did not occur	RO/SC	0
1B.0	Link-Up Interrupt	1 = Link-up occurred 0 = Link-up did not occur	RO/SC	0
Register 1Dh – LinkMD Cable Diagnostic				
1D.15	Cable Diagnostic Test Enable	1 = Enable cable diagnostic test. After test has completed, this bit is self-cleared. 0 = Indicates cable diagnostic test (if enabled) has completed and the status information is valid for read.	RW/SC	0
1D.14:13	Cable Diagnostic Test Result	[00] = Normal condition [01] = Open condition has been detected in cable [10] = Short condition has been detected in cable [11] = Cable diagnostic test has failed	RO	00
1D.12	Short Cable Short Indicator	1 = A short cable (<10 meter) short condition has been detected by LinkMD	RO	0
1D.11:9	Reserved	Reserved	RW	000
1D.8:0	Cable Fault Counter	Distance to fault	RO	0_0000_0000

Vendor-Specific Registers – Descriptions (Continued)

Address	Name	Description	Mode ⁽⁷⁾	Default
Register 1Eh – PHY Control 1				
1E.15:10	Reserved	Reserved	RO	0000_00
1E.9	Enable Pause (Flow Control)	1 = Flow control capable 0 = No flow control capability	RO	0
1E.8	Link Status	1 = Link is up 0 = Link is down	RO	0
1E.7	Polarity Status	1 = Polarity is reversed 0 = Polarity is not reversed	RO	
1E.6	Reserved	Reserved	RO	0
1E.5	MDI/MDI-X State	1 = MDI-X 0 = MDI	RO	
1E.4	Energy Detect	1 = Signal present on receive differential pair 0 = No signal detected on receive differential pair	RO	0
1E.3	PHY Isolate	1 = PHY in isolate mode 0 = PHY in normal operation	RW	0
1E.2:0	Operation Mode Indication	[000] = Still in Auto-Negotiation [001] = 10Base-T half-duplex [010] = 100Base-TX half-duplex [011] = Reserved [100] = Reserved [101] = 10Base-T full-duplex [110] = 100Base-TX full-duplex [111] = Reserved	RO	000
Register 1Fh – PHY Control 2				
1F.15	HP_MDIX	1 = HP Auto MDI/MDI-X mode 0 = Micrel Auto MDI/MDI-X mode	RW	1
1F.14	MDI/MDI-X Select	When Auto MDI/MDI-X is disabled, 1 = MDI-X mode Transmit on RXP,RXM (pins 4, 3) and Receive on TXP,TXM (pins 6, 5) 0 = MDI mode Transmit on TXP,TXM (pins 6, 5) and Receive on RXP,RXM (pins 4, 3)	RW	0
1F.13	Pair Swap Disable	1 = Disable Auto MDI/MDI-X 0 = Enable Auto MDI/MDI-X	RW	0
1F.12	Reserved	Reserved	RW	0

Vendor-Specific Registers – Descriptions (Continued)

Address	Name	Description	Mode ⁽⁷⁾	Default
1F.11	Force Link	1 = Force link pass 0 = Normal link operation This bit bypasses the control logic and allows the transmitter to send a pattern even if there is no link.	RW	0
1F.10	Power Saving	1 = Enable power saving 0 = Disable power saving	RW	0
1F.9	Interrupt Level	1 = Interrupt pin active high 0 = Interrupt pin active low	RW	0
1F.8	Enable Jabber	1 = Enable jabber counter 0 = Disable jabber counter	RW	1
1F.7	RMII Reference Clock Select	1 = For KSZ8091RNA, clock input to XI (Pin 8) is 50MHz for RMII – 50MHz Clock Mode. For KSZ8091RND, clock input to XI (Pin 8) is 25MHz for RMII – 25MHz Clock Mode. 0 = For KSZ8091RNA, clock input to XI (Pin 8) is 25MHz for RMII – 25MHz Clock Mode. For KSZ8091RND, clock input to XI (Pin 8) is 50MHz for RMII – 50MHz Clock Mode.	RW	0
1F.6	Reserved	Reserved	RW	0
1F.5:4	LED Mode	[00] = LED0: Link/Activity [01] = LED0: Link [10], [11] = Reserved	RW	00
1F.3	Disable Transmitter	1 = Disable transmitter 0 = Enable transmitter	RW	0
1F.2	Remote Loopback	1 = Remote (analog) loopback is enabled 0 = Normal mode	RW	0
1F.1	Reserved	Reserved	RW	0
1F.0	Disable Data Scrambling	1 = Disable scrambler 0 = Enable scrambler	RW	0

MMD Registers

MMD registers provide indirect read/write access to up to 32 MMD Device Addresses with each device supporting up to 65,536 16-bit registers, as defined in Clause 22 of the IEEE 802.3 Specification. The KSZ8091RNA/RND, however, uses only a small fraction of the available registers. See the [Register Map](#) section for a list of supported MMD device addresses and their associated register addresses.

The following two standard registers serve as the portal registers to access the indirect MMD registers.

- Standard Register Dh – MMD Access – Control
- Standard Register Eh – MMD Access – Register/Data

Table 12. Portal Registers (Access to Indirect MMD Registers)

Address	Name	Description	Mode	Default
Register Dh – MMD Access – Control				
D.15:14	MMD – Operation Mode	For the selected MMD Device Address (Bits [4:0] of this register), these two bits select one of the following register or data operations and the usage for MMD Access – Register/Data (Reg. Eh). 00 = Register 01 = Data, no post increment 10 = Data, post increment on reads and writes 11 = Data, post increment on writes only	RW	00
D.13:5	Reserved	Reserved	RW	00_0000_000
D.4:0	MMD – Device Address	These five bits set the MMD device address.	RW	0_0000
Register Eh – MMD Access – Register/Data				
E.15:0	MMD – Register/Data	For the selected MMD Device Address (Reg. Dh, Bits [4:0]), When Reg. Dh, Bits [15:14] = 00, this register contains the read/write register address for the MMD Device Address. Otherwise, this register contains the read/write data value for the MMD Device Address and its selected register address. See also Register Dh, Bits [15:14] descriptions for post increment reads and writes of this register for data operation.	RW	0000_0000_0000_0000

Examples:

MMD Register Write

Write MMD – Device Address 1Fh, Register 0h = 0001h to enable link-up detection to trigger PME for WoL.

1. Write Register Dh with 001Fh // Set up register address for MMD – Device Address 1Fh.
2. Write Register Eh with 0000h // Select Register 0h of MMD – Device Address 1Fh.
3. Write Register Dh with 401Fh // Select register data for MMD – Device Address 1Fh, Register 0h.
4. Write Register Eh with 0001h // Write value 0001h to MMD – Device Address 1Fh, Register 0h.

MMD Register Read

Read MMD – Device Address 1Fh, Register 19h – 1Bh for the magic packet's MAC address

1. Write Register Dh with 001Fh // Set up register address for MMD – Device Address 1Fh.
2. Write Register Eh with 0019h // Select Register 19h of MMD – Device Address 1Fh.
3. Write Register Dh with 801Fh // Select register data for MMD – Device Address 1Fh, Register 19h
// with post increments
4. Read Register Eh // Read data in MMD – Device Address 1Fh, Register 19h.
5. Read Register Eh // Read data in MMD – Device Address 1Fh, Register 1Ah.
6. Read Register Eh // Read data in MMD – Device Address 1Fh, Register 1Bh.

MMD Registers – Descriptions

Address	Name	Description	Mode ⁽⁸⁾	Default
MMD Address 1h, Register 0h – PMA/PMD Control 1				
1.0.15:13	Reserved	Reserved	RW	000
1.0.12	LPI enable	Lower Power Idle enable	RW	0
1.0.11:0	Reserved	Reserved	RW	0000_0000_0000
MMD Address 1h, Register 1h – PMA/PMD Status 1				
1.1.15:9	Reserved	Reserved	RO	0000_000
1.1.8	LPI State Entered	1 = PMA/PMD has entered LPI state 0 = PMA/PMD has not entered LPI state	RO/LH	0
1.1.7:4	Reserved	Reserved	RO	0000
1.1.3	LPI State Indication	1 = PMA/PMD is currently in LPI state 0 = PMA/PMD is currently not in LPI state	RO	0
1.1.2:0	Reserved	Reserved	RO	000
MMD Address 7h, Register 3Ch – EEE Advertisement				
7.3C.15:3	Reserved	Reserved	RO	0000_0000_0000_0
7.3C.2	1000Base-T EEE Capable	0 = 1000Mbps EEE is not supported	RO	0
7.3C.1	100Base-TX EEE Capable	1 = 100Mbps EEE capable 0 = No 100Mbps EEE capability This bit is set to '0' as the default after power-up or reset. Set this bit to '1' to enable 100Mbps EEE mode.	RW	0
7.3C.0	Reserved	Reserved	RO	0
MMD Address 7h, Register 3Dh – EEE Link Partner Advertisement				
7.3D.15:3	Reserved	Reserved	RO	0000_0000_0000_0
7.3D.2	1000Base-T EEE Capable	1 = 1000Mbps EEE capable 0 = No 1000Mbps EEE capability	RO	0
7.3D.1	100Base-TX EEE Capable	1 = 100Mbps EEE capable 0 = No 100Mbps EEE capability	RO	0
7.3D.0	Reserved	Reserved	RO	0
MMD Address 1Ch, Register 4h – DSP 10Base-T/10Base-Te Control				
1C.4.15	Reserved	Reserved	RW	0
1C.4.14	Reserved	Reserved	RO	0
1C.4.13	DSP 10Base-T/10Base-Te Mode Select	1 = Standard 10Base-T (2.5V TX amplitude) and also set Standard Register 13h, Bit [4] to '0'. 0 = EEE 10Base-Te (1.75V TX amplitude) and also set Standard Register 13h, Bit [4] to '1'.	RW	1
1C.4.12	Reserved	Reserved	RW	0
1C.4.11:0	Reserved	Reserved	RO	0000_0000_0000

Note:

8. RW = Read/Write.
RO = Read only.
LH = Latch high.

MMD Registers – Descriptions (Continued)

Address	Name	Description	Mode ⁽⁸⁾	Default
MMD Address 1Fh, Register 0h – Wake-On-LAN – Control				
1F.0.15:14	PME Output Select	<p>These two bits work in conjunction with Reg. 16h, Bit [15] for PME enable to define the output for Pins 18 and 23.</p> <p>INTRP/PME_N2 (Pin 18)</p> <p>00 = INTRP output 01 = PME_N2 output 10 = INTRP and PME_N2 output 11 = Reserved</p> <p>LED0/PME_N1 (Pin 23)</p> <p>00 = PME_N1 output 01 = LED0 output 10 = LED0 output 11 = PME_N1 output</p>	RW	00
1F.0.13:7	Reserved	Reserved	RO	00_0000_0
1F.0.6	Magic Packet Detect Enable	1 = Enable magic-packet detection 0 = Disable magic-packet detection	RW	0
1F.0.5	Custom-Packet Type 3 Detect Enable	1 = Enable custom-packet, Type 3 detection 0 = Disable custom-packet, Type 3 detection	RW	0
1F.0.4	Custom-Packet Type 2 Detect Enable	1 = Enable custom-packet, Type 2 detection 0 = Disable custom-packet, Type 2 detection	RW	0
1F.0.3	Custom-Packet Type 1 Detect Enable	1 = Enable custom-packet, Type 1 detection 0 = Disable custom-packet, Type 1 detection	RW	0
1F.0.2	Custom-Packet Type 0 Detect Enable	1 = Enable custom-packet, Type 0 detection 0 = Disable custom-packet, Type 0 detection	RW	0
1F.0.1	Link-Down Detect Enable	1 = Enable link-down detection 0 = Disable link-down detection	RW	0
1F.0.0	Link-Up Detect Enable	1 = Enable link-up detection 0 = Disable link-up detection	RW	0

MMD Registers – Descriptions (Continued)

Address	Name	Description	Mode ⁽⁸⁾	Default
MMD Address 1Fh, Register 1h – Wake-On-LAN – Customized Packet, Type 0, Mask 0 MMD Address 1Fh, Register 7h – Wake-On-LAN – Customized Packet, Type 1, Mask 0 MMD Address 1Fh, Register Dh – Wake-On-LAN – Customized Packet, Type 2, Mask 0 MMD Address 1Fh, Register 13h – Wake-On-LAN – Customized Packet, Type 3, Mask 0				
1F.1.15:0 1F.7.15:0 1F.D.15:0 1F.13.15:0	Custom Packet Type X Mask 0	This register selects the bytes in the first 16 bytes of the packet (bytes 1 thru 16) that will be used for CRC calculation. For each bit in this register, 1 = Byte is selected for CRC calculation 0 = Byte is not selected for CRC calculation The register-bit to packet-byte mapping is as follows: Bit [15] : byte-16 ... : ... Bit [1] : byte-2 Bit [0] : byte-1	RW	0000_0000_0000_0000
MMD Address 1Fh, Register 2h – Wake-On-LAN – Customized Packet, Type 0, Mask 1 MMD Address 1Fh, Register 8h – Wake-On-LAN – Customized Packet, Type 1, Mask 1 MMD Address 1Fh, Register Eh – Wake-On-LAN – Customized Packet, Type 2, Mask 1 MMD Address 1Fh, Register 14h – Wake-On-LAN – Customized Packet, Type 3, Mask 1				
1F.2.15:0 1F.8.15:0 1F.E.15:0 1F.14.15:0	Custom Packet Type X Mask 1	This register selects the bytes in the second 16 bytes of the packet (bytes 17 thru 32) that will be used for CRC calculation. For each bit in this register, 1 = Byte is selected for CRC calculation 0 = Byte is not selected for CRC calculation The register-bit to packet-byte mapping is as follows: Bit [15] : byte-32 ... : ... Bit [1] : byte-18 Bit [0] : byte-17	RW	0000_0000_0000_0000

MMD Registers – Descriptions (Continued)

Address	Name	Description	Mode ⁽⁸⁾	Default
MMD Address 1Fh, Register 3h – Wake-On-LAN – Customized Packet, Type 0, Mask 2				
MMD Address 1Fh, Register 9h – Wake-On-LAN – Customized Packet, Type 1, Mask 2				
MMD Address 1Fh, Register Fh – Wake-On-LAN – Customized Packet, Type 2, Mask 2				
MMD Address 1Fh, Register 15h – Wake-On-LAN – Customized Packet, Type 3, Mask 2				
1F.3.15:0 1F.9.15:0 1F.F.15:0 1F.15.15:0	Custom Packet Type X Mask 2	<p>This register selects the bytes in the third 16 bytes of the packet (bytes 33 thru 48) that will be used for CRC calculation.</p> <p>For each bit in this register, 1 = Byte is selected for CRC calculation 0 = Byte is not selected for CRC calculation</p> <p>The register-bit to packet-byte mapping is as follows:</p> <p>Bit [15] : byte-48 ... : ... Bit [1] : byte-34 Bit [0] : byte-33</p>	RW	0000_0000_0000_0000
MMD Address 1Fh, Register 4h – Wake-On-LAN – Customized Packet, Type 0, Mask 3				
MMD Address 1Fh, Register Ah – Wake-On-LAN – Customized Packet, Type 1, Mask 3				
MMD Address 1Fh, Register 10h – Wake-On-LAN – Customized Packet, Type 2, Mask 3				
MMD Address 1Fh, Register 16h – Wake-On-LAN – Customized Packet, Type 3, Mask 3				
1F.4.15:0 1F.A.15:0 1F.10.15:0 1F.16.15:0	Custom Packet Type X Mask 3	<p>This register selects the bytes in the fourth 16 bytes of the packet (bytes 49 thru 64) that will be used for CRC calculation.</p> <p>For each bit in this register, 1 = Byte is selected for CRC calculation 0 = Byte is not selected for CRC calculation</p> <p>The register-bit to packet-byte mapping is as follows:</p> <p>Bit [15] : byte-64 ... : ... Bit [1] : byte-50 Bit [0] : byte-49</p>	RW	0000_0000_0000_0000
MMD Address 1Fh, Register 5h – Wake-On-LAN – Customized Packet, Type 0, Expected CRC 0				
MMD Address 1Fh, Register Bh – Wake-On-LAN – Customized Packet, Type 1, Expected CRC 0				
MMD Address 1Fh, Register 11h – Wake-On-LAN – Customized Packet, Type 2, Expected CRC 0				
MMD Address 1Fh, Register 17h – Wake-On-LAN – Customized Packet, Type 3, Expected CRC 0				
1F.5.15:0 1F.B.15:0 1F.11.15:0 1F.17.15:0	Custom Packet Type X CRC 0	<p>This register stores the lower two bytes for the expected CRC.</p> <p>Bit [15:8]= Byte 2 (CRC [15:8]) Bit [7:0] = Byte 1 (CRC [7:0])</p> <p>The upper two bytes for the expected CRC are stored in the following register.</p>	RW	0000_0000_0000_0000

MMD Registers – Descriptions (Continued)

Address	Name	Description	Mode ⁽⁸⁾	Default
MMD Address 1Fh, Register 6h – Wake-On-LAN – Customized Packet, Type 0, Expected CRC 1				
MMD Address 1Fh, Register Ch – Wake-On-LAN – Customized Packet, Type 1, Expected CRC 1				
MMD Address 1Fh, Register 12h – Wake-On-LAN – Customized Packet, Type 2, Expected CRC 1				
MMD Address 1Fh, Register 18h – Wake-On-LAN – Customized Packet, Type 3, Expected CRC 1				
1F.6.15:0 1F.C.15:0 1F.12.15:0 1F.18.15:0	Custom Packet Type X CRC 1	This register stores the upper two bytes for the expected CRC. Bit [15:8]= Byte 4 (CRC [31:24]) Bit [7:0] = Byte 3 (CRC [23:16]) The lower two bytes for the expected CRC are stored in the previous register.	RW	0000_0000_0000_0000
MMD Address 1Fh, Register 19h – Wake-On-LAN – Magic Packet, MAC-DA-0				
1F.19.15:0	Magic Packet MAC-DA-0	This register stores the lower two bytes of the destination MAC address for the magic packet. Bit [15:8]= Byte 2 (MAC Address [15:8]) Bit [7:0] = Byte 1 (MAC Address [7:0]) The upper four bytes of the destination MAC address are stored in the following two registers.	RW	0000_0000_0000_0000
MMD Address 1Fh, Register 1Ah – Wake-On-LAN – Magic Packet, MAC-DA-1				
1F.1A.15:0	Magic Packet MAC-DA-1	This register stores the middle two bytes of the destination MAC address for the magic packet. Bit [15:8]= Byte 4 (MAC Address [31:24]) Bit [7:0] = Byte 3 (MAC Address [23:16]) The lower two bytes and upper two bytes of the destination MAC address are stored in the previous and following registers, respectively.	RW	0000_0000_0000_0000
MMD Address 1Fh, Register 1Bh – Wake-On-LAN – Magic Packet, MAC-DA-2				
1F.1B.15:0	Magic Packet MAC-DA-2	This register stores the upper two bytes of the destination MAC address for the magic packet. Bit [15:8]= Byte 6 (MAC Address [47:40]) Bit [7:0] = Byte 5 (MAC Address [39:32]) The lower four bytes of the destination MAC address are stored in the previous two registers.	RW	0000_0000_0000_0000

Absolute Maximum Ratings⁽⁹⁾

Supply Voltage (V_{IN})	
($V_{DD_1.2}$)	-0.5V to +1.8V
($V_{DDIO}, V_{DDA_3.3}$)	-0.5V to +5.0V
Input Voltage (all inputs)	-0.5V to +5.0V
Output Voltage (all outputs)	-0.5V to +5.0V
Lead Temperature (soldering, 10s)	260°C
Storage Temperature (T_S)	-55°C to +150°C

Operating Ratings⁽¹⁰⁾

Supply Voltage	
($V_{DDIO_3.3}, V_{DDA_3.3}$)	+3.135V to +3.465V
($V_{DDIO_2.5}$)	+2.375V to +2.625V
($V_{DDIO_1.8}$)	+1.710V to +1.890V
Ambient Temperature	
(T_A , Commercial)	0°C to +70°C
(T_A , Industrial)	-40°C to +85°C
Maximum Junction Temperature (T_J max.)	125°C
Thermal Resistance (θ_{JA})	49.22°C/W
Thermal Resistance (θ_{JC})	25.65°C/W

Electrical Characteristics⁽¹¹⁾

Symbol	Parameter	Condition	Min.	Typ.	Max.	Units
Supply Current ($V_{DDIO}, V_{DDA_3.3} = 3.3V$)⁽¹²⁾						
$I_{DD1_3.3V}$	10Base-T	Full-duplex traffic @ 100% utilization		41		mA
$I_{DD2_3.3V}$	100Base-TX	Full-duplex traffic @ 100% utilization		47		mA
$I_{DD3_3.3V}$	EEE (100Mbps) Mode	TX and RX paths in LPI state with no traffic		23		mA
$I_{DD4_3.3V}$	EDPD Mode	Ethernet cable disconnected (Reg. 18h.11 = 0)		20		mA
$I_{DD5_3.3V}$	Power-Down Mode	Software power-down (Reg. 0h.11 = 1)		4		mA
CMOS Level Inputs						
V_{IH}	Input High Voltage	$V_{DDIO} = 3.3V$	2.0			V
		$V_{DDIO} = 2.5V$	1.8			
		$V_{DDIO} = 1.8V$	1.3			
V_{IL}	Input Low Voltage	$V_{DDIO} = 3.3V$			0.8	V
		$V_{DDIO} = 2.5V$			0.7	
		$V_{DDIO} = 1.8V$			0.5	
$ I_{IN} $	Input Current	$V_{IN} = GND \sim V_{DDIO}$			10	μA
CMOS Level Outputs						
V_{OH}	Output High Voltage	$V_{DDIO} = 3.3V$	2.4			V
		$V_{DDIO} = 2.5V$	2.0			
		$V_{DDIO} = 1.8V$	1.5			
V_{OL}	Output Low Voltage	$V_{DDIO} = 3.3V$			0.4	V
		$V_{DDIO} = 2.5V$			0.4	
		$V_{DDIO} = 1.8V$			0.3	
$ I_{OZ} $	Output Tri-State Leakage				10	μA
LED Output						
I_{LED}	Output Drive Current	LED0 pin		8		mA

Notes:

9. Exceeding the absolute maximum ratings may damage the device. Stresses greater than the absolute maximum rating can cause permanent damage to the device. Operation of the device at these or any other conditions above those specified in the operating sections of this specification is not implied. Maximum conditions for extended periods may affect reliability.
10. The device is not guaranteed to function outside its operating ratings.
11. $T_A = 25^\circ C$. Specification for packaged product only.
12. Current consumption is for the single 3.3V supply KSZ8091RNA/RND device only, and includes the transmit driver current and the 1.2V supply voltage ($V_{DD_1.2}$) that are supplied by the KSZ8091RNA/RND

Electrical Characteristics⁽¹¹⁾ (Continued)

Symbol	Parameter	Condition	Min.	Typ.	Max.	Units
All Pull-Up/Pull-Down Pins (including Strapping Pins)						
pu	Internal Pull-Up Resistance	V _{DDIO} = 3.3V	30	45	73	kΩ
		V _{DDIO} = 2.5V	39	61	102	
		V _{DDIO} = 1.8V	48	99	178	
pd	Internal Pull-Down Resistance	V _{DDIO} = 3.3V	26	43	79	kΩ
		V _{DDIO} = 2.5V	34	59	113	
		V _{DDIO} = 1.8V	53	99	200	
100Base-TX Transmit (measured differentially after 1:1 transformer)						
V _O	Peak Differential Output Voltage	100Ω termination across differential output	0.95		1.05	V
V _{IMB}	Output Voltage Imbalance	100Ω termination across differential output			2	%
t _r , t _f	Rise/Fall Time		3		5	ns
	Rise/Fall Time Imbalance		0		0.5	ns
	Duty Cycle Distortion				±0.25	ns
	Overshoot				5	%
	Output Jitter	Peak-to-peak		0.7		ns
10Base-T Transmit (measured differentially after 1:1 transformer)						
V _P	Peak Differential Output Voltage	100Ω termination across differential output	2.2		2.8	V
	Jitter Added	Peak-to-peak			3.5	ns
t _r , t _f	Rise/Fall Time			25		ns
10Base-T Receive						
V _{SQ}	Squelch Threshold	5MHz square wave		400		mV
Transmitter – Drive Setting						
V _{SET}	Reference Voltage of I _{SET}	R(I _{SET}) = 6.49kΩ		0.65		V
REF_CLK Output						
	50MHz RMI Clock Output Jitter	Peak-to-peak (Applies only to RMI – 25MHz clock mode)		300		ps
100Mbps Mode – Industrial Applications Parameters						
t _{llr}	Link Loss Reaction (Indication) Time	Link loss detected at receive differential inputs to PHY signal indication time for each of the following: 1. For LED mode 01, Link LED output changes from low (link-up) to high (link-down). 2. INTRP pin asserts for link-down status change.		4.4		μs

Timing Diagrams

RMII Timing

TRANSMIT TIMING

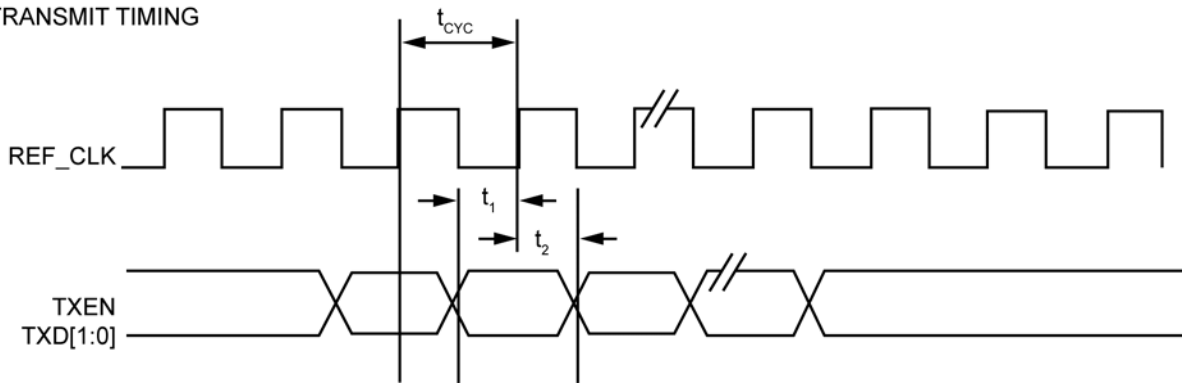

Figure 13. RMII Timing – Data Received from RMII

RECEIVE TIMING

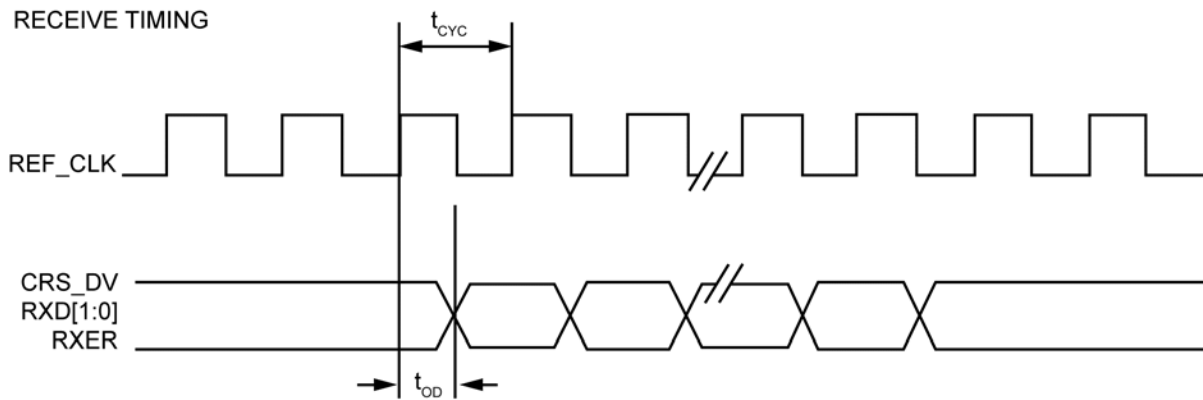

Figure 14. RMII Timing – Data Input to RMII

Table 13. RMII Timing Parameters – KSZ8091RNA/RND (25MHz input to XI pin, 50MHz output from REF_CLK pin)

Timing Parameter	Description	Min.	Typ.	Max.	Unit
t_{cyc}	Clock cycle		20		ns
t_1	Setup time	4			ns
t_2	Hold time	2			ns
t_{OD}	Output delay	7	10	13	ns

Table 14. RMII Timing Parameters – KSZ8091RNA/RND (50MHz input to XI pin)

Timing Parameter	Description	Min.	Typ.	Max.	Unit
t_{cyc}	Clock cycle		20		ns
t_1	Setup time	4			ns
t_2	Hold time	2			ns
t_{OD}	Output delay	8	11	13	ns

Auto-Negotiation Timing

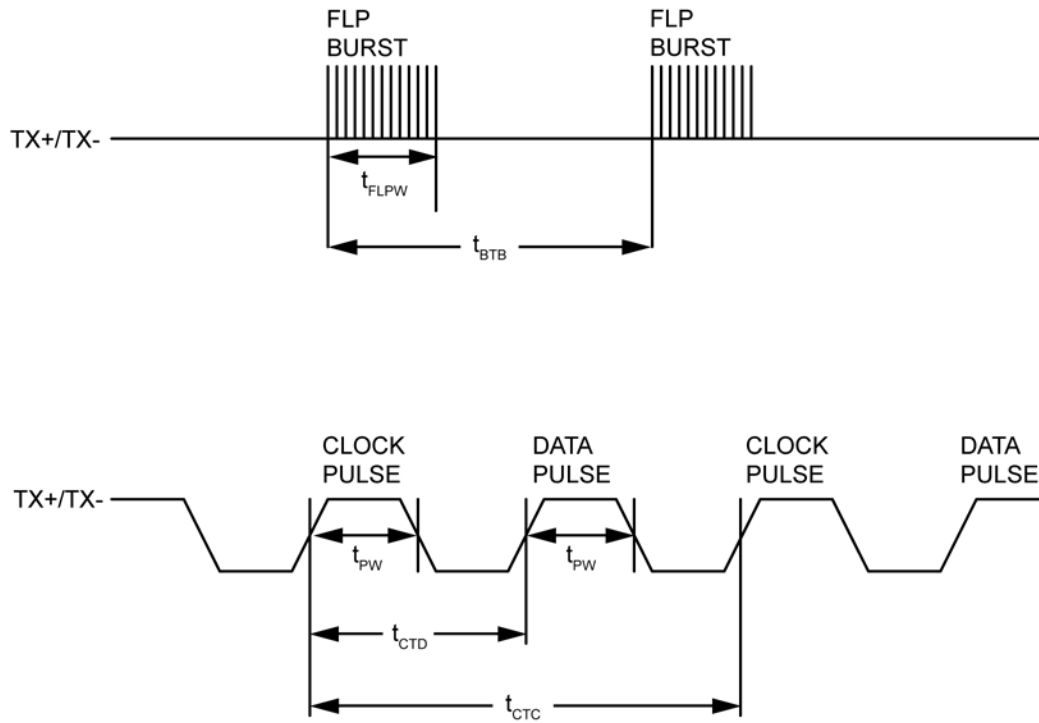

Figure 15. Auto-Negotiation Fast Link Pulse (FLP) Timing

Table 15. Auto-Negotiation Fast Link Pulse (FLP) Timing Parameters

Timing Parameter	Description	Min.	Typ.	Max.	Unit
t_{BTB}	FLP burst to FLP burst	8	16	24	ms
t_{FLPW}	FLP burst width		2		ms
t_{PW}	Clock/Data pulse width		100		ns
t_{CTD}	Clock pulse to data pulse	55.5	64	69.5	μ s
t_{CTC}	Clock pulse to clock pulse	111	128	139	μ s
	Number of clock/data pulses per FLP burst	17		33	

MDC/MDIO Timing

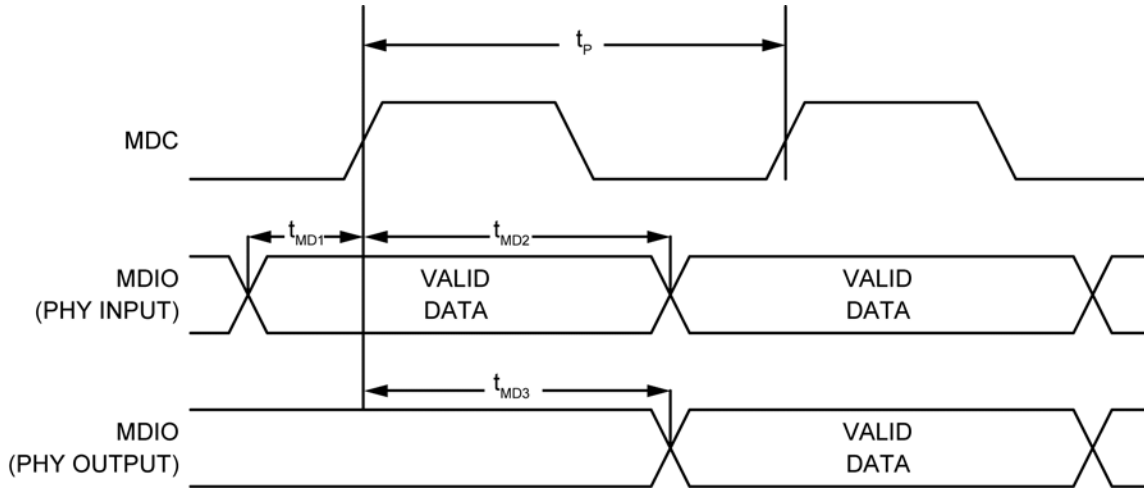

Figure 16. MDC/MDIO Timing

Table 16. MDC/MDIO Timing Parameters

Timing Parameter	Description	Min.	Typ.	Max.	Unit
f_c	MDC Clock Frequency		2.5	10	MHz
t_p	MDC period		400		ns
t_{MD1}	MDIO (PHY input) setup to rising edge of MDC	10			ns
t_{MD2}	MDIO (PHY input) hold from rising edge of MDC	4			ns
t_{MD3}	MDIO (PHY output) delay from rising edge of MDC	5	222		ns

Power-Up/Reset Timing

The KSZ8091RNA/RND reset timing requirement is summarized in Figure 17 and Table 17.

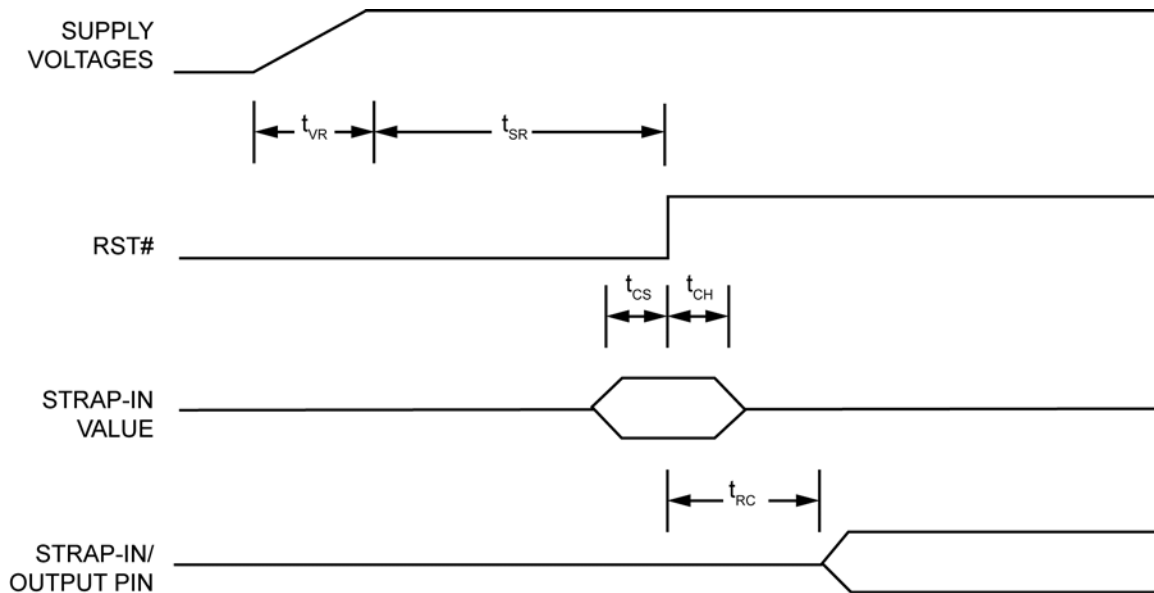

Figure 17. Power-Up/Reset Timing

Table 17. Power-Up/Reset Timing Parameters

Timing Parameter	Description	Min.	Typ.	Max.	Unit
t_{VR}	Supply voltage (V_{DDIO} , $V_{DDA_{3.3}}$) rise time	300			μs
t_{SR}	Stable supply voltage (V_{DDIO} , $V_{DDA_{3.3}}$) to reset high	10			ms
t_{CS}	Configuration setup time	5			ns
t_{CH}	Configuration hold time	5			ns
t_{RC}	Reset to strap-in pin output	6			ns

The supply voltage (V_{DDIO} and $V_{DDA_{3.3}}$) power-up waveform should be monotonic. The 300 μs minimum rise time is from 10% to 90%.

For warm reset, the reset (RST#) pin should be asserted low for a minimum of 500 μs . The strap-in pin values are read and updated at the de-assertion of reset.

After the de-assertion of reset, wait a minimum of 100 μs before starting programming on the MIIM (MDC/MDIO) interface.

Reset Circuit

Figure 18 shows a reset circuit recommended for powering up the KSZ8091RNA/RND if reset is triggered by the power supply.

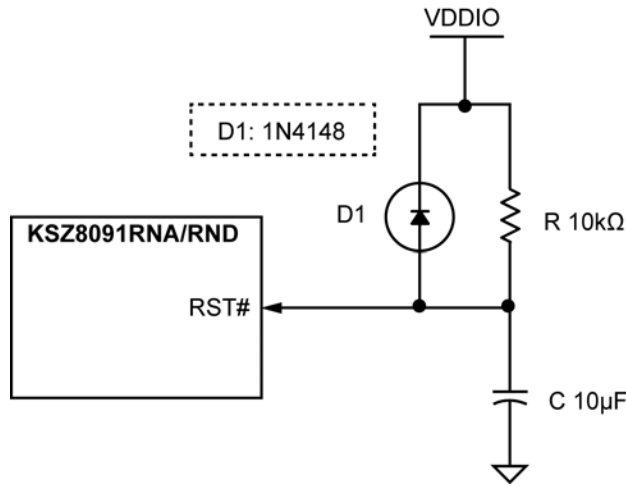

Figure 18. Recommended Reset Circuit

Figure 19 Shows a reset circuit recommended for applications where reset is driven by another device (for example, the CPU or an FPGA). The reset out RST_OUT_n from CPU/FPGA provides the warm reset after power up reset. D2 is used if using different VDDIO between the switch and CPU/FPGA, otherwise, the different VDDIO will fight each other. If different VDDIO have to use in a special case, a low VF (<0.3V) diode is required (For example, VISHAY’s BAT54, MSS1P2L and so on), or a level shifter device can be used too. If Ethernet device and CPU/FPGA use same VDDIO voltage, D2 can be removed to connect both devices directly. Usually, Ethernet device and CPU/FPGA should use same VDDIO voltage.

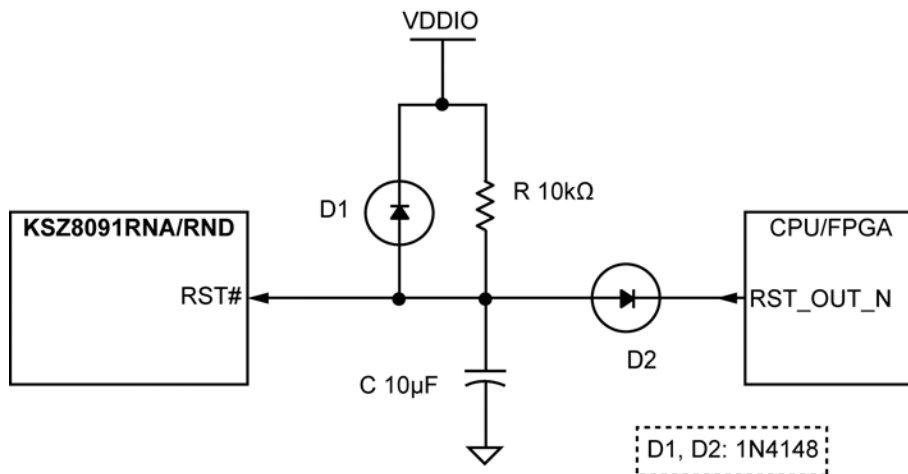

Figure 19. Recommended Reset Circuit for Interfacing with CPU/FPGA Reset Output

Reference Circuits – LED Strap-In Pin

The pull-up, float, and pull-down reference circuits for the LED0/ANEN_SPEED strapping pin are shown in Figure 20 for 3.3V and 2.5V VDDIO.

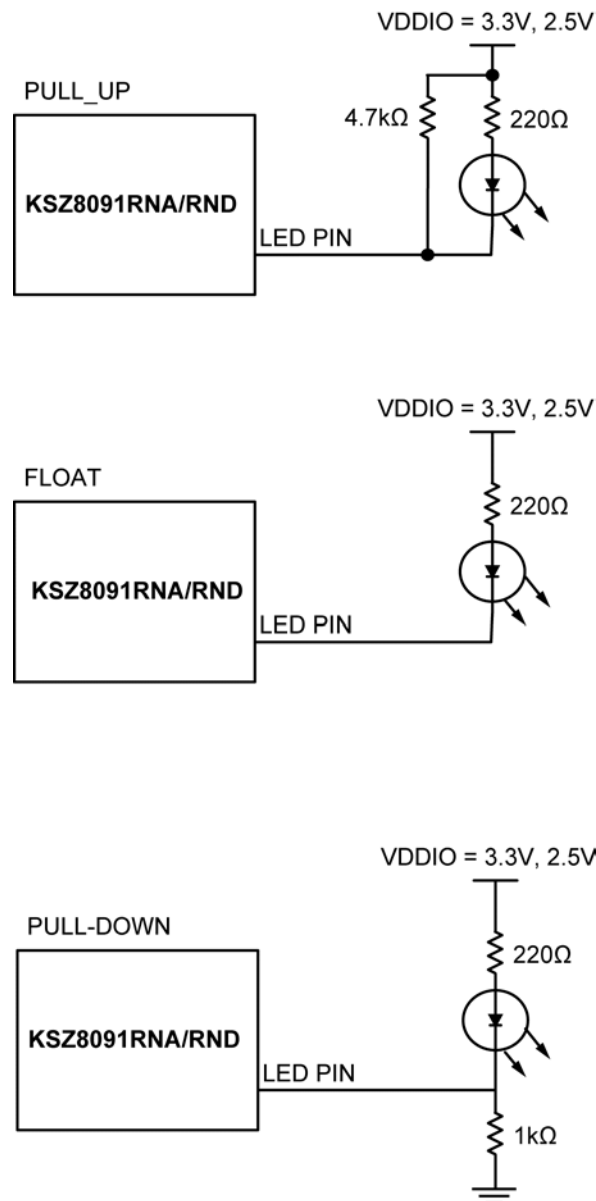

Figure 20. Reference Circuits for LED Strapping Pin

For 1.8V VDDIO, LED indication support is not recommended due to the low voltage. Without the LED indicator, the ANEN_SPEED strapping pin is functional with a 4.7kΩ pull-up to 1.8V VDDIO or float for a value of '1', and with a 1.0kΩ pull-down to ground for a value of '0'.

Note: If using RJ45 jacks with integrated LEDs and 1.8V VDDIO, a level shifting is required from LED 3.3V to 1.8V. For example, use a bipolar transistor or a level shift device.

Reference Clock – Connection and Selection

A crystal or external clock source, such as an oscillator, is used to provide the reference clock for the KSZ8091RNA/RND.

For the KSZ8091RNA/RND in RMII – 25MHz clock mode, the reference clock is 25MHz. The crystal/reference clock connections to XI (Pin 8) and XO (Pin 7), and the crystal / reference clock selection criteria, are provided in [Figure 21](#) and [Table 18](#).

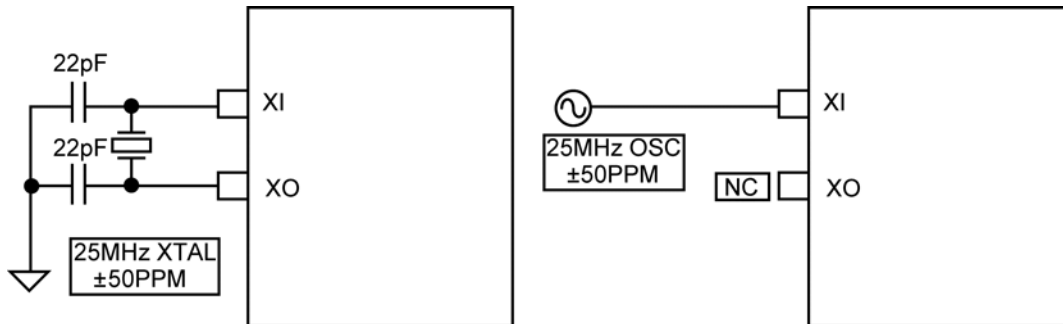

Figure 21. 25MHz Crystal/Oscillator Reference Clock Connection

Table 18. 25MHz Crystal/Reference Clock Selection Criteria

Characteristics	Value	Units
Frequency	25	MHz
Frequency tolerance (max.)()	±50	ppm
Crystal series resistance (typ.)	40	Ω
Crystal load capacitance (typ.)	22	pF

Note:

13. ±60ppm for overtemperature crystal.

For the KSZ8091RNA/RND in RMII – 50MHz clock mode, the reference clock is 50MHz. The reference clock connection to XI (Pin 8) and the reference clock selection criteria are provided in [Figure 22](#) and [Table 19](#).

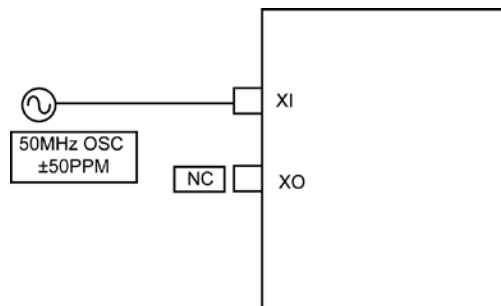

Figure 22. 50MHz Oscillator/Reference Clock Connection

Table 19. 50MHz Oscillator/Reference Clock Selection Criteria

Characteristics	Value	Units
Frequency	50	MHz
Frequency tolerance (max.)	±50	ppm

Magnetic – Connection and Selection

A 1:1 isolation transformer is required at the line interface. Use one with integrated common-mode chokes for designs exceeding FCC requirements.

The KSZ8091RNA/RND design incorporates voltage-mode transmit drivers and on-chip terminations.

With the voltage-mode implementation, the transmit drivers supply the common-mode voltages to the two differential pairs. Therefore, the two transformer center tap pins on the KSZ8091RNA/RND side should not be connected to any power supply source on the board; instead, the center tap pins should be separated from one another and connected through separate 0.1μF common-mode capacitors to ground. Separation is required because the common-mode voltage is different between transmitting and receiving differential pairs.

Figure 23 shows the typical magnetic interface circuit for the KSZ8091RNA/RND.

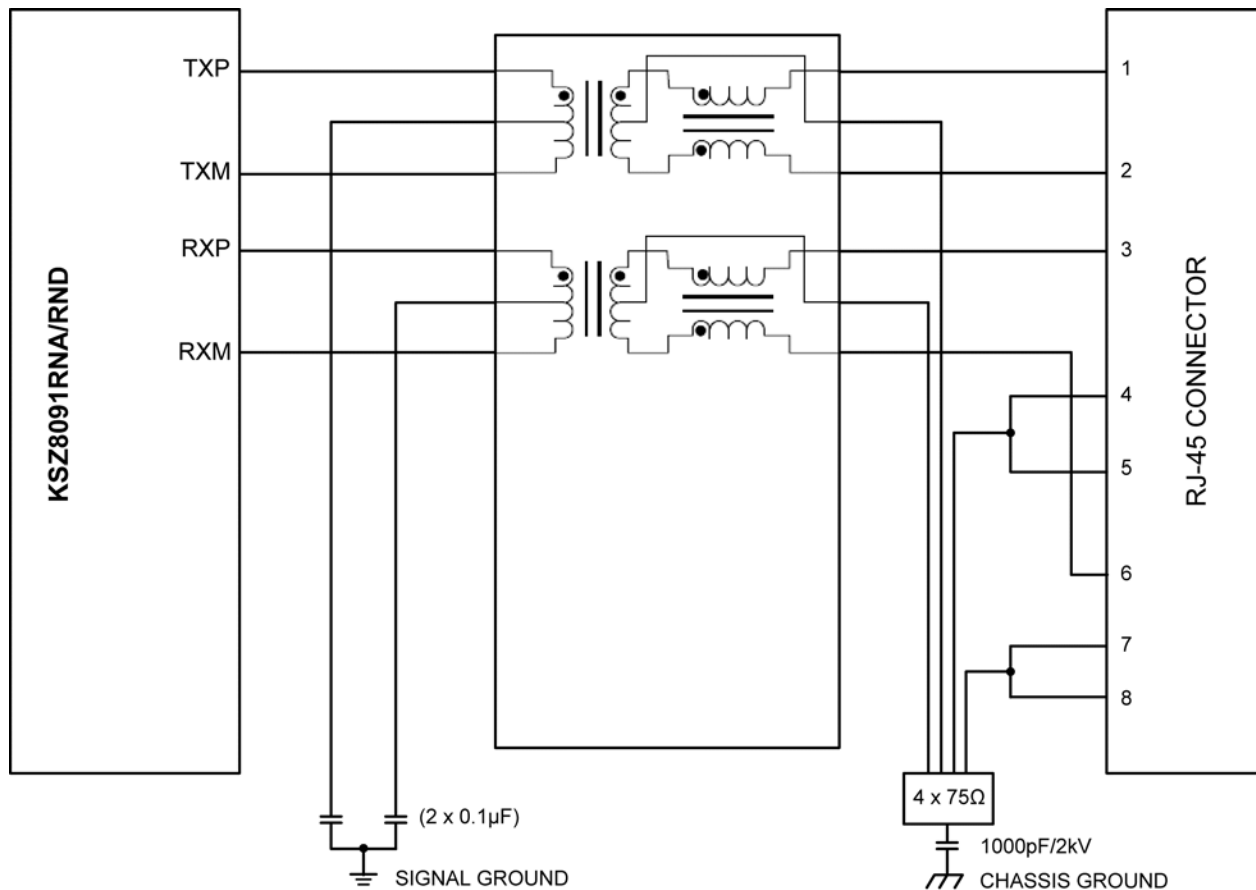

Figure 23. Typical Magnetic Interface Circuit

Table 20 lists recommended magnetic characteristics.

Table 20. Magnetics Selection Criteria

Parameter	Value	Test Condition
Turns ratio	1 CT : 1 CT	
Open-circuit inductance (min.)	350 μ H	100mV, 100kHz, 8mA
Insertion loss (typ.)	-1.1dB	100kHz to 100MHz
HIPOT (min.)	1500Vrms	

Table 21 is a list of compatible single-port magnetics with separated transformer center tap pins on the PHY chip side that can be used with the KSZ8091RNA/RND.

Table 21. Compatible Single-Port 10/100 Magnetics

Manufacturer	Part Number	Temperature Range	Magnetic + RJ-45
Bel Fuse	S558-5999-U7	0°C to 70°C	No
Bel Fuse	SI-46001-F	0°C to 70°C	Yes
Bel Fuse	SI-50170-F	0°C to 70°C	Yes
Delta	LF8505	0°C to 70°C	No
HALO	HFJ11-2450E	0°C to 70°C	Yes
HALO	TG110-E055N5	-40°C to 85°C	No
LANKom	LF-H41S-1	0°C to 70°C	No
Pulse	H1102	0°C to 70°C	No
Pulse	H1260	0°C to 70°C	No
Pulse	HX1188	-40°C to 85°C	No
Pulse	J00-0014	0°C to 70°C	Yes
Pulse	JX0011D21NL	-40°C to 85°C	Yes
TDK	TLA-6T718A	0°C to 70°C	Yes
Transpower	HB726	0°C to 70°C	No
Würth/Midcom	000-7090-37R-LF1	-40°C to 85°C	No

Package Information and Recommended Land Pattern⁽¹⁴⁾

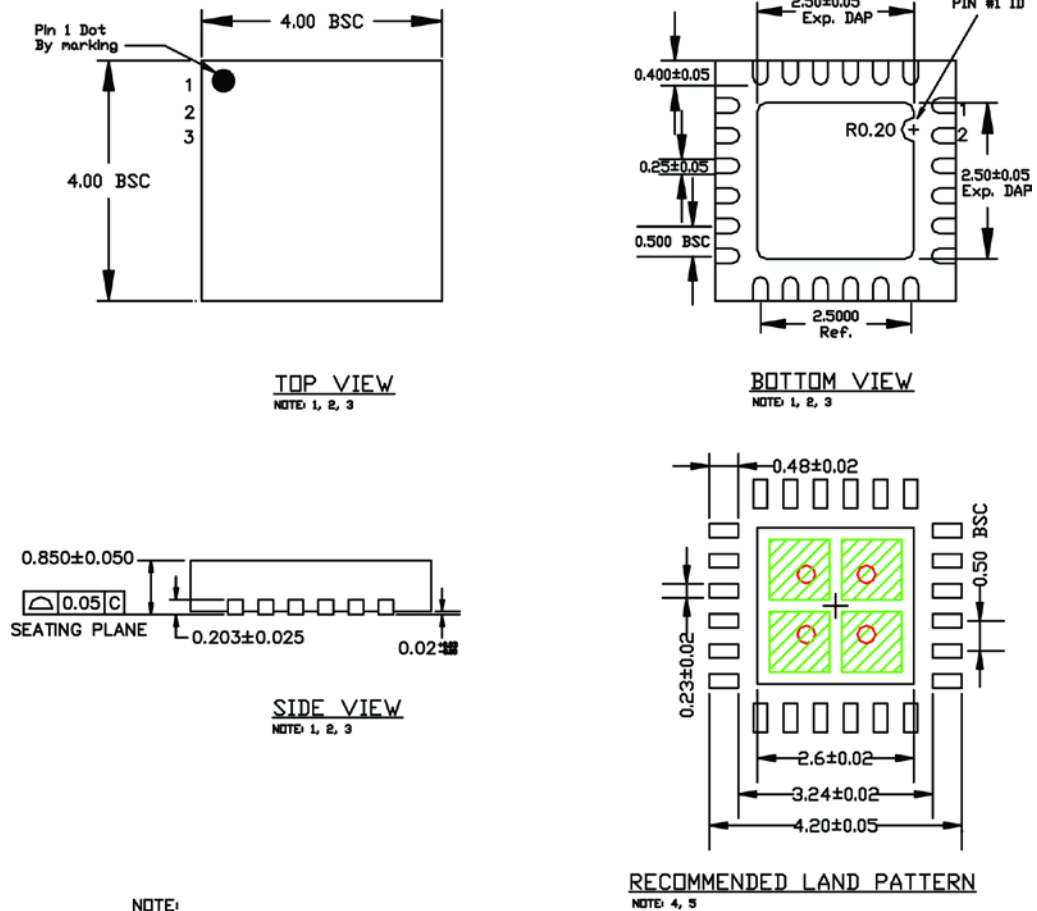

- NOTE:
1. MAX PACKAGE WARPAGE IS 0.05 MM
 2. MAX ALLOWABLE BURR IS 0.076MM IN ALL DIRECTIONS
 3. PIN #1 IS ON TOP WILL BE LASER MARKED
 4. RED CIRCLE IN LAND PATTERN INDICATE THERMAL VIA. SIZE SHOULD BE 0.30-0.35M IN DIAMETER AND SHOULD BE CONNECTED TO GND FOR MAX THERMAL PERFORMANCE
 5. GREEN RECTANGLES (SHADED AREA) INDICATE SOLDER STENCIL OPENING ON EXPOSED PAD AREA. SIZE SHOULD BE 1.00x1.00 MM IN SIZE, 1.20 MM PITCH.

24-Pin (4mm x 4mm) QFN

Note:

14. Package information is correct as of the publication date. For updates and most current information, go to www.micrel.com.

MICREL, INC. 2180 FORTUNE DRIVE SAN JOSE, CA 95131 USATEL +1 (408) 944-0800 FAX +1 (408) 474-1000 WEB <http://www.micrel.com>

Micrel, Inc. is a leading global manufacturer of IC solutions for the worldwide high performance linear and power, LAN, and timing & communications markets. The Company's products include advanced mixed-signal, analog & power semiconductors; high-performance communication, clock management, MEMs-based clock oscillators & crystal-less clock generators, Ethernet switches, and physical layer transceiver ICs. Company customers include leading manufacturers of enterprise, consumer, industrial, mobile, telecommunications, automotive, and computer products. Corporation headquarters and state-of-the-art wafer fabrication facilities are located in San Jose, CA, with regional sales and support offices and advanced technology design centers situated throughout the Americas, Europe, and Asia. Additionally, the Company maintains an extensive network of distributors and reps worldwide.

Micrel makes no representations or warranties with respect to the accuracy or completeness of the information furnished in this datasheet. This information is not intended as a warranty and Micrel does not assume responsibility for its use. Micrel reserves the right to change circuitry, specifications and descriptions at any time without notice. No license, whether express, implied, arising by estoppel or otherwise, to any intellectual property rights is granted by this document. Except as provided in Micrel's terms and conditions of sale for such products, Micrel assumes no liability whatsoever, and Micrel disclaims any express or implied warranty relating to the sale and/or use of Micrel products including liability or warranties relating to fitness for a particular purpose, merchantability, or infringement of any patent, copyright, or other intellectual property right.

Micrel Products are not designed or authorized for use as components in life support appliances, devices or systems where malfunction of a product can reasonably be expected to result in personal injury. Life support devices or systems are devices or systems that (a) are intended for surgical implant into the body or (b) support or sustain life, and whose failure to perform can be reasonably expected to result in a significant injury to the user. A Purchaser's use or sale of Micrel Products for use in life support appliances, devices or systems is a Purchaser's own risk and Purchaser agrees to fully indemnify Micrel for any damages resulting from such use or sale.

© 2013 Micrel, Incorporated.



Стандарт Электрон Связь

Мы молодая и активно развивающаяся компания в области поставок электронных компонентов. Мы поставляем электронные компоненты отечественного и импортного производства напрямую от производителей и с крупнейших складов мира.

Благодаря сотрудничеству с мировыми поставщиками мы осуществляем комплексные и плановые поставки широчайшего спектра электронных компонентов.

Собственная эффективная логистика и склад в обеспечивает надежную поставку продукции в точно указанные сроки по всей России.

Мы осуществляем техническую поддержку нашим клиентам и предпродажную проверку качества продукции. На все поставляемые продукты мы предоставляем гарантию .

Осуществляем поставки продукции под контролем ВП МО РФ на предприятия военно-промышленного комплекса России , а также работаем в рамках 275 ФЗ с открытием отдельных счетов в уполномоченном банке. Система менеджмента качества компании соответствует требованиям ГОСТ ISO 9001.

Минимальные сроки поставки, гибкие цены, неограниченный ассортимент и индивидуальный подход к клиентам являются основой для выстраивания долгосрочного и эффективного сотрудничества с предприятиями радиоэлектронной промышленности, предприятиями ВПК и научно-исследовательскими институтами России.

С нами вы становитесь еще успешнее!

Наши контакты:

Телефон: +7 812 627 14 35

Электронная почта: sales@st-electron.ru

Адрес: 198099, Санкт-Петербург,
Промышленная ул, дом № 19, литера Н,
помещение 100-Н Офис 331