



MICROCHIP

**EVB-LAN9355
Evaluation Board
User's Guide**

Note the following details of the code protection feature on Microchip devices:

- Microchip products meet the specification contained in their particular Microchip Data Sheet.
- Microchip believes that its family of products is one of the most secure families of its kind on the market today, when used in the intended manner and under normal conditions.
- There are dishonest and possibly illegal methods used to breach the code protection feature. All of these methods, to our knowledge, require using the Microchip products in a manner outside the operating specifications contained in Microchip's Data Sheets. Most likely, the person doing so is engaged in theft of intellectual property.
- Microchip is willing to work with the customer who is concerned about the integrity of their code.
- Neither Microchip nor any other semiconductor manufacturer can guarantee the security of their code. Code protection does not mean that we are guaranteeing the product as "unbreakable."

Code protection is constantly evolving. We at Microchip are committed to continuously improving the code protection features of our products. Attempts to break Microchip's code protection feature may be a violation of the Digital Millennium Copyright Act. If such acts allow unauthorized access to your software or other copyrighted work, you may have a right to sue for relief under that Act.

Information contained in this publication regarding device applications and the like is provided only for your convenience and may be superseded by updates. It is your responsibility to ensure that your application meets with your specifications. MICROCHIP MAKES NO REPRESENTATIONS OR WARRANTIES OF ANY KIND WHETHER EXPRESS OR IMPLIED, WRITTEN OR ORAL, STATUTORY OR OTHERWISE, RELATED TO THE INFORMATION, INCLUDING BUT NOT LIMITED TO ITS CONDITION, QUALITY, PERFORMANCE, MERCHANTABILITY OR FITNESS FOR PURPOSE. Microchip disclaims all liability arising from this information and its use. Use of Microchip devices in life support and/or safety applications is entirely at the buyer's risk, and the buyer agrees to defend, indemnify and hold harmless Microchip from any and all damages, claims, suits, or expenses resulting from such use. No licenses are conveyed, implicitly or otherwise, under any Microchip intellectual property rights unless otherwise stated.

Trademarks

The Microchip name and logo, the Microchip logo, dsPIC, FlashFlex, flexPWR, JukeBlox, KEELOQ, KEELOQ logo, Kleer, LANCheck, MediaLB, MOST, MOST logo, MPLAB, OptoLyzer, PIC, PICSTART, PIC³² logo, RightTouch, SpyNIC, SST, SST Logo, SuperFlash and UNI/O are registered trademarks of Microchip Technology Incorporated in the U.S.A. and other countries.

The Embedded Control Solutions Company and mTouch are registered trademarks of Microchip Technology Incorporated in the U.S.A.

Analog-for-the-Digital Age, BodyCom, chipKIT, chipKIT logo, CodeGuard, dsPICDEM, dsPICDEM.net, ECAN, In-Circuit Serial Programming, ICSP, Inter-Chip Connectivity, KleerNet, KleerNet logo, MiWi, MPASM, MPF, MPLAB Certified logo, MPLIB, MPLINK, MultiTRAK, NetDetach, Omniscient Code Generation, PICDEM, PICDEM.net, PICKit, PICTail, RightTouch logo, REAL ICE, SQI, Serial Quad I/O, Total Endurance, TSHARC, USBCheck, VariSense, ViewSpan, WiperLock, Wireless DNA, and ZENA are trademarks of Microchip Technology Incorporated in the U.S.A. and other countries.

SQTP is a service mark of Microchip Technology Incorporated in the U.S.A.

Silicon Storage Technology is a registered trademark of Microchip Technology Inc. in other countries.

GestIC is a registered trademark of Microchip Technology Germany II GmbH & Co. KG, a subsidiary of Microchip Technology Inc., in other countries.

All other trademarks mentioned herein are property of their respective companies.

© 2015, Microchip Technology Incorporated, Printed in the U.S.A., All Rights Reserved.

ISBN: 978-1-63277-589-4

**QUALITY MANAGEMENT SYSTEM
CERTIFIED BY DNV
= ISO/TS 16949 =**

Microchip received ISO/TS-16949:2009 certification for its worldwide headquarters, design and wafer fabrication facilities in Chandler and Tempe, Arizona; Gresham, Oregon and design centers in California and India. The Company's quality system processes and procedures are for its PIC[®] MCUs and dsPIC[®] DSCs, KEELOQ[®] code hopping devices, Serial EEPROMs, microperipherals, nonvolatile memory and analog products. In addition, Microchip's quality system for the design and manufacture of development systems is ISO 9001:2000 certified.

Object of Declaration: EVB-LAN9355

EU Declaration of Conformity

This declaration of conformity is issued by the manufacturer.

The development/evaluation tool is designed to be used for research and development in a laboratory environment. This development/evaluation tool is not a Finished Appliance, nor is it intended for incorporation into Finished Appliances that are made commercially available as single functional units to end users under EU EMC Directive 2004/108/EC and as supported by the European Commission's Guide for the EMC Directive 2004/108/EC (8th February 2010).

This development/evaluation tool complies with EU RoHS2 Directive 2011/65/EU.

For information regarding the exclusive, limited warranties applicable to Microchip products, please see Microchip's standard terms and conditions of sale, which are printed on our sales documentation and available at www.microchip.com.

Signed for and on behalf of Microchip Technology Inc. at Chandler, Arizona, USA

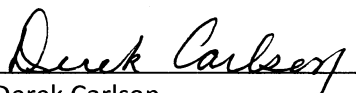

Derek Carlson
VP Development Tools



Date

NOTES:

Table of Contents

Preface	7
Introduction.....	7
Document Layout	7
Conventions Used in this Guide	8
The Microchip Web Site	9
Development Systems Customer Change Notification Service	9
Customer Support	9
Document Revision History	10
 Chapter 1. Overview	
1.1 Introduction	11
1.1.1 References	12
1.1.2 Terms and Abbreviations	12
 Chapter 2. Board Details	
2.1 Board Details	14
2.1.1 Power	14
2.1.2 Power-on Reset	14
2.1.3 Clock	15
 Chapter 3. Board Configuration	
3.1 Strap Options	16
3.1.1 Jumpers J4:J15	16
3.1.1.1 GPIO/LED POL/LED Configurations	17
3.1.1.2 Serial Management Mode Configuration	18
3.1.1.3 EEPROM Size Configuration	18
3.1.1.4 Energy-Efficient Ethernet Configuration	18
3.1.1.5 1588 Enable Configuration	19
3.1.1.6 PHY Address Configuration	19
3.1.2 GPIO 6 & GPIO 7 Input and Output Configurations	19
3.1.3 Link Partner Duplex/Speed Configurations	20
3.1.4 P0/P1 Configurations	21
3.1.5 RMIi RX Clock Configurations	22
3.1.6 GPIO Header	22
3.1.7 I2C Aardvark Header	22
3.1.8 Copper and Fiber Mode Selections	23
3.1.8.1 Copper Mode	23
3.1.8.2 Fiber Mode	23
3.1.8.3 FX-LOS Fiber Mode Strap	24
3.2 LEDs	24
3.3 Test Points	24
3.4 Mechanicals	25

Appendix A. EVB-LAN9355 Evaluation Board

A.1 Introduction 26

Appendix B. EVB-LAN9355 Evaluation Board Schematics

B.1 Introduction 27

Appendix C. Bill of Materials (BOM)

C.1 Introduction 36

Wordwide Sales and Service 40

Preface

NOTICE TO CUSTOMERS

All documentation becomes dated, and this manual is no exception. Microchip tools and documentation are constantly evolving to meet customer needs, so some actual dialogs and/or tool descriptions may differ from those in this document. Please refer to our web site (www.microchip.com) to obtain the latest documentation available.

Documents are identified with a “DS” number. This number is located on the bottom of each page, in front of the page number. The numbering convention for the DS number is “DSXXXXA”, where “XXXX” is the document number and “A” is the revision level of the document.

For the most up-to-date information on development tools, see the MPLAB® IDE online help. Select the Help menu, and then Topics to open a list of available online help files.

INTRODUCTION

This chapter contains general information that will be useful to know before using the EVB-LAN9355. Items discussed in this chapter include:

- [Document Layout](#)
- [Conventions Used in this Guide](#)
- [The Microchip Web Site](#)
- [Development Systems Customer Change Notification Service](#)
- [Customer Support](#)
- [Document Revision History](#)

DOCUMENT LAYOUT

This document describes how to use the EVB-LAN9355 Evaluation Board as a development tool for the LAN9355 three-port 10/100 managed Ethernet switch. The manual layout is as follows:

- **Chapter 1. “Overview”** – Shows a brief description of the EVB-LAN9355 Evaluation Board.
- **Chapter 2. “Getting Started”** – Includes instructions on how to get started with the EVB-LAN9355 Evaluation Board.
- **Chapter 3. “Board Configuration”** – Provides information about the EVB-LAN9355 Evaluation Board battery charging features.
- **Appendix A. “EVB-LAN9355 Evaluation Board”** – This appendix shows the EVB-LAN9355 Evaluation Board.
- **Appendix B. “EVB-LAN9355 Evaluation Board Schematics”** – This appendix shows the EVB-LAN9355 Evaluation Board schematics.
- **Appendix C. “Bill of Materials (BOM)”** – This appendix includes the EVB-LAN9355 Evaluation Board Bill of Materials (BOM).

CONVENTIONS USED IN THIS GUIDE

This manual uses the following documentation conventions:

DOCUMENTATION CONVENTIONS

Description	Represents	Examples
Arial font:		
Italic characters	Referenced books	<i>MPLAB® IDE User's Guide</i>
	Emphasized text	...is the <i>only</i> compiler...
Initial caps	A window	the Output window
	A dialog	the Settings dialog
	A menu selection	select Enable Programmer
Quotes	A field name in a window or dialog	"Save project before build"
Underlined, italic text with right angle bracket	A menu path	<u>File</u> > <i>Save</i>
Bold characters	A dialog button	Click OK
	A tab	Click the Power tab
N'Rnnnn	A number in verilog format, where N is the total number of digits, R is the radix and n is a digit.	4'b0010, 2'hF1
Text in angle brackets < >	A key on the keyboard	Press <Enter>, <F1>
Courier New font:		
Plain Courier New	Sample source code	#define START
	Filenames	autoexec.bat
	File paths	c:\mcc18\h
	Keywords	_asm, _endasm, static
	Command-line options	-Opa+, -Opa-
	Bit values	0, 1
	Constants	0xFF, 'A'
Italic Courier New	A variable argument	<i>file.o</i> , where <i>file</i> can be any valid filename
Square brackets []	Optional arguments	mcc18 [options] <i>file</i> [options]
Curly brackets and pipe character: { }	Choice of mutually exclusive arguments; an OR selection	errorlevel {0 1}
Ellipses...	Replaces repeated text	var_name [, var_name...]
	Represents code supplied by user	void main (void) { ... }

THE MICROCHIP WEB SITE

Microchip provides online support via our web site at www.microchip.com. This web site is used as a means to make files and information easily available to customers. Accessible by using your favorite Internet browser, the web site contains the following information:

- **Product Support** – Data sheets and errata, application notes and sample programs, design resources, user's guides and hardware support documents, latest software releases and archived software
- **General Technical Support** – Frequently Asked Questions (FAQs), technical support requests, online discussion groups, Microchip consultant program member listing
- **Business of Microchip** – Product selector and ordering guides, latest Microchip press releases, listing of seminars and events, listings of Microchip sales offices, distributors and factory representatives

DEVELOPMENT SYSTEMS CUSTOMER CHANGE NOTIFICATION SERVICE

Microchip's customer notification service helps keep customers current on Microchip products. Subscribers will receive e-mail notification whenever there are changes, updates, revisions or errata related to a specified product family or development tool of interest.

To register, access the Microchip web site at www.microchip.com, click on Customer Change Notification and follow the registration instructions.

The Development Systems product group categories are:

- **Compilers** – The latest information on Microchip C compilers, assemblers, linkers and other language tools. These include all MPLAB C compilers; all MPLAB assemblers (including MPASM assembler); all MPLAB linkers (including MPLINK object linker); and all MPLAB librarians (including MPLIB object librarian).
- **Emulators** – The latest information on Microchip in-circuit emulators. This includes the MPLAB REAL ICE and MPLAB ICE 2000 in-circuit emulators.
- **In-Circuit Debuggers** – The latest information on the Microchip in-circuit debuggers. This includes MPLAB ICD 3 in-circuit debuggers and PICkit 3 debug express.
- **MPLAB IDE** – The latest information on Microchip MPLAB IDE, the Windows Integrated Development Environment for development systems tools. This list is focused on the MPLAB IDE, MPLAB IDE Project Manager, MPLAB Editor and MPLAB SIM simulator, as well as general editing and debugging features.
- **Programmers** – The latest information on Microchip programmers. These include production programmers such as MPLAB REAL ICE in-circuit emulator, MPLAB ICD 3 in-circuit debugger and MPLAB PM3 device programmers. Also included are nonproduction development programmers such as PICSTART Plus and PIC-kit 2 and 3.

CUSTOMER SUPPORT

Users of Microchip products can receive assistance through several channels:

- Distributor or Representative
- Local Sales Office
- Field Application Engineer (FAE)
- Technical Support

Customers should contact their distributor, representative or field application engineer (FAE) for support. Local sales offices are also available to help customers. A listing of sales offices and locations is included in the back of this document.

Technical support is available through the web site at:

<http://www.microchip.com/support>

DOCUMENT REVISION HISTORY

Revision A (July 2015)

- Initial Release of this Document.

Chapter 1. Overview

1.1 INTRODUCTION

The LAN9355 is a fully featured, three-port 10/100 managed Ethernet switch designed for industrial and embedded applications where performance, flexibility, ease of integration and system cost control are required.

The LAN9355 combines all the functions of a 10/100 switch system, including the switch fabric, packet buffers, buffer manager, media access controllers (MACs), PHY transceivers, and serial management. IEEE 1588v2 is supported via the integrated IEEE 1588v2 hard-ware time stamp unit, which supports end-to-end and peer-to-peer transparent clocks.

The LAN9355 complies with the IEEE 802.3 (full/half-duplex 10BASE-T and 100BASE-TX) Ethernet protocol, IEEE 802.3az Energy Efficient Ethernet (EEE) (100Mbps only), and 802.1D/802.1Q management protocol specifications, enabling compatibility with industry standard Ethernet and Fast Ethernet applications.

100BASE-FX is supported via an external fiber transceiver and cable diagnostics (open and length) is included on the internal twisted pair copper interface.

The EVB-LAN9355 is an Evaluation Board (EVB) that utilizes the LAN9355 to provide a fully-functional three-port Ethernet switch with Dual MII/RMII/TurboMII. The EVB9355 provides one fully integrated MAC/PHY internet ports (Ports 2) via on-board RJ45 connectors. Port 0 and Port 1 provides two MII port connectors which support the following:

- An external Dual MII/RMII/Turbo MII –Capable MAC (with LAN9355 in PHY mode), via the on-board 40-pin male MII connector
- An external Dual MII/RMII/Turbo MII –Capable PHY (with LAN9355 in MAC mode), via the on-board 40-pin female MII connector

Power is supplied to the board via a +5V external wall mount power supply.

The EVB-LAN9355 includes a 64K x 8 I2C EEPROM that may be used to automatically load configuration settings from the EEPROM into the device at reset. An I2C host adapter interface header (10-pin, 2x5) is provided to simplify I2C based configuration. A simplified block diagram of the EVB LAN9355 can be seen in [Figure 1-1](#).

FIGURE 1-1: EVB-LAN9355 BLOCK DIAGRAM

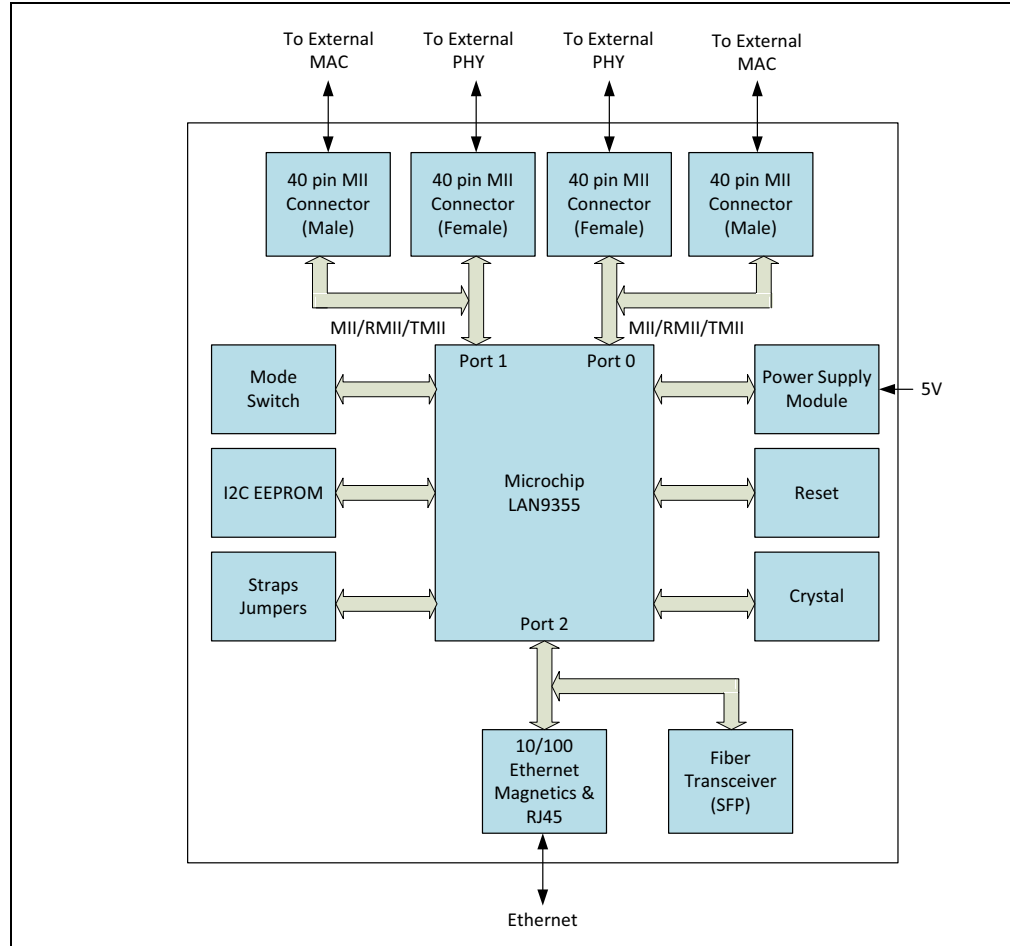

1.1.1 References

Concepts and material available in the following documents may be helpful when reading this document. Visit www.microchip.com for the latest documentation.

Document	Location
LAN9355 datasheet	Visit www.microchip.com
AN8-13 Suggested Magnetics	http://www.microchip.com/wwwAppNotes/AppNotes.aspx?appnote=en562793
EVB-LAN9355 Evaluation Board Schematic	Visit www.microchip.com

1.1.2 Terms and Abbreviations

- **EVB** - Evaluation Board
- **DNP** - Do Not Populate
- **100BASE-TX** - 100 Mbps Fast Ethernet, IEEE802.3u Compliant
- **GPIO** - General Purpose I/O
- **MII** - Media Independent Interface
- **RMII** - Reduced Media Independent Interface
- **EEE** - Energy-Efficient Ethernet
- **SFP** - Small Form-factor Pluggable
- **SFF** - Small Form Factor
- **SMI** - Serial Management Interface

Chapter 2. Board Details

2.1 BOARD DETAILS

The following sections describe the various board features, including jumpers, LEDs, test points, system connections, and switches. A top view of the EVB-LAN9355 is shown in Figure 2-1.

FIGURE 2-1: LAN9355 BOARD REV-A

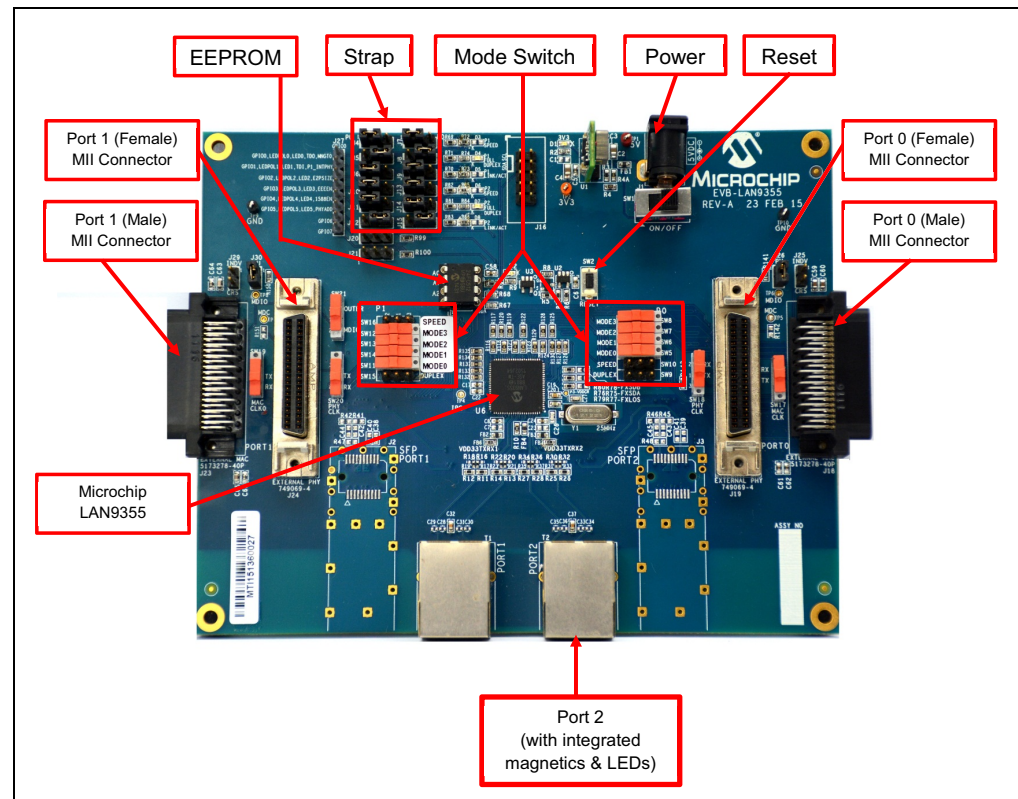

2.1.1 Power

DC 5V is applied through (J1) DC Socket, powered by a +5V external wall adapter switch (SW1) need to be ON position for the 5V to reach the 3.3V regulator. Glowing of Green LED (D1) indicates successful generation of 3.3V o/p. This Power is supplied to the LAN9355 and it has internal 1.2 V regulator which supplies power to the internal core logic.

2.1.2 Power-on Reset

A power-on reset occurs whenever power is initially applied to the LAN9355 or if the power is removed and reapplied to the LAN9355. This event resets all circuitry within the LAN9355. After initial power-on, the LAN9355 can be reset by pressing the reset switch (SW2). The reset LED D2 will assert (red) when the LAN9355 is in reset condition.

For stability, a delay of approximately 180ms is added from the +3.3V o/p to reset release.

2.1.3 Clock

The LAN9355 requires a fixed-frequency 25 MHz clock (± 50 ppm) source for use by the internal clock oscillator and PLL. This is typically provided by attaching a 25 MHz crystal to the OSCI and OSCO pins. Optionally, this clock can be provided by driving the OSCI input pin with a single-ended 25 MHz clock source.

Chapter 3. Board Configuration

3.1 STRAP OPTIONS

The following tables describe the default settings and jumper descriptions for the EVB-LAN9355. These defaults are the recommended configurations for evaluation of the LAN9355. These settings may be changed as needed, however, any deviation from the defaults settings should be approached with care and knowledge of the schematics and datasheet. An incorrect jumper setting may disable the board.

3.1.1 Jumpers J4:J15

Jumpers J4 through J15 set various functions of the LAN9355. They can also be used as GPIOs, LED drivers. When used as LED drivers, as they are on the EVB-LAN9355, they are connected a specific way to set the strap value to a "1", and another way to set the strap value to a "0". Figure 3-1 illustrates the schematics connections with the D3 circuit as a pull-up, and the D4 circuit as a pull-down. To illuminate D3, the LAN9355 will drive the cathode of the D3 low. To illuminate D4, the LAN9355 will drive the cathode of the D4 high.

The J4 - J15 jumpers must be configured in pairs to identical settings in order to realize the D3 circuit or the D4 circuit. The pairings are as follows:

- J4 & J7
- J6 & J9
- J5 & J8
- J11 & J14
- J10 & J13
- J12 & J15

The following subsections detail the jumper pair settings, their associated strap settings, and the functional effects of setting the straps. All strap values are read during power-up and on the rising edge of nRST signal. Once the strap value is set, the LAN9355 will drive the LED's high or low for illumination according the strap value. For other designs which may use these pins as GPIOs refer to LAN9355 datasheet for additional information. In those cases, internal default straps must be changed by an I2C or SMI master or through EEPROM fields.

FIGURE 3-1: LED STRAP CIRCUIT

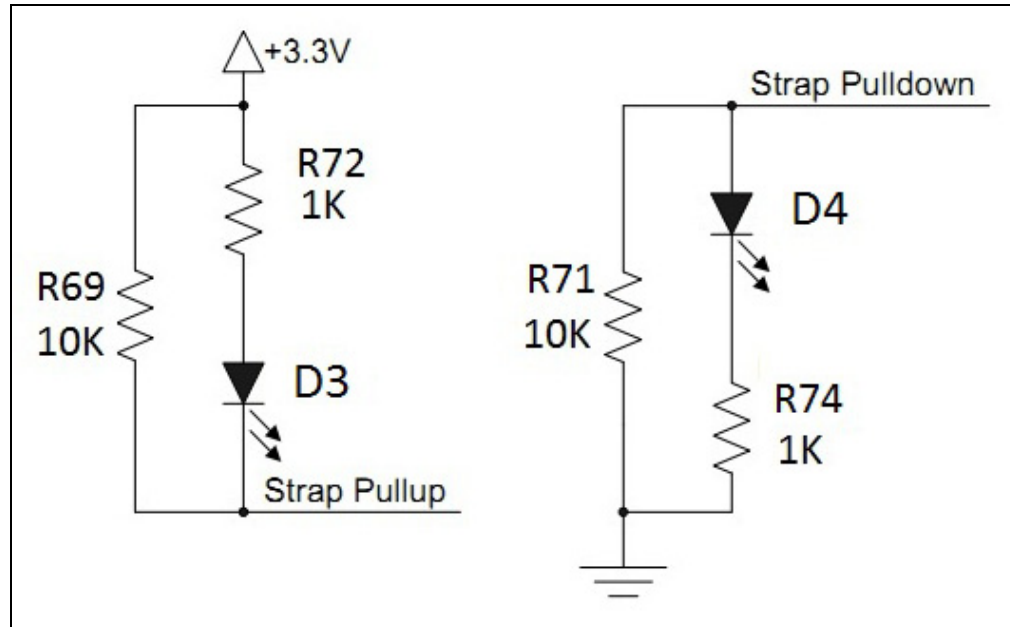

3.1.1.1 GPIO/LED POL/LED CONFIGURATIONS:

GPIO/LED POL/LED configuration straps are used to configure the default polarity of LEDs, GPIOs through jumpers as shown below in Table 3-1.

TABLE 3-1: GPIO/LED POL/LED CONFIGURATIONS

Header	Pin Settings	Signal Name	Strap Value	Description
J4 & J7	1-2(default)	LEDPOL0 /GPIO0 /LED0	1	The LED (D3) is set as active LOW.
	2-3		0	The LED (D3) is set as active HIGH.
J5 & J8	1-2(default)	LEDPOL1 /GPIO1 /LED1	1	The LED (D4) is set as active LOW.
	2-3		0	The LED (D4) is set as active HIGH.
J6 & J9	1-2(default)	LEDPOL2 /GPIO2 /LED2	1	The LED (D5) is set as active LOW.
	2-3		0	The LED (D5) is set as active HIGH.
J10 & J13	1-2(default)	LEDPOL3 /GPIO3 /LED3	1	The LED (D6) is set as active LOW.
	2-3		0	The LED (D6) is set as active HIGH.

TABLE 3-1: GPIO/LED POL/LED CONFIGURATIONS (CONTINUED)

Header	Pin Settings	Signal Name	Strap Value	Description
J11 & J14	1-2(default)	LEDPOL4 /GPIO4 /LED4	1	The LED (D7) is set as active LOW.
	2 -3		0	The LED (D7) is set as active HIGH.
J12 & J15	1-2(default)	LEDPOL5 /GPIO5 /LED5	1	The LED (D8) is set as active LOW.
	2 -3		0	The LED (D8) is set as active HIGH.

3.1.1.2 SERIAL MANAGEMENT MODE CONFIGURATION

Serial Management Mode selection strap (MNGT0) is used to configure the default value of the Serial Management Mode Strap hard-strap (serial_mngt_mode_strap) through jumpers as shown below in Table 3-2.

TABLE 3-2: SERIAL MANAGEMENT MODE CONFIGURATION

Header	Pin Settings	serial_mngt_mode_strap	Description
J4 & J7	2-3	0	SMI Managed Mode
J4 & J7	1-2 (default)	1	I2C Managed Mode

3.1.1.3 EEPROM SIZE CONFIGURATION:

The EEPROM size configuration strap (J6 & J9) determines the supported EEPROM size range. A low selects 1Kbits (128 x 8) through 16Kbits (2K x 8)_24C16. A high selects 32Kbits (4K x 8) through 512Kbits (64K x 8) or 4Mbits (512K x 8)_24C512 as shown below in Table 3-3.

TABLE 3-3: EEPROM SIZE CONFIGURATION

Header	Pin Settings	eprom_size_strap Value	Description
J6 & J9	1-2 (default)	1	EEPROM size = 32K bits (4k x 8) through 512K bits (64K x 8)
	2 -3	0	EEPROM size = 1K bits (128 x 8) through 16K bits (2K x 8)

3.1.1.4 ENERGY-EFFICIENT ETHERNET CONFIGURATION

EEEEEE_ENEN configuration strap is used to configure the default value of the EEE Enable 2-1 soft-straps (EEE_enable_strap_[2:1]) through jumpers as shown below in Table 3-4.

Note: “EEE_enable_strap_1” strap is used for the LAN9355 when in Port 1 internal PHY mode.

TABLE 3-4: EEE_EN CONFIGURATION

Header	Pin Settings	EEE_enable_strap_[2:1] Value	Description
J10 & J13	1-2(default)	1	EEE Enable
	2-3	0	EEE Disable

3.1.1.5 1588 ENABLE CONFIGURATION

Energy Efficient Ethernet configuration strap is used to configure the default value of the 1588 Enable soft-strap (1588_enable_strap) through jumpers as shown below in Table 3-5.

TABLE 3-5: 1588 ENABLE CONFIGURATION

Header	Pin Settings	1588_enable_strap Value	Description
J11 & J14	1-2 (default)	1	1588 Enable
	2-3	0	1588 Disable

3.1.1.6 PHY ADDRESS CONFIGURATION

PHY Address selection strap is used to configure the default value of the Switch PHY Address Select soft-strap (phy_addr_sel_strap) through jumpers as shown below in Table 3-6.

TABLE 3-6: PHY ADDRESSING

Header	Pin Settings	PHY_ADDR_SEL_STRAP Value	VIRTUAL PHY 0 AND 1 DEFAULT ADDRESS VALUE	PHY A DEFAULT ADDRESS VALUE	PHY B DEFAULT ADDRESS VALUE
J12 & J15	1-2	1	1	2	3
	2-3 (default)	0	0	1	2

3.1.2 GPIO 6 & GPIO 7 Input and Output Configurations

GPIO 6 & 7 configuration straps are used to configure the default input value of the GPIO 6 and 7 through jumpers as shown below in Table 3-7 and Table 3-8.

TABLE 3-7: GPIO 6 & 7 INPUT CONFIGURATION

Header	Pin Settings	Input	Signal Name
J20	1-2	1	GPIO6
	2-3	0	
J21	1-2	1	GPIO7
	2-3	0	

TABLE 3-8: GPIO 6 & 7 OUTPUT CONFIGURATION

Header	Pin	Output	Signal Name
J20	2	Push Pull	GPIO6
J21	2	Push Pull	GPIO7

Note: By default, the jumpers settings for J20 & J21 will be OPEN.

3.1.3 Link Partner Duplex/Speed Configurations

The “duplex_strap_0” strap from SW9 is used to determine the link partners duplex ability when in Port 0 MII MAC and RMII MAC modes.

The “speed_strap_0” strap from SW10 is used to determine the link partners speed ability and to determine the parallel detect speed when in Port 0 MII MAC and RMII MAC modes, as shown below in Table 3-9.

TABLE 3-9: EMULATED LINK PARTNER DEFAULT ADVERTISED ABILITY FOR PORT 0

SW9 (P0_DUPLEX)	SW10 (P0_SPEED)	duplex_strap_0	speed_strap_0	ADVERTISED LINK PARTNER ABILITY
1-2	1-3	1	0	10BASE-T full-duplex (0010)
1-2	1-2	1	1	100BASE-X full-duplex (1000)
1-3	1-3	0	0	10BASE-T half-duplex (0001) (Default)
1-3	1-2	0	1	100BASE-X half-duplex (0100)

Note: For Switches to short 1-3, Knob Position should be at 1-2 and vice versa.

The “duplex_strap_1” strap from SW15 is used to determine the link partners duplex ability when in Port 1 MII MAC and RMII MAC modes.

The “speed_strap_1” strap from SW16 is used to determine the link partners speed ability and to determine the parallel detect speed when in Port 1 MII MAC and RMII MAC modes, as shown below in Table 3-10.

TABLE 3-10: EMULATED LINK PARTNER DEFAULT ADVERTISED ABILITY FOR PORT 1

SW15 (P1_DUPLEX)	SW16 (P1_SPEED)	duplex_strap_0	speed_strap_0	ADVERTISED LINK PARTNER ABILITY
1-2	1-3	1	0	10BASE-T full-duplex (0010)
1-2	1-2	1	1	100BASE-X full-duplex (1000)
1-3	1-3	0	0	10BASE-T half-duplex (0001) (Default)
1-3	1-2	0	1	100BASE-X half-duplex (0100)

Note: For Switches to short 1-3, Knob Position should be at 1-2 and vice versa.

3.1.4 Port 0/Port 1 Mode Configurations

Port 0 Mode configuration straps (SW5, SW6, SW7 & SW8) are used to configure the hard-straps such as Switch Port 0 Mode Strap (P0_mode_strap[1:0]), Switch Port 0 RMII Clock Direction Strap (P0_rmii_clock_dir_strap) and Switch Port 0 Clock Strength Strap (P0_clock_strength_strap) as shown below in Table 3-11.

TABLE 3-11: PORT 0 MODE STRAP MAPPING

P0_MODE3 (SW8)	P0_MODE2 (SW7)	P0_MODE1 (SW6)	P0_MODE0 (SW5)	MODE
1-3	1-3	X	X	MII MAC (default)
1-3	1-2	1-3	X	MII PHY
1-3	1-2	1-2	1-3	Turbo MII PHY 12 ma
1-3	1-2	1-2	1-2	Turbo MII PHY 16 ma
1-2	1-3	1-3	X	RMII MAC clock in
1-2	1-3	1-2	1-3	RMII MAC clock out 12ma
1-2	1-3	1-2	1-2	RMII MAC clock out 16ma
1-2	1-2	1-3	X	RMII PHY clock in
1-2	1-2	1-2	1-3	RMII PHY clock out 12ma
1-2	1-2	1-2	1-2	RMII PHY clock out 16ma

Note: For Switches to short 1-3, Knob Position should be at 1-2 and vice versa.

Port 1 Mode configuration straps (SW11, SW14, SW13 & SW12) are used to configure the hard-straps such as Switch Port 1 Mode Strap (P1_mode_strap[1:0]), Switch Port 1 RMII Clock Direction Strap (P1_rmii_clock_dir_strap) and Switch Port 1 Clock Strength Strap (P1_clock_strength_strap) as shown below in Table 3-12.

TABLE 3-12: PORT 1 MODE STRAP MAPPING

P1_INTPHY (J5 & J8)	P1_MODE3 (SW12)	P1_MODE2 (SW13)	P1_MODE1 (SW14)	P1_MODE0 (SW11)	MODE
2-3	1-3	1-3	X	X	MII MAC (default)
2-3	1-3	1-2	1-3	X	MII PHY
2-3	1-3	1-2	1-2	1-3	Turbo MII PHY 12 ma
2-3	1-3	1-2	1-2	1-2	Turbo MII PHY 16 ma
2-3	1-2	1-3	1-3	X	RMII MAC clock in
2-3	1-2	1-3	1-2	1-3	RMII MAC clock out 12ma
2-3	1-2	1-3	1-2	1-2	RMII MAC clock out 16ma
2-3	1-2	1-2	1-3	X	RMII PHY clock in
2-3	1-2	1-2	1-2	1-3	RMII PHY clock out 12ma
2-3	1-2	1-2	1-2	1-2	RMII PHY clock out 16ma
1-2	X	X	X	X	Internal PHY

Note: For Switches to short 1-3, Knob Position should be at 1-2 and vice versa.

3.1.5 RMII RX Clock Configurations

When LAN9355 is in MAC/PHY mode the reference clock routed either through TX or RX Clock as shown in Table 3-13.

TABLE 3-13: RX CLOCK CONFIGURATIONS FOR PORT 0

Switch Settings	DESCRIPTION	Mode
SW19 (1-3) (Default)	TX Clock used as a Reference Clock	RMII MAC
SW19 (1-2)	RX Clock used as a Reference Clock	RMII MAC
SW20 (1-3) (Default)	Reference clock used as a TX clock	RMII PHY
SW20 (1-2)	Reference clock used as a RX clock	RMII PHY

3.1.6 GPIO Header

J27 connector is used for GPIO header. Respective pin details are given below in Table 3-14.

TABLE 3-14: PIN NAMES FOR GPIO HEADER

Signal Name	Pin Number
GPIO0	J27.1
GPIO1	J27.2
GPIO2	J27.3
GPIO3	J27.4
GPIO4	J27.5
GPIO5	J27.6
GPIO6	J27.7
GPIO7	J27.8

3.1.7 I2C Aardvark® Header

J16 connector is used for I2C Aardvark header. Respective pin details are given below in Table 3-15.

TABLE 3-15: PIN NAMES FOR I2C AARDVARK HEADER

Signal Name	Pin Number
I2C2_SCL	J16.1
I2C2_SDA	J16.3
GND	J16.2 & J16.10

3.1.8 Copper and Fiber Mode Selections

The LAN9355 supports 100BASE-TX (Copper) and 100BASE-FX (Fiber) modes. In 100BASE-FX operation, the presence of the receive signal is indicated by the external transceiver as either an open-drain, CMOS level, Loss of Signal (SFF) or a LVPECL Signal Detect (SFF).

This EVB supports 100BASE-TX (Copper) and 100BASE-FX (Fiber) in SFP mode. By default Copper Mode is active. Fiber Mode is supported as an assembly option. To select the Copper or Fiber Mode, the respective strap and signal routing resistor assembly options must to be configured.

Note: Vendor part number for SFP Transceiver: Finisar/FTLF1217P2.

3.1.8.1 COPPER MODE

The EVB-LAN9355 is set to Copper Mode by default. Table 3-16 details the required strap resistors settings for Copper Mode operation.

TABLE 3-16: COPPER MODE STRAP RESISTORS

Resistors	Signal Names	Description
R79 (10K)	FXLOSEN	Copper twisted pair for ports A and B further determined by FXSDENA and FXSDENB
R76, R80 (10K)	FXSDA/FXSDB	Configures Port 0 and Port 1 to Copper Mode

Note: R75, R77, and R78 must not be populated (DNP).

Additionally, the signal routing resistors detailed in Table 3-17 must be assembled for Copper Mode operation.

TABLE 3-17: COPPER MODE SIGNAL ROUTING RESISTORS

Resistors	Description
R17, R19, R21, R23	Port 0 Copper mode is Enabled
R31, R33, R35, R37	Port 1 Copper mode is Enabled

Note: R16, R18, R20, R22, R30, R32, R34, and R36 (0402 package) must not be populated (DNP).

3.1.8.2 FIBER MODE

The LAN9355 supports SFP type 100BASE-FX mode. To enable Fiber Mode, the respective strap and signal routing resistors must be configured.

Note: Copper Mode related resistors must be DNP while Fiber Mode is active (See **Section 3.1.8.1 “Copper Mode”**).

Table 3-18 details the required strap resistor settings for Fiber Mode operation.

TABLE 3-18: FIBER MODE STRAP RESISTORS

Resistors	Description
R77 (10K)	Configures Port 0 & 1 to FX_LOS Mode
R75, R78 (10K)	Configures Port 0 & 1 to Fiber mode, respectively

Note: R76, R79, and R80 must not be populated (DNP).

Additionally, the signal routing resistors detailed in Table 3-19 must be assembled for Fiber Mode operation.

TABLE 3-19: FIBER MODE SIGNAL ROUTING RESISTORS

Resistors	Description
R16, R18, R20, R22	Port 0 Fiber mode Enabled
R30, R32, R34, R36	Port 1 Fiber mode Enabled

Note: R17, R19, R21, R23, R31, R33, R35, and R37 (0402 package) must not be populated (DNP).

3.1.8.3 FX-LOS FIBER MODE STRAP

FX-LOS strap details are shown in Table 3-20. These strap settings determine if the ports are to operate in FX-LOS Fiber Mode or FX-SD/Copper Mode.

TABLE 3-20: FX-LOS MODE STRAP SETTINGS

R77 (10K)	R79 (10K)	Reference Voltage (v)	Function
Populate	DNP	3.3	A level above 2V selects FX-LOS for Port 0 and Port 1
Populate	Populate	1.5	A level of 1.5V selects FX-LOS for Port 0 and FX-SD / Copper twisted pair for Port 1, further determined by FXSDB
DNP	Populate	0 (Default)	A level of 0V selects FX-SD / Copper twisted pair for Ports 0 and 1, further determined by FXSDA, FXSDB

Note: The above strap details describe the LAN9355 function. This EVB does not support SFF Fiber Mode. Therefore, FX-SD related straps are not applicable.

3.2 LEDS

Table 3-21 describes the different LED references and their corresponding colors and indications.

TABLE 3-21: LEDS

Reference	Color	Indication
D1	Green	3.3V Power active
D2	Red	LAN9355 is in reset condition
D4	Green	Full-duplex / Collision Port 1
D6	Green	Full-duplex / Collision Port 2

Note: Assumes the LED_FUN field of the LED_CFG register is 00b.

3.3 TEST POINTS

Table 3-22 describes the different test points and their corresponding connections.

TABLE 3-22: TEST POINTS

Test Points	Description	Connection
TP1	Single pin populated 5V	5V_EXT
TP2	Single pin populated 3V3	3V3
TP3	Single pin unpopulated VDDCR	VDDCR

TABLE 3-22: TEST POINTS

Test Points	Description	Connection
TP4	Single pin unpopulated IRQ	IRQ
TP5	Single pin unpopulated P0_MDC	P0_MDC
TP6	Single pin unpopulated P0_MDIO	P0_MDIO
TP7	Single pin unpopulated P1_MDC	P1_MDC
TP8	Single pin unpopulated P1_MDIO	P1_MDIO
TP9	Single pin populated GND	GND
TP10	Single pin populated GND	GND

3.4 MECHANICALS

Figure 3-2 displays details for EVB-LAN9355 mechanical dimensions. Dimensions are in mm.

FIGURE 3-2: LAN9355 EVB MECHANICAL DIMENSIONS

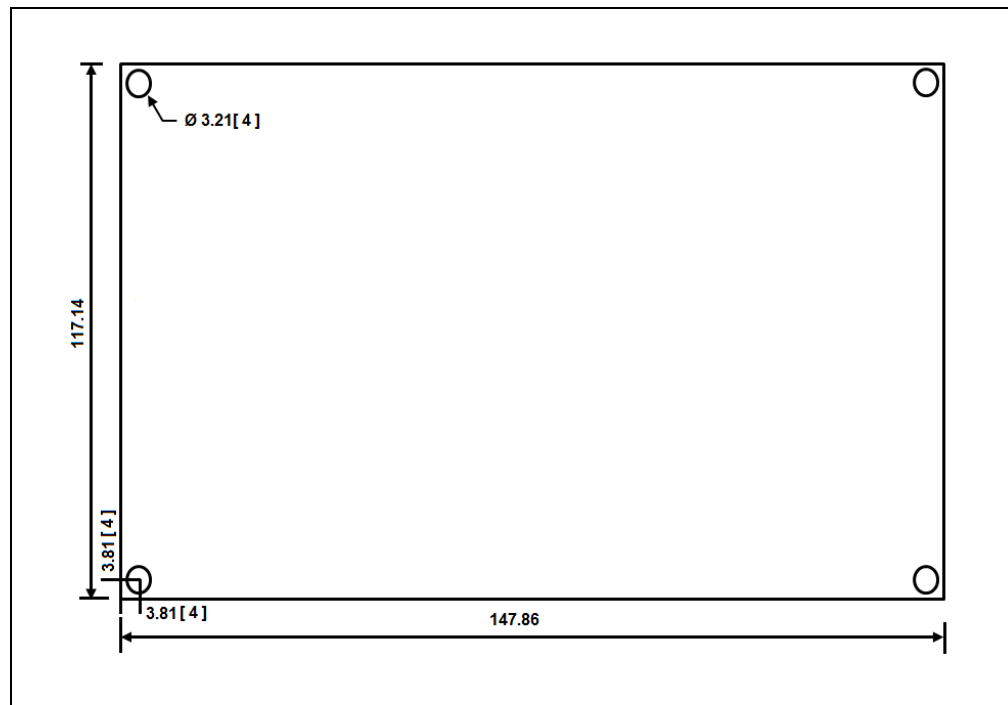

Appendix A. EVB-LAN9355 Evaluation Board

A.1 INTRODUCTION

This appendix shows the EVB-LAN9355 Evaluation Board.

FIGURE A-1: EVB-LAN9355 EVALUATION BOARD

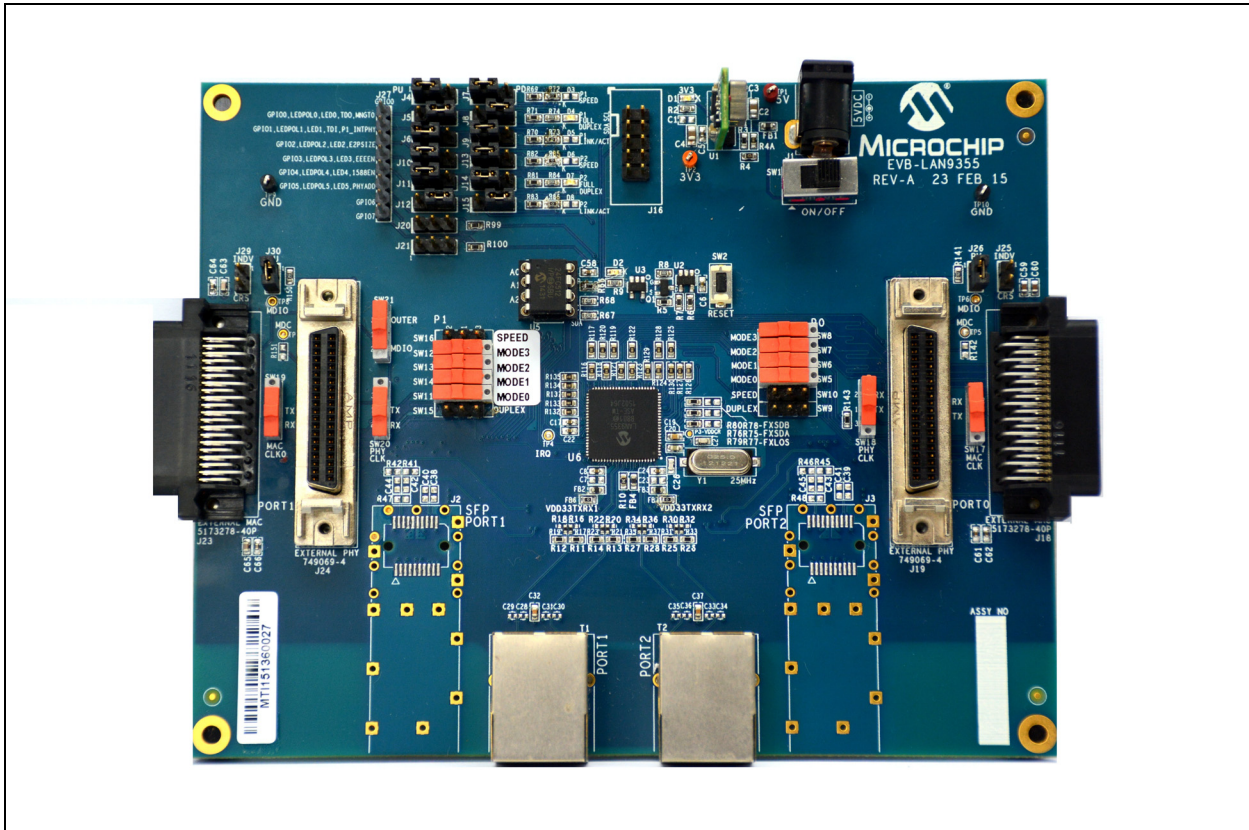



Appendix B. EVB-LAN9355 Evaluation Board Schematics

B.1 INTRODUCTION

This appendix shows the EVB-LAN9355 Evaluation Board Schematics.

FIGURE B-1: EVB-LAN9355 EVALUATION BOARD SCHEMATIC 1

EVB-LAN9355 Block Diagram

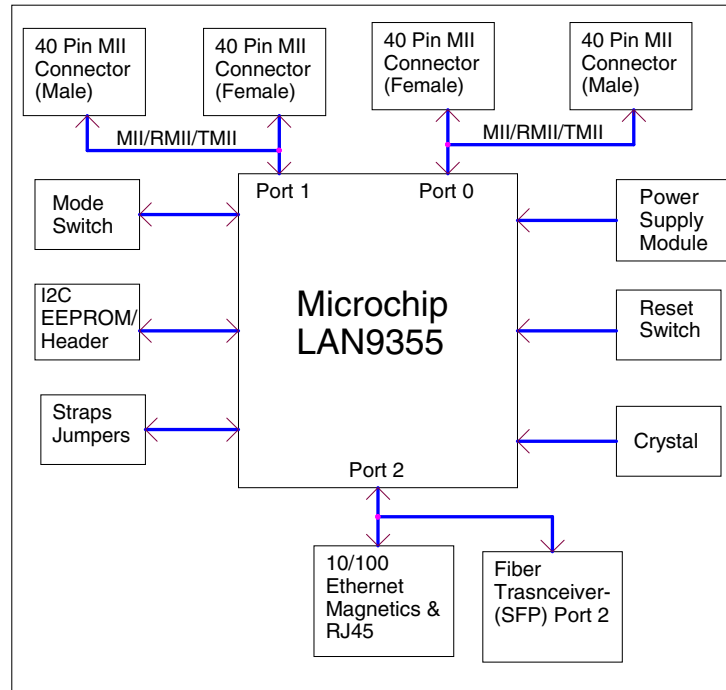

FIGURE B-2: EVB-LAN9355 EVALUATION BOARD SCHEMATIC 2

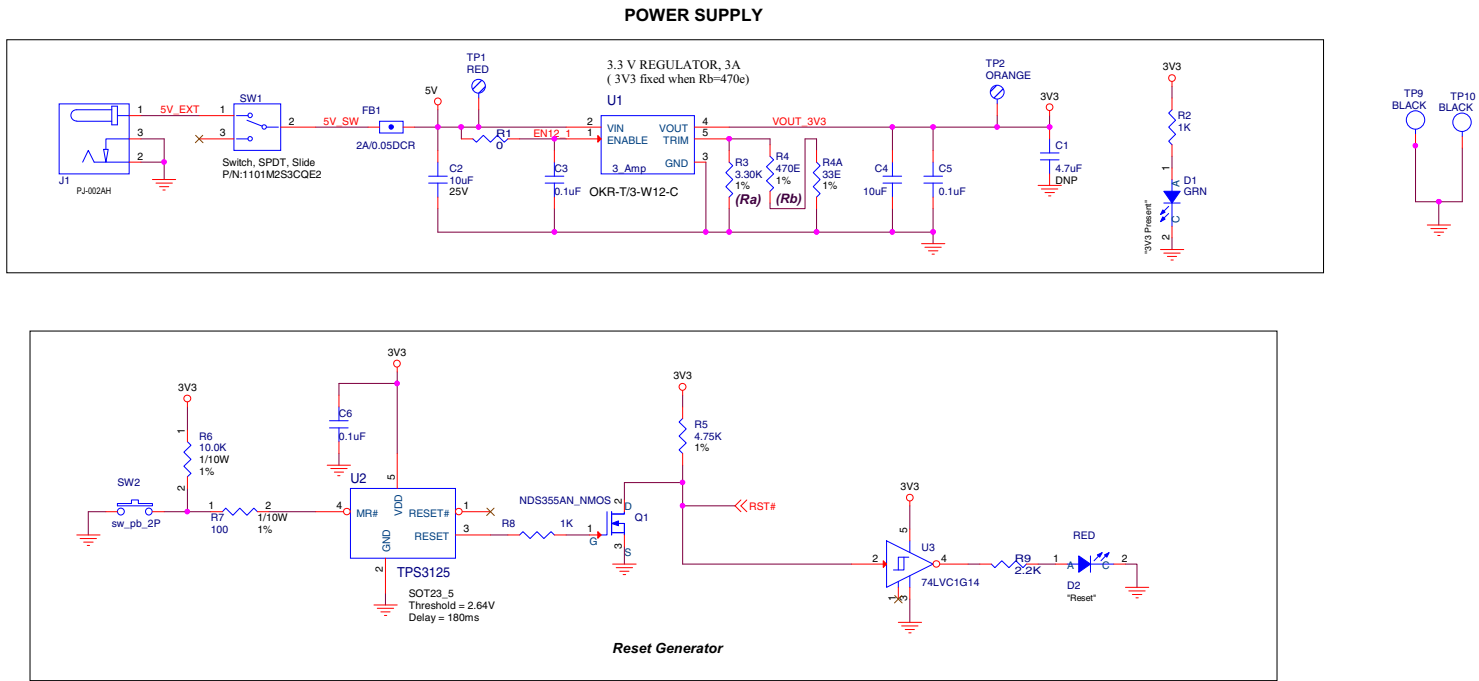
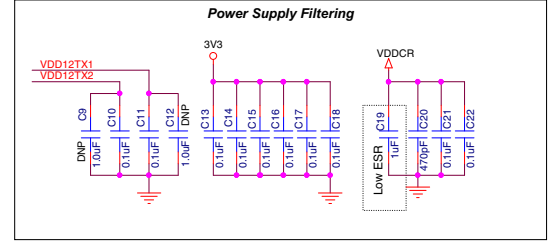
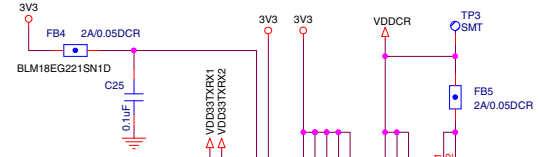
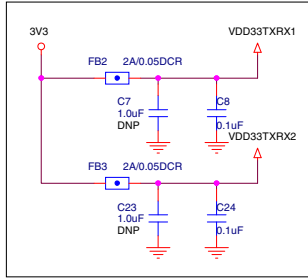

FIGURE B-3: EVB-LAN9355 EVALUATION BOARD SCHEMATIC 3



Note: OSCVSS need to connect to Chip grd.

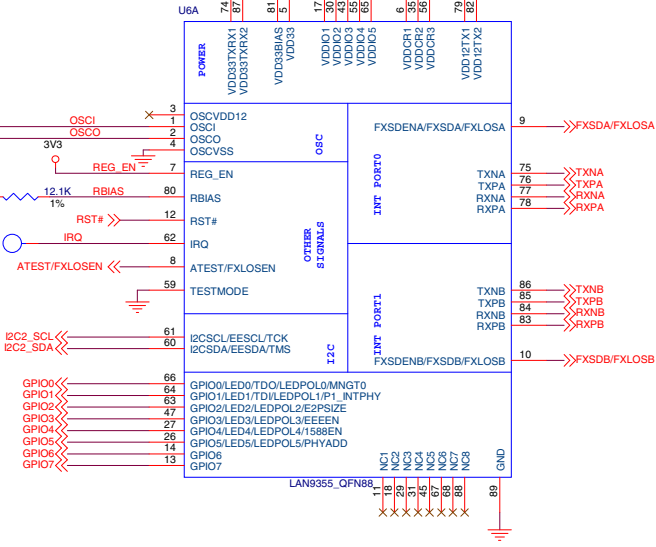
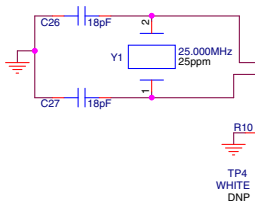

FIGURE B-4: EVB-LAN9355 EVALUATION BOARD SCHEMATIC 4

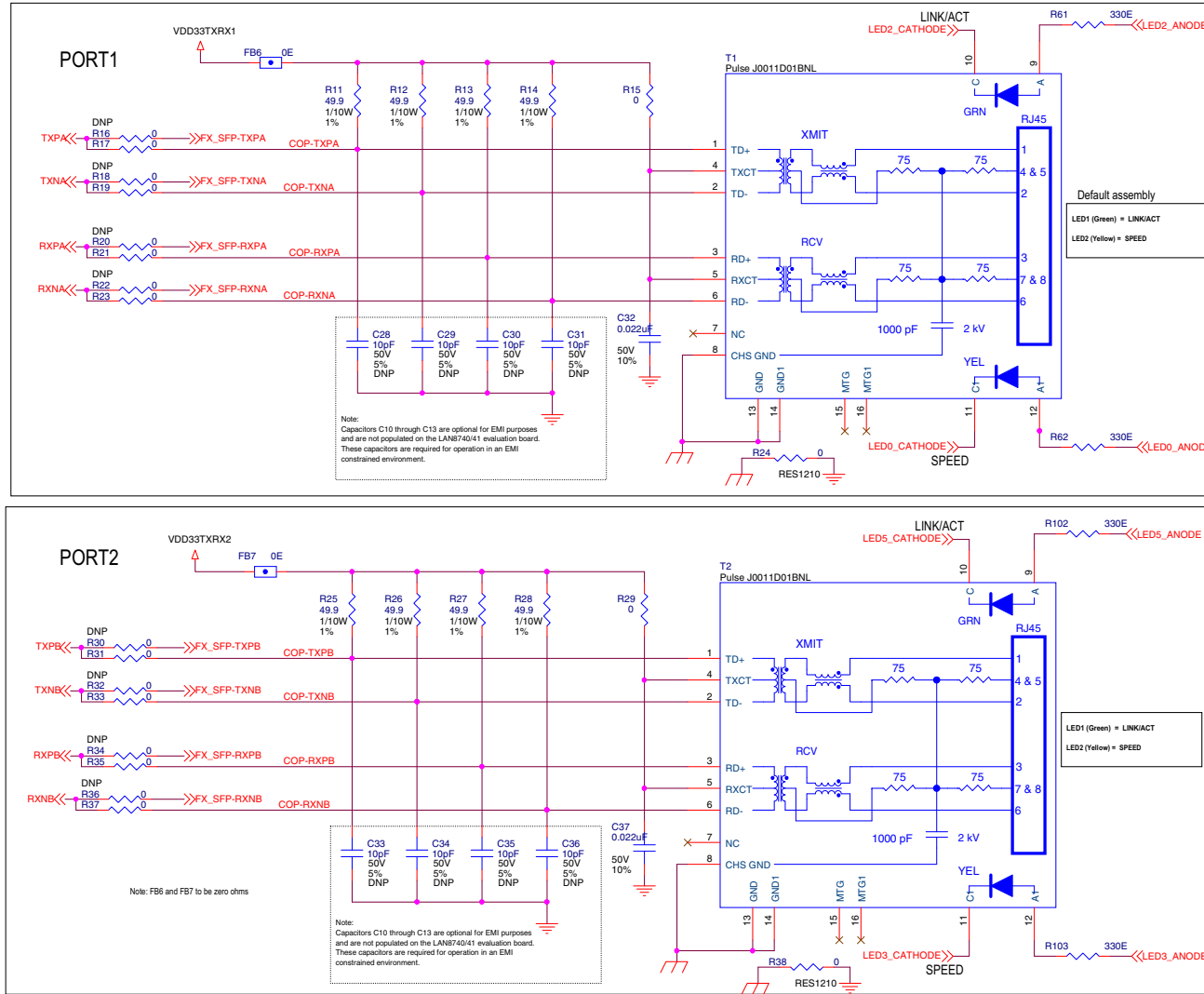
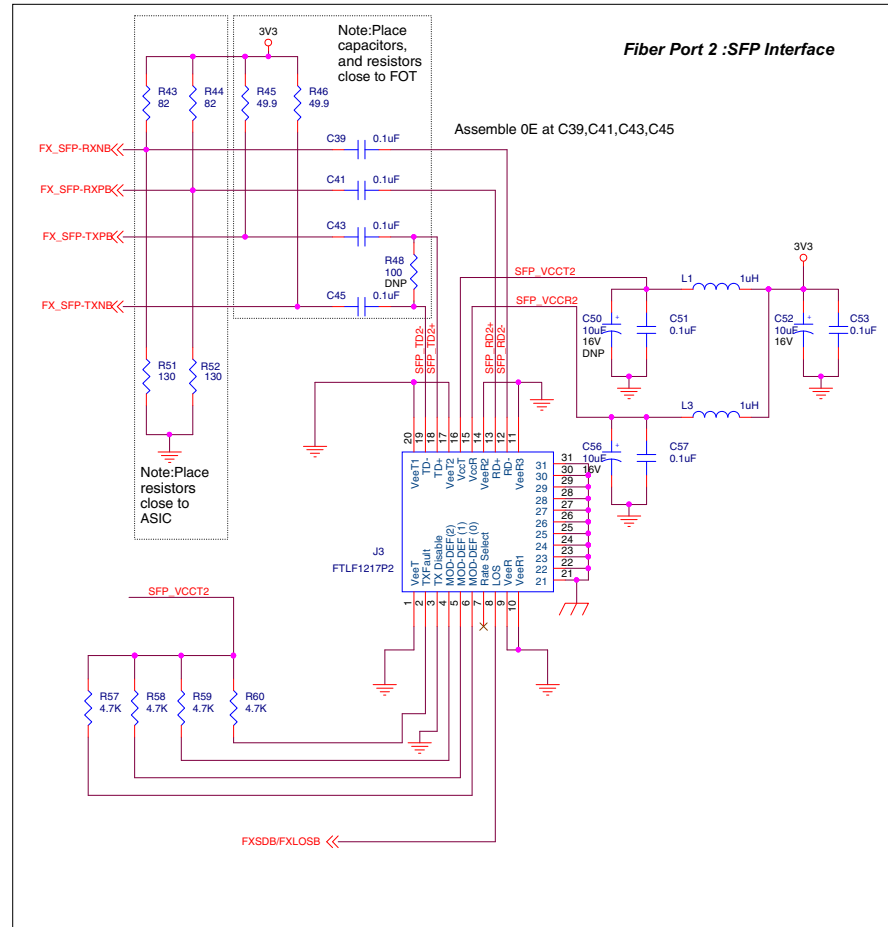
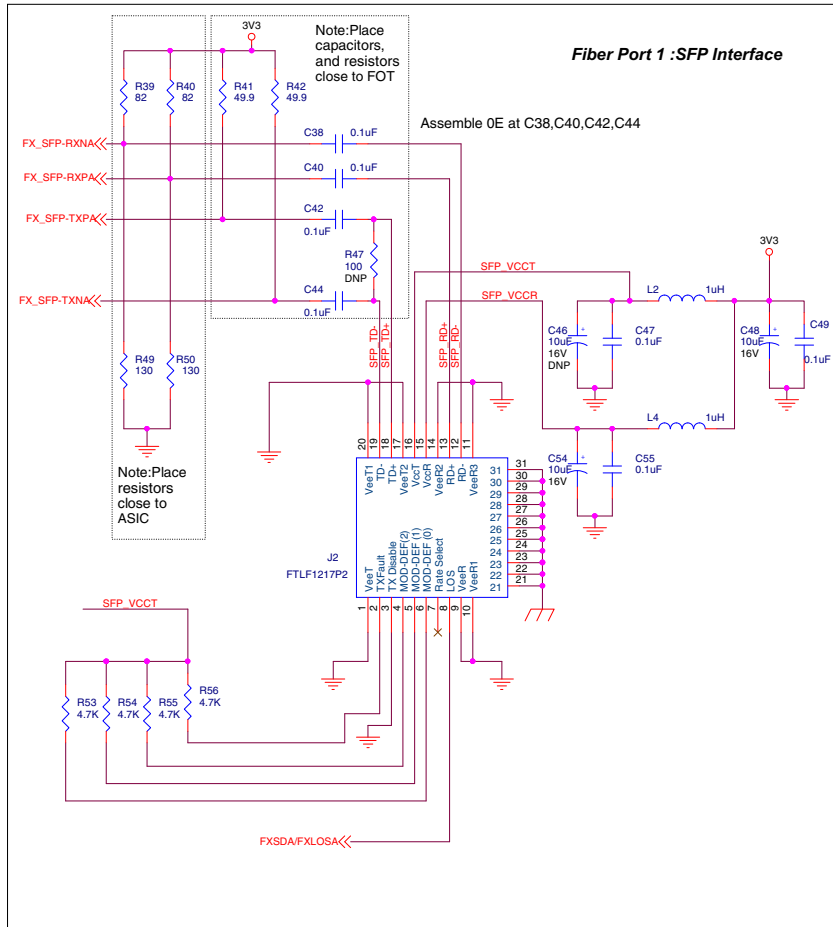

FIGURE B-5: EVB-LAN9355 EVALUATION BOARD SCHEMATIC 5



Note: Fiber mode related components are Not Populated on EVB (Default)

FIGURE B-6: EVB-LAN9355 EVALUATION BOARD SCHEMATIC 6

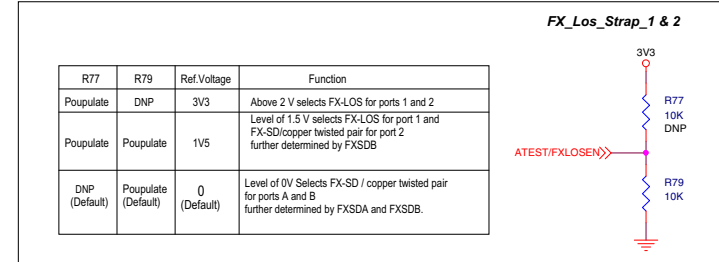
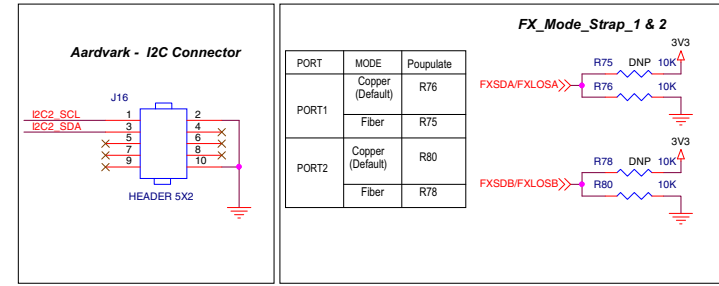
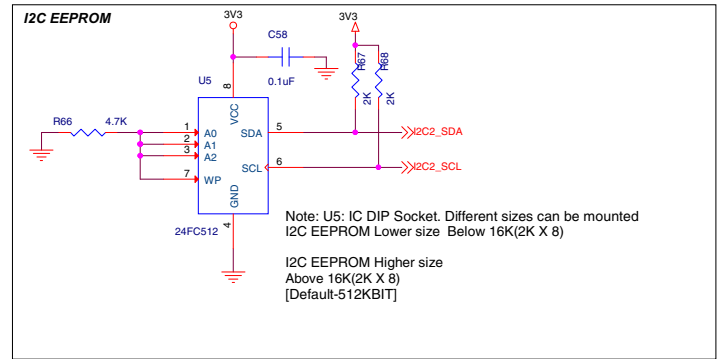
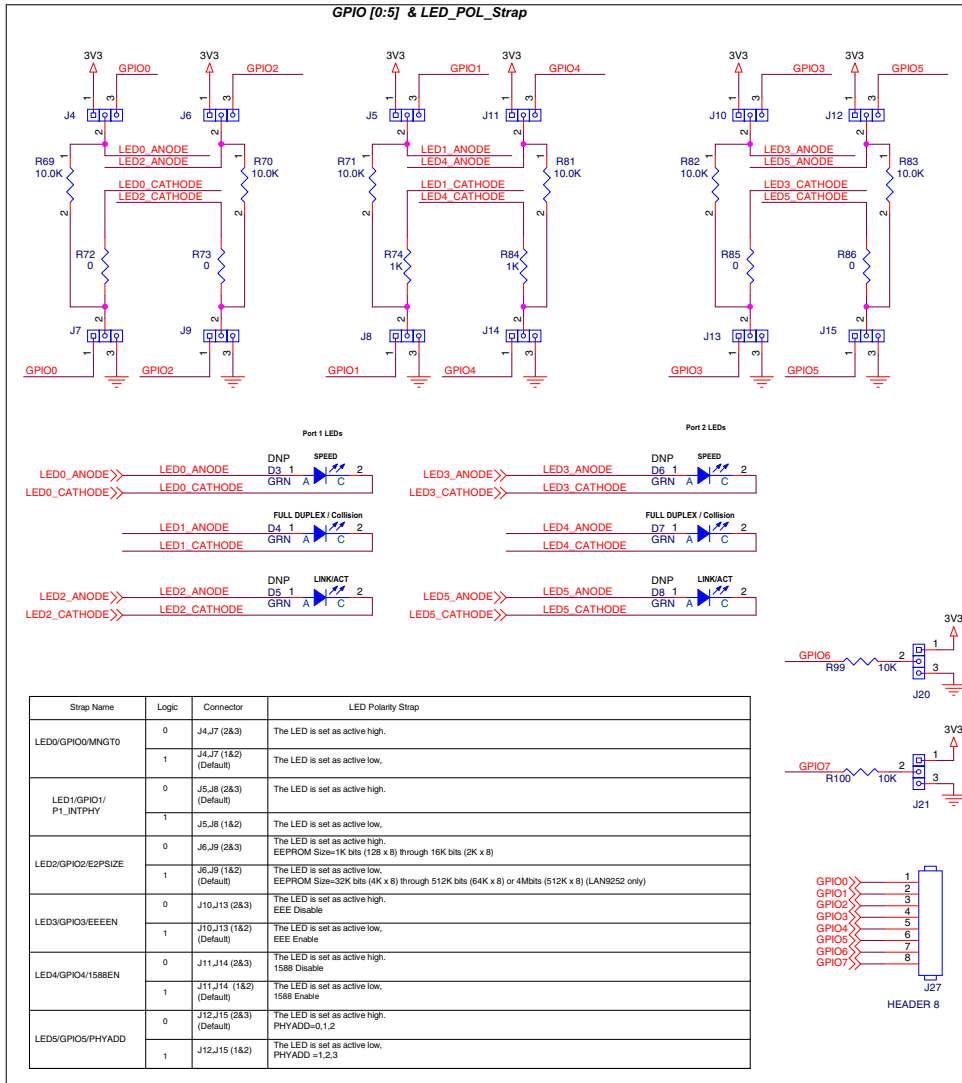
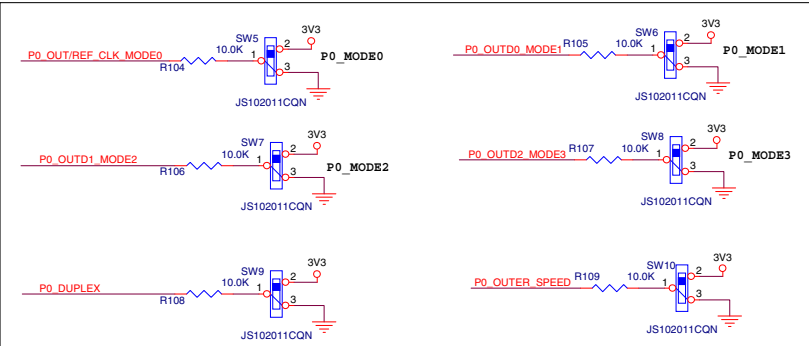

FIGURE B-7: EVB-LAN9355 EVALUATION BOARD SCHEMATIC 7



Note: For Switches to short 1-3, Knob Position should be at 1-2 and vice versa .

PORT 0 MODE STRAP MAPPING

P1_INTPHY (J5 & J8)	P0_MODE3 (SW9)	P0_MODE2 (SW7)	P0_MODE1 (SW6)	P0_MODE0 (SW5)	Port 0 Mode
x	0	0	x	x	MII MAC (Default)
x	0	1	0	x	MII PHY
x	0	1	1	0	Turbo MII PHY 12 ma
x	0	1	1	1	Turbo MII PHY 16 ma
x	1	0	0	x	RMII MAC clock in
x	1	0	1	0	RMII MAC clock out 12ma
x	1	0	1	1	RMII MAC clock out 16ma
x	1	1	0	x	RMII PHY clock in
x	1	1	1	0	RMII PHY clock out 12ma
x	1	1	1	1	RMII PHY clock out 16ma

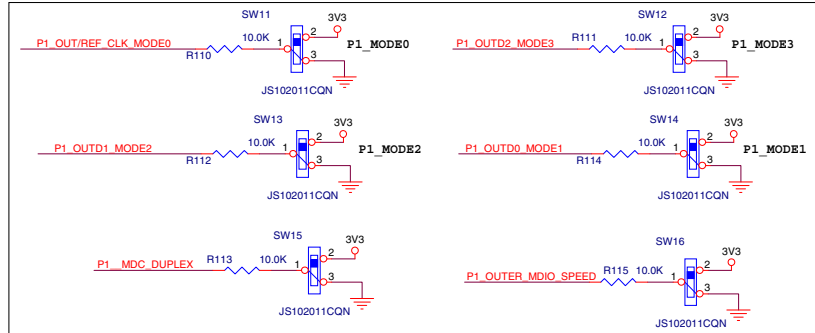

Note: For Switches to short 1-3, Knob Position should be at 1-2 and vice versa .

PORT 1 MODE STRAP MAPPING

P1_INTPHY (J5 & J8)	P1_MODE3 (SW12)	P1_MODE2 (SW13)	P1_MODE1 (SW14)	P1_MODE0 (SW11)	Port 1 Mode
0	0	0	x	x	MII MAC (Default)
0	0	1	0	x	MII PHY
0	0	1	1	0	Turbo MII PHY 12 ma
0	0	1	1	1	Turbo MII PHY 16 ma
0	1	0	0	x	RMII MAC clock in
0	1	0	1	0	RMII MAC clock out 12ma
0	1	0	1	1	RMII MAC clock out 16ma
0	1	1	0	x	RMII PHY clock in
0	1	1	1	0	RMII PHY clock out 12ma
0	1	1	1	1	RMII PHY clock out 16ma
1	x	x	x	x	Internal PHY

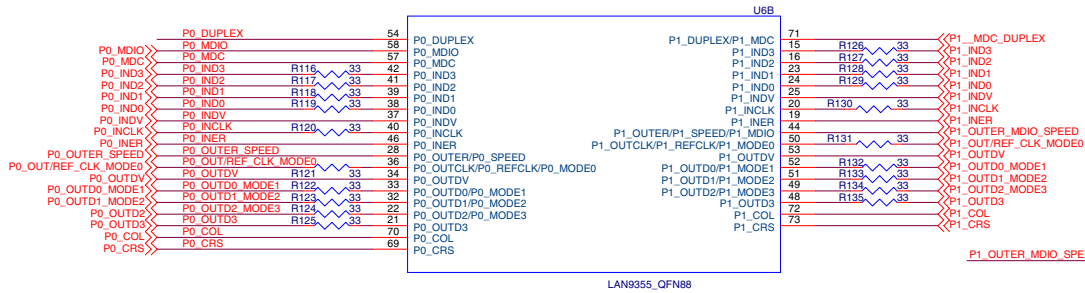

Emulated Link Partner Default Advertised Ability

SW9 (P0_DUPLEX) / SW15 (P1_DUPLEX)	SW10 (P0_SPEED) / SW16 (P1_SPEED)	ADVERTISED LINK PARTNER ABILITY (Bits 8,7,6,5)
1	0	10BASE-T full-duplex (0010)
1	1	100BASE-X full-duplex (1000) (Default)
0	0	10BASE-T half-duplex (0001)
0	1	100BASE-X half-duplex (0100)

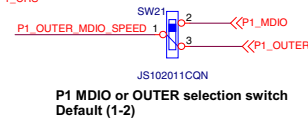

P1 MDIO or OUTER selection switch Default (1-2)

FIGURE B-8: EVB-LAN9355 EVALUATION BOARD SCHEMATIC 8

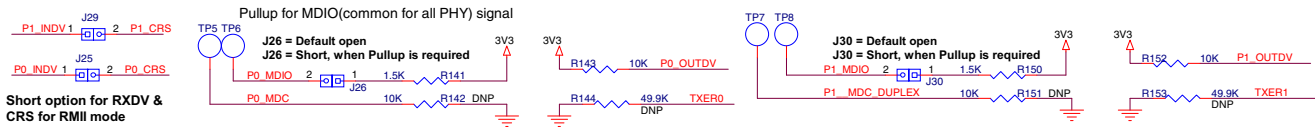
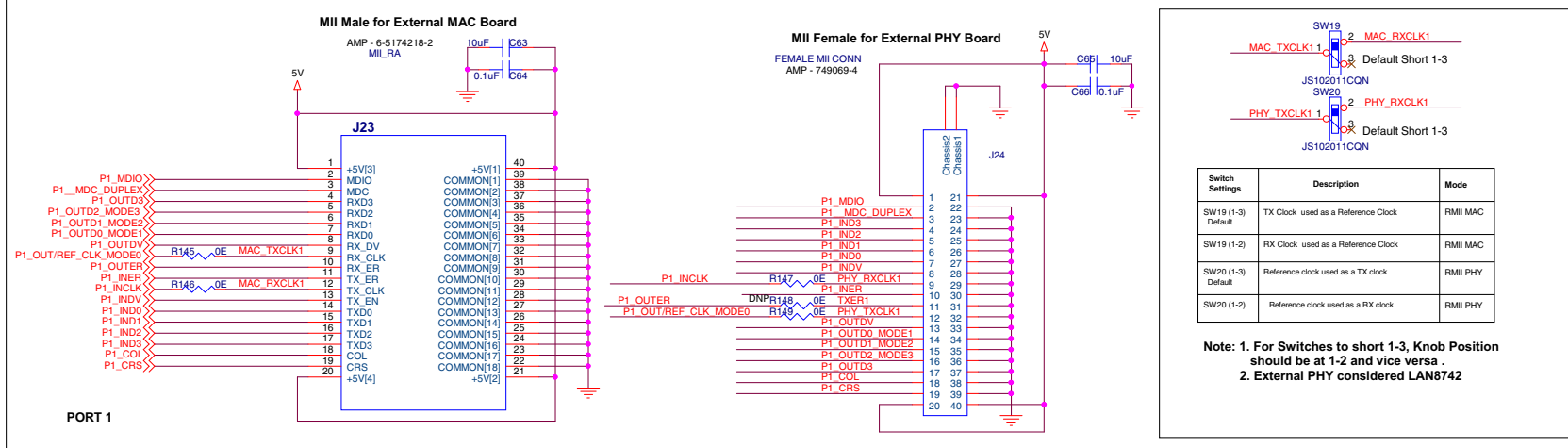
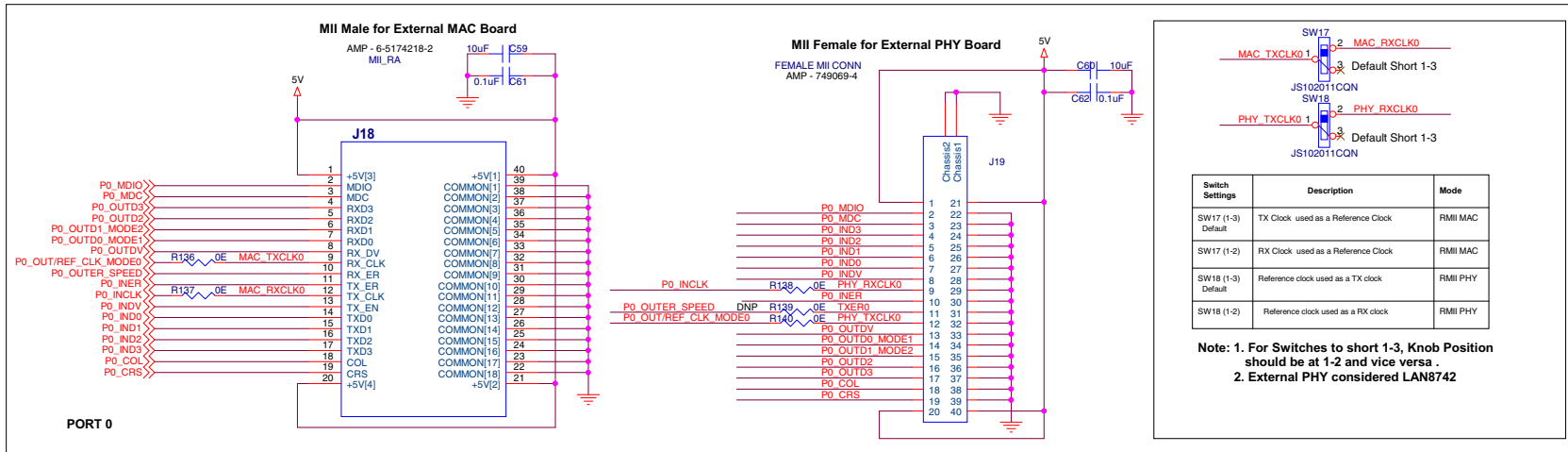



Appendix C. Bill of Materials (BOM)

C.1 INTRODUCTION

This appendix includes the EVB-LAN9355 Evaluation Board Bill of Materials (BOM).

Configuration: One internal copper mode with higher size EEPROM (24FC512)

TABLE C-1: EVB-LAN9355 EVALUATION BOARD BILL OF MATERIALS

Item	Qty	Reference Designator(s)	Part	PCB Footprint	Manufacturer	Manufacturer Part Number
1	2	C2,C4	10uF	CAP0805	Murata	GRM21BR61E106KA73L
2	21	C3,C5,C6,C8,C10,C11,C13,C14,C15,C16,C17,C18,C21,C22,C24,C25,C58,C61,C62,C64,C66	0.1uF	CAP0603	Murata	GRM155R61E104KA7D
3	1	C19	1uF	CAP0603	Murata	GRM188R61C105KA93D
4	1	C20	470pF	CAP0603	Murata	GRM033R71E471KA01D
5	2	C26,C27	18pF	CAP0603	Murata	GRM1885C1H180JA01D
6	2	C32,C37	0.022uF	CAP0603	Kemet	C0603C223K5RACTU
7	4	C59,C60,C63,C65	10uF	CAP0603	TDK	C1608X5R0J106K080AB
8	3	D1,D4,D7	GRN	LED0603	Würth electronics	150 060 GS7 500 0
9	1	D2	RED	LED0603	Würth electronics	150 060 RS7 500 0
10	5	FB1,FB2,FB3,FB4,FB5	2A/0.05DCR	RES0603	Murata	BLM18EG221SN1D
11	1	J1	SKT_P-WR_2R0mm_4A_THRU_RA	th_conn_pwrjack_dc-210_rt	Cui Stack	PJ-002AH
12	18	J4,J5,J6,J7,J8,J9,J10,J11,J12,J13,J14,J15,J20,J21,J28,J29,J30,J31	HDR_1x3	TH_CONN_1X3P	FCI	68000-103HLF
13	1	J16	HEADER 5X2	th_conn_2x5p_BOX	FCI	67997-210HLF
14	2	J18,J23	MII_RA	TH_CON-N_TE-5173278_40P	TE	5173278-2-ND
15	2	J19,J24	FEMALE MII CONN	TH_CONN_MII-749069-4	TE	749069-4-ND
16	4	J22,J25,J26,J32	CONN_2P	th_conn_1x2p	FCI	68000-102HLF
17	1	J27	HEADER 8	TH_CONN_1X8P	FCI	68000-108HLF
18	1	Q1	NDS355AN_NMOS	soT23-NDS	Fairchild	NDS355AN
19	17	R1,R15,R29,R136,R137,R138,R140,R145,R146,R147,R149, FB6,FB7, R72,R73,R85,R86	0E	RES0603	Panasonic	ERJ-3GEY0R00V
20	4	R2,R8,R74,R84	1K	RES0603	Panasonic	ERJ-3GEYJ102V
21	1	R3	3.30K	RES0603	Yageo America	9C06031A3301FKHFT
22	1	R4	470E	RES0603	BOURNS	CR0603-FX-4700ELF
23	1	R4A	33E	RES0603	BOURNS	CR0603-FX-33R0ELF
24	1	R5	4.75K	RES0603	Panasonic	ERJ-3EKF4751V

TABLE C-1: EVB-LAN9355 EVALUATION BOARD BILL OF MATERIALS (CONTINUED)

Item	Qty	Reference Designator(s)	Part	PCB Footprint	Manufacturer	Manufacturer Part Number
25	26	R6,R69,R70,R71,R81,R82,R83,R76,R79,R80,R99,R100,R143,R152,R104,R105,R106,R107,R108,R109,R110,R111,R112,R113,R114,R115	10.0K	RES0603	Panasonic	ERJ-3EKF1002V
26	1	R7	100E	RES0603	Panasonic	ERJ-3EKF1000V
27	1	R9	2.2K	RES0603	Panasonic	ERJ-3GEYJ222V
28	1	R10	12.1K	RES0603	Rohm	MCR01MZPF1202
29	8	R11,R12,R13,R14,R25,R26,R27,R28	49.9E	RES0603	Yageo America	9C06031A49R9FKHFT
30	8	R17,R19,R21,R23,R31,R33,R35,R37	0E	RES0402	Panasonic	ERJ-2GE0R00X
31	2	R24,R38	0E	RES1210	Vishay	CRCW12100000Z0EA
32	4	R61,R62,R102,R103	330E	RES0603	Panasonic	ERJ-3GEYJ331V
33	2	R67,R68	2K	RES0603	Panasonic	ERJ-3GEYJ202V
34	20	R116,R117,R118,R119,R120,R121,R122,R123,R124,R125,R126,R127,R128,R129,R130,R131,R132,R133,R134,R135	33E	RES0603	Bourns Inc.	CR0603-JW-330ELF
35	2	R141,R150	1.5K	RES0603	Panasonic	ERJ-3GEYJ152V
36	1	SW1	SW-SPDT-SLIDE	sw_ck_1101m2s3cq2	C&K	1101M2S3CQE2
37	1	SW2	sw_pb_2P	sw_pb_2P	Panasonic	EVQ-PJU04K
38	13	SW5,SW6,SW7,SW8,SW9,SW10,SW11,SW12,SW13,SW14,SW15,SW16,SW17	JS102011CQN	TH_SW_SPST_3P_10x2p5	Würth electronics	450301014042
39	1	TP1	RED	TH_TP_60D40	Keystone	5000
40	1	TP2	ORANGE	TH_TP_60D40	Keystone	5003
41	2	TP9,TP10	BLACK	TH_TP_60D40	Keystone	5001
42	2	T1,T2	Pulse - J0011D01BNL	th_conn_pulse_rj45_j0026	Pulse Electronics	553-1483-ND
43	1	U1	3_Amp	TH_DC-DC_VERT_5PIN_P67	Murata	OKR-T/3-W12-C
44	1	U2	TPS3125	SOT23_5	TI	TPS3125L30DBVR
45	1	U3	74LVC1G14	SOT23_5	TI	SN74LVC1G14DCKR
46	1	U5	Round Base	IC_DIP8_300	Assmann	AR08-HZL-TT-R
47	1	U5	24FC512	IC_DIP8_300	Microchip	24FC512-I/P
48	1	U6	LAN9355_QFN88	IC_QFN88	Microchip	LAN9355
49	1	Y1	25.000MHz	XTAL_HCM49	Cardinal Components Inc.	CSM1Z-A5B2C5-40-25.0D18-F

NOTES:



MICROCHIP

Worldwide Sales and Service

AMERICAS

Corporate Office

2355 West Chandler Blvd.
Chandler, AZ 85224-6199
Tel: 480-792-7200
Fax: 480-792-7277
Technical Support:
<http://www.microchip.com/support>

Web Address:

www.microchip.com

Atlanta

Duluth, GA
Tel: 678-957-9614
Fax: 678-957-1455

Austin, TX

Tel: 512-257-3370

Boston

Westborough, MA
Tel: 774-760-0087
Fax: 774-760-0088

Chicago

Itasca, IL
Tel: 630-285-0071
Fax: 630-285-0075

Cleveland

Independence, OH
Tel: 216-447-0464
Fax: 216-447-0643

Dallas

Addison, TX
Tel: 972-818-7423
Fax: 972-818-2924

Detroit

Novi, MI
Tel: 248-848-4000

Houston, TX

Tel: 281-894-5983

Indianapolis

Noblesville, IN
Tel: 317-773-8323
Fax: 317-773-5453

Los Angeles

Mission Viejo, CA
Tel: 949-462-9523
Fax: 949-462-9608

New York, NY

Tel: 631-435-6000

San Jose, CA

Tel: 408-735-9110

Canada - Toronto

Tel: 905-673-0699
Fax: 905-673-6509

ASIA/PACIFIC

Asia Pacific Office

Suites 3707-14, 37th Floor
Tower 6, The Gateway
Harbour City, Kowloon

Hong Kong

Tel: 852-2943-5100
Fax: 852-2401-3431

Australia - Sydney

Tel: 61-2-9868-6733
Fax: 61-2-9868-6755

China - Beijing

Tel: 86-10-8569-7000
Fax: 86-10-8528-2104

China - Chengdu

Tel: 86-28-8665-5511
Fax: 86-28-8665-7889

China - Chongqing

Tel: 86-23-8980-9588
Fax: 86-23-8980-9500

China - Dongguan

Tel: 86-769-8702-9880

China - Hangzhou

Tel: 86-571-8792-8115
Fax: 86-571-8792-8116

China - Hong Kong SAR

Tel: 852-2943-5100
Fax: 852-2401-3431

China - Nanjing

Tel: 86-25-8473-2460
Fax: 86-25-8473-2470

China - Qingdao

Tel: 86-532-8502-7355
Fax: 86-532-8502-7205

China - Shanghai

Tel: 86-21-5407-5533
Fax: 86-21-5407-5066

China - Shenyang

Tel: 86-24-2334-2829
Fax: 86-24-2334-2393

China - Shenzhen

Tel: 86-755-8864-2200
Fax: 86-755-8203-1760

China - Wuhan

Tel: 86-27-5980-5300
Fax: 86-27-5980-5118

China - Xian

Tel: 86-29-8833-7252
Fax: 86-29-8833-7256

ASIA/PACIFIC

China - Xiamen

Tel: 86-592-2388138
Fax: 86-592-2388130

China - Zhuhai

Tel: 86-756-3210040
Fax: 86-756-3210049

India - Bangalore

Tel: 91-80-3090-4444
Fax: 91-80-3090-4123

India - New Delhi

Tel: 91-11-4160-8631
Fax: 91-11-4160-8632

India - Pune

Tel: 91-20-3019-1500

Japan - Osaka

Tel: 81-6-6152-7160
Fax: 81-6-6152-9310

Japan - Tokyo

Tel: 81-3-6880-3770
Fax: 81-3-6880-3771

Korea - Daegu

Tel: 82-53-744-4301
Fax: 82-53-744-4302

Korea - Seoul

Tel: 82-2-554-7200
Fax: 82-2-558-5932 or
82-2-558-5934

Malaysia - Kuala Lumpur

Tel: 60-3-6201-9857
Fax: 60-3-6201-9859

Malaysia - Penang

Tel: 60-4-227-8870
Fax: 60-4-227-4068

Philippines - Manila

Tel: 63-2-634-9065
Fax: 63-2-634-9069

Singapore

Tel: 65-6334-8870
Fax: 65-6334-8850

Taiwan - Hsin Chu

Tel: 886-3-5778-366
Fax: 886-3-5770-955

Taiwan - Kaohsiung

Tel: 886-7-213-7828

Taiwan - Taipei

Tel: 886-2-2508-8600
Fax: 886-2-2508-0102

Thailand - Bangkok

Tel: 66-2-694-1351
Fax: 66-2-694-1350

EUROPE

Austria - Wels

Tel: 43-7242-2244-39
Fax: 43-7242-2244-393

Denmark - Copenhagen

Tel: 45-4450-2828
Fax: 45-4485-2829

France - Paris

Tel: 33-1-69-53-63-20
Fax: 33-1-69-30-90-79

Germany - Dusseldorf

Tel: 49-2129-3766400

Germany - Munich

Tel: 49-89-627-144-0
Fax: 49-89-627-144-44

Germany - Pforzheim

Tel: 49-7231-424750

Italy - Milan

Tel: 39-0331-742611
Fax: 39-0331-466781

Italy - Venice

Tel: 39-049-7625286

Netherlands - Drunen

Tel: 31-416-690399
Fax: 31-416-690340

Poland - Warsaw

Tel: 48-22-3325737

Spain - Madrid

Tel: 34-91-708-08-90
Fax: 34-91-708-08-91

Sweden - Stockholm

Tel: 46-8-5090-4654

UK - Wokingham

Tel: 44-118-921-5800
Fax: 44-118-921-5820

01/27/15



Стандарт Электрон Связь

Мы молодая и активно развивающаяся компания в области поставок электронных компонентов. Мы поставляем электронные компоненты отечественного и импортного производства напрямую от производителей и с крупнейших складов мира.

Благодаря сотрудничеству с мировыми поставщиками мы осуществляем комплексные и плановые поставки широчайшего спектра электронных компонентов.

Собственная эффективная логистика и склад в обеспечивает надежную поставку продукции в точно указанные сроки по всей России.

Мы осуществляем техническую поддержку нашим клиентам и предпродажную проверку качества продукции. На все поставляемые продукты мы предоставляем гарантию .

Осуществляем поставки продукции под контролем ВП МО РФ на предприятия военно-промышленного комплекса России , а также работаем в рамках 275 ФЗ с открытием отдельных счетов в уполномоченном банке. Система менеджмента качества компании соответствует требованиям ГОСТ ISO 9001.

Минимальные сроки поставки, гибкие цены, неограниченный ассортимент и индивидуальный подход к клиентам являются основой для выстраивания долгосрочного и эффективного сотрудничества с предприятиями радиоэлектронной промышленности, предприятиями ВПК и научно-исследовательскими институтами России.

С нами вы становитесь еще успешнее!

Наши контакты:

Телефон: +7 812 627 14 35

Электронная почта: sales@st-electron.ru

Адрес: 198099, Санкт-Петербург,
Промышленная ул, дом № 19, литера Н,
помещение 100-Н Офис 331