

DESCRIPTION

Demonstration circuit 637 features the LT[®]3465 and LT[®]3465A constant-current white LED drivers in small SOT23 ThinSOT packages. The demo board is designed to demonstrate high efficiency and small size performance of the LT3465 and LT3465A, made possible by a 200mV feedback voltage, 1.2MHz (2.4MHz for LT3465A) switching frequency, and a special internal compensation network allowing 0603 input/output capacitors (the output capacitor at 0.22uF). The DC637 is specifically designed for white LED backlight applications using 2~4 LEDs, making

the LT3465 an ideal solution for battery powered portable applications such as cellular phone, digital camera, MP3 player, GPS receiver, and handheld computer (PDAs). LT3465 offers numerous LED-dimming circuit options, see the datasheet for more detailed information on LED brightness control.

Design files for this circuit board are available. Call the LTC factory.

LT is a registered trademark of Linear Technology Corporation

Table 1. Performance Summary (T_A = 25°C)

PARAMETER FOR LED DRIVER	CONDITION	VALUE
Output Voltage	V _{IN} = 2.7V ~ 5V	~13V
Typical Output Ripple	V _{IN} = 3.6V, I _{LED} = 15mA	~30mV
Typical Efficiency	V _{IN} = 3.6V, I _{LED} = 15mA	80%

QUICK START PROCEDURE

DC637 is easily set up for evaluating the LT3465 and LT3465A low noise constant-current step-up LED driver circuit. Follow the test procedure outlined below and see Figure1.

1. There are two LED driver circuits on DC637. The two circuits are named “Efficiency” and “Size”. Placing the JP2 jumper to “Efficiency” enables the more efficient LT3465 circuit and placing JP2 jumper to “Size” enables the smaller LT3465A circuit. Place the JP2 jumper on “Efficiency” to test the LT3465 circuit. If you want to test “Size” circuit, go to step 6.
2. The demo circuit can be powered from a 3V Lithium battery installed on the demo board (BT1) or other input source (bench top power supply) by selecting input source jumper (JP1). For battery (BT1) input operation, place the jumper (JP1) to “BATTERY” position and go to step 4.
3. For bench supply input, place the jumper (JP1) in the “Vin” position and connect a

3.3V, 500mA bench supply to the Vin and Gnd terminals.

4. Turn on the input power supply or connect the single cell Li-Ion battery. Turn on the LT3465 LED driver circuit by pressing SW1. Observe all four white LEDs light up with uniform brightness. The output voltage should measure about 13V across the “Vout Test” terminal to “Gnd” terminal.
5. The led brightness is controlled by the DC voltage at the CTRL terminal. The typical DC voltage range recommended for dimming is 200mV~ 1.5V. See the LT3465 data sheet for more information on CTRL dimming control.
6. Place the jumper on “Size” to test the LT3465A circuit.
7. The demo board can be powered from a 3V Lithium battery installed on the demo board (BT1) or other input source (bench top power supply) by selecting input source jumper

QUICK START GUIDE FOR DEMONSTRATION CIRCUIT 637

SINGLE CELL WHITE LED (4) DRIVER

- (JP1). For battery (BT1) input operation, place the jumper (JP1) to “BATTERY” position and go to step 9.
- For bench supply input, place the jumper (JP1) in the “Vin” position and connect a 3.3V, 500mA bench supply to the Vin and Gnd terminals.
 - Turn on the input power supply or connect the single cell Li-Ion battery. Turn on the LT3465A LED driver circuit by pressing SW2. Observe all four white LEDs light up with uniform brightness. The output voltage should measure about 13V across the “Vout Test” terminal to “Gnd” terminal.
 - The LED brightness is controlled by a PWM signal at the CTRL terminal. The typical frequency range recommended for PWM dimming is 1kHz~10kHz with a signal magnitude of 2V. See the LT3465A data sheet for more information on CTRL dimming control.

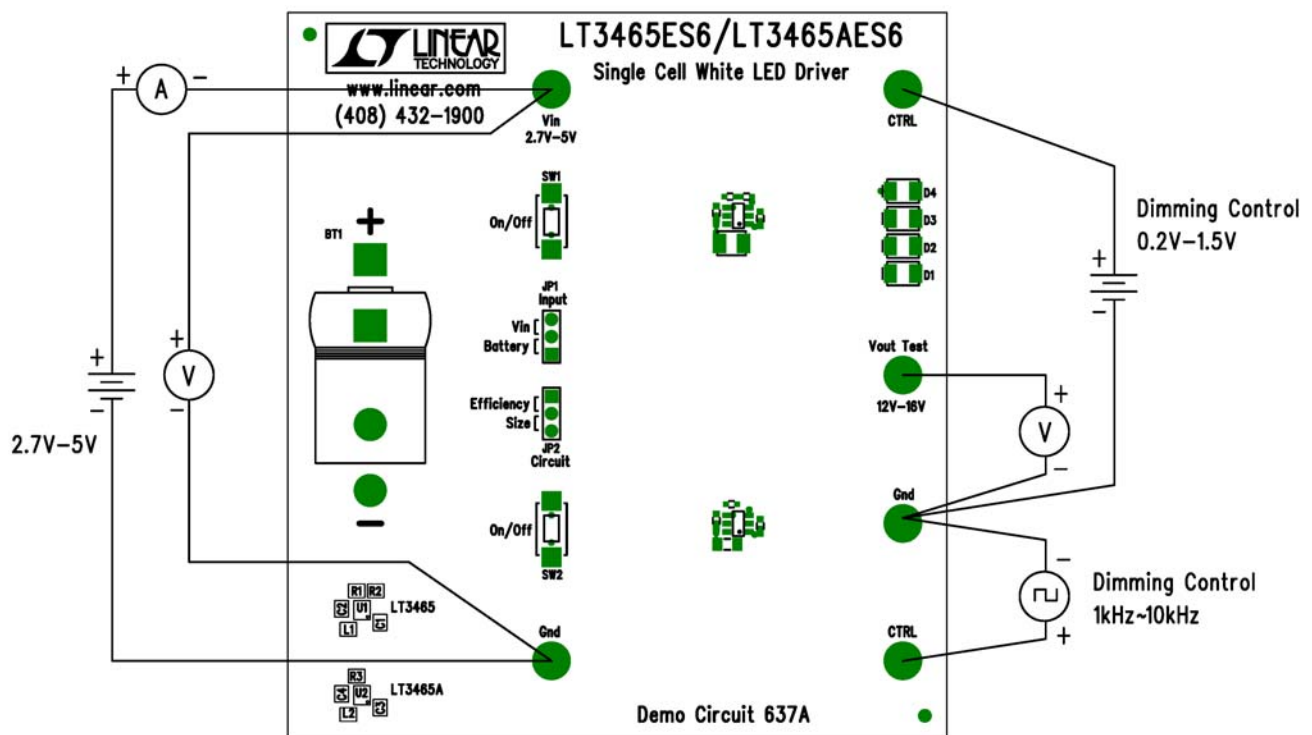

Figure 1. Proper Measurement Equipment Setup

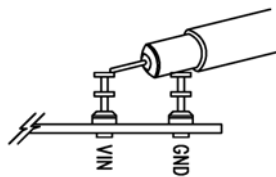
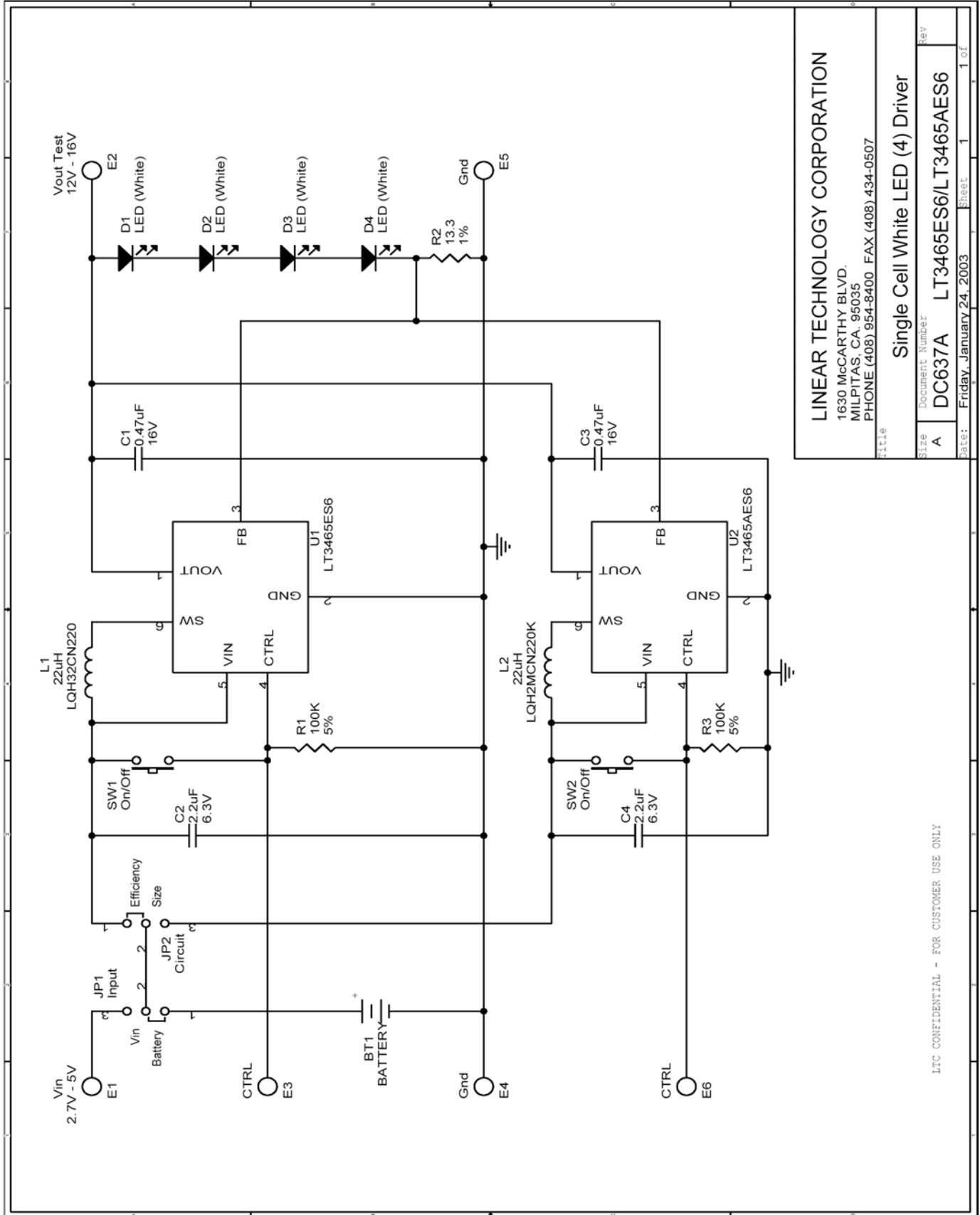

Figure 2. Scope Probe Placement for Measuring Input or Output Ripple

QUICK START GUIDE FOR DEMONSTRATION CIRCUIT 637

SINGLE CELL WHITE LED (4) DRIVER



LINEAR TECHNOLOGY CORPORATION
 1630 McCARTHY BLVD.
 MILPITAS, CA, 95035
 PHONE (408) 954-8400 FAX (408) 434-0507

Title		Single Cell White LED (4) Driver	
Size	Document Number	Rev	
A	DC637A	LT3465ES6/LT3465AES6	
Date:	Friday, January 24, 2003	Sheet	1 of 1

LTC CONFIDENTIAL - FOR CUSTOMER USE ONLY

QUICK START GUIDE FOR DEMONSTRATION CIRCUIT 637

SINGLE CELL WHITE LED (4) DRIVER



Стандарт Электрон Связь

Мы молодая и активно развивающаяся компания в области поставок электронных компонентов. Мы поставляем электронные компоненты отечественного и импортного производства напрямую от производителей и с крупнейших складов мира.

Благодаря сотрудничеству с мировыми поставщиками мы осуществляем комплексные и плановые поставки широчайшего спектра электронных компонентов.

Собственная эффективная логистика и склад в обеспечивает надежную поставку продукции в точно указанные сроки по всей России.

Мы осуществляем техническую поддержку нашим клиентам и предпродажную проверку качества продукции. На все поставляемые продукты мы предоставляем гарантию .

Осуществляем поставки продукции под контролем ВП МО РФ на предприятия военно-промышленного комплекса России , а также работаем в рамках 275 ФЗ с открытием отдельных счетов в уполномоченном банке. Система менеджмента качества компании соответствует требованиям ГОСТ ISO 9001.

Минимальные сроки поставки, гибкие цены, неограниченный ассортимент и индивидуальный подход к клиентам являются основой для выстраивания долгосрочного и эффективного сотрудничества с предприятиями радиоэлектронной промышленности, предприятиями ВПК и научно-исследовательскими институтами России.

С нами вы становитесь еще успешнее!

Наши контакты:

Телефон: +7 812 627 14 35

Электронная почта: sales@st-electron.ru

Адрес: 198099, Санкт-Петербург,
Промышленная ул, дом № 19, литера Н,
помещение 100-Н Офис 331