

Intel® Quark™ Microcontroller Developer Kit D2000

User Guide

April 2016



You may not use or facilitate the use of this document in connection with any infringement or other legal analysis concerning Intel products described herein. You agree to grant Intel a non-exclusive, royalty-free license to any patent claim thereafter drafted which includes subject matter disclosed herein

No license (express or implied, by estoppel or otherwise) to any intellectual property rights is granted by this document.

All information provided here is subject to change without notice. Contact your Intel representative to obtain the latest Intel product specifications and roadmaps.

The products described may contain design defects or errors known as errata which may cause the product to deviate from published specifications. Current characterized errata are available on request.

Copies of documents which have an order number and are referenced in this document may be obtained by calling 1-800-548-4725 or by visiting: <http://www.intel.com/design/literature.htm>

Intel technologies' features and benefits depend on system configuration and may require enabled hardware, software or service activation. Learn more at <http://www.intel.com/> or from the OEM or retailer.

No computer system can be absolutely secure.

Intel, Intel Quark, and the Intel logo are trademarks of Intel Corporation in the U.S. and/or other countries.

*Other names and brands may be claimed as the property of others.

Copyright © 2016, Intel Corporation. All rights reserved.

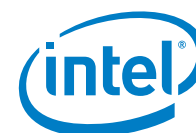

Contents

1.0	Introduction.....	5
1.1	Terminology	5
1.2	Toolchain	6
1.3	Reference Documents	6
1.4	Block Diagram	7
2.0	Hardware.....	8
2.1	Board Components.....	8
2.2	Board Photo.....	9
2.3	Board Jumpers	9
2.4	Board Pinouts.....	10
3.0	Software and Tools.....	12
3.1	Intel® System Studio for Microcontrollers.....	12
3.1.1	Installation	13
3.1.2	Getting Started Guide.....	13
3.1.3	User and Reference Guide.....	13
3.2	BSP Release Note.....	14
3.3	Application Notes.....	14

Figures

Figure 1.	Intel® Quark™ Microcontroller Developer Kit D2000 Block Diagram	7
Figure 2.	Intel® Quark™ Microcontroller Developer Kit D2000 Fab D Board Photo	9

Tables

Table 1.	Terminology	5
Table 2.	Reference Documents for This Installation	6
Table 3.	Additional Reference Documents.....	6
Table 4.	3rd Party Board Components: Integrated Circuits	8
Table 5.	Pin Mapping.....	10

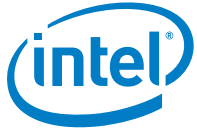

Revision History

Date	Revision	Description
April 2016	002	Booster Pack Pin Mapping added to Table 5.
February 2016	001	Initial release



1.0 Introduction

This document describes Intel® Quark™ Microcontroller Developer Kit D2000 including the board, the hardware contained, and the toolchain required for software development and debugging. The platform consists of a small form-factor board and includes flash storage, a 6-axis compass and accelerometer and an Arduino Uno compatible shields' interface. A USB connection enables programming and debugging (JTAG).

1.1 Terminology

Table 1. Terminology

Term	Description
ADC	Analog-to-Digital conversion
BSP	Board Support Package – Refers to OS + Device Drivers
CRB	Customer Reference Board
ELF	Executable Linkable Format
GDB	GNU Debugger
GPIO	General-Purpose Input / Output
IDE	Integrated Development Environment
I ² C	Inter-Integrated Circuit
JTAG	Joint Test Action Group
MCU	Microcontroller unit
OpenOCD	Open On-Chip Debugger; interfaces with a JTAG port
QFN	Quad Flat No-leads
SPI	Serial Peripheral Interface
UART	Universal Asynchronous Receiver / Transmitter



1.2 Toolchain

The toolchain for programming the D2000 is called *Intel® System Studio for Microcontrollers*.

Intel® System Studio for Microcontrollers is available at the following link:

<https://software.intel.com/en-us/intel-system-studio-microcontrollers>

For more details on the toolchain, see [3.0 Software and Tools](#).

1.3 Reference Documents

This document provides an overview of the setup process. For a successful setup, ensure you have the documents listed in Table 2 available. These documents provide specific information and step-by-step instructions.

Table 2. Reference Documents for This Installation

Document	Document # / Location
Getting Started with Intel® System Studio for Microcontrollers	Distributed in toolchain
Intel® System Studio 2016 for Microcontrollers User and Reference Guide	Distributed in toolchain

Table 3. Additional Reference Documents

Document	Document # / Location
<i>Intel® Quark™ Microcontroller D2000 Datasheet</i>	www.intel.com/quark/mcu/d2000
<i>Intel® System Studio for Microcontrollers 2016 Release Notes</i>	Included with the S/W Distribution
Intel® Quark™ Microcontroller Software Interface BSP: Release Notes	www.intel.com/quark/mcu/d2000
Intel® Quark™ Microcontroller D2000 Customer Reference Board (CRB) Hardware Manual	www.intel.com/quark/mcu/d2000

Contact your Intel representative for access to these documents or click on the following link for more information:

<http://www.intel.com/content/www/us/en/embedded/products/quark/mcu/d2000/overview.html>

1.4 Block Diagram

Figure 1. Intel® Quark™ Microcontroller Developer Kit D2000 Block Diagram

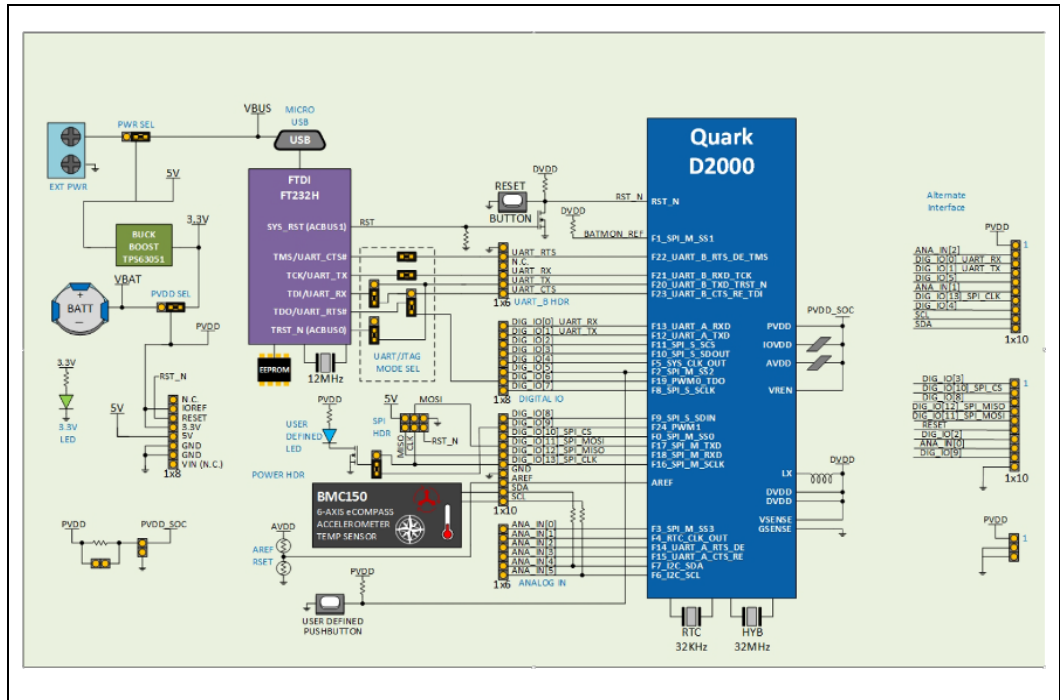



2.0 Hardware

The Intel® Quark™ microcontroller D2000 package is shipped as a 40-pin QFN component.

2.1 Board Components

Intel® Quark™ Microcontroller Developer Kit D2000 contains the following items:

Main expansion options:

- “Arduino Uno” compatible SIL sockets (3.3V IO only)
- Booster pack compatible SIL headers (3.3V IO only)

On-board components:

- 6-axis Accelerometer / Magnetometer with temperature sensor
- UART/JTAG to USB convert for USB debug port

Other connectors include:

- 1x USB 2.0 Device Port – micro Type B
- On-board coin cell battery holder (type CR2032)
- 5V input a screw terminal/header (external power or Li-ion)

Power sources for this platform:

- External (2.5V - 5V) DC input
- USB power (5V) – via debug port
- Coin cell battery (type CR2032 not supplied)

Table 4. 3rd Party Board Components: Integrated Circuits¹

Component	Manufacturer	Part Number
6-AXIS E Compass and Accelerometer	Bosch Sensortec GMBH	BMC150
SERIAL_EEPROM	Microchip	93LC56BT-I/OT
USB <--> UART & JTAG	FTDI	FT232HL
SPST Switch	E-Switch	TL1015AF160QG
Connector USB - micro B	TE Connectivity	1981568-1
THM Holder for 20mm Coin Cell Batteries	Keystone Electronics CORP.	3003
Single Inductor Buck-Boost With 1-A Switches and Adjustable Soft Start	Texas Instruments	TPS63051RMWT

1. Other names and brands may be claimed as the property of others.

2.2 Board Photo

Figure 2. Intel® Quark™ Microcontroller Developer Kit D2000 Fab D Board Photo



2.3 Board Jumpers

1. FTDI UART/JTAG*

J12 and J13 Jumpers are installed for both JTAG and UART by default. To isolate the Intel® Quark™ microcontroller D2000 from the FTDI FT232HL, remove all the sleeves from Jumpers J7, J9, J10, J12, and J13.

- J7 [2-3] JTAG (Default) [1-2] UART
- J9 [2-3] JTAG (Default) [1-2] UART
- J10 [2-3] JTAG (Default) [1-2] UART

2. Power

- Place J19 Jumper at [1-2] (Default) when the USB Port is in use.
- Place J25 Jumper at [1-2] (Default) when the USB Port is in use.
- J23 Jumper [1-2] (Default)

***Note:** Debug and firmware loading is currently only supported via JTAG. By using UART_B, your application disables the JTAG interface.



2.4 Board Pinouts

Table 5. Pin Mapping

Pin Label	CRB Pin Usage	Arduino Shield Interface	User Mode0	User Mode1	User Mode2	Booster Pack Pin(s)
J2_1	GND					J13_10, J21_2, J21_3
J2_2	USB port / Hdr		JTAG_TMS	GPIO_22	UART_B_RTS	
J2_3	N/C					
J2_4	USB port / Hdr		JTAG_TCK	GPIO_21	UART_B_RXD	
J2_5	USB port / Hdr		JTAG_TRS_T_N	GPIO_20	UART_B_TXD	
J2_6	USB port / Hdr		JTAG_TDI	GPIO_23	UART_B_CTS	
J3_1	DIO_8	DIO_8	GPIO_9	ADC/COMP_9	SPI_S_SDIN	J13_3
J3_2	DIO_09	DIO_09	GPIO_24	GPIO_24	PWM1	J13_9
J3_3	SPI_M_SSO	SPI_SS_DIO_10	GPIO_0	ADC/COMP_0	SPI_M_SSO	J13_2
J3_4	M_MOSI/DIO_11	MOSI/DIO_11	GPIO_17	ADC/COMP_17	SPI_M_DOUT	J13_5
J3_5	M_MISO/DIO_12	MISO/DIO_12	GPIO_18	ADC/COMP_18	SPI_M_DIN	J13_4
J3_6	M_SCK/DIO_13	SCK/DIO_13	GPIO_16	ADC/COMP_16	M_SCK/DIO_13	J8_7
J3_7	GND					
J3_8	AREF					
J3_9	SDA/AIN_04	SDA/AIN_04/DIO_18	GPIO_7	ADC/COMP_7	I2C_SDA	J8_10
J3_10	SCL/AIN_05	SCL/AIN_05/DIO_19	GPIO_6	ADC/COMP_6	I2C_SCL	J8_9
J4_1	UART_RXD/DIO_00	UART_RXD/DIO_00	GPIO_13	ADC/COMP_13	UART_A_RXD	J8_3



Pin Label	CRB Pin Usage	Arduino Shield Interface	User Mode0	User Mode1	User Mode2	Booster Pack Pin(s)
J4_2	UART_TXD/DIO_01	UART_TXD/DIO_01	GPIO_12	ADC/COMP 12	UART_A_TXD	J8_4
J4_3	DIO_02	DIO_02	GPIO_11	ADC/COMP 11	SPI_S_SCS	J13_7
J4_4	DIO_03	DIO_03	GPIO_10	ADC/COMP 10	SPI_S_SDOUT	J13_1
J4_5	DIO_04	DIO_04	GPIO_5	ADC/COMP 5	SYS_CLK_OUT	J8_8
J4_6	DIO_05	DIO_05	GPIO_2	ADC/COMP 2	SPI_M_SS2	J8_5
J4_7	USB port/DIO_06	DIO_06	JTAG_TDO	GPIO_19	PWM0	
J4_8	DIO_07	DIO_07	GPIO_8	ADC/COMP 8	SPI_S_SCLK	
J22_1	NC					
J22_2	IOREF					
J22_3	RESET_N	RESET_N	RST_N			J13_6
J22_4	3.3V					J8_1, J21_1
J22_5	5V					
J22_6	GND					
J22_7	GND					
J22_8	NC					
J23_1	AIN_00	AIN_00	GPIO_3	ADC/COMP 3	SPI_M_SS3	J13_8
J23_2	AIN_01	AIN_01	GPIO_4	ADC/COMP 4	RTC_CLK_OUT	J8_6
J23_3	AIN_02	AIN_02	GPIO_14	ADC/COMP 14	UART_A_RTS	J8_2
J23_4	AIN_03	AIN_03	GPIO_15	ADC/COMP 15	UART_A_CTS	
J23_5	NC					
J23_6	NC					



3.0 *Software and Tools*

3.1 **Intel® System Studio for Microcontrollers**

Intel® System Studio for Microcontrollers is an integrated tool set for developing, optimizing, and debugging systems and applications for the Intel® Quark™ microcontroller D2000.

The suite consists of the following components:

- GCC* Version 5.2.1
 - Linker
 - Assembler
 - C Run-time Libraries
- Intel-enhanced GDB* 7.9
- Intel® Integrated Performance Primitives for Microcontrollers 1.0
- Floating Point Emulation library
- Sample Applications
- Board Support Package (BSP) for the Intel® Quark™ Microcontroller Software Interface (Intel® QMSI)
- OpenOCD* 0.8.0
- TinyCrypt* 0.1.0 (Internet connection required during installation)
- Intel® Quark™ Microcontroller Software Interface 1.0
- Eclipse* Luna 4.4 including Intel® System Studio for Microcontrollers integration
- Python™ 2.7.10
- WinUSB* driver for Intel® Quark™ Microcontrollers

The suite is supported on the following OS hosts:

- Linux (64bit: Versions Ubuntu* 14.04 LTS, Fedora 21)
- Windows* (64bit: Versions 7, 8.1, 10)



3.1.1 Installation

Installing the IDE begins by following the *Intel® System Studio for Microcontrollers 2016 Release Notes*. The release notes contain all system requirements and all prerequisites.

Follow the instructions in:

<i>Intel® System Studio for Microcontrollers 2016 Release Notes</i>	Distributed with toolchain
---	----------------------------

Note: The *Intel® System Studio for Microcontrollers 2016 Release Notes* is a separate document and should be followed at this point.

3.1.2 Getting Started Guide

On completing the installation, locate the documentation files in the `docs` folder under the installation path. The `get_started.htm` file provides an easy guide to the set up and use of this tool suite with the *Intel® Quark™ D2000 microcontroller and Eclipse* IDE*.

Follow the instructions in:

<i>Getting Started with Intel® System Studio for Microcontrollers</i>	Distributed in toolchain
---	--------------------------

Note: The *Getting Started with Intel® System Studio for Microcontrollers* is a separate document and should be followed at this point.

3.1.3 User and Reference Guide

The *Intel® System Studio 2016 for Microcontrollers User and Reference Guide* located in `issm_user_ref_guide.htm` contains more detailed information about this tool suite, including:

- Developing in the command line
- Using the compiler
- Using Intel® Integrated Performance Primitives for Microcontrollers (Intel® IPP for Microcontrollers)
- Using the Floating Point Library
- Using the TiinyCrypt library

Follow the detailed, step-by-step instructions in:

<i>Intel® System Studio 2016 for Microcontrollers User and Reference Guide</i>	Distributed in toolchain
--	--------------------------

Note: The *Intel® System Studio 2016 for Microcontrollers User and Reference Guide* is a separate document and should be followed at this point.



3.2 BSP Release Note

The *Intel® Quark™ Microcontroller Software Interface BSP Release Notes* contain release-specific information, including:

- Notes about the Board Support Package
- Installation instructions
- Details on provided utilities and applications
- Known issues and workarounds.
- Supported features of the release.

3.3 Application Notes

As of the writing of this document, no application notes have been created. As this document gets updated, they will be provided.

Mouser Electronics

Authorized Distributor

Click to View Pricing, Inventory, Delivery & Lifecycle Information:

Intel:

[MTFLD.CRBD.AL](#)



Стандарт Электрон Связь

Мы молодая и активно развивающаяся компания в области поставок электронных компонентов. Мы поставляем электронные компоненты отечественного и импортного производства напрямую от производителей и с крупнейших складов мира.

Благодаря сотрудничеству с мировыми поставщиками мы осуществляем комплексные и плановые поставки широчайшего спектра электронных компонентов.

Собственная эффективная логистика и склад в обеспечивает надежную поставку продукции в точно указанные сроки по всей России.

Мы осуществляем техническую поддержку нашим клиентам и предпродажную проверку качества продукции. На все поставляемые продукты мы предоставляем гарантию .

Осуществляем поставки продукции под контролем ВП МО РФ на предприятия военно-промышленного комплекса России , а также работаем в рамках 275 ФЗ с открытием отдельных счетов в уполномоченном банке. Система менеджмента качества компании соответствует требованиям ГОСТ ISO 9001.

Минимальные сроки поставки, гибкие цены, неограниченный ассортимент и индивидуальный подход к клиентам являются основой для выстраивания долгосрочного и эффективного сотрудничества с предприятиями радиоэлектронной промышленности, предприятиями ВПК и научно-исследовательскими институтами России.

С нами вы становитесь еще успешнее!

Наши контакты:

Телефон: +7 812 627 14 35

Электронная почта: sales@st-electron.ru

Адрес: 198099, Санкт-Петербург,
Промышленная ул, дом № 19, литера Н,
помещение 100-Н Офис 331