

---

---

## Universal High-Brightness LED Driver

---

---

### Features

- Switch mode controller for single switch LED drivers
- Enhanced drop-in replacement to the HV9910B
- Open loop peak current controller
- Internal 15 to 450V linear regulator
- Constant frequency or constant off-time operation
- Linear and PWM dimming capability
- Requires few external components for operation
- Over-temperature protection

### Applications

- DC/DC or AC/DC LED driver applications
- RGB back-lighting LED driver
- Back lighting of flat panel displays
- General purpose constant current source
- Signage and decorative LED lighting
- Chargers

### Description

HV9910C is an open-loop, current-mode control, LED driver IC. This IC can be programmed to operate in either a constant frequency or constant off-time mode. It includes a 15 – 450V linear regulator which allows it to work with a wide range of input voltages without the need for an external low voltage supply. HV9910C includes a TTL-compatible, PWM-dimming input that can accept an external control signal with a duty ratio of 0 – 100% and a frequency of up to a few kilohertz. It also includes a 0 – 250mV linear-dimming input which can be used for linear dimming of the LED current. Unlike the HV9910B, the HV9910C is equipped with built-in thermal-shutdown protection.

HV9910C is ideally suited for buck LED drivers. Since the HV9910C operates in open-loop current mode control, the controller achieves good output current regulation without the need for any loop compensation. Also, being an open-loop controller, PWM-dimming response is limited only by the rate of rise of the inductor current, enabling a very fast rise and fall times of the LED current. HV9910C requires only three external components (apart from the power stage) to produce a controlled LED current. This makes HV9910C an ideal solution for low-cost LED drivers.

## TO OUR VALUED CUSTOMERS

It is our intention to provide our valued customers with the best documentation possible to ensure successful use of your Microchip products. To this end, we will continue to improve our publications to better suit your needs. Our publications will be refined and enhanced as new volumes and updates are introduced.

If you have any questions or comments regarding this publication, please contact the Marketing Communications Department via E-mail at [docerrors@microchip.com](mailto:docerrors@microchip.com). We welcome your feedback.

### Most Current Data Sheet

To obtain the most up-to-date version of this data sheet, please register at our Worldwide Web site at:

<http://www.microchip.com>

You can determine the version of a data sheet by examining its literature number found on the bottom outside corner of any page. The last character of the literature number is the version number, (e.g., DS30000000A is version A of document DS30000000).

### Errata

An errata sheet, describing minor operational differences from the data sheet and recommended workarounds, may exist for current devices. As device/documentation issues become known to us, we will publish an errata sheet. The errata will specify the revision of silicon and revision of document to which it applies.

To determine if an errata sheet exists for a particular device, please check with one of the following:

- Microchip's Worldwide Web site; <http://www.microchip.com>
- Your local Microchip sales office (see last page)

When contacting a sales office, please specify which device, revision of silicon and data sheet (include literature number) you are using.

### Customer Notification System

Register on our web site at [www.microchip.com](http://www.microchip.com) to receive the most current information on all of our products.

## Pin Diagram

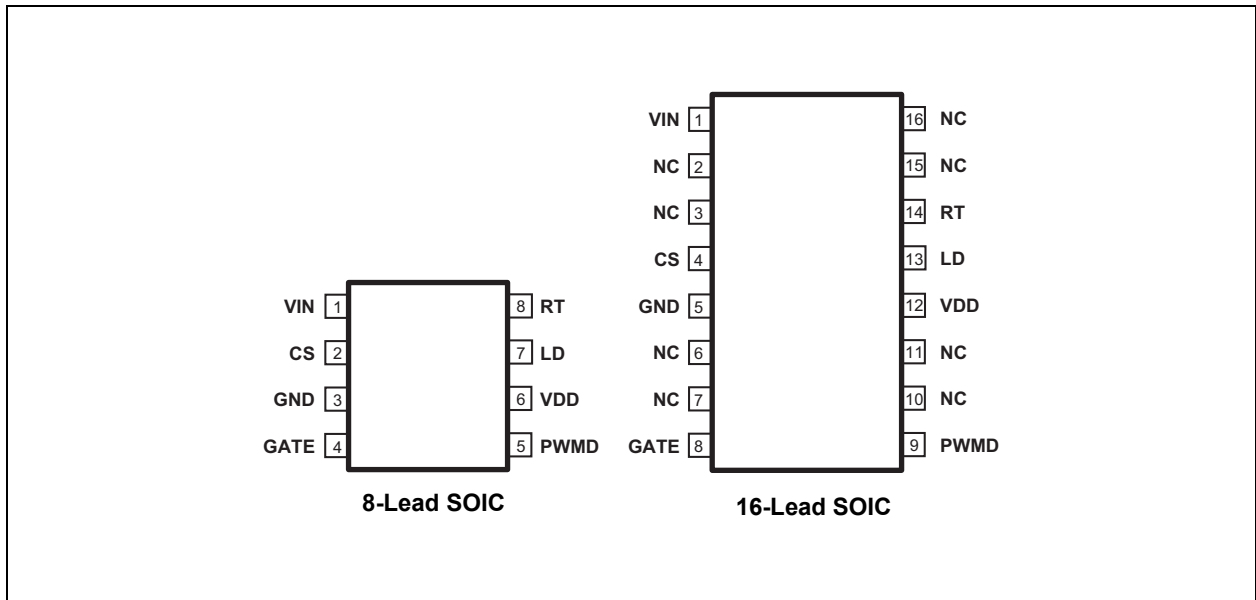

## Typical Application Circuit

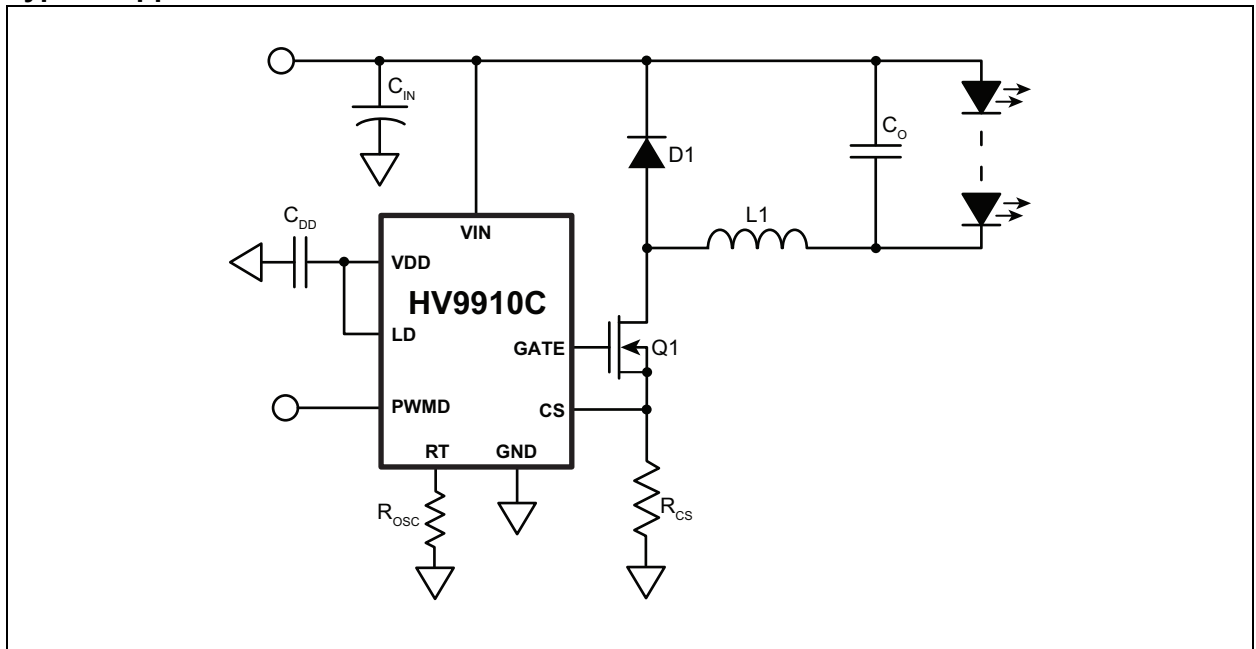

# HV9910C

## 1.0 ELECTRICAL CHARACTERISTICS

### ABSOLUTE MAXIMUM RATINGS

$V_{IN}$ to GND .....	-0.5V to +470V
$V_{DD}$ to GND.....	12V
CS, LD, PWMD, GATE.....	-0.3V to ( $V_{DD} + 0.3V$ )
Junction temperature .....	-40°C to +125°C
Storage temperature .....	-65°C to +150°C
Continuous power dissipation ( $T_A = +25^\circ\text{C}$ )	
8-lead SOIC .....	650 mW
16-lead SOIC .....	1300 mW
8-lead SOIC with heat slug .....	1300 mW

**Note:** Stresses above those listed under “Absolute Maximum Ratings” may cause permanent damage to the device. This is a stress rating only and functional operation of the device at those or any other conditions, above those indicated in the operational listings of this specification, is not implied. Exposure to maximum rating conditions for extended periods may affect device reliability.

### 1.1 ELECTRICAL SPECIFICATIONS

TABLE 1-1: ELECTRICAL CHARACTERISTICS (SHEET 1 OF 2)<sup>1</sup>

Symbol	Parameter	Note	Min	Typ	Max	Units	Conditions
<b>Input</b>							
$V_{INDC}$	Input DC supply voltage range <sup>2</sup>	3	15	-	450	V	DC input voltage
$I_{IN(MAX)}$	Supply current	-	-	0.8	1.5	mA	Pin PWMD to $V_{DD}$ , no capacitance at GATE
$I_{INSD}$	Shut-down mode supply current	-	-	0.5	1.0	mA	Pin PWMD to GND
<b>Internal Regulator</b>							
$V_{DD}$	Internally regulated voltage	-	7.25	7.50	7.75	V	$V_{IN} = 15V$ , $I_{DD(ext)} = 0$ , PWMD = $V_{DD}$ , 500pF at GATE; $R_{OSC} = 249k\Omega$
$\Delta V_{DD, line}$	Line regulation of $V_{DD}$	-	0	-	1.0	V	$V_{IN} = 15 - 450V$ , $I_{DD(ext)} = 0$ , PWMD = $V_{DD}$ , 500pF at GATE; $R_{OSC} = 249k\Omega$
$\Delta V_{DD, load}$	Load regulation of $V_{DD}$	-	0	-	0.1	V	$I_{DD(ext)} = 0 - 1.0mA$ , PWMD = $V_{DD}$ , 500pF at GATE; $R_{OSC} = 249k\Omega$
UVLO	$V_{DD}$ under voltage lockout threshold	3	6.45	6.70	6.95	V	$V_{DD}$ rising
$\Delta UVLO$	$V_{DD}$ under voltage lockout hysteresis	-	-	500	-	mV	$V_{DD}$ falling
$I_{IN(MAX)}$	Maximum regulator current	4	5.0	-	-	mA	$V_{DD} = UVLO - \Delta UVLO$
<b>PWM Dimming</b>							
$V_{EN(lo)}$	PWMD input low voltage	3	-	-	1.0	V	$V_{IN} = 15 - 450V$
$V_{EN(hi)}$	PWMD input high voltage	3	2.4	-	-	V	$V_{IN} = 15 - 450V$
$R_{EN}$	Internal pull-down resistance at PWMD	-	50	100	150	k $\Omega$	$V_{PWMD} = 5.0V$

**TABLE 1-1: ELECTRICAL CHARACTERISTICS (CONTINUED) (SHEET 2 OF 2)<sup>1</sup>**

Symbol	Parameter	Note	Min	Typ	Max	Units	Conditions
<b>Current Sense Comparator</b>							
V <sub>CS</sub>	Current sense pull-in threshold voltage	-	225	250	275	mV	-40°C < T <sub>A</sub> < +125°C
V <sub>OFFSET</sub>	Offset voltage for LD comparator	3	-12	-	+12	mV	
T <sub>BLANK</sub>	Current sense blanking interval	-	150	215	280	ns	0 < T <sub>A</sub> < +85°C, V <sub>LD</sub> = V <sub>DD</sub> , V <sub>CS</sub> = V <sub>CS,TH</sub> + 50mV after T <sub>BLANK</sub>
		-	145	215	315		-40 < T <sub>A</sub> < +125°C, V <sub>LD</sub> = V <sub>DD</sub> , V <sub>CS</sub> = V <sub>CS,TH</sub> + 50mV after T <sub>BLANK</sub>
t <sub>DELAY</sub>	Delay to output	-	-	80	150	ns	V <sub>IN</sub> = 15V, V <sub>LD</sub> = 0.15, V <sub>CS</sub> = 0 to 0.22V after t <sub>BLANK</sub>
<b>Oscillator</b>							
f <sub>OSC</sub>	Oscillator frequency	-	20	25	30	kHz	R <sub>OSC</sub> = 1.00MΩ
		-	80	100	120		R <sub>OSC</sub> = 249kΩ
<b>Gate Driver</b>							
I <sub>SOURCE</sub>	Maximum GATE sourcing current	-	0.165	-	-	A	V <sub>GATE</sub> = 0V
I <sub>SINK</sub>	Maximum GATE sinking current	-	0.165	-	-	A	V <sub>GATE</sub> = V <sub>DD</sub>
t <sub>RISE</sub>	GATE output rise time	4	-	30	50	ns	C <sub>GATE</sub> = 500pF
t <sub>FALL</sub>	GATE output fall time	4	-	30	50	ns	C <sub>GATE</sub> = 500pF
<b>Over-Temperature Protection</b>							
T <sub>SD</sub>	Shut-down temperature	-	128	-	150	°C	
ΔT <sub>SD</sub>	Hysteresis	-	10	-	30	°C	
I <sub>SD</sub>	T <sub>SD</sub> -mode V <sub>IN</sub> current	-	-	-	350	μA	

- 1 Specifications are T<sub>A</sub> = 25°C, V<sub>IN</sub> = 15V unless otherwise noted.
- 2 Also limited by package-power dissipation limit; Whichever is lower.
- 3 Applies over the full operating ambient temperature range of -40°C < T<sub>A</sub> < +125°C.
- 4 For design guidance only.

**TABLE 1-2: THERMAL RESISTANCE**

Package	θ <sub>ja</sub>
8-Lead SOIC	101°C/W
16-Lead SOIC	83°C/W
8-Lead SOIC (with heat slug)	84°C/W

# HV9910C

## 2.0 PIN DESCRIPTION

The descriptions of the pins are listed in [Table 2-1](#).

**TABLE 2-1: PIN DESCRIPTION**

Pin #		Function	Description
8-Lead SOIC	16-Lead SOIC		
1	1	VIN	Input of an 15 - 450V linear regulator.
2	4	CS	Current sense pin used to sense the FET current by means of an external sense resistor. When this pin exceeds the lower of either the internal 250mV or the voltage at the LD pin, the GATE output goes low.
3	5	GND	Ground return for all internal circuitry. Must be electrically connected to the power ground.
4	8	GATE	Output GATE driver for an external N-channel power MOSFET.
5	9	PWMD	TTL-compatible, PWM-dimming input of the IC. When this pin is pulled to GND or left open, the GATE driver is turned off. When the pin is pulled high, the GATE driver operates normally.
6	12	VDD	Power supply pin for all internal circuits. It must be bypassed with a low ESR capacitor to GND ( $\geq 0.1\mu\text{F}$ ).
7	13	LD	Linear-dimming input and sets the current sense threshold as long as the voltage at the pin is less than 250mV (typ).
8	14	RT	Sets the oscillator frequency. When a resistor is connected between RT and GND, the HV9910C operates in constant frequency mode. When the resistor is connected between RT and GATE, the IC operates in constant off-time mode.
-	2, 3, 6, 7, 10, 11, 15, 16	NC	No connection

## 3.0 APPLICATION INFORMATION

HV9910C is optimized to drive buck LED drivers using open-loop, peak-current mode control. This method of control enables fairly accurate LED current control without the need for high side current sensing or the design of any closed loop controllers. The IC uses very few external components and enables both Linear and PWM-dimming of the LED current.

A resistor connected to the RT pin programs the frequency of operation (or the off-time). The oscillator produces pulses at regular intervals. These pulses set the SR flip-flop in the HV9910C which causes the GATE driver to turn on. The same pulses also start the blanking timer, which inhibits the reset input of the SR flip flop and prevents false turn-offs due to the turn-on spike. When the FET turns on, the current through the inductor starts ramping up. This current flows through the external sense resistor,  $R_{CS}$ , and produces a ramp voltage at the CS pin. The comparators are constantly comparing the CS pin voltage to both the voltage at the LD pin and the internal 250mV. Once the blanking timer is complete, the output of these comparators is allowed to reset the flip-flop. When the output of either one of the two comparators goes high, the flip-flop is reset and the GATE output goes low. The GATE goes low until the SR flip-flop is set by the oscillator. Assuming a 30% ripple in the inductor, the current sense resistor  $R_{CS}$  can be set using:

$$R_{CS} = \frac{0.25V(\text{or } V_{LD})}{1.15 \cdot I_{LED}}$$

Constant frequency peak current mode control has an inherent disadvantage – at duty cycles greater than 0.5, the control scheme goes into subharmonic oscillations. To prevent this, an artificial slope is typically added to the current sense waveform. This slope compensation scheme will affect the accuracy of the LED current in the present form. However, a constant off-time peak current control scheme does not have this problem and can easily operate at duty cycles greater than 0.5. This control scheme also gives inherent input voltage rejection, making the LED current almost insensitive to input voltage variations. However, this scheme leads to variable frequency operation and the frequency range depends greatly on the input and output voltage variation. Using HV9910C, it is easy to switch between the two modes of operation by changing one connection (see [Section 3.3 “Oscillator”](#)).

### 3.1 Input Voltage Regulator

HV9910C can be powered directly from its  $V_{IN}$  pin and can work from 15 - 450VDC at its  $V_{IN}$  pin. When a voltage is applied at the  $V_{IN}$  pin, HV9910C maintains a constant 7.5V at the  $V_{DD}$  pin. This voltage is used to power the IC and any external-resistor dividers needed

to control the IC. The  $V_{DD}$  pin must be bypassed by a low-ESR capacitor to provide a low impedance path for the high frequency current of the output GATE driver.

HV9910C can also be operated by supplying a voltage at the  $V_{DD}$  pin greater than the internally regulated voltage. This will turn off the internal linear regulator of the IC and the HV9910C will operate directly off the voltage supplied at the  $V_{DD}$  pin. This external voltage at the  $V_{DD}$  pin should not exceed 12V.

Although the  $V_{IN}$  pin of the HV9910C is rated up to 450V, the actual maximum voltage that can be applied is limited by the power dissipation in the IC. For example, if an 8-lead SOIC HV9910C (junction to ambient thermal resistance  $R_{\theta j-a} = 101^{\circ}\text{C/W}$ ) draws about  $I_{IN} = 2.0\text{mA}$  from the  $V_{IN}$  pin, and has a maximum allowable temperature rise of the junction temperature limited to  $\Delta T = 75^{\circ}\text{C}$ , the maximum voltage at the  $V_{IN}$  pin would be:

$$\begin{aligned} V_{IN(\text{MAX})} &= \frac{\Delta T}{R_{\theta j-a}} \cdot \frac{1}{I_{IN}} \\ &= \frac{75^{\circ}\text{C}}{101^{\circ}\text{C/W}} \cdot \frac{1}{2\text{mA}} \\ &= 371\text{V} \end{aligned}$$

In these cases, to operate HV9910C from higher input voltages, a Zener diode can be added in series with the  $V_{IN}$  pin to divert some of the power loss from HV9910C to the Zener diode. In the above example, using a 100V Zener diode will allow the circuit to easily work up to 450V.

**Note:** The Zener diode will increase the minimum input voltage required to turn on the HV9910C to 115V.

The input current drawn from the  $V_{IN}$  pin is a sum of the 1.5mA (maximum) current drawn by the internal circuit and the current drawn by the GATE driver. The GATE driver depends on the switching frequency and the GATE charge of the external FET.

$$I_{IN} = 1.5\text{mA} + Q_g \cdot f_s$$

In the above equation,  $f_s$  is the switching frequency and  $Q_g$  is the GATE charge of the external FET, which can be obtained from the data sheet of the FET.

### 3.2 Current Sense

The current sense input of HV9910C goes to the non-inverting inputs of two comparators. The inverting terminal of one comparator is tied to an internal 250mV reference, whereas the inverting terminal of the other comparator is connected to the LD pin. The outputs of both these comparators are fed into an OR GATE and

# HV9910C

the output of the OR GATE is fed into the reset pin of the flip-flop. Thus, the comparator which has the lowest voltage at the inverting terminal determines when the GATE output is turned off.

The outputs of the comparators also include a 150-280ns blanking time which prevents spurious turn-offs of the external FET due to the turn-on spike normally present in peak-current mode control. In rare cases, this internal blanking might not be enough to filter out the turn-on spike. In these instances, an external RC filter needs to be added between the external sense resistor (RCS) and the CS pin.

Please note that the comparators are fast (with a typical 80ns response time). A proper layout minimizing external inductances will prevent false triggering of these comparators.

### 3.3 Oscillator

The oscillator in HV9910C is controlled by a single resistor connected at the RT pin. The equation governing the oscillator time period  $T_{osc}$  is given by:

$$T_{osc}(\mu s) = \frac{R_{osc}(k\Omega)}{25}$$

If the resistor is connected between RT and GND, HV9910C operates in a constant frequency mode and the above equation determines the time period. If the resistor is connected between RT and GATE, HV9910C operates in a constant off-time mode and the above equation determines the off-time.

### 3.4 Gate Output

The gate output of the HV9910C is used to drive an external FET. It is recommended that the GATE charge of the external FET be less than 25nC for switching frequencies  $\leq 100$ kHz and less than 15nC for switching frequencies  $> 100$ kHz.

### 3.5 Linear Dimming

The Linear Dimming pin is used to control the LED current. There are two cases when it may be necessary to use the Linear Dimming pin.

1. In some cases, when using the internal 250mV, it may not be possible to find the exact  $R_{CS}$  value required to obtain the LED current. In these cases, an external voltage divider from the  $V_{DD}$  pin can be connected to the LD pin to obtain a voltage (less than 250mV) corresponding to the desired voltage across RCS.
2. Linear dimming may be desired to adjust the current level to reduce the intensity of the LEDs. In these cases, an external 0-250mV voltage

can be connected to the LD pin to adjust the LED current during operation.

To use the internal 250mV, the LD pin can be connected to  $V_{DD}$ .

**Note:** Although the LD pin can be pulled to GND, the output current will not go to zero. This is due to the presence of a minimum on-time, which is equal to the sum of the blanking time and the delay to output time, or about 450ns. This minimum on-time causes the FET to be on for a minimum of 450ns, and thus the LED current when LD = GND is not zero. This current is also dependent on the input voltage, inductance value, forward voltage of the LEDs, and circuit parasitics. To get zero LED current, the PWMD pin has to be used.

### 3.6 PWM Dimming

PWM Dimming can be achieved by driving the PWMD pin with a low frequency square wave signal. When the PWM signal is zero, the GATE driver is turned off; when the PWM signal is high, the GATE driver is enabled. The PWMD signal does not turn off the other parts of the IC, therefore, the response of HV9910C to the PWMD signal is almost instantaneous. The rate of rise and fall of the LED current is thus determined solely by the rise and fall times of the inductor current.

To disable PWM Dimming and enable the HV9910C permanently, connect the PWMD pin to  $V_{DD}$ .

### 3.7 Over-Temperature Protection

The auto-recoverable thermal shutdown at 140°C (typ.) junction temperature with 20°C hysteresis is featured to avoid thermal runaway. When the junction temperature reaches  $T_{SD} = 140^\circ\text{C}$  (typ.), HV9910C enters a low power consumption shut-down mode with  $I_{IN} < 350\mu\text{A}$ .



**FIGURE 3-1: INTERNAL BLOCK DIAGRAM**

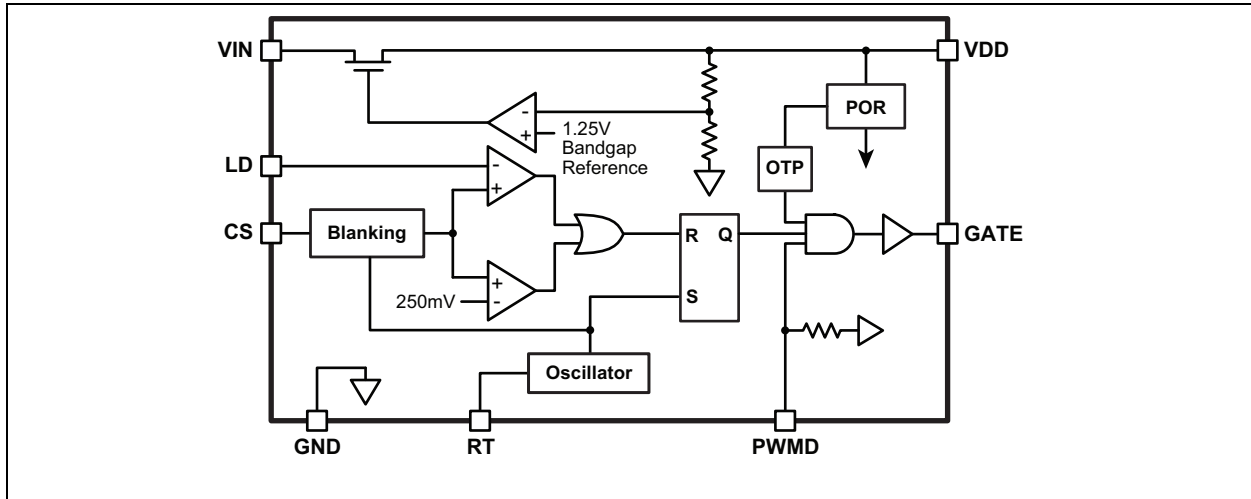

# HV9910C

---

## 4.0 PACKAGING INFORMATION

### 4.1 Package Marking Information

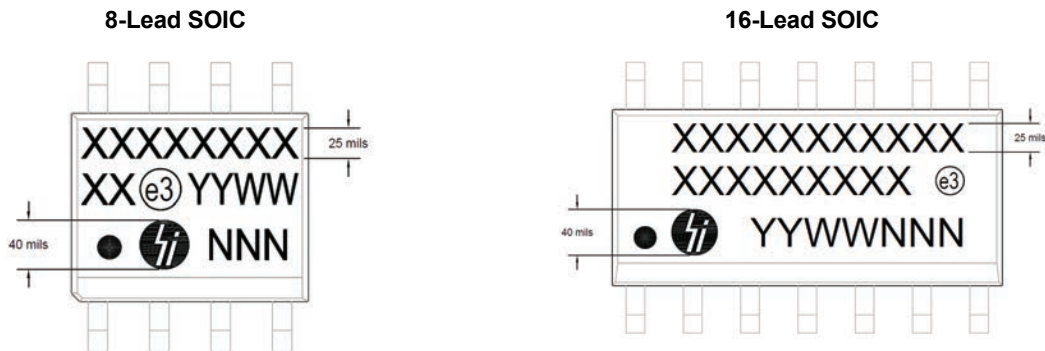

- X = Product Code
- YY = Year Sealed
- WW = Week Sealed
- NNN = Traceability Code
- e# = JEDEC Symbol
- = Pin 1 Indicator

Note: The JEDEC environmental marking symbols (e#) illustrated are examples only, and might not reflect the actual value for the listed package code.

**FIGURE 4-1: 8-LEAD SOIC (NARROW BODY) PACKAGE OUTLINE (LG)**

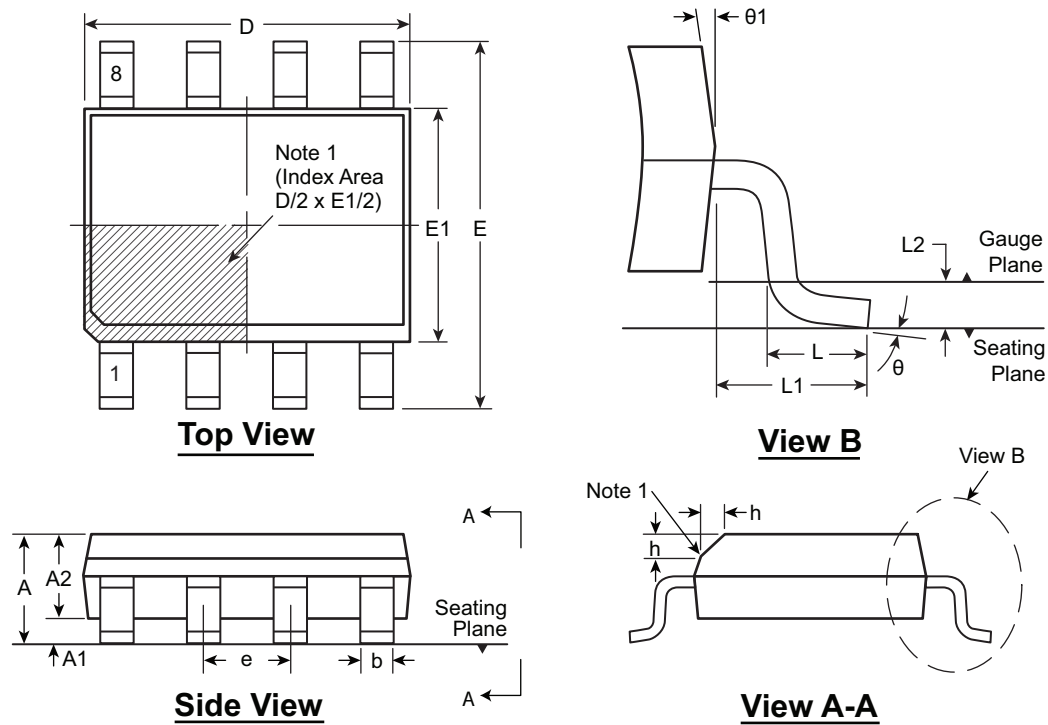

**Notes:**

1. This chamfer feature is optional. A Pin 1 identifier must be located in the index area indicated. The Pin 1 identifier can be: a molded mark/identifier; an embedded metal marker; or a printed indicator.

Symbol		A	A1	A2	b	D	E	E1	e	h	L	L1	L2	$\theta$	$\theta1$
Dimension (mm)	MIN	1.35*	0.10	1.25	0.31	4.80*	5.80*	3.80*	1.27 BSC	0.25	0.40	1.04 REF	0.25 BSC	0°	5°
	NOM	-	-	-	-	4.90	6.00	3.90		-	-			-	-
	MAX	1.75	0.25	1.65*	0.51	5.00*	6.20*	4.00*		0.50	1.27			8°	15°

JEDEC Registration MS-012, Variation AA, Issue E, Sep 2005.

\* This dimension is not specified in the JEDEC drawing.

† This dimension differs from the JEDEC drawing.

Drawings not to scale.

# HV9910C

FIGURE 4-2: 16-LEAD SOIC (NARROW BODY) PACKAGE OUTLINE (NG)

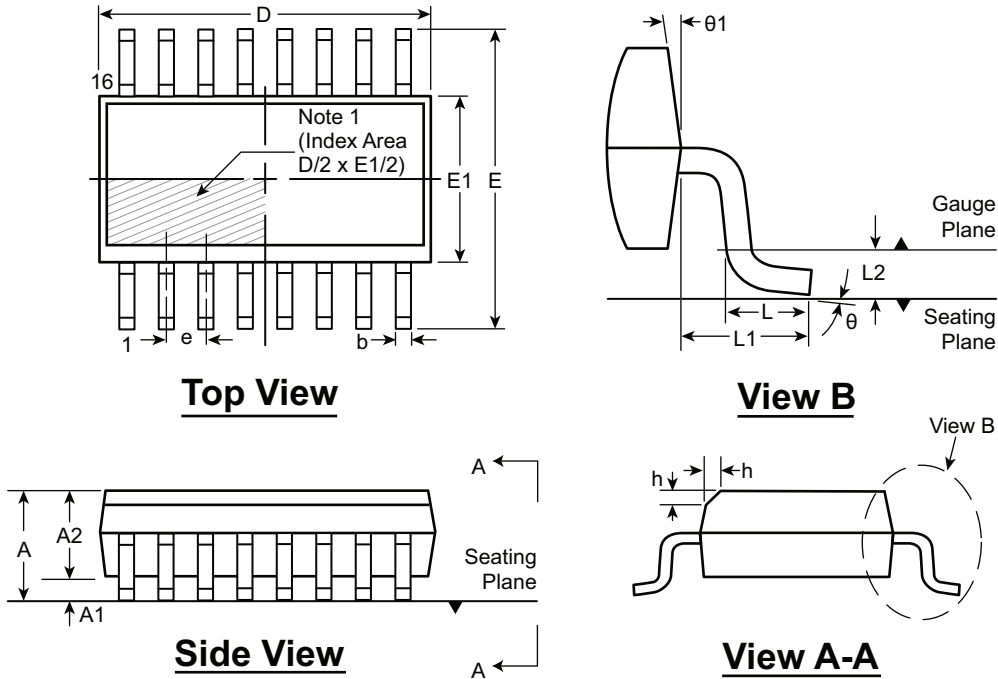

Notes:

1. This chamfer feature is optional. A Pin 1 identifier must be located in the index area indicated. The Pin 1 identifier can be: a molded mark/identifier; an embedded metal marker; or a printed indicator.

Symbol		A	A1	A2	b	D	E	E1	e	h	L	L1	L2	θ	θ1
Dimension (mm)	MIN	1.35*	0.10	1.25	0.31	9.80*	5.80*	3.80*	1.27 BSC	0.25	0.40	1.04 REF	0.25 BSC	0°	5°
	NOM	-	-	-	-	9.90	6.00	3.90		-	-			-	-
	MAX	1.75	0.25	1.65*	0.51	10.00*	6.20*	4.00*		0.50	1.27			8°	15°

JEDEC Registration MS-012, Variation AC, Issue E, Sep 2005.

\* This dimension is not specified in the JEDEC drawing.

† This dimension differs from the JEDEC drawing.

Drawings not to scale.

**FIGURE 4-3: 8-LEAD SOIC (NARROW BODY) PACKAGE OUTLINE (SG)**

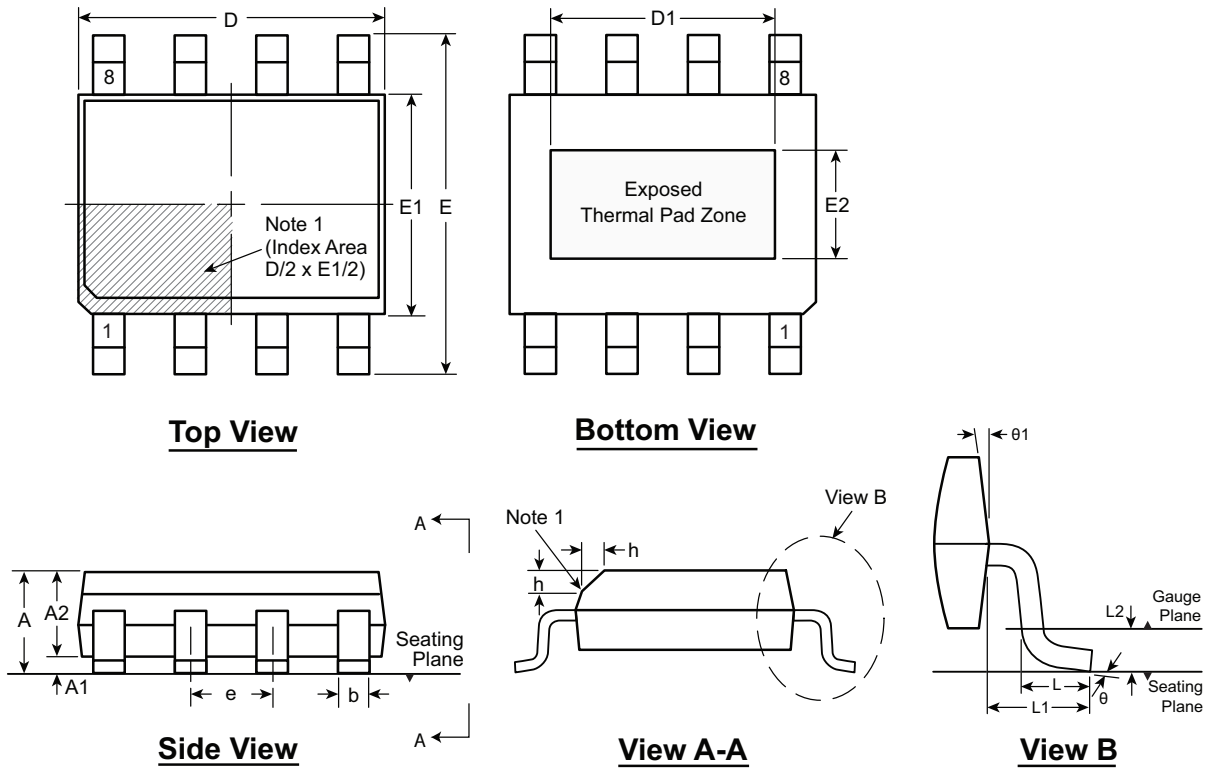

**Notes:**

1. This chamfer feature is optional. A Pin 1 identifier must be located in the index area indicated. The Pin 1 identifier can be: a molded mark/identifier; an embedded metal marker; or a printed indicator.

Symbol	A	A1	A2	b	D	D1	E	E1	E2	e	h	L	L1	L2	θ	θ1					
Dimension (mm)	MIN	1.25*	0.00	1.25	0.31	4.80*	3.30†	5.80*	3.80*	2.29†	1.27 BSC	0.25	0.40	1.04 REF	0.25	BSC	0°	5°			
	NOM	-	-	-	-	4.90	-	6.00	3.90	-		-	-		-		-	-	-	-	-
	MAX	1.70	0.15	1.55*	0.51	5.00*	3.81†	6.20*	4.00*	2.79†		0.50	1.27		-		-	8°	15°		

JEDEC Registration MS-012, Variation BA, Issue E, Sep 2005.

\* This dimension is not specified in the JEDEC drawing.

† This dimension differs from the JEDEC drawing.

Drawings not to scale.

# HV9910C

---

## APPENDIX A: REVISION HISTORY

### Revision A (August 2014)

- Original Release of this Document.

## THE MICROCHIP WEB SITE

Microchip provides online support via our WWW site at [www.microchip.com](http://www.microchip.com). This web site is used as a means to make files and information easily available to customers. Accessible by using your favorite Internet browser, the web site contains the following information:

- **Product Support** – Data sheets and errata, application notes and sample programs, design resources, user's guides and hardware support documents, latest software releases and archived software
- **General Technical Support** – Frequently Asked Questions (FAQ), technical support requests, online discussion groups, Microchip consultant program member listing
- **Business of Microchip** – Product selector and ordering guides, latest Microchip press releases, listing of seminars and events, listings of Microchip sales offices, distributors and factory representatives

## CUSTOMER CHANGE NOTIFICATION SERVICE

Microchip's customer notification service helps keep customers current on Microchip products. Subscribers will receive e-mail notification whenever there are changes, updates, revisions or errata related to a specified product family or development tool of interest.

To register, access the Microchip web site at [www.microchip.com](http://www.microchip.com). Under "Support", click on "Customer Change Notification" and follow the registration instructions.

## CUSTOMER SUPPORT

Users of Microchip products can receive assistance through several channels:

- Distributor or Representative
- Local Sales Office
- Field Application Engineer (FAE)
- Technical Support

Customers should contact their distributor, representative or Field Application Engineer (FAE) for support. Local sales offices are also available to help customers. A listing of sales offices and locations is included in the back of this document.

**Technical support is available through the web site at: <http://microchip.com/support>**

# HV9910C

## PRODUCT IDENTIFICATION SYSTEM

To order or obtain information, e.g., on pricing or delivery, refer to the factory or the listed sales office.

<u>PART NO.</u>	<u>XX</u>	-	<u>X</u>	-	<u>X</u>
Device	Package Options		Environmental		Reel
Device:	HV9910C= Universal High-Brightness LED Driver				
Package:	LG	=	8-lead SOIC		
	NG	=	16-lead SOIC		
	SG	=	8-lead SOIC with head slug		
Environmental	G	=	Lead (Pb)-free/ROHS-compliant package		
Reel:	(nothing)	=	Reel for LG and SG packages, Tube for NG package		
	M934	=	Reel for NG package		

**Examples:**

- a) HV9910CLG-G: 8-lead SOIC package, 2500/Reel.
- b) HV9910CNG-G: 16-lead SOIC package, 45/Tube
- c) HV9910CNG-G-M934: 16-lead SOIC package, 2500/Reel.
- d) HV9910CSG-G: 8-lead SOIC package with heat slug, 2500/Reel.



---

**Note the following details of the code protection feature on Microchip devices:**

- Microchip products meet the specification contained in their particular Microchip Data Sheet.
- Microchip believes that its family of products is one of the most secure families of its kind on the market today, when used in the intended manner and under normal conditions.
- There are dishonest and possibly illegal methods used to breach the code protection feature. All of these methods, to our knowledge, require using the Microchip products in a manner outside the operating specifications contained in Microchip's Data Sheets. Most likely, the person doing so is engaged in theft of intellectual property.
- Microchip is willing to work with the customer who is concerned about the integrity of their code.
- Neither Microchip nor any other semiconductor manufacturer can guarantee the security of their code. Code protection does not mean that we are guaranteeing the product as “unbreakable.”

Code protection is constantly evolving. We at Microchip are committed to continuously improving the code protection features of our products. Attempts to break Microchip's code protection feature may be a violation of the Digital Millennium Copyright Act. If such acts allow unauthorized access to your software or other copyrighted work, you may have a right to sue for relief under that Act.

---

Information contained in this publication regarding device applications and the like is provided only for your convenience and may be superseded by updates. It is your responsibility to ensure that your application meets with your specifications. MICROCHIP MAKES NO REPRESENTATIONS OR WARRANTIES OF ANY KIND WHETHER EXPRESS OR IMPLIED, WRITTEN OR ORAL, STATUTORY OR OTHERWISE, RELATED TO THE INFORMATION, INCLUDING BUT NOT LIMITED TO ITS CONDITION, QUALITY, PERFORMANCE, MERCHANTABILITY OR FITNESS FOR PURPOSE. Microchip disclaims all liability arising from this information and its use. Use of Microchip devices in life support and/or safety applications is entirely at the buyer's risk, and the buyer agrees to defend, indemnify and hold harmless Microchip from any and all damages, claims, suits, or expenses resulting from such use. No licenses are conveyed, implicitly or otherwise, under any Microchip intellectual property rights.

#### **Trademarks**

The Microchip name and logo, the Microchip logo, dsPIC, FlashFlex, KEELOQ, KEELOQ logo, MPLAB, PIC, PICmicro, PICSTART, PIC<sup>32</sup> logo, rPIC, SST, SST Logo, SuperFlash and UNI/O are registered trademarks of Microchip Technology Incorporated in the U.S.A. and other countries.

FilterLab, Hampshire, HI-TECH C, Linear Active Thermistor, MTP, SEEVAL and The Embedded Control Solutions Company are registered trademarks of Microchip Technology Incorporated in the U.S.A.

Silicon Storage Technology is a registered trademark of Microchip Technology Inc. in other countries.

Analog-for-the-Digital Age, Application Maestro, BodyCom, chipKIT, chipKIT logo, CodeGuard, dsPICDEM, dsPICDEM.net, dsPICworks, dsSPEAK, ECAN, ECONOMONITOR, FanSense, HI-TIDE, In-Circuit Serial Programming, ICSP, Mindi, MiWi, MPASM, MPF, MPLAB Certified logo, MPLIB, MPLINK, mTouch, Omniclient Code Generation, PICC, PICC-18, PICDEM, PICDEM.net, PICkit, PICTail, REAL ICE, rLAB, Select Mode, SQI, Serial Quad I/O, Total Endurance, TSHARC, UniWinDriver, WiperLock, ZENA and Z-Scale are trademarks of Microchip Technology Incorporated in the U.S.A. and other countries.

SQTP is a service mark of Microchip Technology Incorporated in the U.S.A.

GestIC and ULPP are registered trademarks of Microchip Technology Germany II GmbH & Co. KG, a subsidiary of Microchip Technology Inc., in other countries.

All other trademarks mentioned herein are property of their respective companies.

© 2014, Microchip Technology Incorporated, Printed in the U.S.A., All Rights Reserved.

 Printed on recycled paper.

ISBN: 978-1-63276-529-1

**QUALITY MANAGEMENT SYSTEM**  
**CERTIFIED BY DNV**  
**== ISO/TS 16949 ==**

*Microchip received ISO/TS-16949:2009 certification for its worldwide headquarters, design and wafer fabrication facilities in Chandler and Tempe, Arizona; Gresham, Oregon and design centers in California and India. The Company's quality system processes and procedures are for its PIC<sup>®</sup> MCUs and dsPIC<sup>®</sup> DSCs, KEELOQ<sup>®</sup> code hopping devices, Serial EEPROMs, microperipherals, nonvolatile memory and analog products. In addition, Microchip's quality system for the design and manufacture of development systems is ISO 9001:2000 certified.*



# MICROCHIP

## Worldwide Sales and Service

### AMERICAS

**Corporate Office**  
2355 West Chandler Blvd.  
Chandler, AZ 85224-6199  
Tel: 480-792-7200  
Fax: 480-792-7277  
Technical Support:  
<http://www.microchip.com/support>  
Web Address:  
[www.microchip.com](http://www.microchip.com)

**Atlanta**  
Duluth, GA  
Tel: 678-957-9614  
Fax: 678-957-1455

**Austin, TX**  
Tel: 512-257-3370

**Boston**  
Westborough, MA  
Tel: 774-760-0087  
Fax: 774-760-0088

**Chicago**  
Itasca, IL  
Tel: 630-285-0071  
Fax: 630-285-0075

**Cleveland**  
Independence, OH  
Tel: 216-447-0464  
Fax: 216-447-0643

**Dallas**  
Addison, TX  
Tel: 972-818-7423  
Fax: 972-818-2924

**Detroit**  
Novi, MI  
Tel: 248-848-4000

**Houston, TX**  
Tel: 281-894-5983

**Indianapolis**  
Noblesville, IN  
Tel: 317-773-8323  
Fax: 317-773-5453

**Los Angeles**  
Mission Viejo, CA  
Tel: 949-462-9523  
Fax: 949-462-9608

**New York, NY**  
Tel: 631-435-6000

**San Jose, CA**  
Tel: 408-735-9110

**Canada - Toronto**  
Tel: 905-673-0699  
Fax: 905-673-6509

### ASIA/PACIFIC

**Asia Pacific Office**  
Suites 3707-14, 37th Floor  
Tower 6, The Gateway  
Harbour City, Kowloon  
Hong Kong  
Tel: 852-2943-5100  
Fax: 852-2401-3431

**Australia - Sydney**  
Tel: 61-2-9868-6733  
Fax: 61-2-9868-6755

**China - Beijing**  
Tel: 86-10-8569-7000  
Fax: 86-10-8528-2104

**China - Chengdu**  
Tel: 86-28-8665-5511  
Fax: 86-28-8665-7889

**China - Chongqing**  
Tel: 86-23-8980-9588  
Fax: 86-23-8980-9500

**China - Hangzhou**  
Tel: 86-571-8792-8115  
Fax: 86-571-8792-8116

**China - Hong Kong SAR**  
Tel: 852-2943-5100  
Fax: 852-2401-3431

**China - Nanjing**  
Tel: 86-25-8473-2460  
Fax: 86-25-8473-2470

**China - Qingdao**  
Tel: 86-532-8502-7355  
Fax: 86-532-8502-7205

**China - Shanghai**  
Tel: 86-21-5407-5533  
Fax: 86-21-5407-5066

**China - Shenyang**  
Tel: 86-24-2334-2829  
Fax: 86-24-2334-2393

**China - Shenzhen**  
Tel: 86-755-8864-2200  
Fax: 86-755-8203-1760

**China - Wuhan**  
Tel: 86-27-5980-5300  
Fax: 86-27-5980-5118

**China - Xian**  
Tel: 86-29-8833-7252  
Fax: 86-29-8833-7256

**China - Xiamen**  
Tel: 86-592-2388138  
Fax: 86-592-2388130

**China - Zhuhai**  
Tel: 86-756-3210040  
Fax: 86-756-3210049

### ASIA/PACIFIC

**India - Bangalore**  
Tel: 91-80-3090-4444  
Fax: 91-80-3090-4123

**India - New Delhi**  
Tel: 91-11-4160-8631  
Fax: 91-11-4160-8632

**India - Pune**  
Tel: 91-20-3019-1500

**Japan - Osaka**  
Tel: 81-6-6152-7160  
Fax: 81-6-6152-9310

**Japan - Tokyo**  
Tel: 81-3-6880-3770  
Fax: 81-3-6880-3771

**Korea - Daegu**  
Tel: 82-53-744-4301  
Fax: 82-53-744-4302

**Korea - Seoul**  
Tel: 82-2-554-7200  
Fax: 82-2-558-5932 or  
82-2-558-5934

**Malaysia - Kuala Lumpur**  
Tel: 60-3-6201-9857  
Fax: 60-3-6201-9859

**Malaysia - Penang**  
Tel: 60-4-227-8870  
Fax: 60-4-227-4068

**Philippines - Manila**  
Tel: 63-2-634-9065  
Fax: 63-2-634-9069

**Singapore**  
Tel: 65-6334-8870  
Fax: 65-6334-8850

**Taiwan - Hsin Chu**  
Tel: 886-3-5778-366  
Fax: 886-3-5770-955

**Taiwan - Kaohsiung**  
Tel: 886-7-213-7830

**Taiwan - Taipei**  
Tel: 886-2-2508-8600  
Fax: 886-2-2508-0102

**Thailand - Bangkok**  
Tel: 66-2-694-1351  
Fax: 66-2-694-1350

### EUROPE

**Austria - Wels**  
Tel: 43-7242-2244-39  
Fax: 43-7242-2244-393

**Denmark - Copenhagen**  
Tel: 45-4450-2828  
Fax: 45-4485-2829

**France - Paris**  
Tel: 33-1-69-53-63-20  
Fax: 33-1-69-30-90-79

**Germany - Dusseldorf**  
Tel: 49-2129-3766400

**Germany - Munich**  
Tel: 49-89-627-144-0  
Fax: 49-89-627-144-44

**Germany - Pforzheim**  
Tel: 49-7231-424750

**Italy - Milan**  
Tel: 39-0331-742611  
Fax: 39-0331-466781

**Italy - Venice**  
Tel: 39-049-7625286

**Netherlands - Drunen**  
Tel: 31-416-690399  
Fax: 31-416-690340

**Poland - Warsaw**  
Tel: 48-22-3325737

**Spain - Madrid**  
Tel: 34-91-708-08-90  
Fax: 34-91-708-08-91

**Sweden - Stockholm**  
Tel: 46-8-5090-4654

**UK - Wokingham**  
Tel: 44-118-921-5800  
Fax: 44-118-921-5820

03/25/14



## Стандарт Электрон Связь

Мы молодая и активно развивающаяся компания в области поставок электронных компонентов. Мы поставляем электронные компоненты отечественного и импортного производства напрямую от производителей и с крупнейших складов мира.

Благодаря сотрудничеству с мировыми поставщиками мы осуществляем комплексные и плановые поставки широчайшего спектра электронных компонентов.

Собственная эффективная логистика и склад в обеспечивает надежную поставку продукции в точно указанные сроки по всей России.

Мы осуществляем техническую поддержку нашим клиентам и предпродажную проверку качества продукции. На все поставляемые продукты мы предоставляем гарантию .

Осуществляем поставки продукции под контролем ВП МО РФ на предприятия военно-промышленного комплекса России , а также работаем в рамках 275 ФЗ с открытием отдельных счетов в уполномоченном банке. Система менеджмента качества компании соответствует требованиям ГОСТ ISO 9001.

Минимальные сроки поставки, гибкие цены, неограниченный ассортимент и индивидуальный подход к клиентам являются основой для выстраивания долгосрочного и эффективного сотрудничества с предприятиями радиоэлектронной промышленности, предприятиями ВПК и научно-исследовательскими институтами России.

С нами вы становитесь еще успешнее!

### Наши контакты:

**Телефон:** +7 812 627 14 35

**Электронная почта:** [sales@st-electron.ru](mailto:sales@st-electron.ru)

**Адрес:** 198099, Санкт-Петербург,  
Промышленная ул, дом № 19, литера Н,  
помещение 100-Н Офис 331