

Atmel LED Driver-MSL3162

16-string, RGB and White LED Drivers with Adaptive Power Control and 1MHz I²C/SMBus Serial Interface

Datasheet Brief



Atmel LED Driver-MSL3162

16-string, RGB and White LED Drivers with Adaptive Power Control and 1MHz I²C/SMBus Serial Interface

General Description

Atmel LED Driver-MSL3162 is a compact, high-power, 16-parallel-string LED driver. It uses internal current control MOSFETs to sink up to 100mA per LED string with better than 3% accuracy and with up to 10 series white LEDs per string, or 160 LEDs per MSL3162.

The advanced PWM engine is easily synchronized to the video signal and refresh timing using a built-in DLL multiplier and sync dividers. Per-string phase adjustment reduces unwanted LCD artifacts such as motion blur. Up to 16 MSL3162s can share the same 1MHz I²C/SMBus-compatible serial interface, which is fast enough for frame-by-frame LED string intensity control of 16 MSL3162s, or 2560 white LEDs in total.

The MSL3162 adaptively controls the voltage powering the LED strings using patented Atmel's Efficiency Optimizer control. The Efficiency Optimizer minimizes LED driver power losses while maintaining high current accuracy.

The MSL3162 uses 6-bit analog (LED current) dimming as well as 10-bit PWM dimming control. PWM dimming is derived from the product of the 8-bit individual string PWM setting, the 6-bit global intensity, and the 8-bit thermal derating. One external resistor provides the global reference current for all the LED strings.

The MSL3162 features fault monitoring of open circuit, short circuit, and over-temperature conditions, with fault status available through the dedicated FLTB output as well as the I²C/SMBus serial interface. It supports both individual device I²C read/write and broadcast write commands, allowing multiple MSL3162s to be configured simultaneously.

The MSL3162 includes on-chip user EEPROM, allowing customization of the internal register power-up defaults.

The MSL3162 is offered in a lead-free, halogen-free, RoHS-compliant package with a -40°C to +85°C temperature range.

Applications

Long Life, Efficient LED Backlighting for:

- Televisions and Desktop Monitors
- Medical and Industrial Instrumentation
- Automotive Audio-visual Displays

Digital Signage

Solid-State Lighting

Ordering Information

PART	DESCRIPTION	PACKAGE
MSL3162BT	16-ch LED driver	40-pin, 6x6x0.75mm TQFN

Atmel LED Driver-MSL3162

16-string, RGB and White LED Drivers with Adaptive Power Control and 1MHz I²C/SMBus Serial Interface

Key Features

- 100ma Maximum Peak LED String Current
- Adaptive Power Correction Optimizes LED Supplies
- Multiple MSL3162s Can Share String Supplies
- MSL3162s Automatically Negotiate The Lowest Supply Voltage That Maintains Regulation Across All MSL3162s
- Better Than $\pm 3\%$ Current Accuracy and Balance
- Single Resistor Sets Peak Current For All LED Strings
- Individual LED String Intensity (Peak Current And PWM)
- Individual LED String Phase Controls
- Global LED Intensity Control – I²C Or PWM Input Pin
- Programmable String Phase Delays Reduce Motion Blur
- Supports Adaptive, Real-Time 2D Area Dimming For Highest Dynamic Range LCD TVs and Monitors
- Flexible Video Frame (VSYNC) And Line (HSYNC) Synchronization With DLL Multiplier and Dividers
- Sync Loss Detectors Optionally Disable LED Strings
- Open Circuit and Short Circuit Fault Detection
- Individual Fault Detection Enables For Each String
- 1Mhz I²C/SMBus Interface with 16 Slave Addresses
- I²C/SMBus Broadcast Mode Simplifies Configuration
- User EEPROM Saves Power-On Default Settings
- Die Over-Temperature Cutoff Protection
- $< 1\mu\text{a}$ LED String Current Sink Off Leakage Current
- Automatic LED Current Temperature Compensation
- -40°C To $+85^{\circ}\text{C}$ Operating Temperature Range
- Lead-Free, Halogen-Free, RoHS-Compliant Package

Application Circuit

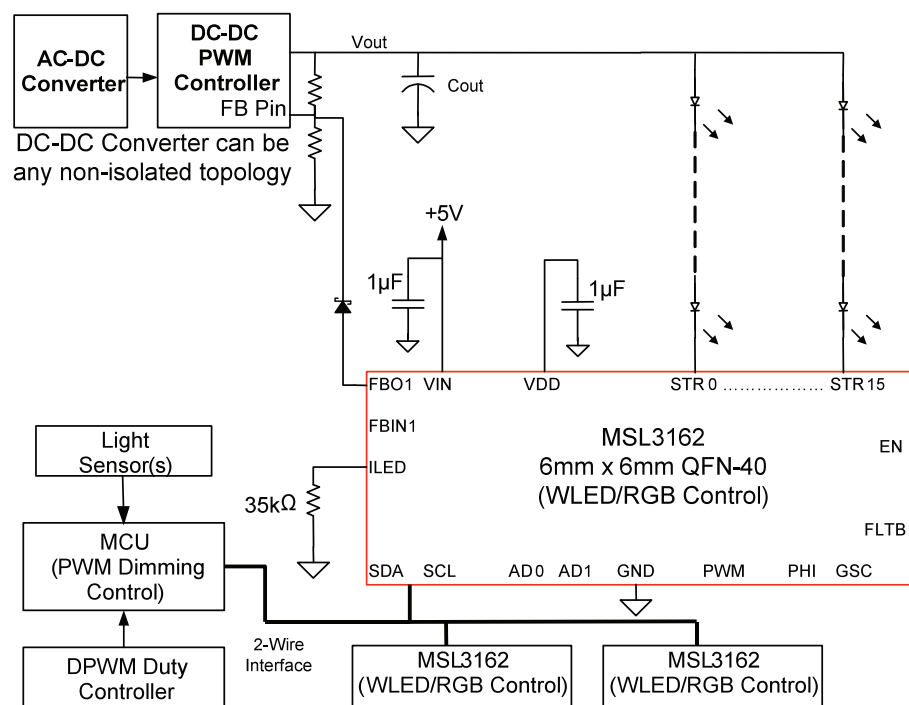



Quick Start Guide

The MSL3162 is an LED string driver that drives, monitors, and dims up to 160 white LEDs (up to 10 series and up to 16 parallel) at high efficiency for LCD backlighting and signage applications. This section summarizes the capabilities of the MSL3162 for quick evaluation.

How Many LEDs and Drivers?

The MSL3162 drives 16 strings of series-connected LEDs. The maximum number of LEDs per string is limited to 10 white LEDs by the 40V maximum string voltage rating. More series LEDs can be driven if their forward voltage (V_F) is lower. When an LED string is turned off, the voltage across the LEDs does not drop to zero. This allows more series LEDs to be driven, but eliminates the MSL3162's ability to sustain a shorted LED string.

Sixteen MSL3162s can share an I²C/SMBus serial interface, with both individual and broadcast (all MSL3162s on a bus) addressing. The high total LED drive capability of multiple bussed MSL3162s makes the driver suitable for LCD TV and monitor backlights as well as LED signage and general lighting. The LED drive capability is summarized in Table 1.

Table 1. Atmel LED Driver MSL3162 LED Drive Capability

LED TYPE	$V_{F(MAX)}$	LEDs IN STRING	PER MSL3162	16 X MSL3162s	LED POWER PER MSL3162	LED POWER 16 X MSL3162s
White, Green, Blue	3.6V	10 LEDs	160 LEDs	2560 LEDs	34W (at 60mA string current)	544W (at 60mA string current)
Red	2.4V	15 LEDs	240 LEDs	3840 LEDs		
RGB	-	10 LEDs	50 RGB LEDs	800 RGB LEDs	26W (at 60mA)	415W (at 60mA)

LEDs, Power Supplies (PSUs), and Efficiency Optimizers

The MSL3162 obtains high efficiency by adjusting up to three LED string power supplies to deliver the minimum necessary voltage to accurately drive all LED strings connected to each LED string supply via the three Efficiency Optimizers. Multiple MSL3162s sharing string supplies automatically negotiate the voltage among themselves using the FBI/FBO pins. No system intervention is needed after initial configuration. Use any appropriate LED string power supply topology, typically a DC-DC boost or buck converter with a controllable resistive feedback voltage divider.

The Efficiency Optimizer sets the LED voltage to maintain regulation on the highest voltage LED string. The better the LED string voltage matching, the lower the dissipation the MSL3162 absorbs, and, therefore, better LED matching improves efficiency. RGB LEDs should be driven by three separate string supplies. Also, consider using multiple string supplies for high-power, single-color systems, such as a white backlight.

Atmel LED Driver-MSL3162

16-string, RGB and White LED Drivers with Adaptive Power Control and 1MHz I²C/SMBus Serial Interface

Timing, PWM, Intensity Controls and Synchronization

The internal PWM dimming is synchronized to the LCD's frame timing through the PHI input (typically VSYNC) and the GSC input (typically HSYNC) to eliminate beating artifacts and maintain high timing accuracy. Suitability for LED backlight architectures is shown in Table 2. LED area dimming for direct backlighting is supported for contrast improvement. Motion blur is reduced by setting each LED string's PWM phasing individually to synchronize PWM off times with the LCD refresh timing for the zone being lit.

Table 2. Atmel LED Driver-MSL3162 LED Common Backlight Drive Architectures

BACKLIGHT TYPE	STRING SUPPLY OPTIONS	MOTION BLUR REMOVAL	LED ZONE MANAGEMENT
White LED – Bottom, edge-lit	Up to three efficiency optimized supplies	No	No
White LED – Top/bottom, edge-lit		No	No
White LED – Four sides, edge-lit		No	No
White LED – Direct, back-lit		Yes - LED strip phasing	Higher contrast ratio (area dimming)
RGB LED – Direct, back-lit	R, G, B efficiency optimized supplies	Yes - LED strip phasing	Higher contrast ratio and color gamut



Package Pin-out

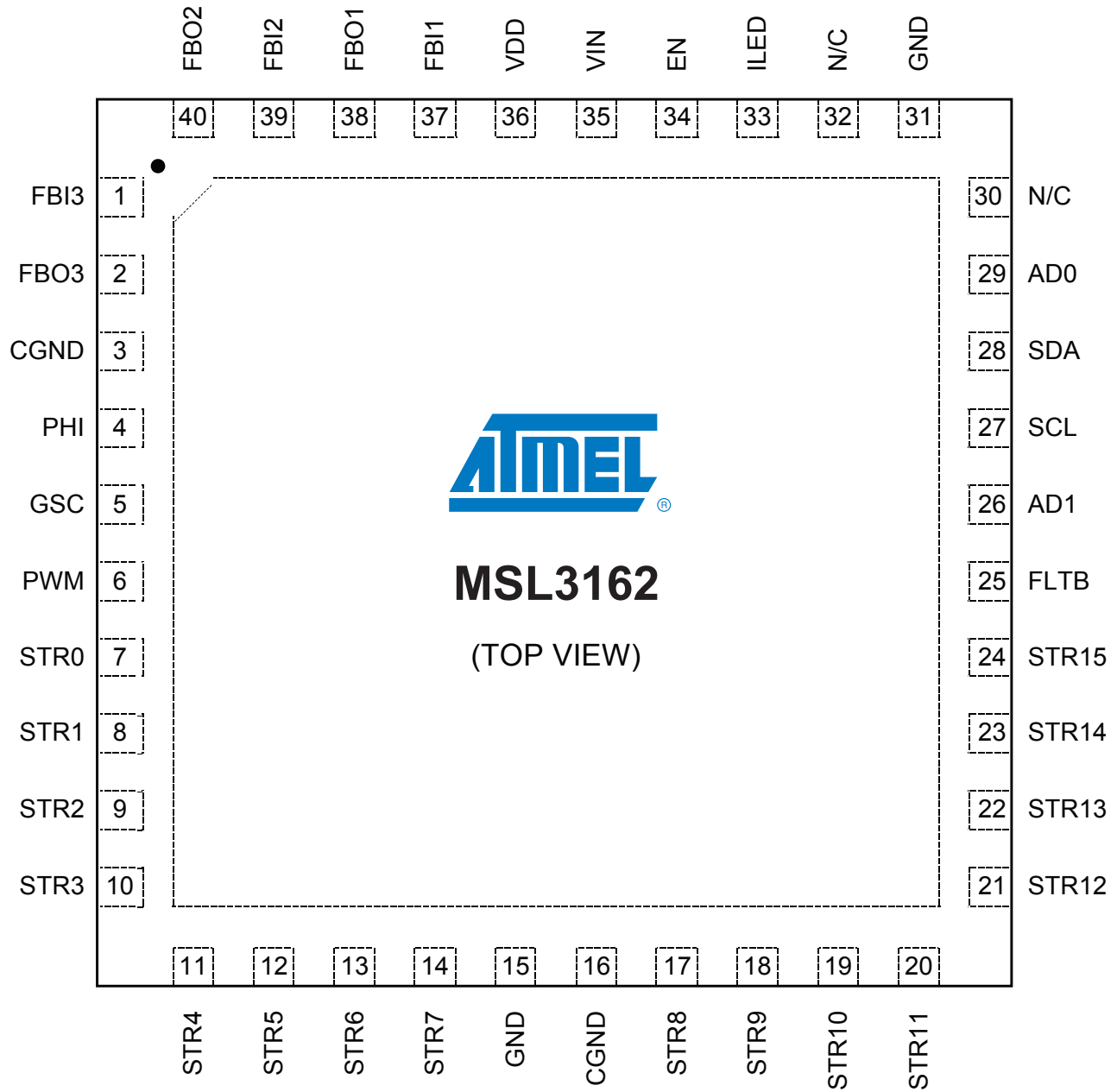

Figure 1. 40-pin, 6mm x 6mm x 0.75mm TQFN (0.5mm pin pitch) with Exposed Pad

Atmel LED Driver-MSL3162

16-string, RGB and White LED Drivers with Adaptive Power Control and 1MHz I²C/SMBus Serial Interface

Package Pin-out

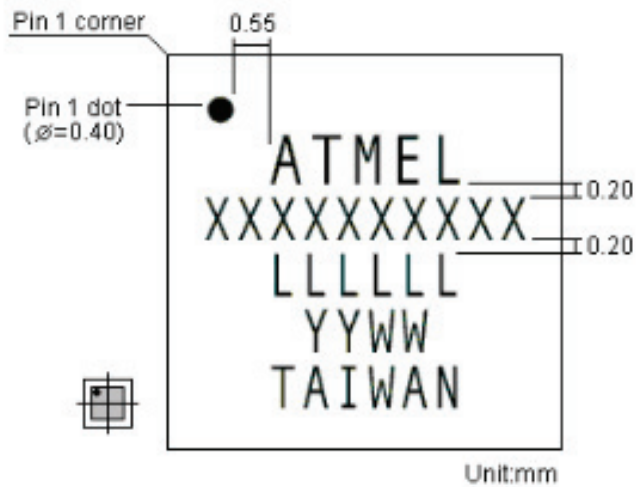

Figure 2. 40-pin TQFN Package Dimensions



Pin Descriptions

Table 3. Pin Descriptions

PIN NAME	PIN NUMBER	PIN DESCRIPTION
FBI1, FBI2, FBI3	37, 39, 1	Efficiency Optimizer feedback inputs When using a common LED voltage over multiple MSL3162s, connect FBIs and FBOs in a chain, with the first FBI grounded and the last FBO controlling the external power source. For standalone operation, connect FBI to GND.
FBO1, FBO2, FBO3	38, 40, 2	Efficiency Optimizer feedback outputs FBO controls the external regulator to dynamically adjust the LED voltage for optimal efficiency. When using a common LED voltage over multiple MSL3162s, connect FBIs and FBOs in a chain, with the first FBI grounded and the last FBO driving the feedback node of an external power source.
CGND	3, 16	Signal ground Connect all CGND and GND pins to system GND and to the exposed pad, EP, using short, wide traces as close to the MSL3162 as possible
GND	15, 31	Power ground Connect all GND and CGND pins to system GND and to the exposed pad, EP, using short, wide traces as close to the MSL3162 as possible
PHI	4	Phase synchronization input Drive PHI with an external signal from 40Hz to 10kHz to synchronize the MSL3162 PWM dimming to the signal at PHI. Connect PHI to GND if unused.
GSC	5	Gate shift clock input GSC sets the PWM dimming resolution. Drive GSC with the video signal gate shift clock up to 5MHz. Connect GSC to GND if unused.
PWM	6	PWM dimming input Drive PWM with a pulse-width modulated signal with a duty ratio ranging from 0% to 100% and frequency from 20Hz to 50kHz to control the brightness of all LED strings.
STR0 to STR15	7 - 14, 17 - 24	STR0 to STR15 LED string current sink outputs Connect the cathode end of each series LED string to one of STR0 to STR15. Connect unused outputs to GND, and disable unused strings using the master control registers.
FLT B	25	Fault indication output (open drain, active low) FLT B sinks current to GND whenever the MSL3162 detects a fault. Once a fault is detected, FLT B remains low until the fault registers have been read.
AD1, AD0	26, 29	I²C slave ID selection inputs AD0 and AD1 select the I ² C slave address used. Connect AD0 and AD1 to either GND, VDD, SCL, or SDA to select the slave ID.
SCL	27	I²C serial clock input SCL is the I ² C serial interface clock input.
SDA	28	I²C serial data I/O SDA is the I ² C serial interface data I/O
N/C	30, 32	Factory connection. Leave unconnected.
ILED	33	Maximum LED current control input Connect a resistor from ILED to GND to set the full-scale LED string current. A 34.8kΩ resistor to GND sets a 60mA sink current through each LED string.
EN	34	Enable input (active high) Drive EN high to turn on the MSL3162, and drive it low to turn it off. For automatic start-up, connect EN to VIN.

Atmel LED Driver-MSL3162

16-string, RGB and White LED Drivers with Adaptive Power Control and 1MHz I²C/SMBus Serial Interface

PIN NAME	PIN NUMBER	PIN DESCRIPTION
VIN	35	Supply voltage input Connect the 5V ±10% supply to VIN. Bypass VIN to GND with a 10µF or greater ceramic capacitor
VDD	36	2.5V internal LDO regulator output VDD is the output of the internal regulator and powers internal logic. Bypass VDD to GND with a 1µF ceramic capacitor
EP	Exposed Pad	Power ground Connect the exposed pad, EP, to system GND and to the GND pins using short, wide traces

Absolute Maximum Ratings

Voltage (With Respect to GND)

VIN, EN.....	-0.3V to +6V
SDA, SCL, AD0, AD1, FLTB.....	-0.3V to +5.5V
PHI, GSC, PWM.....	-0.3V to VIN +0.3V
FBI1, FBI2, FBI3, ILED.....	-0.3V to VDD +0.3V
VDD, FBO1, FBO2, FBO3.....	-0.3V to +2.75V
STR0 to STR15.....	-0.3V to +40V
CGND.....	-0.05V to +0.05V

Current (Into Pin)

VIN.....	50mA
GND.....	1700mA
STR0 to STR15.....	105mA
All other pins.....	-20mA to 20mA

Note 1. Pins 3, 15, 16, 31 and the exposed pad, EP, must all be connected to the system GND using short, wide traces

Note 2. Pins 30 and 32 must be left open circuit

Continuous Power Dissipation at 70°C

40-pin, 6mm x 6mm QFN (see Note 8, Note 9).....	2963mW
---	--------

Ambient Operating Temperature Range, T_A..... -40°C to +85°C

Junction Temperature +125°C

Storage Temperature Range..... -65°C to +125°C

Lead Soldering Temperature, 10s..... +300°C



Electrical Characteristics

(Circuit of Figure 4, $V_{VIN} = 5V$, $V_{EN} = 5V$, default register settings of Table 5, $T_A = -40^{\circ}C$ to $+85^{\circ}C$, unless otherwise noted. Typical values are at $T_A = +25^{\circ}C$)

PARAMETER	CONDITIONS AND NOTES	MIN	TYP	MAX	UNIT
DC ELECTRICAL CHARACTERISTICS					
VIN operating supply voltage		4.5	5	5.5	V
VIN operating supply current	Run mode; all LED strings driven		7	20	mA
VIN shutdown supply current	Sleep mode; SDA, SCL, AD0, AD1, PWM, PHI, GSC at GND or VDD		20	25	μA
VDD regulation voltage		2.35	2.5	2.65	V
Input high voltage SDA, SCL, AD0, AD1, PWM, PHI, GSC		0.7 x VDD			V
Input low voltage SDA, SCL, AD0, AD1, PWM, PHI, GSC				0.3 x VDD	V
Input high voltage EN		1.2			V
Input low voltage EN				0.8	V
Output low voltage SDA	Sinking 6mA			0.4	V
Output low voltage FLTB	Sinking 6mA			0.6	V
I_{LED} regulation voltage	$I_{ILED} = 10\mu A$	340	355	370	mV
FBI_ feedback input current		0		140	μA
FBO_ feedback output current	$V_{FBO} = 0$ to 1.8V	0		55	μA
FBO_ feedback output current step size	FBI_ = GND; $T_A = +25^{\circ}C$	2.5	3	3.6	μA
FBI_ input disable threshold	(Note 10)		140		mV
LED string sink current STR0 to STR15	$R_{ILED} = 34.8k\Omega \pm 0.1\%$; $I_{STRn} = 0x20$; $V_{STRn} = 1V$; $T_A = +25^{\circ}C$	28.5	30	31.5	mA
	$R_{ILED} = 34.8k\Omega \pm 0.1\%$; $I_{STRn} = 0x3F$; $V_{STRn} = 1V$; $T_A = +25^{\circ}C$ (Note 10)		58.9		mA
LED string sink current matching STR0 to STR15	$R_{ILED} = 34.8k\Omega \pm 0.1\%$; $I_{STRn} = 0x20$; $V_{STRn} = 1V$;			3	%
LED string sink current maximum STR0 to STR15	$R_{ILED} = 20.5k\Omega$; $I_{STRn} = 0x3F$ (Note 8, Note 9, Note 10)		100		mA
Short circuit fault detection threshold	$T_A = +25^{\circ}C$	2.5	3.5	4.5	V
Thermal cutoff temperature	(Note 10)		135		$^{\circ}C$
Input leakage				10	μA

PARAMETER	CONDITIONS AND NOTES	MIN	TYP	MAX	UNIT
AC ELECTRICAL CHARACTERISTICS					
OSC initial accuracy	OSCTRL = 0x04 ($f_{OSC} = 20MHz$); $T_A = 25^{\circ}C$	18	20	22	MHz
PHI frequency		40		10000	Hz

Atmel LED Driver-MSL3162

16-string, RGB and White LED Drivers with Adaptive Power Control and 1MHz I²C/SMBus Serial Interface

PARAMETER	CONDITIONS AND NOTES	MIN	TYP	MAX	UNIT
GSC frequency		0		5	MHz
High and low time PHI, GSC		40			ns
PWM frequency		20		50000	Hz
PWM duty cycle		0.5		100	%
PHI DLL lock cycles	(Note 10)		4		PHI cycles

PARAMETER	SYMBOL	CONDITIONS AND NOTES	MIN	TYP	MAX	UNIT
I²C SWITCHING CHARACTERISTICS						
SCL clock frequency	1/t _{SCL}	Bus timeout disabled (Note 2)	0		1000	kHz
Bus timeout period	t _{TIMEOUT}	OSCTRL = 0x04 (f _{OSC} =20MHz); T _A =25°C	27	30	33	ms
		OSCTRL = 0x00 to 0x07; f _{OSC} =16 to 23MHz	600000 / f _{OSC}			
STOP to START condition bus free time	t _{BUF}		0.5			µs
Repeated START condition hold time	t _{HD:STA}		0.26			µs
Repeated START condition setup time	t _{SU:STA}		0.26			µs
STOP condition setup time	t _{SU:STOP}		0.26			µs
SDA data hold time	t _{HD:DAT}		5			ns
SDA data valid acknowledge time	t _{VD:ACK}	(Note 3)	0.05		0.55	µs
SDA data valid time	t _{VD:DAT}	(Note 4)	0.05		0.55	µs
SDA data set-up time	t _{SU:DAT}		100			ns
SCL clock low period	t _{LOW}		0.5			µs
SCL clock high period	t _{HIGH}		0.26			µs
SDA, SCL fall time	t _F	(Note 5, Note 6)			120	ns
SDA, SCL rise time	t _R				120	ns
SDA, SCL input suppression filter period	t _{SP}	(Note 7, Note 10)		50		ns

Note 1. All parameters are tested at T_A=25°C unless otherwise noted. Specifications at temperature are guaranteed by design

Note 2. Minimum SCL clock frequency is limited by the bus timeout feature, which resets the serial bus interface if either SDA or SCL is held low for t_{TIMEOUT}. Disable bus timeout feature for DC operation

Note 3. t_{VD:ACK} = SCL low to SDA (out) low acknowledge time

Note 4. t_{VD:DAT} = minimum SDA output data-valid time following SCL low transition

Note 5. A master device must internally provide an SDA hold time of at least 300ns to ensure an SCL low state

Note 6. The maximum SDA and SCL rise times are 300ns. The maximum SDA fall time is 250ns. This allows series protection resistors to be connected between SDA and SCL inputs and the SDA/SCL bus lines without exceeding the maximum allowable rise time

Note 7. MSL3162 includes input filters on SDA, SCL, ADO, and AD1 inputs that suppress noise less than 50ns

Note 8. Subject to thermal dissipation characteristics of the device

Note 9. When mounted according to JEDEC, JEP149, and JESD51-12 for a two-layer PCB, θ_{JA} = 18.6°C/W and θ_{JC} = 1.4°C/W

Note 10. Guaranteed by design and characterization. Not production tested



Block Diagram

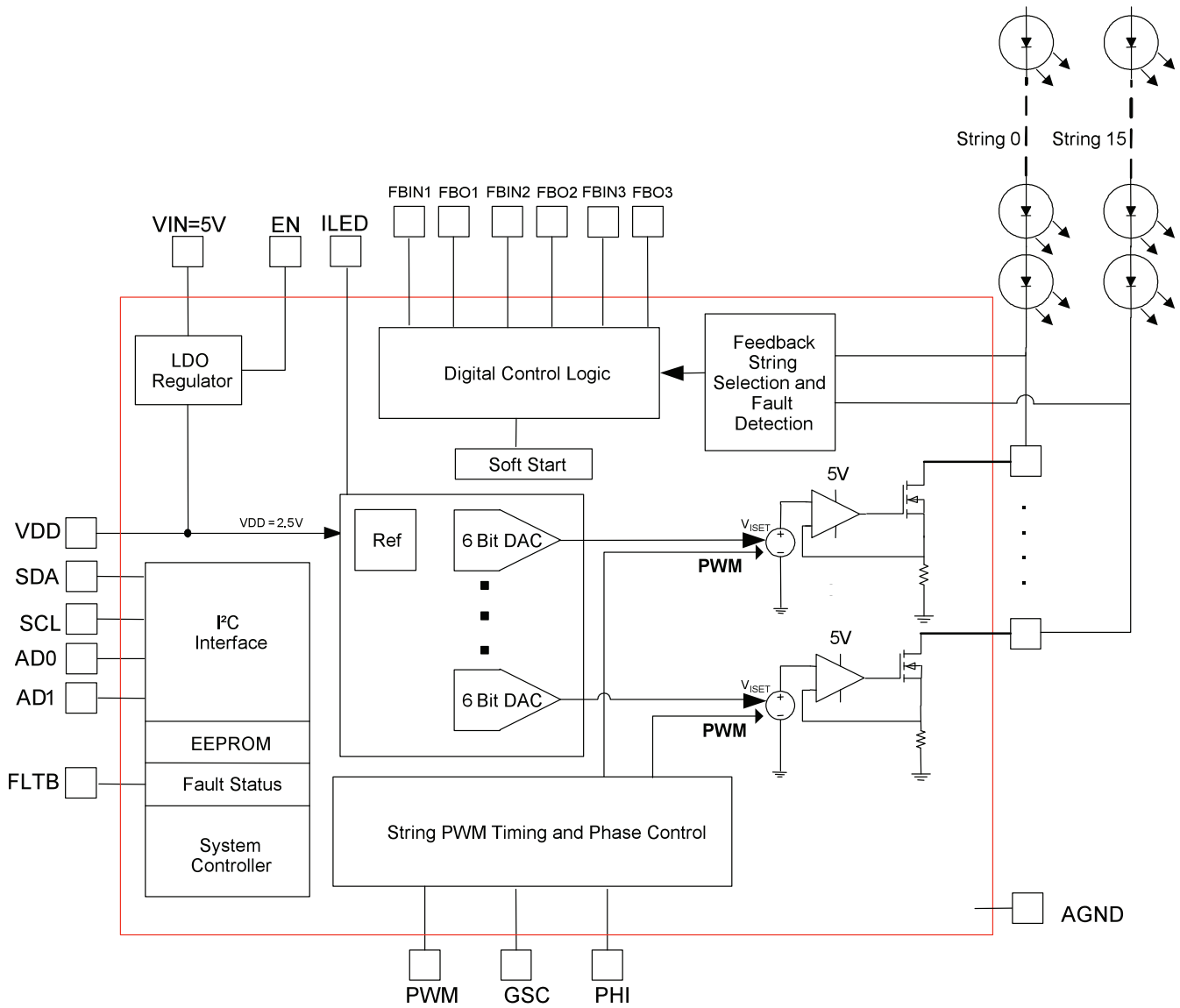

Figure 3. Atmel LED Driver-MSL3162 Block Diagram

Atmel LED Driver-MSL3162

16-string, RGB and White LED Drivers with Adaptive Power Control and 1MHz I²C/SMBus Serial Interface

Typical Application Circuit

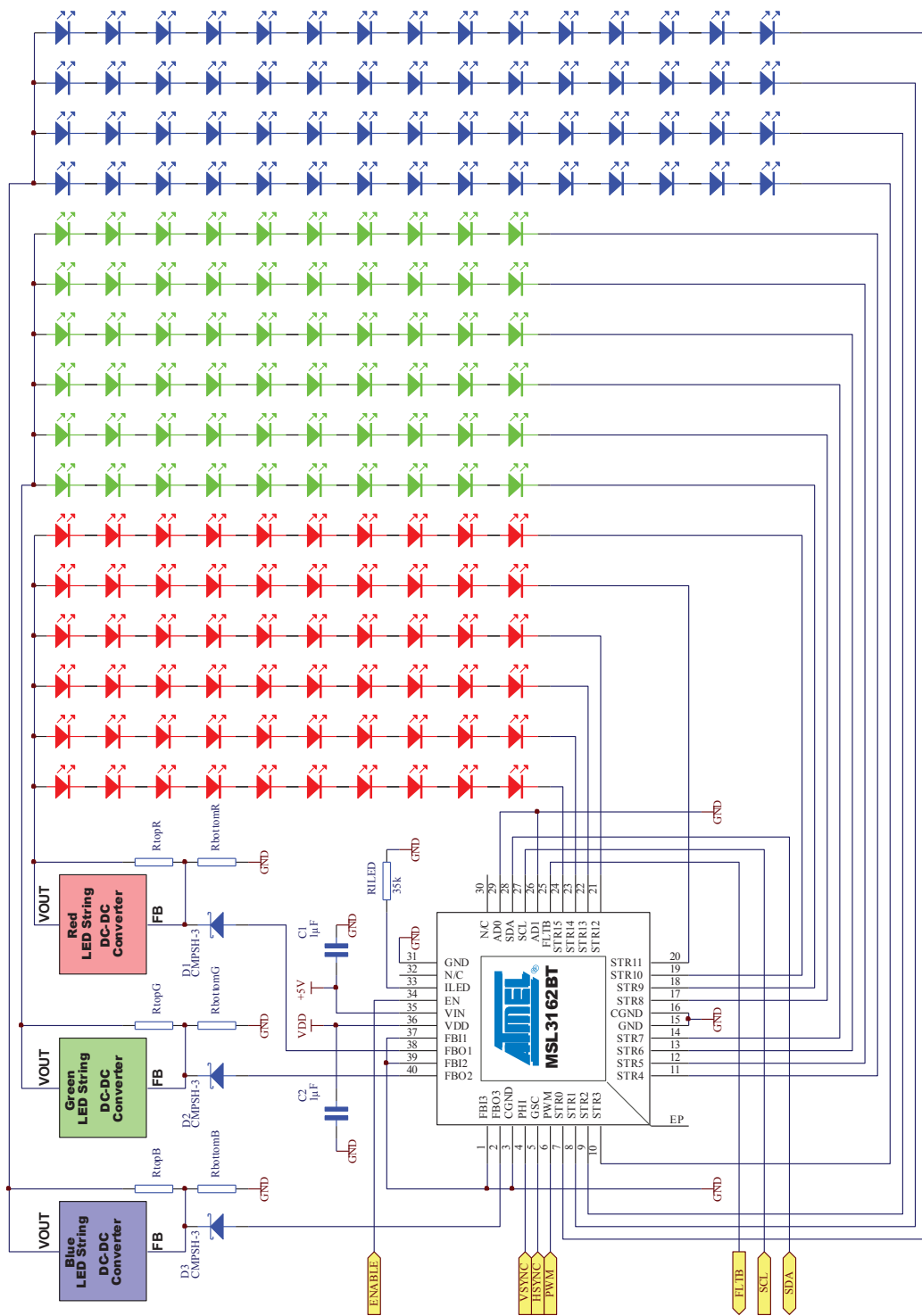

Figure 4. Single Atmel LED Driver-MSL3162 Driving 60 Red, 60 Green, and 60 Blue LED Strings at 60mA Per String



Detailed Description

Internal Regulators and Enable Input

Built-in current control MOSFETs capable of withstanding up to 40V provide a compact solution. The Efficiency Optimizer circuit controls the LED voltage generated by an external DC-DC converter to minimize losses on the current control MOSFETs, improving efficiency and reducing driver power dissipation. The MSL3162 uses a high-speed, 1MHz I²C serial interface to control LED current, PWM dimming, and fault detection circuitry, making it an optimal solution for driving LED backlights for LCD panels. Onboard EEPROM allows default settings to be reconfigured for customization and settings to be saved at turn-off, eliminating the need to re-write settings at the next turn-on. The tiny, 6mm x 6mm QFN package enables a compact solution while maintaining high power dissipation.

Internal Regulators and Enable Input

The MSL3162 includes an internal linear regulator that provides 2.5V supply voltage to power internal circuitry. Bypass VDD to GND with a 1μF or greater capacitor as close to the MSL3162 as possible.

The EN input turns the MSL3162 on and off. To turn on the MSL3162, drive EN high with a 5V logic level, and drive EN low to turn it off. When EN is low, the MSL3162 enters low-power mode, reducing input current to 20μA, and turns off the serial interface. For automatic start-up, connect EN to VIN, allowing the MSL3162 to start automatically when voltage is applied.

LED String Current Control

Each MSL3162 includes 16 current sink outputs, rated at 40V, each capable of sinking up to 100mA through a string of series connected LEDs. The internal Efficiency Optimizer circuit controls the LED voltage, minimizing power dissipated in the current sinks while maintaining high current-regulation accuracy. The MSL3162 power dissipation is limited to 2.1W. When using all 16 current sinks, maintain the total power dissipation within power dissipation limits.

Setting the Maximum LED String Current

The maximum I_{I_{LED}} current for the 16 LED strings STR0 to STR15 is set by external resistor R_{I_{LED}} from the ILED pin to GND and is determined by the equation:

$$I_{ILED} = \frac{2050}{R_{ILED}}$$

where I_{I_{LED}} is in mA and R_{I_{LED}} is in kΩ.

R_{I_{LED}} = 34.8kΩ sets the full-scale LED current to 58.9mA. R_{I_{LED}} = 20.5kΩ sets the full-scale LED current to 100mA, the maximum allowed. The currents for the 16 LED strings, STR0 to STR15, are reduced individually from full scale with 6-bit resolution using the LED string current control registers.

If I_{I_{LED}} for the 16 LED strings, STR0 to STR15, is chosen to be 30mA or lower (by selecting the value of external resistor R_{I_{LED}} to be greater than 68.3kΩ), then the values programmed into the LED string current control registers must be limited to the range 0x00 to 0x1F. The full range of 0x00 to 0x3F is only available if I_{I_{LED}} is set to be greater than 30mA by using an R_{I_{LED}} value of 68.3kΩ or lower.

Atmel LED Driver-MSL3162

16-string, RGB and White LED Drivers with Adaptive Power Control and 1MHz I²C/SMBus Serial Interface

Efficiency Optimizer

The Efficiency Optimizer improves power efficiency by adjusting each external LED power supply output voltage to the minimum required by the connected LED strings. It does this by injecting a current from the FBO output into the external LED power source voltage divider (Figure 5), thus lowering the LED supply voltage. The power supply's feedback voltage (internal reference voltage) must be 1.4V or less, and the voltage setting feedback network divider must be accessible. Use a Schottky diode (CMPSH-3 or similar) as shown to protect the power source against reverse current flow into the FBO pin, should the power supply circuit be powered before the MSL3162.

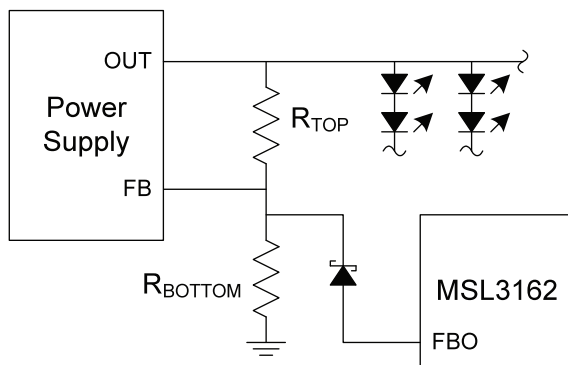

**Figure 5. Atmel LED Driver-MSL3162
FBO_Connection to Power Supply Voltage Divider**

Connecting an LED String Power Supply to an Efficiency Optimizer

An LED string power supply uses a voltage divider (R_{TOP} and R_{BOTTOM} in Figure 6) to set its output voltage. The maximum output voltage is set by the voltage divider ratio and the power supply feedback regulation voltage per the equation:

$$V_{FB} = V_{OUT(MAX)} * \frac{R_{BOTTOM}}{R_{TOP} + R_{BOTTOM}} \quad \text{or} \quad V_{OUT(MAX)} = V_{FB} * \frac{R_{TOP} + R_{BOTTOM}}{R_{BOTTOM}}$$

$V_{OUT(MAX)}$ must exceed the maximum LED string voltage to ensure regulation, but ensure that $V_{OUT(MAX)}$ is always under the 40V maximum rating of the MSL3162's LED string outputs, STR0 to STR15.

The Efficiency Optimizer modifies the feedback network by injecting a current, I_{FBO} , in the range of 0 to 45 μ A from the FBO output into the measurement node, FB. The minimum power supply output voltage is determined by the equation:

$$V_{OUT(MIN)} = V_{OUT(MAX)} - (I_{FBO(MAX)} * R_{TOP})$$

where $I_{FBO(MAX)}$ is the 45 μ A maximum output current from the Efficiency Optimizer output.

From these equations, the equations to calculate the feedback resistors are:

$$R_{TOP} = V_{FB} * \frac{V_{MAX} - V_{MIN}}{I_{FBO(MAX)}} \quad \text{and} \quad R_{BOTTOM} = R_{TOP} * \frac{V_{FB}}{V_{OUT} - V_{FB}}$$



Using Multiple Atmel LED Driver-MSL3162s to Control a Single Power Supply

To use multiple MSL3162s to control a single power supply, connect the FBOx output of one MSL3162 to the FBix input of another MSL3162 to form a chain (Figure 6). The Efficiency Optimizer decides whether the current at the FBix input is less than what the FBOx output is programmed to. If the FBix current is less than the programmed current, the FBix current is transferred to the FBOx output. Otherwise, the programmed current is used at FBOx. The power supply output is, therefore, programmed to the minimum voltage required by all MSL3162s controlling it, and so all LED strings have sufficient voltage to maintain current regulation and power supply noise rejection.

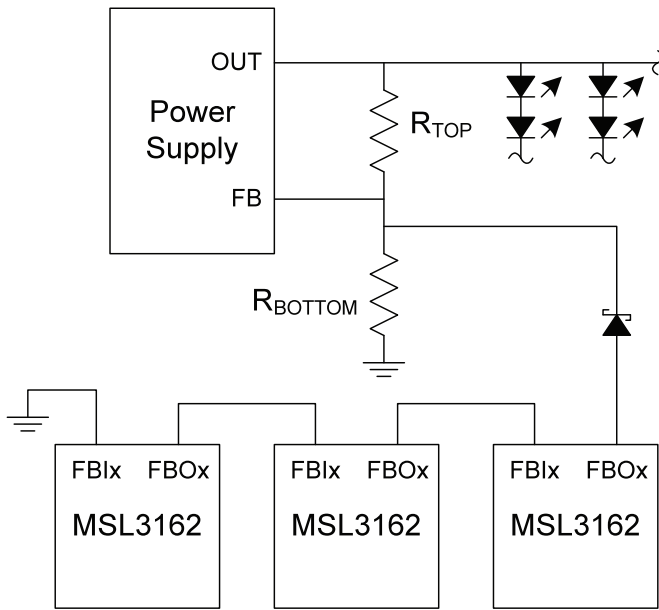

Figure 6. Cascade Multiple Atmel LED Driver-MSL3162s to Control a Common Power Supply

The accuracy of the FBOx output current can degrade through each link of the FBix/FBOx chain by as much as 2%. Therefore, the maximum output voltage correction current can drop by 2% per link. Calculate the worst-case FBOx current by the equation:

$$I_{FBOx (MAX / MIN)} = 45 \mu A * (0.98)^{N-1}$$

where $I_{FBOx (MAX / MIN)}$ is the worst-case (minimum) maximum FBOx output current, and N is the number of MSL3162 FBix/FBOx I/Os connected in series.

Take care in laying out the traces for the Efficiency Optimizer FBix/FBOx I/Os. If the FBix input is not used, connect it to GND as close to the MSL3162 as possible. When routing the FBix/FBOx signals across circuit boards, minimize the trace length as much as possible. Do not route the traces close to other traces with large variations in voltage or current because such traces may couple noise into the FBix/FBOx I/Os. If these traces must be routed near noisy signals, shield them from noise by use of ground planes or guard traces.

Atmel LED Driver-MSL3162

16-string, RGB and White LED Drivers with Adaptive Power Control and 1MHz I²C/SMBus Serial Interface

Register Map Summary

The MSL3162 are controlled through an I²C interface through 82 registers (Table 4). Internal register addressing auto-increments through the register map. In some cases writing to unused register addresses can cause unintended behavior as shown in Table 4. It may be convenient to read or write to unused register address locations when accessing a block of registers sequentially which include unused registers. The power-up default values for all control registers are stored within on-chip user EEPROM, and any of these user EEPROM values may be changed by the user through the I²C interface.

Table 4. Atmel LED Driver-MSL3162 Register Map

REGISTER	ADDRESS	FUNCTION	REGISTER DATA							
			D7	D6	D5	D4	D3	D2	D1	D0
CONTROL0	0x00	LED string enables	STR7EN	STR6EN	STR5EN	STR4EN	STR3EN	STR2EN	STR1EN	STR0EN
CONTROL1	0x01		STR15EN	STR14EN	STR13EN	STR12EN	STR11EN	STR10EN	STR9EN	STR8EN
POWERCTRL	0x02	Fault configuration	SLEEP	-	SCEN	OCEN	0*	TOEN	FBEN	PHAEN
FLTSTATUS	0x03	Fault status, global	0	SCDET	OCDET	0	0	0	FBOICAL	FLTDET
FLTMASK0	0x04	Fault enables, LED string monitoring	FLTEN7	FLTEN6	FLTEN5	FLTEN4	FLTEN3	FLTEN2	FLTEN1	FLTEN0
FLTMASK1	0x05		FLTEN15	FLTEN14	FLTEN13	FLTEN12	FLTEN11	FLTEN10	FLTEN9	FLTEN8
OCSTAT0	0x06	Fault status, LED string open circuit	OC7	OC6	OC5	OC4	OC3	OC2	OC1	OC0
OCSTAT1	0x07		OC15	OC14	OC13	OC12	OC11	OC10	OC9	OC8
SCSTAT0	0x08	Fault status, LED string short circuit	SC7	SC6	SC5	SC4	SC3	SC2	SC1	SC0
SCSTAT1	0x09		SC15	SC14	SC13	SC12	SC11	SC10	SC9	SC8
STRFB0	0x0A	LED string feed-back assignment to power supplies FBO1, FBO2, FBO3	STRFB3[1:0]		STRFB2[1:0]		STRFB1[1:0]		STRFB0[1:0]	
STRFB1	0x0B		STRFB7[1:0]		STRFB6[1:0]		STRFB5[1:0]		STRFB4[1:0]	
STRFB2	0x0C		STRFB11[1:0]		STRFB10[1:0]		STRFB9[1:0]		STRFB8[1:0]	
STRFB3	0x0D		STRFB15[1:0]		STRFB14[1:0]		STRFB13[1:0]		STRFB12[1:0]	
FBOCTRL0	0x10		Efficiency Optimizer configuration	HLDSTEP[1:0]		FBCLDLY[1:0]		FBSDLY[1:0]		FBCFDLY[1:0]
FBOCTRL1	0x11	SCCDLY[1:0]		-	-	ACALPWM	ACALFSTR	ACALEN	TRIDIS	
FBODAC1	0x12	Efficiency Optimizer DAC readback	DSTAT1	0	0	0	FBODAC1[3:0]			
FBODAC2	0x13		DSTAT2	0	0	0	FBODAC2[3:0]			
FBODAC3	0x14		DSTAT3	0	0	0	FBODAC3[3:0]			
OSCCTRL	0x18	Oscillator frequency	-	-	-	-	-	OSC[2:0]		
IGSCGEN	0x1A	GSC clock generator internal	IGSCGEN[7:0]							
	0x1B		IGSCGEN[15:8]							
IPHIGEN	0x1C	PHI clock generator internal	IPHIGEN[7:0]							
	0x1D		IPHIGEN[15:8]							
PWMCTRL0	0x20	PWM and phase control configuration	HPSCREEN	GINTEN	PHIPOL	OTPDIGEN	PHIMINEN	GSCMAXEN	FSNOZSK	1*
PWMCTRL1	0x21		-	-	-	-	-	PWMMODE	INTPHI	INTGSC
SYSTEMP	0x22	System temperature	SYSTEMP[7:0]							
OTTEMP	0x23	Over-temp derating threshold	OTTEMP[7:0]							
OTSLOPE	0x24	Over-temp derating slope	OTSLOPE[7:0]							



Table 4. Atmel LED Driver-MSL3162 Register Map

REGISTER	ADDRESS	FUNCTION	REGISTER DATA							
			D7	D6	D5	D4	D3	D2	D1	D0
GSCMAX	0x25	Max osc. cycles per GSC pulse	GSCMAX[7:0]							
	0x26		GSCMAX[15:8]							
PHIMIN	0x27	Min GSC pulses over PHI period	PHIMIN[7:0]							
	0x28		-	-	-	-	PHIMIN[15:8]			
HPSCR	0x29	GSC divider	-	-	-	-	HPSCR[3:0]			
FRATE	0x2A	PHI freq. multiplier	-	-	-	FRATE[4:0]				
GINT	0x2B	Global intensity	-	-	GINT[6:0]					
ISTR0	0x30	LED string	-	-	ISTR0[5:0]					
		6-bit individual analog current settings	-	-	to					
ISTR15	0x3F		-	-	ISTR15[5:0]					
PHDLY0	0x40	LED string 8-bit individual PWM phase settings	PHDLY0[7:0]							
			to							
PHDLY15	0x4F		PHDLY15[7:0]							
PWM0	0x50	LED string 8-bit individual PWM intensity settings	PWM0[7:0]							
			to							
PWM15	0x5F		PWM15[7:0]							
Do not access address range 0x60 to 0x8F										
E2ADDR	0x90	User EEPROM read/write access	-	E2ADDR[6:0]						
E2CTRLSTA	0x91		E2BUSY	BLDACT	E2ERR	SLVATCNT[1:0]		RWCTRL[1:0]		

- Value written is stored and can be read back, but is not used internally.

* These bits must remain set to the indicated state.

Table 5. Atmel LED Driver-MSL3162 Register Power-up Defaults

REGISTER NAME AND ADDRESS		POWER-UP CONDITION	REGISTER DATA							
			D7	D6	D5	D4	D3	D2	D1	D0
0x00	CONTROL0	LED strings STR0 to STR7 are disabled	1	1	1	1	1	1	1	1
0x01	CONTROL1	LED strings STR8 to STR15 are disabled	1	1	1	1	1	1	1	1
0x02	POWERCTRL	Sleep mode	1	1	1	1	0	1	1	1
0x04	FLTMASK0	Fault detection for LED strings STR0 to STR7 is disabled	1	1	1	1	1	1	1	1
0x05	FLTMASK1	Fault detection for LED strings STR8 to STR15 is disabled	1	1	1	1	1	1	1	1
0x0A to 0x0D	STRFB0 STRFB1 STRFB2 STRFB3	LED strings STR0 to STR7 are not monitored by the voltage optimizers FBO1, FBO2, FBO3	1	1	1	1	1	1	1	1
0x10	FBOCTRL0	Current sink error confirmation delay is 4μs FBO power supply correction delay is 2ms Efficiency Optimizer recalibration delay is 1s Efficiency Optimizer correction steps is 2	0	0	0	0	0	0	0	0
0x11	FBOCTRL1	Auto calibration is disabled	0	0	0	0	0	0	0	0
0x18	OSCCTRL	f_{OSC} is 20MHz	0	0	0	0	0	1	0	0
0x1A	IGSCGEN	$f_{GSC} = f_{OSC}$	0	0	0	0	0	0	0	0
0x1B			0	0	0	0	0	0	0	0
0x1C	IPHIGEN	$f_{PHI} = f_{OSC} / 8$	0	0	0	0	0	0	0	0
0x1D			0	0	0	0	0	0	0	0

Atmel LED Driver-MSL3162

16-string, RGB and White LED Drivers with Adaptive Power Control and 1MHz I²C/SMBus Serial Interface

Table 5. Atmel LED Driver-MSL3162 Register Power-up Defaults

REGISTER NAME AND ADDRESS		POWER-UP CONDITION	REGISTER DATA							
			D7	D6	D5	D4	D3	D2	D1	D0
0x20	PWMCTRL0	PWM is individually controlled by registers PWM0 to PWM15 GSC low- and high-frequency fault detection is disabled Over-temperature derating of LED strings is disabled PHI input falling edge synchronizes LED PWM Global intensity control uses GINT register GSC input is divided by value of GSC prescaler register	1	1	0	0	0	0	0	0
0x21	PWMCTRL1	External GSC signal at GSC input pin is used External PHI signal at PHI input pin is used PWM input pin is unused	0	0	0	0	0	0	0	0
0x22	SYSTEMP	System temperature, SYSTEMP, is 0°C	0	0	0	0	0	0	0	0
0x23	OTTEMP	Temperature compensation threshold, OTCOMP, is 255°C	1	1	1	1	1	1	1	1
0x24	OTSLOPE	Over-temperature derating slope, OTSLOPE, is 0	0	0	0	0	0	0	0	0
0x25	GSCMAX	Maximum GSC pulse count is 65536 (0xFFFF)	1	1	1	1	1	1	1	1
0x26			1	1	1	1	1	1	1	1
0x27	PHIMIN	Minimum PHI pulse count is 0	0	0	0	0	0	0	0	0
0x28			0	0	0	0	0	0	0	0
0x29	HPSCR	Internal GSC clock is GSC input pin frequency	0	0	0	0	0	0	0	0
0x2A	FRATE	PHI multiplier is 1	0	0	0	0	0	0	0	1
0x2B	GINT	Global intensity PWM duty ratio $GINT = 16/64 = 25\%$	0	0	0	0	1	1	1	1
0x30 to 0x3F	ISTR0 to ISTR15	Individual LED string current $I_{LED} = 7/63$ times the full-scale current set by external resistor R_{ILED}	0	0	0	0	0	1	1	1
0x40 to 0x4F	PHDLY0 to PHDLY15	Individual LED string phase delay $t_{DLYx} = 0$	0	0	0	0	0	0	0	0
0x50 to 0x5F	PWM0 to PWM15	Individual LED string PWM duty ratio $D_{PWM} = 1/256 = 0.39\%$	0	0	0	0	0	0	0	0
0x90	E2ADDR	User EEPROM 7-bit address = 0x00	0	0	0	0	0	0	0	0
0x91	E2CTRLSTA	User EEPROM read/write is disabled	0	0	0	0	0	0	0	0

**Atmel Corporation**

2325 Orchard Parkway
San Jose, CA 95131
USA

Tel: (+1)(408) 441-0311

Fax: (+1)(408) 487-2600

www.atmel.com

Atmel Asia Limited

Unit 01-5 & 16, 19F
BEA Tower, Millennium City 5
418 Kwun Tong Road
Kwun Tong, Kowloon
HONG KONG

Tel: (+852) 2245-6100

Fax: (+852) 2722-1369

Atmel Munich GmbH

Business Campus
Parking 4
D-85748 Garching b. Munich
GERMANY

Tel: (+49) 89-31970-0

Fax: (+49) 89-3194621

Atmel Japan

9F, Tonetsu Shinkawa Bldg.
1-24-8 Shinkawa
Chuo-ku, Tokyo 104-0033
JAPAN

Tel: (+81)(3) 3523-3551

Fax: (+81)(3) 3523-7581

© 2011 Atmel Corporation. All rights reserved. / Rev.: MSL3162DB1-E-US_06-11

Atmel®, logo and combinations thereof, and others are registered trademarks or trademarks of Atmel Corporation or its subsidiaries. Other terms and product names may be trademarks of others.

Disclaimer: The information in this document is provided in connection with Atmel products. No license, express or implied, by estoppel or otherwise, to any intellectual property right is granted by this document or in connection with the sale of Atmel products. EXCEPT AS SET FORTH IN THE ATMEL TERMS AND CONDITIONS OF SALES LOCATED ON THE ATMEL WEBSITE, ATMEL ASSUMES NO LIABILITY WHATSOEVER AND DISCLAIMS ANY EXPRESS, IMPLIED OR STATUTORY WARRANTY RELATING TO ITS PRODUCTS INCLUDING, BUT NOT LIMITED TO, THE IMPLIED WARRANTY OF MERCHANTABILITY, FITNESS FOR A PARTICULAR PURPOSE, OR NON-INFRINGEMENT. IN NO EVENT SHALL ATMEL BE LIABLE FOR ANY DIRECT, INDIRECT, CONSEQUENTIAL, PUNITIVE, SPECIAL OR INCIDENTAL DAMAGES (INCLUDING, WITHOUT LIMITATION, DAMAGES FOR LOSS AND PROFITS, BUSINESS INTERRUPTION, OR LOSS OF INFORMATION) ARISING OUT OF THE USE OR INABILITY TO USE THIS DOCUMENT, EVEN IF ATMEL HAS BEEN ADVISED OF THE POSSIBILITY OF SUCH DAMAGES. Atmel makes no representations or warranties with respect to the accuracy or completeness of the contents of this document and reserves the right to make changes to specifications and products descriptions at any time without notice. Atmel does not make any commitment to update the information contained herein. Unless specifically provided otherwise, Atmel products are not suitable for, and shall not be used in, automotive applications. Atmel products are not intended, authorized, or warranted for use as components in applications intended to support or sustain life.



Стандарт Электрон Связь

Мы молодая и активно развивающаяся компания в области поставок электронных компонентов. Мы поставляем электронные компоненты отечественного и импортного производства напрямую от производителей и с крупнейших складов мира.

Благодаря сотрудничеству с мировыми поставщиками мы осуществляем комплексные и плановые поставки широчайшего спектра электронных компонентов.

Собственная эффективная логистика и склад в обеспечивает надежную поставку продукции в точно указанные сроки по всей России.

Мы осуществляем техническую поддержку нашим клиентам и предпродажную проверку качества продукции. На все поставляемые продукты мы предоставляем гарантию .

Осуществляем поставки продукции под контролем ВП МО РФ на предприятия военно-промышленного комплекса России , а также работаем в рамках 275 ФЗ с открытием отдельных счетов в уполномоченном банке. Система менеджмента качества компании соответствует требованиям ГОСТ ISO 9001.

Минимальные сроки поставки, гибкие цены, неограниченный ассортимент и индивидуальный подход к клиентам являются основой для выстраивания долгосрочного и эффективного сотрудничества с предприятиями радиоэлектронной промышленности, предприятиями ВПК и научно-исследовательскими институтами России.

С нами вы становитесь еще успешнее!

Наши контакты:

Телефон: +7 812 627 14 35

Электронная почта: sales@st-electron.ru

Адрес: 198099, Санкт-Петербург,
Промышленная ул, дом № 19, литера Н,
помещение 100-Н Офис 331