

DESCRIPTION

Introduction

Demonstration circuit 2159 provides USB connectivity to an FMC compatible FPGA evaluation board via an FT2232H Dual USB UART/FIFO. It is used in conjunction with various FPGA boards and a Linear Technology data converter evaluation board as part of an evaluation system for Linear Technology products.

Design files for this circuit board are available at <http://www.linear.com/demo/DC2159A>

LT, LT, LTC, LTM, Linear Technology and the Linear logo are registered trademarks of Linear Technology Corporation. All other trademarks are the property of their respective owners.

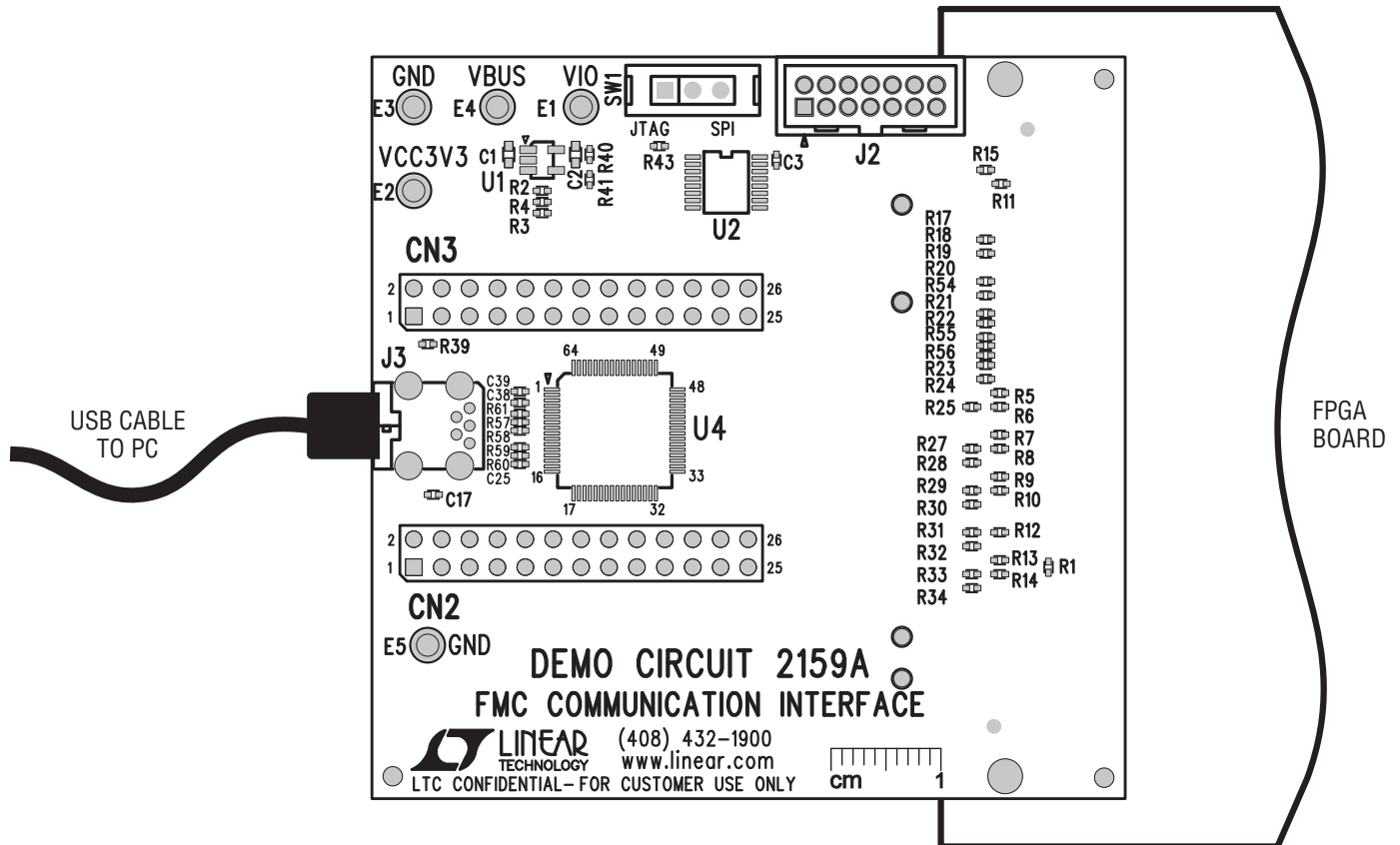

Figure 1. Basic Connections

DEMO MANUAL DC2159A

QUICK START PROCEDURE

Make sure FPGA board power is OFF and no USB cable is connected. Seat the FMC connector on the back side of DC2159 to the mating connector on the FPGA board, pressing evenly across the connector and providing support on the back side of the FPGA board. Install two 4-40 nuts on the two standoffs to secure the connection. Verify that SW1 is in the SPI position.

Follow any additional setup instructions for the data converter board (For example, DC1974 shown in Figure 2.)

Only insert the USB cable AFTER the FPGA board is powered up. (The FT2232 I/O power is only enabled when the

FPGA board is powered up; inserting the USB cable without I/O power causes incorrect identification of the FT2232.)

JTAG Port

J2 provides a JTAG connection that may be used in some evaluation setups. Refer to the data converter's demo manual.

Other Connections

All test points are for factory use only. Do not make any other connections.

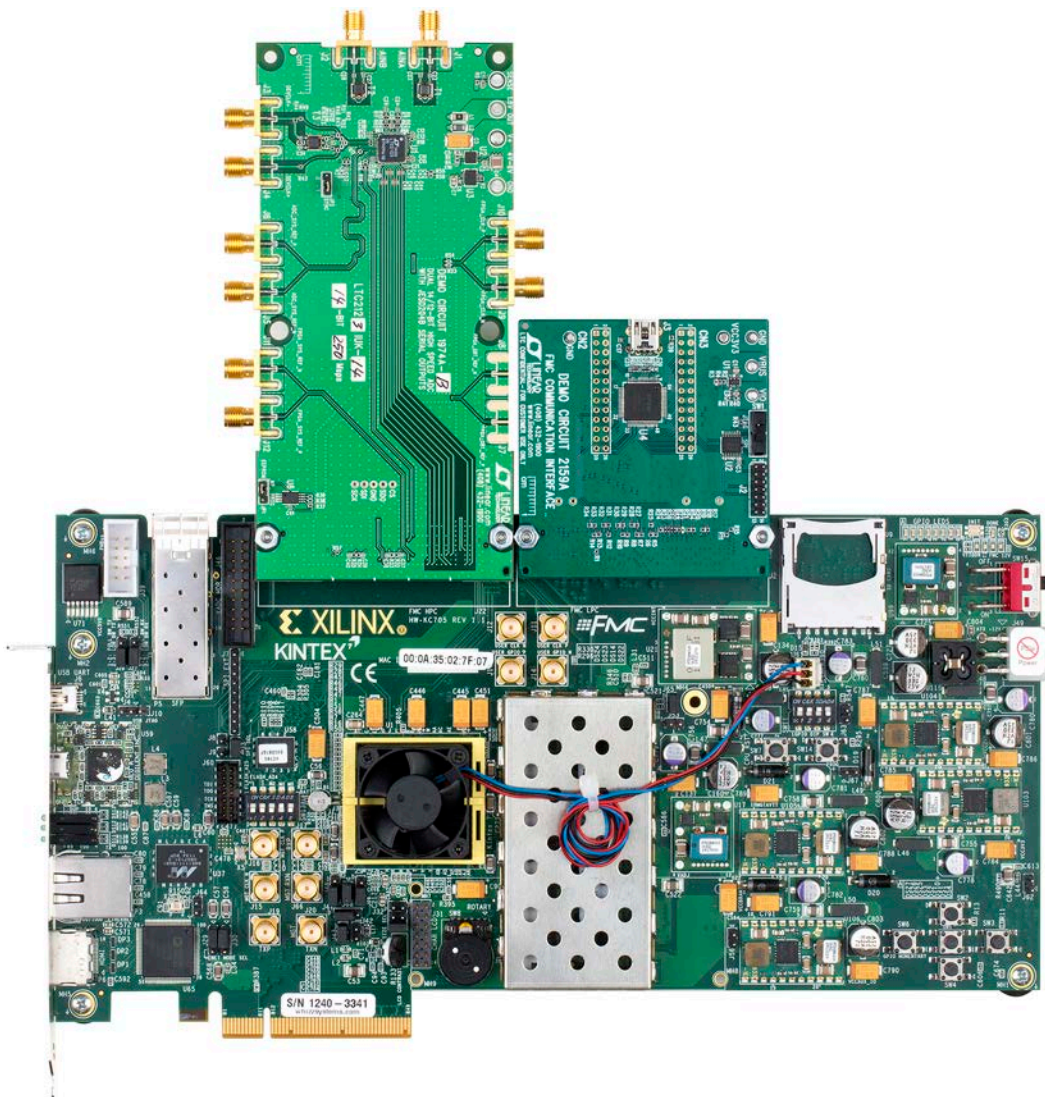

Figure 2. Complete LTC2123 Demonstration System (DC2159, DC1974, and Xilinx KC705 Board)

dc2159af

PARTS LIST

ITEM	QTY	REFERENCE	PART DESCRIPTION	MANUFACTURER/PART NUMBER
Required Circuit Components				
1	0	CN2, CN3	SOCKET, 2X13-100, HD2X13-100	SAMTEC, BCS-113-L-D-TE
2	2	C1, C2	CAP., X5R, 10µF 6.3V, 20%, 0603	AVX, 06036D106MAT2A
3	13	C3, C5-C14, C24, C25	CAP., X7R, 0.1µF, 10V, 10%, 0402	AVX, 0402ZC104KAT2A
4	5	C4, C15, C19, C20, C21	CAP., X5R, 4.7µF, 6.3V, 20%, 0402	MURATA, GRM155R60J475ME87D
5	5	C16, C17, C18, C22, C23	CAP., X7R, 0.01µF, 10V, 10%, 0402	AVX, 0402ZC103KAT2A
6	2	C38, C39	CAP., COG, 27pF, 50V 5% 0402	TDK, C1005C0G1H270J
7	0	E1, E2, E3, E4, E5	TP, TURRET, 0.064"	MILL-MAX, 2308-2-00-80-00-00-07-0
8	3	FB1, FB2, FB3	FERRITE BEAD, 600Ω AT 100MHz, 0603	MURATA, BLM18HG601SN1D
9	1	J1	BGA CONNECTOR, 40X10	SAMTEC, SEAM-40-02.0-S-10-2-A-K-TR
10	1	J2	HEADER, 2X7, 0.079", HD2X7-79	SULLINS, NRPN072PAEN-RC
11	1	J3	CONN., MINI USB 2.0 TYPE B, RIGHT ANGLE	WE, 651005136521
12	33	R1, R2, R5-R24, R26-R34, R55, R56	RES., CHIP, 49.9Ω, 1/16W, 1%, 0402	YAGEO, RC0402FR-0749R9L
13	0	R3	RES., 0402	OPT
14	4	R4, R41, R60, R62	RES., CHIP, 10k, 1/16W, 5%, 0402	YAGEO, RC0402JR-0710KL
15	7	R25, R35-R39, R64	RES., CHIP, 0Ω, 0402	YAGEO, RC0402JR-070RL
16	1	R40	RES., CHIP, 14.3k, 1/16W, 1% 0402	YAGEO, RC0402FR-0714K3L
17	12	R42-R53	RES., CHIP, 1k, 1/16W, 5%, 0402	YAGEO, RC0402JR-071KL
18	0	R54	RES., 0402	OPT
19	2	R57, R58	RES., CHIP, 10Ω, 1/16W, 5%, 0402	YAGEO, RC0402JR-0710RL
20	1	R59	RES., CHIP, 15k, 1/16W, 5%, 0402	YAGEO, RC0402JR-0715KL
21	1	R61	RES., CHIP, 12k, 1/16W, 5%, 0402	YAGEO, RC0402JR-0712KL
22	1	R63	RES., CHIP, 2k, 1/16W, 5%, 0402	YAGEO, RC0402JR-072KL
23	1	SW1	SWITCH, SLIDE SPDT 30V 0.2A, THROUGH HOLE	E-SWITCH, EG1218
24	1	U1	I.C., LT1761ES5-SD, TSOT23-5	LINEAR TECH., LT1761ES5-SD
25	1	U2	I.C., QUAD 2:1 SWITCH, TSSOP16	FAIRCHILD SEMI., FST3257MTCX
26	1	U3	I.C., EEPROM 1KBIT 3MHz, TSSOP8	MICROCHIP, 93LC46C-I/ST
27	1	U4	I.C., DUAL HIGH SPEED USB, LQFP64	FTDI, FT2232HL-1000
28	1	U5	I.C., LT1761ES5-3.3, TSOT23-5	LINEAR TECH., LT1761ES5-3.3
29	1	Y1	CRYSTAL, 12.0MHz, SMT	ABRACON, ABMM2-12.000MHZ-E2-T

SCHEMATIC DIAGRAM

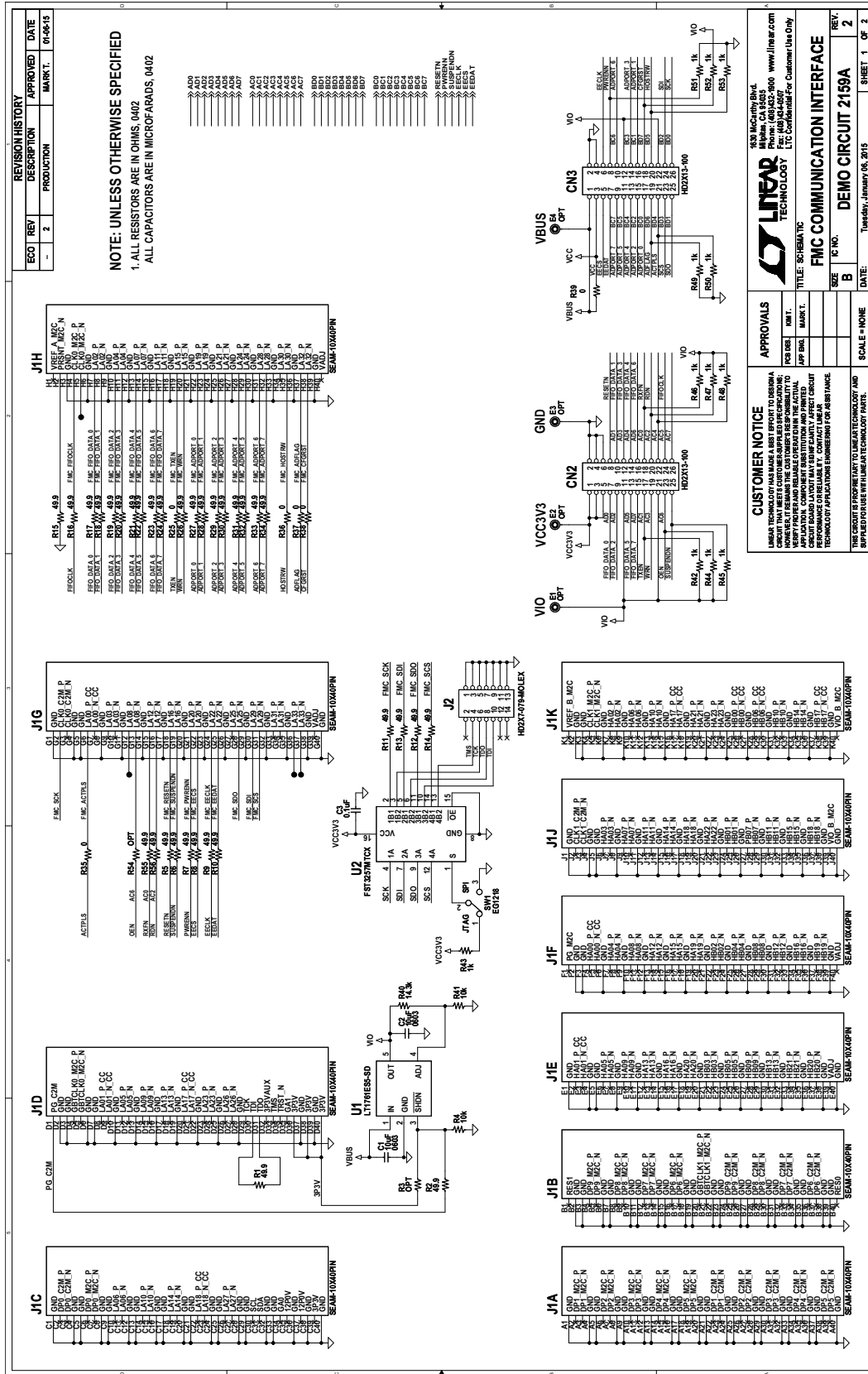

SCHEMATIC DIAGRAM

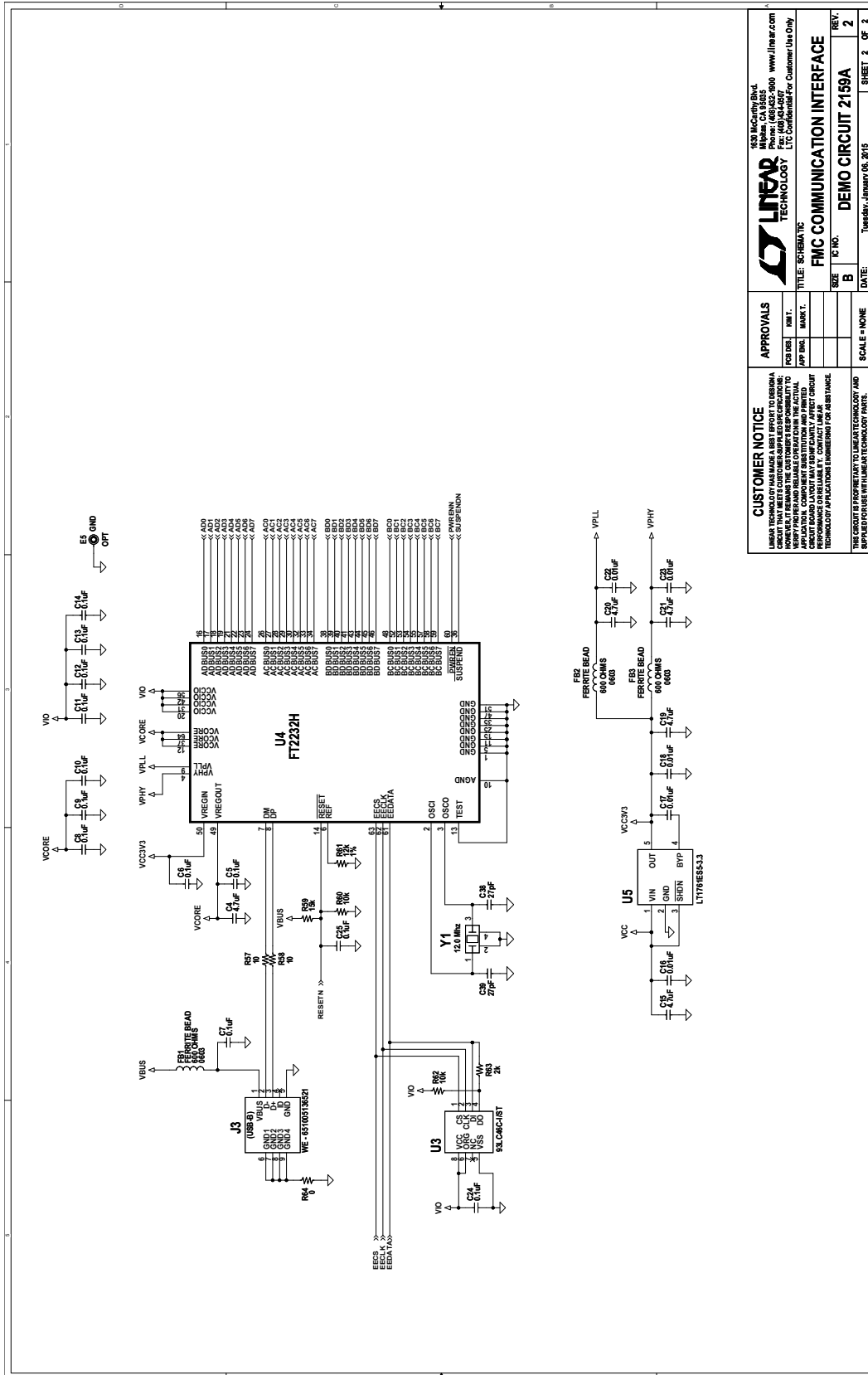

CUSTOMER NOTICE		APPROVALS	
LINEAR TECHNOLOGY HAS MADE A BEST EFFORT TO DESIGN A CIRCUIT THAT MEETS CUSTOMER-SUPPLIED SPECIFICATIONS. WE DO NOT WARRANT THE PERFORMANCE OF ANY COMPONENTS IN THIS CIRCUIT. WE DO NOT WARRANT THE RELIABILITY OF THE ACTUAL APPLICATION. COMPONENT SUBSTITUTION AND PRINTED CIRCUIT BOARD MANUFACTURING VARIATIONS MAY AFFECT PERFORMANCE OR RELIABILITY. CONTACT LINEAR TECHNOLOGY APPLICATION ENGINEERING FOR ASSISTANCE.		DESIGNED BY: _____	DATE: _____
THIS CIRCUIT IS PROVIDED AS A DESIGN EXAMPLE ONLY. IT IS NOT INTENDED FOR PRODUCTION OR FOR USE IN LIFE-SUPPORT AND OTHER HIGHLY RELIABLE APPLICATIONS WITHOUT THE EXPRESS WRITTEN APPROVAL OF LINEAR TECHNOLOGY.		APP'D BY: _____	SCALE: NONE
		MARKT: _____	REV: _____
		SIZE: _____	2
		IC NO.: _____	2
		DATE: _____	2
		TITLE: SCHEMATIC	SHEET 2 OF 2
		DEMO CIRCUIT 2159A	
		FMC COMMUNICATION INTERFACE	
		LINEAR TECHNOLOGY	
		1630 Broadway Blvd.,	
		Folsom, CA 95630	
		Phone: (916) 961-5000	
		Fax: (916) 961-5007	
		www.linear.com	
		LTC Confidential For Customer Use Only	



Information furnished by Linear Technology Corporation is believed to be accurate and reliable. However, no responsibility is assumed for its use. Linear Technology Corporation makes no representation that the interconnection of its circuits as described herein will not infringe on existing patent rights.

DEMO MANUAL DC2159A

DEMONSTRATION BOARD IMPORTANT NOTICE

Linear Technology Corporation (LTC) provides the enclosed product(s) under the following **AS IS** conditions:

This demonstration board (DEMO BOARD) kit being sold or provided by Linear Technology is intended for use for **ENGINEERING DEVELOPMENT OR EVALUATION PURPOSES ONLY** and is not provided by LTC for commercial use. As such, the DEMO BOARD herein may not be complete in terms of required design-, marketing-, and/or manufacturing-related protective considerations, including but not limited to product safety measures typically found in finished commercial goods. As a prototype, this product does not fall within the scope of the European Union directive on electromagnetic compatibility and therefore may or may not meet the technical requirements of the directive, or other regulations.

If this evaluation kit does not meet the specifications recited in the DEMO BOARD manual the kit may be returned within 30 days from the date of delivery for a full refund. **THE FOREGOING WARRANTY IS THE EXCLUSIVE WARRANTY MADE BY THE SELLER TO BUYER AND IS IN LIEU OF ALL OTHER WARRANTIES, EXPRESSED, IMPLIED, OR STATUTORY, INCLUDING ANY WARRANTY OF MERCHANTABILITY OR FITNESS FOR ANY PARTICULAR PURPOSE. EXCEPT TO THE EXTENT OF THIS INDEMNITY, NEITHER PARTY SHALL BE LIABLE TO THE OTHER FOR ANY INDIRECT, SPECIAL, INCIDENTAL, OR CONSEQUENTIAL DAMAGES.**

The user assumes all responsibility and liability for proper and safe handling of the goods. Further, the user releases LTC from all claims arising from the handling or use of the goods. Due to the open construction of the product, it is the user's responsibility to take any and all appropriate precautions with regard to electrostatic discharge. Also be aware that the products herein may not be regulatory compliant or agency certified (FCC, UL, CE, etc.).

No License is granted under any patent right or other intellectual property whatsoever. **LTC assumes no liability for applications assistance, customer product design, software performance, or infringement of patents or any other intellectual property rights of any kind.**

LTC currently services a variety of customers for products around the world, and therefore this transaction **is not exclusive**.

Please read the DEMO BOARD manual prior to handling the product. Persons handling this product must have electronics training and observe good laboratory practice standards. **Common sense is encouraged.**

This notice contains important safety information about temperatures and voltages. For further safety concerns, please contact a LTC application engineer.

Mailing Address:

Linear Technology
1630 McCarthy Blvd.
Milpitas, CA 95035

Copyright © 2004, Linear Technology Corporation



Стандарт Электрон Связь

Мы молодая и активно развивающаяся компания в области поставок электронных компонентов. Мы поставляем электронные компоненты отечественного и импортного производства напрямую от производителей и с крупнейших складов мира.

Благодаря сотрудничеству с мировыми поставщиками мы осуществляем комплексные и плановые поставки широчайшего спектра электронных компонентов.

Собственная эффективная логистика и склад в обеспечивает надежную поставку продукции в точно указанные сроки по всей России.

Мы осуществляем техническую поддержку нашим клиентам и предпродажную проверку качества продукции. На все поставляемые продукты мы предоставляем гарантию .

Осуществляем поставки продукции под контролем ВП МО РФ на предприятия военно-промышленного комплекса России , а также работаем в рамках 275 ФЗ с открытием отдельных счетов в уполномоченном банке. Система менеджмента качества компании соответствует требованиям ГОСТ ISO 9001.

Минимальные сроки поставки, гибкие цены, неограниченный ассортимент и индивидуальный подход к клиентам являются основой для выстраивания долгосрочного и эффективного сотрудничества с предприятиями радиоэлектронной промышленности, предприятиями ВПК и научно-исследовательскими институтами России.

С нами вы становитесь еще успешнее!

Наши контакты:

Телефон: +7 812 627 14 35

Электронная почта: sales@st-electron.ru

Адрес: 198099, Санкт-Петербург,
Промышленная ул, дом № 19, литера Н,
помещение 100-Н Офис 331