

Devices Connected/Referenced

AD8226	Wide Supply Range, Rail-to-Rail Output Instrumentation Amplifier
ADR02	Ultracompact, Precision 5.0 V Voltage Reference
ADA4091-4	Precision Micropower, OVP, RRIO Operational Amplifier

Flexible, 4 mA-to-20 mA Pressure Sensor Transmitter with Voltage or Current Drive

EVALUATION AND DESIGN SUPPORT

Circuit Evaluation Boards

[CN0295 Evaluation Board \(EVAL-CN0295-EB1Z\)](#)

Design and Integration Files

[Schematics, Layout Files, Bill of Materials](#)

CIRCUIT FUNCTION AND BENEFITS

The circuit shown in Figure 1 is a flexible current transmitter that converts the differential voltage output from a pressure sensor to a 4 mA-to-20 mA current output.

The circuit is optimized for a wide variety of bridge-based voltage or current driven pressure sensors, utilizes only five active devices, and has a total unadjusted error of less than 1%. The power supply voltage can range from 7 V to 36 V depending on the component and sensor driver configuration.

The input of the circuit is protected for ESD and voltages beyond the supply rail, making it ideal for industrial applications.

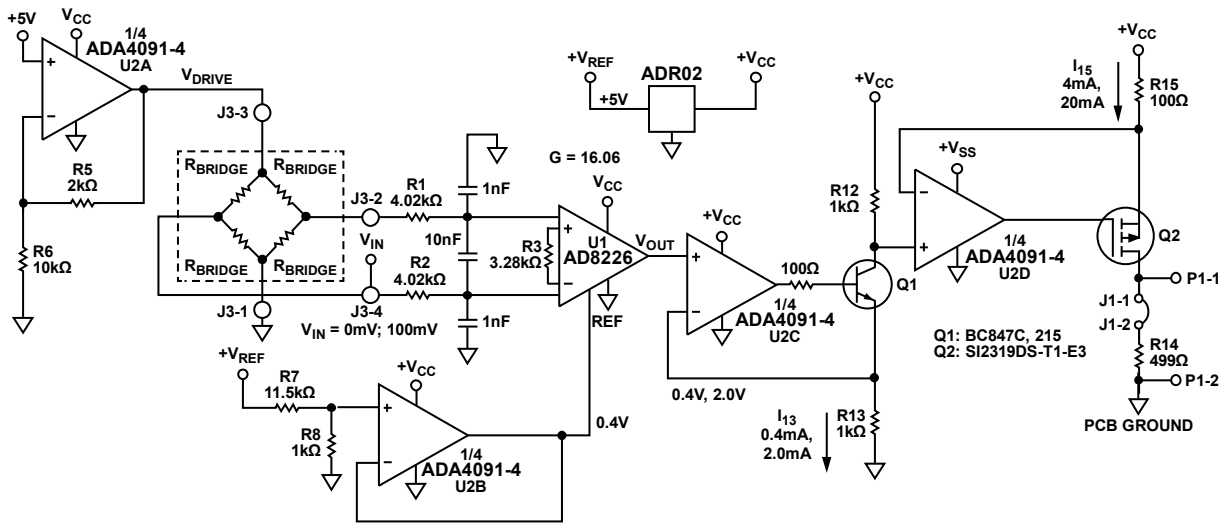

Figure 1. Pressure Sensor Signal Conditioning Circuit with 4 mA-to-20 mA Output (Shown in Sensor Voltage Drive Mode) (Simplified Schematic: All Connections and Decoupling Not Shown)

11610-001

Rev.0

Circuits from the Lab™ circuits from Analog Devices have been designed and built by Analog Devices engineers. Standard engineering practices have been employed in the design and construction of each circuit, and their function and performance have been tested and verified in a lab environment at room temperature. However, you are solely responsible for testing the circuit and determining its suitability and applicability for your use and application. Accordingly, in no event shall Analog Devices be liable for direct, indirect, special, incidental, consequential or punitive damages due to any cause whatsoever connected to the use of any Circuits from the Lab circuits. (Continued on last page)

CIRCUIT DESCRIPTION

The design provides a complete solution for the 4 mA-to-20 mA transmitter for pressure sensor measurements. The circuit has three critical stages: the sensor excitation drive, the sensor output amplifier, and the voltage to current converter.

The total current required by the circuit (neglecting the bridge drive current and the output current) is 5.23 mA (maximum) as shown in Table 1.

Table 1. Maximum circuit currents at 25°C

Component	Current (mA)
ADR02	0.80
ADA4091-4	1.00
AD8226	0.43
R5, R6 at 6 V	0.60
R7, R8 at 5 V	0.40
R13 at 2 V	2.00
Total	5.23

Excitation: Voltage Drive Configuration

Depending on the pressure sensor selected, either a voltage or current drive is required. The circuit uses one-fourth of the ADA4091-4 (U2A) with different configurations chosen by switching S1 to support either option. Figure 2 shows the

configuration for the voltage drive with S1 in the position closest to the identifying marking (see complete circuit layouts and schematics in the CN0295 design support package: <http://www.analog.com/CN0295-DesignSupport>). The voltage drive is normally configured for a bridge drive voltage of 6 V by the gain of the stage, $1 + R5/R6$. Other drive voltages can be obtained by changing the resistor ratio appropriately:

$$V_{DRIVE} = 5 V \left(1 + \frac{R5}{R6} \right)$$

Note that the power supply voltage V_{CC} should be at least 0.2 V greater than the bridge drive voltage to allow sufficient headroom for U2A, the ADA4091-4:

$$V_{CC} \geq V_{DRIVE} + 0.2 V$$

For the values shown in Figure 2, $R5 = 2 \text{ k}\Omega$, $R6 = 10 \text{ k}\Omega$, $I_{DRIVE} = 2 \text{ mA}$, $V_{DRIVE} = 6 \text{ V}$, and $V_{CC} \geq 6.2 \text{ V}$.

The ADA4091-4 op amp is chosen for the circuit because of its low current consumption (250 μA /amplifier), low offset voltage (250 μV), and rail-to-rail inputs and outputs.

The ADR02 is chosen for the 5 V reference because of its accuracy (A-Grade: 0.1%, B-Grade: 0.06%) and low quiescent current (0.8 mA).

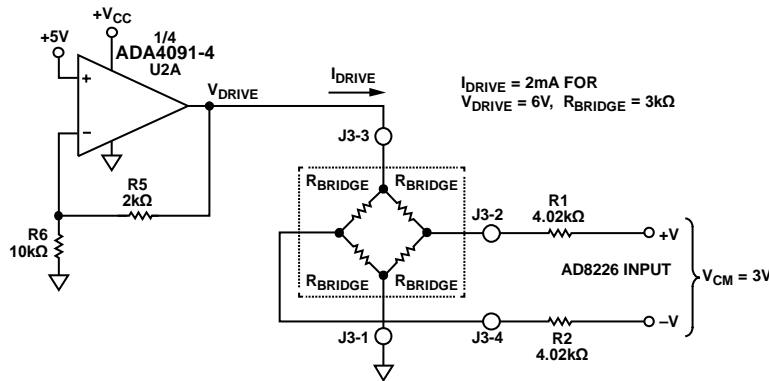

Figure 2. Sensor Voltage Drive Configuration (Simplified Schematic: All Connections and Decoupling Not Shown)

Excitation: Current Drive Configuration

The circuit can be switched to the current drive configuration shown in Figure 3 by moving S1 to the position that is furthest away from the identifying marking.

In the current drive mode, the circuit is configured for $R4 = 2.5\text{ k}\Omega$, and $I_{DRIVE} = 2\text{ mA}$. Lower or higher values of I_{DRIVE} can be obtained by using the following equation to select the value of $R4$:

$$R4 = \frac{5\text{ V}}{I_{DRIVE}}$$

The resulting drive voltage V_{DRIVE} is calculated from:

$$V_{DRIVE} = 5\text{ V} + I_{DRIVE} \times R_{BRIDGE}$$

A headroom of 0.2 V is required for the V_{CC} supply, therefore:

$$V_{CC} \geq V_{DRIVE} + 0.2\text{ V}$$

For the values shown in Figure 3, $R_{BRIDGE} = 3\text{ k}\Omega$, $I_{DRIVE} = 2\text{ mA}$, $V_{DRIVE} = 11\text{ V}$, and $V_{CC} \geq 11.2\text{ V}$.

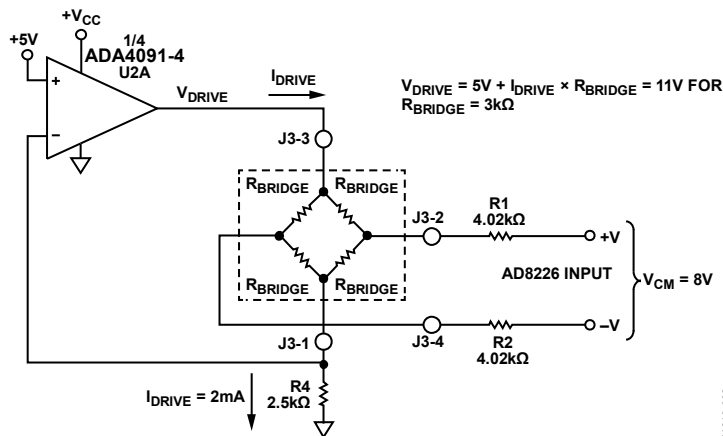

Figure 3. Sensor Current Drive Configuration (Simplified Schematic: All Connections and Decoupling Not Shown)

Bridge Output Instrumentation Amplifier and Offset Circuit

The output of the bridge is filtered by a common-mode filter (4.02 k Ω , 1 nF) with a bandwidth of 39.6 kHz and a differential-mode filter (8.04 k Ω , 10 nF) with a bandwidth of 1.98 kHz.

The [AD8226](#) is an ideal choice for the in-amp because of its low gain error (0.1%, B-grade), low offset (58 μ V at G = 16, B-grade; 112 μ V at G = 16, A-grade), excellent gain nonlinearity (75 ppm = 0.0075%), and rail-to-rail inputs and output.

The [AD8226](#) instrumentation amplifier amplifies the 100 mV FS signal by a factor of 16 to 1.6 V using a gain setting resistor R3 = 3.28 k Ω . The relationship between the gain, G, and R3 is given by

$$R3 = \frac{49.4 \text{ k}\Omega}{G - 1}$$

For G = 16, R3 = 3.2933 k Ω . The nearest standard 0.05% value of 3.28 k Ω is chosen for R3, yielding a gain of G = 16.06, which introduces an overall gain error of +0.4%.

For a 0 V bridge output, the output loop current should be 4 mA. This is achieved by simply applying a +0.4 V offset to the REF input of the [AD8226](#) in amp as shown in Figure 1. The +0.4 V is derived from the [ADR02](#) 5 V reference using divider resistors R7/R8 and buffering the voltage with U2B.

The [ADR02](#) 5 V reference is used to set the drive voltage or current to the bridge and to set the 4 mA zero offset. It has an initial accuracy of 0.06% (B-grade) and 10 μ V p-p voltage noise. In addition, it operates on supply voltages up to 36 V and consumes less than 1 mA, making it an ideal choice for low power applications.

Voltage to Current Conversion

The 0 V to 100 mV input to the [AD8226](#) generates an output swing at V_{OUT} of 0.4 V to 2.0 V. The buffer, U2C, applies this voltage across R13 that produces a corresponding current I₁₃ of 0.4 mA to 2.0 mA. Transistor Q1 then mirrors the I₁₃ current to R12, and the resulting voltage is applied to R15, thereby developing the final loop current of 4 mA to 20 mA. Transistor Q1 should have a high gain of at least 300 to minimize the linearity error due to its base current.

The output transistor Q2 is a 40 V P-channel MOSFET power transistor capable of dissipating 0.75 W at 25°C. The worst-case power dissipation in the circuit is for an output current of 20 mA into a loop load resistance of 0 Ω with a V_{CC} supply of 36 V. Under these conditions the power dissipation of Q2 is 0.68 W. However, the power in Q2 can be significantly reduced by properly selecting V_{CC} so that it is at least 3 V greater than the maximum loop load voltage. This ensures sufficient headroom due to the voltage dropped across the sense resistor R15.

Voltage Supply Requirement

In order for the circuit to operate properly, the supply voltage, V_{CC}, must be greater than 7 V in order to provide sufficient headroom for the [ADR02](#) voltage reference.

The minimum V_{CC} supply voltage is also dependent on the configuration of the drive circuit for the bridge. In the voltage drive mode with V_{DRIVE} = 6 V, the supply voltage V_{CC} must be greater than 6.2 V in order to maintain sufficient headroom for U2A (see Figure 2).

In the current drive mode, the supply voltage V_{CC} must be greater than 11.2 V in order to maintain sufficient headroom for U2A (see Figure 3).

The V_{CC} supply voltage is limited to 36 V maximum.

Error Analysis for Active Components

The maximum and rss errors due to the active components in the system for A- and B-grade levels of the [AD8226](#) and the [ADR02](#) are shown in Tables 2 and 3. Note that the [ADA4091-2](#) op amp is only available in one grade level.

Table 2. Errors Due to Active Components (A-Grade)

Error Component	Error	Error Value	Error %FSR
AD8226-A	Offset	112 μ V	0.11%
ADR02-A	Offset	0.10%	0.02%
ADA4091-4 (U2B)	Offset	250 μ V	0.02%
ADA4091-4 (U2C)	Offset	250 μ V	0.02%
ADA4091-4 (U2D)	Offset	250 μ V	0.02%
AD8226-A	Gain	0.15%	0.15%
RSS Offset			0.12%
RSS Gain			0.15%
RSS FS Error			0.27%
Max Offset			0.19%
Max Gain			0.15%
Max FS Error			0.34%

Table 3. Errors Due to Active Components (B-Grade)

Error Component	Error	Error Value	Error %FSR
AD8226-B	Offset	58 μ V	0.06%
ADR02-B	Offset	0.06%	0.01%
ADA4091-4 (U2B)	Offset	250 μ V	0.02%
ADA4091-4 (U2C)	Offset	250 μ V	0.02%
ADA4091-4 (U2D)	Offset	250 μ V	0.02%
AD8226-B	Gain	0.10%	0.10%
RSS Offset			0.07%
RSS Gain			0.10%
RSS FS Error			0.17%
Max Offset			0.13%
Max Gain			0.10%
Max FS Error			0.23%

Total Circuit Accuracy

A good approximation to the total error contributed by the resistor tolerances is to assume that each of the critical resistors contribute equally to the total error. The six critical resistors are R3, R7, R8, R12, R13, and R15. Worst-case tolerance build up of 0.1% resistors yields a total resistor error of 0.6% maximum. If rss errors are assumed, then the total rss error is $0.1\sqrt{6} = 0.245\%$.

Adding the worst-case resistor tolerance error of 0.6% to the previous worst-case errors due to the active components (A-grade) yields:

- Offset Error = 0.19% + 0.6% = 0.79%
- Gain Error = 0.15% + 0.6% = 0.75%
- Full Scale Error = 0.34% + 0.6% = 0.94%

These errors assume calculated resistor values are selected and that the only errors are due to their tolerances.

Although the circuit is capable of 1% or less total error, if better accuracy is required, add offset and gain adjustment capability to the circuit. Offset can be calibrated by adjusting R7 or R8 for 4 mA output with zero input, and full-scale can then be adjusted by varying R3 for a full-scale 100 mV input. The two adjustments are independent, provided the offset is calibrated first.

Actual error data from the circuit is shown in Figure 4 with $V_{CC} = 25$ V. The total error in the output current (%FSR) is calculated by taking the difference between the ideal output current and the measured output current, dividing by the FSR (16 mA), and multiplying the result by 100.

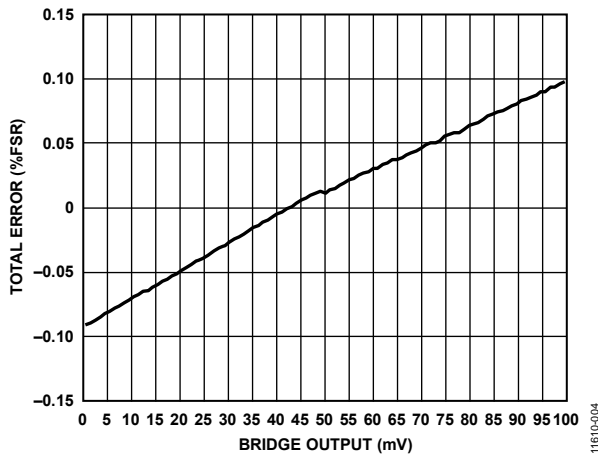

Figure 4. Total Error in Output Current (%FSR) vs. Bridge Voltage for $V_{CC} = 25$ V

COMMON VARIATIONS

The circuit is proven to work with good stability and accuracy with component values shown. Other Analog Devices, Inc. voltage references, precision op-amps, and in-amps can be used in this configuration to develop 4 mA to 20 mA analog current output and for other various applications for this circuit.

The AD8426, a dual-channel, low cost and a wide supply range instrumentation amplifier can also be used for multiple input channel application.

The ADR4550, high precision, low power, low noise voltage references can be used to replace ADR02 for a low voltage supply applications.

CIRCUIT EVALUATION AND TEST

Equipment Required

- EVAL-CN0295-EB1Z Evaluation Board
- Agilent 36311A Precision DC Power Supply
- Yokogawa 2000 Precision DC Power Supply
- Agilent 3458A Precision Multimeter

The linearity error at the current output of the evaluation board was measured with a setup seen in Figure 5.

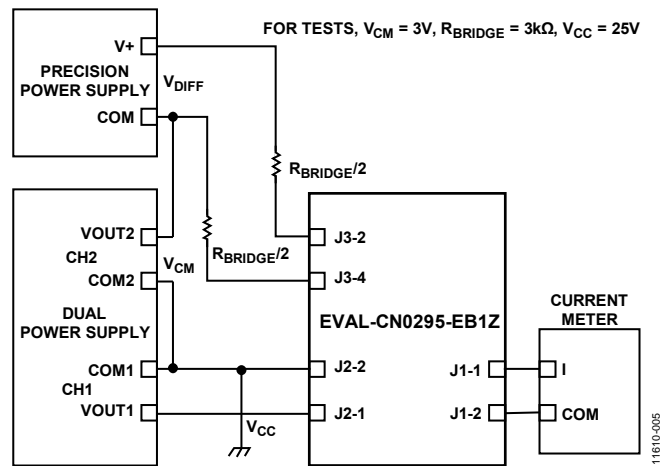

Figure 5. Block Diagram for the Test Setup

Test

Agilent E3631A and Yokogawa precision voltage supply were used to power up the board and simulate the sensor output. CH2 of Agilent E3631A was set at 25 V to serve as the power supply for the board and the other channel, CH1, was set at 2.5 V to generate common mode voltage. This channel was connected in series with the Yokogawa 2000 as shown in Figure 5. The Yokogawa generates the 0 to 100 mV differential input voltage at the in-amp input, which then simulates the sensor output.

The Agilent 3458A was used to measure the actual current output of the evaluation board, which is connected in series with J1.

LEARN MORE

CN-0295 Design Support Package:

<http://www.analog.com/CN0295-DesignSupport>

MT-035 Tutorial, *Op Amp Inputs, Outputs, Single-Supply, and Rail-to-Rail Issues*. Analog Devices.

MT-051 Tutorial, *Current Feedback Op Amp Noise Considerations*

MT-065 Tutorial, *In-Amp Noise*

MT-066 Tutorial, *In-Amp Bridge Circuit Error Budget Analysis*

MT-087 Tutorial, *Voltage References*

MT-031 Tutorial, *Grounding Data Converters and Solving the Mystery of AGND and DGND*. Analog Devices.

MT-101 Tutorial, *Decoupling Techniques*. Analog Devices.

Voltage Reference Wizard Design Tool.

Data Sheets and Evaluation Boards

[AD8226 Data Sheet](#)

[ADA4091-4 Data Sheet](#)

[ADR02 Data Sheet](#)

REVISION HISTORY

5/13—Revision 0: Initial Version

(Continued from first page) Circuits from the Lab circuits are intended only for use with Analog Devices products and are the intellectual property of Analog Devices or its licensors. While you may use the Circuits from the Lab circuits in the design of your product, no other license is granted by implication or otherwise under any patents or other intellectual property by application or use of the Circuits from the Lab circuits. Information furnished by Analog Devices is believed to be accurate and reliable. However, Circuits from the Lab circuits are supplied "as is" and without warranties of any kind, express, implied, or statutory including, but not limited to, any implied warranty of merchantability, noninfringement or fitness for a particular purpose and no responsibility is assumed by Analog Devices for their use, nor for any infringements of patents or other rights of third parties that may result from their use. Analog Devices reserves the right to change any Circuits from the Lab circuits at any time without notice but is under no obligation to do so.

©2013 Analog Devices, Inc. All rights reserved. Trademarks and registered trademarks are the property of their respective owners.
CN11610-0-5/13(0)





Стандарт Электрон Связь

Мы молодая и активно развивающаяся компания в области поставок электронных компонентов. Мы поставляем электронные компоненты отечественного и импортного производства напрямую от производителей и с крупнейших складов мира.

Благодаря сотрудничеству с мировыми поставщиками мы осуществляем комплексные и плановые поставки широчайшего спектра электронных компонентов.

Собственная эффективная логистика и склад в обеспечивает надежную поставку продукции в точно указанные сроки по всей России.

Мы осуществляем техническую поддержку нашим клиентам и предпродажную проверку качества продукции. На все поставляемые продукты мы предоставляем гарантию .

Осуществляем поставки продукции под контролем ВП МО РФ на предприятия военно-промышленного комплекса России , а также работаем в рамках 275 ФЗ с открытием отдельных счетов в уполномоченном банке. Система менеджмента качества компании соответствует требованиям ГОСТ ISO 9001.

Минимальные сроки поставки, гибкие цены, неограниченный ассортимент и индивидуальный подход к клиентам являются основой для выстраивания долгосрочного и эффективного сотрудничества с предприятиями радиоэлектронной промышленности, предприятиями ВПК и научно-исследовательскими институтами России.

С нами вы становитесь еще успешнее!

Наши контакты:

Телефон: +7 812 627 14 35

Электронная почта: sales@st-electron.ru

Адрес: 198099, Санкт-Петербург,
Промышленная ул, дом № 19, литера Н,
помещение 100-Н Офис 331