

6 PIN DIP ZERO CROSS TRIAC DRIVER PHOTOCOUPLER

EL303X Series
EL304X Series
EL306X Series
EL308X Series

Features:

- Peak breakdown voltage
 - 250V: EL303X
 - 400V: EL304X
 - 600V: EL306X
 - 800V: EL308X
- High isolation voltage between input and output (Viso=5000 V rms)
- Zero voltage crossing
- Pb free and RoHS compliant.
- UL approved (No.E214129)
- VDE approved (No.132249)
- SEMKO approval (pending)
- NEMKO approval (pending)
- DEMKO approval (pending)
- FIMKO approval (pending)
- CSA approved (No. 2007798)

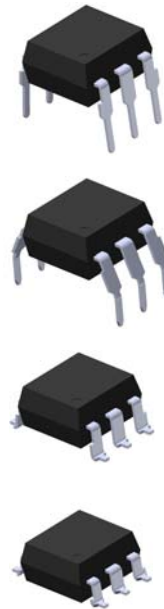

Description

The EL303X, EL304X, EL306X and EL308X series of devices each consist of a GaAs infrared emitting diode optically coupled to a monolithic silicon zero voltage crossing photo triac.

They are designed for use with a discrete power triac in the interface of logic systems to equipment powered from 110 to 380 VAC lines, such as solid-state relays, industrial controls, motors, solenoids and consumer appliances.

Applications

- Solenoid/valve controls
- Light controls
- Static power switch
- AC motor drivers
- E.M. contactors
- Temperature controls
- AC Motor starters

Schematic

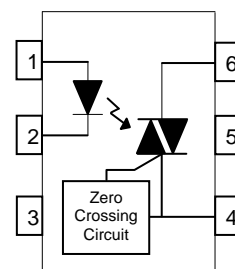

Pin Configuration

1. Anode
2. Cathode
3. No Connection
4. Terminal
5. Substrate
(do not connect)
6. Terminal



LIGHTING FOREVER

6 PIN DIP ZERO CROSS TRIAC DRIVER PHOTOCOUPLER

EL303X Series
EL304X Series
EL306X Series
EL308X Series

Absolute Maximum Ratings (T_a=25°C)

Parameter		Symbol	Rating	Unit	
Input	Forward current	I _F	60	mA	
	Reverse voltage	V _R	6	V	
	Power dissipation	P _D	100	mW	
	Derating factor (above 85°C)		3.8	mW /°C	
Output	Off-state Output Terminal Voltage	V _{DRM}	EL303X	250	V
			EL304X	400	
			EL306X	600	
			EL308X	800	
	Peak Repetitive Surge Current	I _{TSM}	1	A	
	Power dissipation	P _D	300	mW	
Derating factor (above 85°C)	7.6		mW /°C		
Isolation voltage *1		V _{iso}	5000	V rms	
Total power dissipation		P _D	330	mW	
Operating temperature		T _{opr}	-55~+100	°C	
Storage temperature		T _{stg}	-55~+125	°C	
Soldering temperature *2		T _{sol}	260	°C	

Notes

*1 AC for 1 minute, R.H.= 40 ~ 60% R.H. In this test, pins 1, 2 & 3 are shorted together, and pins 4, 5 & 6 are shorted together.

*2 For 10 seconds.

6 PIN DIP ZERO CROSS TRIAC DRIVER PHOTOCOUPLER

**EL303X Series
EL304X Series
EL306X Series
EL308X Series**

Electrical Characteristics (T_a=25°C unless specified otherwise)

Input

Parameter	Symbol	Min.	Typ.*	Max.	Unit	Condition
Forward voltage	V _F	-	-	1.5	V	I _F = 30mA
Reverse Leakage current	I _R	-	-	10	μA	V _R = 6V

Output

Parameter	Symbol	Min.	Typ.*	Max.	Unit	Condition
Peak Blocking Current	EL303X/304X	-	-	100	nA	V _{DRM} = Rated V _{DRM} I _F = 0mA
	EL306X/308X			500		
Peak On-state Voltage	V _{TM}	-	-	3	V	I _{TM} =100mA peak, I _F =Rated I _{FT}
Critical Rate of Rise of off-state Voltage	EL303X /304X /306X	1000	-	-	V/μs	V _{PEAK} =Rated V _{DRM} , I _F =0 (Fig. 10)
	EL308X	600	-	-		
Inhibit Voltage (MT1-MT2 voltage above which device will not trigger)	V _{INH}	-	-	20	V	I _F = Rated I _{FT}
Leakage in Inhibited State	I _{DRM2}	-	-	500	μA	I _F = Rated I _{FT} , V _{DRM} =Rated V _{DRM} , off state

Transfer Characteristics

Parameter	Symbol	Min.	Typ.*	Max.	Unit	Condition
LED Trigger Current	I _{FT}	-	-	15	mA	Main terminal Voltage=3V
				10		
				5		
Holding Current	I _H	-	280	-	μA	

* Typical values at T_a = 25°C

6 PIN DIP ZERO CROSS TRIAC DRIVER PHOTOCOUPLER

**EL303X Series
EL304X Series
EL306X Series
EL308X Series**

Typical Performance Curves

Figure 1. Forward Current vs Forward Voltage

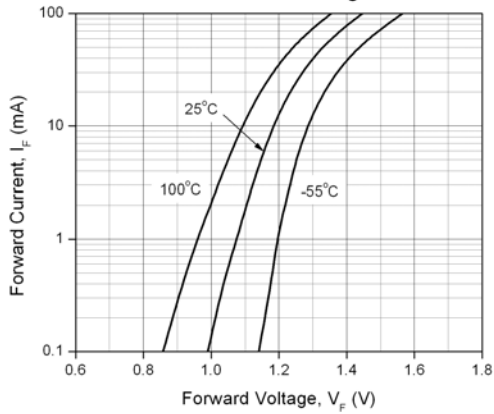

Figure 2. On-State Characteristics

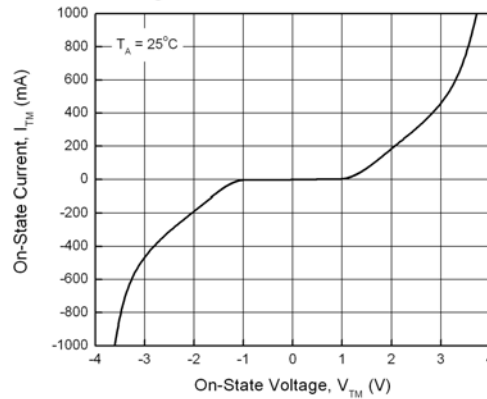

Figure 3. Holding Current vs. Ambient Temperature

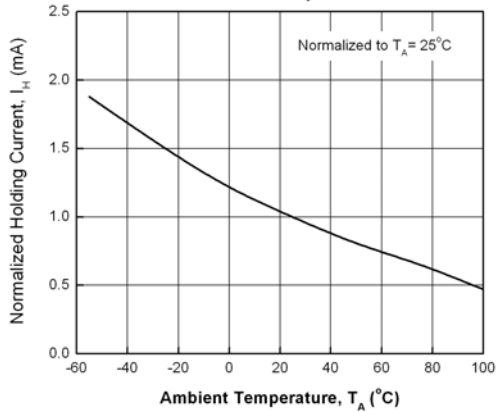

Figure 4. LED Current Required to Trigger vs. LED Pulse Width

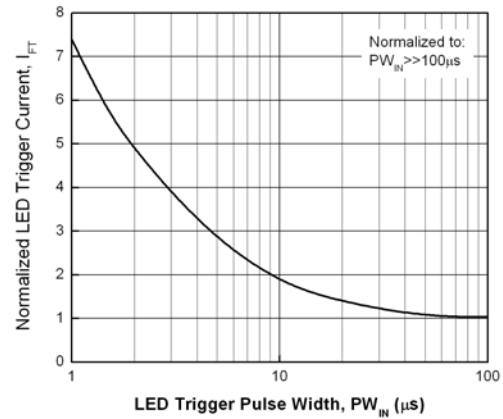

Figure 5. Leakage Current vs. Ambient Temperature

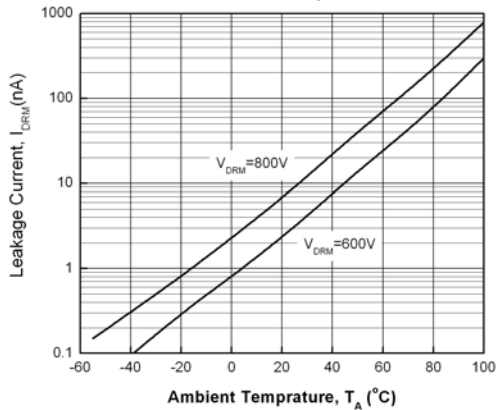
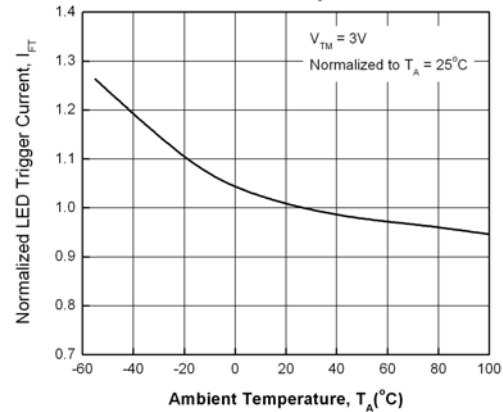

Figure 6. LED Trigger Current vs. Ambient Temperature



**6 PIN DIP ZERO CROSS TRIAC DRIVER
PHOTOCOUPLER**

**EL303X Series
EL304X Series
EL306X Series
EL308X Series**

Figure 7. Off-State Output Terminal Voltage vs. Ambient Temperature

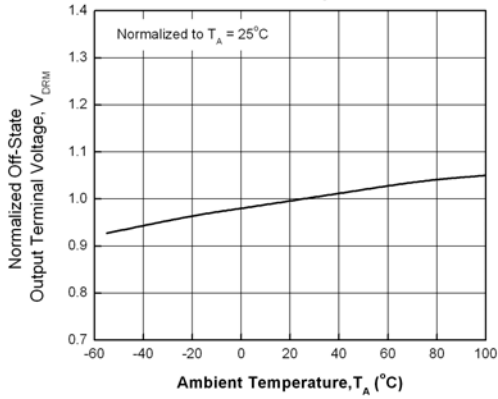

Figure 8. Leakage in Inhibit State vs. Ambient Temperature

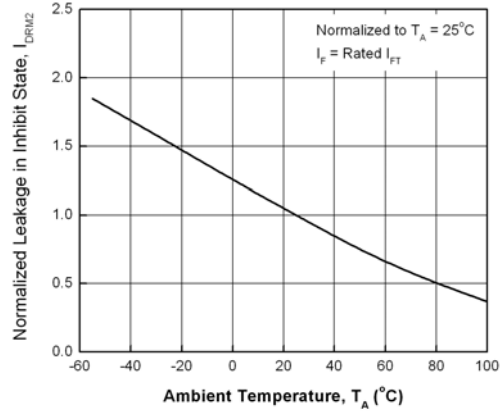

Figure 9. Inhibit Voltage vs. Ambient Temperature

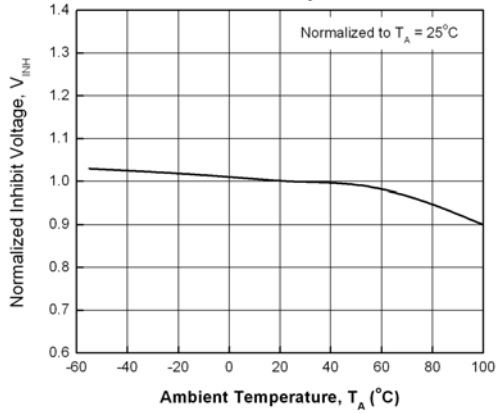
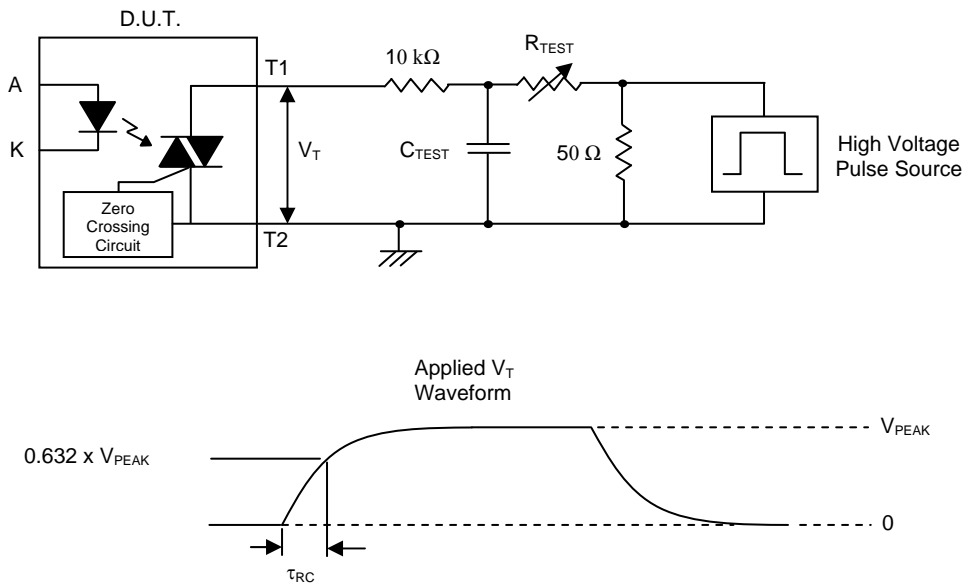

Figure 10. Static dv/dt Test Circuit & Waveform



Measurement Method

The high voltage pulse is set to the required V_{PEAK} value and applied to the D.U.T. output side through the RC circuit above. LED current is not applied. The waveform V_T is monitored using a x100 scope probe. By varying R_{TEST} , the dv/dt (slope) is increased, until the D.U.T. is observed to trigger (waveform collapses). The dv/dt is then decreased until the D.U.T. stops triggering. At this point, τ_{RC} is recorded and the dv/dt calculated.

$$dv/dt = \frac{0.632 \times V_{PEAK}}{\tau_{RC}}$$

For example, $V_{PEAK} = 600V$ for EL306X series. The dv/dt value is calculated as follows:

$$dv/dt = \frac{0.63 \times 600}{\tau_{RC}} = \frac{378}{\tau_{RC}}$$



LIGHTING FOREVER

6 PIN DIP ZERO CROSS TRIAC DRIVER PHOTOCOUPLER

EL303X Series
EL304X Series
EL306X Series
EL308X Series

Order Information

Part Number

EL303XY(Z)-V
or **EL304XY(Z)-V**
or **EL306XY(Z)-V**
or **EL308XY(Z)-V**

Note

X = Part No. (1, 2 or 3)

Y = Lead form option (S, S1, M or none)

Z = Tape and reel option (TA, TB or none).

V = VDE safety approved option

Option	Description	Packing quantity
None	Standard DIP-6	65 units per tube
M	Wide lead bend (0.4 inch spacing)	65 units per tube
S (TA)	Surface mount lead form + TA tape & reel option	1000 units per reel
S (TB)	Surface mount lead form + TB tape & reel option	1000 units per reel
S1 (TA)	Surface mount lead form (low profile) + TA tape & reel option	1000 units per reel
S1 (TB)	Surface mount lead form (low profile) + TB tape & reel option	1000 units per reel

**6 PIN DIP ZERO CROSS TRIAC DRIVER
PHOTOCOUPLER**

**EL303X Series
EL304X Series
EL306X Series
EL308X Series**

**Package Drawings
(Dimensions in mm)**

Standard DIP Type

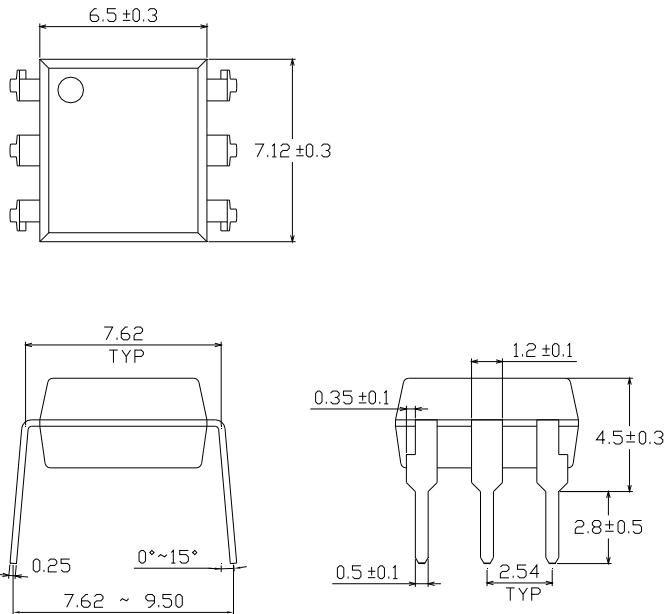

Option M Type

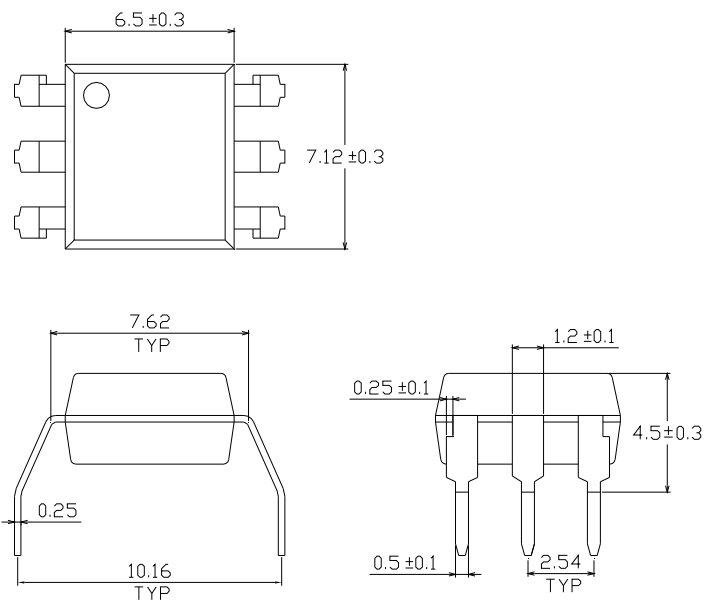

**6 PIN DIP ZERO CROSS TRIAC DRIVER
PHOTOCOUPLER**

**EL303X Series
EL304X Series
EL306X Series
EL308X Series**

Option S Type

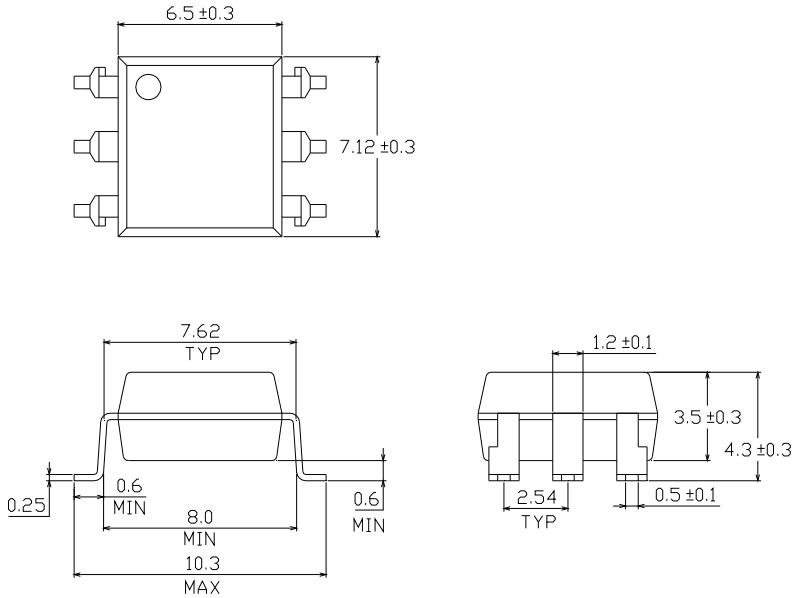

Option S1 Type

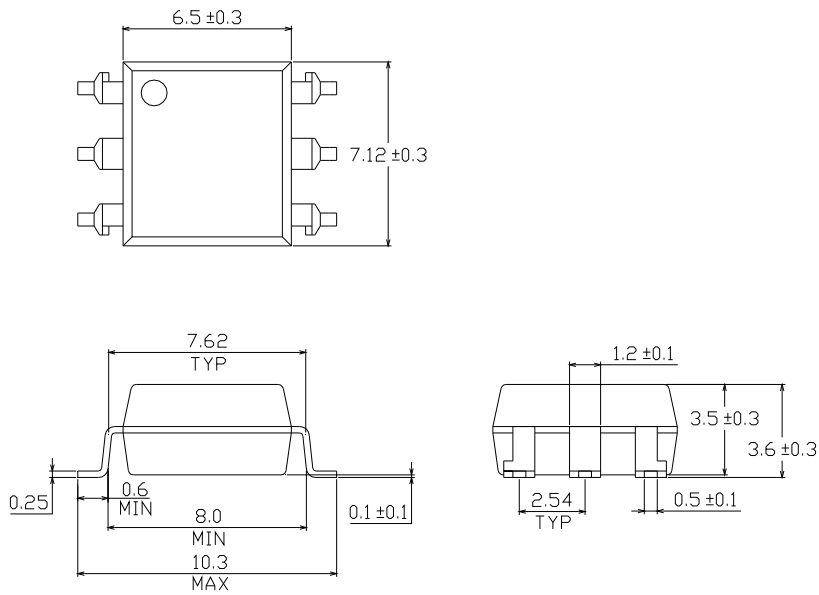

**6 PIN DIP ZERO CROSS TRIAC DRIVER
PHOTOCOUPLER**

**EL303X Series
EL304X Series
EL306X Series
EL308X Series**

Recommended pad layout for surface mount leadform

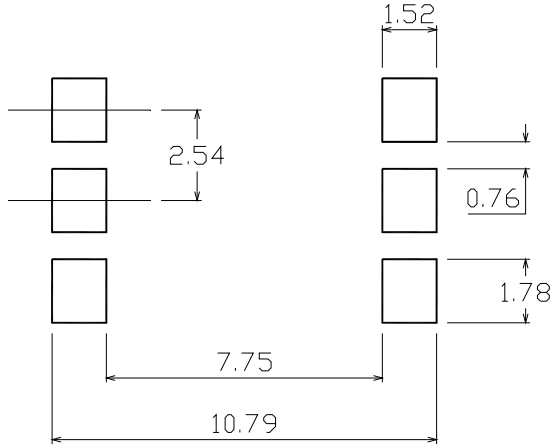

Device Marking

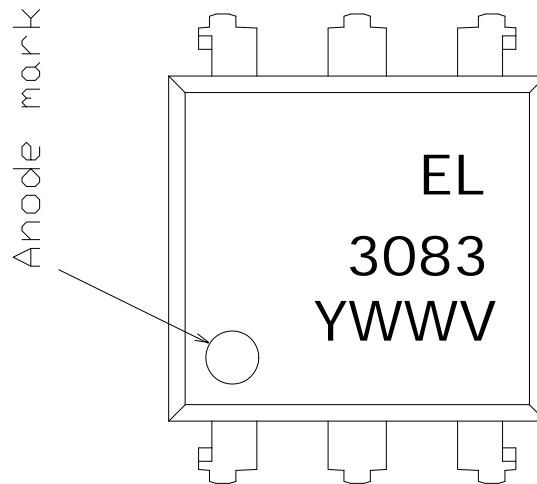

Notes

- EL denotes Everlight
- 3083 denotes Device Number
- Y denotes 1 digit Year code
- WW denotes 2 digit Week code
- V denotes VDE option

6 PIN DIP ZERO CROSS TRIAC DRIVER PHOTOCOUPLER

EL303X Series
EL304X Series
EL306X Series
EL308X Series

Tape & Reel Packing Specifications

Option TA

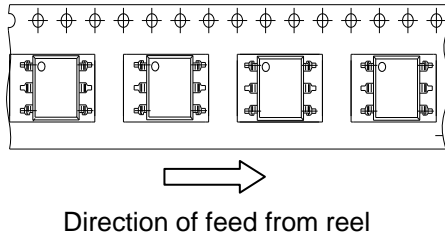

Option TB

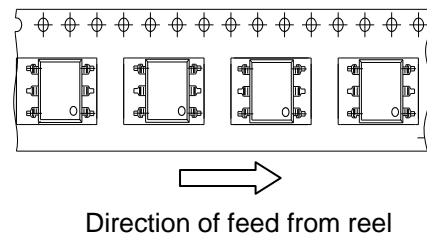

Tape dimensions

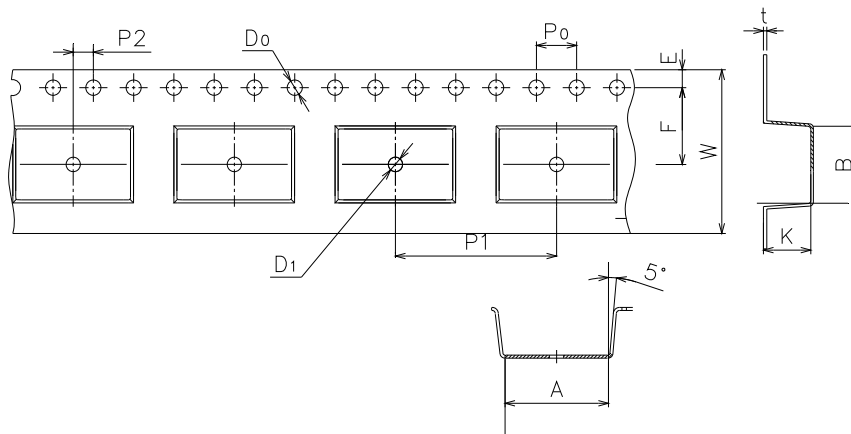

Dimension No.	A	B	Do	D1	E	F
Dimension (mm)	10.4±0.1	7.52±0.1	1.5+0.1/-0	1.5+0.1/-0	1.75±0.1	7.5±0.1

Dimension No.	Po	P1	P2	t	W	K
Dimension (mm)	4.0±0.15	1.6±0.1	2.0±0.1	0.35±0.03	16.0±0.2	4.5±0.1

6 PIN DIP ZERO CROSS TRIAC DRIVER PHOTOCOUPLER

EL303X Series
EL304X Series
EL306X Series
EL308X Series

Solder Reflow Temperature Profile

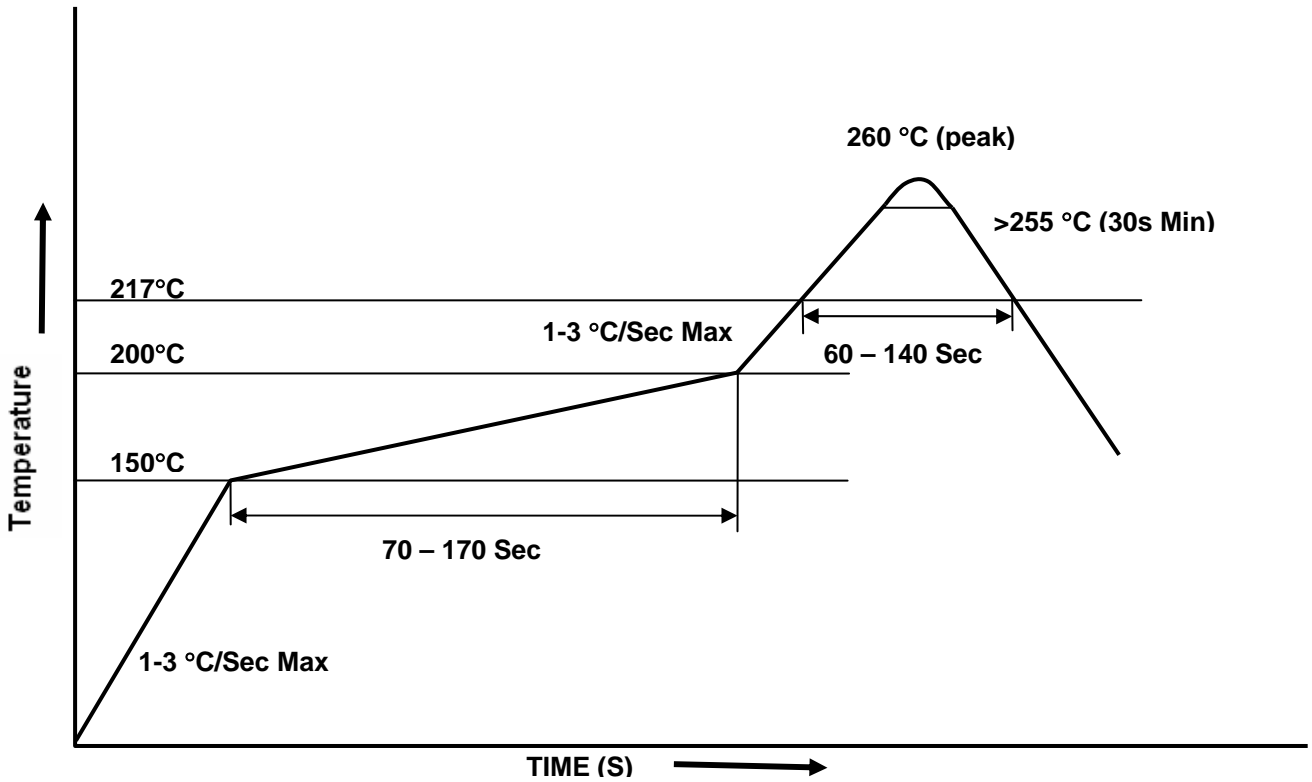



LIGHTING FOREVER

6 PIN DIP ZERO CROSS TRIAC DRIVER PHOTOCOUPLER

EL303X Series
EL304X Series
EL306X Series
EL308X Series

DISCLAIMER

1. Above specification may be changed without notice. EVERLIGHT will reserve authority on material change for above specification.
2. When using this product, please observe the absolute maximum ratings and the instructions for use outlined in these specification sheets. EVERLIGHT assumes no responsibility for any damage resulting from use of the product which does not comply with the absolute maximum ratings and the instructions included in these specification sheets.
3. These specification sheets include materials protected under copyright of EVERLIGHT. Reproduction in any form is prohibited without the specific consent of EVERLIGHT.



Стандарт Электрон Связь

Мы молодая и активно развивающаяся компания в области поставок электронных компонентов. Мы поставляем электронные компоненты отечественного и импортного производства напрямую от производителей и с крупнейших складов мира.

Благодаря сотрудничеству с мировыми поставщиками мы осуществляем комплексные и плановые поставки широчайшего спектра электронных компонентов.

Собственная эффективная логистика и склад в обеспечивает надежную поставку продукции в точно указанные сроки по всей России.

Мы осуществляем техническую поддержку нашим клиентам и предпродажную проверку качества продукции. На все поставляемые продукты мы предоставляем гарантию .

Осуществляем поставки продукции под контролем ВП МО РФ на предприятия военно-промышленного комплекса России , а также работаем в рамках 275 ФЗ с открытием отдельных счетов в уполномоченном банке. Система менеджмента качества компании соответствует требованиям ГОСТ ISO 9001.

Минимальные сроки поставки, гибкие цены, неограниченный ассортимент и индивидуальный подход к клиентам являются основой для выстраивания долгосрочного и эффективного сотрудничества с предприятиями радиоэлектронной промышленности, предприятиями ВПК и научно-исследовательскими институтами России.

С нами вы становитесь еще успешнее!

Наши контакты:

Телефон: +7 812 627 14 35

Электронная почта: sales@st-electron.ru

Адрес: 198099, Санкт-Петербург,
Промышленная ул, дом № 19, литера Н,
помещение 100-Н Офис 331