

### FEATURES

- 8.0 GHz bandwidth
- 3.2 V to 3.6 V power supply
- Separate charge pump supply ( $V_P$ ) allows extended tuning voltage in 3.3 V systems
- Programmable, dual modulus prescaler 8/9, 16/17, 32/33, or 64/65
- Programmable charge pump currents
- Programmable antibacklash pulse width
- 3-wire serial interface
- Analog and digital lock detect
- Hardware and software power-down mode
- Loop filter design possible with ADIsimPLL

### APPLICATIONS

- Broadband wireless access
- Satellite systems
- Instrumentation
- Wireless LANs
- Base stations for wireless radio

### GENERAL DESCRIPTION

The ADF4108 frequency synthesizer can be used to implement local oscillators in the up-conversion and down-conversion sections of wireless receivers and transmitters. It consists of a low noise digital PFD (phase frequency detector), a precision charge pump, a programmable reference divider, programmable A and B counters, and a dual-modulus prescaler ( $P/P + 1$ ). The A (6-bit) and B (13-bit) counters, in conjunction with the dual-modulus prescaler ( $P/P + 1$ ), implement an N divider ( $N = BP + A$ ). In addition, the 14-bit reference counter (R counter), allows selectable REF<sub>IN</sub> frequencies at the PFD input. A complete phase-locked loop (PLL) can be implemented if the synthesizer is used with an external loop filter and voltage controlled oscillator (VCO). Its very high bandwidth means that frequency doublers can be eliminated in many high frequency systems, simplifying system architecture and reducing cost.

### FUNCTIONAL BLOCK DIAGRAM

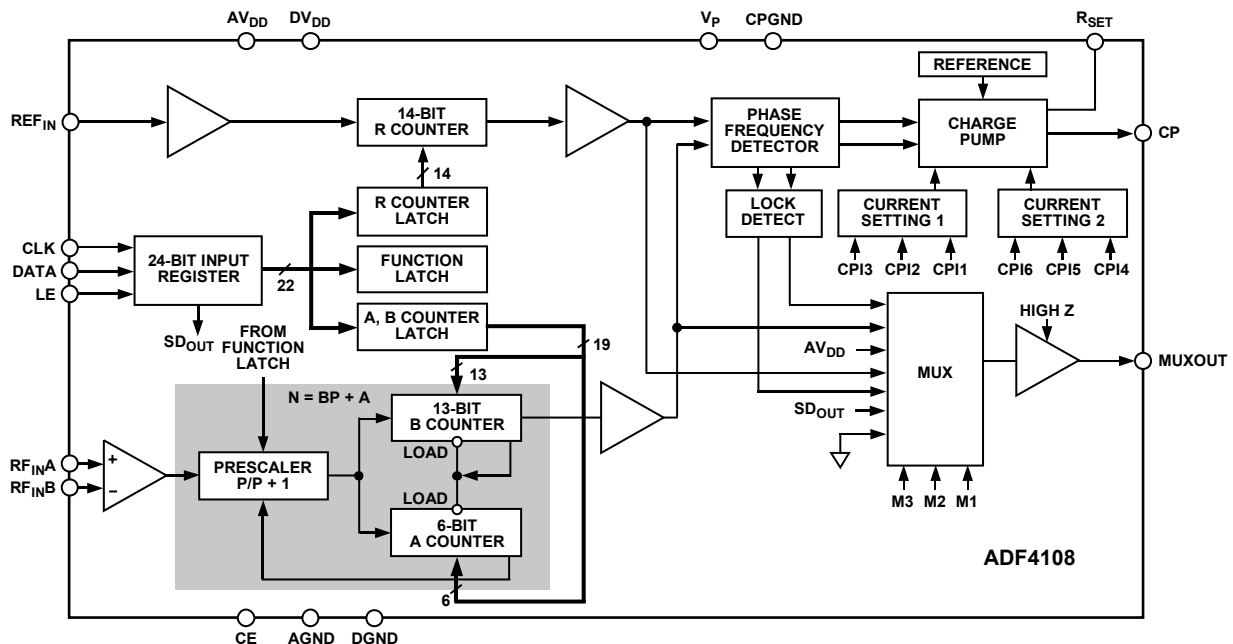

Figure 1.

0815-001

### Rev. 0

Information furnished by Analog Devices is believed to be accurate and reliable. However, no responsibility is assumed by Analog Devices for its use, nor for any infringements of patents or other rights of third parties that may result from its use. Specifications subject to change without notice. No license is granted by implication or otherwise under any patent or patent rights of Analog Devices. Trademarks and registered trademarks are the property of their respective owners.

**TABLE OF CONTENTS**

Features .....	1	Phase Frequency Detector and Charge Pump.....	9
Applications.....	1	MUXOUT and Lock Detect.....	10
General Description .....	1	Input Shift Register .....	10
Functional Block Diagram .....	1	Latch Summary.....	11
Revision History .....	2	Reference Counter Latch Map.....	12
Specifications.....	3	AB Counter Latch Map .....	13
Timing Characteristics.....	5	Function Latch Map.....	14
Absolute Maximum Rating .....	6	Initialization Latch Map .....	15
ESD Caution.....	6	Function Latch.....	16
Pin Configuration and Function Descriptions.....	7	Initialization Latch .....	17
Typical Performance Characteristics .....	8	Power Supply Considerations.....	17
Theory of Operation .....	9	Interfacing .....	18
Reference Input Stage.....	9	ADuC812 Interface .....	18
RF Input Stage.....	9	ADSP-2181 Interface .....	18
Prescaler (P/P + 1).....	9	PCB Design Guidelines for Chip Scale Package.....	19
A and B Counters .....	9	Outline Dimensions .....	20
R Counter .....	9	Ordering Guide .....	20

**REVISION HISTORY****4/06—Revision 0: Initial Version**

## SPECIFICATIONS

$AV_{DD} = DV_{DD} = 3.3 V \pm 2\%$ ,  $AV_{DD} \leq V_P \leq 5.5 V$ ,  $AGND = DGND = CPGND = 0 V$ ,  $R_{SET} = 5.1 k\Omega$ , dBm referred to  $50 \Omega$ ,  $T_A = T_{MIN}$  to  $T_{MAX}$ , unless otherwise noted.

**Table 1.**

Parameter	B Version <sup>1</sup>	B Chips <sup>2</sup> (Typ)	Unit	Test Conditions/Comments
<b>RF CHARACTERISTICS</b>				
RF Input Frequency ( $RF_{IN}$ )	1.0/8.0	1.0/8.0	GHz min/max	See Figure 12 for input circuit
RF Input Sensitivity	-5/+5	-5/+5	dBm min/max	For lower frequencies ensure slew rate (SR) > 320 V/ $\mu$ s
Maximum Allowable Prescaler Output Frequency <sup>3</sup>	300	300	MHz max	P = 8
	325	325	MHz max	P = 16
<b>REF<sub>IN</sub> CHARACTERISTICS</b>				
REF <sub>IN</sub> Input Frequency	20/250	20/250	MHz min/max	For f < 20 MHz, ensure SR > 50 V/ $\mu$ s
REF <sub>IN</sub> Input Sensitivity <sup>4</sup>	0.8/ $V_{DD}$	0.8/ $V_{DD}$	V p-p min/max	Biased at $AV_{DD}/2$ <sup>5</sup>
REF <sub>IN</sub> Input Capacitance	10	10	pF max	
REF <sub>IN</sub> Input Current	$\pm 100$	$\pm 100$	$\mu$ A max	
<b>PHASE DETECTOR</b>				
Phase Detector Frequency <sup>6</sup>	104	104	MHz max	
<b>CHARGE PUMP</b>				
$I_{CP}$ Sink/Source				Programmable; see Figure 19
High Value	5	5	mA typ	With $R_{SET} = 5.1 k\Omega$
Low Value	625	625	$\mu$ A typ	
Absolute Accuracy	2.5	2.5	% typ	With $R_{SET} = 5.1 k\Omega$
$R_{SET}$ Range	3.0/11	3.0/11	k $\Omega$ typ	See Figure 19
$I_{CP}$ Three-State Leakage	1	1	nA typ	1 nA typical; $T_A = 25^\circ C$
Sink and Source Current Matching	2	2	% typ	$0.5 V \leq V_{CP} \leq V_P - 0.5 V$
$I_{CP}$ vs. $V_{CP}$	1.5	1.5	% typ	$0.5 V \leq V_{CP} \leq V_P - 0.5 V$
$I_{CP}$ vs. Temperature	2	2	% typ	$V_{CP} = V_P/2$
<b>LOGIC INPUTS</b>				
$V_{IH}$ , Input High Voltage	1.4	1.4	V min	
$V_{IL}$ , Input Low Voltage	0.6	0.6	V max	
$I_{INH}$ , $I_{INL}$ , Input Current	$\pm 1$	$\pm 1$	$\mu$ A max	
$C_{IN}$ , Input Capacitance	10	10	pF max	
<b>LOGIC OUTPUTS</b>				
$V_{OH}$ , Output High Voltage	1.4	1.4	V min	Open-drain output chosen; 1 k $\Omega$ pull-up resistor to 1.8 V
$V_{OH}$ , Output High Voltage	$V_{DD} - 0.4$	$V_{DD} - 0.4$	V min	CMOS output chosen
$I_{OH}$	100	100	$\mu$ A max	
$V_{OL}$ , Output Low Voltage	0.4	0.4	V max	$I_{OL} = 500 \mu A$
<b>POWER SUPPLIES</b>				
$AV_{DD}$	3.2/3.6	3.2/3.6	V min/V max	
$DV_{DD}$	$AV_{DD}$	$AV_{DD}$		
$V_P$	$AV_{DD}/5.5$	$AV_{DD}/5.5$	V min/V max	$AV_{DD} \leq V_P \leq 5.5 V$
$I_{DD}$ ( $AI_{DD} + DI_{DD}$ ) <sup>7</sup>	17	17	mA max	15 mA typ
$I_P$	0.4	0.4	mA max	$T_A = 25^\circ C$
Power-Down Mode ( $AI_{DD} + DI_{DD}$ ) <sup>8</sup>	10	10	$\mu$ A typ	

# ADF4108

Parameter	B Version <sup>1</sup>	B Chips <sup>2</sup> (Typ)	Unit	Test Conditions/Comments
<b>NOISE CHARACTERISTICS</b>				
Normalized Phase Noise Floor <sup>9</sup>	-219	-219	dBc/Hz typ	@ VCO output
Phase Noise Performance <sup>10</sup> 7900 MHz Output <sup>11</sup>	-81	-81	dBc/Hz typ	@ 1 kHz offset and 1 MHz PFD frequency
Spurious Signals 7900 MHz Output <sup>11</sup>	-61	-61	dBc typ	@ 1 MHz offset and 1 MHz PFD frequency

<sup>1</sup> Operating temperature range (B version) is -40°C to +85°C.

<sup>2</sup> The B chip specifications are given as typical values.

<sup>3</sup> This is the maximum operating frequency of the CMOS counters. The prescaler value should be chosen to ensure that the RF input is divided down to a frequency that is less than this value.

<sup>4</sup>  $AV_{DD} = DV_{DD} = 3.3\text{ V}$ .

<sup>5</sup> AC coupling ensures  $AV_{DD}/2$  bias.

<sup>6</sup> Guaranteed by design. Sample tested to ensure compliance.

<sup>7</sup>  $T_A = 25^\circ\text{C}$ ;  $AV_{DD} = DV_{DD} = 3.3\text{ V}$ ;  $P = 32$ ;  $RF_{IN} = 8\text{ GHz}$ ;  $f_{PFD} = 200\text{ kHz}$ ;  $REF_{IN} = 10\text{ MHz}$ .

<sup>8</sup>  $T_A = 25^\circ\text{C}$ ;  $AV_{DD} = DV_{DD} = 3.3\text{ V}$ ;  $R = 16,383$ ;  $A = 63$ ;  $B = 891$ ;  $P = 32$ ;  $RF_{IN} = 7.0\text{ GHz}$ .

<sup>9</sup> This value can be used to calculate phase noise for any application. Use the formula  $-219 + 10 \log(f_{PFD}) + 20 \log N$  to calculate in-band phase noise performance as seen at the VCO output. The value given is the lowest noise mode.

<sup>10</sup> The phase noise is measured with the EVAL-ADF4108EB1 evaluation board, with the Hittite HMC506LP4 VCO. The spectrum analyzer provides the  $REF_{IN}$  for the synthesizer ( $f_{REFOUT} = 10\text{ MHz}$  @ 0 dBm).

<sup>11</sup>  $f_{REFIN} = 10\text{ MHz}$ ;  $f_{PFD} = 1\text{ MHz}$ ;  $f_{RF} = 7900\text{ MHz}$ ;  $N = 7900$ ; loop B/W = 50 kHz, VCO = HMC506LP4, spurs are dominated by the leakage current on the tuning port of the HMC506LP4 VCO.

## TIMING CHARACTERISTICS

$AV_{DD} = DV_{DD} = 3.3\text{ V} \pm 2\%$ ,  $AV_{DD} \leq V_P \leq 5.5\text{ V}$ ,  $AGND = DGND = CPGND = 0\text{ V}$ ,  $R_{SET} = 5.1\text{ k}\Omega$ , dBm referred to  $50\ \Omega$ ,  $T_A = T_{MIN}$  to  $T_{MAX}$ , unless otherwise noted.

Table 2.

Parameter <sup>1</sup>	Limit <sup>2</sup> (B Version)	Unit	Test Conditions/Comments
t <sub>1</sub>	10	ns min	DATA to CLOCK setup time
t <sub>2</sub>	10	ns min	DATA to CLOCK hold time
t <sub>3</sub>	25	ns min	CLOCK high duration
t <sub>4</sub>	25	ns min	CLOCK low duration
t <sub>5</sub>	10	ns min	CLOCK to LE setup time
t <sub>6</sub>	20	ns min	LE pulse width

<sup>1</sup> Guaranteed by design but not production tested.

<sup>2</sup> Operating temperature range (B Version) is  $-40^\circ\text{C}$  to  $+85^\circ\text{C}$ .

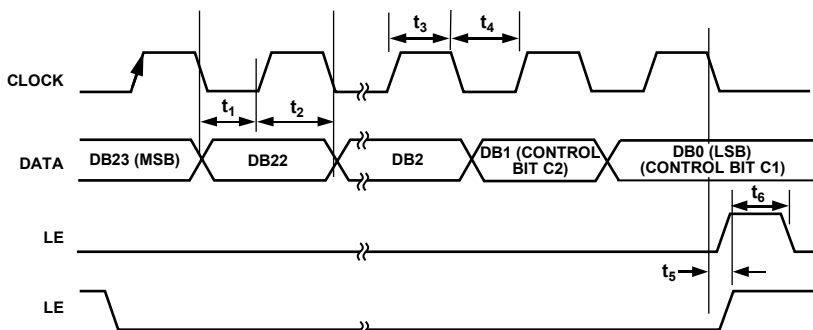

Figure 2. Timing Diagram

06015-002

## ABSOLUTE MAXIMUM RATING

T<sub>A</sub> = 25°C, unless otherwise noted.

**Table 3.**

Parameter	Rating
AV <sub>DD</sub> to GND <sup>1</sup>	–0.3 V to +3.9 V
AV <sub>DD</sub> to DV <sub>DD</sub>	–0.3 V to +0.3 V
V <sub>P</sub> to GND	–0.3 V to +5.8 V
V <sub>P</sub> to AV <sub>DD</sub>	–0.3 V to +5.8 V
Digital I/O Voltage to GND	–0.3 V to V <sub>DD</sub> + 0.3 V
Analog I/O Voltage to GND	–0.3 V to V <sub>P</sub> + 0.3 V
REFIN, RF <sub>IN</sub> A, RF <sub>IN</sub> B to GND	–0.3 V to V <sub>DD</sub> + 0.3 V
Operating Temperature Range	
Industrial (B Version)	–40°C to +85°C
Storage Temperature Range	–65°C to +125°C
Maximum Junction Temperature	150°C
TSSOP θ <sub>JA</sub> Thermal Impedance	112°C/W
CSP θ <sub>JA</sub> Thermal Impedance (Paddle Soldered)	30.4°C/W
Reflow Soldering	
Peak Temperature (60 sec)	260
Time at Peak Temperature	40 sec
Transistor Count	
CMOS	6425
Bipolar	303

<sup>1</sup> GND = AGND = DGND = 0 V.

### ESD CAUTION

ESD (electrostatic discharge) sensitive device. Electrostatic charges as high as 4000 V readily accumulate on the human body and test equipment and can discharge without detection. Although this product features proprietary ESD protection circuitry, permanent damage may occur on devices subjected to high energy electrostatic discharges. Therefore, proper ESD precautions are recommended to avoid performance degradation or loss of functionality.

Stresses above those listed under Absolute Maximum Ratings may cause permanent damage to the device. This is a stress rating only; functional operation of the device at these or any other conditions above those indicated in the operational section of this specification is not implied. Exposure to absolute maximum rating conditions for extended periods may affect device reliability.

This device is a high performance RF integrated circuit with an ESD rating of <2 kV, and it is ESD sensitive. Proper precautions should be taken for handling and assembly.



## PIN CONFIGURATION AND FUNCTION DESCRIPTIONS

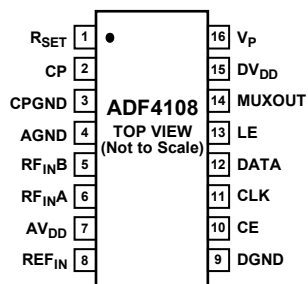

NOTE: TRANSISTOR COUNT 6425 (CMOS), 303 (BIPOlar).  
06015-030

Figure 3. TSSOP Pin Configuration for TSSOP

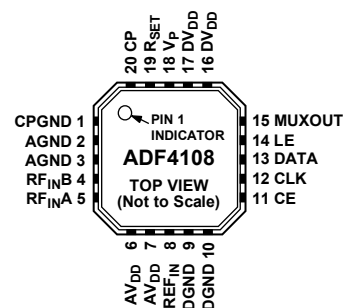

Figure 4. LFCSP\_VQ Pin Configuration

Table 4. Pin Function Descriptions

Pin No.		Mnemonic	Description
TSSOP	LFCSP_VQ		
1	19	R <sub>SET</sub>	Connecting a resistor between this pin and CPGND sets the maximum charge pump output current. The nominal voltage potential at the R <sub>SET</sub> pin is 0.66 V. The relationship between I <sub>CP</sub> and R <sub>SET</sub> is $I_{CP\ MAX} = \frac{25.5}{R_{SET}}$ with R <sub>SET</sub> = 5.1 kΩ, I <sub>CP MAX</sub> = 5 mA.
2	20	CP	Charge Pump Output. When enabled, this pin provides ±I <sub>CP</sub> to the external loop filter, which in turn drives the external VCO.
3	1	CPGND	Charge Pump Ground. This is the ground return path for the charge pump.
4	2, 3	AGND	Analog Ground. This is the ground return path of the prescaler.
5	4	RF <sub>INB</sub>	Complementary Input to the RF Prescaler. This point must be decoupled to the ground plane with a small bypass capacitor, typically 100 pF. See Figure 12.
6	5	RF <sub>INA</sub>	Input to the RF Prescaler. This small signal input is ac-coupled to the external VCO.
7	6, 7	AV <sub>DD</sub>	Analog Power Supply. This voltage may range from 3.2 V to 3.6 V. Decoupling capacitors to the analog ground plane should be placed as close as possible to this pin. AV <sub>DD</sub> must be the same value as DV <sub>DD</sub> .
8	8	REF <sub>IN</sub>	Reference Input. This is a CMOS input with a nominal threshold of V <sub>DD</sub> /2 and a dc equivalent input resistance of 100 kΩ. See Figure 11. This input can be driven from a TTL or CMOS crystal oscillator or it can be ac-coupled.
9	9, 10	DGND	Digital Ground.
10	11	CE	Chip Enable. A logic low on this pin powers down the device and puts the charge pump output into three-state mode. Taking the pin high will power up the device, depending on the status of the power-down bit, F2.
11	12	CLK	Serial Clock Input. This serial clock is used to clock in the serial data to the registers. The data is latched into the 24-bit shift register on the CLK rising edge. This input is a high impedance CMOS input.
12	13	DATA	Serial Data Input. The serial data is loaded MSB first with the 2 LSBs being the control bits. This input is a high impedance CMOS input.
13	14	LE	Load Enable, CMOS Input. When LE goes high, the data stored in the shift registers is loaded into one of the four latches, the latch being selected using the control bits.
14	15	MUXOUT	This multiplexer output allows either the lock detect, the scaled RF, or the scaled reference frequency to be accessed externally.
15	16, 17	DV <sub>DD</sub>	Digital Power Supply. This may range from 3.2 V to 3.6 V. Decoupling capacitors to the digital ground plane should be placed as close as possible to this pin. DV <sub>DD</sub> must be the same value as AV <sub>DD</sub> .
16	18	V <sub>P</sub>	Charge Pump Power Supply. This voltage should be greater than or equal to V <sub>DD</sub> . In systems where V <sub>DD</sub> is 3.3 V, it can be set to 5 V and used to drive a VCO with a tuning range of up to 5 V.

## TYPICAL PERFORMANCE CHARACTERISTICS

FREQ UNIT: GHz		KEYWORD: R			
PARAM TYPE: s					
DATA FORMAT: MA					
Freq	MAGS11	ANGS11	Freq	MAGS11	ANGS11
0.50000	0.89148	-17.2620	4.30000	0.45555	-159.800
0.60000	0.88133	-20.6919	4.40000	0.46108	-164.916
0.70000	0.87152	-24.5386	4.50000	0.45325	-168.482
0.80000	0.85855	-27.3228	4.60000	0.43054	-173.462
0.90000	0.84911	-31.0698	4.70000	0.45200	-176.697
1.00000	0.83512	-34.8623	4.80000	0.45043	-178.824
1.10000	0.82374	-38.5574	4.90000	0.45282	-174.947
1.20000	0.80871	-41.9093	5.00000	0.44287	-170.237
1.30000	0.79176	-45.6990	5.10000	0.44909	-166.617
1.40000	0.77205	-49.4185	5.20000	0.44294	-162.786
1.50000	0.75696	-52.9898	5.30000	0.44558	-158.756
1.60000	0.74234	-56.2923	5.40000	0.45417	-153.195
1.70000	0.72239	-60.2584	5.50000	0.46038	-147.721
1.80000	0.69919	-63.1446	5.60000	0.47128	-139.750
1.90000	0.67288	-65.6464	5.70000	0.47439	-132.657
2.00000	0.65227	-68.0742	5.80000	0.48604	-125.762
2.10000	0.64758	-71.3520	5.90000	0.50637	-121.110
2.20000	0.62454	-75.5658	6.00000	0.52172	-115.400
2.30000	0.59486	-79.6404	6.10000	0.53342	-107.705
2.40000	0.55532	-82.8246	6.20000	0.53716	-101.572
2.50000	0.52256	-85.2795	6.30000	0.55804	-97.5379
2.60000	0.48754	-85.6298	6.40000	0.56362	-93.0936
2.70000	0.45411	-86.1654	6.50000	0.58365	-89.2227
2.80000	0.45776	-86.4997	6.60000	0.59248	-86.3300
2.90000	0.44859	-88.8080	6.70000	0.61066	-83.0956
3.00000	0.44588	-91.3737	6.80000	0.61930	-80.5843
3.10000	0.43810	-95.4087	6.90000	0.61633	-78.0872
3.20000	0.43269	-99.1282	7.00000	0.61673	-75.3727
3.30000	0.42777	-102.7448	7.10000	0.60597	-73.3456
3.40000	0.42859	-107.167	7.20000	0.58376	-73.5883
3.50000	0.43365	-111.863	7.30000	0.57673	-74.1975
3.60000	0.43849	-117.648	7.40000	0.59157	-76.2136
3.70000	0.44475	-123.856	7.50000	0.60040	-77.1545
3.80000	0.44800	-130.399	7.60000	0.61332	-76.1422
3.90000	0.45223	-136.744	7.70000	0.62927	-74.3359
4.00000	0.45555	-142.766	7.80000	0.63938	-74.0546
4.10000	0.45313	-149.269	7.90000	0.65320	-72.0061
4.20000	0.45622	-154.654	8.00000	0.65804	-69.9926

Figure 5. S Parameter Data for the RF Input

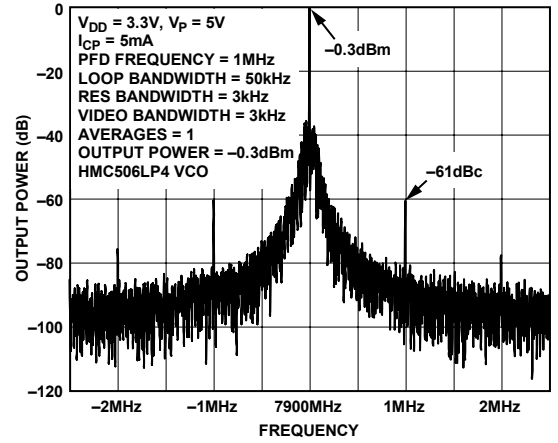

Figure 8. Reference Spurs at 7.9 GHz  
Note: The spurs are dominated by the leakage current of the tuning port on the HMC506LP4 VCO. The leakage current was measured to be 27 nA.

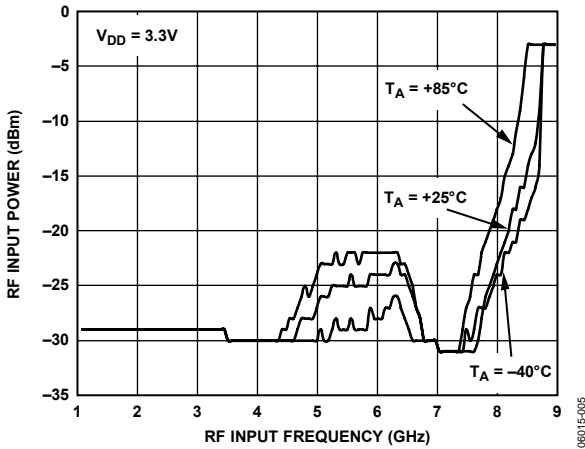

Figure 6. RF Input Sensitivity

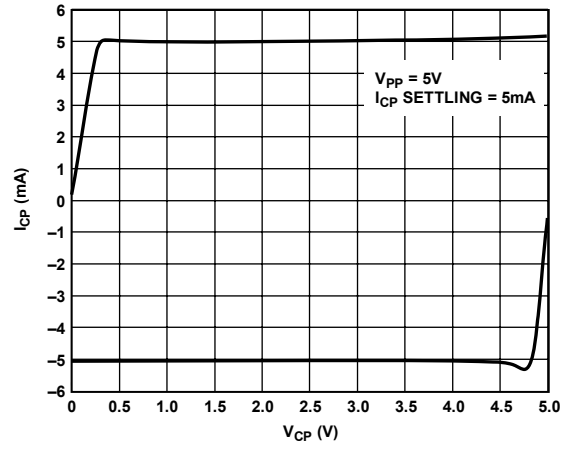

Figure 9. Charge Pump Output Characteristics

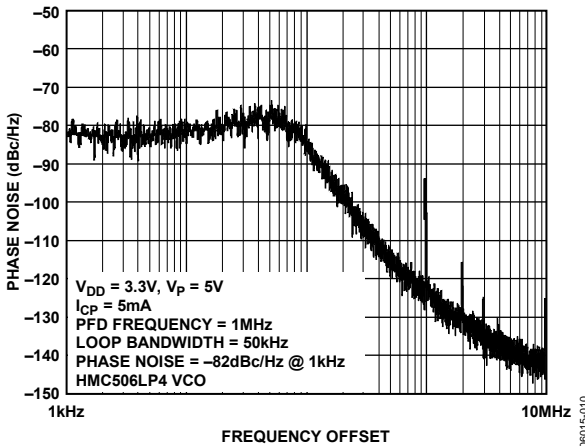

Figure 7. Phase Noise at 7.9 GHz Phase Noise

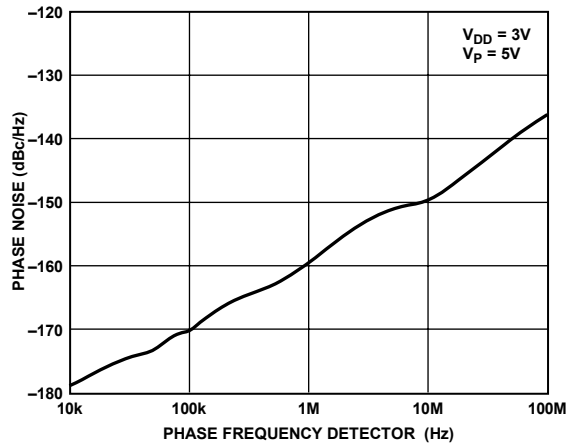

Figure 10. Phase Noise (Referred to CP Output) vs. PFD Frequency



## THEORY OF OPERATION

### REFERENCE INPUT STAGE

The reference input stage is shown in Figure 11. SW1 and SW2 are normally closed switches. SW3 is normally open. When power-down is initiated, SW3 is closed and SW1 and SW2 are opened. This ensures that there is no loading of the REF<sub>IN</sub> pin on power-down.

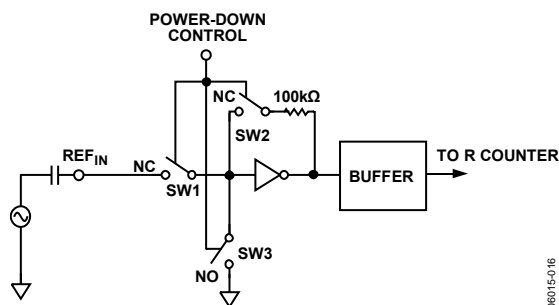

Figure 11. Reference Input Stage

### RF INPUT STAGE

The RF input stage is shown in Figure 12. It is followed by a 2-stage limiting amplifier to generate the CML clock levels needed for the prescaler.

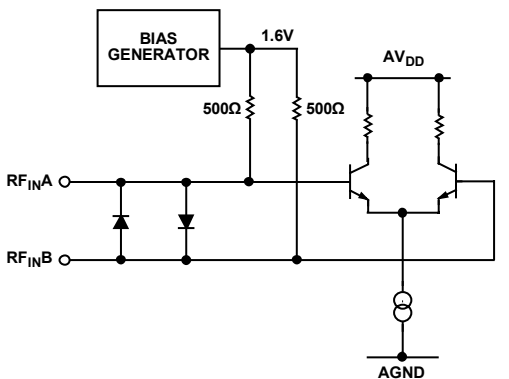

Figure 12. RF Input Stage

### PRESCALER (P/P + 1)

The dual-modulus prescaler (P/P + 1), along with the A and B counters, enables the large division ratio, N, to be realized (N = BP + A). The dual-modulus prescaler, operating at CML levels, takes the clock from the RF input stage and divides it down to a manageable frequency for the CMOS A and B counters. The prescaler is programmable. It can be set in software to 8/9, 16/17, 32/33, or 64/65. It is based on a synchronous 4/5 core. A minimum divide ratio is possible for contiguous output frequencies. This minimum is determined by P, the prescaler value, and is given by: (P<sup>2</sup> - P).

### A AND B COUNTERS

The A and B CMOS counters combine with the dual-modulus prescaler to allow a wide ranging division ratio in the PLL

feedback counter. The counters are specified to work when the prescaler output is 300 MHz or less. Thus, with an RF input frequency of 4.0 GHz, a prescaler value of 16/17 is valid but a value of 8/9 is not valid.

### Pulse Swallow Function

The A and B counters, in conjunction with the dual-modulus prescaler, make it possible to generate output frequencies that are spaced only by the reference frequency divided by R. The equation for the VCO frequency is as follows:

$$f_{VCO} = [(P \times B) + A] \times \frac{f_{REFIN}}{R}$$

where:

$f_{VCO}$  is the output frequency of external voltage controlled oscillator (VCO).

P is the preset modulus of dual-modulus prescaler (8/9, 16/17, and so on.).

B is the preset divide ratio of binary 13-bit counter (3 to 8191).

A is the preset divide ratio of binary 6-bit swallow counter (0 to 63).

$f_{REFIN}$  is the external reference frequency oscillator.

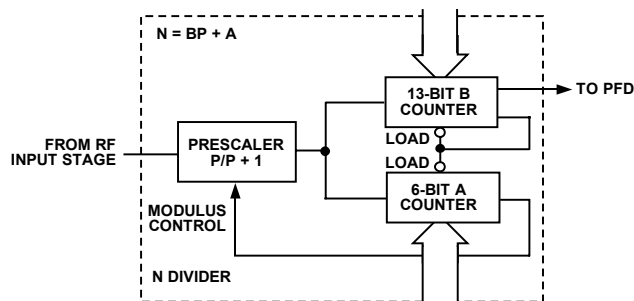

Figure 13. A and B Counters

### R COUNTER

The 14-bit R counter allows the input reference frequency to be divided down to produce the reference clock to the phase frequency detector (PFD). Division ratios from 1 to 16,383 are allowed.

### PHASE FREQUENCY DETECTOR AND CHARGE PUMP

The phase frequency detector (PFD) takes inputs from the R counter and N counter (N = BP + A) and produces an output proportional to the phase and frequency difference between them. Figure 14 is a simplified schematic. The PFD includes a programmable delay element that controls the width of the antibacklash pulse. This pulse ensures that there is no dead zone in the PFD transfer function and minimizes phase noise and reference spurs. Two bits in the reference counter latch, ABP2 and ABP1, control the width of the pulse. (See Figure 17.)

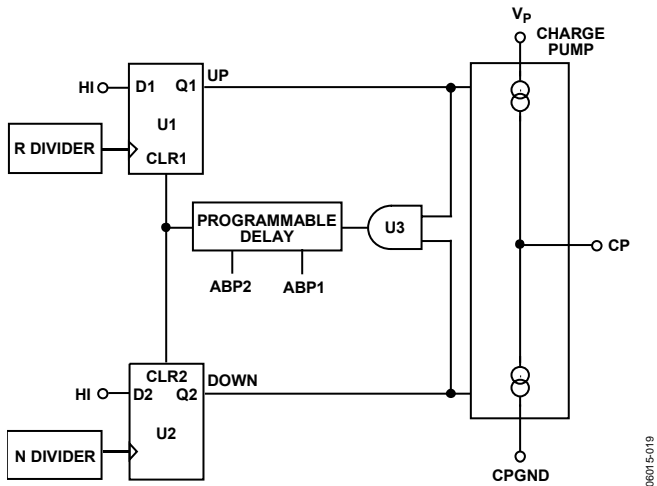

Figure 14. PFD Simplified Schematic and Timing (in Lock)

## MUXOUT AND LOCK DETECT

The output multiplexer on the ADF4108 allows the user to access various internal points on the chip. The state of MUXOUT is controlled by M3, M2, and M1 in the function latch. Figure 19 shows the full truth table. Figure 15 shows the MUXOUT section in block diagram form.

### Lock Detect

MUXOUT can be programmed for two types of lock detect: digital lock detect and analog lock detect.

Digital lock detect is active high. When the lock detect precision (LDP) bit in the R counter latch is set to 0, digital lock detect is set high when the phase error on three consecutive phase detector (PD) cycles is less than 15 ns. With LDP set to 1, five consecutive cycles of less than 15 ns are required to set the lock detect. It will stay set high until a phase error of greater than 25 ns is detected on any subsequent PD cycle.

The N-channel open-drain analog lock detect should be operated with an external pull-up resistor of 10 kΩ nominal. When lock has been detected, this output will be high with narrow, low-going pulses.

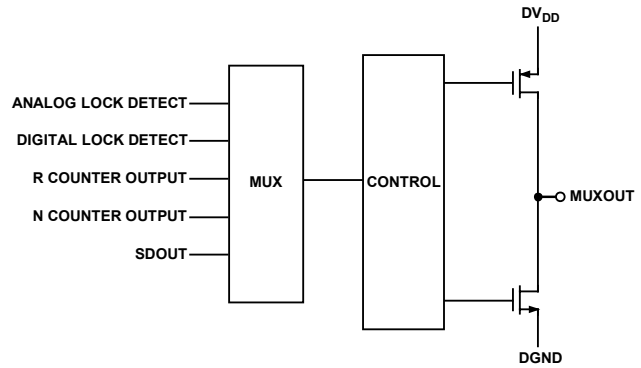

Figure 15. MUXOUT Circuit

## INPUT SHIFT REGISTER

The ADF4108 digital section includes a 24-bit input shift register, a 14-bit R counter, and a 19-bit N counter, comprising a 6-bit A counter and a 13-bit B counter. Data is clocked into the 24-bit shift register on each rising edge of CLK. The data is clocked in MSB first. Data is transferred from the shift register to one of four latches on the rising edge of LE. The destination latch is determined by the state of the two control bits (C2, C1) in the shift register. These are the 2 LSBs, DB1 and DB0, as shown in the timing diagram of Figure 2. The truth table for these bits is shown in Table 5.

Figure 16 shows a summary of how the latches are programmed.

Table 5. C2 and C1 Truth Table

Control Bits		Data Latch
C2	C1	
0	0	R counter
0	1	N counter (A and B)
1	0	Function latch (Including prescaler)
1	1	Initialization latch

LATCH SUMMARY

REFERENCE COUNTER LATCH

RESERVED			LOCK DETECT PRECISION	TEST MODE BITS			ANTI- BACKLASH WIDTH		14-BIT REFERENCE COUNTER												CONTROL BITS		
DB23	DB22	DB21		DB20	DB19	DB18	DB17	DB16	DB15	DB14	DB13	DB12	DB11	DB10	DB9	DB8	DB7	DB6	DB5	DB4	DB3	DB2	DB1
X	0	0	LDP	T2	T1	ABP2	ABP1	R14	R13	R12	R11	R10	R9	R8	R7	R6	R5	R4	R3	R2	R1	C2 (0)	C1 (0)

N COUNTER LATCH

RESERVED			CP GAIN	13-BIT B COUNTER												6-BIT A COUNTER						CONTROL BITS	
DB23	DB22	DB21		DB20	DB19	DB18	DB17	DB16	DB15	DB14	DB13	DB12	DB11	DB10	DB9	DB8	DB7	DB6	DB5	DB4	DB3	DB2	DB1
X	X	G1	B13	B12	B11	B10	B9	B8	B7	B6	B5	B4	B3	B2	B1	A6	A5	A4	A3	A2	A1	C2 (0)	C1 (1)

FUNCTION LATCH

PRESCALER VALUE		POWER- DOWN 2	CURRENT SETTING 2			CURRENT SETTING 1			TIMER COUNTER CONTROL				FASTLOCK MODE	FASTLOCK ENABLE	CP THREE- STATE	PD POLARITY	MUXOUT CONTROL			POWER- DOWN 1	COUNTER RESET	CONTROL BITS	
DB23	DB22		DB21	DB20	DB19	DB18	DB17	DB16	DB15	DB14	DB13	DB12					DB11	DB10	DB9			DB8	DB7
P2	P1	PD2	CPI6	CPI5	CPI4	CPI3	CPI2	CPI1	TC4	TC3	TC2	TC1	F5	F4	F3	F2	M3	M2	M1	PD1	F1	C2 (1)	C1 (0)

INITIALIZATION LATCH

PRESCALER VALUE		POWER- DOWN 2	CURRENT SETTING 2			CURRENT SETTING 1			TIMER COUNTER CONTROL				FASTLOCK MODE	FASTLOCK ENABLE	CP THREE- STATE	PD POLARITY	MUXOUT CONTROL			POWER- DOWN 1	COUNTER RESET	CONTROL BITS	
DB23	DB22		DB21	DB20	DB19	DB18	DB17	DB16	DB15	DB14	DB13	DB12					DB11	DB10	DB9			DB8	DB7
P2	P1	PD2	CPI6	CPI5	CPI4	CPI3	CPI2	CPI1	TC4	TC3	TC2	TC1	F5	F4	F3	F2	M3	M2	M1	PD1	F1	C2 (1)	C1 (1)

Figure 16. Latch Summary

08015-021

## REFERENCE COUNTER LATCH MAP

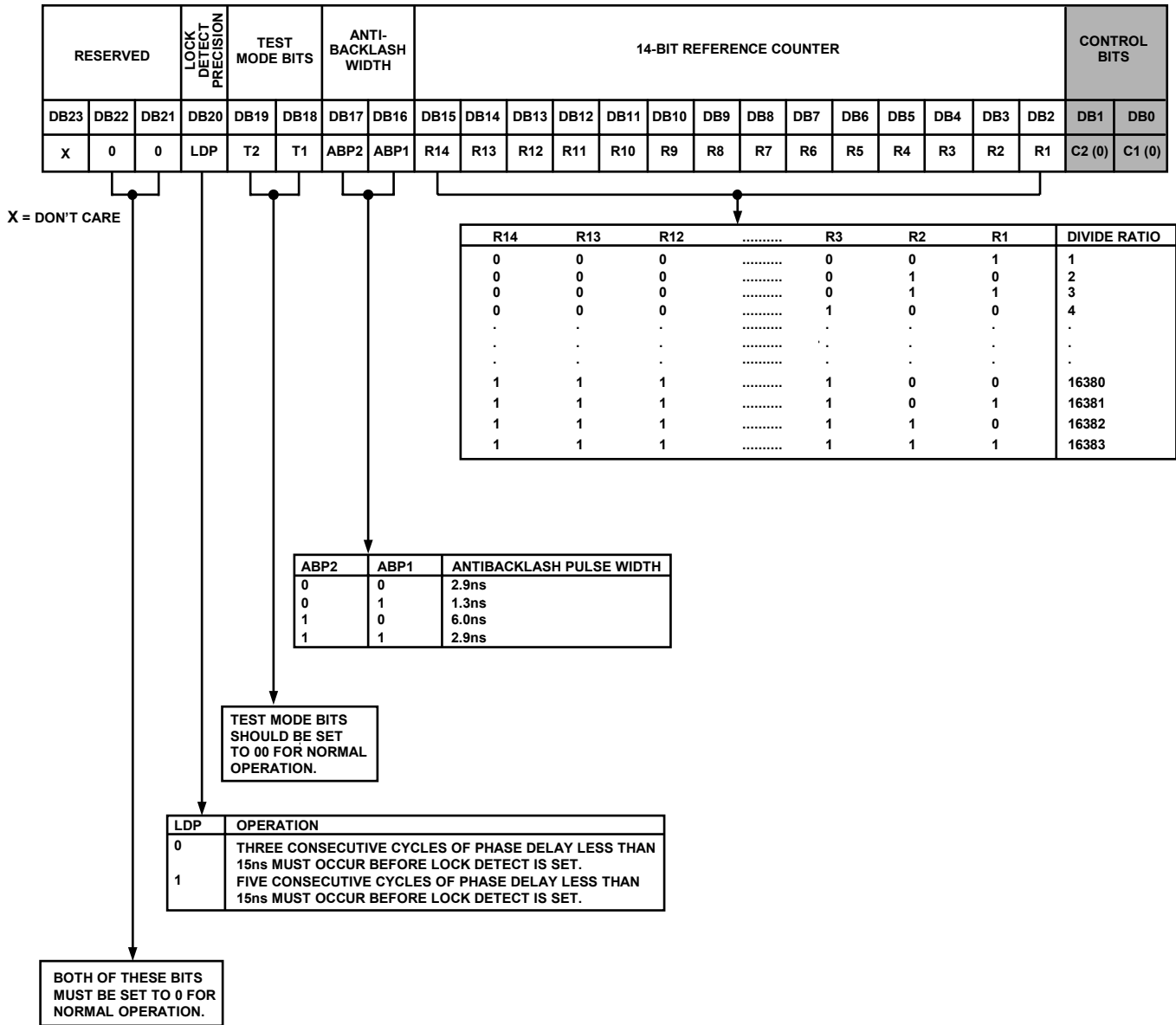

Figure 17. Reference Counter Latch Map

AB COUNTER LATCH MAP

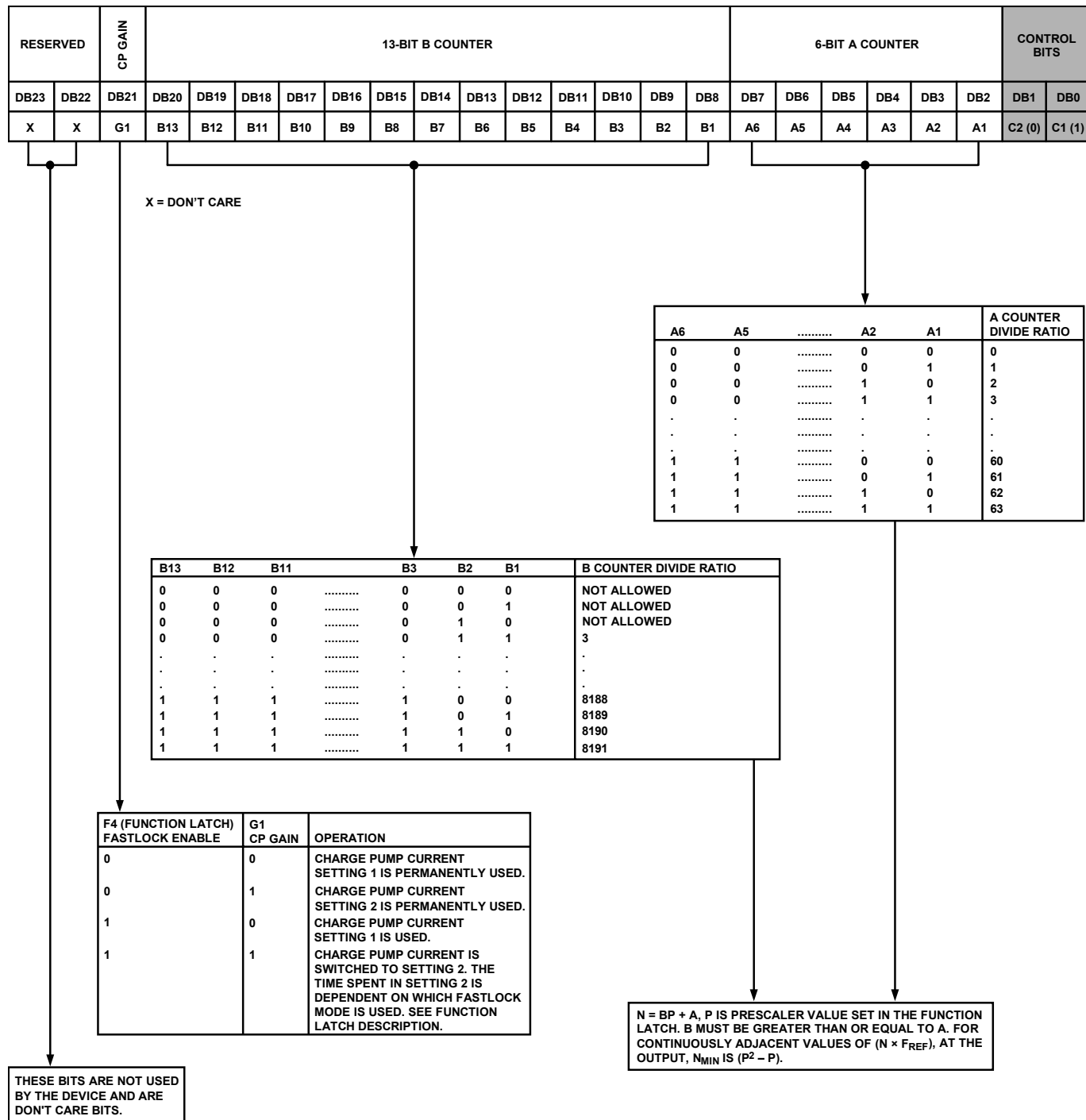

Figure 18. AB Counter Latch Map

06015-023

## FUNCTION LATCH MAP

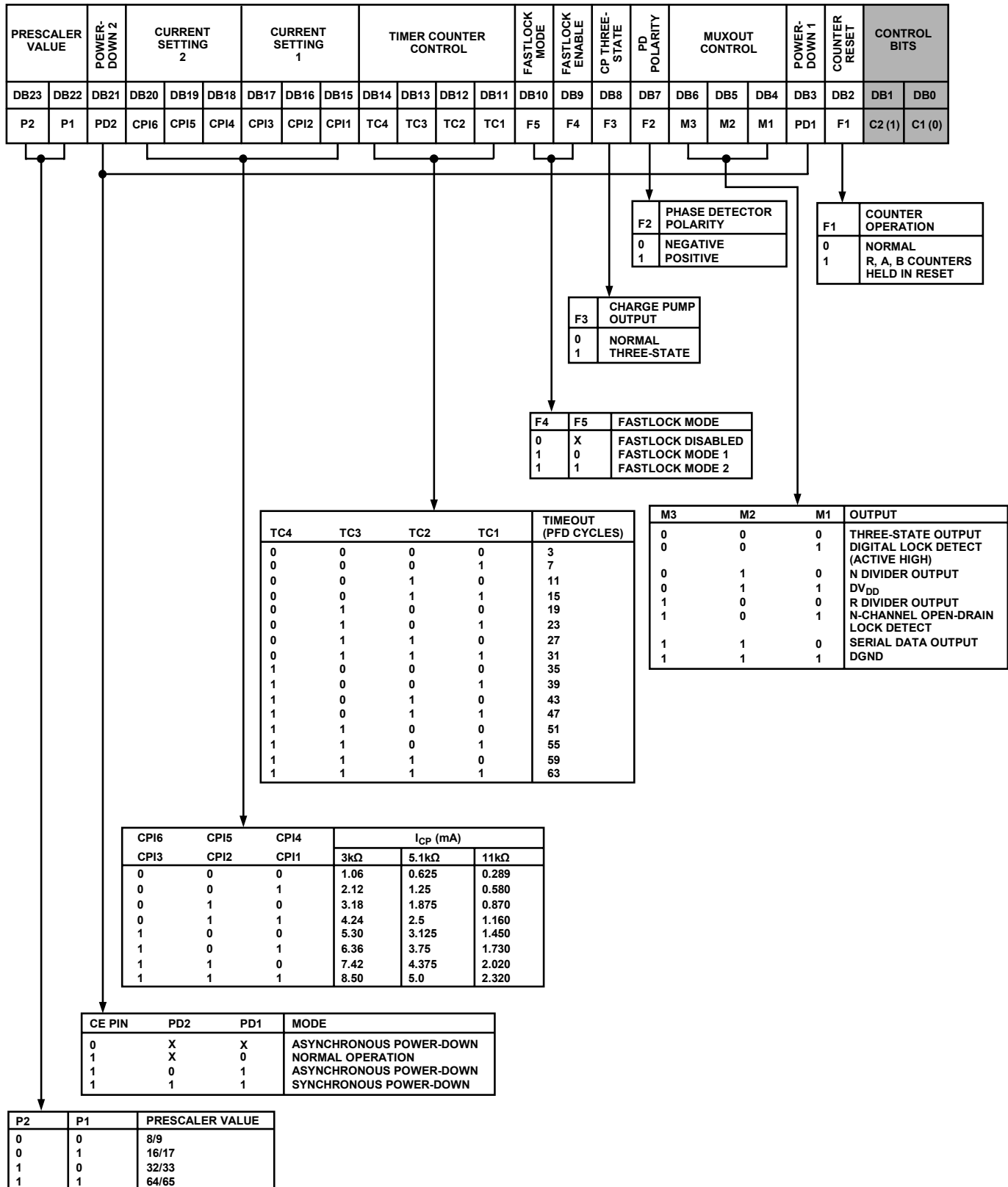

Figure 19. Function Latch Map

INITIALIZATION LATCH MAP

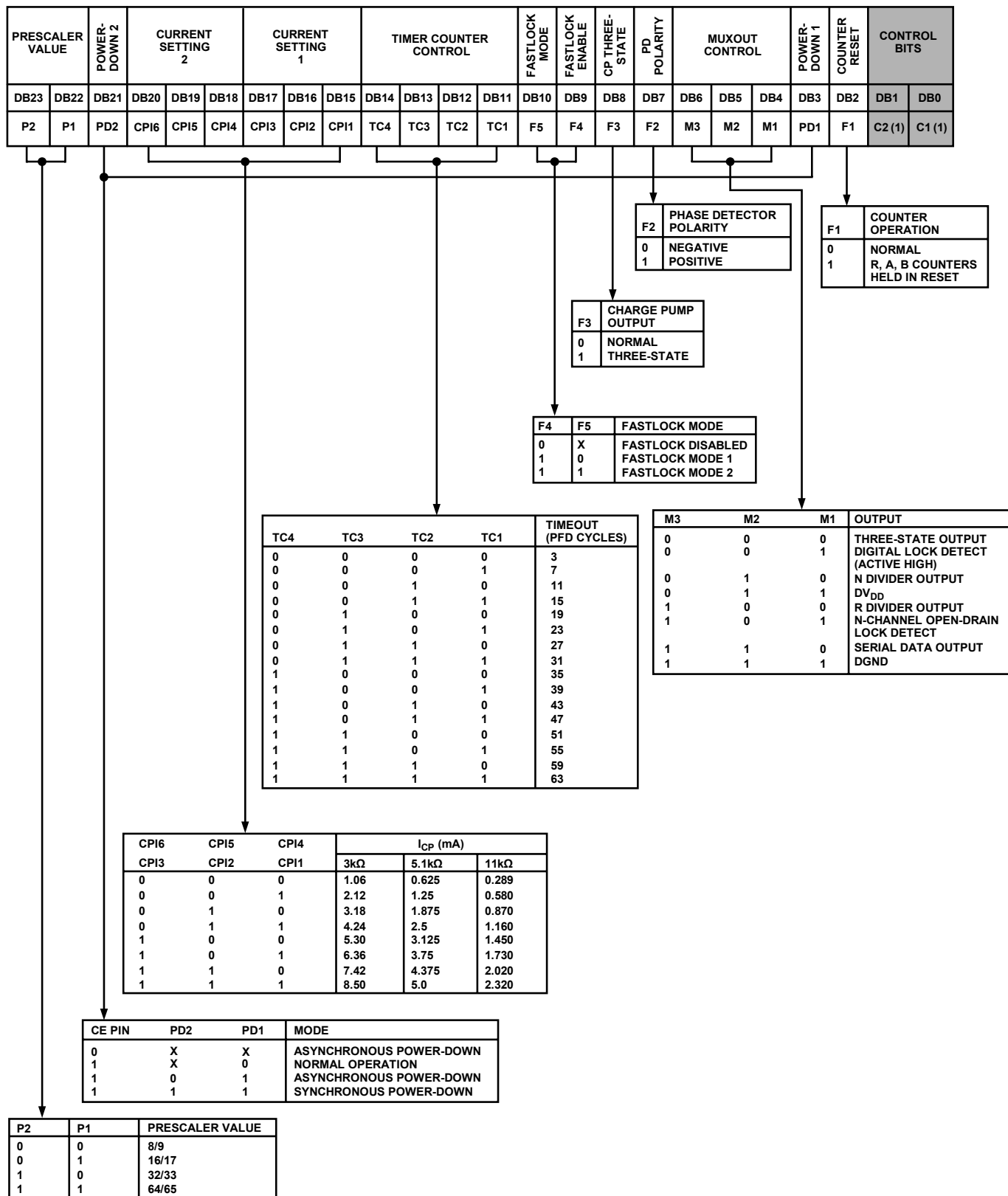

Figure 20. Initialization Latch Map

## FUNCTION LATCH

The on-chip function latch is programmed with C2 and C1 set to 1 and 0, respectively. Figure 19 shows the input data format for programming the function latch.

### Counter Reset

DB2 (F1) is the counter reset bit. When this bit is 1, the R counter and the AB counters are reset. For normal operation, this bit should be 0. Upon powering up, the F1 bit needs to be disabled (set to 0). Then, the N counter resumes counting in close alignment with the R counter. (The maximum error is one prescaler cycle.)

### Power-Down

DB3 (PD1) and DB21 (PD2) provide programmable power-down modes. They are enabled by the CE pin.

When the CE pin is low, the device is immediately disabled regardless of the states of PD2 and PD1.

In the programmed asynchronous power-down, the device powers down immediately after latching a 1 into the PD1 bit, with the condition that PD2 has been loaded with a 0.

In the programmed synchronous power-down, the device power-down is gated by the charge pump to prevent unwanted frequency jumps. Once the power-down is enabled by writing a 1 into PD1 (on condition that a 1 has also been loaded to PD2), then the device will go into power-down on the occurrence of the next charge pump event.

When a power-down is activated (either synchronous or asynchronous mode, including CE pin activated power-down), the following events occur:

- All active dc current paths are removed.
- The R, N, and timeout counters are forced to their load state conditions.
- The charge pump is forced into three-state mode.
- The digital lock detect circuitry is reset.
- The RF<sub>IN</sub> input is debiased.
- The reference input buffer circuitry is disabled.
- The input register remains active and capable of loading and latching data.

### MUXOUT Control

The on-chip multiplexer is controlled by M3, M2, and M1 on the ADF4108. Figure 19 shows the truth table.

### Fastlock Enable Bit

DB9 of the function latch is the fastlock enable bit. Fastlock is enabled only when this bit is 1.

### Fastlock Mode Bit

DB10 of the function latch is the fastlock mode bit. When

fastlock is enabled, this bit determines which fastlock mode is used. If the fastlock mode bit is 0, then Fastlock Mode 1 is selected; and if the fastlock mode bit is 1, then Fastlock Mode 2 is selected.

### Fastlock Mode 1

The charge pump current is switched to the contents of Current Setting 2.

The device enters fastlock by having a 1 written to the CP gain bit in the AB counter latch. The device exits fastlock by having a 0 written to the CP gain bit in the AB counter latch.

### Fastlock Mode 2

The charge pump current is switched to the contents of Current Setting 2.

The device enters fastlock by having a 1 written to the CP gain bit in the AB counter latch. The device exits fastlock under the control of the timer counter. After the timeout period determined by the value in TC4:TC1, the CP gain bit in the AB counter latch is automatically reset to 0 and the device reverts to normal mode instead of fastlock. See Figure 19 for the timeout periods.

### Timer Counter Control

The user has the option of programming two charge pump currents. The intent is that Current Setting 1 is used when the RF output is stable and the system is in a static state. Current Setting 2 is meant to be used when the system is dynamic and in a state of change (that is, when a new output frequency is programmed).

The normal sequence of events is as follows:

The user initially decides what the preferred charge pump currents are going to be. For example, the choice may be 2.5 mA as Current Setting 1 and 5 mA as Current Setting 2.

At the same time it must be decided how long the secondary current is to stay active before reverting to the primary current. This is controlled by the timer counter control bits, DB14:DB11 (TC4:TC1) in the function latch. The truth table is given in Figure 19.

Now, to program a new output frequency, the user simply programs the AB counter latch with new values for A and B. At the same time, the CP gain bit can be set to 1, which sets the charge pump with the value in CPI6:CPI4 for a period of time determined by TC4–TC1. When this time is up, the charge pump current reverts to the value set by CPI3:CPI1. At the same time, the CP gain bit in the AB counter latch is reset to 0 and is now ready for the next time the user wishes to change the frequency.

Note that there is an enable feature on the timer counter. It is enabled when Fastlock Mode 2 is chosen by setting the fastlock mode bit (DB10) in the function latch to 1.



### Charge Pump Currents

CPI3, CPI2, and CPI1 program Current Setting 1 for the charge pump. CPI6, CPI5, and CPI4 program Current Setting 2 for the charge pump. The truth table is given in Figure 19.

### Prescaler Value

P2 and P1 in the function latch set the prescaler values. The prescaler value should be chosen so that the prescaler output frequency is always less than or equal to 300 MHz. Thus, with an RF frequency of 4 GHz, a prescaler value of 16/17 is valid but a value of 8/9 is not valid.

### PD Polarity

This bit sets the phase detector polarity bit. See Figure 19.

### CP Three-State

This bit controls the CP output pin. With the bit set high, the CP output is put into three-state. With the bit set low, the CP output is enabled.

## INITIALIZATION LATCH

The initialization latch is programmed when C2 and C1 are set to 1 and 1. This is essentially the same as the function latch (programmed when C2, C1 = 1, 0).

However, when the initialization latch is programmed, an additional internal reset pulse is applied to the R and AB counters. This pulse ensures that the AB counter is at load point when the AB counter data is latched and the device will begin counting in close phase alignment.

If the latch is programmed for synchronous power-down (CE pin is high; PD1 bit is high; PD2 bit is low), the internal pulse also triggers this power-down. The prescaler reference and the oscillator input buffer are unaffected by the internal reset pulse and so close phase alignment is maintained when counting resumes.

When the first AB counter data is latched after initialization, the internal reset pulse is again activated. However, successive AB counter loads after this will not trigger the internal reset pulse.

### Device Programming after Initial Power-Up

After initially powering up the device, there are three ways to program the device.

#### Initialization Latch Method

1. Apply  $V_{DD}$ .
2. Program the initialization latch (11 in 2 LSBs of input word). Make sure that the F1 bit is programmed to 0.
3. Next, do a function latch load (10 in 2 LSBs of the control word), making sure that the F1 bit is programmed to a 0.
4. Then do an R load (00 in 2 LSBs).
5. Then do an AB load (01 in 2 LSBs).

When the initialization latch is loaded, the following occurs:

- The function latch contents are loaded.
- An internal pulse resets the R, AB, and timeout counters to load-state conditions and also three-states the charge pump. Note that the prescaler band gap reference and the oscillator input buffer are unaffected by the internal reset pulse, allowing close phase alignment when counting resumes.
- Latching the first AB counter data after the initialization word will activate the same internal reset pulse. Successive AB loads will not trigger the internal reset pulse unless there is another initialization.

#### CE Pin Method

1. Apply  $V_{DD}$ .
2. Bring CE low to put the device into power-down. This is an asynchronous power-down in that it happens immediately.
3. Program the function latch (10).
4. Program the R counter latch (00).
5. Program the AB counter latch (01).
6. Bring CE high to take the device out of power-down. The R and AB counters will now resume counting in close alignment.

Note that after CE goes high, a duration of 1  $\mu$ s may be required for the prescaler band gap voltage and oscillator input buffer bias to reach steady state.

CE can be used to power the device up and down to check for channel activity. The input register does not need to be reprogrammed each time the device is disabled and enabled as long as it has been programmed at least once after  $V_{DD}$  was initially applied.

#### Counter Reset Method

1. Apply  $V_{DD}$ .
2. Do a function latch load (10 in 2 LSBs). As part of this, load 1 to the F1 bit. This enables the counter reset.
3. Do an R counter load (00 in 2 LSBs).
4. Do an AB counter load (01 in 2 LSBs).
5. Do a function latch load (10 in 2 LSBs). As part of this, load 0 to the F1 bit. This disables the counter reset.

This sequence provides the same close alignment as the initialization method. It offers direct control over the internal reset. Note that counter reset holds the counters at load point and three-states the charge pump, but does not trigger synchronous power-down.

## POWER SUPPLY CONSIDERATIONS

The ADF4108 operates over a power supply range of 3.2 V to 3.6 V. The ADP3300ART-3.3 is a low dropout linear regulator from Analog Devices. It outputs 3.3 V with an accuracy of 1.4% and is recommended for use with the ADF4108.

# ADF4108

## INTERFACING

The ADF4108 has a simple SPI™-compatible serial interface for writing to the device. CLK, DATA, and LE control the data transfer. When LE (Latch Enable) goes high, the 24 bits that have been clocked into the input register on each rising edge of CLK are transferred to the appropriate latch. See Figure 2 for the timing diagram and Table 5 for the latch truth table.

The maximum allowable serial clock rate is 20 MHz. This means that the maximum update rate possible for the device is 833 kHz or one update every 1.2 μs. This is certainly more than adequate for systems that have typical lock times in hundreds of microseconds.

### ADuC812 INTERFACE

Figure 21 shows the interface between the ADF4108 and the ADuC812 MicroConverter®. Since the ADuC812 is based on an 8051 core, this interface can be used with any 8051 based microcontroller. The MicroConverter is set up for SPI master mode with CPHA = 0. To initiate the operation, the I/O port driving LE is brought low. Each latch of the ADF4108 needs a 24-bit word. This is accomplished by writing three 8-bit bytes from the MicroConverter to the device. When the third byte has been written, the LE input should be brought high to complete the transfer.

On first applying power to the ADF4108, it needs four writes (one each to the initialization latch, function latch, R counter latch, and N counter latch) for the output to become active.

I/O port lines on the ADuC812 are also used to control power-down (CE input) and to detect lock (MUXOUT configured as lock detect and polled by the port input).

When operating in the mode described, the maximum SCLOCK rate of the ADuC812 is 4 MHz. This means that the maximum rate at which the output frequency can be changed will be 166 kHz.

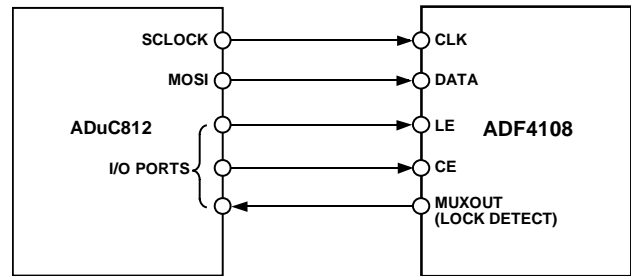

Figure 21. ADuC812 to ADF4108 Interface

### ADSP-2181 INTERFACE

Figure 22 shows the interface between the ADF4108 and the ADSP-21xx Digital Signal Processor. The ADF4108 needs a 24-bit serial word for each latch write. The easiest way to accomplish this using the ADSP21xx family is to use the autobuffered transmit mode of operation with alternate framing. This provides a means for transmitting an entire block of serial data before an interrupt is generated. Set up the word length for 8 bits and use three memory locations for each 24-bit word. To program each 24-bit latch, store the three 8-bit bytes, enable the autobuffered mode, and then write to the transmit register of the DSP. This last operation initiates the autobuffer transfer.

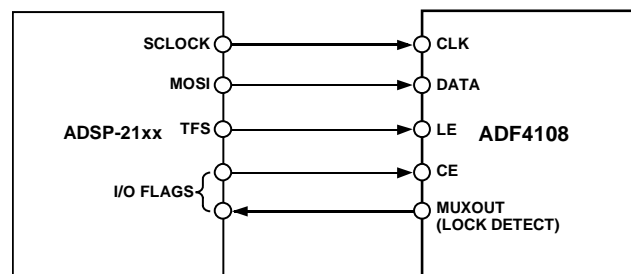

Figure 22. ADSP-21xx to ADF4108 Interface

## PCB DESIGN GUIDELINES FOR CHIP SCALE PACKAGE

The lands on the chip scale package (CP-20) are rectangular. The printed circuit board pad for these should be 0.1 mm longer than the package land length and 0.05 mm wider than the package land width. The land should be centered on the pad. This will ensure that the solder joint size is maximized. The bottom of the chip scale package has a central thermal pad.

The thermal pad on the printed circuit board should be at least as large as this exposed pad. On the printed circuit board, there should be a clearance of at least 0.25 mm between the thermal pad and the inner edges of the pad pattern. This will ensure that shorting is avoided.

Thermal vias can be used on the printed circuit board thermal pad to improve thermal performance of the package. If vias are used, they should be incorporated in the thermal pad at 1.2 mm pitch grid. The via diameter should be between 0.3 mm and 0.33 mm and the via barrel should be plated with 1 oz. copper to plug the via.

The user should connect the printed circuit board thermal pad to AGND.

## OUTLINE DIMENSIONS

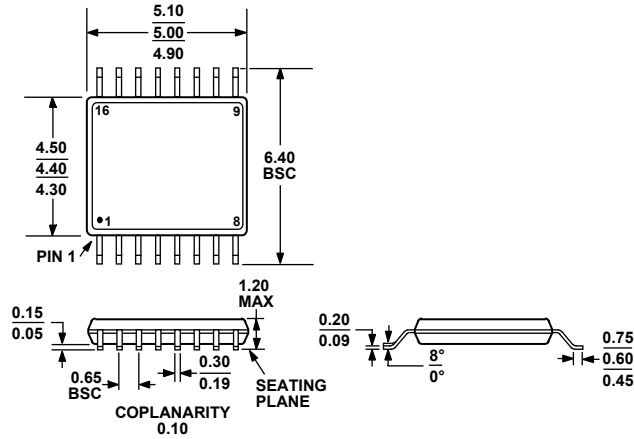

COMPLIANT TO JEDEC STANDARDS MO-153-AB

Figure 23. 16-Lead Thin Shrink Small Outline Package [TSSOP] (RU-16)

Dimensions shown in millimeters

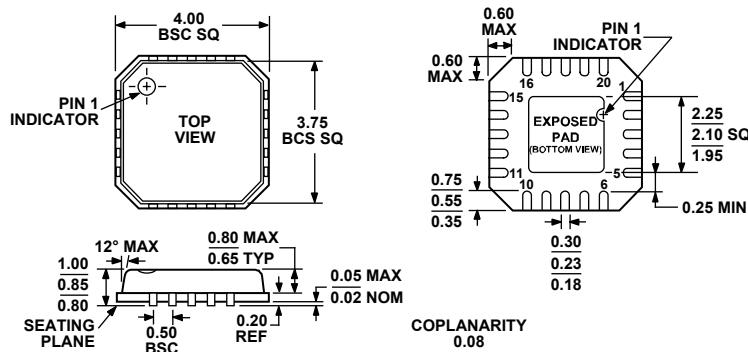

COMPLIANT TO JEDEC STANDARDS MO-220-VGGD-1

Figure 24. 20-Lead Lead Frame Chip Scale Package [LFCSP\_VQ] 4 mm x 4 mm Body, Very Thin Quad (CP-20-1)

Dimensions shown in millimeters

## ORDERING GUIDE

Model	Temperature Range	Package Description	Package Option
ADF4108BRUZ <sup>1</sup>	-40°C to +85°C	16-Lead Thin Shrink Small Outline Package [TSSOP]	RU-16
ADF4108BRUZ-RL <sup>1</sup>	-40°C to +85°C	16-Lead Thin Shrink Small Outline Package [TSSOP]	RU-16
ADF4108BRUZ-RL7 <sup>1</sup>	-40°C to +85°C	16-Lead Thin Shrink Small Outline Package [TSSOP]	RU-16
ADF4108BCPZ <sup>1</sup>	-40°C to +85°C	20-Lead Lead Frame Chip Scale Package [LFCSP_VQ]	CP-20-1
ADF4108BCPZ-RL <sup>1</sup>	-40°C to +85°C	20-Lead Lead Frame Chip Scale Package [LFCSP_VQ]	CP-20-1
ADF4108BCPZ-RL7 <sup>1</sup>	-40°C to +85°C	20-Lead Lead Frame Chip Scale Package [LFCSP_VQ]	CP-20-1
EVAL-ADF4108EB1		Evaluation Board	

<sup>1</sup> Z = Pb-free part.



**Стандарт  
Электрон  
Связь**

Мы молодая и активно развивающаяся компания в области поставок электронных компонентов. Мы поставляем электронные компоненты отечественного и импортного производства напрямую от производителей и с крупнейших складов мира.

Благодаря сотрудничеству с мировыми поставщиками мы осуществляем комплексные и плановые поставки широчайшего спектра электронных компонентов.

Собственная эффективная логистика и склад в обеспечивает надежную поставку продукции в точно указанные сроки по всей России.

Мы осуществляем техническую поддержку нашим клиентам и предпродажную проверку качества продукции. На все поставляемые продукты мы предоставляем гарантию .

Осуществляем поставки продукции под контролем ВП МО РФ на предприятия военно-промышленного комплекса России , а также работаем в рамках 275 ФЗ с открытием отдельных счетов в уполномоченном банке. Система менеджмента качества компании соответствует требованиям ГОСТ ISO 9001.

Минимальные сроки поставки, гибкие цены, неограниченный ассортимент и индивидуальный подход к клиентам являются основой для выстраивания долгосрочного и эффективного сотрудничества с предприятиями радиоэлектронной промышленности, предприятиями ВПК и научно-исследовательскими институтами России.

С нами вы становитесь еще успешнее!

**Наши контакты:**

**Телефон:** +7 812 627 14 35

**Электронная почта:** [sales@st-electron.ru](mailto:sales@st-electron.ru)

**Адрес:** 198099, Санкт-Петербург,  
Промышленная ул, дом № 19, литера Н,  
помещение 100-Н Офис 331