



Wireless Power Transfer

Tx (transmitting) coil units (WPC compliant)

WT505090-20K2-A10-G

Wireless Power Transfer

Product compatible with RoHS directive
Halogen-free

Tx (transmitting) coil units (WPC compliant)

Overview of WT505090-20K2-A10-G

FEATURES

- Tx coil units for WPC low-power (5W) specification.
- Got WPC approval for ferrite sheet.
- Thinner flexible ferrite sheet type is available for durable construction.
- Performance had been confirmed based on WPC equipments.

APPLICATION

Various types of battery chargers (WPC compliant)

SHAPE & DIMENSIONS

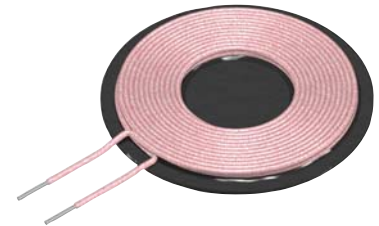
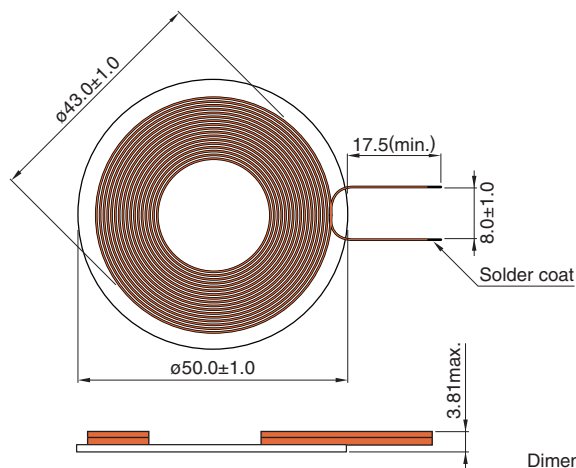

Magnet (mm)	Sheet size (mm)	Coil turns	Coil outer size (mm)typ.
Nothing	ø50	10ts x 2layers 20Ts	ø43

ELECTRICAL CHARACTERISTICS

CHARACTERISTICS SPECIFICATION TABLES

WPC compliant	Input voltage (V)	Inductance [100kHz, 1Vrms] (μH)	DC resistance [25°C] (Ω)max.	Ferrite type	Part No.
WPC A10	19(A10)	24	0.10	Flexible	WT505090-20K2-A10-G

IC REFERENCE INFORMATION

IC	Manufacturer material name	Web
Please contact us.		

- RoHS Directive Compliant Product: See the following for more details. <https://product.tdk.com/info/en/environment/rohs/index.html>
- Halogen-free: Indicates that Cl content is less than 900ppm, Br content is less than 900ppm, and that the total Cl and Br content is less than 1500ppm.

⚠ Please be sure to request delivery specifications that provide further details on the features and specifications of the products for proper and safe use.
Please note that the contents may change without any prior notice due to reasons such as upgrading.

⚠ Reminders

- Do not use or store in locations where there are conditions such as gas corrosion (salt, acid, alkali, etc.).
- Self heating (temperature increase) occurs when the power is turned ON, so the tolerance should be sufficient for the set thermal design.
- Fully caution, if metal piece contacted with top of coil surface then it could be danger of generated heat.
- Do not use for a purpose outside of the contents regulated in the delivery specifications.
- The products listed on this catalog are intended for use in general electronic equipment (AV equipment, telecommunications equipment, home appliances, amusement equipment, computer equipment, personal equipment, office equipment, measurement equipment, industrial robots) under a normal operation and use condition.

The products are not designed or warranted to meet the requirements of the applications listed below, whose performance and/or quality require a more stringent level of safety or reliability, or whose failure, malfunction or trouble could cause serious damage to society, person or property.

If you intend to use the products in the applications listed below or if you have special requirements exceeding the range or conditions set forth in the each catalog, please contact us.

- | | |
|---|--|
| (1) Aerospace/aviation equipment | (8) Public information-processing equipment |
| (2) Transportation equipment (cars, electric trains, ships, etc.) | (9) Military equipment |
| (3) Medical equipment | (10) Electric heating apparatus, burning equipment |
| (4) Power-generation control equipment | (11) Disaster prevention/crime prevention equipment |
| (5) Atomic energy-related equipment | (12) Safety equipment |
| (6) Seabed equipment | (13) Other applications that are not considered general-purpose applications |
| (7) Transportation control equipment | |



Стандарт Электрон Связь

Мы молодая и активно развивающаяся компания в области поставок электронных компонентов. Мы поставляем электронные компоненты отечественного и импортного производства напрямую от производителей и с крупнейших складов мира.

Благодаря сотрудничеству с мировыми поставщиками мы осуществляем комплексные и плановые поставки широчайшего спектра электронных компонентов.

Собственная эффективная логистика и склад в обеспечивает надежную поставку продукции в точно указанные сроки по всей России.

Мы осуществляем техническую поддержку нашим клиентам и предпродажную проверку качества продукции. На все поставляемые продукты мы предоставляем гарантию .

Осуществляем поставки продукции под контролем ВП МО РФ на предприятия военно-промышленного комплекса России , а также работаем в рамках 275 ФЗ с открытием отдельных счетов в уполномоченном банке. Система менеджмента качества компании соответствует требованиям ГОСТ ISO 9001.

Минимальные сроки поставки, гибкие цены, неограниченный ассортимент и индивидуальный подход к клиентам являются основой для выстраивания долгосрочного и эффективного сотрудничества с предприятиями радиоэлектронной промышленности, предприятиями ВПК и научно-исследовательскими институтами России.

С нами вы становитесь еще успешнее!

Наши контакты:

Телефон: +7 812 627 14 35

Электронная почта: sales@st-electron.ru

Адрес: 198099, Санкт-Петербург,
Промышленная ул, дом № 19, литера Н,
помещение 100-Н Офис 331