

---

## LIN Transceiver with Voltage Regulator

---

### Features

- The MCP2050 is compliant with:
  - LIN Bus Specifications Version 1.3, and 2.x
  - SAE J2602-2
- Support Baud Rates Up to 20 kBaud
- 43V Load Dump Protected
- Maximum Continuous Input Voltage of 30V
- Wide LIN Compliant Supply Voltage, 6.0-18.0V
- Extended Temperature Range: -40 to +125°C
- Interface to PIC® EUSART and Standard USARTs
- Wake-up on LIN Bus Activity or Local Wake Input
- LIN Bus Pin
  - Internal Pull-up Termination Resistor and Diode for Slave Node
  - Protected Against VBAT Shorts
  - Protected Against Loss of Ground
  - High Current Drive
- TXD and LIN Bus Dominant Time-out Function
- Two Low-power Modes
  - TRANSMITTER OFF Mode: 90  $\mu$ A (typical)
  - POWER DOWN Mode: 4.5  $\mu$ A (typical)
- Output Indicating Internal RESET State (POR or SLEEP Wake)
- MCP2050 On-chip Voltage Regulator
  - Output Voltage of 5.0V or 3.3V 70 mA Capability with Tolerances of  $\pm$ 3% Over Temperature Range
  - Internal Short Circuit Current Limit
  - Only External Filter and Load Capacitors Needed
- Programmable Windowed Watchdog Timer (WWDT)
  - External Resistor Programmable from 7 ms to 140 ms
  - Disabled by Connecting the WWDTSELECT Pin to VREG or Let the Pin Float
- Ratiometric Output of VBAT Voltage Scaled to VREG
- Automatic Thermal Shutdown
- High Electromagnetic Immunity (EMI), Low Electromagnetic Emission (EME)
- Robust ESD Performance:  $\pm$ 15 kV for LBUS and VBB pin (IEC61000-4-2)
- Transient Protection for LBUS and VBB Pins in Automotive Environment (ISO7637)
- Meets Stringent Automotive Design Requirements

Including “OEM Hardware Requirements for LIN, CAN and FlexRay Interfaces in Automotive Applications”, Version 1.2, March 2011

- Multiple Package Options Including Small 5x5 QFN

### Description

The MCP2050 provides a bidirectional, half-duplex communication physical interface to meet the LIN bus specification Revision 2.1 and SAE J2602. The device incorporates a voltage regulator with 5V or 3.3V 70 mA regulated power supply output. The on-chip WWDT allows users to adjust the size of the reset window by using an external resistor. The ratiometric VBAT pin scales down VBAT to the range of VREG so it can be monitored by an A/D converter.

The device has been designed to meet the stringent quiescent current requirements of the automotive industry and will survive +43V load dump transients, and double battery jumps.

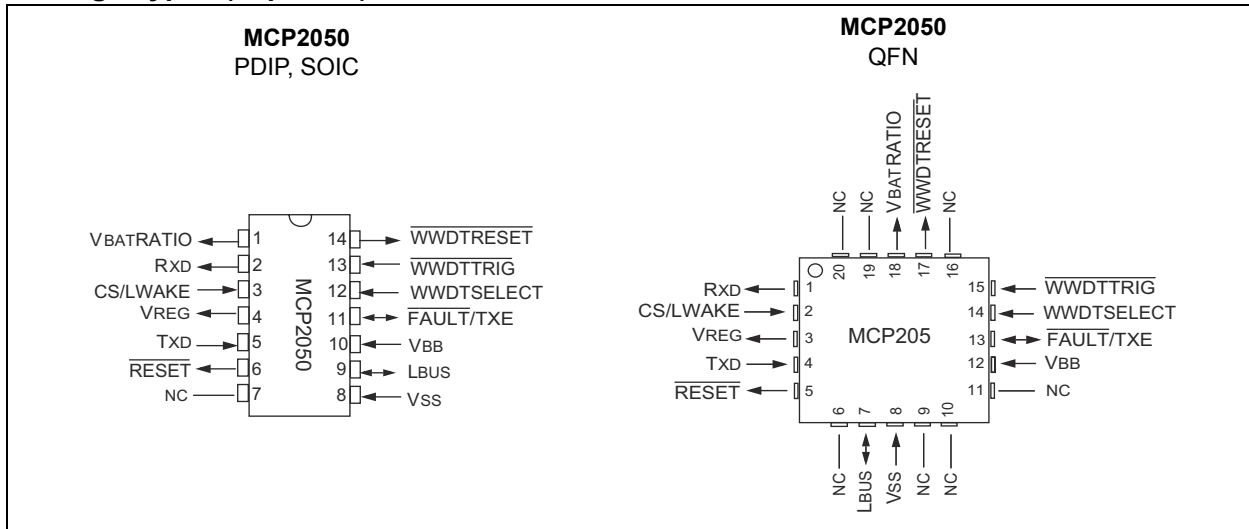
MCP2050 family members:

- MCP2050-500, 14-pin, LIN driver with 5.0V regulator
- MCP2050-330, 14-pin, LIN driver with 3.3V regulator
- MCP2050-500, 20-pin QFN, LIN driver with 5.0V regulator
- MCP2050-330, 20-pin QFN, LIN driver with 3.3V regulator

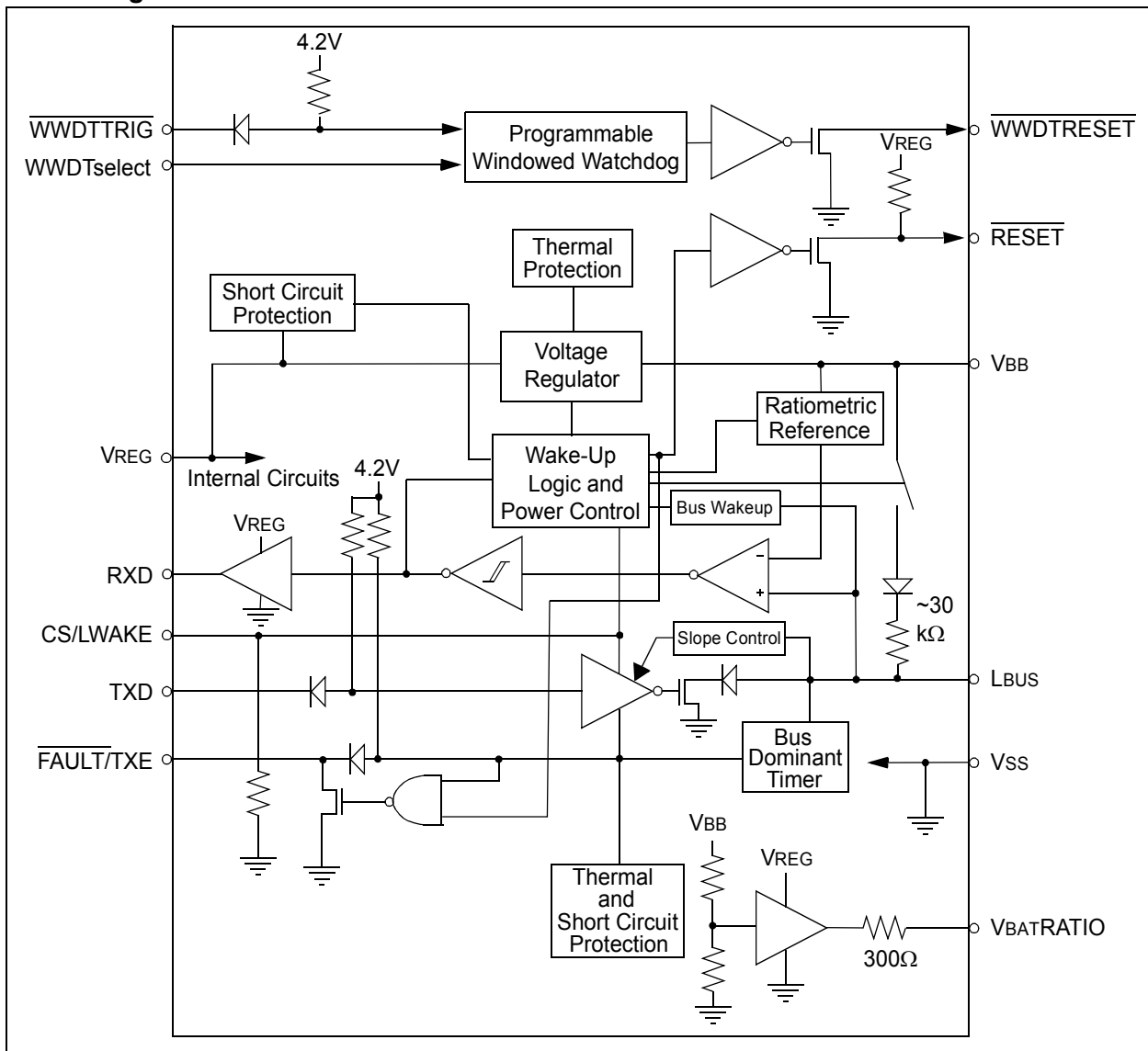


# MCP2050

## Package Types (Top View)



## Block Diagram



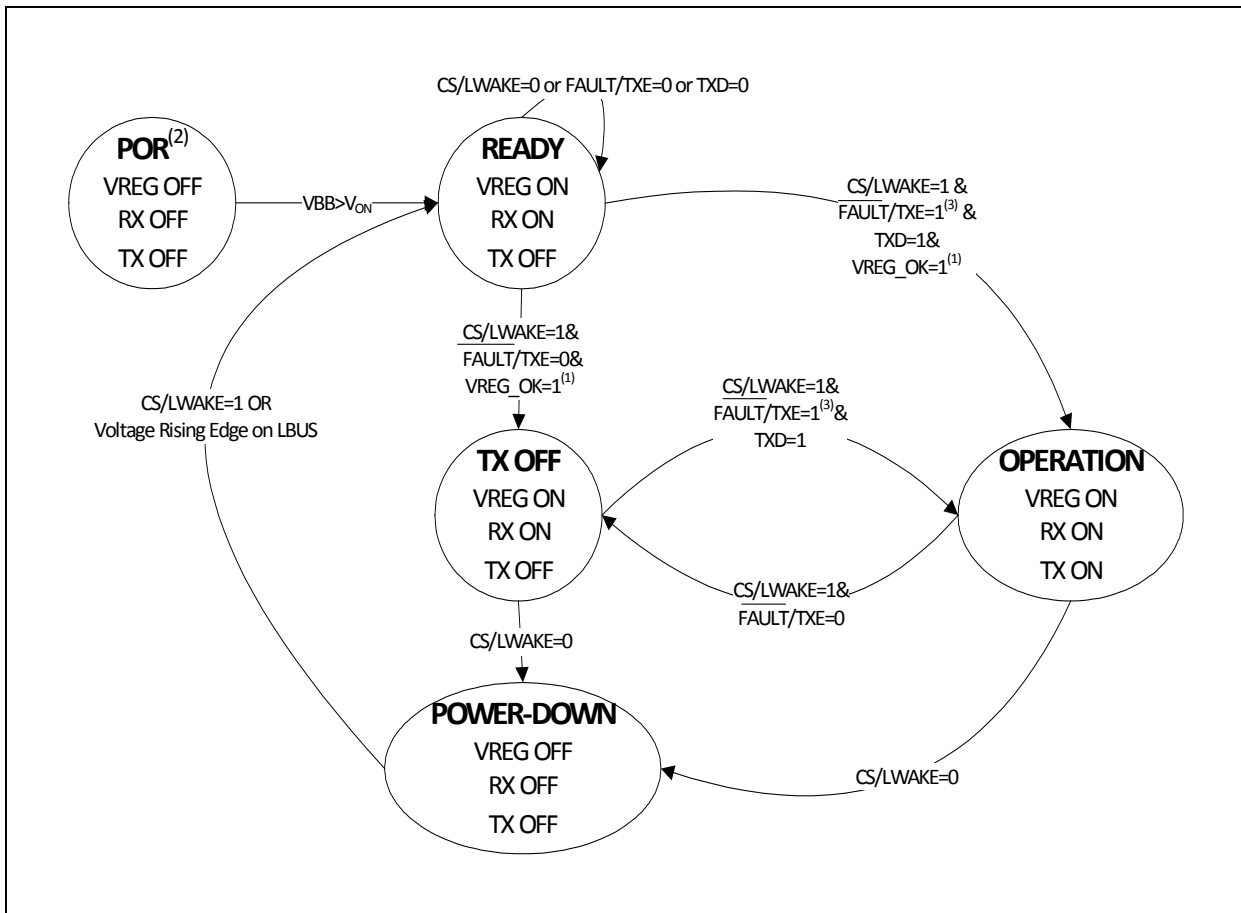
## 1.0 FUNCTION DESCRIPTION

The MCP2050 provides a physical interface between a microcontroller and a LIN half-duplex bus. It is intended for automotive and industrial applications with serial bus baud rates up to 20 kbaud. This device will translate the CMOS/TTL logic levels to LIN logic levels, and vice versa. The device offers optimum EMI and ESD performance; it can withstand high voltage on the LIN bus. The device supports two low-power modes to meet automotive industry power consumption requirements. The MCP2050 also provides a +5V or 3.3V 70 mA regulated power output.

## 1.1 Modes of Operation

The MCP2050 works in five modes: POWER-ON-RESET mode, POWER-DOWN mode, READY mode, OPERATION mode, and TRANSMITTER OFF mode. For an overview of all operational modes, please refer to [Table 1-1](#). For the operational mode transition, please refer to [Figure 1-1](#).

**FIGURE 1-1: STATE DIAGRAM**



**Note 1:** VREG\_OK: Regulator Output Voltage > 0.8V<sub>REG\_NOM</sub>.

**2:** If the voltage on pin VBB falls below V<sub>OFF</sub>, the device will enter POWER ON RESET mode from all other modes, which is not shown in the figure.

**3:** FAULT/TXE = 1 represents input High and no fault conditions. FAULT/TXE = 0 represents input Low or a fault condition. Refer to [Table 1-3](#).

### 1.1.1 POWER-ON-RESET MODE

Upon application of V<sub>BB</sub>, or whenever the voltage on V<sub>BB</sub> is below the threshold of regulator turn off voltage V<sub>OFF</sub> (typically 4.50V), the device enters POWER-ON-RESET mode (POR). During this mode, the device maintains the digital section in a reset mode and waits

until the voltage on pin V<sub>BB</sub> rises above the threshold of regulator turn on voltage V<sub>ON</sub> (typically 5.75V) to enter into READY mode. In POWER-ON-RESET mode, the LIN physical layer and voltage regulator are disabled, and RESET output is forced to LOW.

## 1.1.2 READY MODE

The device enters READY mode from POR mode after the voltage on VBB rises above the threshold of regulator turn on voltage  $V_{ON}$  or from POWER-DOWN mode when a remote or local wake-up event happens.

Upon entering READY mode, the voltage regulator and receiver section of the transceiver are powered up. The transmitter remains in off state. The device is ready to receive data but not to transmit. In order to minimize the power consumption, the regulator operates in a reduced power mode. It has a lower GBW product and thus is slower. However, the 70 mA drive capability is unchanged.

The device stays in READY mode until the output of the voltage regulator has stabilized and the CS/LWAKE pin is HIGH ('1').

## 1.1.3 OPERATION MODE

If VREG is OK ( $V_{REG} > 0.8 V_{REG\_NOM}$ ), CS/LWAKE pin, FAULT/TXE pin and TXD pin are HIGH, the part enters the OPERATION mode from either READY or TRANSMITTER OFF mode.

In this mode, all internal modules are operational. The internal pull-up resistor between LBUS and VBB is connected only in this mode.

The device goes into the POWER-DOWN mode at the falling edge on CS/LWAKE; or to the TRANSMITTER OFF mode at the falling on FAULT/TXE while CS/LWAKE stays HIGH.

## 1.1.4 TRANSMITTER OFF MODE

In TRANSMITTER OFF mode, the receiver is enabled but the LBUS transmitter is off. It is a lower power mode.

In order to minimize the power consumption, the window watchdog timer is disabled and the regulator operates in a reduced power mode. It has a lower GBW product and thus is slower. However, the 70 mA drive capability is unchanged.

The transmitter may be re-enabled whenever the FAULT/TXE signal returns high, by removing the internal fault condition and the CPU returning the FAULT/TXE high. The transmitter will not be enabled even if the FAULT/TXE pin is brought high externally, when the internal fault is still present. However, externally forcing the FAULT/TXE high, while the internal fault is still present, should be avoided since this will induce high current and power dissipation in the FAULT/TXE pin.

The transmitter is also turned off whenever the voltage regulator is unstable or recovering from a fault. This prevents unwanted disruption of the bus during times of uncertain operation.

## 1.1.5 POWER-DOWN MODE

In POWER-DOWN mode, the transceiver and the voltage regulator are both off. Only the Bus Wake-up section and the CS/LWAKE pin wake-up circuits are in operation. This is the lowest power mode.

If any bus activity (e.g. a BREAK character) occurs during POWER-DOWN mode, the device will immediately enter READY mode and enable the voltage regulator. Then, once the regulator output has stabilized (approximately 0.3 ms to 1.2 ms) it goes to OPERATION mode. Refer to [Section 1.1.6 "Remote Wake-up"](#) for more details.

The part will also enter READY mode from POWER-DOWN mode, followed by OPERATION mode, if the CS/LWAKE pin becomes active HIGH ('1').

## 1.1.6 REMOTE WAKE-UP

The remote wake-up sub module observes the LBUS in order to detect bus activity. In POWER DOWN mode, normal LIN recessive/dominant threshold is disabled, and the LIN bus Wake-Up Voltage Threshold  $V_{WK(LBUS)}$  is used to detect bus activities. Bus activity is detected when the voltage on the LBUS falls below the LIN bus Wake-Up Voltage Threshold  $V_{WK(LBUS)}$  (approximately 3.4V) for at least  $t_{BDB}$  (a typical duration of 80  $\mu$ s) followed by a rising edge. Such a condition causes the device to leave POWER-DOWN mode.

**TABLE 1-1: OVERVIEW OF OPERATIONAL MODES**

State	Transmitter	Receiver	Internal Wake Module	Voltage Regulator	Watch Dog Timer	Operation	Comments
POR	OFF	OFF	OFF	OFF	OFF	Transfer to READY mode after $V_{BB} > V_{ON}$ .	
READY	OFF	ON	OFF	ON	ON	If CS/LWAKE high, then proceed to OPERATION or TRANSMITTER OFF mode.	Bus Off state
OPERATION	ON	ON	OFF	ON	ON	If CS/LWAKE low level, then Power down. If FAULT/TXE low level, then TRANSMITTER-OFF mode.	Normal Operation mode
POWER DOWN	OFF	OFF	ON Activity Detect	OFF	OFF	On LIN bus rising edge or CS/LWAKE high level, go to READY mode.	Lowest Power mode
TRANSMITTER OFF	OFF	ON	OFF	ON	OFF	If CS/LWAKE low level, then Power down. If FAULT/TXE high, then OPERATION mode.	Bus Off state, Lower Power mode

## 1.2 WINDOWED WATCHDOG RESET

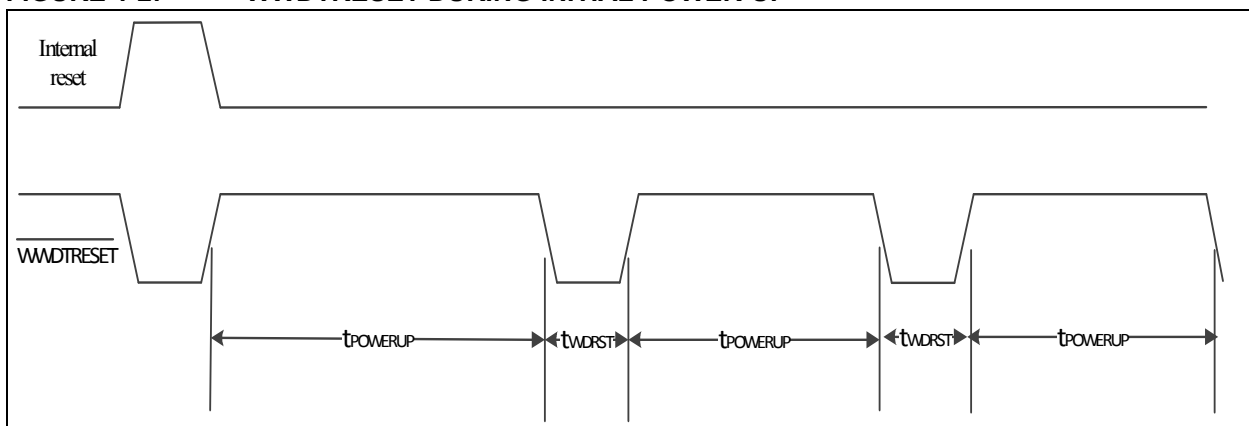
The Watchdog Timer monitors for activity on the Windowed Watchdog Timer Trigger input pin  $\overline{\text{WWDTTTRIG}}$ . The  $\overline{\text{WWDTTTRIG}}$  pin is expected to be strobed within a given time frame. When this time frame has expired, without an edge transition on the  $\overline{\text{WWDTTTRIG}}$  pin, the  $\overline{\text{WWDTTRESET}}$  pin is driven active (LOW) to reset the system. This feature is enabled by connecting a resistor between the  $\overline{\text{WWDTTSELECT}}$  pin and  $V_{\text{SS}}$ . Monitoring is then done by requiring the host processor to force an falling edge transition on the  $\overline{\text{WWDTTTRIG}}$  pin within a predetermined time frame (TWD).

The start time of the trigger window is fixed at 50% of the total watchdog period, after the last trigger. The length of the window is determined by the value of the resistor on pin  $\overline{\text{WWDTTSELECT}}$ . The Watchdog Timer is disabled if  $\overline{\text{WWDTTSELECT}}$  is floating.

### 1.2.1 WWDT During Initial Power-up

The  $\overline{\text{WWDTTRESET}}$  is driven high after a power-on reset. The Watchdog Timer begins counting at this point, awaiting an edge on  $\overline{\text{WWDTTTRIG}}$  pin. Note that there is no window enabled, yet. If no falling edge is detected on the  $\overline{\text{WWDTTTRIG}}$  pin before the timer expires, the  $\overline{\text{WWDTTRESET}}$  is pulse low and the timer is restarted. When a trigger edge on the  $\overline{\text{WWDTTTRIG}}$  pin is seen, the window is enabled and the timer is reset.

**FIGURE 1-2: WWDTTRESET DURING INITIAL POWER-UP**



**FIGURE 1-2: “WWDTTRESET DURING INITIAL POWER-UP”** shows the behavior of the  $\overline{\text{WWDTTRESET}}$  pin after a system reset with no trig at all. If no trig is given during the power-up window,  $\overline{\text{WWDTTRESET}}$  is reset low for the time  $t_{\text{WDRST}}$ .

The power-up window length  $t_{\text{POWERUP}}$  duration is determined by the value of the resistor connected between pin  $\overline{\text{WWDTTSELECT}}$  and pin  $V_{\text{SS}}$ , while the reset pulse duration is about 150 us.

Duration for  $t_{\text{POWERUP}}$  and  $t_{\text{WDRST}}$  are:

$$t_{\text{POWERUP}} = 0.8 \text{ ms} \times (\text{R}_{\overline{\text{WWDTTSELECT}}} + 1) \pm 15\%$$

$$t_{\text{WDRST}} = 150\text{us} \pm 35\%$$

$\text{R}_{\overline{\text{WWDTTSELECT}}}$  is in  $\text{k}\Omega$ .

Once a trig is asserted, the power-up sequence “stops” and the normal behavior begins.

### 1.2.2 WINDOWED WATCHDOG BEHAVIOR

After windowed watchdog begins its normal behavior, three different cases can appear.

- A pulse (falling edge) on the  $\overline{\text{WWDTTTRIG}}$  pin is detected within the trigger window; the watchdog timer will be reset, and a new watchdog period will begin;  $\overline{\text{WWDTTRESET}}$  pin remains high (Figure 1-3.)
- A pulse (falling edge) on the  $\overline{\text{WWDTTTRIG}}$  pin is

detected before the trigger window (too early trigger);  $\overline{\text{WWDTTRESET}}$  is asserted (LOW) immediately after the falling edge is detected for approximately  $t_{\text{WDRST}}$ ; the counter is reset and the next watchdog period begins at the rising edge of the voltage on  $\overline{\text{WWDTTRESET}}$  pin (Figure 1-14).

- No pulse on the  $\overline{\text{WWDTTTRIG}}$  pin is detected during the whole watchdog window (no trigger),  $\overline{\text{WWDTTRESET}}$  is asserted (LOW) for approximately  $t_{\text{WDRST}}$  when the timer has expired; the counter is reset and the next watchdog period begins at the rising edge of the voltage on  $\overline{\text{WWDTTRESET}}$  pin (Figure 1-5).

The trigger window is between 50% to 100% of the watchdog window length. The window length is determined by the external resistor between  $\overline{\text{WWDTTSELECT}}$  pin and  $V_{\text{SS}}$ .

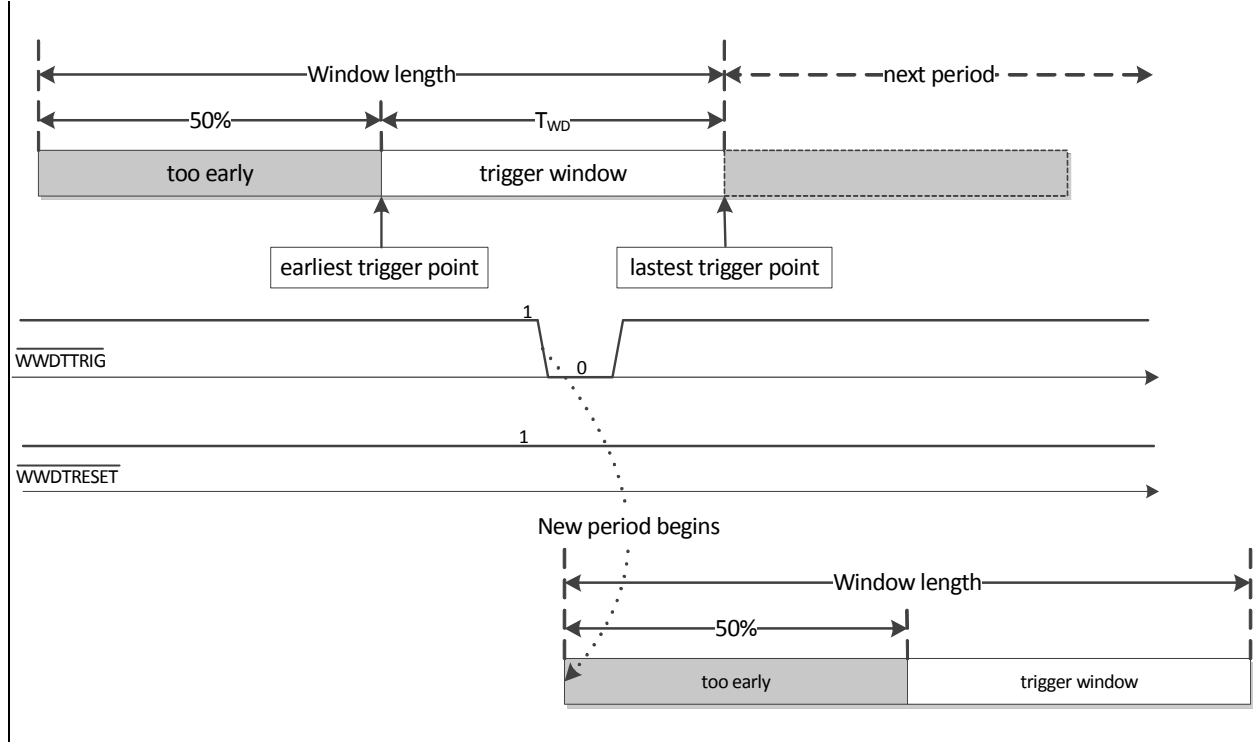
$$\text{WINDOW LENGTH} = 0.2 \text{ ms} \times (\text{R}_{\overline{\text{WWDTTSELECT}}} + 1) \pm 15\%$$

$$t_{\text{WDRST}} = 150\text{uS} \pm 35\%$$

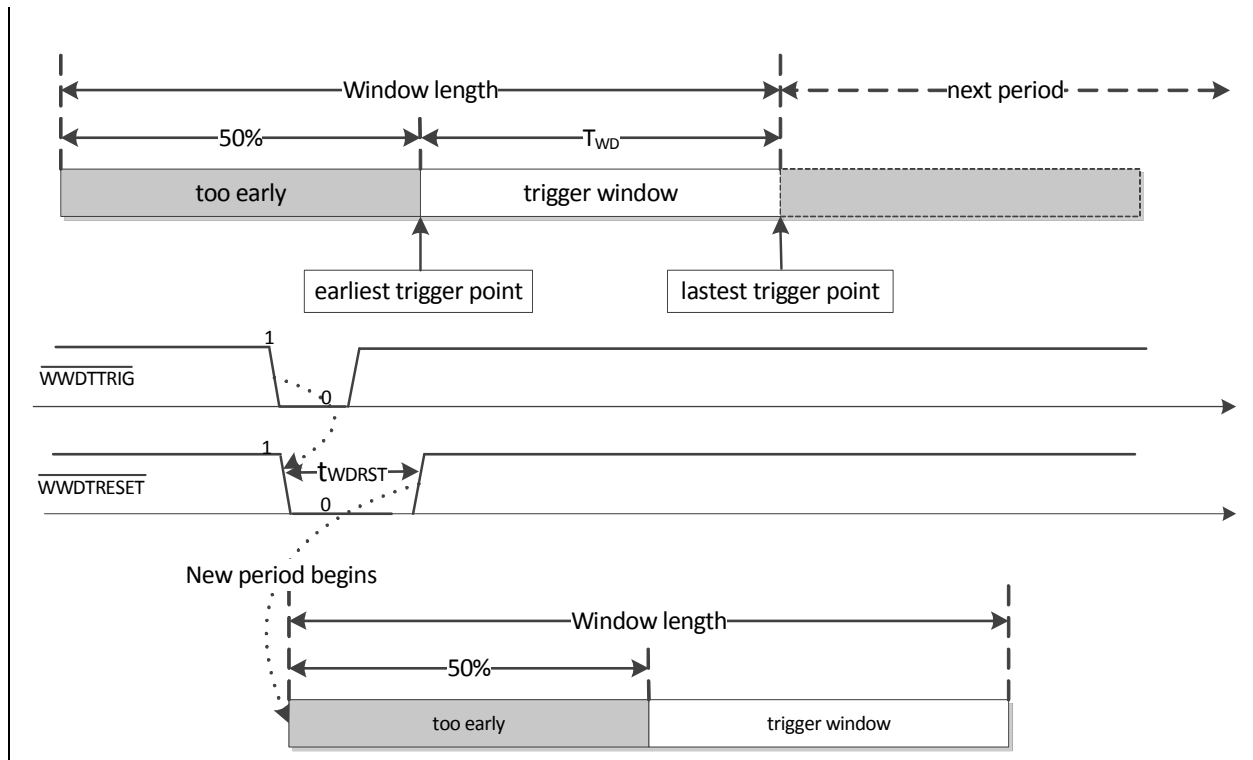
$\text{R}_{\overline{\text{WWDTTSELECT}}}$  is in  $\text{k}\Omega$ ; its value ranges from 33  $\text{k}\Omega$  to 680  $\text{k}\Omega$  and window length ranges from 6.8 ms to 136  $\pm 15\%$ .

If the  $\overline{\text{WWDTTSELECT}}$  pin is floating, the watchdog is disabled and the  $\overline{\text{WWDTTRESET}}$  remains HIGH.

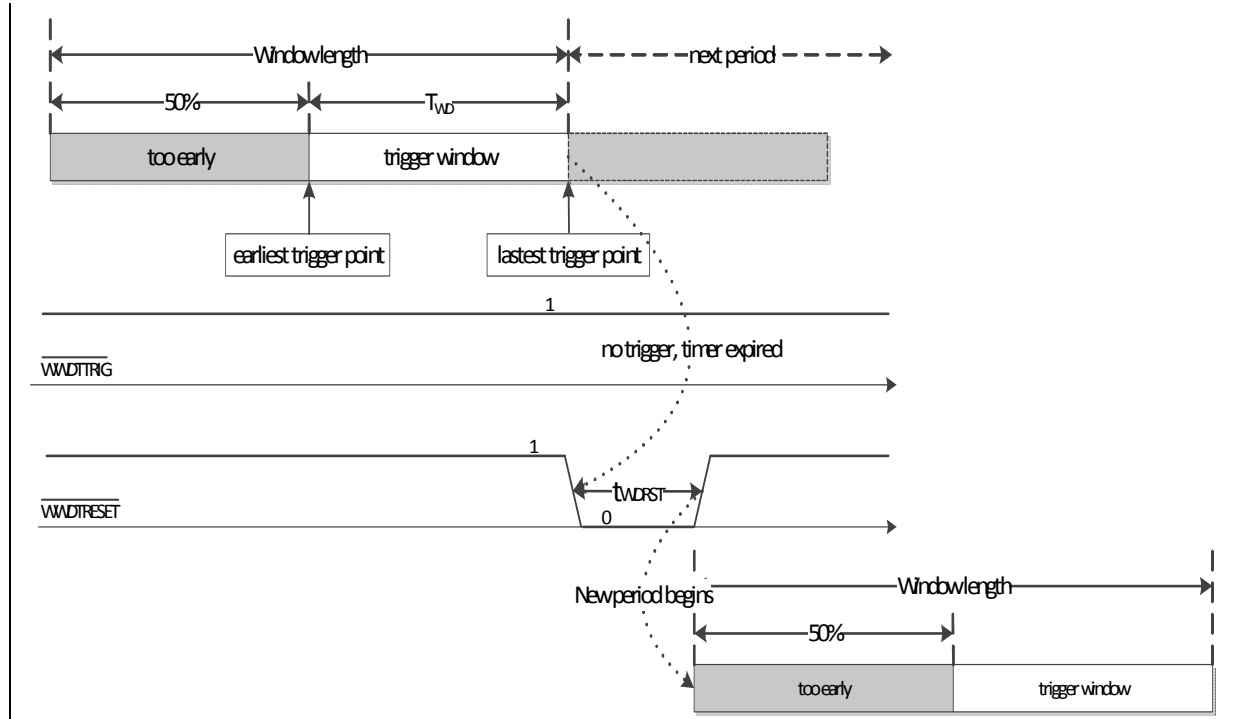
**FIGURE 1-3: CORRECT TRIGGER**



**FIGURE 1-4: TOO EARLY TRIGGER**



**FIGURE 1-5: NO TRIGGER**



## 1.3 Pin Descriptions

Please refer to [Table 1-2](#) for the pinout overview.

### 1.3.1 VBB

Battery Positive Supply Voltage pin. An external diode is connected in series to prevent the device from being reversely powered (refer [Figure 1-14](#)).

### 1.3.2 VREG

Positive Supply Voltage Regulator Output pin. An on-chip LDO gives +5.0 or +3.3V 70 mA regulated voltage on this pin.

### 1.3.3 VSS

Ground pin.

### 1.3.4 TXD

Transmit Data Input pin (TTL level, HV compliant, adaptive pull-up). The transmitter reads the data stream on TXD pin and sends it to LIN bus. The LBUS pin is low (dominant) when TXD is low, and high (recessive) when TXD is high.

The Transmit Data Input pin has an internal adaptive pull-up to an internally-generated 4.2V (approximate). When TXD is '0', a weak pull-up (~900 k $\Omega$ ) is used to reduce current. When TXD is '1' a stronger pull-up (~300 k $\Omega$ ) is used to maintain the logic level. A series reverse-blocking diode allows applying TXD input volt-

ages greater than the internally generated 4.2V and renders TXD pin HV compliant up to 30V (see the Block Diagram on page 2).

### 1.3.5 RXD

Receive Data Output pin. The RXD pin is a standard CMOS output pin and it follows the state of the LBUS pin.

### 1.3.6 LBUS

LIN Bus pin. LBUS is a bidirectional LIN bus Interface pin and is controlled by the signal TXD. It has an open collector output with a current limitation. To reduce electromagnetic emission, the slopes during signal changes are controlled, and the LBUS pin has corner-rounding control for both falling and rising edges.

The internal LIN receiver observes the activities on LIN bus, and generates the output signal RXD that follows the state of the LBUS. A first degree 160 kHz, low-pass input filter optimizes electromagnetic immunity.

### 1.3.7 CS/LWAKE

Chip Select and Local Wake-up Input pin (TTL level, high voltage tolerant). This pin controls the device state transition. Refer to [FIGURE 1-1: "State Diagram"](#).

If CS/LWAKE = 1, the device can work in OPERATION mode (FAULT/TXE = 1) or TRANSMITTER OFF mode (FAULT/TXE = 0).

If CS/LWAKE = 0, the device can work in POWER-DOWN mode or READY mode.

An internal pull-down resistor will keep the CS/LWAKE pin low to ensure that no disruptive data will be present on the bus while the microcontroller is executing a Power-on Reset and I/O initialization sequence. When CS/LWAKE is '1', a weak pull-down (~600 kΩ) is used to reduce current. When CS/LWAKE is '0' a stronger pull-down (~300 kΩ) is used to maintain the logic level.

This pin may also be used as a local wake-up input (see [Figure 1-14](#)). The microcontroller will set the I/O pin to control the CS/LWAKE. An external switch, or other source, can then wake-up both the transceiver and the microcontroller.

<p><b>Note:</b> CS/LWAKE should NOT be tied directly to pin VREG as this could force the MCP2050 into Operation Mode before the microcontroller is initialized.</p>
---

### 1.3.8 $\overline{\text{FAULT/TXE}}$

Fault Detect Output/Transmitter Enable Input pin. The output section is HV tolerant open drain (up to 30V). The input section is identical with TXD section (TTL level, HV compliant, adaptive pull-up). Internal adaptive pull-up maintains this input high '1' if the pin is floating. Its state is defined as shown in [Table 1-3](#). The device is placed in TRANSMITTER OFF mode whenever this pin is LOW ('0'), either from an internal fault condition or by external drive.

If CS/LWAKE is HIGH ('1'), the  $\overline{\text{FAULT/TXE}}$  signals a mismatch between the TXD input and the L<sub>BUS</sub> level. This can be used to detect a bus contention. Since the bus exhibits a propagation delay, the sampling of the internal compare is debounced to eliminate false faults.

After the device wakes up, the  $\overline{\text{FAULT/TXE}}$  indicates what wakes the device if CS/LWAKE remains LOW ('0') (refer to [Table 1-3](#)).

The  $\overline{\text{FAULT/TXE}}$  pin sampled at a rate faster than every 10 μs.

### 1.3.9 $\overline{\text{RESET}}$

RESET OUTPUT pin. This pin is open drain with ~90 kΩ pull-up to VREG. It indicates the internal voltage has reached a valid, stable level. As long as the internal voltage is valid (above 0.8V<sub>REG</sub>), this pin will remain HIGH ('1'); otherwise the RESET pin switches to LOW ('0').

### 1.3.10 $\overline{\text{WWDTRRESET}}$

$\overline{\text{WWDTRRESET}}$  is an open-drain output pin. This pin is asserted low when the internal Windowed Watchdog Timer has expired or an attempt was made to clear the timer before the window has opened.

### 1.3.11 $\overline{\text{WWDTRTRIG}}$

This is an input pin to reset the Windowed Watchdog Timer. A high-to-low transition during the open window time will reset the timer and prevent the WWD<sub>T</sub> from timing out. The pin has an internal adaptive pull-up to an internally-generated 4.2V (approximate).

When  $\overline{\text{WWDTRTRIG}}$  is '0', a weak pull-up (~800 kΩ) is connected to reduce current.

When  $\overline{\text{WWDTRTRIG}}$  is '1' the pull-up is stronger to maintain the logic level.



**TABLE 1-2: PINOUT OVERVIEW**

PIN Name	PIN Number		PIN Type	Function
	14 PIN	20 PIN		
VREG	4	3	Output	Voltage Regulator Output
VSS	8	8	Power	Ground
VBB	10	12	Power	Battery
TXD	5	4	Input, HV-tolerant	Transmit Data Input
RXD	2	1	Output	Receive Data Output
LBUS	9	7	I/O, HV	LIN Bus
CS/LWAKE	3	2	TTL Input, HV-tolerant	Chip Select and Local Wake-up Input
$\overline{\text{FAULT/TXE}}$	11	13	I/O, HV-tolerant	Fault Detect Output/Transmitter Enable Input
$\overline{\text{RESET}}$	6	5	Output	Reset Output
$\overline{\text{WWDTRSET}}$	14	17	Output, HV-tolerant	Windowed Watchdog Reset Output
$\overline{\text{WWDTRIG}}$	13	15	Input	Windowed Watchdog Trigger Input
WWDTSELECT	12	14	Input	A Resistor between this Pin and Ground determines the Watchdog Window length
VBATRATIO	1	18	Analog Output	$\text{VBATRATIO} = \text{VBAT}/24 * \text{VREG}$
NC	7	6,9,10,11, 16,19,20	Not Connected	

**TABLE 1-3:  $\overline{\text{FAULT/TXE}}$  TRUTH TABLE**

TXD In	RXD Out	LIN BUS I/O	Thermal Override	$\overline{\text{FAULT/TXE}}$		Definition
				External Input	Driven Output	
CS = 1						
L	H	VBB	OFF	H	L	<b>FAULT</b> , TXD driven low, LIN BUS shorted to VBB ( <b>Note 1</b> ), or L <sub>BUS</sub> /TXD permanent dominant detected, and Transmit time-out shutdown.
H	H	VBB	OFF	H	H	<b>OK</b>
L	L	GND	OFF	H	H	<b>OK</b>
H	L	GND	OFF	H	H	<b>OK</b> , data is being received from the LIN BUS
x	x	VBB	ON	H	L	<b>FAULT</b> , Transceiver in thermal shutdown
x	x	VBB	x	L	x	<b>NO FAULT</b> , the CPU is commanding the transceiver to turn off the transmitter driver
CS = 0 after a wake-up						
x	x	x	x	x	L	<b>Wake-up from LIN bus activity</b>
x	x	x	x	x	H	<b>Wake-up from POR</b>

**Legend:** x = don't care

**Note 1:** The  $\overline{\text{FAULT/TXE}}$  is valid after approximately 25  $\mu\text{s}$  after TXD falling edge. This is to eliminate false fault reporting during bus propagation delays.

## 1.3.12 WWDTSELECT

This is an analog input pin that sets the open window time to accept a trigger reset. A resistor between this pin and VSS set this time. A value between 33 kΩ and 680 kΩ is determined by the following equation:

The normal window length:

$$t_{\text{NORMAL}} = 0.2 \text{ ms} * (\text{RWWDTSELECT} + 1) \pm 15\%$$

The power up window length:

$$t_{\text{POWERUP}} = 0.8 \text{ ms} * (\text{RWWDTSELECT} + 1) \pm 15\%$$

The RESET signal duration:

$$t_{\text{WDRST}} = 150 \text{ uS} \pm 35\%$$

RWWDTSELECT is in kΩ.

The normal window length ranges from 6.8 ms [0.2 \* (33+1), typical] to 136 ms [0.2 \* (680+1)]. Similarly, the power up window length ranges from 27 ms to 545 ms, typical, and the RESET signal duration is 150uS.

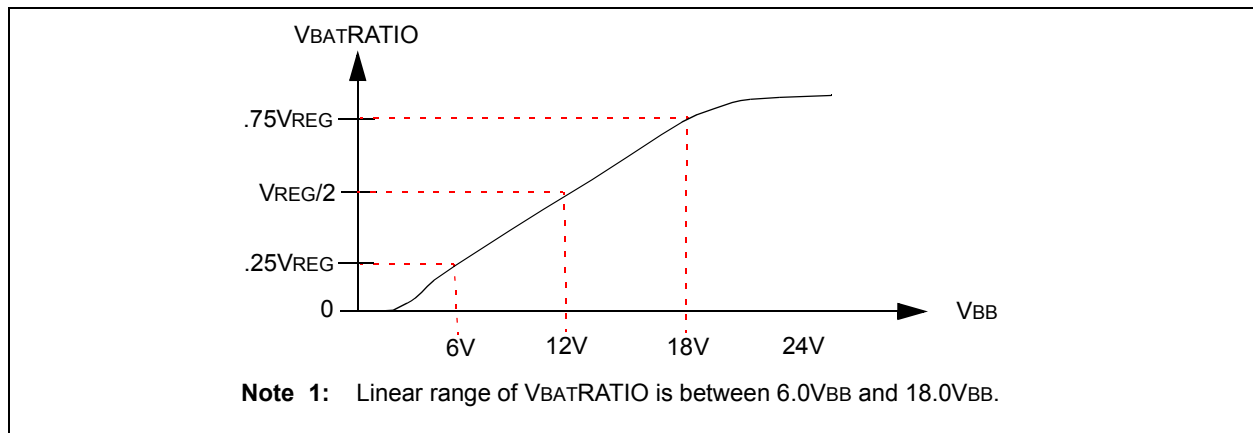
## 1.3.13 VBATRATIO

This is an analog output pin that reflects the voltage at the VBAT pin. It is scaled by VREG such that:

$$\text{VBATRATIO} = \text{VBAT}/24 * \text{VREG}$$

$$0 \leq \text{VBATRATIO} \leq \text{VREG}$$

**FIGURE 1-6: VBATRATIO OUTPUT RANGE**



## 1.4 Fail-Safe Features

### 1.4.1 GENERAL FAIL-SAFE FEATURES

- An internal pull-down resistor on the CS/LWAKE pin disables the transmitter if the pin is floating.
- An internal pull-up resistor on the TXD pin places TXD in HIGH, thus the LBUS is recessive if the TXD pin is floating.
- High-impedance and low leakage current on LBUS during loss of power or ground.
- The current limit on LBUS protects the transceiver from being damaged if the pin is shorted to VBB.

### 1.4.2 THERMAL PROTECTION

The thermal protection circuit monitors the die temperature and is able to shut down the LIN transmitter and voltage regulator.

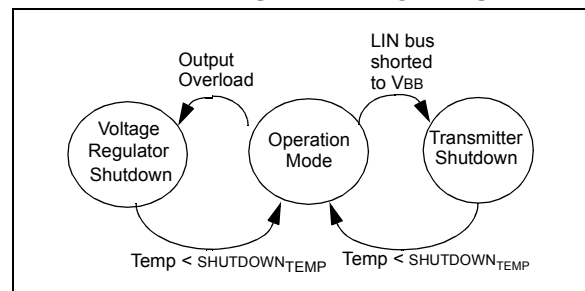
There are three causes for a thermal overload. A thermal shut down can be triggered by any one, or a combination of, the following thermal overload conditions.

- Voltage regulator overload
- LIN bus output overload
- Increase in die temperature due to increase in environment temperature

The recovery time from the thermal shutdown is equal to adequate cooling time.

Driving the TXD and checking the RXD pin makes it possible to determine whether there is a bus contention (TXD = high, RXD = low) or a thermal overload condition (TXD = low, RXD = high).

**FIGURE 1-7: THERMAL SHUTDOWN STATE DIAGRAMS**



### 1.4.3 TXD/LBUS TIME-OUT TIMER

LIN bus can be driven to a dominant level either from TXD pin or externally. An internal timer deactivates the LBUS transmitter if a dominant status (LOW) on LIN bus lasts longer than Bus Dominant Time-out Time  $t_{TO(LIN)}$  (approximately 20 ms); at the same time, RXD output is put in recessive (HIGH),  $\overline{FAULT/TXE}$  is also driven to LOW and the internal LIN pull-up resistor is disconnected. The timer is reset on any recessive LBUS status or POR mode. The recessive status on LBUS can be caused either by the bus being externally pulled up or by TXD pin being returned high.

### 1.5 Internal Voltage Regulator

The MCP2050 has a positive regulator capable of supplying +5.00 or +3.30 Vdc  $\pm 3\%$  at up to 70 mA of load current over the entire operating temperature range of  $-40^{\circ}\text{C}$  to  $+125^{\circ}\text{C}$ . The regulator uses an LDO design, is short-circuit-protected and will turn the regulator output off if its output falls below the Shutdown Voltage Threshold  $V_{SD}$ .

With a load current of 70 mA, the minimum input to output voltage differential required for the output to remain in regulation is typically +0.5V (+1V maximum over the full operating temperature range). Quiescent current is less than 100  $\mu\text{A}$  with a full 70 mA load current when the input to output voltage differential is greater than +3.00V.

Regarding the correlation between  $V_{BB}$ ,  $V_{REG}$  and  $I_{DD}$ , refer to [Figure 1-11](#) and [Figure 1-12](#). When the input voltage ( $V_{BB}$ ) drops below the differential needed to provide stable regulation, the voltage regulator output  $V_{REG}$  will track the input down to approximately  $V_{OFF}$ . The regulator will turn off the output at this point. This will allow PIC<sup>®</sup> microcontrollers, with internal POR circuits, to generate a clean arming of the Power-on Reset trip point. The MCP2050 will then monitor  $V_{BB}$  and turn on the regulator when  $V_{BB}$  is above the threshold of regulator turn on voltage  $V_{ON}$ .

Under specific ambient temperature and battery voltage range, the voltage regulator can output as high as 150 mA current.

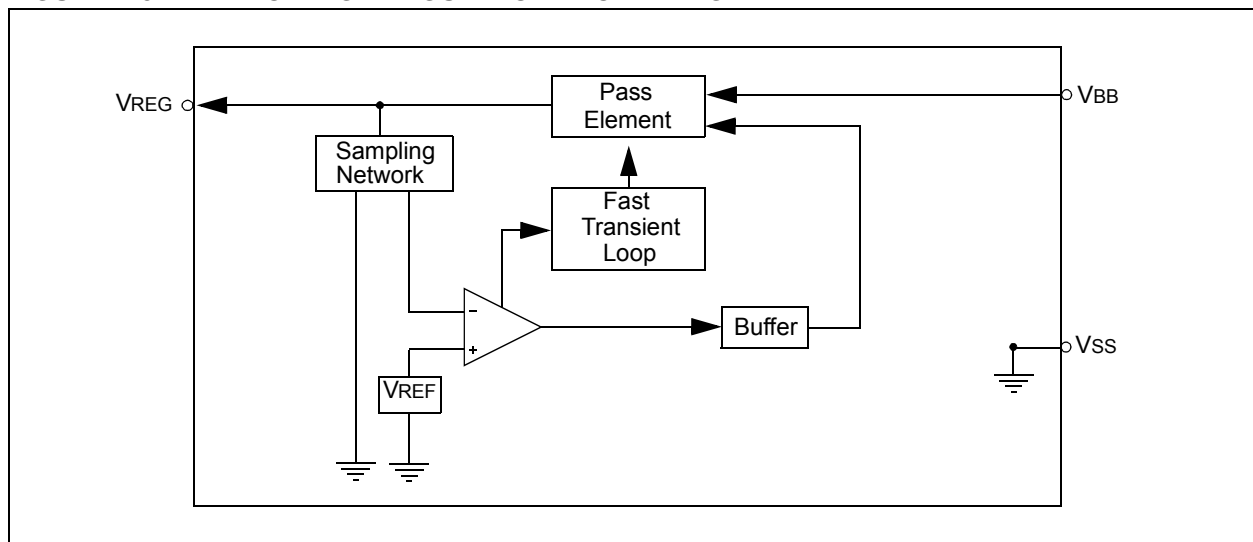
For current load capability of the voltage regulator, refer to [Figure 1-11](#) and [Figure 1-11](#).

In Power-down mode, the  $V_{BB}$  monitor is turned off.

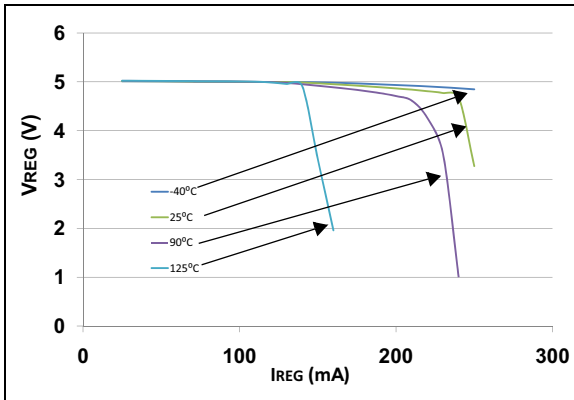
**Note:** The regulator overload current limit is approximately 250 mA. The regulator output voltage  $V_{REG}$  is monitored. If output voltage  $V_{REG}$  is lower than  $V_{SD}$ , the voltage regulator will turn off. After a recovery time of about 3 ms, the  $V_{REG}$  will be checked again. If there is no short circuit, ( $V_{REG} > V_{SD}$ ) then the voltage regulator remains on.

The regulator requires an external output bypass capacitor for stability. See [FIGURE 2-1: "ESR Curves For Load Capacitor Selection"](#) for correct capacity and ESR for stable operation.

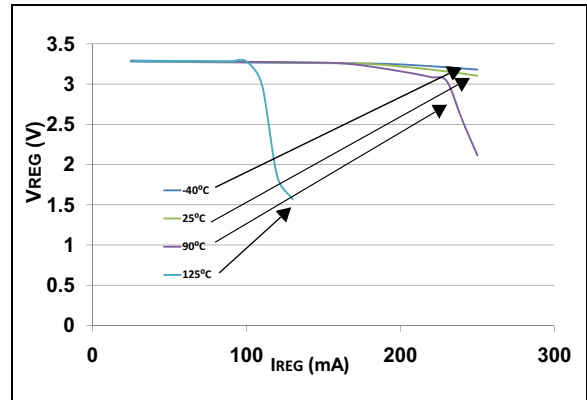
**FIGURE 1-8: VOLTAGE REGULATOR BLOCK DIAGRAM**



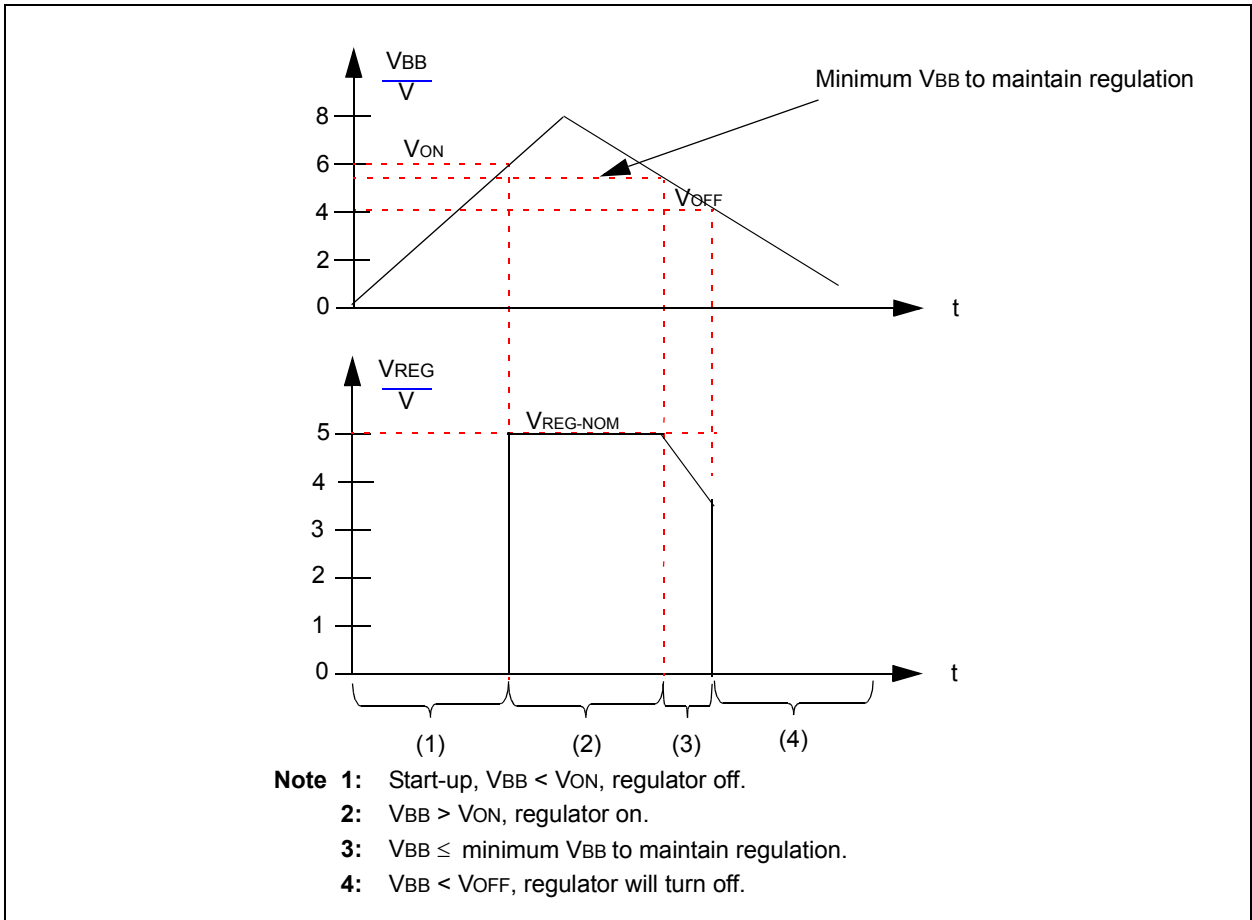
**FIGURE 1-9: 5.0V  $V_{REG}$  VS.  $I_{REG}$  AT  $V_{BB} = 12V$**



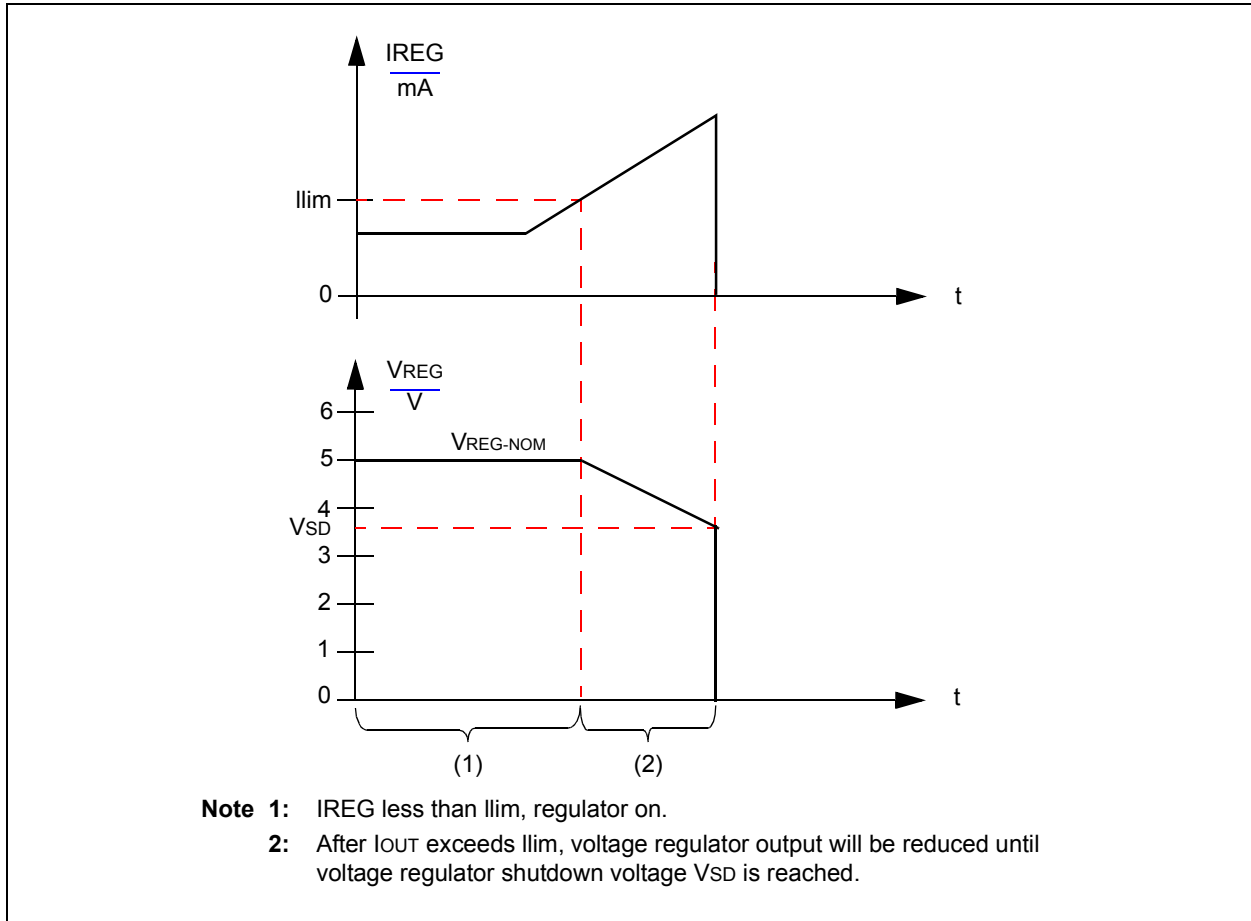
**FIGURE 1-10: 3.3V  $V_{REG}$  VS.  $I_{REG}$  AT  $V_{BB} = 12V$**



**FIGURE 1-11: VOLTAGE REGULATOR OUTPUT ON POWER-ON RESET**



**FIGURE 1-12: VOLTAGE REGULATOR OUTPUT ON OVER CURRENT SITUATION**



## 1.6 Optional External Protection

### 1.6.1 REVERSE BATTERY PROTECTION

An external reverse-battery-blocking diode should be used to provide polarity protection (see [Figure 1-14](#)).

### 1.6.2 TRANSIENT VOLTAGE PROTECTION (LOAD DUMP)

An external 43V transient suppressor (TVS) diode, between VBB and ground, with a transient protection resistor (RTP) in series with the battery supply and the VBB pin protects the device from power transients and ESD events greater than 43V (see [Figure 1-14](#)). The maximum value for the RTP protection resistor depends on two parameters: the minimum voltage the part will start at, and the impacts of this RTP resistor on the VBB value, thus on the Bus recessive level and slopes.

This leads to a set of three equations to fulfill.

[Equation 1-1](#) provides a max RTP value according to the minimum battery voltage the user wants the part to start at.

[Equation 1-2](#) provides a max RTP value according to the maximum error on the recessive level thus VBB since the part uses VBB as the reference value for the recessive level.

[Equation 1-3](#) provides a max RTP value according to the maximum relative variation the user can accept on the slope when IREG varies.

Since both [Equation 1-1](#) and [Equation 1-2](#) must be fulfilled, the maximum allowed value for RTP is thus the smaller of the two values found when solving [Equation 1-1](#) and [Equation 1-2](#).

Usually [Equation 1-1](#) gives the higher constraint (smaller value) for RTP as shown in the following example where VBATmin is 8V.

However, the user needs to check that the value found with [Equation 1-1](#) also fulfills [Equation 1-2](#) and [Equation 1-3](#).

While this protection is optional, it should be considered as good engineering practice.

## EQUATION 1-1:

$$R_{TP} \leq \frac{V_{BATmin} - 5.5V}{250mA}$$

$$5.5V = V_{OFF} + 1.0V$$

*250 mA is the peak current at power-on when V<sub>BB</sub> = 5.5V*

Assume V<sub>BATMIN</sub> = 8V. Equation 1-1 shows 10Ω.

## EQUATION 1-2:

$$R_{TP} \leq \Delta V_{RECESSIVE} / I_{REGMAX}$$

*ΔV<sub>RECESSIVE</sub> is the maximum variation tolerated on the recessive level*

Assume ΔV<sub>RECESSIVE</sub> = 1V and I<sub>REGMAX</sub> = 50 mA. Equation 1-2 shows 20Ω.

## EQUATION 1-3:

$$R_{TP} \leq \frac{\Delta Slope \times (V_{BATmin} - 1V)}{I_{regmax}}$$

*ΔSlope is the maximum variation tolerated on the slope level and I<sub>REGMAX</sub> is the maximum current the regulator will provide to the load. V<sub>BATMIN</sub> > V<sub>OFF</sub> + 1.0V*

Assume ΔSlope=15%, V<sub>BATMIN</sub>=8V and I<sub>REGMAX</sub>=50 mA. Equation 1-2 shows 20Ω.

### 1.6.3 C<sub>BAT</sub> CAP

Selecting C<sub>BAT</sub> = 10\* C<sub>REG</sub> is recommended, however this leads to a high value cap. Lower values for C<sub>BAT</sub> cap can be used with respect to some rules. In any case, the voltage at the V<sub>BB</sub> pin should remain above V<sub>OFF</sub> when the device is turned on.

The current peak at start-up (due to the fast charge of the C<sub>REG</sub> and C<sub>BAT</sub> capacitor) may induce a significant drop on the V<sub>BB</sub> pin. This drop is proportional to the impedance of the V<sub>BAT</sub> connection (see Figure 1-14).

Assume that the V<sub>BAT</sub> connection is mainly inductive and resistive and that the customer knows the resistive and inductive values of the connection.

The following formula gives an indication of the minimum value the customer should use for C<sub>BAT</sub>:

## EQUATION 1-4:

$$\frac{C_{BAT}}{C_{REG}} = \sqrt{\frac{100L^2 + R_{tot}^2}{1 + L^2 + \frac{R_{tot}^2}{100}}}$$

where L is in mH and R<sub>tot</sub> in Ω.  
R<sub>TOT</sub> = R<sub>LINE</sub> + R<sub>TP</sub>.

Equation 1-4 allows lower C<sub>BAT</sub>/C<sub>REG</sub> values than the 10\* ratio we recommend.

Let's assume that we have a good quality connection with R<sub>TOT</sub> = 0.1Ω and L = 0.1 mH.

Solving the equation, the result is C<sub>BAT</sub>/C<sub>REG</sub> = 1.

If we increase R<sub>TOT</sub> up to 1Ω, the result becomes C<sub>BAT</sub>/C<sub>REG</sub> = 1.4.

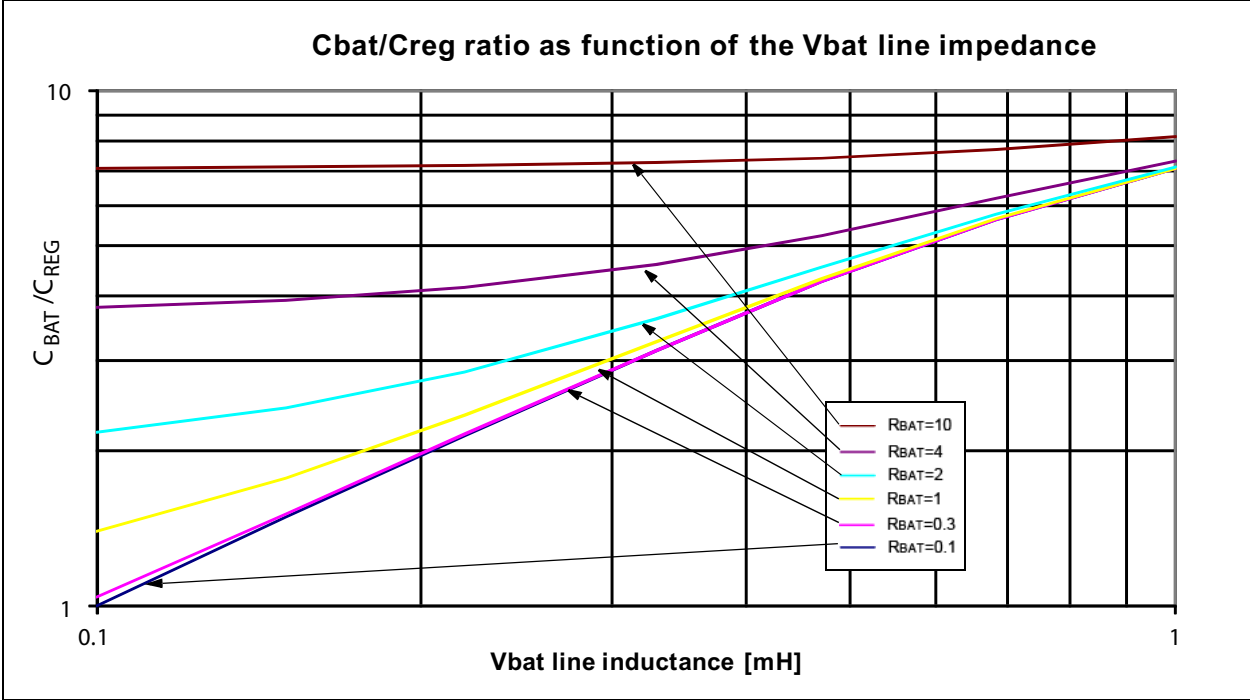
But if the connection is highly resistive or highly inductive (poor connection), the C<sub>BAT</sub>/C<sub>REG</sub> ratio greatly increases.

For a highly inductive connection: R<sub>TOT</sub> = 0.1Ω and L=1 mH: the C<sub>BAT</sub>/C<sub>REG</sub> ratio increases to 7!

For a highly resistive connection: R<sub>TOT</sub> = 10Ω and L=0.1 mH: again the C<sub>BAT</sub>/C<sub>REG</sub> ratio increases to 7!

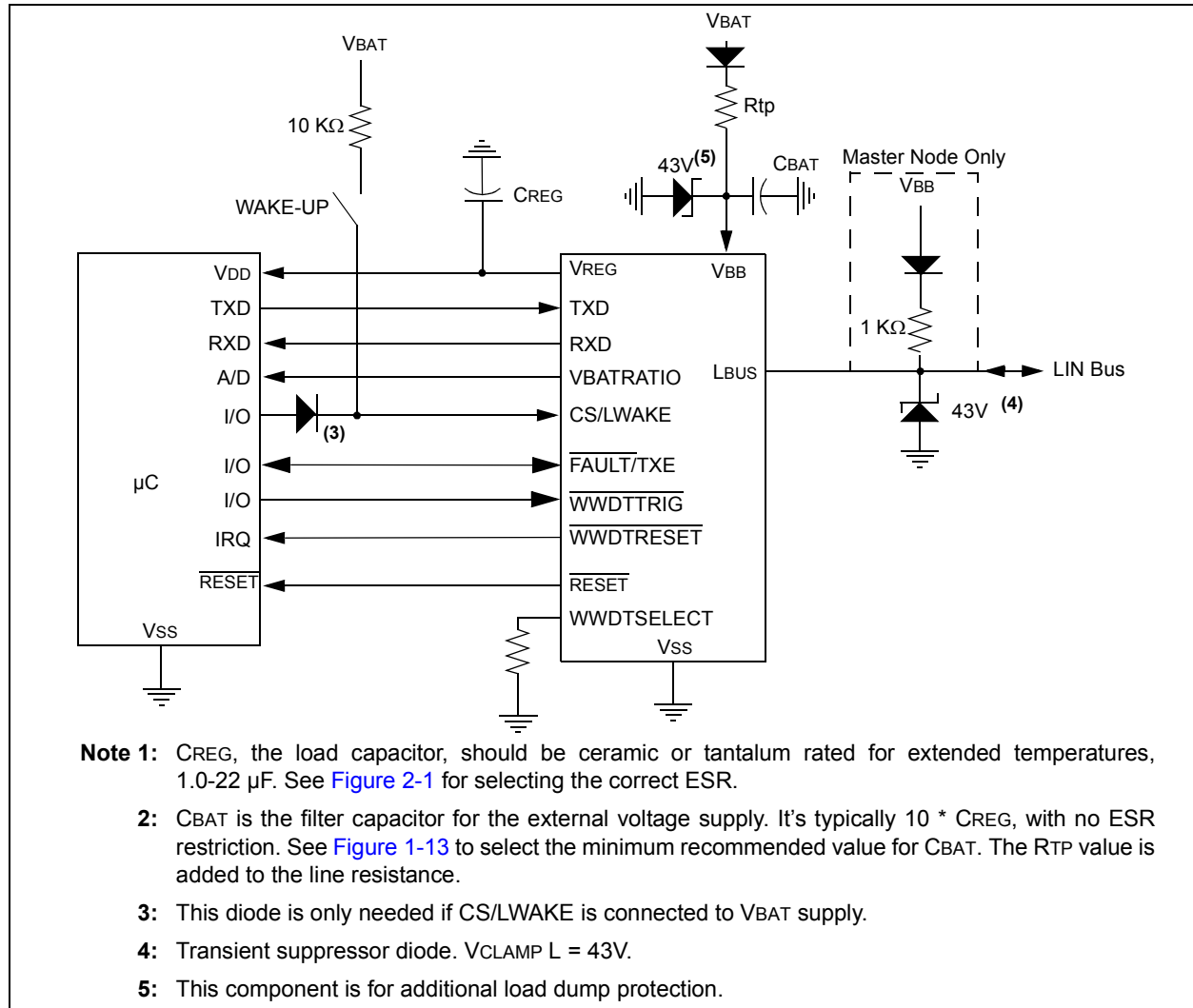
Figure 1-13 shows the minimum recommended C<sub>BAT</sub>/C<sub>REG</sub> ratio as a function of the impedance of the V<sub>BAT</sub> connection.

FIGURE 1-13: Minimum Recommended  $C_{BAT}/C_{REG}$  Ratio

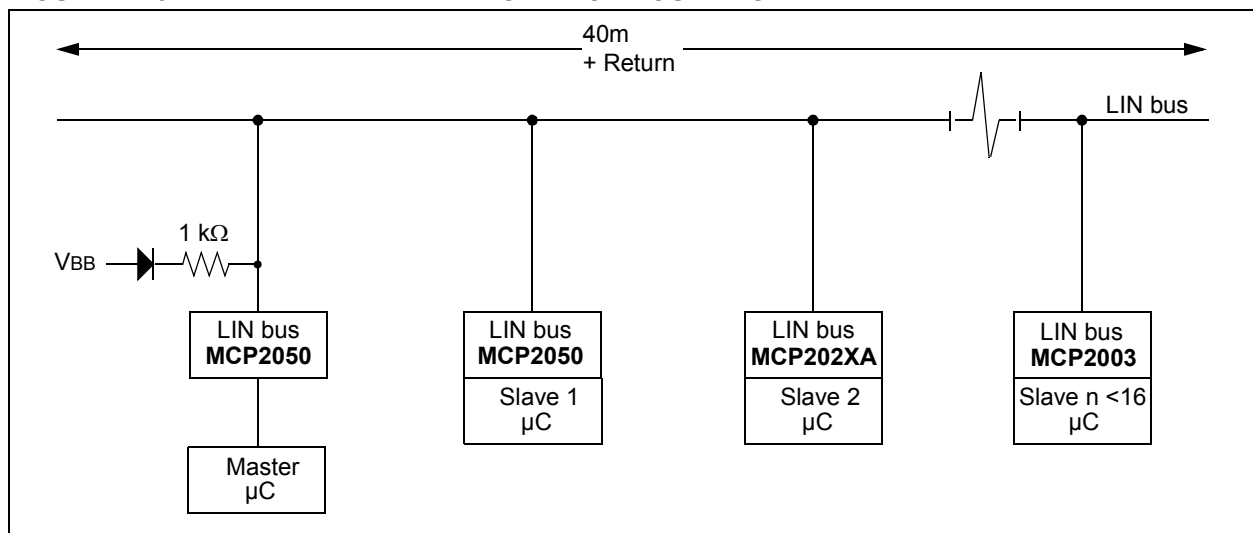


## 1.7 Typical Applications

**FIGURE 1-14: TYPICAL APPLICATION CIRCUIT**



**FIGURE 1-15: TYPICAL LIN NETWORK CONFIGURATION**





## 1.8 ICSP™ Considerations

The following should be considered when the MCP2050 is connected to pins supporting in-circuit programming:

- Power used for programming the microcontroller can be supplied from the programmer, or from the MCP2050.
- The voltage on the pin VREG should not exceed the maximum value of  $V_{REG}$  as shown in [Section 2.3 “DC Specifications”](#).

NOTES:

## 2.0 ELECTRICAL CHARACTERISTICS

### 2.1 Absolute Maximum Ratings†

V <sub>IN</sub> DC Voltage on RXD, and $\overline{\text{RESET}}$ .....	-0.3V to V <sub>REG</sub> +0.3
V <sub>IN</sub> DC Voltage on TXD, CS/LWAKE, $\overline{\text{FAULT}}$ /TXE .....	-0.3 to +40V
V <sub>BB</sub> Battery Voltage, continuous, non-operating (Note 1).....	-0.3 to +40V
V <sub>BB</sub> Battery Voltage, non-operating (LIN bus recessive, no regulator load, t < 60s) (Note 2) .....	-0.3 to +43V
V <sub>BB</sub> Battery Voltage, transient ISO 7637 Test 1 .....	-100V
V <sub>BB</sub> Battery Voltage, transient ISO 7637 Test 2a .....	+75V
V <sub>BB</sub> Battery Voltage, transient ISO 7637 Test 3a .....	-150V
V <sub>BB</sub> Battery Voltage, transient ISO 7637 Test 3b .....	+100V
V <sub>LBUS</sub> Bus Voltage, continuous.....	-18 to +30V
V <sub>LBUS</sub> Bus Voltage, transient (Note 3).....	-27 to +43V
I <sub>LBUS</sub> Bus Short Circuit Current Limit .....	200 mA
ESD protection on LIN, V <sub>BB</sub> (IEC 61000-4-2) (Note 4).....	±15 KV
ESD protection on LIN, V <sub>BB</sub> (Human Body Model) (Note 5).....	±8 KV
ESD protection on all other pins (Human Body Model) (Note 5) .....	±4 KV
ESD protection on all pins (Charge Device Model) (Note 6) .....	±1500V
ESD protection on all pins (Machine Model) (Note 7).....	±200V
Maximum Junction Temperature .....	150°C
Storage Temperature .....	-65 to +150°C

**Note 1:** LIN 2.x compliant specification.

**2:** SAE J2602-2 compliant specification.

**3:** ISO 7637/1 load dump compliant (t < 500 ms).

**4:** According to IEC 61000-4-2, 330 ohm, 150 pF and Transceiver EMC Test Specifications [2] to [4]

**5:** According to AEC-Q100-002 / JESD22-A114

**6:** According to AEC-Q100-011B

**7:** According to AEC-Q100-003 / JESD22-A115

† **NOTICE:** Stresses above those listed under “Maximum Ratings” may cause permanent damage to the device. This is a stress rating only and functional operation of the device at those or any other conditions above those indicated in the operational listings of this specification is not implied. Exposure to maximum rating conditions for extended periods may affect device reliability.

### 2.2 Nomenclature used in this document

Some terms and names used in this data sheet deviate from those referred to in the LIN specifications. Equivalent values are shown below.

LIN 2.1 Name	Term used in the following tables	
V <sub>BAT</sub>	<i>not used</i>	ECU operating voltage
V <sub>SUP</sub>	V <sub>BB</sub>	Supply voltage at device pin
V <sub>BUS_LIM</sub>	ISC	Current Limit of Driver
V <sub>BUSREC</sub>	V <sub>IH</sub> (L <sub>BUS</sub> )	Recessive state
V <sub>BUSDOM</sub>	V <sub>IL</sub> (L <sub>BUS</sub> )	Dominant state

# MCP2050

## 2.3 DC Specifications

DC Specifications	Electrical Characteristics:					
	Unless otherwise indicated, all limits are specified for: V <sub>BB</sub> = 6.0V to 18.0V T <sub>A</sub> = -40°C to +125°C					
Parameter	Sym.	Min.	Typ.	Max.	Units	Conditions
<b>Power</b>						
V <sub>BB</sub> Quiescent Operating Current	IBBQ	—	—	200	μA	I <sub>OUT</sub> = 0 mA, L <sub>BUS</sub> recessive, V <sub>REG</sub> = 5.0V
		—	—	200	μA	I <sub>OUT</sub> = 0 mA, L <sub>BUS</sub> recessive, V <sub>REG</sub> = 3.3V
V <sub>BB</sub> Quiescent Operating Current with Watchdog Enabled	IBBQWDT	—	—	250	μA	I <sub>OUT</sub> = 0 mA, L <sub>BUS</sub> recessive, V <sub>REG</sub> = 5.0V
		—	—	250	μA	I <sub>OUT</sub> = 0 mA, L <sub>BUS</sub> recessive, V <sub>REG</sub> = 3.3V
V <sub>BB</sub> READY Current	IBBRD	—	—	100	μA	I <sub>OUT</sub> = 0 mA, L <sub>BUS</sub> recessive, V <sub>REG</sub> = 5.0V
		—	—	100	μA	I <sub>OUT</sub> = 0 mA, L <sub>BUS</sub> recessive, V <sub>REG</sub> = 3.3V
V <sub>BB</sub> TRANSMITTER-OFF Current with Watchdog Enabled	IBBRDWDT	—	—	130	μA	With voltage regulator on, transmitter off, receiver on, FAULT/TXE = V <sub>IL</sub> , CS = V <sub>IH</sub> , V <sub>REG</sub> = 5.0V
		—	—	130	μA	With voltage regulator on, transmitter off, receiver on, FAULT/TXE = V <sub>IL</sub> , CS = V <sub>IH</sub> , V <sub>REG</sub> = 3.3V
V <sub>BB</sub> TRANSMITTER-OFF Current with Watchdog Disabled	IBBTO	—	—	100	μA	With voltage regulator on, transmitter off, receiver on, FAULT/TXE = V <sub>IL</sub> , CS = V <sub>IH</sub> , V <sub>REG</sub> = 5.0V
		—	—	100	μA	With voltage regulator on, transmitter off, receiver on, FAULT/TXE = V <sub>IL</sub> , CS = V <sub>IH</sub> , V <sub>REG</sub> = 3.3V
V <sub>BB</sub> Power-down Current	IBBPD	—	4.5	8	μA	With voltage regulator powered-off, receiver on and transmitter off, FAULT/TXE = V <sub>IH</sub> , TXD = V <sub>IH</sub> , CS = V <sub>IL</sub> )
V <sub>BB</sub> Current with V <sub>SS</sub> Floating	IBBNOGND	-1	—	1	mA	V <sub>BB</sub> = 12V, GND to V <sub>BB</sub> , V <sub>LIN</sub> = 0-18V
<b>Microcontroller Interface</b>						
High Level Input Voltage (TXD, FAULT/TXE, WWDTRIG)	V <sub>IH</sub>	2.0	—	V <sub>REG</sub> +0.3	V	

## 2.3 DC Specifications (Continued)

DC Specifications	Electrical Characteristics: Unless otherwise indicated, all limits are specified for: $V_{BB} = 6.0V$ to $18.0V$ $T_A = -40^{\circ}C$ to $+125^{\circ}C$						
	Parameter	Sym.	Min.	Typ.	Max.	Units	Conditions
Low Level Input Voltage (TXD, FAULT/TXE, WWDTTTRIG)	V <sub>IL</sub>	-0.3	—	—	0.8	V	
High Level Input Current (TXD, FAULT/TXE, WWDTTTRIG)	I <sub>IH</sub>	-2.5	—	—	0.4	μA	Input voltage = 4.0V. ~800 kΩ internal adaptive pull-up
Low Level Input Current (TXD, FAULT/TXE, WWDTTTRIG)	I <sub>IL</sub>	-10	—	—	—	μA	Input voltage = 0.5V. ~800 kΩ internal adaptive pull-up
High Level Input Voltage (CS/LWAKE)	V <sub>IH</sub>	2.0	—	—	V <sub>BB</sub>	V	Through a current-limiting resistor
Low Level Input Voltage (CS/LWAKE)	V <sub>IL</sub>	-0.3	—	—	0.8	V	
High Level Input Current (CS/LWAKE)	I <sub>IH</sub>	—	—	—	8.0	μA	Input voltage = 0.8V <sub>REG</sub> ~1.3 MΩ internal pull- down to V <sub>SS</sub>
Low Level Input Current (CS/LWAKE)	I <sub>IL</sub>	—	—	—	5.0	μA	Input voltage = 0.2V <sub>REG</sub> ~1.3 MΩ internal pull- down to V <sub>SS</sub>
Low Level Output Voltage (RXD)	V <sub>OLRXD</sub>	—	—	—	0.2V <sub>REG</sub>	V	I <sub>OL</sub> = 2 mA
High Level Output Voltage (RXD)	V <sub>OHRXD</sub>	0.8V <sub>REG</sub>	—	—	—	V	I <sub>OH</sub> = 2 mA
Low Level Output Voltage (FAULT/TXE)	V <sub>OLOD</sub>	—	—	—	1.0	V	I <sub>OL</sub> = 4 mA
Low Level Output Voltage (RESET)	V <sub>OLRST</sub>	—	—	—	1.0	V	I <sub>OL</sub> = 4 mA

# MCP2050

## 2.3 DC Specifications (Continued)

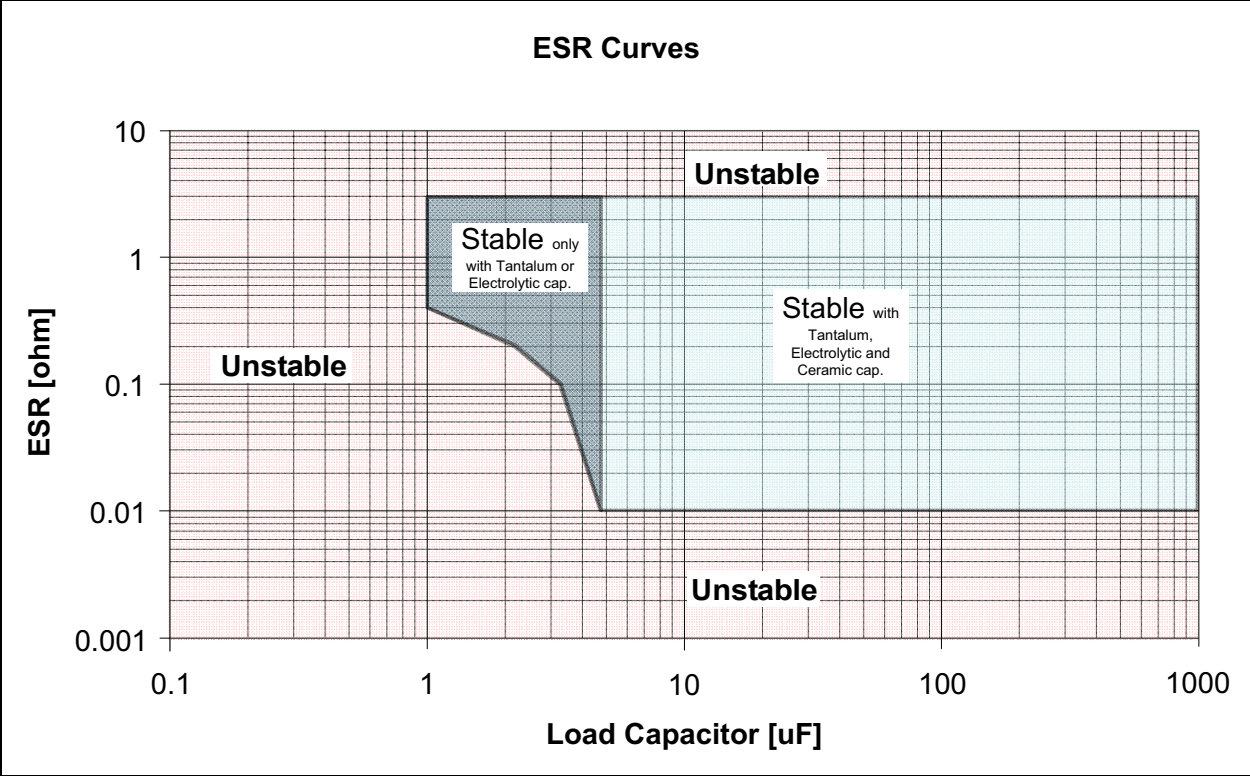
DC Specifications	Electrical Characteristics:					
	Unless otherwise indicated, all limits are specified for: V <sub>BB</sub> = 6.0V to 18.0V T <sub>A</sub> = -40°C to +125°C					
Parameter	Sym.	Min.	Typ.	Max.	Units	Conditions
<b>Bus Interface (DC specifications are for a V<sub>BB</sub> range of 6.0 to 18.0V)</b>						
High Level Input Voltage	V <sub>IH(LBUS)</sub>	0.6 V <sub>BB</sub>	—	—	V	Recessive state
Low Level Input Voltage	V <sub>IL(LBUS)</sub>	-8	—	0.4 V <sub>BB</sub>	V	Dominant state
Input Hysteresis	V <sub>HYS</sub>	—	—	0.175 V <sub>BB</sub>	V	V <sub>IH(LBUS)</sub> – V <sub>IL(LBUS)</sub>
Low Level Output Current	I <sub>OL(LBUS)</sub>	40	—	200	mA	Output voltage = 0.1 V <sub>BB</sub> , V <sub>BB</sub> = 12V
Pull-up Current on Input	I <sub>PU(LBUS)</sub>	-180	—	-72	μA	~30 kΩ internal pull-up @ V <sub>IH</sub> (LBUS) = 0.7 V <sub>BB</sub> , V <sub>BB</sub> =12V
Short Circuit Current Limit	I <sub>SC</sub>	50	—	200	mA	<b>(Note 1)</b>
High Level Output Voltage	V <sub>OH(LBUS)</sub>	0.8 V <sub>BB</sub>	—	V <sub>BB</sub>	V	
Driver Dominant Voltage	V <sub>_LOSUP</sub>	—	—	1.1	V	V <sub>BB</sub> = 7.3V, R <sub>LOAD</sub> = 1000Ω
Driver Dominant Voltage	V <sub>_HISUP</sub>	—	—	1.2	V	V <sub>BB</sub> = 18V, R <sub>LOAD</sub> = 1000Ω
Input Leakage Current (at the receiver during dominant bus level)	I <sub>BUS_PAS_</sub> DOM	-1	—	—	mA	Driver off, V <sub>BUS</sub> = 0V, V <sub>BB</sub> = 12V
Input Leakage Current (at the receiver during recessive bus level)	I <sub>BUS_PAS_</sub> REC	-20	—	20	μA	Driver off, 8V < V <sub>BB</sub> < 18V 8V < V <sub>BUS</sub> < 18V V <sub>BUS</sub> ≥ V <sub>BB</sub>
Leakage Current (disconnected from ground)	I <sub>BUS_NO_G</sub> ND	-10	—	+10	μA	GND <sub>DEVICE</sub> = V <sub>BB</sub> , 0V < V <sub>BUS</sub> < 18V, V <sub>BB</sub> = 12V
Leakage Current (disconnected from V <sub>BB</sub> )	I <sub>BUS_NO_P</sub> WR	-10	—	+10	μA	V <sub>BB</sub> = GND, 0 < V <sub>BUS</sub> < 18V
Receiver Center Voltage	V <sub>BUS_CNT</sub>	0.475 V <sub>BB</sub>	0.5 V <sub>BB</sub>	0.525 V <sub>BB</sub>	V	V <sub>BUS_CNT</sub> = (V <sub>IL</sub> (LBUS) + V <sub>IH</sub> (LBUS))/2
Slave Termination	R <sub>SLAVE</sub>	20	30	47	kΩ	<b>(Note 2)</b>
Capacitance of slave node	C <sub>SLAVE</sub>			50	pF	<b>(Note 2)</b>
Wake-Up Voltage Thresh- old on LIN Bus	V <sub>WK(LBUS)</sub>	—	—	3.4	V	Wake up from POWER- DOWN mode <b>(Note 3)</b>
<p><b>Note 1:</b> Internal current limited. 2.0 ms maximum recovery time (R<sub>LBUS</sub> = 0Ω, TX = 0, V<sub>LBUS</sub> = V<sub>BB</sub>).</p> <p><b>2:</b> For design guidance only, not tested.</p> <p><b>3:</b> In POWER DOWN mode, normal LIN recessive/dominant threshold is disabled; V<sub>WK(LBUS)</sub> is used to detect bus activities.</p>						

## 2.3 DC Specification (Continued)

DC Specifications	Electrical Characteristics:					
	Unless otherwise indicated, all limits are specified for: $V_{BB} = 6.0V$ to $18.0V$ $T_A = -40^{\circ}C$ to $+125^{\circ}C$ $C_{LOADREG} = 10 \mu F$					
Parameter	Sym.	Min.	Typ.	Max.	Units	Conditions
<b>Voltage Regulator - 5.0V</b>						
Output Voltage Range	$V_{REG}$	4.85	5.00	5.15	V	$0 \text{ mA} < I_{OUT} < 70 \text{ mA}$
Line Regulation	$\Delta V_{OUT1}$	—	10	50	mV	$I_{OUT} = 1 \text{ mA}$ , $6.0V < V_{BB} < 18V$
Load Regulation	$\Delta V_{OUT2}$	—	10	50	mV	$5 \text{ mA} < I_{OUT} < 70 \text{ mA}$ $6.0V < V_{BB} < 12V$
Power Supply Ripple Reject	PSRR	—	—	50	dB	$1 V_{PP}$ @10-20 kHz $I_{LOAD} = 20 \text{ mA}$
Output Noise Voltage	eN	—	—	100	$\mu V_{RMS}$	10 Hz – 40 MHz $C_{FILTER} = 10 \mu f$ , $C_{BP} = 0.1 \mu f$ , $I_{LOAD} = 20 \text{ mA}$
Shutdown Voltage Threshold	$V_{SD}$	3.5	—	4.0	V	See <a href="#">Figure 1-12 (Note 1)</a>
Input Voltage to Turn Off Output	$V_{OFF}$	3.9	—	4.5	V	
Input Voltage to Turn On Output	$V_{ON}$	5.25	—	6.0	V	
<b>Voltage Regulator - 3.3V</b>						
Output Voltage	$V_{REG}$	3.20	3.30	3.40	V	$0 \text{ mA} < I_{OUT} < 70 \text{ mA}$
Line Regulation	$\Delta V_{OUT1}$	—	10	50	mV	$I_{OUT} = 1 \text{ mA}$ , $6.0V < V_{BB} < 18V$
Load Regulation	$\Delta V_{OUT2}$	—	10	50	mV	$5 \text{ mA} < I_{OUT} < 70 \text{ mA}$ , $6.0V < V_{BB} < 12V$
Power Supply Ripple Reject	PSRR	—	—	50	dB	$1 V_{PP}$ @10-20 kHz , $I_{LOAD} = 20 \text{ mA}$
Output Noise Voltage	eN	—	—	100	$\mu V_{RMS} / \sqrt{Hz}$	10 Hz – 40 MHz $C_{FILTER} = 10 \mu f$ , $C_{BP} = 0.1 \mu f$ , $I_{LOAD} = 20 \text{ mA}$
Shutdown Voltage	$V_{SD}$	2.5	—	2.7	V	See <a href="#">Figure 1-12 (Note 1)</a>
Input Voltage to Turn Off Output	$V_{OFF}$	3.9	—	4.5	V	
Input Voltage to Turn On Output	$V_{ON}$	5.25	—	6	V	
<b>Note 1:</b> For design guidance only, not tested.						

# MCP2050

FIGURE 2-1: ESR CURVES FOR LOAD CAPACITOR SELECTION





## 2.4 AC Specification

AC CHARACTERISTICS		V <sub>BB</sub> = 6.0V to 18.0V; T <sub>A</sub> = -40°C to +125°C				
Parameter	Sym.	Min.	Typ.	Max.	Units	Test Conditions
<b>Bus Interface - Constant Slope Time Parameters (DC specifications are for a V<sub>BB</sub> range of 6.0 to 18.0V)</b>						
Slope rising and falling edges	t <sub>SLOPE</sub>	3.5	—	22.5	μs	7.3V ≤ V <sub>BB</sub> ≤ 18V
Propagation Delay of Transmitter	t <sub>TRANSPD</sub>	—	—	5.0	μs	t <sub>TRANSPD</sub> = max (t <sub>TRANSPDR</sub> or t <sub>TRANSPDF</sub> )
Propagation Delay of Receiver	t <sub>RECPD</sub>	—	—	6.0	μs	t <sub>RECPD</sub> = max (t <sub>RECPDR</sub> or t <sub>RECPDF</sub> )
Symmetry of Propagation Delay of Receiver rising edge w.r.t. falling edge	t <sub>RECSYM</sub>	-2.0	—	2.0	μs	t <sub>recsym</sub> = max (t <sub>RECPDF</sub> - t <sub>RECPDR</sub> ) RRXD 2.4 kΩ to V <sub>CC</sub> , CRXD 20pF
Symmetry of Propagation Delay of Transmitter rising edge w.r.t. falling edge	t <sub>TRANSSYM</sub>	-2.0	—	2.0	μs	t <sub>TRANSSYM</sub> = max (t <sub>TRANSPDF</sub> - t <sub>TRANSPDR</sub> )
Bus dominant time-out time	t <sub>TO(LIN)</sub>	—	25	—	mS	
Time to sample of FAULT/ TXE for bus conflict reporting	t <sub>FAULT</sub>	—	—	32.5	μs	t <sub>FAULT</sub> = max (t <sub>TRANSPD</sub> + t <sub>SLOPE</sub> + t <sub>RECPD</sub> )
Duty Cycle 1 @20.0 kbit/sec		.396	—	—	%t <sub>BIT</sub>	CBUS;RBUS conditions: 1 nF; 1 kΩ   6.8 nF; 660Ω   10 nF; 500Ω THREC(MAX) = 0.744 x V <sub>BB</sub> , THDOM(MAX) = 0.581 x V <sub>BB</sub> , V <sub>BB</sub> = 7.0V - 18V; t <sub>BIT</sub> = 50 μs. D1 = t <sub>BUS_REC</sub> (MIN) / 2 x t <sub>BIT</sub> )
Duty Cycle 2 @20.0 kbit/sec		—	—	.581	%t <sub>BIT</sub>	CBUS;RBUS conditions: 1 nF; 1 kΩ   6.8 nF; 660Ω   10 nF; 500Ω THREC(MAX) = 0.284 x V <sub>BB</sub> , THDOM(MAX) = 0.422 x V <sub>BB</sub> , V <sub>BB</sub> = 7.6V - 18V; t <sub>BIT</sub> = 50 μs. D2 = t <sub>BUS_REC</sub> (MAX) / 2 x t <sub>BIT</sub> )
Duty Cycle 3 @10.4 kbit/sec		.417	—	—	%t <sub>BIT</sub>	CBUS;RBUS conditions: 1 nF; 1 kΩ   6.8 nF; 660Ω   10 nF; 500Ω THREC(MAX) = 0.778 x V <sub>BB</sub> , THDOM(MAX) = 0.616 x V <sub>BB</sub> , V <sub>BB</sub> = 7.0V - 18V; t <sub>BIT</sub> = 96 μs. D3 = t <sub>BUS_REC</sub> (MIN) / 2 x t <sub>BIT</sub> )
Duty Cycle 4 @10.4 kbit/sec		—	—	.590	%t <sub>BIT</sub>	CBUS;RBUS conditions: 1 nF; 1 kΩ   6.8 nF; 660Ω   10 nF; 500Ω THREC(MAX) = 0.251 x V <sub>BB</sub> , THDOM(MAX) = 0.389 x V <sub>BB</sub> , V <sub>BB</sub> = 7.6V - 18V; t <sub>BIT</sub> = 96 μs. D4 = t <sub>BUS_REC</sub> (MAX) / 2 x t <sub>BIT</sub> )

# MCP2050

## 2.4 AC Specification (Continued)

AC CHARACTERISTICS		$V_{BB} = 6.0V$ to $18.0V$ ; $T_A = -40^{\circ}C$ to $+125^{\circ}C$				
Parameter	Sym.	Min.	Typ.	Max.	Units	Test Conditions
<b>Voltage Regulator</b>						
Bus Activity Debounce time	$t_{BDB}$	30	80	250	$\mu s$	
Bus Activity to Voltage Regulator Enabled	$t_{BACTIVE}$	35	—	200	$\mu s$	
Voltage Regulator Enabled to Ready	$t_{VEVR}$	300	—	1200	$\mu s$	(Note 1)
Chip Select to Ready Mode	$t_{CSR}$	—	—	230	$\mu s$	(Note 2)
Chip Select to Power-down	$t_{CSPD}$	—	—	300	$\mu s$	(Note 2)
Short circuit to shut-down	$t_{SHUTDOWN}$	20	—	100	$\mu s$	
<b>RESET Timing</b>						
VREG OK detect to RESET inactive	$t_{RPU}$	—	—	60.0	$\mu s$	(Note 2)
VREG not OK detect to RESET active	$t_{RPD}$	—	—	60.0	$\mu s$	(Note 2)

**Note 1:** Time depends on external capacitance and load. Test condition:  $C_{REG} = 4.7\mu F$ , no resistor load.

**2:** For design guidance only, not tested.

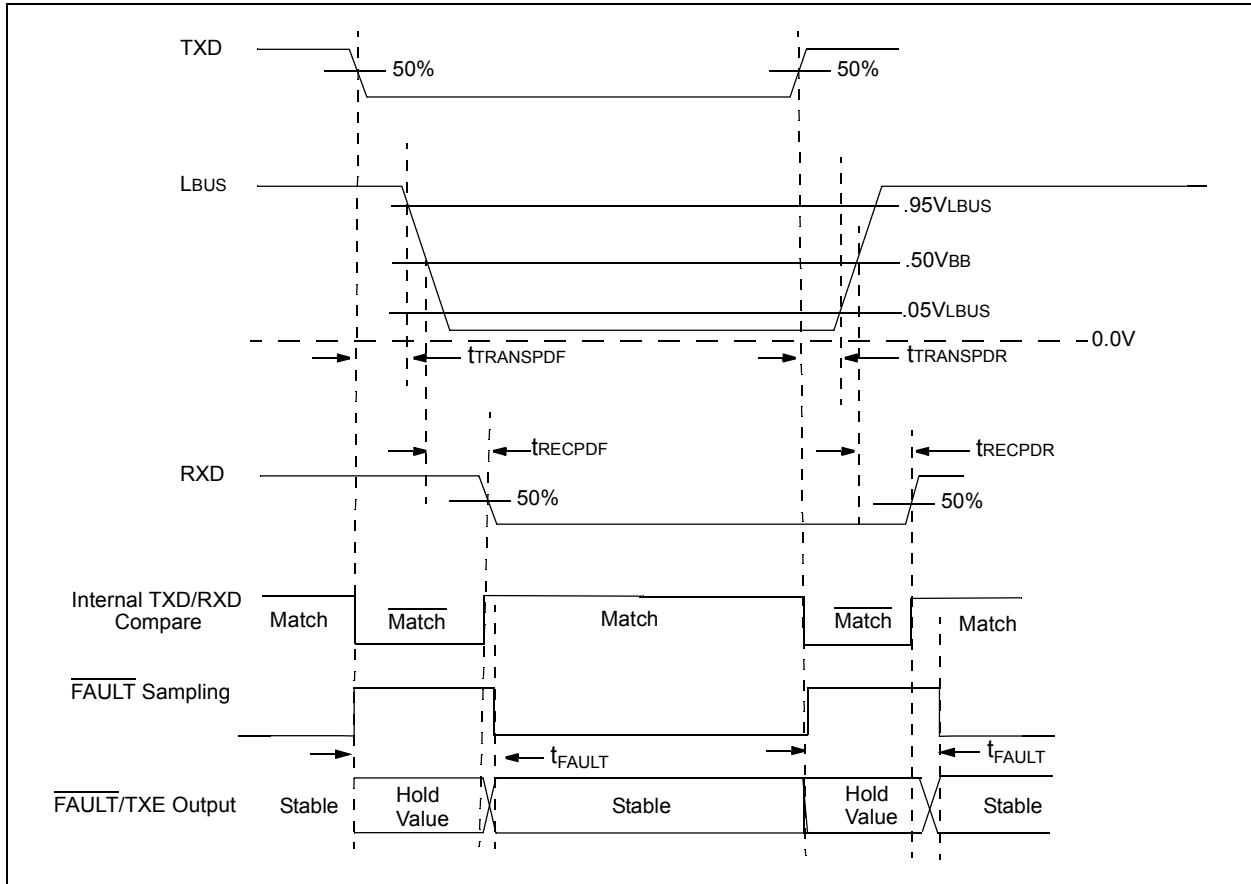
## 2.5 Thermal Specifications

THERMAL CHARACTERISTICS					
Parameter	Symbol	Typ	Max	Units	Test Conditions
Recovery Temperature	$\theta_{RECOVERY}$	+140	—	$^{\circ}C$	
Shutdown Temperature	$\theta_{SHUTDOWN}$	+150	—	$^{\circ}C$	
Short Circuit Recovery Time	$t_{THERM}$	1.5	5.0	ms	
<b>Thermal Package Resistances</b>					
Thermal Resistance, 14L-PDIP	$\theta_{JA}$	70	—	$^{\circ}C/W$	
Thermal Resistance, 14L-SOIC	$\theta_{JA}$	95.3	—	$^{\circ}C/W$	
Thermal Resistance, 20L-QFN	$\theta_{JA}$	36.1	—	$^{\circ}C/W$	

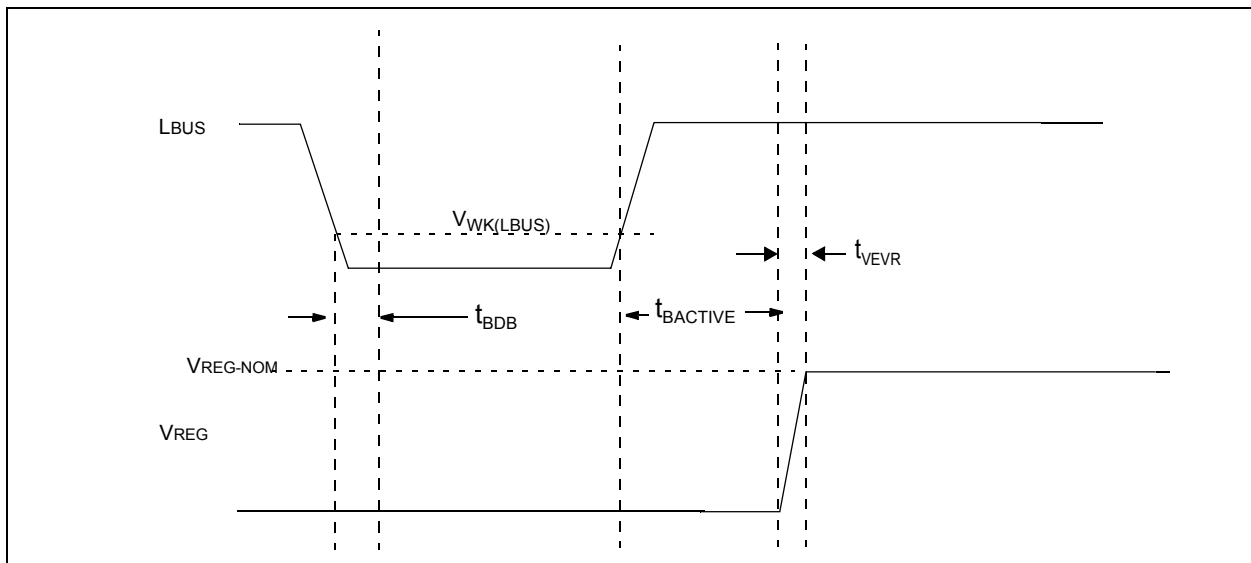
**Note 1:** The maximum power dissipation is a function of  $T_{JMAX}$ ,  $\theta_{JA}$  and ambient temperature  $T_A$ . The maximum allowable power dissipation at an ambient temperature is  $P_D = (T_{JMAX} - T_A) \theta_{JA}$ . If this dissipation is exceeded, the die temperature will rise above  $150^{\circ}C$  and the MCP2050 will go into thermal shutdown.

## 2.6 Timing Diagrams and Specifications

**FIGURE 2-2: BUS TIMING DIAGRAM**

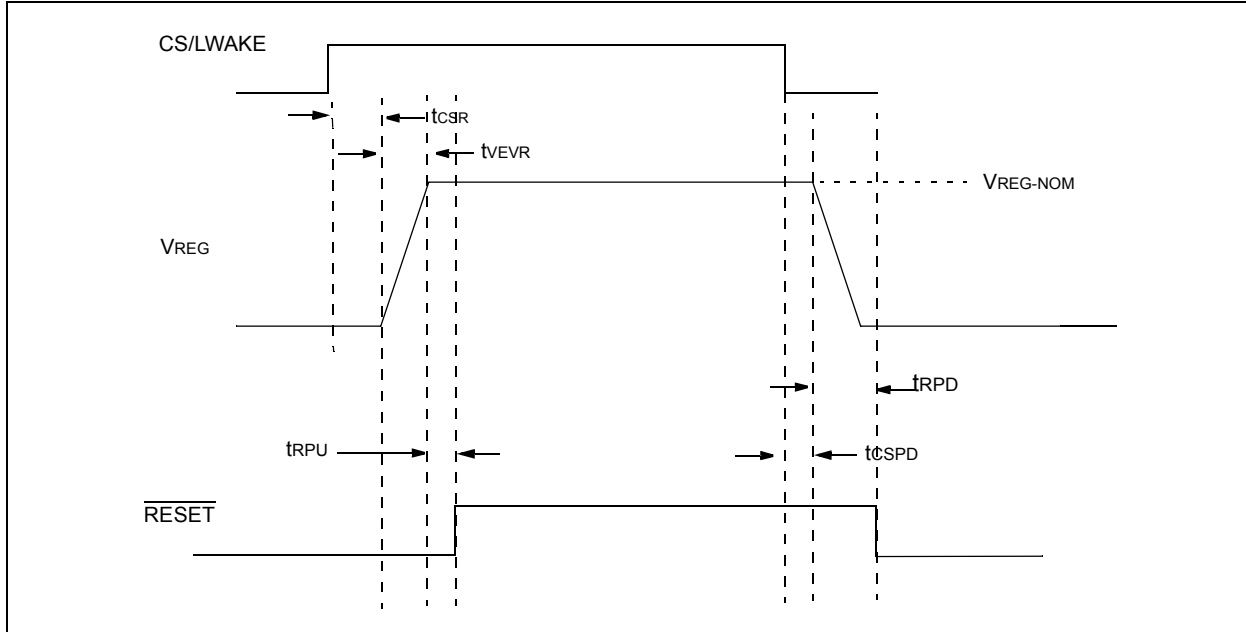


**FIGURE 2-3: REGULATOR BUS WAKE TIMING DIAGRAM**

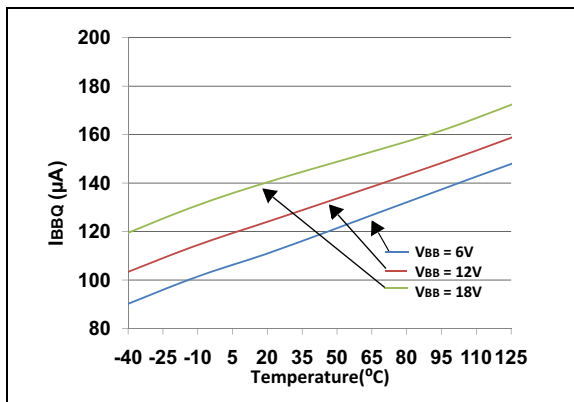


# MCP2050

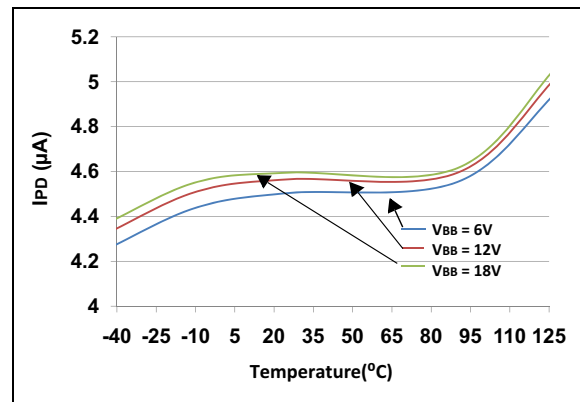
**FIGURE 2-4: CS/LWAKE, REGULATOR AND RESET TIMING DIAGRAM**



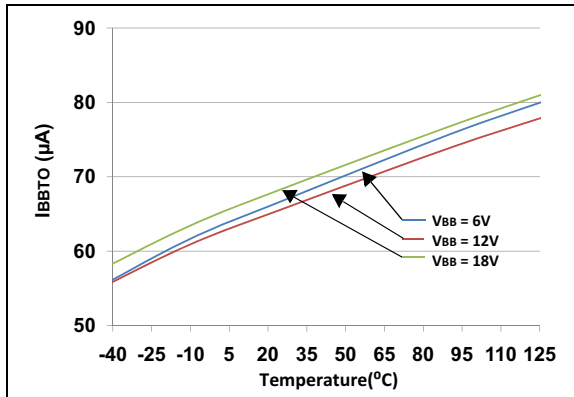
**FIGURE 2-5: TYPICAL  $I_{BBQ}$  VS. TEMPERATURE - 5.0V**



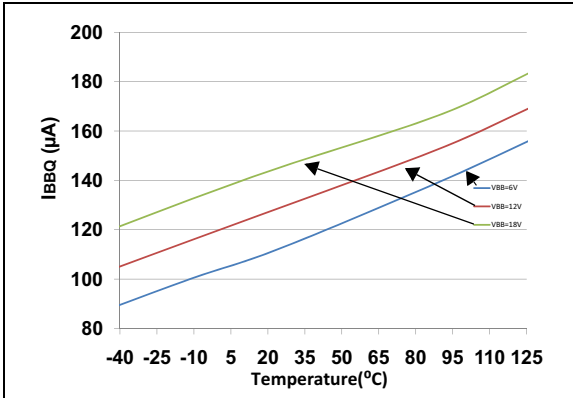
**FIGURE 2-7: TYPICAL  $I_{PD}$  VS. TEMPERATURE - 5.0V**



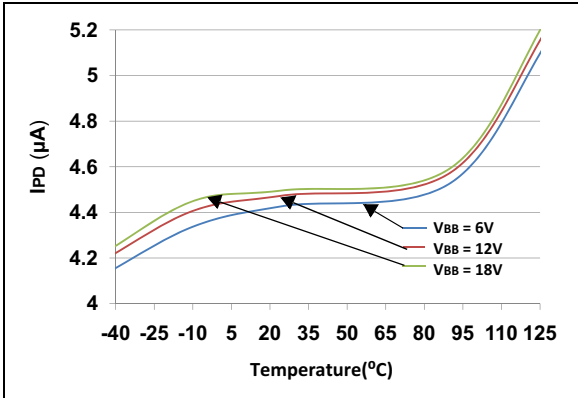
**FIGURE 2-6: TYPICAL  $I_{BBTO}$  VS. TEMPERATURE - 5.0V**



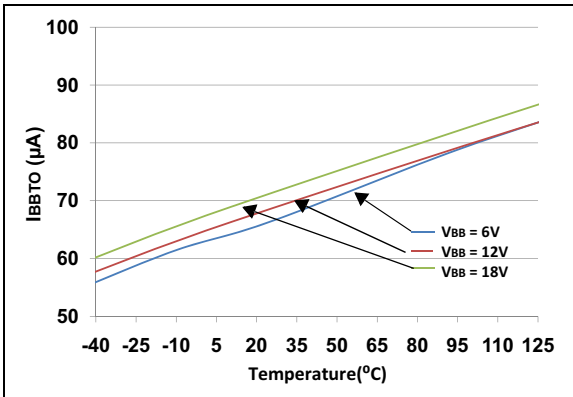
**FIGURE 2-8: TYPICAL  $I_{BBQ}$  VS. TEMPERATURE - 3.3V**



**FIGURE 2-10: TYPICAL  $I_{PD}$  VS. TEMPERATURE - 3.3V**



**FIGURE 2-9: TYPICAL  $I_{BBTO}$  VS. TEMPERATURE - 3.3V**



# MCP2050

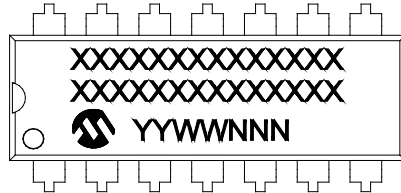
---

NOTES:

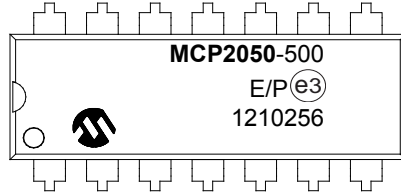
## 3.0 PACKAGING INFORMATION

### 3.1 Package Marking Information

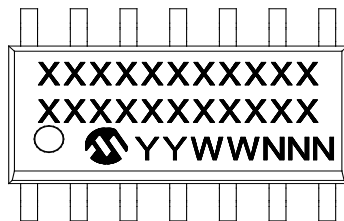
14-Lead PDIP (300 mil)



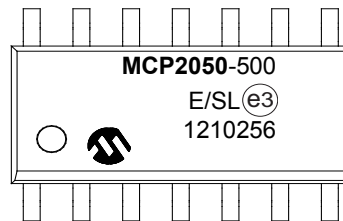
Example



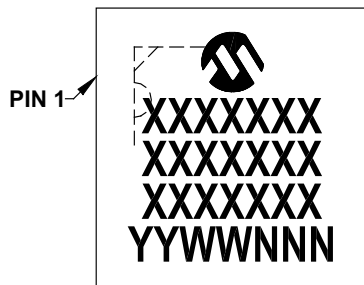
14-Lead SOIC (.150")



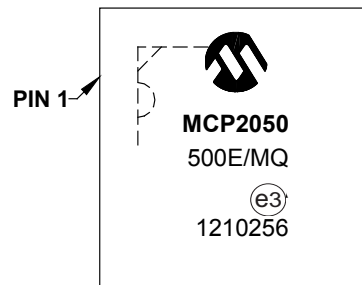
Example



20-Lead QFN (5x5x0.9 mm)



Example



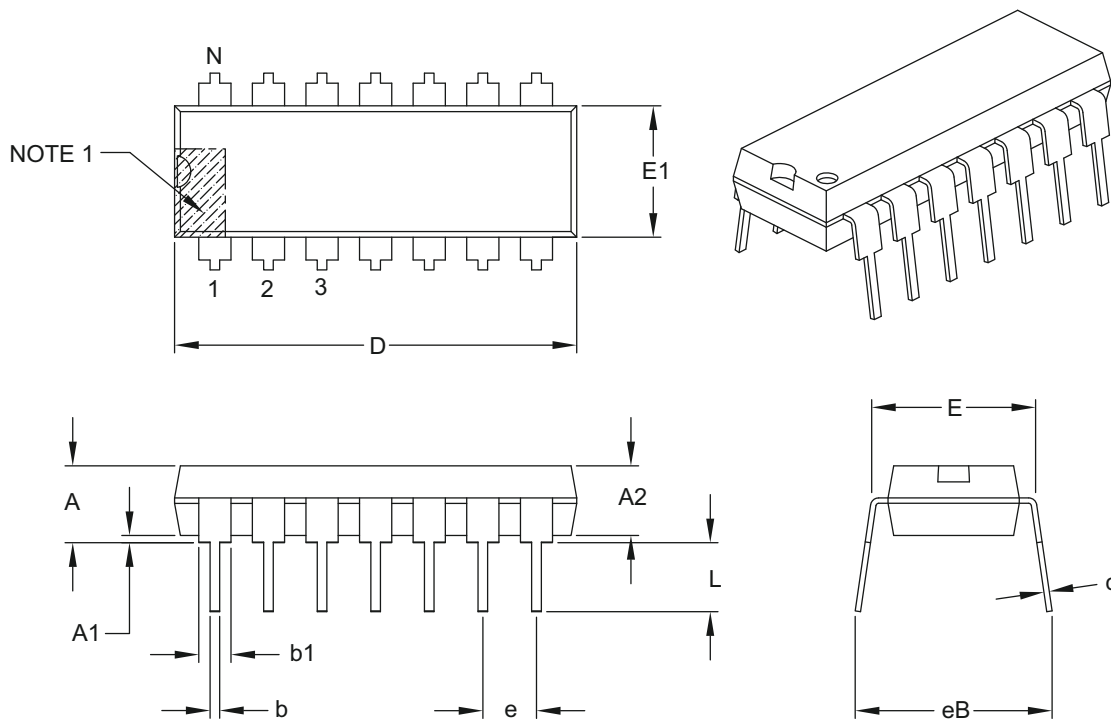
<b>Legend:</b>	XX...X	Customer-specific information
	Y	Year code (last digit of calendar year)
	YY	Year code (last 2 digits of calendar year)
	WW	Week code (week of January 1 is week '01')
	NNN	Alphanumeric traceability code
	(e3)	Pb-free JEDEC designator for Matte Tin (Sn)
	*	This package is Pb-free. The Pb-free JEDEC designator (e3) can be found on the outer packaging for this package.

**Note:** In the event the full Microchip part number cannot be marked on one line, it will be carried over to the next line, thus limiting the number of available characters for customer-specific information.

# MCP2050

## 14-Lead Plastic Dual In-Line (P) – 300 mil Body [PDIP]

**Note:** For the most current package drawings, please see the Microchip Packaging Specification located at <http://www.microchip.com/packaging>



Dimension Limits	Units	INCHES		
		MIN	NOM	MAX
Number of Pins	N	14		
Pitch	e	.100 BSC		
Top to Seating Plane	A	–	–	.210
Molded Package Thickness	A2	.115	.130	.195
Base to Seating Plane	A1	.015	–	–
Shoulder to Shoulder Width	E	.290	.310	.325
Molded Package Width	E1	.240	.250	.280
Overall Length	D	.735	.750	.775
Tip to Seating Plane	L	.115	.130	.150
Lead Thickness	c	.008	.010	.015
Upper Lead Width	b1	.045	.060	.070
Lower Lead Width	b	.014	.018	.022
Overall Row Spacing §	eB	–	–	.430

**Notes:**

- Pin 1 visual index feature may vary, but must be located with the hatched area.
- § Significant Characteristic.
- Dimensions D and E1 do not include mold flash or protrusions. Mold flash or protrusions shall not exceed .010" per side.
- Dimensioning and tolerancing per ASME Y14.5M.

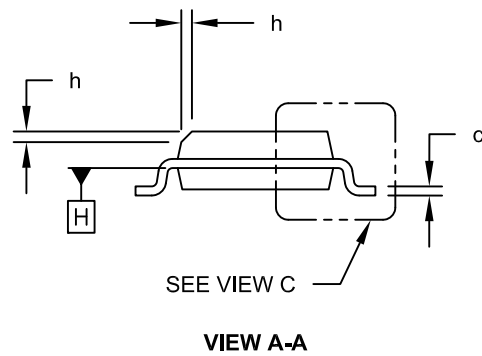
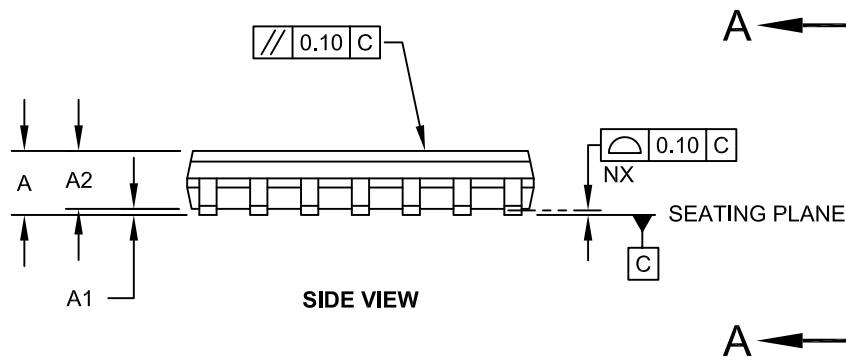
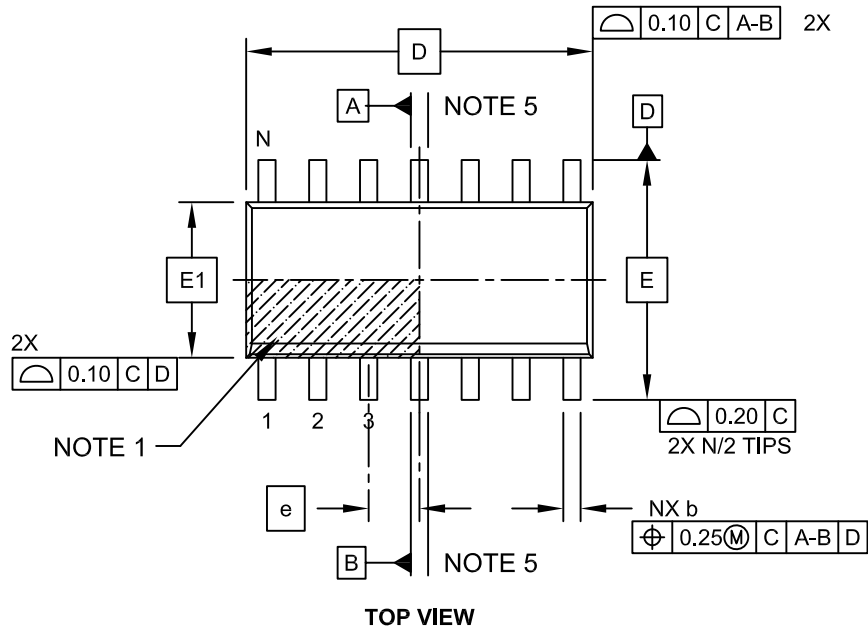
BSC: Basic Dimension. Theoretically exact value shown without tolerances.

Microchip Technology Drawing C04-005B



## 14-Lead Plastic Small Outline (SL) - Narrow, 3.90 mm Body [SOIC]

**Note:** For the most current package drawings, please see the Microchip Packaging Specification located at <http://www.microchip.com/packaging>

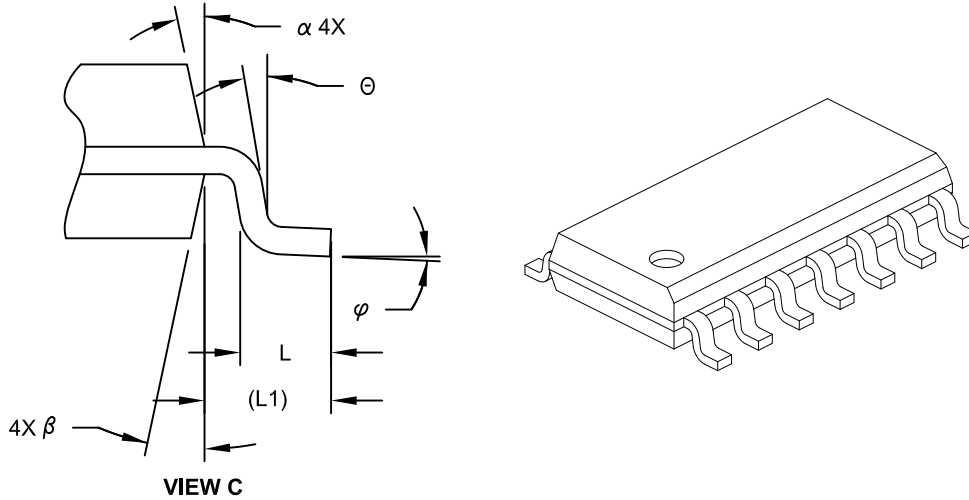


Microchip Technology Drawing No. C04-065C Sheet 1 of 2

# MCP2050

## 14-Lead Plastic Small Outline (SL) - Narrow, 3.90 mm Body [SOIC]

**Note:** For the most current package drawings, please see the Microchip Packaging Specification located at <http://www.microchip.com/packaging>



Dimension Limits	Units	MILLIMETERS		
		MIN	NOM	MAX
Number of Pins	N	14		
Pitch	e	1.27 BSC		
Overall Height	A	-	-	1.75
Molded Package Thickness	A2	1.25	-	-
Standoff §	A1	0.10	-	0.25
Overall Width	E	6.00 BSC		
Molded Package Width	E1	3.90 BSC		
Overall Length	D	8.65 BSC		
Chamfer (Optional)	h	0.25	-	0.50
Foot Length	L	0.40	-	1.27
Footprint	L1	1.04 REF		
Lead Angle	Θ	0°	-	-
Foot Angle	φ	0°	-	8°
Lead Thickness	c	0.10	-	0.25
Lead Width	b	0.31	-	0.51
Mold Draft Angle Top	α	5°	-	15°
Mold Draft Angle Bottom	β	5°	-	15°

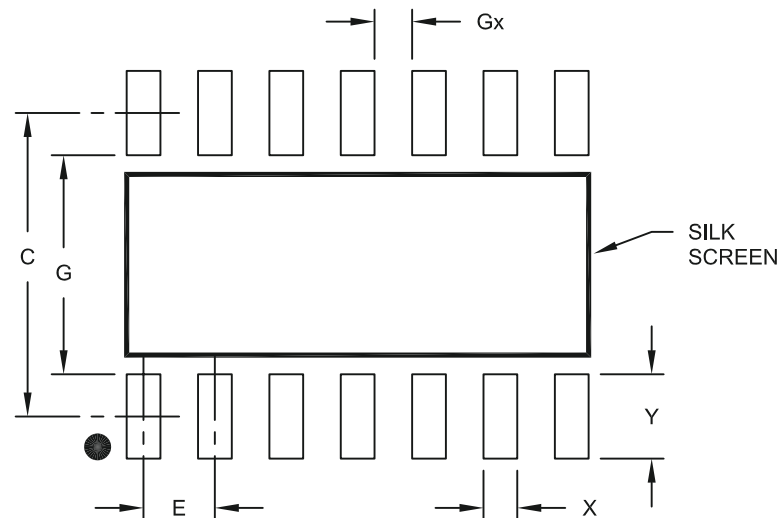
**Notes:**

- Pin 1 visual index feature may vary, but must be located within the hatched area.
- § Significant Characteristic
- Dimension D does not include mold flash, protrusions or gate burrs, which shall not exceed 0.15 mm per end. Dimension E1 does not include interlead flash or protrusion, which shall not exceed 0.25 mm per side.
- Dimensioning and tolerancing per ASME Y14.5M  
 BSC: Basic Dimension. Theoretically exact value shown without tolerances.  
 REF: Reference Dimension, usually without tolerance, for information purposes only.
- Datums A & B to be determined at Datum H.

Microchip Technology Drawing No. C04-065C Sheet 2 of 2

## 14-Lead Plastic Small Outline (SL) - Narrow, 3.90 mm Body [SOIC]

**Note:** For the most current package drawings, please see the Microchip Packaging Specification located at <http://www.microchip.com/packaging>



RECOMMENDED LAND PATTERN

Dimension Limits	Units	MILLIMETERS		
		MIN	NOM	MAX
Contact Pitch	E	1.27 BSC		
Contact Pad Spacing	C		5.40	
Contact Pad Width	X			0.60
Contact Pad Length	Y			1.50
Distance Between Pads	Gx	0.67		
Distance Between Pads	G	3.90		

**Notes:**

1. Dimensioning and tolerancing per ASME Y14.5M

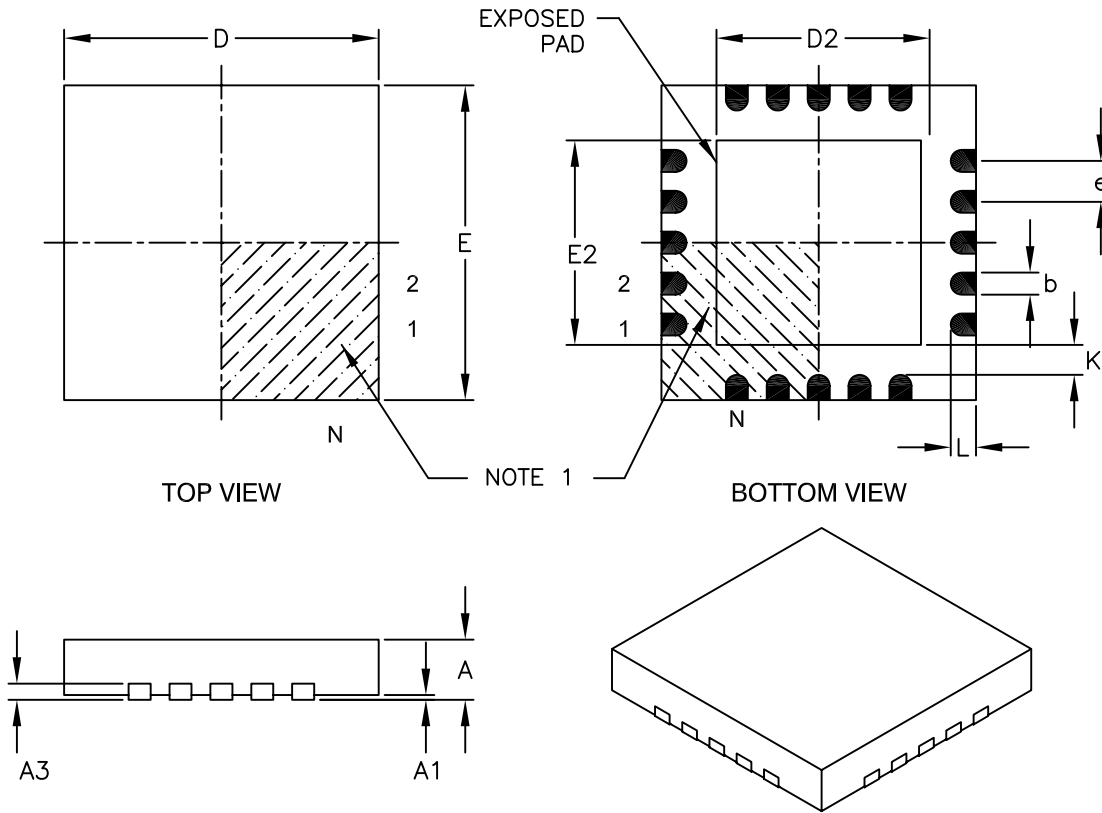
BSC: Basic Dimension. Theoretically exact value shown without tolerances.

Microchip Technology Drawing No. C04-2065A

# MCP2050

## 20-Lead Plastic Quad Flat, No Lead Package (MQ) – 5x5x0.9 mm Body [QFN]

**Note:** For the most current package drawings, please see the Microchip Packaging Specification located at <http://www.microchip.com/packaging>



Dimension Limits	Units	MILLIMETERS		
		MIN	NOM	MAX
Number of Pins	N	20		
Pitch	e	0.65 BSC		
Overall Height	A	0.80	0.90	1.00
Standoff	A1	0.00	0.02	0.05
Contact Thickness	A3	0.20 REF		
Overall Width	E	5.00 BSC		
Exposed Pad Width	E2	3.15	3.25	3.35
Overall Length	D	5.00 BSC		
Exposed Pad Length	D2	3.15	3.25	3.35
Contact Width	b	0.25	0.30	0.35
Contact Length	L	0.35	0.40	0.45
Contact-to-Exposed Pad	K	0.20	-	-

**Notes:**

- Pin 1 visual index feature may vary, but must be located within the hatched area.
- Package is saw singulated.
- Dimensioning and tolerancing per ASME Y14.5M.

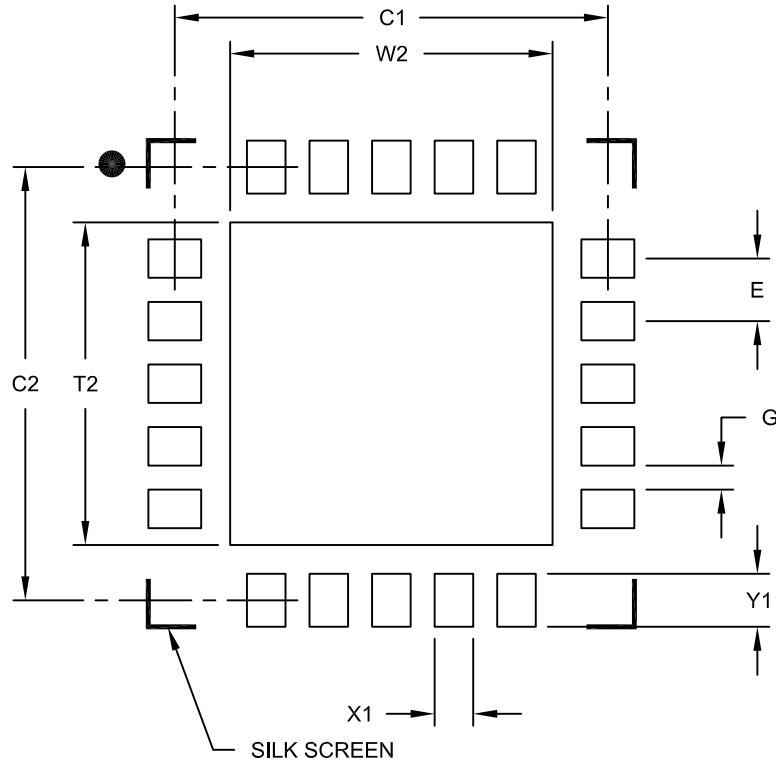
BSC: Basic Dimension. Theoretically exact value shown without tolerances.

REF: Reference Dimension, usually without tolerance, for information purposes only.

Microchip Technology Drawing C04-139B

20-Lead Plastic Quad Flat, No Lead Package (MQ) - 5x5 mm Body [QFN]  
With 0.40mm Contact Length

**Note:** For the most current package drawings, please see the Microchip Packaging Specification located at <http://www.microchip.com/packaging>



RECOMMENDED LAND PATTERN

Dimension Limits	Units	MILLIMETERS		
		MIN	NOM	MAX
Contact Pitch	E	0.65 BSC		
Optional Center Pad Width	W2			3.35
Optional Center Pad Length	T2			3.35
Contact Pad Spacing	C1		4.50	
Contact Pad Spacing	C2		4.50	
Contact Pad Width (X20)	X1			0.40
Contact Pad Length (X20)	Y1			0.55
Distance Between Pads	G	0.20		

Notes:

1. Dimensioning and tolerancing per ASME Y14.5M

BSC: Basic Dimension. Theoretically exact value shown without tolerances.

Microchip Technology Drawing No. C04-2139A

# MCP2050

---

NOTES:

## APPENDIX A: REVISION HISTORY

### Revision B (April 2012)

- Corrected a label in Figure 1-14 (I/O to IRQ).
- Corrected a label in Figure 1-15 (MCP202XA to MCP2050).
- Corrected data on the Product Identification System page.

### Revision A (March 2012)

Original release of this document.

# MCP2050

---

NOTES:



## PRODUCT IDENTIFICATION SYSTEM

To order or obtain information, e.g., on pricing or delivery, refer to the factory or the listed sales office.

<u>PART NO.</u>	<u>-X</u>	<u>/XX</u>	
Device	Temperature Range	Package	
Device:	MCP2050:	LIN Transceiver with Voltage Regulator	
	MCP2050T:	LIN Transceiver with Voltage Regulator (Tape and Reel) (SOIC and QFN only)	
Temperature Range:	E	= -40°C to +125°C	
Package:	P	= Plastic DIP (300 mil Body), 14-lead	
	SL	= Plastic SOIC, (150 mil Body), 14-lead	
	MQ	= Plastic QFN, (5x5x0.9 mm Body), 20-lead	
<b>Examples:</b>			
a)	MCP2050-330E/P:	3.3V, 14L-PDIP package	
b)	MCP2050-330E/SL:	3.3V, 14L-SOIC package	
c)	MCP2050-330E/MQ:	3.3V, 20L-QFN package	
d)	MCP2050T-330E/SL:	Tape and Reel, 3.3V, 14L-SOIC package	
e)	MCP2050T-330E/MQ:	Tape and Reel, 3.3V, 20L-QFN package	
f)	MCP2050-500E/P:	5.0V, 14L-PDIP package	
g)	MCP2050-500E/SL:	5.0V, 14L-SOIC package	
h)	MCP2050-500E/MQ:	5.0V, 20L-QFN package	
i)	MCP2050T-500E/SL:	Tape and Reel, 5.0V, 14L-SOIC package	
j)	MCP2050T-500E/MQ:	Tape and Reel, 5.0V, 20L-QFN package	

# MCP2050

---

NOTES:

---

**Note the following details of the code protection feature on Microchip devices:**

- Microchip products meet the specification contained in their particular Microchip Data Sheet.
- Microchip believes that its family of products is one of the most secure families of its kind on the market today, when used in the intended manner and under normal conditions.
- There are dishonest and possibly illegal methods used to breach the code protection feature. All of these methods, to our knowledge, require using the Microchip products in a manner outside the operating specifications contained in Microchip's Data Sheets. Most likely, the person doing so is engaged in theft of intellectual property.
- Microchip is willing to work with the customer who is concerned about the integrity of their code.
- Neither Microchip nor any other semiconductor manufacturer can guarantee the security of their code. Code protection does not mean that we are guaranteeing the product as “unbreakable.”

Code protection is constantly evolving. We at Microchip are committed to continuously improving the code protection features of our products. Attempts to break Microchip's code protection feature may be a violation of the Digital Millennium Copyright Act. If such acts allow unauthorized access to your software or other copyrighted work, you may have a right to sue for relief under that Act.

---

Information contained in this publication regarding device applications and the like is provided only for your convenience and may be superseded by updates. It is your responsibility to ensure that your application meets with your specifications. MICROCHIP MAKES NO REPRESENTATIONS OR WARRANTIES OF ANY KIND WHETHER EXPRESS OR IMPLIED, WRITTEN OR ORAL, STATUTORY OR OTHERWISE, RELATED TO THE INFORMATION, INCLUDING BUT NOT LIMITED TO ITS CONDITION, QUALITY, PERFORMANCE, MERCHANTABILITY OR FITNESS FOR PURPOSE. Microchip disclaims all liability arising from this information and its use. Use of Microchip devices in life support and/or safety applications is entirely at the buyer's risk, and the buyer agrees to defend, indemnify and hold harmless Microchip from any and all damages, claims, suits, or expenses resulting from such use. No licenses are conveyed, implicitly or otherwise, under any Microchip intellectual property rights.

**Trademarks**

The Microchip name and logo, the Microchip logo, dsPIC, KEELOQ, KEELOQ logo, MPLAB, PIC, PICmicro, PICSTART, PIC<sup>32</sup> logo, rPIC and UNI/O are registered trademarks of Microchip Technology Incorporated in the U.S.A. and other countries.

FilterLab, Hampshire, HI-TECH C, Linear Active Thermistor, MXDEV, MXLAB, SEEVAL and The Embedded Control Solutions Company are registered trademarks of Microchip Technology Incorporated in the U.S.A.

Analog-for-the-Digital Age, Application Maestro, chipKIT, chipKIT logo, CodeGuard, dsPICDEM, dsPICDEM.net, dsPICworks, dsSPEAK, ECAN, ECONOMONITOR, FanSense, HI-TIDE, In-Circuit Serial Programming, ICSP, Mindi, MiWi, MPASM, MPLAB Certified logo, MPLIB, MPLINK, mTouch, Omniscient Code Generation, PICC, PICC-18, PICDEM, PICDEM.net, PICKit, PICtail, REAL ICE, rLAB, Select Mode, Total Endurance, TSHARC, UniWinDriver, WiperLock and ZENA are trademarks of Microchip Technology Incorporated in the U.S.A. and other countries.

SQTP is a service mark of Microchip Technology Incorporated in the U.S.A.

All other trademarks mentioned herein are property of their respective companies.

© 2012, Microchip Technology Incorporated, Printed in the U.S.A., All Rights Reserved.

 Printed on recycled paper.

ISBN: 978-1-62076-232-5

**QUALITY MANAGEMENT SYSTEM  
CERTIFIED BY DNV  
= ISO/TS 16949 =**

*Microchip received ISO/TS-16949:2009 certification for its worldwide headquarters, design and wafer fabrication facilities in Chandler and Tempe, Arizona; Gresham, Oregon and design centers in California and India. The Company's quality system processes and procedures are for its PIC<sup>®</sup> MCUs and dsPIC<sup>®</sup> DSCs, KEELOQ<sup>®</sup> code hopping devices, Serial EEPROMs, microperipherals, nonvolatile memory and analog products. In addition, Microchip's quality system for the design and manufacture of development systems is ISO 9001:2000 certified.*



# MICROCHIP

## Worldwide Sales and Service

### AMERICAS

**Corporate Office**  
2355 West Chandler Blvd.  
Chandler, AZ 85224-6199  
Tel: 480-792-7200  
Fax: 480-792-7277  
Technical Support:  
<http://www.microchip.com/support>  
Web Address:  
[www.microchip.com](http://www.microchip.com)

**Atlanta**  
Duluth, GA  
Tel: 678-957-9614  
Fax: 678-957-1455

**Boston**  
Westborough, MA  
Tel: 774-760-0087  
Fax: 774-760-0088

**Chicago**  
Itasca, IL  
Tel: 630-285-0071  
Fax: 630-285-0075

**Cleveland**  
Independence, OH  
Tel: 216-447-0464  
Fax: 216-447-0643

**Dallas**  
Addison, TX  
Tel: 972-818-7423  
Fax: 972-818-2924

**Detroit**  
Farmington Hills, MI  
Tel: 248-538-2250  
Fax: 248-538-2260

**Indianapolis**  
Noblesville, IN  
Tel: 317-773-8323  
Fax: 317-773-5453

**Los Angeles**  
Mission Viejo, CA  
Tel: 949-462-9523  
Fax: 949-462-9608

**Santa Clara**  
Santa Clara, CA  
Tel: 408-961-6444  
Fax: 408-961-6445

**Toronto**  
Mississauga, Ontario,  
Canada  
Tel: 905-673-0699  
Fax: 905-673-6509

### ASIA/PACIFIC

**Asia Pacific Office**  
Suites 3707-14, 37th Floor  
Tower 6, The Gateway  
Harbour City, Kowloon  
Hong Kong  
Tel: 852-2401-1200  
Fax: 852-2401-3431

**Australia - Sydney**  
Tel: 61-2-9868-6733  
Fax: 61-2-9868-6755

**China - Beijing**  
Tel: 86-10-8569-7000  
Fax: 86-10-8528-2104

**China - Chengdu**  
Tel: 86-28-8665-5511  
Fax: 86-28-8665-7889

**China - Chongqing**  
Tel: 86-23-8980-9588  
Fax: 86-23-8980-9500

**China - Hangzhou**  
Tel: 86-571-2819-3187  
Fax: 86-571-2819-3189

**China - Hong Kong SAR**  
Tel: 852-2401-1200  
Fax: 852-2401-3431

**China - Nanjing**  
Tel: 86-25-8473-2460  
Fax: 86-25-8473-2470

**China - Qingdao**  
Tel: 86-532-8502-7355  
Fax: 86-532-8502-7205

**China - Shanghai**  
Tel: 86-21-5407-5533  
Fax: 86-21-5407-5066

**China - Shenyang**  
Tel: 86-24-2334-2829  
Fax: 86-24-2334-2393

**China - Shenzhen**  
Tel: 86-755-8203-2660  
Fax: 86-755-8203-1760

**China - Wuhan**  
Tel: 86-27-5980-5300  
Fax: 86-27-5980-5118

**China - Xian**  
Tel: 86-29-8833-7252  
Fax: 86-29-8833-7256

**China - Xiamen**  
Tel: 86-592-2388138  
Fax: 86-592-2388130

**China - Zhuhai**  
Tel: 86-756-3210040  
Fax: 86-756-3210049

### ASIA/PACIFIC

**India - Bangalore**  
Tel: 91-80-3090-4444  
Fax: 91-80-3090-4123

**India - New Delhi**  
Tel: 91-11-4160-8631  
Fax: 91-11-4160-8632

**India - Pune**  
Tel: 91-20-2566-1512  
Fax: 91-20-2566-1513

**Japan - Osaka**  
Tel: 81-66-152-7160  
Fax: 81-66-152-9310

**Japan - Yokohama**  
Tel: 81-45-471-6166  
Fax: 81-45-471-6122

**Korea - Daegu**  
Tel: 82-53-744-4301  
Fax: 82-53-744-4302

**Korea - Seoul**  
Tel: 82-2-554-7200  
Fax: 82-2-558-5932 or  
82-2-558-5934

**Malaysia - Kuala Lumpur**  
Tel: 60-3-6201-9857  
Fax: 60-3-6201-9859

**Malaysia - Penang**  
Tel: 60-4-227-8870  
Fax: 60-4-227-4068

**Philippines - Manila**  
Tel: 63-2-634-9065  
Fax: 63-2-634-9069

**Singapore**  
Tel: 65-6334-8870  
Fax: 65-6334-8850

**Taiwan - Hsin Chu**  
Tel: 886-3-5778-366  
Fax: 886-3-5770-955

**Taiwan - Kaohsiung**  
Tel: 886-7-536-4818  
Fax: 886-7-330-9305

**Taiwan - Taipei**  
Tel: 886-2-2500-6610  
Fax: 886-2-2508-0102

**Thailand - Bangkok**  
Tel: 66-2-694-1351  
Fax: 66-2-694-1350

### EUROPE

**Austria - Wels**  
Tel: 43-7242-2244-39  
Fax: 43-7242-2244-393

**Denmark - Copenhagen**  
Tel: 45-4450-2828  
Fax: 45-4485-2829

**France - Paris**  
Tel: 33-1-69-53-63-20  
Fax: 33-1-69-30-90-79

**Germany - Munich**  
Tel: 49-89-627-144-0  
Fax: 49-89-627-144-44

**Italy - Milan**  
Tel: 39-0331-742611  
Fax: 39-0331-466781

**Netherlands - Drunen**  
Tel: 31-416-690399  
Fax: 31-416-690340

**Spain - Madrid**  
Tel: 34-91-708-08-90  
Fax: 34-91-708-08-91

**UK - Wokingham**  
Tel: 44-118-921-5869  
Fax: 44-118-921-5820

11/29/11



## Стандарт Электрон Связь

Мы молодая и активно развивающаяся компания в области поставок электронных компонентов. Мы поставляем электронные компоненты отечественного и импортного производства напрямую от производителей и с крупнейших складов мира.

Благодаря сотрудничеству с мировыми поставщиками мы осуществляем комплексные и плановые поставки широчайшего спектра электронных компонентов.

Собственная эффективная логистика и склад в обеспечивает надежную поставку продукции в точно указанные сроки по всей России.

Мы осуществляем техническую поддержку нашим клиентам и предпродажную проверку качества продукции. На все поставляемые продукты мы предоставляем гарантию .

Осуществляем поставки продукции под контролем ВП МО РФ на предприятия военно-промышленного комплекса России , а также работаем в рамках 275 ФЗ с открытием отдельных счетов в уполномоченном банке. Система менеджмента качества компании соответствует требованиям ГОСТ ISO 9001.

Минимальные сроки поставки, гибкие цены, неограниченный ассортимент и индивидуальный подход к клиентам являются основой для выстраивания долгосрочного и эффективного сотрудничества с предприятиями радиоэлектронной промышленности, предприятиями ВПК и научно-исследовательскими институтами России.

С нами вы становитесь еще успешнее!

### Наши контакты:

**Телефон:** +7 812 627 14 35

**Электронная почта:** [sales@st-electron.ru](mailto:sales@st-electron.ru)

**Адрес:** 198099, Санкт-Петербург,  
Промышленная ул, дом № 19, литера Н,  
помещение 100-Н Офис 331