

Flexis 32-bit Microcontrollers

MCF51JE256/128

Ultra-low-power MCU with USB connectivity



Target Applications

- HVAC building control systems
- PC peripherals
- Lighting control systems
- Industrial networking products
- Portable medical devices

Overview

The MCF51JE256/128 (JE256/128) provides ultra-low-power operation, USB connectivity and high measurement accuracy, all in a single 32-bit microcontroller, allowing designers to develop a more fully featured system at a lower cost. The JE256/128 integrates high-resolution ADC and DAC modules and a rich peripheral set including a USB 2.0 host/device/OTG controller, multiple serial interfaces and an external bus interface.

The JE256/128 is part of the Freescale Flexis microcontroller series, which includes both 8-bit S08 and 32-bit V1 ColdFire microcontrollers that have a common set of peripherals and development tools to deliver the ultimate in migration flexibility. The JE256/128 family is also easy to use. Freescale provides a comprehensive suite of development tools and software to help developers design quickly and easily.

MCF51JE256 Block Diagram

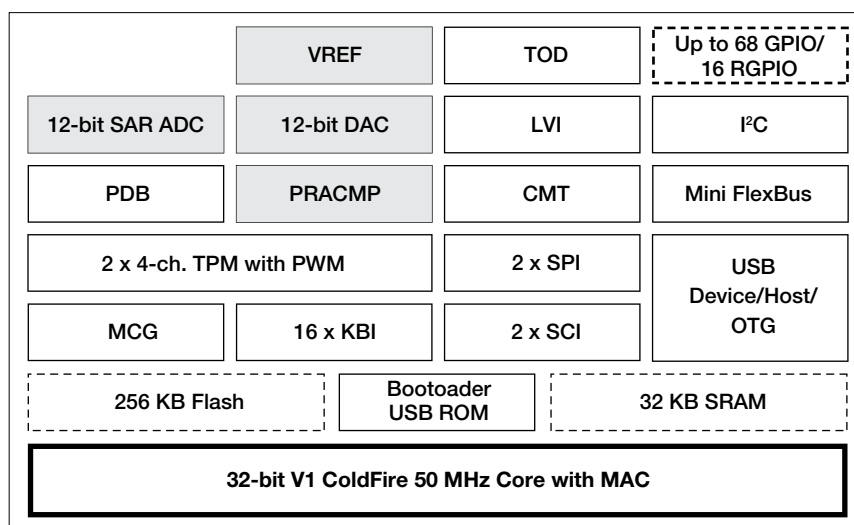

Modular Tower Development System

TWR-MCF51JE-KIT (\$119 USD*)

TWR-MCF51JE (\$69 USD*)

The Freescale Tower development system provides the user with a modular, reconfigurable demonstration and development platform.

The TWR-MCF51JE-KIT soldered with 100LQFP MCF51JE256 consists of:

- TWR-MCF51JE stand-alone development board
- TWR-SER serial boards that support USB and RS232
- TWR-ELEV elevator board that connects the MCU and serial boards
- USB cable

The TWR-MCF51JE can also be ordered independently. A getting-started DVD included with the board includes necessary software, documents and resources to jumpstart new product development.

CodeWarrior Development Studio for Microcontrollers v6.3/10.x

Special Edition (Complimentary**)

CodeWarrior Development Studio for Microcontrollers is an integrated tool suite that supports software development for Freescale's microcontrollers. Designers can further accelerate application development with the help of the award-winning Processor Expert tool in the CodeWarrior tool suite.

Freescale MQX RTOS and USB

Software Stack (complimentary**)

With the powerful integration of JE256/128 family, Freescale provides full production source code of Freescale MQX software:

- RTOS: Full priority-based, pre-emptive scheduler
- USB host/device
- MS-DOS file system (MFS)

Product Selector Guide

Part Number	Temp. Ranges	Package
MCF51JE256CML	-40°C to +85°C	104 MAPBGA
MCF51JE256CLL	-40°C to +85°C	100 LQFP
MCF51JE256CMB	-40°C to +85°C	81 MAPBGA
MCF51JE256CLK	-40°C to +85°C	80 LQFP
MCF51JE128CMB	-40°C to +85°C	81 MAPBGA
MCF51JE128CLK	-40°C to +85°C	80 LQFP
MCF51JE256VML	-40°C to +105°C	104 MAPBGA
MCF51JE256VLL	-40°C to +105°C	100 LQFP
MCF51JE256VMB	-40°C to +105°C	81 MAPBGA
MCF51JE256VLK	-40°C to +105°C	80 LQFP
MCF51JE128VMB	-40°C to +105°C	81 MAPBGA
MCF51JE128VLK	-40°C to +105°C	80 LQFP

Features	Benefits
CPU and System Configuration	
<ul style="list-style-type: none"> • 32-bit V1 ColdFire CPU Offering 46 MIPS at 50 MHz • 1.8V to 3.6V single supply 	<ul style="list-style-type: none"> • Offers high performance across the entire voltage range
On-Chip Memory	
<ul style="list-style-type: none"> • Up to 256 KB flash • Up to 32 KB SRAM • Mini FlexBus (external bus interface) 	<ul style="list-style-type: none"> • Allows the user to take full advantage of in-application re-programmability benefits in any environment • Security circuitry helps to prevent unauthorized RAM access • Glueless connection to external memory devices
Power Management	
<ul style="list-style-type: none"> • Low-power operation mode 	<ul style="list-style-type: none"> • Low-power Stop 2 current: 550 nA with 32K of SRAM enabled and active POR • 6 uS wake-up time from Stop 3 • 32 kHz oscillator for low-power time keeping • Rapid response to interrupts from the low-power sleep mode
Analog Related Peripherals	
<ul style="list-style-type: none"> • 12-bit ADC • 12-bit DAC • Programmable delay block • VREF (voltage reference) 	<ul style="list-style-type: none"> • High-resolution and high-accuracy ADC provides accurate signal acquisition • Digital-to-analog converter with clock gating optimized for low-power usage • PDB precisely triggers ADC and DAC blocks to complete sensor biasing and measurement (i.e. glucometry strips) • VREF accuracy is 33 ppm/°C from 0 °C to 50°C
Communication Peripherals	
<ul style="list-style-type: none"> • USB 2.0 controller • Dual asynchronous SCIs • Inter IC-BUS (I²C) • Dual synchronous SPI (1 x 64-bit FIFO SPI) 	<ul style="list-style-type: none"> • USB device/host/On-The-Go controller • On-chip transceiver and 3.3 volt regulator reduces system cost • Serial communication interface provides a simple, efficient method of data exchange between devices. Option to connect analog comparator to SCI for opto-isolation applications • I²C port enables increased system memory by using an additional I²C EEPROM • Two SPIs allow two separate dedicated devices, for example, one SPI dedicated to a ZigBee[®] transceiver and the other to MCUs or peripherals. SPI FIFO allows better performance to drive a graphic LCD.
Software and Tools	
<ul style="list-style-type: none"> • Background debug mode (BDM) for in-circuit debugging • Complimentary Freescale MQX software solutions, RTOS, USB, file system and strong third-party alliance network • Medical applications USB stack • Tower development system 	<ul style="list-style-type: none"> • Real-time trace and debug support • Value added tools and software, stacks and RTOS • Standardize with the "Continua Ready" personal health care device (PHDC) USB solution • The Freescale Tower System is a modular, reconfigurable demonstration and development platform

As other USB MCUs from Freescale, the JE256/128 devices are supported by USB stack with MSD, HID, CDC and PHDC classes. This USB stack can also be used for medical applications.

* Prices indicated are MSRP

** Subject to license agreement

Learn more: For current information about Freescale products and documentation, please visit freescale.com/MCF51JE.



Стандарт Электрон Связь

Мы молодая и активно развивающаяся компания в области поставок электронных компонентов. Мы поставляем электронные компоненты отечественного и импортного производства напрямую от производителей и с крупнейших складов мира.

Благодаря сотрудничеству с мировыми поставщиками мы осуществляем комплексные и плановые поставки широчайшего спектра электронных компонентов.

Собственная эффективная логистика и склад в обеспечивает надежную поставку продукции в точно указанные сроки по всей России.

Мы осуществляем техническую поддержку нашим клиентам и предпродажную проверку качества продукции. На все поставляемые продукты мы предоставляем гарантию .

Осуществляем поставки продукции под контролем ВП МО РФ на предприятия военно-промышленного комплекса России , а также работаем в рамках 275 ФЗ с открытием отдельных счетов в уполномоченном банке. Система менеджмента качества компании соответствует требованиям ГОСТ ISO 9001.

Минимальные сроки поставки, гибкие цены, неограниченный ассортимент и индивидуальный подход к клиентам являются основой для выстраивания долгосрочного и эффективного сотрудничества с предприятиями радиоэлектронной промышленности, предприятиями ВПК и научно-исследовательскими институтами России.

С нами вы становитесь еще успешнее!

Наши контакты:

Телефон: +7 812 627 14 35

Электронная почта: sales@st-electron.ru

Адрес: 198099, Санкт-Петербург,
Промышленная ул, дом № 19, литера Н,
помещение 100-Н Офис 331