

UG257: EFM32 Pearl Gecko PG12 Starter Kit User's Guide

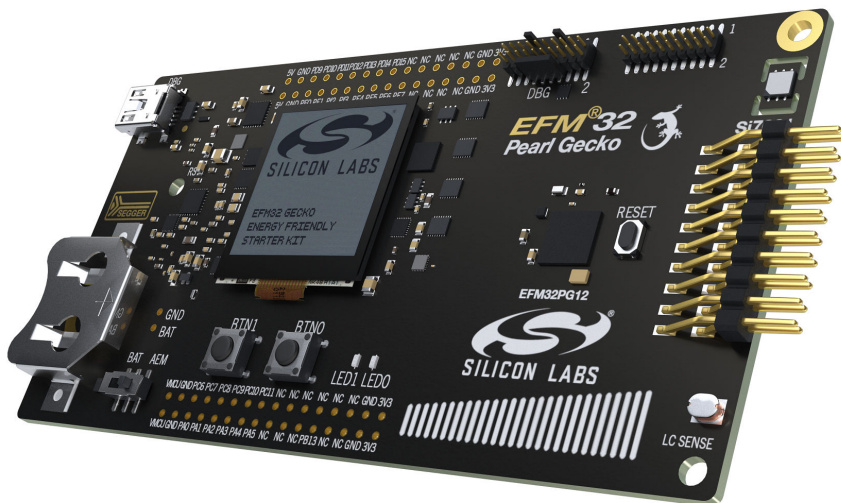

The SLSTK3402A Starter Kit is an excellent starting point to get familiar with the EFM32™ Pearl Gecko PG12 Microcontroller.

The Starter Kit contains sensors and peripherals demonstrating some of the Pearl Gecko PG12's many capabilities. The kit provides all necessary tools for developing an EFM32 Pearl Gecko PG12 application.



TARGET DEVICE

- EFM32 Pearl Gecko PG12 Microcontroller (EFM32PG12B500F1024GL125)
- CPU: 32-bit ARM® Cortex-M4® with FPU
- Memory: 1024 kB flash and 256 kB RAM

KIT FEATURES

- USB connectivity
- Advanced Energy Monitor
- SEGGER J-Link on-board debugger
- Debug Multiplexer supporting external hardware as well as on-board MCU
- Silicon Labs' Si7021 Relative Humidity and Temperature sensor
- Ultra low power 128x128 pixel Memory LCD
- User LEDs / Pushbuttons
- Inductive LC sensor
- Capacitive touch slider
- 20-pin 2.54 mm header for expansion boards
- Breakout pads for direct access to I/O pins
- Power sources include USB and CR2032 coin cell battery.

SOFTWARE SUPPORT

- Simplicity Studio™
- Energy Profiler

1. Introduction

1.1 Description

The SLSTK3402A is an excellent starting point to get familiar with the EFM32 Pearl Gecko PG12 Microcontrollers. The kit contains sensors and peripherals demonstrating some of the MCU's many capabilities. The kit can also serve as a starting point for application development.

In addition to supporting application development on the starter kit itself, the board is also a fully featured debugger and energy monitoring tool that can be used with external applications.

1.2 Features

- EFM32PG12B500F1024GL125 MCU with 1024 kB Flash and 256 kB RAM.
- Advanced Energy Monitoring system for precise current and voltage tracking.
- Integrated Segger J-Link USB debugger/emulator with the possibility to debug external Silicon Labs devices.
- 20 pin expansion header.
- Breakout pads for easy access to I/O pins.
- Power sources including USB and CR2032 battery.
- Silicon Labs Si7021 Relative Humidity and Temperature Sensor
- Ultra low power 128x128 pixel Memory-LCD
- 2 push buttons and 2 LEDs connected to EFM32 for user interaction
- LC tank circuit for inductive sensing
- 4-segment capacitive touch slider
- Crystals for LFXO and HFXO: 32.768 kHz and 40.000 MHz.

1.3 Getting Started

Hardware

To set up the hardware for the SLSTK3402A kit:

1. Provide power to the board by connecting the DBG USB connector to the PC using the provided mini-USB cable.
2. Ensure that the power selector switch is in the AEM position.

Software

Detailed instructions for how to get started with your new SLSTK3402A can be found on the Silicon Labs web pages:

<http://www.silabs.com/simplicity>

2. Kit Block Diagram

An overview of the EFM32 Pearl Gecko PG12 Starter Kit is shown in the figure below.

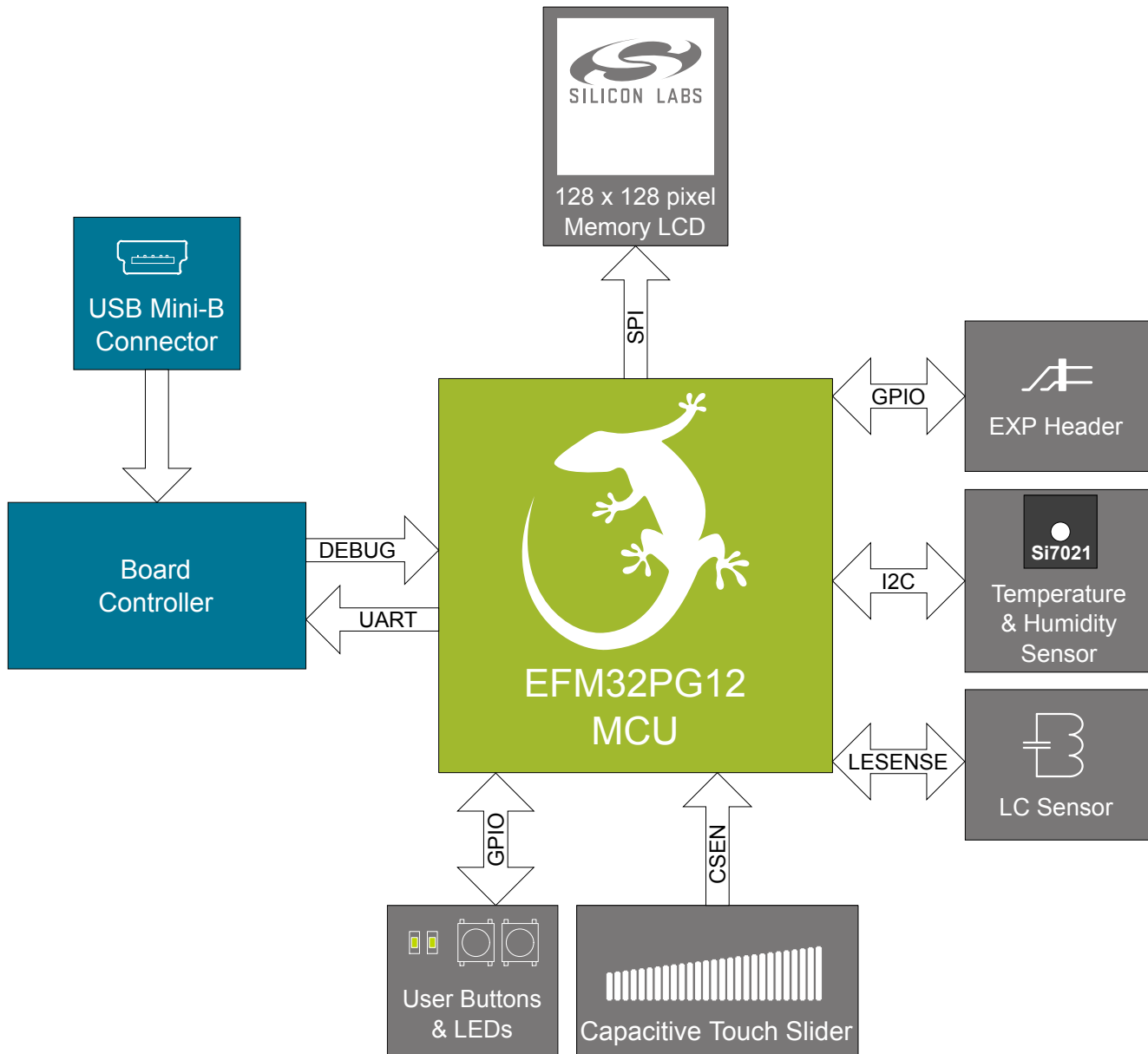

Figure 2.1. Kit Block Diagram

3. Kit Hardware Layout

The layout of the EFM32 Pearl Gecko PG12 Starter Kit is shown below.

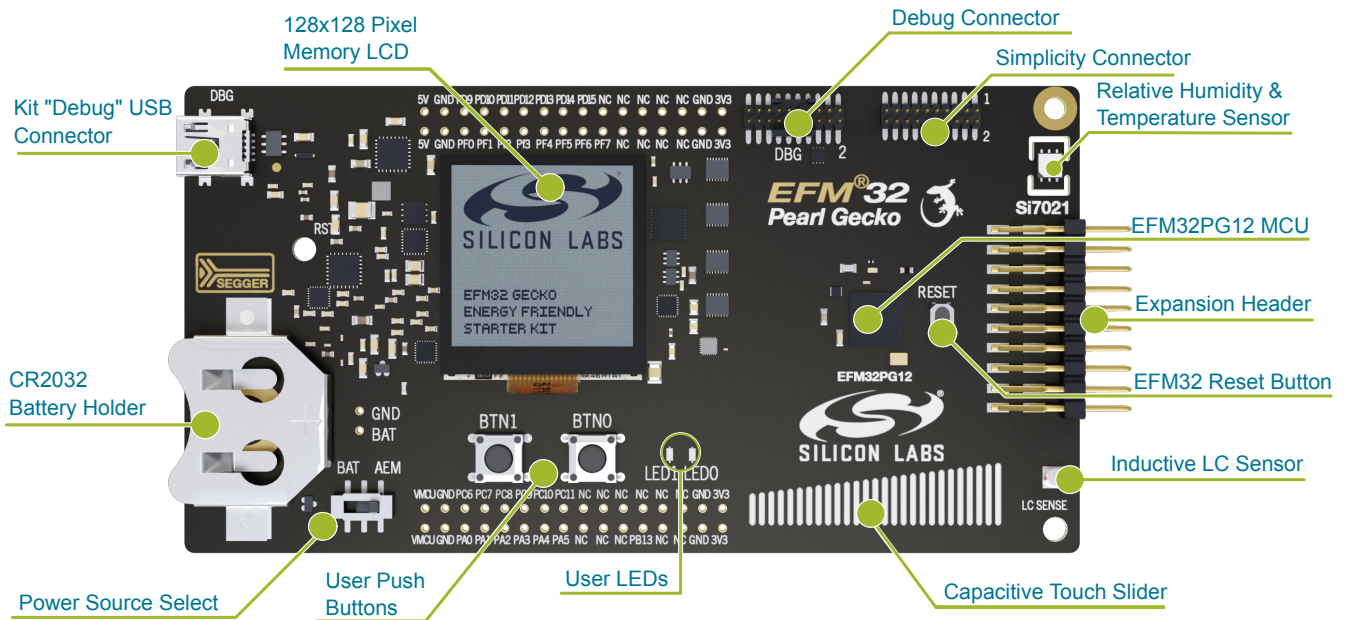

Figure 3.1. SLSTK3402A Hardware Layout

4. Connectors

4.1 Breakout Pads

Most of the EFM32's GPIO pins are available on two pin header rows at the top and bottom edges of the board. These have a standard 2.54 mm pitch, and pin headers can be soldered in if required. In addition to the I/O pins, connections to the different power rails and ground are also provided. Note that some of the pins are used for kit peripherals or features, and may not be available for a custom application without trade-offs.

The figure below shows the pinout of these "breakout pads", as well as the pinout of the "Expansion Header" situated on the right-hand side of the board. The expansion header is further explained in the next section. The breakout pad connections are also printed in silk screen next to each pin for easy reference.

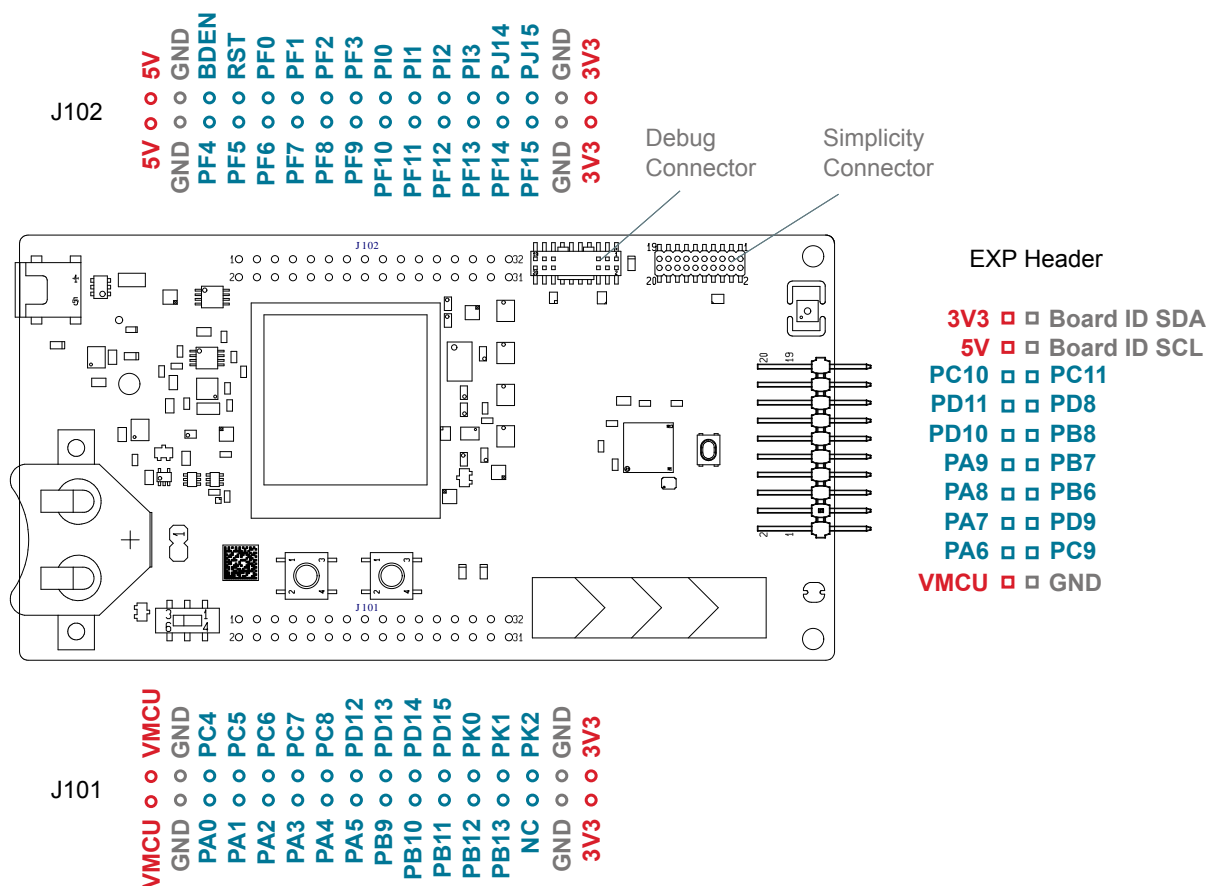

Figure 4.1. Breakout Pads and Expansion Header

The table below shows the connections of each pin of the breakout pads. They also show which kit peripherals or features are connected to the different pins.

Table 4.1. Bottom Row (J101) Pinout

| Pin | EFM32 I/O pin | Shared feature | Pin | EFM32 I/O pin | Shared feature |
|-----|---------------|----------------------|-----|---------------|----------------------|
| 1 | VMCU | EFM32 voltage domain | 2 | VMCU | EFM32 voltage domain |
| 3 | GND | Ground | 4 | GND | Ground |
| 5 | PA0 | VCOM_TX | 6 | PC4 | |
| 7 | PA1 | VCOM_RX | 8 | PC5 | |
| 9 | PA2 | VCOM_CTS | 10 | PC6 | DISP_SI |

| Pin | EFM32 I/O pin | Shared feature | Pin | EFM32 I/O pin | Shared feature |
|-----|---------------|-------------------------|-----|---------------|-------------------------|
| 11 | PA3 | VCOM_RTS | 12 | PC7 | |
| 13 | PA4 | LES_LC_SENSE | 14 | PC8 | DISP_SCLK |
| 15 | PA5 | VCOM_ENABLE | 16 | PD12 | DAC_LC_EXCITE |
| 17 | PB9 | | 18 | PD13 | DISP_COM |
| 19 | PB10 | SENSOR_ENABLE | 20 | PD14 | DISP_CS |
| 21 | PB11 | | 22 | PD15 | DISP_ENABLE |
| 23 | PB12 | | 24 | PK0 | |
| 25 | PB13 | | 26 | PK1 | |
| 27 | - | Not connected | 28 | PK2 | |
| 29 | GND | Ground | 30 | GND | Ground |
| 31 | 3V3 | Board controller supply | 32 | 3V3 | Board controller supply |

Table 4.2. Top Row (J102) Pinout

| Pin | EFM32 I/O pin | Shared feature | Pin | EFM32 I/O pin | Shared feature |
|-----|---------------|-------------------------|-----|---------------|-------------------------|
| 1 | 5V | Board USB voltage | 2 | 5V | Board USB voltage |
| 3 | GND | Ground | 4 | GND | Ground |
| 5 | PF4 | UIF_LED0 | 6 | BDEN | BOD_ENABLE |
| 7 | PF5 | UIF_LED1 | 8 | RST | DEBUG_RESETn |
| 9 | PF6 | UIF_BUTTON0 | 10 | PF0 | DEBUG_TCK_SWCLK |
| 11 | PF7 | UIF_BUTTON1 | 12 | PF1 | DEBUG_TMS_SWDIO |
| 13 | PF8 | DEBUG_TRACECLK | 14 | PF2 | DEBUG_TDO_SWO |
| 15 | PF9 | DEBUG_TRACED0 | 16 | PF3 | DEBUG_TDI |
| 17 | PF10 | DEBUG_TRACED1 | 18 | PI0 | |
| 19 | PF11 | DEBUG_TRACED2 | 20 | PI1 | |
| 21 | PF12 | DEBUG_TRACED3 | 22 | PI2 | |
| 23 | PF13 | | 24 | PI3 | |
| 25 | PF14 | | 26 | PJ14 | |
| 27 | PF15 | | 28 | PJ15 | |
| 29 | GND | Ground | 30 | GND | Ground |
| 31 | 3V3 | Board controller supply | 32 | 3V3 | Board controller supply |

4.2 Expansion Header

On the right hand side of the board an angled 20 pin expansion header is provided to allow connection of peripherals or plugin boards. The connector contains a number of I/O pins that can be used with most of the EFM32 Pearl Gecko PG12's features. Additionally, the VMCU, 3V3 and 5V power rails are also exported.

The connector follows a standard which ensures that commonly used peripherals such as an SPI, a UART and an I2C bus are available on fixed locations in the connector. The rest of the pins are used for general purpose I/O. This allows the definition of expansion boards that can plug into a number of different Silicon Labs starter kits.

The figure below shows the pin assignment of the expansion header for the EFM32 Pearl Gecko PG12 Starter Kit. Because of limitations in the number of available GPIO pins, some of the expansion header pins are shared with kit features.

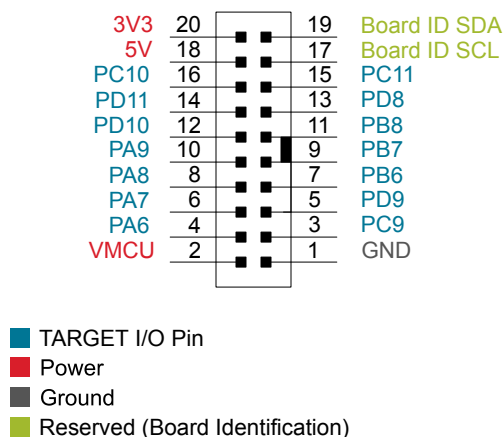

Figure 4.2. Expansion Header

Table 4.3. EXP Header Pinout

| Pin | Connection | EXP Header function | Shared feature | Peripheral mapping |
|-----|--------------|--|----------------|--------------------|
| 20 | 3V3 | Board controller supply | | |
| 18 | 5V | Board USB voltage | | |
| 16 | PC10 | I2C_SDA | SENSOR_I2C_SDA | I2C0_SDA #15 |
| 14 | PD11 | UART_RX | | LEU0_RX #18 |
| 12 | PD10 | UART_TX | | LEU0_TX #18 |
| 10 | PA9 | SPI_CS | | USART2_CS #1 |
| 8 | PA8 | SPI_SCLK | | USART2_CLK #1 |
| 6 | PA7 | SPI_MISO | | USART2_RX #1 |
| 4 | PA6 | SPI_MOSI | | USART2_TX #1 |
| 2 | VMCU | EFM32 voltage domain, included in AEM measurements. | | |
| 19 | BOARD_ID_SDA | Connected to Board Controller for identification of add-on boards. | | |
| 17 | BOARD_ID_SCL | Connected to Board Controller for identification of add-on boards. | | |
| 15 | PC11 | I2C_SCL | SENSOR_I2C_SCL | I2C0_SCL #15 |
| 13 | PD8 | GPIO | | USART3_CS #29 |

| Pin | Connection | EXP Header function | Shared feature | Peripheral mapping |
|-----|------------|---------------------|----------------|--------------------|
| 11 | PB8 | GPIO | | USART3_CLK #10 |
| 9 | PB7 | GPIO | I2C1_SCL #6 | USART3_RX #10 |
| 7 | PB6 | GPIO | I2C1_SDA #6 | USART3_TX #10 |
| 5 | PD9 | GPIO | | |
| 3 | PC9 | GPIO | | |
| 1 | GND | Ground | | |

4.3 Debug Connector (DBG)

The Debug Connector serves a dual purpose. Based on the "debug mode", which can be set up using Simplicity Studio. In the "Debug IN" mode this connector allows an external debug emulator to be used with the on-board EFM32. In the "Debug OUT" mode this connector allows the kit to be used as a debugger towards an external target. In the "Debug MCU" (default) mode this connector is isolated from the debug interface of both the Board Controller and the on-board target device.

Because this connector is automatically switched to support the different operating modes, it is only available when the Board Controller is powered (J-Link USB cable connected). If debug access to the target device is required when the Board Controller is unpowered, this should be done by connecting directly to the appropriate breakout pins.

The pinout of the connector follows that of the standard ARM Cortex Debug+ETM 19-pin connector. The pinout is described in detail below. Note that even though the connector has support for both JTAG and ETM Trace in addition to Serial Wire Debug, it does not necessarily mean that the kit or the on-board target device supports this.

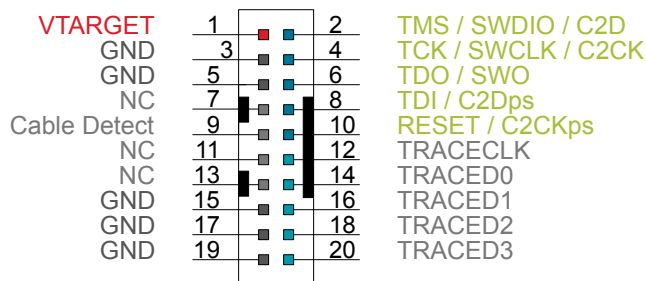

Figure 4.3. Debug Connector

Note that the pin-out matches the pin-out of an ARM Cortex Debug+ETM connector, but these are not fully compatible as pin 7 is physically removed from the Cortex Debug+ETM connector. Some cables have a small plug that prevent them from being used when this pin is present. If this is the case, remove the plug, or use a standard 2x10 1.27 mm straight cable instead.

Table 4.4. Debug Connector Pin Descriptions

| Pin number(s) | Function | Note |
|------------------|--------------------|--|
| 1 | VTARGET | Target reference voltage. Used for shifting logical signal levels between target and debugger. |
| 2 | TMS / SDWIO / C2D | JTAG test mode select, Serial Wire data or C2 data |
| 4 | TCK / SWCLK / C2CK | JTAG test clock, Serial Wire clock or C2 clock |
| 6 | TDO/SWO | JTAG test data out or Serial Wire Output |
| 8 | TDI / C2Dps | JTAG test data in, or C2D "pin sharing" function |
| 10 | RESET / C2CKps | Target device reset, or C2CK "pin sharing" function |
| 12 | TRACECLK | ETM Trace Clock |
| 14 | TRACED0 | ETM Trace Data 0 |
| 16 | TRACED1 | ETM Trace Data 1 |
| 18 | TRACED2 | ETM Trace Data 2 |
| 20 | TRACED3 | ETM Trace Data 3 |
| 9 | Cable detect | Connect to ground |
| 11, 13 | NC | Not connected |
| 3, 5, 15, 17, 19 | GND | |

4.4 Simplicity Connector

The Simplicity Connector featured on the Starter Kit enables advanced debugging features such as the AEM and the Virtual COM port to be used towards an external target. The pinout is illustrated in the figure below.

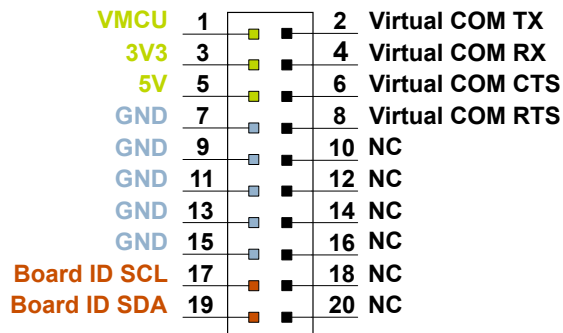

Figure 4.4. Simplicity Connector

Note: Current drawn from the VMCU voltage pin is included in the AEM measurements, while the 3V3 and 5V voltage pins are not. To monitor the current consumption of an external target with the AEM, put the on-board MCU in its lowest energy mode to minimize its impact on the measurements.

Table 4.5. Simplicity Connector Pin Descriptions

| Pin number(s) | Function | Description |
|------------------------|------------|--|
| 1 | VMCU | 3.3 V power rail, monitored by the AEM |
| 3 | 3V3 | 3.3 V power rail |
| 5 | 5V | 5 V power rail |
| 2 | VCOM_TX | Virtual COM Tx |
| 4 | VCOM_RX | Virtual COM Rx |
| 6 | VCOM_CTS | Virtual COM CTS |
| 8 | VCOM_RTS | Virtual COM RTS |
| 17 | EXT_ID_SCL | Board ID SCL |
| 19 | EXT_ID_SDA | Board ID SDA |
| 10, 12, 14, 16, 18, 20 | NC | Not connected |
| 7, 9, 11, 13, 15 | GND | Ground |

5. Power Supply and Reset

5.1 MCU Power Selection

The EFM32 on the Starter Kit can be powered by one of these sources:

- The debug USB cable; or
- a 3 V coin cell battery.

The power source for the MCU is selected with the slide switch in the lower left corner of the Starter Kit. [Figure 5.1 Power Switch on page 10](#) shows how the different power sources can be selected with the slide switch.

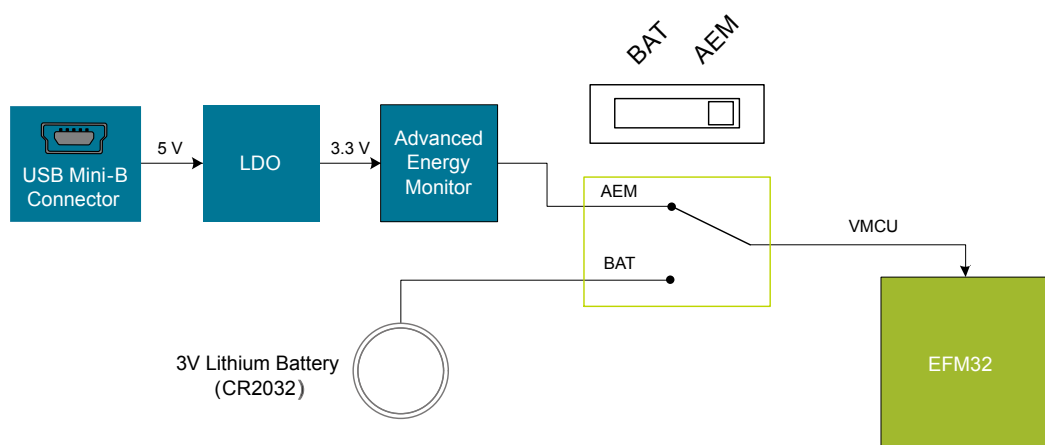

Figure 5.1. Power Switch

With the switch in the **AEM** position, a low noise 3.3 V LDO on the Starter Kit is used to power the EFM32. This LDO is again powered from the debug USB cable. The Advanced Energy Monitor is now connected in series, allowing accurate high speed current measurements and energy debugging/profiling.

With the switch in the **BAT** position, a 20 mm coin cell battery in the CR2032 socket can be used to power the device. With the switch in this position no current measurements are active. This is the recommended switch position when powering the MCU with an external power source.

Note: The Advanced Energy Monitor can only measure the current consumption of the EFM32 when the power selection switch is in the **AEM** position.

5.2 Board Controller Power

The board controller is responsible for important features such as the debugger and the Advanced Energy Monitor, and is powered exclusively through the USB port in the top left corner of the board. This part of the kit resides on a separate power domain, so a different power source can be selected for the target device while retaining debugging functionality. This power domain is also isolated to prevent current leakage from the target power domain when power to the Board Controller is removed.

The board controller power domain is exclusively supplied by the J-Link USB cable, and is not influenced by the position of the power switch.

The kit has been carefully designed to keep the board controller and the target power domains isolated from each other as one of them powers down. This ensures that the target EFM32 device will continue to operate in the **USB** and **BAT** modes.

5.3 EFM32 Reset

The EFM32 MCU can be reset by a few different sources:

- A user pressing the RESET button.
- The on-board debugger pulling the #RESET pin low.
- An external debugger pulling the #RESET pin low.

In addition to the reset sources mentioned above, the Board Controller will also issue a reset to the EFM32 when booting up. This means that removing power to the Board Controller (plugging out the J-Link USB cable) will not generate a reset, but plugging the cable back in will, as the Board Controller boots up.

6. Peripherals

The starter kit has a set of peripherals that showcase some of the features of the EFM32.

Be aware that most EFM32 I/O routed to peripherals are also routed to the breakout pads. This must be taken into consideration when using the breakout pads for your application.

6.1 Push Buttons and LEDs

The kit has two user push buttons marked BTN0 and BTN1. They are connected directly to the EFM32, and are debounced by RC filters with a time constant of 1 ms. The buttons are connected to pins PF6 and PF7.

The kit also features two yellow LEDs marked LED0 and LED1, that are controlled by GPIO pins on the EFM32. The LEDs are connected to pins PF4 and PF5 in an active-high configuration.

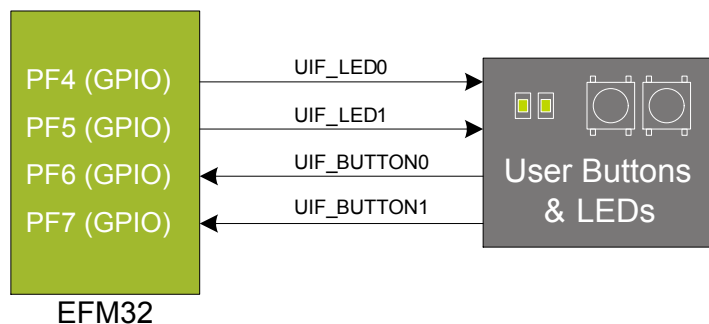

Figure 6.1. Buttons and LEDs

6.2 Memory LCD-TFT Display

A 1.28-inch SHARP Memory LCD-TFT has been added to the board to enable interactive applications to be developed. The display has a high resolution of 128 by 128 pixels, and consumes very little power. It is a reflective monochrome display, so each pixel can only be light or dark, and no backlight is needed in normal daylight conditions. Data sent to the display is stored in the pixels on the glass, which means no continuous refreshing is required to maintain a static image.

The display interface consists of an SPI-compatible serial interface and some extra control signals. Pixels are not individually addressable, instead data is sent to the display one line (128 bits) at a time.

The Memory LCD-TFT display is shared with the kit Board Controller, allowing the Board Controller application to display useful information when the user application is not using the display. The user application always controls ownership of the display with the DISP_ENABLE line:

- 0: The Board Controller has control of the display
- 1: The user application (EFM32) has control of the display

Power to the display is sourced from the target application power domain when the EFM32 controls the display, and from the Board Controller's power domain when the DISP_ENABLE line is low. Data is clocked in on DISP_SI when DISP_CS is high, and the clock is sent on DISP_SCLK. The maximum supported clock speed is 1.1 MHz.

DISP_COM is the "COM Inversion" line. It must be pulsed periodically to prevent static build-up in the display itself. Please refer to the display application information for details on driving the display:

<http://www.sharpmemorylcd.com/1-28-inch-memory-lcd.html>

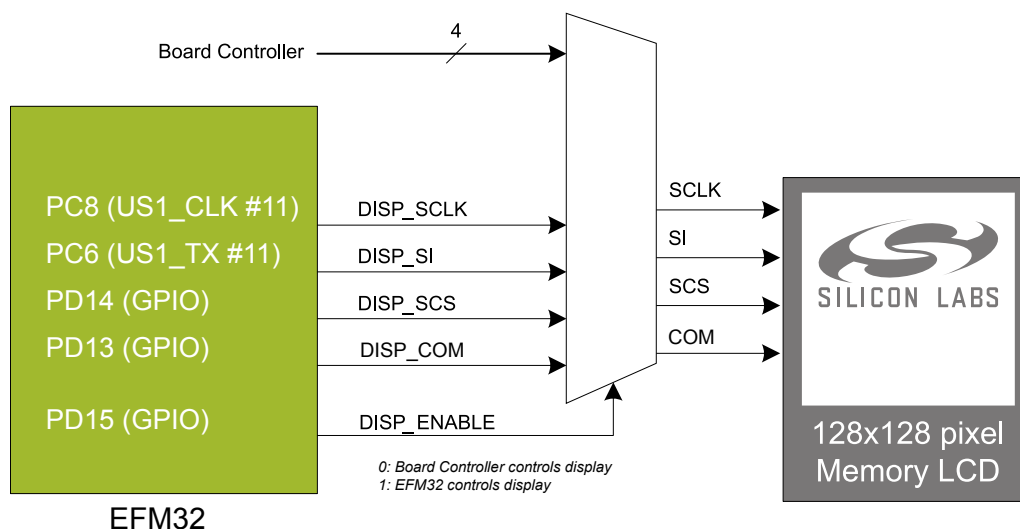

Figure 6.2. 128x128 pixel Memory LCD

6.3 Capacitive Touch Slider

A touch slider utilizing the capacitive touch capability of the EFM32 is available. It is located on the lower right side of the board, beneath the EFM32. It consists of four interleaved pads which are connected to PC0, PC1, PC2 and PC3.

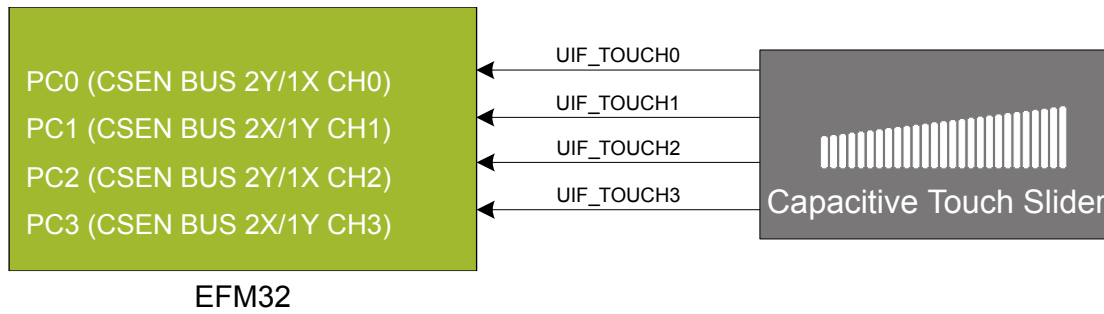

Figure 6.3. Touch Slider

The capacitive touch pads work by sensing changes in the capacitance of the pads when touched by a human finger. Sensing the changes in capacitance is done by setting up the EFM32's analog capacitive sense peripheral (CSEN).

6.4 Si7021 Relative Humidity and Temperature Sensor

The Si7021 I²C relative humidity and temperature sensor is a monolithic CMOS IC integrating humidity and temperature sensor elements, an analog-to-digital converter, signal processing, calibration data, and an I²C Interface. The patented use of industry-standard, low-K polymeric dielectrics for sensing humidity enables the construction of low-power, monolithic CMOS Sensor ICs with low drift and hysteresis, and excellent long term stability.

The humidity and temperature sensors are factory-calibrated and the calibration data is stored in the on-chip non-volatile memory. This ensures that the sensors are fully interchangeable, with no recalibration or software changes required.

The Si7021 is available in a 3x3 mm DFN package and is reflow solderable. It can be used as a hardware- and software-compatible drop-in upgrade for existing RH/ temperature sensors in 3x3 mm DFN-6 packages, featuring precision sensing over a wider range and lower power consumption. The optional factory-installed cover offers a low profile, convenient means of protecting the sensor during assembly (e.g., reflow soldering) and throughout the life of the product, excluding liquids (hydrophobic/oleophobic) and particulates.

The Si7021 offers an accurate, low-power, factory-calibrated digital solution ideal for measuring humidity, dew-point, and temperature, in applications ranging from HVAC/R and asset tracking to industrial and consumer platforms.

The I²C bus used for the Si7021 is shared with the Expansion Header. The temperature sensor is normally isolated from the I²C line. To use the sensor, SENSOR_ENABLE (PB10) must be set high. When enabled, the sensor's current consumption is included in the AEM measurements.

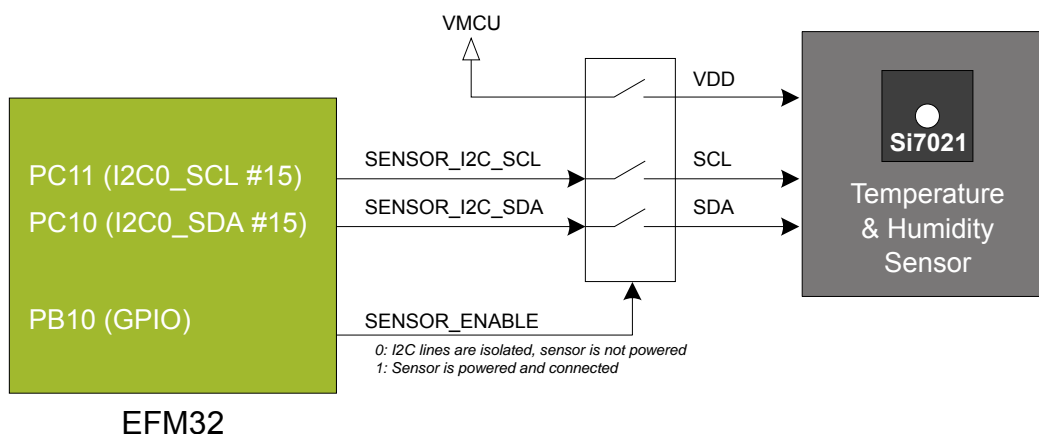

Figure 6.4. Si7021 Relative Humidity and Temperature Sensor

Please refer to the Silicon Labs web pages for more information: <http://www.silabs.com/humidity-sensors>

6.5 LC Sensor

In the bottom right corner of the board there is an inductive-capacitive sensor for demonstrating the low energy sensor interface (LESENSE). The LESENSE peripheral uses the voltage digital-to-analog converter (VDAC) to set up an oscillating current through the inductor, and then uses the analog comparator (ACMP) to measure the oscillation decay time. The oscillation decay time will be affected by the presence of metal objects within a few millimeters of the inductor. For more information please refer to application note AN0029 Low Energy Sensor Interface - Inductive Sense

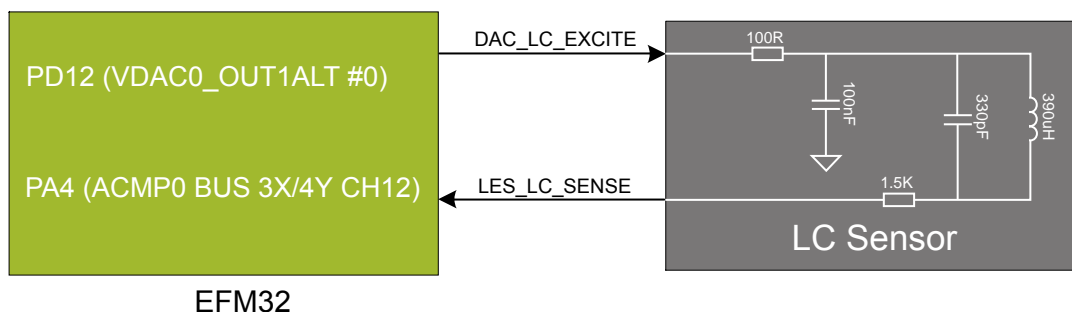

Figure 6.5. LC Metal Sensor

6.6 Virtual COM Port

An asynchronous serial connection to the board controller is provided for application data transfer between a host PC and the target EFM32. This eliminates the need for an external serial port adapter.

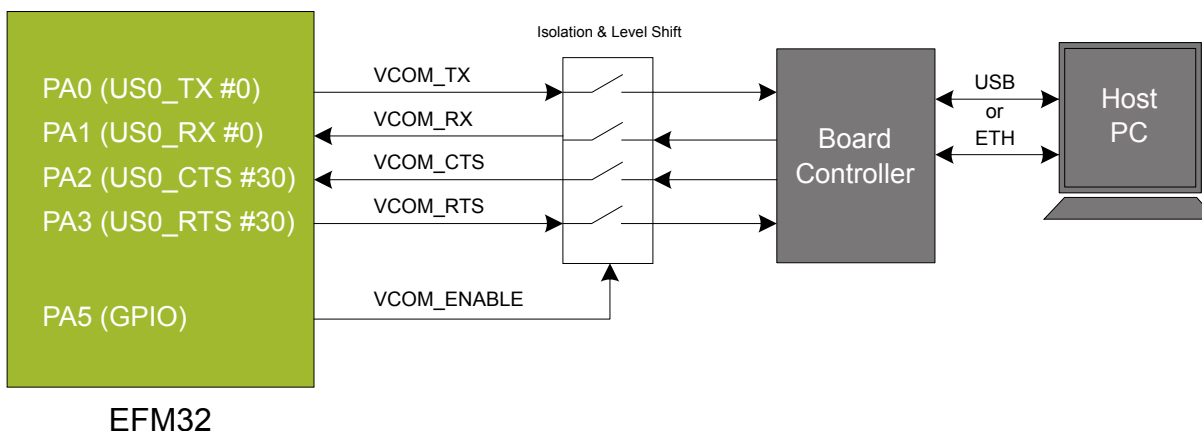

Figure 6.6. Virtual COM Port Interface

The Virtual COM port consists of a physical UART between the target device and the board controller, and a logical function in the board controller that makes the serial port available to the host PC over USB or Ethernet. The UART interface consists of four pins and an enable signal.

Table 6.1. Virtual COM Port Interface Pins

| Signal | Description |
|-------------|---|
| VCOM_TX | Transmit data from the EFM32 to the board controller |
| VCOM_RX | Receive data from the board controller to the EFM32 |
| VCOM_CTS | Clear to Send hardware flow control input, asserted by the board controller when it is ready to receive more data |
| VCOM_RTS | Request to Send hardware flow control output, asserted by the EFM32 when it is ready to receive more data |
| VCOM_ENABLE | Enables the VCOM interface, allowing data to pass through to the board controller. |

Note: The VCOM port is only available when the board controller is powered, which requires the J-Link USB cable to be inserted.

7. Advanced Energy Monitor

7.1 Usage

The AEM (Advanced Energy Monitor) data is collected by the board controller and can be displayed by the Energy Profiler, available through Simplicity Studio. By using the Energy Profiler, current consumption and voltage can be measured and linked to the actual code running on the EFM32 in realtime.

7.2 Theory of Operation

In order to be able to accurately measure current ranging from 0.1 μA to 50 mA (114 dB dynamic range), a current sense amplifier is utilized together with a dual gain stage. The current sense amplifier measures the voltage drop over a small series resistor, and the gain stage further amplifies this voltage with two different gain settings to obtain two current ranges. The transition between these two ranges occurs around 250 μA . Digital filtering and averaging is done within the Board Controller before the samples are exported to the Energy Profiler application.

During startup of the kit, an automatic calibration of the AEM is performed. This calibration compensates for the offset error in the sense amplifiers.

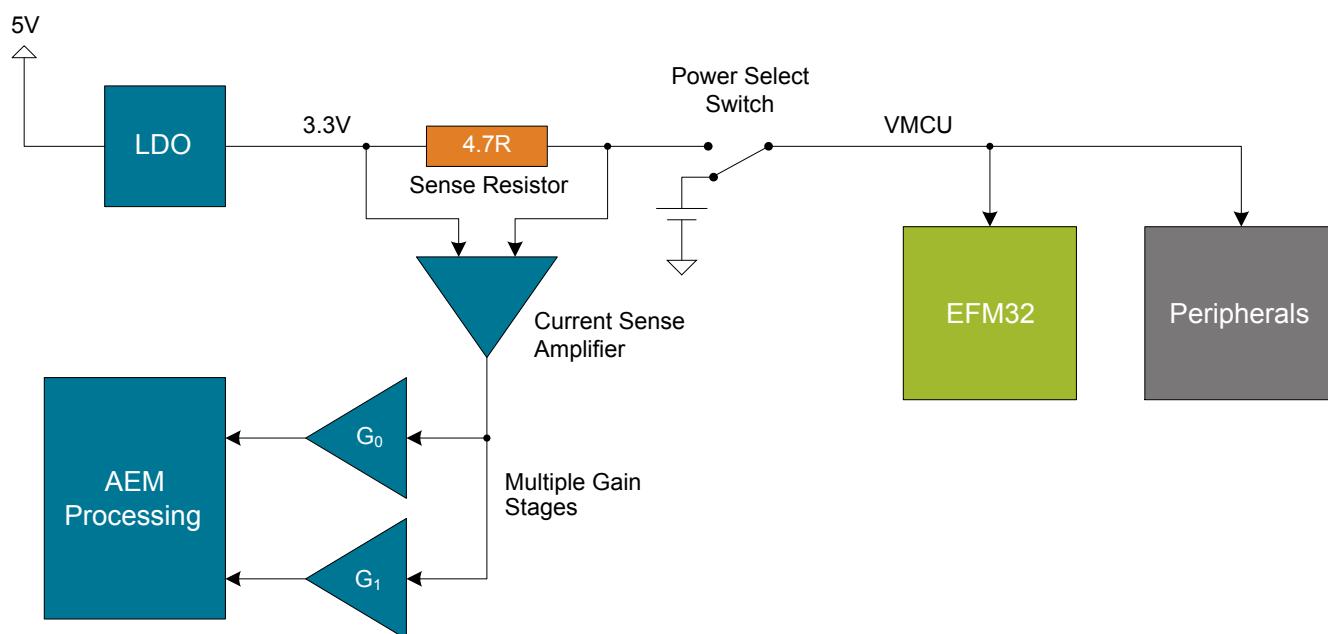

Figure 7.1. Advanced Energy Monitor

7.3 Accuracy and Performance

The Advanced Energy Monitor is capable of measuring currents in the range of 0.1 μA to 50 mA. For currents above 250 μA , the AEM is accurate within 0.1 mA. When measuring currents below 250 μA , the accuracy increases to 1 μA . Even though the absolute accuracy is 1 μA in the sub 250 μA range, the AEM is able to detect changes in the current consumption as small as 100 nA. The AEM produces 6250 current samples per second.

8. On-Board Debugger

The SLSTK3402A contains an integrated debugger, which can be used to download code and debug the EFM32. In addition to programming the EFM32 on the kit, the debugger can also be used to program and debug external Silicon Labs EFM32, EFM8, EZR32 and EFR32 devices.

The debugger supports three different debug interfaces used with Silicon Labs devices:

- Serial Wire Debug, is used with all EFM32, EFR32 and EZR32 devices
- JTAG, which can be used with some newer EFR32 and EFM32 devices
- C2 Debug, which is used with EFM8 devices

In order for debugging to work properly, make sure you have the appropriate debug interface selected that works with your device. The debug connector on the board supports all three of these modes.

8.1 Debug Modes

Programming external devices is done by connecting to a target board through the provided Debug IN/OUT Connector, and by setting the debug mode to [Out]. The same connector can also be used to connect an external debugger to the EFM32 MCU on the kit, by setting the debug mode to [In].

Selecting the active debug mode is done with a drop-down menu in the Kit Manager tool in Simplicity Studio.

Debug MCU: In this mode the on-board debugger is connected to the EFM32 on the SLSTK3402A.

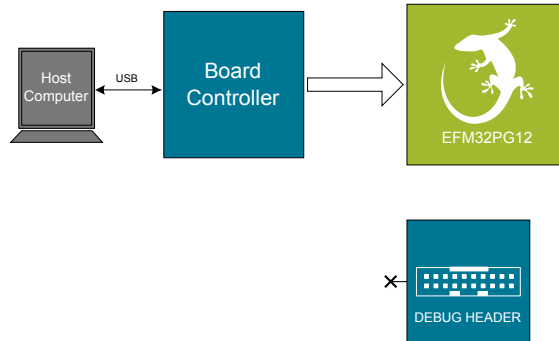

Figure 8.1. Debug MCU

Debug OUT: In this mode, the on-board debugger can be used to debug a supported Silicon Labs device mounted on a custom board.

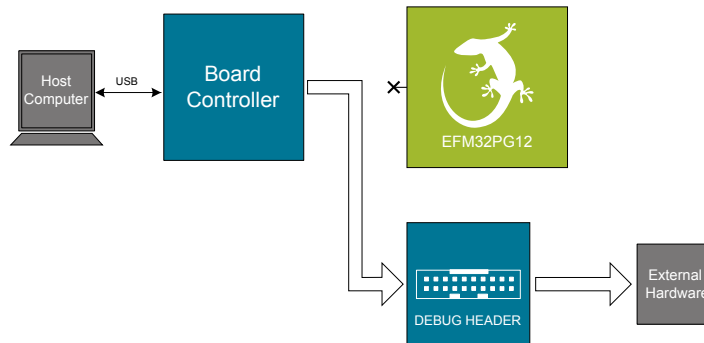

Figure 8.2. Debug OUT

Debug IN: In this mode, the on-board debugger is disconnected, and an external debugger can be connected to debug the EFM32 on the SLSTK3402A.

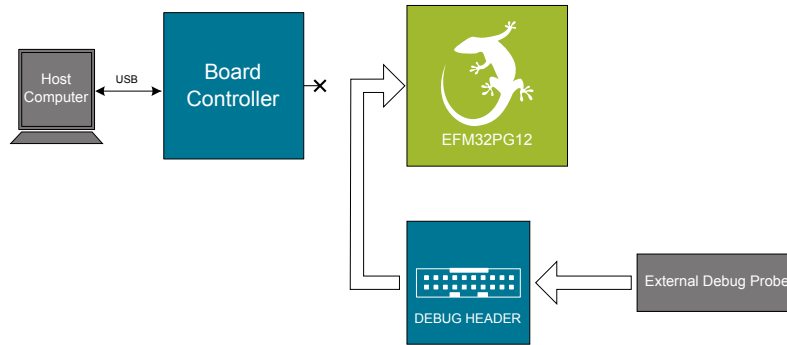

Figure 8.3. Debug IN

Note: For "Debug IN" to work, the board controller on the kit must be powered through the USB connector.

8.2 Debugging During Battery Operation

When the EFM32 is powered by battery and the J-Link USB is still connected, the on-board debug functionality is available. If the USB power is disconnected, the Debug In mode will stop working.

If debug access is required when the target is running on another energy source, such as a battery, and the board controller is powered down, the user should make direct connections to the GPIO used for debugging. This can be done by connecting to the appropriate pins of the breakout pads. Some Silicon Labs kits provide a dedicated pin header for this purpose.

9. Kit Configuration and Upgrades

The kit configuration dialog in Simplicity Studio allows you to change the J-Link adapter debug mode, upgrade its firmware and change other configuration settings.

In the main window of the Simplicity Studio's Launcher perspective, the debug mode and firmware version of the selected J-Link adapter is shown. Click the 'Change' link next to any of them to open the kit configuration dialog.

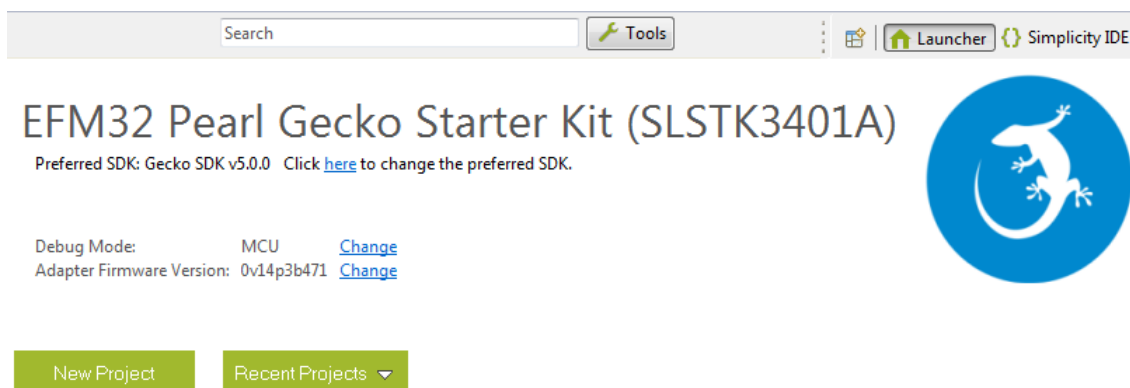

Figure 9.1. Launcher Perspective Kit Info

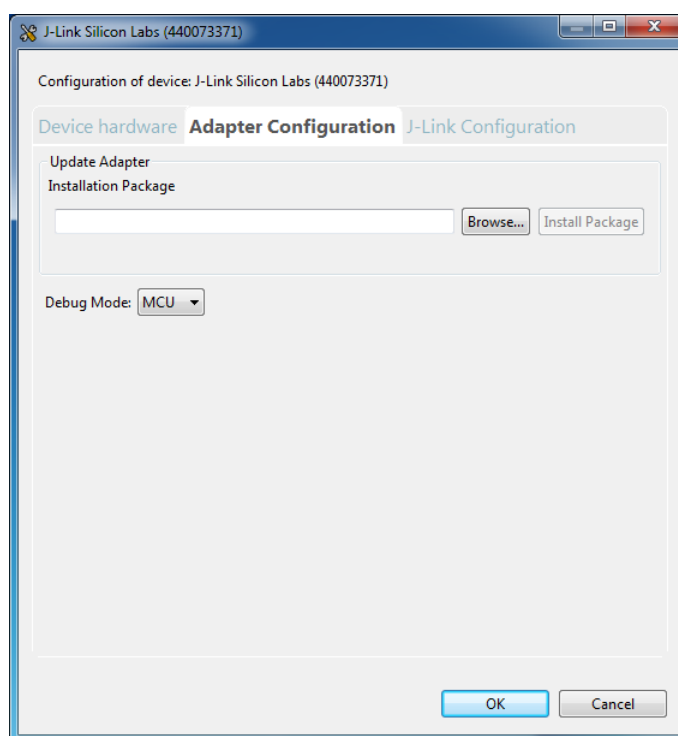

Figure 9.2. Kit Configuration Dialog

9.1 Firmware Upgrades

Upgrading the kit firmware is done through Simplicity Studio. Simplicity Studio will automatically check for new updates on startup.

You can also use the kit configuration dialog for manual upgrades. Click the **[Browse]** button in the **[Update Adapter]** section to select the correct file ending in ".emz". Then, click the **[Install Package]** button.

10. Schematics, Assembly Drawings and BOM

The schematics, assembly drawings and bill of materials (BOM) for the hardware included in the EFM32 Pearl Gecko PG12 Starter Kit are available through Simplicity Studio when the kit documentation package has been installed.

11. Kit Revision History and Errata

11.1 Revision History

The kit revision can be found printed on the box label of the kit, as outlined in the figure below.

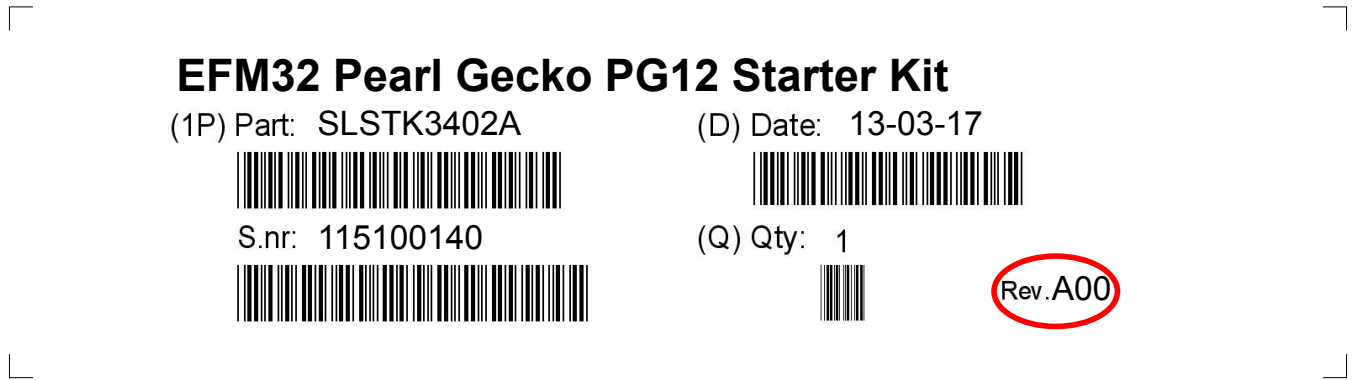

Figure 11.1. Revision Info

Table 11.1. Kit Revision History

| Kit Revision | Released | Description |
|--------------|------------|-----------------------|
| A00 | 2017-01-03 | Initial Kit Revision. |

11.2 Errata

There are no known errata at present.

12. Document Revision History

Revision 1.00

2017-01-13

Initial document version.

Table of Contents

| | |
|---|-----------|
| 1. Introduction | 1 |
| 1.1 Description | 1 |
| 1.2 Features. | 1 |
| 1.3 Getting Started | 1 |
| 2. Kit Block Diagram | 2 |
| 3. Kit Hardware Layout | 3 |
| 4. Connectors | 4 |
| 4.1 Breakout Pads | 4 |
| 4.2 Expansion Header | 6 |
| 4.3 Debug Connector (DBG) | 8 |
| 4.4 Simplicity Connector. | 9 |
| 5. Power Supply and Reset | 10 |
| 5.1 MCU Power Selection | 10 |
| 5.2 Board Controller Power. | 10 |
| 5.3 EFM32 Reset | 11 |
| 6. Peripherals | 12 |
| 6.1 Push Buttons and LEDs | 12 |
| 6.2 Memory LCD-TFT Display. | 13 |
| 6.3 Capacitive Touch Slider | 14 |
| 6.4 Si7021 Relative Humidity and Temperature Sensor | 15 |
| 6.5 LC Sensor | 16 |
| 6.6 Virtual COM Port | 17 |
| 7. Advanced Energy Monitor | 18 |
| 7.1 Usage | 18 |
| 7.2 Theory of Operation | 18 |
| 7.3 Accuracy and Performance | 18 |
| 8. On-Board Debugger. | 19 |
| 8.1 Debug Modes | 20 |
| 8.2 Debugging During Battery Operation | 21 |
| 9. Kit Configuration and Upgrades | 22 |
| 9.1 Firmware Upgrades | 22 |
| 10. Schematics, Assembly Drawings and BOM | 23 |
| 11. Kit Revision History and Errata | 24 |
| 11.1 Revision History. | 24 |

| | |
|--|-----------|
| 11.2 Errata | .24 |
| 12. Document Revision History | 25 |
| Table of Contents | 26 |

Silicon Labs

Simplicity Studio™4

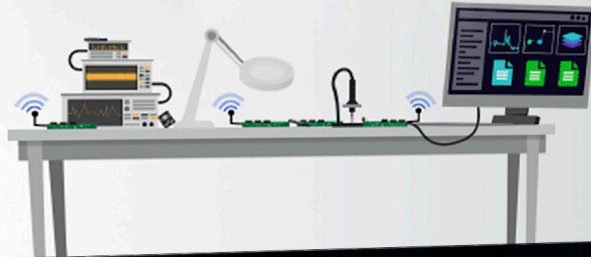

Simplicity Studio

One-click access to MCU and wireless tools, documentation, software, source code libraries & more. Available for Windows, Mac and Linux!



IoT Portfolio
www.silabs.com/IoT



SW/HW
www.silabs.com/simplicity



Quality
www.silabs.com/quality



Support and Community
community.silabs.com

Disclaimer

Silicon Labs intends to provide customers with the latest, accurate, and in-depth documentation of all peripherals and modules available for system and software implementers using or intending to use the Silicon Labs products. Characterization data, available modules and peripherals, memory sizes and memory addresses refer to each specific device, and "Typical" parameters provided can and do vary in different applications. Application examples described herein are for illustrative purposes only. Silicon Labs reserves the right to make changes without further notice and limitation to product information, specifications, and descriptions herein, and does not give warranties as to the accuracy or completeness of the included information. Silicon Labs shall have no liability for the consequences of use of the information supplied herein. This document does not imply or express copyright licenses granted hereunder to design or fabricate any integrated circuits. The products are not designed or authorized to be used within any Life Support System without the specific written consent of Silicon Labs. A "Life Support System" is any product or system intended to support or sustain life and/or health, which, if it fails, can be reasonably expected to result in significant personal injury or death. Silicon Labs products are not designed or authorized for military applications. Silicon Labs products shall under no circumstances be used in weapons of mass destruction including (but not limited to) nuclear, biological or chemical weapons, or missiles capable of delivering such weapons.

Trademark Information

Silicon Laboratories Inc.®, Silicon Laboratories®, Silicon Labs®, SiLabs® and the Silicon Labs logo®, Bluegiga®, Bluegiga Logo®, Clockbuilder®, CMEMS®, DSPLL®, EFM®, EFM32®, EFR®, Ember®, Energy Micro, Energy Micro logo and combinations thereof, "the world's most energy friendly microcontrollers", Ember®, EZLink®, EZRadio®, EZRadioPRO®, Gecko®, ISOModem®, Precision32®, ProSLIC®, Simplicity Studio®, SiPHY®, Telegesis, the Telegesis Logo®, USBXpress® and others are trademarks or registered trademarks of Silicon Labs. ARM, CORTEX, Cortex-M3 and THUMB are trademarks or registered trademarks of ARM Holdings. Keil is a registered trademark of ARM Limited. All other products or brand names mentioned herein are trademarks of their respective holders.



SILICON LABS

Silicon Laboratories Inc.
400 West Cesar Chavez
Austin, TX 78701
USA

<http://www.silabs.com>



Стандарт Электрон Связь

Мы молодая и активно развивающаяся компания в области поставок электронных компонентов. Мы поставляем электронные компоненты отечественного и импортного производства напрямую от производителей и с крупнейших складов мира.

Благодаря сотрудничеству с мировыми поставщиками мы осуществляем комплексные и плановые поставки широчайшего спектра электронных компонентов.

Собственная эффективная логистика и склад в обеспечивает надежную поставку продукции в точно указанные сроки по всей России.

Мы осуществляем техническую поддержку нашим клиентам и предпродажную проверку качества продукции. На все поставляемые продукты мы предоставляем гарантию .

Осуществляем поставки продукции под контролем ВП МО РФ на предприятия военно-промышленного комплекса России , а также работаем в рамках 275 ФЗ с открытием отдельных счетов в уполномоченном банке. Система менеджмента качества компании соответствует требованиям ГОСТ ISO 9001.

Минимальные сроки поставки, гибкие цены, неограниченный ассортимент и индивидуальный подход к клиентам являются основой для выстраивания долгосрочного и эффективного сотрудничества с предприятиями радиоэлектронной промышленности, предприятиями ВПК и научно-исследовательскими институтами России.

С нами вы становитесь еще успешнее!

Наши контакты:

Телефон: +7 812 627 14 35

Электронная почта: sales@st-electron.ru

Адрес: 198099, Санкт-Петербург,
Промышленная ул, дом № 19, литера Н,
помещение 100-Н Офис 331